



Stormwater Management Report and Servicing Brief

Proposed Halo Car Wash
3555 Borrisokane Rd
Barrhaven, Ontario
REV 04

Prepared for:

Halo Car Wash Inc.
18 Adelaide Street
Maxville, ON
K0C 1T0

Attention: Mr. Jordan Lupovici

LRL File No.: 210691

REV 04: May 9, 2023
REV 03: March 31, 2023
REV 02: Feb 22, 2023
REV 01: October 21, 2022
April 22, 2022

TABLE OF CONTENTS

1	INTRODUCTION AND SITE DESCRIPTION	1
2	EXISTING SITE AND DRAINAGE DESCRIPTION	2
3	SCOPE OF WORK	2
4	REGULATORY APPROVALS	3
5	WATER SUPPLY AND FIRE PROTECTION	3
5.1	Existing Water Supply Services.....	3
5.2	Water Supply Servicing Design	3
6	SANITARY SERVICE	6
6.1	Existing Sanitary Sewer Services.....	6
6.2	Sanitary Sewer Servicing Design	6
7	STORMWATER MANAGEMENT	7
7.1	Existing Stormwater Infrastructure	7
7.2	Design Criteria	7
7.2.1	Water Quality.....	7
7.2.2	Water Quantity	8
7.3	Method of Analysis	8
7.4	Proposed Stormwater Quantity Controls.....	8
8	EROSION AND SEDIMENT CONTROL	10
9	CONCLUSION	10
10	REPORT CONDITIONS AND LIMITATIONS	11



APPENDICES

- Appendix A Pre-consultation / Correspondence
- Appendix B Water Supply Calculations
- Appendix C Wastewater Calculations
- Appendix D Stormwater Management Calculations
- Appendix E Civil Engineering Drawings
- Appendix F Survey, As-Built Drawings

LIST OF TABLES

Table 1: City of Ottawa Water Servicing Design Parameters.....	4
Table 2: Summary of Boundary Conditions	5
Table 3: City of Ottawa Wastewater Design Parameters.....	6
Table 4: Drainage Areas and Runoff Coefficients.....	9
Table 5: Summary of Proposed Development Stormwater Release Rates.....	9

LIST OF FIGURES

Figure 1 – Aerial View of Proposed Development	1
--	---



1 INTRODUCTION AND SITE DESCRIPTION

LRL Associates Ltd. was retained by Halo Car Wash Inc. to complete a Stormwater Management Analysis and Servicing Brief for the construction of a car-wash development located at 3555 Borriskane Rd, Barrhaven, Ontario. The property is legally described as Part of Lot 11, Concession 3 (Rideau Front), geographic Township of Nepean and Zoning IL – Light Industrial. The location of the proposed development can be viewed in Figure 1.



Figure 1: Aerial View of Proposed Development

The development proposes construction of a Halo Tunnel Car Wash (± 513 sqm). The site will be accessible from a 7.5 m wide entrance located off Flagstaff Drive. This entrance will be a shared ROW once the future development to the south is developed. For additional details of the proposed development, refer to Site Plan C201 included in Appendix E.

This report has been prepared in consideration of the terms and conditions noted above and with the civil drawings prepared for the proposed new development. Should there be any changes in the design features, which may relate to the stormwater management and servicing considerations, LRL Associates Ltd. should be advised to review the report recommendations.

2 EXISTING SITE AND DRAINAGE DESCRIPTION

The subject site measures approximately 0.534 ha and is currently undeveloped, consisting of grassed area and treed area. Elevations of existing site range between 93.01 near the northeast corner to 92.23 at the southwest corner of the site.

Sewer and watermain locations were adopted from the current subdivision design produced by DSEL Engineering. It indicates the following infrastructures located within the adjacent right-of-way:

Flagstaff Drive

- 200 mm diameter PVC watermain stub
- 200 mm diameter PVC sanitary sewer

Borrisokane Rd

- Roadside ditch

The design intentions are to continue the water and sanitary services that were provided through this subject property and stub them past the proposed curb for future development to the south. This development will be connected to those services, and the storm outlet will be directed to the roadside ditch along Borrisokane Rd.

3 SCOPE OF WORK

As per applicable guidelines, the scope of work includes the following:

Stormwater management

- Calculate the allowable stormwater release rate.
- Calculate the anticipated post-development stormwater release rates.
- Demonstrate how the target quantity control objectives will be achieved.
- Demonstrate how the target quality control objectives will be achieved.

Water services

- Calculate the expected water supply demand at average and peak conditions.
- Calculate the required fire flow as per the Fire Underwriters Survey (FUS) method.
- Confirm the adequacy of water supply and pressure during peak flow and fire flow.
- Describe the proposed water distribution network and connection to the existing system.



Sanitary services

- Describe the existing sanitary sewers available to receive wastewater from the proposed development.
- Calculate peak flow rates from the proposed development.
- Describe the proposed sanitary sewer system.

4 REGULATORY APPROVALS

An MECP Environmental Compliance Approval (ECA) is expected to be required for installation of the proposed storm and sanitary sewers within the site. A Permit to Take Water is not anticipated to be required for pumping requirements for sewer installation. The Rideau Valley Conservation Authority (RVCA) will need to be consulted in order to obtain municipal approval for site development. No other approval requirements from other regulatory agencies are anticipated.

5 WATER SUPPLY AND FIRE PROTECTION

5.1 Existing Water Supply Services

The subject property is located to the south of a proposed 300 mm dia. watermain along Flagstaff Drive. A 200 mm dia. water service stub is available near the northeast corner of the property for service connection.

5.2 Water Supply Servicing Design

The subject property is proposed to be serviced via a 100 mm dia. water servicing to be connected to the 200 mm dia. watermain which will be extended from the existing stub located within Flagstaff Drive at the northeast corner of the site. Since the average water demand exceeds 50 m³/day, a looped system separated by an isolation valve is proposed. For servicing layout, refer to Site Servicing Plan C401 (Appendix E).

Table 1 summarizes the City of Ottawa Design Guidelines design parameters employed in the preparation of the water demand estimate.



Table 1: City of Ottawa Water Servicing Design Parameters

Design Parameters	Value
Average Day Demand - Commercial	28,000 L/gross ha/day
Average Day Demand - Light Industrial	35,000 L/gross ha/day
Maximum Day Demand-Commercial/Industrial	1.5 × Average Day Demand
Maximum Hour Demand-Commercial/Industrial	1.8 × Maximum Day Demand
Minimum Depth of Cover	2.4 m from top of watermain to finished grade
Desired operating pressure during Maximum Day Flow	345 kPa (50 psi) to 552 kPa (80 psi)
Minimum allowable pressure during Peak Hour Flow	275 kPa (40 psi)
Minimum allowable pressure during Fire Flow Conditions	140 kPa (20 psi)

Below is a summary of anticipated water demands calculated by using the parameters mentioned in Table 1 together with anticipated car wash demand & demands from south parcels (Part 3 & Part 5) as per the Servicing Brief prepared by Pearson Engineering, dated Nov 17, 2022. Refer to Appendix B for calculation details.

- Average Day Demand = 1.85 L/s
- Maximum Day Demand = 3.14 L/s
- Peak Hour Demand = 7.74 L/s

The City of Ottawa provided boundary conditions associated with the estimated water demand (correspondence included in Appendix B). Table 2 below summarizes the boundary conditions for the proposed development.



Table 2: Summary of Boundary Conditions

Design Parameter	Anticipated Demand (L/s)	Boundary Conditions @ Flagstaff Dr.	
		*Existing Conditions (m H2O / psi)	*Future Conditions (SUC Pressure Zone) (m H2O / psi)
Average Daily Demand	1.85	156.4/89.4	146.7/75.6
Peak Hour	7.74	142.4/69.5	142.7/68.9
Max Day + Fire Flow	3.14 + 65	137.4/62.4	142.3/69.3

**Ground elevation assumed at 93.5 m for Connection 1 @ Flagstaff Dr.*

Hydraulic analysis of the proposed watermain & servicing network was performed using EPANET (Version 2.2). Below is the summary of calculated residual pressures above finished grade at the service entry node (J-7) at Halo Car Wash Building.

Existing Conditions (Pressure Zone 3SW)

- Scenario 1: Average Day = 89.24 psi
- Scenario 2: Peak Hour = 69.05 psi
- Scenario 3: Max Day + Fire Flow = 62.21 psi

Future Conditions (Pressure Zone SUC)

- Scenario 4: Average Day = 75.45 psi
- Scenario 5: Peak Hour = 69.48 psi
- Scenario 6: Max Day + Fire Flow = 69.17 psi

The available pressure mentioned above corroborates with the City design criteria mentioned in Table 1, except for the average day demand (Scenario 1) when the maximum pressure exceeds 80 psi. Therefore, a pressure reducing valve (PRV) is needed as the residual pressure is not to exceed 80 psi. For modeling results, see Appendix B.

The estimated fire flow for the proposed buildings was determined in accordance with Fire Underwriters Survey (FUS) using the formula:

$$F = 220C\sqrt{A}$$

where,

F = The required fire flow (L/min)

C = Coefficient related to the type of construction



A = The total floor area (m²)

The estimated fire flow demand is calculated 3900 L/min, see Appendix B for calculation details. Two (2) fire hydrants in proximity to the site along Flagstaff Dr is expected to provide required fire flow for the subject site. Refer to Servicing Plan C401 for the location of available fire hydrants.

6 SANITARY SERVICE

6.1 Existing Sanitary Sewer Services

There is an existing 200 mm dia. sanitary sewer service stub extending to the property line from Flagstaff Dr. at the northeast corner of the subject site.

6.2 Sanitary Sewer Servicing Design

As previously stated, the sanitary sewer will be extended along the south extent of the property and stubbed at the proposed curb. The proposed development will be serviced via 150 mm dia. sanitary sewers which will be connected to the proposed 200mm dia. sanitary sewer extending to the subject site. Refer to LRL drawing C401 for the proposed sanitary servicing layout. Table 3 summarizes the City of Ottawa Design Guidelines design parameters used in the estimation of wastewater flow.

Table 3: City of Ottawa Wastewater Design Parameters

Design Parameters	Value
Commercial Average Flow	28,000 L/gross ha/day
Average Light Industrial Flow	35,000 L/gross ha/day
Commercial Peak Factor	1.5
Industrial Peak Factor	Appendix 4-B (City Guidelines-Sewer)
Infiltration Allowance (Dry Weather)	0.05 L/s/gross ha
Infiltration Allowance (Wet Weather)	0.28 L/s/gross ha
Total Infiltration Allowance	0.33 L/s/gross ha



Based on these parameters, City of Ottawa's Appendix 4-A (Daily Sewage Flow for Various Types of Establishments), and the car wash information as per Halo Car Wash, the anticipated post-development peak design wastewater flow for the subject site is calculated 6.32 L/s. Anticipated flow from future development is also included sanitary sewer design sheet, refer to Appendix C for calculation details.

7 STORMWATER MANAGEMENT

7.1 Existing Stormwater Infrastructure

There is an existing roadside ditch along Borrisokane Rd. at the west extent of the site.

In pre-development conditions, the stormwater runoff would flow uncontrolled overland to the existing ditch. Refer to Appendix D for pre- and post-development watershed information.

7.2 Design Criteria

The stormwater management criteria for this development is based on pre-consultation meeting with the City of Ottawa officials, the City of Ottawa Sewer Design Guidelines, 2012 (City standards), as well as the Ministry of the Environment's Stormwater Management, Planning and Design Manual, 2003.

7.2.1 Water Quality

Based on site plan pre-consultation meeting note and correspondence with Rideau Valley Conservation Authority (RVCA), it was advised to achieve enhanced water quality protection (80% TSS removal) either through on-site or downstream infrastructure prior to discharging stormwater to a natural watercourse.

To address water quality objective, a Jellyfish Filter model JF4-2-1 is proposed downstream of CBMH10 which will exceeds the required 80% TSS removal. As per manufacturers, JF4-2-1 will have the following capacities.

- Maximum Treatment Flow Rate: 12.6 L/s
- Filter Sediment Capacity: 142 kg
- Maximum Sump Maintenance Sediment Capacity: 356 L
- Maximum Hydrocarbon Storage Capacity: 379 L
- Total Storage Volume: 2,313 L



Refer to Appendix D for additional details on proposed treatment unit and Servicing Plan C401 (Appendix E) for its location.

7.2.2 Water Quantity

The allowable release rate for the subject site has been calculated to 5-yr pre-development level and was determined 30.95 L/s. Post-development storm events up to and including 100-yr storm will be controlled to 5-yr pre-development level. For calculations, refer to STM design calculation sheets in Appendix D.

7.3 Method of Analysis

The modified Rational Method has been used to calculate the peak flow rate from the proposed site and to quantify the storage required for quantity control for the proposed development.

$$Q = 2.78CIA$$

Where,

Q = Flow (L/s)

C = Runoff Coefficient

I = Rainfall Intensity (mm/hr), determined from the City of Ottawa IDF curves

A = Area (ha)

Refer to Appendix D for runoff and storage calculations.

7.4 Proposed Stormwater Quantity Controls

The proposed stormwater management quantity control for this development will be accomplished using an Inlet Control Device (ICD). Ponding required as a result of quantity control will be accomplished through surface storage in the parking lot.

A network of storm sewers is proposed to service the site which will outlet to the existing ditch along Borrisokane Rd and eventually to the existing 800mm dia. culvert crossing Borrisokane Rd. Refer to Site Servicing Plan C401 and Appendix D for calculation details.

The existing site is delineated by catchments EWS-01 which currently drains uncontrolled towards the west and outlet to the existing ditch. Refer to Pre-development Watershed Plan C701



(Appendix E). The site has been analyzed and post-development watersheds have been allocated. A few watersheds WS-09 and WS-10 consisting of grass area will flow un-controlled off the site. For additional details, refer to Post-development Watershed Plan C702 (Appendix E). Overland flow in Halo Car Wash area within watersheds WS-01A, WS-01B, WS-02, WS-03, WS-04, WS-05, WS-06, WS-07 & WS-08 will be captured by a several CB/CBMHs. An ICD, Hydrovex Vortex Flow Regulator 125VHV-2 (or approved equivalent), is proposed at CBMH10 to restrict the collected runoff and control the release rate at 24.86 L/s (H=2.04 m). For additional details on select ICD, refer to Appendix D. Table 4 summarizes post-development drainage areas. Additional details and calculations can be found in Appendix D.

Table 4: Drainage Areas and Runoff Coefficients

Watersheds	Area (ha)	Weighted Runoff Coefficient (C)
WS-01A (controlled)	0.045	0.29
WS-01B (controlled)	0.017	0.79
WS-02 (controlled)	0.049	0.90
WS-03 (controlled)	0.030	0.87
WS-04 (controlled)	0.101	0.58
WS-05 (controlled)	0.053	0.90
WS-06 (controlled)	0.123	0.87
WS-07 (controlled)	0.039	0.76
WS-08 (controlled)	0.027	0.20
WS-09 (uncontrolled)	0.029	0.20
WS-10 (uncontrolled)	0.020	0.20
Total	0.534	0.67

Table 5 summarizes the release rates, storage volume required and available storage in the proposed site. Refer to Appendix D for runoff and storage calculation details.

Table 5: Summary of Stormwater Release Rates & Storage

Watersheds	Area (ha)	Release Rate (L/s)			Storage Required (m ³)			Total Storage Provided (m ³)
		100-yr	5-yr	2-yr	100-yr	5-yr	2-yr	
Controlled (WS-01 to WS-08)	0.485	24.86	24.86	24.86	199.45	71.96	46.81	211.16
Uncontrolled (WS-09 to WS-10)	0.049	6.09	2.84	2.10	N/A	N/A	N/A	N/A
Total	0.534	30.95	27.70	26.96	199.45	71.96	46.81	211.16

The runoff exceeding the allowable release rate will be stored on-site via surficial ponding and underground storage. For 100-yr storm event, it is calculated that a total of 199.45 m³ of storage



will be required to attenuate flows to the allowable release rate of 24.86 L/s (controlled release). The total storage provided is 211.16 m³, thus exceeds the required storage. The required storage for 2-yr storm will be accommodated underground in oversized pipe and CB/CBMH/MH structures which will provide a total storage of 49.18 m³. The storm events greater than 100-yr will flow overland towards Borrisokane roadside ditch from the spillover point (depressed curve) provided at 100-yr HWL elevation of 93.20, refer to Grading Plan (C301). The maximum ponding elevation and depths can be found on Stormwater Management Plan C601 (Appendix E).

8 EROSION AND SEDIMENT CONTROL

During construction, erosion and sediment controls will be provided primarily via a sediment control fence to be erected along the perimeter of the site where runoff has the potential of leaving the site. Inlet sediment control devices are also to be provided in any catch basin and/or manholes in and around the site that may be impacted by the site construction. Construction and maintenance requirements for erosion and sediment controls are to comply with Ontario Provincial Standard Specification OPSS 577. Refer to Erosion and Sediment Control Plan C101 for additional details.

9 CONCLUSION

This Stormwater Management and Servicing Report for the proposed development at 3555 Borrisokane Rd presents the rationale and details for the servicing requirements for the subject property. In accordance with the report objectives, the servicing requirements for the development are summarized below.

Water Service

- The anticipated maximum hour demand of the proposed development is 6.72 L/s.
- The maximum required fire flow is 65.00 L/, calculated using the FUS method.
- The fire hydrants along Flagstaff Dr will service the proposed development.
- The proposed development will be serviced with a new 100 mm dia. watermain to be connected to the proposed dual 200 mm dia. watermain to be extended from Flagstaff Dr.
- Boundary Conditions received from the City of Ottawa show that adequate pressure is available to service the proposed development.



Sanitary Service

- The anticipated sanitary flow from the proposed development is 6.32 L/s.
- The proposed development will be serviced by a network of 150 mm dia. sanitary sewers which will connect to the proposed 200 mm dia. SAN sewer to be extended from the existing stub.

Stormwater Management

- Stormwater quality control requirements of 80% TSS removal will be met using stormwater treatment unit (Jellyfish Filter JF4-2-1).
- The storm water release rates from the proposed development will meet contemplated allowable release rate of 30.95 L/s (24.86 L/s controlled and 6.09 L/s uncontrolled).
- Stormwater quantity control objectives will be met using an Inlet Control Device (ICD) to restrict flow and on-site stormwater surface storage and underground storage.

10 REPORT CONDITIONS AND LIMITATIONS

The report conclusions are applicable only to this specific project described in the preceding pages. Any changes, modifications or additions will require a subsequent review by LRL Associates Ltd. to ensure the compatibility with the recommendations contained in this document.

If you have any questions or comments, please contact the undersigned.

Prepared by:

LRL Associates Ltd.

Maxime Longtin

Maxime Longtin
Civil Engineering Technologist



Mohan Basnet, P.Eng.
Civil Engineer



APPENDIX A

Pre-consultation / Correspondance

3555 Borrisokane Road
Meeting Summary Notes
Sept 23, 2021. Online Teams Meeting

Attendees:

- Jonah Bonn (Applicant, First Bay Properties Inc.)
- Bill Holzman (Applicant, Holzman Consultants)
- Philippe Paquette (LRL Associates)
- Peter MacEwen (MacEwen)
- Brad Moore (MacEwen)
- Greg Pedersen (Halowash)
- Jordan Lupovici (Halowash)
- Katie Morphet (File Lead, Panner, City of Ottawa)
- Jeff Shillington (Project Manager, City of Ottawa)
- Neeti Paudel (Transportation Project Manager, City of Ottawa)
- Sami Rehman (Environmental, City of Ottawa)
- Jeannette Krabicka (Parks, City of Ottawa)

Not in Attendance:

- Mark Richardson (Forestry, City of Ottawa)
- RVCA

Issue of Discussion:

- Site Plan Control for a new 1-storey 480 sq. m drive-through carwash with 3 queuing lanes for 18 cars and 21 parking spaces (18 of which are vacuum accessible).
- Development to be located on northern most 1.32 acres of total vacant property.

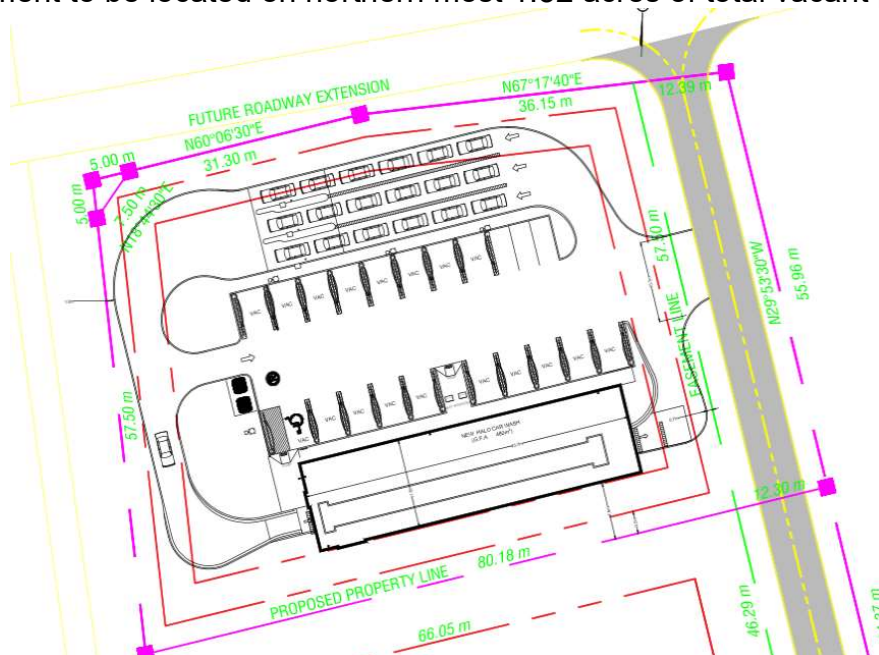

1. Official Plan - designated "General Urban Area".

Car wash a permitted use

Barrhaven South CDP – property identified as institutional

2. Zoning Information

Zoned IL [304]

Urban Exception 304 permits place of worship as an additional use.

IL Zone permits Drive-Through Facility and Car wash uses

Zoning interpretation has confirmed that Section 203 (2)(c) limits the Car wash use to 300 sq. m.

Floodplain overlay on a portion of the site – RVCA has confirmed that this floodplain area has been removed from their mapping. It will still need to be removed from the City's mapping.

Within the 400 m MTO Permit Control Area

3. Infrastructure/Servicing – Jeff Shillington

- Servicing for the subdivision is currently being designed by DSEL for Mattamy. To coordinate service locations please contact Jen Ailey at DSEL (email: jailey@dssel.ca, cell no. 613-222-6476)
- The current design has not yet been approved, however a 2nd submission of the detailed design is currently under review. There were no significant concerns with any of the servicing proposed for this area.
- The current design shows the following:
 - 300 mm dia. sanitary sewer along Flagstaff with a 200 mm service and control MH proposed just inside the property in the northeast corner.
 - 300 mm watermain along Flagstaff with a 200 mm service and valve on the property line in the northeast corner of the property.
 - No storm sewer is proposed along Flagstaff. Stormwater could be outlet into the ditch on Borrisokane Road. A C=0.80 for the 5 year event should be used for the design. As per RVCA requirements the stormwater must maintain enhanced water quality protection either through on-site or down stream infrastructure prior to outletting to the Jock River.

- A MECP ECA is likely required for the stormwater outlet to the Borrisokane ditch.
- As discussed at the meeting a shared servicing corridor along the private road would be possible to service the neighboring site to the south. A joint use maintenance agreement and MECP ECA for the shared sanitary sewer would be required.

4. Initial Planning Comments – Katie Morphet

- Please add table to submitted site plan to identify all required zone and applicable general provisions and that they are being met.
- I have been able to confirm that Section 203 (2)(c) does limit the proposed car wash use to 300 sq.m. If you wish to move forward with a footprint of this size a minor variance would need to be approved prior to the Site Plan being finalized and approved. I understand that the minor variance process is severely backed up due to covid so I would inquire with the Committee timing for the next available meeting.
- The floodplain overlay will need to be removed from the property prior to approval of a Site Plan.

The flood plain can be dealt with multiple ways.

1. You can undertake a site-specific ZBA;
 2. If the timing works for both the applicant and the zoning group the City can add it to the omnibus report. The next omnibus report is expected in Q1 of 2022. This means it could go forward at the end of April 2022; or
 3. It will be removed when the City undertakes flood plain mapping updates. The floodplain mapping for this area is expected to be updated by the end of the year but it is not guaranteed.
- A Survey Plan will be required to clarify property boundaries and lot ownership.
 - The Site Plan design drawings and agreement and will apply to entire lot if it is yet to be severed at the time of application.
 - The site is within 400m of the High 416 – MTO Permit control Area – please confirm with MTO whether you require a permit from them.

5. Parks – Jeanette Krabicka

Please see the attached comments.

6. Trees - Mark Richardson

- 1) if there are trees >10cm in diameter on site a tree removal permit will required and a TCR will need to be submitted with their application
- 2) they will need to contact mark.richardson@ottawa.ca for information on the permitting and TCR process.

7. Environment – Sami Rehman

The subject property is located adjacent to an Urban Natural Feature (UNF) called Cambrian Woods North and the proposal requires an Environmental Impact Statement (EIS) as outlined in OP section 3.2.3 and 4.7.8. As such, the EIS will need to address:

- potential impacts from the development on the UNF
- potential impacts from the development on the adjacent watercourse
- significant habitat for threatened or endangered species
- review and draw recommendations from the Jock River Reach 1 Subwatershed Plan
- review and draw recommendations from the Protocol for Wildlife Protection during Construction

Further details on the EIS requirements can be found in OP Section 4.7.8 or the EIS guidelines:

https://documents.ottawa.ca/sites/documents/files/documents/eis_guidelines2015_en.pdf

City staff will be looking to ensure that the proposal's design includes buffering along the adjacent watercourse.

Staff are also recommending landscaping and design elements that will reduce energy and water consumption, as outlined in OP Section 4.9.

Given the subject property's proximity to the UNF, the adjacent watercourse and the Jock River, staff will be anticipating using only locally appropriate native species in their landscape plan.

I recommend contacting the Trail Road Waste Facility to identify their comments or advice for this proposed development because the subject property is within 500m of the facility.

I would also recommend consulting with the Rideau Valley Conservation Authority to determine if any permits or approvals are required under their regulations.

While not explicitly discussed in this meeting, a severance will trigger the requirement for an EIS and the advice provided above would be applicable to that EIS and severance application.

8. Conservation Authority – Eric Lalande (RVCA)

For the floodplain, mapping below shows that the floodplain does not extend onto the property. This was confirmed and updated on our end earlier this year, and mapping at the City should be updated through an omnibus zoning amendment.

As for SWM and TSS removal, you are required to maintain enhanced water quality protection either through on-site or down stream infrastructure prior to any outlet to a natural watercourse. Note that setbacks and stormwater should take into consideration the realigned channel adjacent to your site (along the easterly property boundary).

Given the use, I would also suggest you contact the City's HydroG related to any groundwater constraints given the use.

9. Transportation – Neeti Paudel

Follow Traffic Impact Assessment Guidelines

- Complete the screening form as soon as possible and submit it to the Neeti Paudel at neeti.paudel@ottawa.ca for review. Please include the **site generated trips** for the trip generation trigger. Once reviewed, and if, the triggers are met, proceed to Step 2.
- **Applicant advised that their application will not be deemed complete until the submission of the draft step 1-4, including the functional draft RMA package (if applicable) and/or monitoring report (if applicable). Collaboration and communication between development proponents and City staff are required at the end of every step in the TIA process**
- Request base mapping asap if RMA is required. Contact Engineering Services (<https://ottawa.ca/en/city-hall/planning-and-development/engineering-services>)
- Noise Impact Studies required for the following:
 - Stationary (if, within 100m of noise sensitive land use).
- Ensure clear throat length requirements as per TAC are met at the accesses.

- On site plan:
 - Show all details of the roads abutting the site up to and including the opposite curb; include such items as pavement markings, accesses and/or sidewalks.
 - Turning templates will be required for all accesses showing the largest vehicle to access the site; required for internal movements and at all access (entering and exiting and going in both directions).
 - Show all curb radii measurements; ensure that all curb radii are reduced as much as possible

- As the proposed site is for general public use, AODA legislation applies. Consider using the City's Accessibility Design Standards.

- Number of accessible parking spaces should meet the requirements from Table 3 of the City's accessible Design Standards.

- Site triangles at the following locations on the final plan will be required:
 - Local Road to Local Road: 3 metre x 3 metres
 - Local Road to Collector Road: 5 metre x 5 metres
 - Collector Road to Collector Road: 5 metre x 5 metres
 - Collector Road to Arterial Road: 5 metre x 5 metres

10. General Information

- a. Ensure that all plans and studies are prepared as per City guidelines – as available online...
<https://ottawa.ca/en/city-hall/planning-and-development/information-developers/development-application-review-process/development-application-submission/guide-preparing-studies-and-plans>

Mohan Basnet

From: Eric Lalande <eric.lalande@rvca.ca>
Sent: September 24, 2021 10:42 AM
To: Philippe Paquette; Jamie Batchelor
Cc: katie.morphet@ottawa.ca; Brad Moore; Jordan Lupovici; Jonah Bonn
Subject: RE: Future Halo carwash Borrisokane Rd. Barrhaven ON. (LRL#210691)

Hi Philippe,

As for the floodplain, mapping below shows that the floodplain does not extend onto the property. This was confirmed and updated on our end earlier this year, and mapping at the City should be updated through an omnibus zoning amendment.

As for SWM and TSS removal, you are required to maintain enhanced water quality protection either through on-site or down stream infrastructure prior to any outlet to a natural watercourse. Note that setbacks and stormwater should take into consideration the realigned channel adjacent to your site (along the easterly property boundary).

Given the use, I would also suggest you contact the City's HydroG related to any groundwater constraints given the use.

Cheers,



Eric Lalande, MCIP, RPP
Planner, RVCA
613-692-3571 x1137

From: Philippe Paquette <ppaquette@lrl.ca>
Sent: Thursday, September 23, 2021 4:25 PM

To: Jamie Batchelor <jamie.batchelor@rvca.ca>; Eric Lalande <eric.lalande@rvca.ca>

Cc: katie.morphet@ottawa.ca; Brad Moore <b.moore@macewen.ca>; Jordan Lupovici <jlupovici@halowash.com>;
Jonah Bonn <jbonn@firstbay.ca>

Subject: Future Halo carwash Borrisokane Rd. Barrhaven ON. (LRL#210691)

Hi Jamie and Eric,

After pre-consulting with the City of Ottawa this morning regarding the above mentioned project, the City of Ottawa planner assigned to the file (Katie Morphet) gave me your contacts in order to discuss about the flood plain crossing this property, SWM and TSS removal criterion. To put you in context, our client wishes to purchase a piece of land located at the north end of the employment block of the Mattamy Homes Half Moon bay West Subdivision. Refer to the attached document for more info. Also attached is a preliminary plan of what they want to develop.

Let us know of your availability so we can book a meeting very soon.

Thanks for your time.

Philippe Paquette, C.E.T.

Certified Engineering Technologist



LRL Engineering

5430 Canotek Road
Ottawa, Ontario K1J 9G2

T (613) 842-3434 or (877) 632-5664 ext 209

C (613) 880-9793

F (613) 842-4338

E ppaquette@lrl.ca

W www.lrl.ca

Given the current COVID-19 situation, please be aware that LRL has implemented alternative working conditions for our team. Many of us have now transitioned to working from home; however, communication and workability remains one of our top priorities.

We will continue to be reachable by cell phone or by calling LRL at 613-842-3434 which will prompt you to enter the extension of the person you are trying to reach.

In addition, we will continue to have access to all e-mail correspondence and do our best to return all inquiries in a timely manner.



APPENDIX B
Water Supply Calculations



Water Service Calculations

LRL File No. : 210691

Project : Proposed Development - Halo Car Wash

Location : 3555 Borrisokane Rc

Date : February 7, 2023

Designed by : M. Basnet

Water Demand

Site area = ha (Part 1)

Average day demand = 35000 L / ha · day (based on Table 4.2 of Ottawa Design Guidelines-Water Distribution)
 = 18690 L / day
 = 0.22 L / s

Maximum daily peak factor = 1.5
Maximum daily demand = 0.32 L / s

Maximum hour peak factor = 1.8
Maximum hour demand = 0.58 L / s

Adjustment - Car Wash (as per Halo Car Wash Inc.)

Estimated vol. of water/car wash = L

Average day demand = 93151 L / day (assuming 200000 car wash/year)
1.08 L / s

Maximum daily demand = **1.97 L / s** (assuming 1000 car wash/day)

Maximum hour demand = **6.14 L / s** (assuming 130 car wash/hour)

Total Anticipated Water Demand (L/s)

	<u>Part 1</u>	<u>Part 3*</u>	<u>Part 5*</u>	<u>Total (L/s)</u>
Average day demand =	1.29	0.15	0.41	1.85
Maximum daily demand =	2.29	0.23	0.62	3.14
Maximum hour demand =	6.72	0.28	0.74	7.74

Note:*Water demands for south parcels (Part 3 and 5) were taken from Functional Servicing Brief, prepared by Pearson Engineering, dated Nov 17, 2022

Water Service Pipe Sizing (Part 1)

Q = VA Where: V = velocity
 A = area of water service pipe
 Q = water supply flow rate

By deriving the above formula with an assumed max. V=1.5 m/s

Minimum pipe diameter: $d = (4Q/\pi V)^{1/2}$
 $d = 0.076$ m
 $d = 76$ mm (minimum required size)

Proposed pipe diameter: mm



Fire Flow Calculations

LRL File No. 210691

Project: Proposed Development-Halo Car Wash

Location: 3535 Borrisokane Rd, Barrhaven, ON

Date: April 14, 2022

Method: Fire Underwriters Survey (FUS)

Prepared by: M. Basnet

Step	Task	Term	Options	Multiplier	Choose:	Value	Unit	Fire Flow	
Structural Framing Material									
1	Choose frame used for building	Coefficient C related to the type of construction	Wood Frame	1.5	Non-combustible Construction	0.8			
			Ordinary Construction	1.0					
			Non-combustible construction	0.8					
			Fire resistive construction <2 hrs	0.7					
			Fire resistive construction >2 hrs	0.6					
Floor Space Area (A)									
2			Total area			485	m ²		
3	Obtain fire flow before reductions	Required fire flow	$Fire\ Flow = 220 \times C \times A^{0.5}$				L/min	3,876	
Reductions or surcharge due to factors affecting burning									
4	Choose combustibility of contents	Occupancy hazard reduction or surcharge	Non-combustible	-25%	Combustible	0%	L/min	3,876	
			Limited combustible	-15%					
			Combustible	0%					
			Free burning	15%					
			Rapid burning	25%					
5	Choose reduction for sprinklers	Sprinkler reduction	Full automatic sprinklers	-30%	False	0%	L/min	3,876	
			Water supply is standard for both the system and fire department hose lines		-10%	False			0%
			Fully supervised system	-10%	False	0%			
6	Choose separation	Exposure distance between units	North side	>45m	0%	0%	L/min	3,876	
			East side	>45m	0%				
			South side	>45m	0%				
			West side	>45m	0%				
Net required fire flow									
7	Obtain fire flow, duration, and volume					Minimum required fire flow rate (rounded to nearest 100)	L/min	3,900	
						Minimum required fire flow rate	L/s	65.0	
						Required duration of fire flow	hr	1.5	

Mohan Basnet

From: Bramah, Bruce <bruce.bramah@ottawa.ca>
Sent: February 14, 2023 3:45 PM
To: Mohan Basnet
Cc: Kelly, Siobhan; Jordan Lupovici; Maxime Longtin
Subject: RE: Halo Car Wash_3535 Borrisokane Rd_ Revised Boundary Condition (LRL210691)

Hi Mohan,

Yes, the HGL would be the same for both connections.

Thanks,

--

Bruce Bramah, EIT

Project Manager

Planning, Real Estate and Economic Development Department / Direction générale de la planification, des biens immobiliers et du développement économique

Development Review - South Branch

City of Ottawa | Ville d'Ottawa

110 Laurier Avenue West Ottawa, ON | 110, avenue. Laurier Ouest. Ottawa (Ontario) K1P 1J1

613.580.2424 ext./poste 29686, Bruce.Bramah@ottawa.ca

From: Mohan Basnet <mbasnet@lrl.ca>
Sent: February 14, 2023 2:30 PM
To: Bramah, Bruce <bruce.bramah@ottawa.ca>
Cc: Kelly, Siobhan <siobhan.kelly@ottawa.ca>; Jordan Lupovici <jlupovici@halowash.com>; Maxime Longtin <mlongtin@lrl.ca>
Subject: RE: Halo Car Wash_3535 Borrisokane Rd_ Revised Boundary Condition (LRL210691)

CAUTION: This email originated from an External Sender. Please do not click links or open attachments unless you recognize the source.

ATTENTION : Ce courriel provient d'un expéditeur externe. Ne cliquez sur aucun lien et n'ouvrez pas de pièce jointe, excepté si vous connaissez l'expéditeur.

Thank you Bruce!

The BC received shows only 1 connection. However, actually there are 2 connections.

Is the BC received is applicable for both connections?

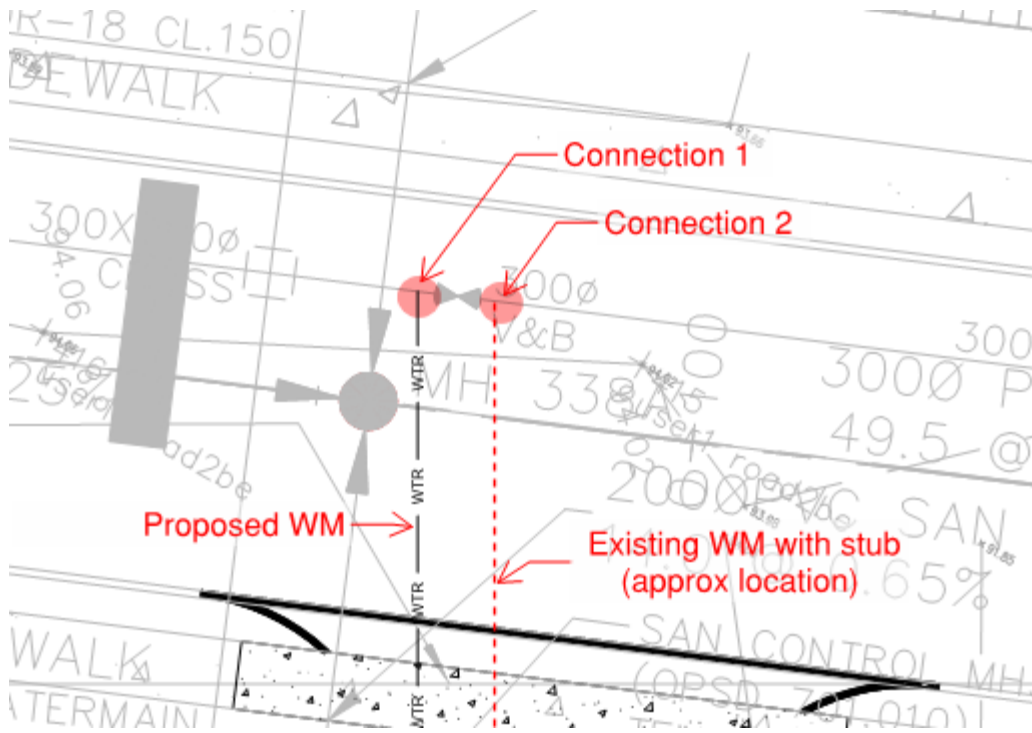

Thank you,

Mohan Basnet, P.Eng.

Civil Engineer

LRL Engineering

5430 Canotek Road
Ottawa, Ontario K1J 9G2

T (613) 842-3434

C (613) 229-6819

F (613) 842-4338

E mbasnet@lrl.ca

W www.lrl.ca

Given the current COVID-19 situation, please be aware that LRL has implemented alternative working conditions for our team. Many of us have now transitioned to working from home; however, communication and workability remains one of our top priorities.

We will continue to be reachable by cell phone or by calling LRL at 613-842-3434 which will prompt you to enter the extension of the person you are trying to reach.

In addition, we will continue to have access to all e-mail correspondence and do our best to return all inquiries in a timely manner.



From: Bramah, Bruce <bruce.bramah@ottawa.ca>

Sent: February 13, 2023 2:44 PM

To: Mohan Basnet <mbasnet@lrl.ca>

Cc: Kelly, Siobhan <siobhan.kelly@ottawa.ca>; Jordan Lupovici <jlupovici@halowash.com>;

Maxime Longtin <mlongtin@lrl.ca>

Subject: RE: Halo Car Wash_3535 Borrisokane Rd_ Revised Boundary Condition (LRL210691)

Good afternoon,

Please see the attached Boundary Conditions.

Thank you,

--

Bruce Bramah, EIT

Project Manager

Planning, Real Estate and Economic Development Department / Direction générale de la planification, des biens immobiliers et du développement économique

Development Review - South Branch

City of Ottawa | Ville d'Ottawa

110 Laurier Avenue West Ottawa, ON | 110, avenue. Laurier Ouest. Ottawa (Ontario) K1P 1J1

613.580.2424 ext./poste 29686, Bruce.Bramah@ottawa.ca

From: Mohan Basnet <mbasnet@lrl.ca>

Sent: February 08, 2023 10:36 AM

To: Bramah, Bruce <bruce.bramah@ottawa.ca>

Cc: Kelly, Siobhan <siobhan.kelly@ottawa.ca>; Jordan Lupovici <jlupovici@halowash.com>; Maxime Longtin <mlongtin@lrl.ca>

Subject: RE: Halo Car Wash_3535 Borrisokane Rd_ Revised Boundary Condition (LRL210691)

CAUTION: This email originated from an External Sender. Please do not click links or open attachments unless you recognize the source.

ATTENTION : Ce courriel provient d'un expéditeur externe. Ne cliquez sur aucun lien et n'ouvrez pas de pièce jointe, excepté si vous connaissez l'expéditeur.

Hi Bruce:

We are working to address SPA-2nd review comments for the proposed Halo Car Wash Development at 3535 Borrisokane Rd and require a boundary conditions at this site to proceed. Please use the following data to provide the revised boundary conditions.

- Service location/type: Dual connections at flagstaff drive (existing 200mm dia. stub + proposed 200mm dia. WM), please see attached draft servicing plan C401.
- Type of development: Proposed Car Wash building
- Average daily demand: 1.85 L/s (Part 1+Part 3+Part 5)
- Maximum daily demand: 3.14 L/s (Part 1+Part 3+Part 5)
- Peak hourly demand: 7.74 L/s (Part 1+Part 3+Part 5)
- FUS fire flow demand: 65.00 L/s (Part 1-Halo Car Wash)

Please note that water demands for the south parcels (Part 3 and Part 5) were taken from the Servicing Brief prepared by Pearson Engineering (Nov 17, 2022).

For your reference, I have also included copies of revised water demand calculations and FUS fire flow calculations along with this email.

Please let me know if you have any questions.

Thank you

Mohan Basnet, P.Eng.

Civil Engineer

LRL Engineering

5430 Canotek Road
Ottawa, Ontario K1J 9G2

T (613) 842-3434

C (613) 229-6819

F (613) 842-4338

E mbsnet@lrl.ca

W www.lrl.ca

Given the current COVID-19 situation, please be aware that LRL has implemented alternative working conditions for our team. Many of us have now transitioned to working from home; however, communication and workability remains one of our top priorities.

We will continue to be reachable by cell phone or by calling LRL at 613-842-3434 which will prompt you to enter the extension of the person you are trying to reach.

In addition, we will continue to have access to all e-mail correspondence and do our best to return all inquiries in a timely manner.



LRL

ENGINEERING | INGÉNIÉRIE

This e-mail originates from the City of Ottawa e-mail system. Any distribution, use or copying of this e-mail or the information it contains by other than the intended recipient(s) is unauthorized. Thank you.

Le présent courriel a été expédié par le système de courriels de la Ville d'Ottawa. Toute distribution, utilisation ou reproduction du courriel ou des renseignements qui s'y trouvent par une personne autre que son destinataire prévu est interdite. Je vous remercie de votre collaboration.

This e-mail originates from the City of Ottawa e-mail system. Any distribution, use or copying of this e-mail or the information it contains by other than the intended recipient(s) is unauthorized. Thank you.

Le présent courriel a été expédié par le système de courriels de la Ville d'Ottawa. Toute distribution, utilisation ou reproduction du courriel ou des renseignements qui s'y trouvent par une personne autre que son destinataire prévu est interdite. Je vous remercie de votre collaboration.

Boundary Conditions 3535 Borrisokane Rd (Halo Car Wash)

Provided Information

Scenario	Demand	
	L/min	L/s
Average Daily Demand	111	1.85
Maximum Daily Demand	188	3.14
Peak Hour	464	7.74
Fire Flow Demand #1	3,900	65.00

Location

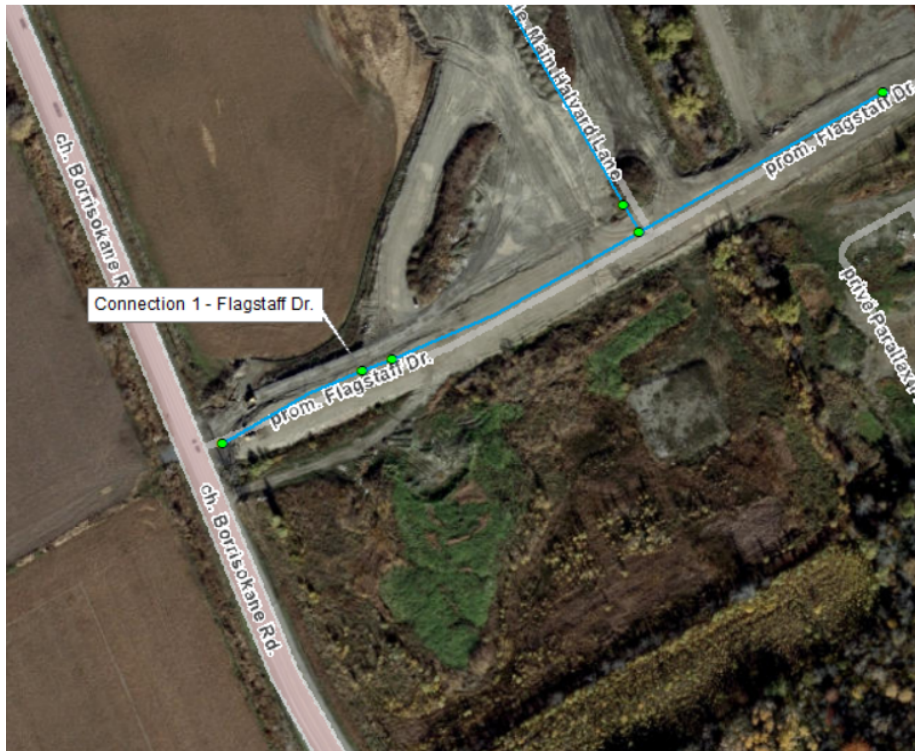

Results

Existing Conditions (Pressure Zone 3SW)

Connection 1 – Flagstaff Dr.

Demand Scenario	Head (m)	Pressure ¹ (psi)
Maximum HGL	156.4	89.4
Peak Hour	142.4	69.5
Max Day plus Fire Flow	137.4	62.4

¹ Ground Elevation = 93.5 m

Future Conditions (Pressure Zone SUC)

Connection 1 – Flagstaff Dr.

Demand Scenario	Head (m)	Pressure ¹ (psi)
Maximum HGL	146.7	75.6
Peak Hour	142.7	69.9
Max Day plus Fire Flow	142.3	69.3

¹ Ground Elevation = 93.5 m

Notes

1. As per the Ontario Building Code in areas that may be occupied, the static pressure at any fixture shall not exceed 552 kPa (80 psi.) Pressure control measures to be considered are as follows, in order of preference:
 - a. If possible, systems to be designed to residual pressures of 345 to 552 kPa (50 to 80 psi) in all occupied areas outside of the public right-of-way without special pressure control equipment.
 - b. Pressure reducing valves to be installed immediately downstream of the isolation valve in the home/ building, located downstream of the meter so it is owner maintained.

Disclaimer

The boundary condition information is based on current operation of the city water distribution system. The computer model simulation is based on the best information available at the time. The operation of the water distribution system can change on a regular basis, resulting in a variation in boundary conditions. The physical properties of watermains deteriorate over time, as such must be assumed in the absence of actual field test data. The variation in physical watermain properties can therefore alter the results of the computer model simulation. Fire Flow analysis is a reflection of available flow in the watermain; there may be additional restrictions that occur between the watermain and the hydrant that the model cannot take into account.

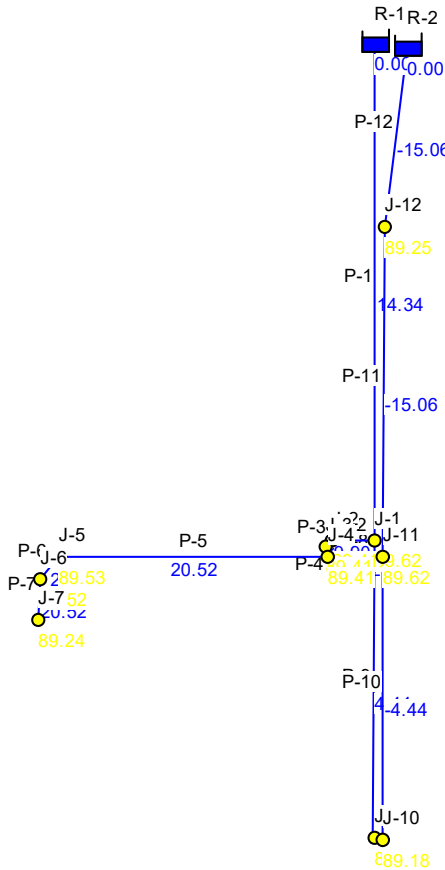
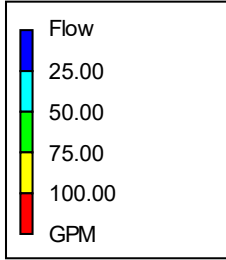
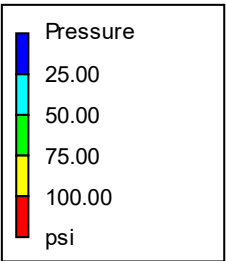

Scenario 1: Average Day

```

*****
*                               E P A N E T                               *
*                               Hydraulic and Water Quality                 *
*                               Analysis for Pipe Networks                   *
*                               Version 2.2                                 *
*****
    
```

Input File: 210691_Avg Day.net

Link - Node Table:

Link ID	Start Node	End Node	Length ft	Diameter in
P-1	R-1	J-1	150.88	8
P-3	J-2	J-3	2.95	4
P-4	J-3	J-4	2.95	4
P-5	J-4	J-5	80.03	4
P-6	J-5	J-6	9.84	4
P-7	J-6	J-7	13.12	4
P-8	J-4	J-11	15	4
P-9	J-1	J-9	88.56	8
P-10	J-10	J-11	85.28	8
P-11	J-11	J-12	101.68	8
P-12	J-12	R-2	54.45	8
P-2	J-1	J-2	12.5	4

Node Results:

Node ID	Demand GPM	Head ft	Pressure psi	Quality
J-1	0.00	512.99	89.62	0.00
J-2	0.00	512.99	89.41	0.00
J-3	0.00	512.99	89.41	0.00
J-4	0.00	512.99	89.41	0.00
J-5	0.00	512.96	89.53	0.00
J-6	0.00	512.96	89.52	0.00
J-7	20.52	512.96	89.24	0.00
J-9	4.44	512.99	89.18	0.00
J-10	4.44	512.99	89.18	0.00
J-11	0.00	512.99	89.62	0.00
J-12	0.00	512.99	89.25	0.00
R-1	-14.34	512.99	0.00	0.00 Reservoir
R-2	-15.06	512.99	0.00	0.00 Reservoir

Link Results:

Link ID	Flow GPM	Velocity fps	Unit Headloss ft/Kft	Status
P-1	14.34	0.09	0.01	Open
P-3	9.90	0.25	0.06	Open
P-4	9.90	0.25	0.08	Open
P-5	20.52	0.52	0.31	Open
P-6	20.52	0.52	0.30	Open
P-7	20.52	0.52	0.31	Open
P-8	-10.62	0.27	0.09	Open
P-9	4.44	0.03	0.00	Open
P-10	-4.44	0.03	0.00	Open
P-11	-15.06	0.10	0.01	Open
P-12	-15.06	0.10	0.01	Open
P-2	9.90	0.25	0.08	Open

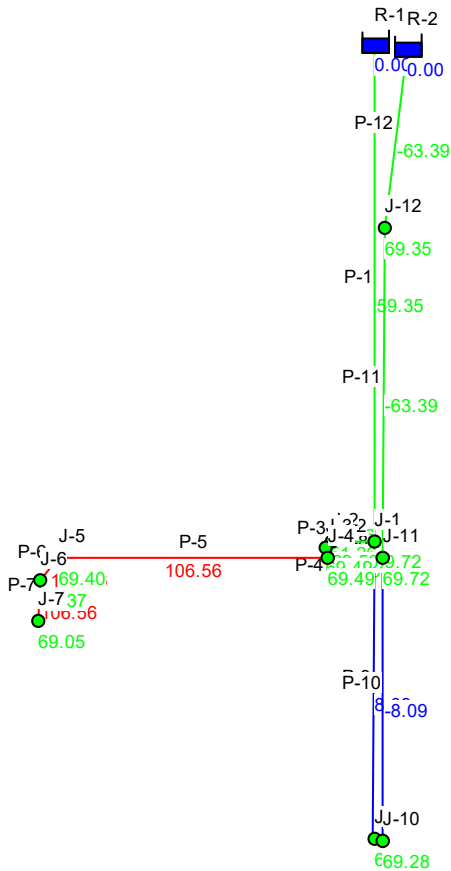
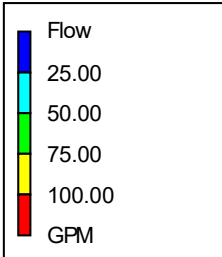
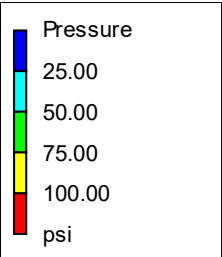

Scenario 2: Peak Hour

```
*****
*                               E P A N E T                               *
*                               Hydraulic and Water Quality                 *
*                               Analysis for Pipe Networks                   *
*                               Version 2.2                                 *
*****
```

Input File: 210691_Peak Hour.net

Link - Node Table:

Link ID	Start Node	End Node	Length ft	Diameter in
P-1	R-1	J-1	150.88	8
P-3	J-2	J-3	2.95	4
P-4	J-3	J-4	2.95	4
P-5	J-4	J-5	80.03	4
P-6	J-5	J-6	9.84	4
P-7	J-6	J-7	13.12	4
P-8	J-4	J-11	15	4
P-9	J-1	J-9	88.56	8
P-10	J-10	J-11	85.28	8
P-11	J-11	J-12	101.68	8
P-12	J-12	R-2	54.45	8
P-2	J-1	J-2	12.5	4

Node Results:

Node ID	Demand GPM	Head ft	Pressure psi	Quality
J-1	0.00	467.06	69.72	0.00
J-2	0.00	467.04	69.50	0.00
J-3	0.00	467.03	69.49	0.00
J-4	0.00	467.03	69.49	0.00
J-5	0.00	466.51	69.40	0.00
J-6	0.00	466.45	69.37	0.00
J-7	106.56	466.36	69.05	0.00
J-9	8.09	467.06	69.28	0.00
J-10	8.09	467.06	69.28	0.00
J-11	0.00	467.06	69.72	0.00
J-12	0.00	467.07	69.35	0.00
R-1	-59.35	467.07	0.00	0.00 Reservoir
R-2	-63.39	467.07	0.00	0.00 Reservoir

Link Results:

Link ID	Flow GPM	Velocity fps	Unit Headloss ft/Kft	Status
P-1	59.35	0.38	0.08	Open
P-3	51.26	1.31	1.68	Open
P-4	51.26	1.31	1.68	Open
P-5	106.56	2.72	6.49	Open
P-6	106.56	2.72	6.49	Open
P-7	106.56	2.72	6.48	Open
P-8	-55.30	1.41	1.92	Open
P-9	8.09	0.05	0.00	Open
P-10	-8.09	0.05	0.00	Open
P-11	-63.39	0.40	0.08	Open
P-12	-63.39	0.40	0.08	Open
P-2	51.26	1.31	1.67	Open

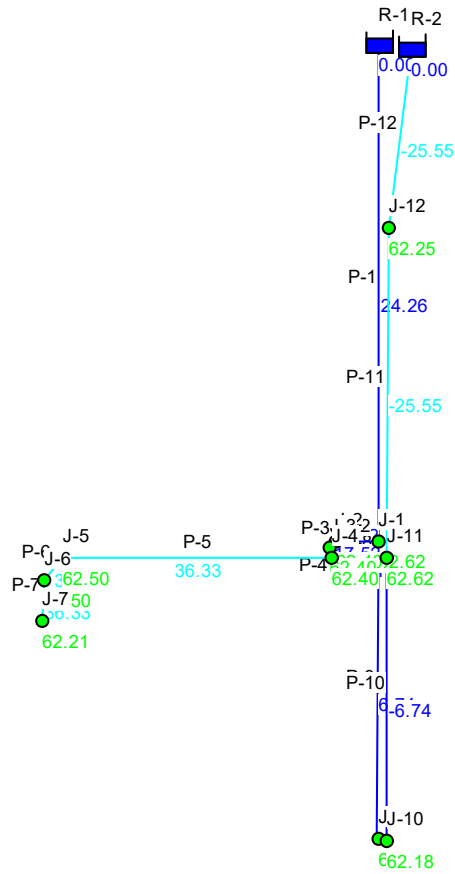
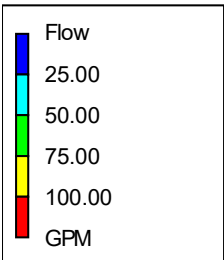
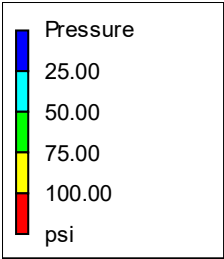

Scenario 3: Max Day + Fire Flow

```

*****
*                               E P A N E T                               *
*                               Hydraulic and Water Quality              *
*                               Analysis for Pipe Networks                *
*                               Version 2.2                              *
*****
    
```

Input File: 210691_Max Day+FF.net

Link - Node Table:

Link ID	Start Node	End Node	Length ft	Diameter in
P-1	R-1	J-1	150.88	8
P-3	J-2	J-3	2.95	4
P-4	J-3	J-4	2.95	4
P-5	J-4	J-5	80.03	4
P-6	J-5	J-6	9.84	4
P-7	J-6	J-7	13.12	4
P-8	J-4	J-11	15	4
P-9	J-1	J-9	88.56	8
P-10	J-10	J-11	85.28	8
P-11	J-11	J-12	101.68	8
P-12	J-12	R-2	54.45	8
P-2	J-1	J-2	12.5	4

Node Results:

Node ID	Demand GPM	Head ft	Pressure psi	Quality
J-1	0.00	450.67	62.62	0.00
J-2	0.00	450.66	62.40	0.00
J-3	0.00	450.66	62.40	0.00
J-4	0.00	450.66	62.40	0.00
J-5	0.00	450.59	62.50	0.00
J-6	0.00	450.58	62.50	0.00
J-7	36.33	450.57	62.21	0.00
J-9	6.74	450.67	62.18	0.00
J-10	6.74	450.67	62.18	0.00
J-11	0.00	450.67	62.62	0.00
J-12	0.00	450.67	62.25	0.00
R-1	-24.26	450.67	0.00	0.00 Reservoir
R-2	-25.55	450.67	0.00	0.00 Reservoir

Link Results:

Link ID	Flow GPM	Velocity fps	Unit Headloss ft/Kft	Status
P-1	24.26	0.15	0.01	Open
P-3	17.52	0.45	0.23	Open
P-4	17.52	0.45	0.23	Open
P-5	36.33	0.93	0.88	Open
P-6	36.33	0.93	0.88	Open
P-7	36.33	0.93	0.88	Open
P-8	-18.81	0.48	0.26	Open
P-9	6.74	0.04	0.00	Open
P-10	-6.74	0.04	0.00	Open
P-11	-25.55	0.16	0.02	Open
P-12	-25.55	0.16	0.02	Open
P-2	17.52	0.45	0.23	Open

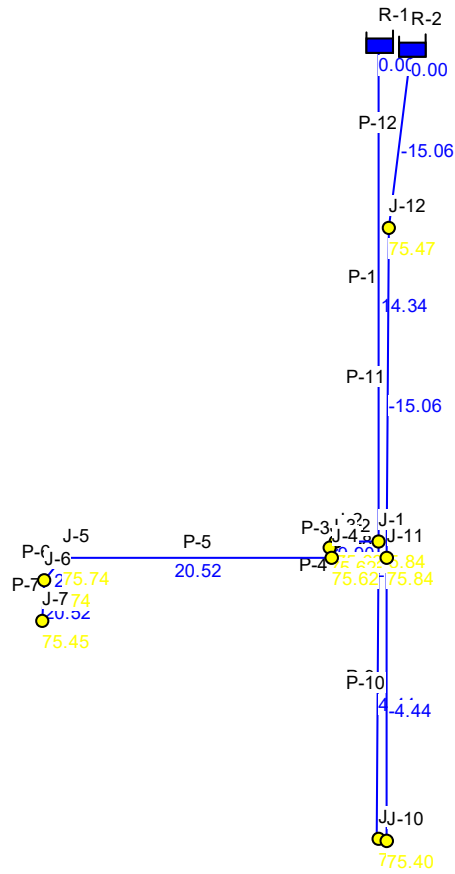
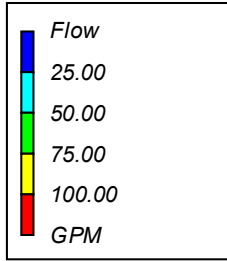
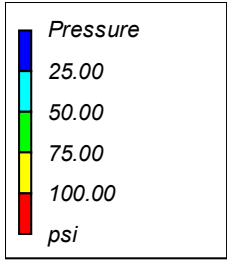

Scenario 4: Average Day (Pressure Zone SUC)

```
*****
*                               E P A N E T                               *
*                               Hydraulic and Water Quality                 *
*                               Analysis for Pipe Networks                   *
*                               Version 2.2                                 *
*****
```

Input File: 210691_Avg Day - SUC.net

Link - Node Table:

Link ID	Start Node	End Node	Length ft	Diameter in
P-1	R-1	J-1	150.88	8
P-3	J-2	J-3	2.95	4
P-4	J-3	J-4	2.95	4
P-5	J-4	J-5	80.03	4
P-6	J-5	J-6	9.84	4
P-7	J-6	J-7	13.12	4
P-8	J-4	J-11	15	4
P-9	J-1	J-9	88.56	8
P-10	J-10	J-11	85.28	8
P-11	J-11	J-12	101.68	8
P-12	J-12	R-2	54.45	8
P-2	J-1	J-2	12.5	4

Node Results:

Node ID	Demand GPM	Head ft	Pressure psi	Quality
J-1	0.00	481.18	75.84	0.00
J-2	0.00	481.18	75.62	0.00
J-3	0.00	481.18	75.62	0.00
J-4	0.00	481.18	75.62	0.00
J-5	0.00	481.15	75.74	0.00
J-6	0.00	481.15	75.74	0.00
J-7	20.52	481.15	75.45	0.00
J-9	4.44	481.18	75.40	0.00
J-10	4.44	481.18	75.40	0.00
J-11	0.00	481.18	75.84	0.00
J-12	0.00	481.18	75.47	0.00
R-1	-14.34	481.18	0.00	0.00 Reservoir
R-2	-15.06	481.18	0.00	0.00 Reservoir

Link Results:

Link ID	Flow GPM	Velocity fps	Unit Headloss ft/Kft	Status
P-1	14.34	0.09	0.01	Open
P-3	9.90	0.25	0.08	Open
P-4	9.90	0.25	0.08	Open
P-5	20.52	0.52	0.31	Open
P-6	20.52	0.52	0.31	Open
P-7	20.52	0.52	0.31	Open
P-8	-10.62	0.27	0.09	Open
P-9	4.44	0.03	0.00	Open
P-10	-4.44	0.03	0.00	Open
P-11	-15.06	0.10	0.01	Open
P-12	-15.06	0.10	0.01	Open
P-2	9.90	0.25	0.08	Open

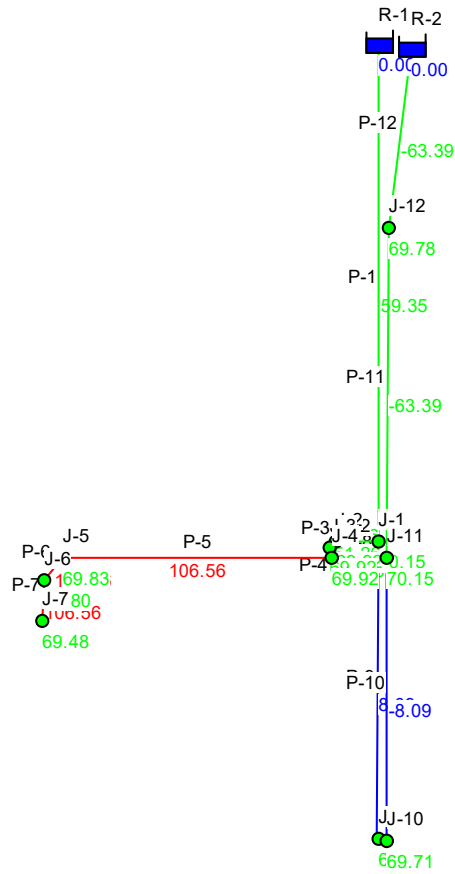
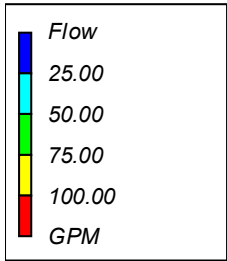
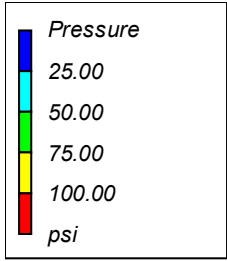

Scenario 5: Peak Hour (Pressure Zone SUC)

```

*****
*                               E P A N E T                               *
*                               Hydraulic and Water Quality                *
*                               Analysis for Pipe Networks                  *
*                               Version 2.2                               *
*****
    
```

Input File: 210691_Peak Hour - SUC.net

Link - Node Table:

Link ID	Start Node	End Node	Length ft	Diameter in
P-1	R-1	J-1	150.88	8
P-3	J-2	J-3	2.95	4
P-4	J-3	J-4	2.95	4
P-5	J-4	J-5	80.03	4
P-6	J-5	J-6	9.84	4
P-7	J-6	J-7	13.12	4
P-8	J-4	J-11	15	4
P-9	J-1	J-9	88.56	8
P-10	J-10	J-11	85.28	8
P-11	J-11	J-12	101.68	8
P-12	J-12	R-2	54.45	8
P-2	J-1	J-2	12.5	4

Node Results:

Node ID	Demand GPM	Head ft	Pressure psi	Quality
J-1	0.00	468.05	70.15	0.00
J-2	0.00	468.03	69.92	0.00
J-3	0.00	468.02	69.92	0.00
J-4	0.00	468.02	69.92	0.00
J-5	0.00	467.50	69.83	0.00
J-6	0.00	467.44	69.80	0.00
J-7	106.56	467.35	69.48	0.00
J-9	8.09	468.05	69.71	0.00
J-10	8.09	468.05	69.71	0.00
J-11	0.00	468.05	70.15	0.00
J-12	0.00	468.06	69.78	0.00
R-1	-59.35	468.06	0.00	0.00 Reservoir
R-2	-63.39	468.06	0.00	0.00 Reservoir

Link Results:

Link ID	Flow GPM	Velocity fps	Unit Headloss ft/Kft	Status
P-1	59.35	0.38	0.08	Open
P-3	51.26	1.31	1.67	Open
P-4	51.26	1.31	1.68	Open
P-5	106.56	2.72	6.49	Open
P-6	106.56	2.72	6.48	Open
P-7	106.56	2.72	6.49	Open
P-8	-55.30	1.41	1.92	Open
P-9	8.09	0.05	0.00	Open
P-10	-8.09	0.05	0.00	Open
P-11	-63.39	0.40	0.08	Open
P-12	-63.39	0.40	0.08	Open
P-2	51.26	1.31	1.67	Open

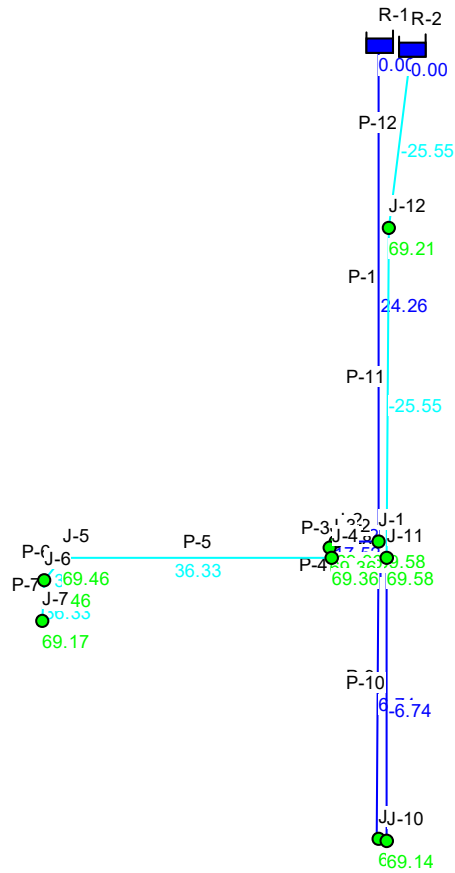
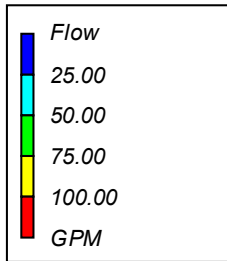
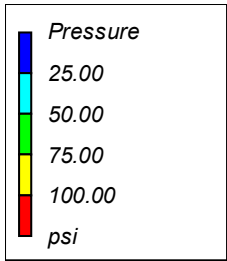

Scenario 6: Max Day + Fire Flow (Pressure Zone SUC)

```

*****
*                               E P A N E T                               *
*                               Hydraulic and Water Quality                 *
*                               Analysis for Pipe Networks                   *
*                               Version 2.2                                *
*****
    
```

Input File: 210691_Max Day+FF - SUC.net

Link - Node Table:

Link ID	Start Node	End Node	Length ft	Diameter in
P-1	R-1	J-1	150.88	8
P-3	J-2	J-3	2.95	4
P-4	J-3	J-4	2.95	4
P-5	J-4	J-5	80.03	4
P-6	J-5	J-6	9.84	4
P-7	J-6	J-7	13.12	4
P-8	J-4	J-11	15	4
P-9	J-1	J-9	88.56	8
P-10	J-10	J-11	85.28	8
P-11	J-11	J-12	101.68	8
P-12	J-12	R-2	54.45	8
P-2	J-1	J-2	12.5	4

Node Results:

Node ID	Demand GPM	Head ft	Pressure psi	Quality
J-1	0.00	466.74	69.58	0.00
J-2	0.00	466.73	69.36	0.00
J-3	0.00	466.73	69.36	0.00
J-4	0.00	466.73	69.36	0.00
J-5	0.00	466.66	69.46	0.00
J-6	0.00	466.65	69.46	0.00
J-7	36.33	466.64	69.17	0.00
J-9	6.74	466.74	69.14	0.00
J-10	6.74	466.74	69.14	0.00
J-11	0.00	466.74	69.58	0.00
J-12	0.00	466.74	69.21	0.00
R-1	-24.26	466.74	0.00	0.00 Reservoir
R-2	-25.55	466.74	0.00	0.00 Reservoir

Link Results:

Link ID	Flow GPM	Velocity fps	Unit Headloss ft/Kft	Status
P-1	24.26	0.15	0.01	Open
P-3	17.52	0.45	0.23	Open
P-4	17.52	0.45	0.24	Open
P-5	36.33	0.93	0.88	Open
P-6	36.33	0.93	0.88	Open
P-7	36.33	0.93	0.88	Open
P-8	-18.81	0.48	0.26	Open
P-9	6.74	0.04	0.00	Open
P-10	-6.74	0.04	0.00	Open
P-11	-25.55	0.16	0.02	Open
P-12	-25.55	0.16	0.02	Open
P-2	17.52	0.45	0.23	Open

APPENDIX C
Wastewater Calculations



LRL File No. 210691
Project: Proposed Development-Halo Car Wash
Location: 3535 Borrisokane Rd, Barrhaven, ON
Date: February 17, 2023

Sanitary Design Parameters

Average Daily Flow = 280 L/p/day
 Commercial & Institutional Flow = 28000 L/ha/day
 Light Industrial Flow = 35000 L/ha/day
 Heavy Industrial Flow = 55000 L/ha/day
 Maximum Residential Peak Factor = 4.0
 Commercial & Institutional Peak Factor = 1.5

Industrial Peak Factor = as per Appendix 4-B
 Extraneous Flow = 0.33 L/s/gross ha
 (as Per Tech Bulletin ISTB-2018-01)

Pipe Design Parameters

Minimum Velocity = 0.60 m/s
 Manning's n = 0.013

LOCATION			RESIDENTIAL AREA AND POPULATION						COMMERCIAL		INDUSTRIAL			INSTITUTIONAL		C+I+I	INFILTRATION			TOTAL FLOW	PIPE						
STREET/SITE	FROM MH	TO MH	AREA (Ha)	POP.	CUMMULATIVE		PEAK FLOW (l/s)	AREA (Ha)	ACCU. AREA (Ha)	AREA (Ha)	ACCU. AREA (Ha)	PEAK FACT.	AREA (Ha)	ACCU. AREA (Ha)	*PEAK FLOW (l/s)	TOTAL AREA (Ha)	ACCU. AREA (Ha)	INFILT. FLOW (l/s)	TOTAL FLOW (l/s)	LENGTH (m)	DIA. (mm)	SLOPE (%)	MATERIAL	CAP. (FULL) (l/s)	VEL. (FULL) (m/s)		
					AREA (Ha)	POP.																					
	Bldg.	SAN MH03																	0.003	1.4	150	2.00%	PVC	21.54	1.22		
	SAN MH03	SAN MH06																	0.003	14.7	150	2.00%	PVC	21.54	1.22		
	**SAN MH01	SAN MH06							0.534					6.139	0.534	0.534	0.176	6.318	19.4	150	1.26%	PVC	17.09	0.97			
	SAN MH06	SAN MH02																6.320	17.4	150	1.26%	PVC	17.09	0.97			
	*Future Dev.	SAN MH02																2.360	34.4	200	0.65%	PVC	26.44	0.84			
	SAN MH02	SAN MH04																8.680	22.6	200	0.65%	PVC	26.44	0.84			
															Designed: M. B./M.L.	PROJECT: Proposed Halo Car Wash											
															Checked: M.B.	LOCATION: 3535 Borrisokane Rd, Barrhaven, ON											
															Dwg. Reference: C401	File Ref.: 210691	Date: 2023-02-17	Sheet No. 1 of 1									

Note:
 * Peak Design Flow from Future Development (Part 3 + Part 5) was taken from Servicing Brief Prepared by Pearson Engineering, dated November 17, 2022
 **Peak flow including anticipated waste water from Halo Car Wash (6.141 L/s), see below

Site Description	Qty	L/Qty	Total	
			L/day	L/s
Halo Car Wash				
Anticipated Employees	2	75	150	0.002
Total x Peak Factor (1.5)				0.003
Estimated Car Wash/Hour (based on info by Halo Car Wash)	130	170		6.139
Total Anticipated Peak Design Flow (dry weather flow)				6.141

APPENDIX D
Stormwater Management Calculations

LRL Associates Ltd.

Storm Watershed Summary

	<p>LRL File No. 210691</p> <p>Project: Proposed Development-Halo Car Wash</p> <p>Location: 3555 Borrisokane Rd (Barrhaven, ON)</p> <p>Date: February 22, 2023</p> <p>Designed: M. Longtin</p> <p>Checked: M. Basnet</p> <p>Dwg Reference: C701, C702</p>
---	---

Pre-Development Catchments

Watershed	C = 0.20	C = 0.80	C = 0.90	Total Area (ha)	Combined C
EWS-01 (uncontrolled)	0.534	0.000	0.000	0.534	0.20
Total	0.534	0.000	0.000	0.534	0.20

Post-Development Catchments

Watershed	C = 0.20	C = 0.8	C = 0.90	Total Area (ha)	Combined C
WS-01A (controlled)	0.040	0.000	0.006	0.045	0.29
WS-01B (controlled)	0.003	0.000	0.015	0.017	0.79
WS-02 (controlled)	0.000	0.000	0.049	0.049	0.90
WS-03 (controlled)	0.001	0.000	0.028	0.030	0.87
WS-04 (controlled)	0.046	0.000	0.055	0.101	0.58
WS-05 (controlled)	0.000	0.000	0.053	0.053	0.90
WS-06 (controlled)	0.005	0.000	0.118	0.123	0.87
WS-07 (controlled)	0.008	0.000	0.031	0.039	0.76
WS-08 (controlled)	0.027	0.000	0.000	0.027	0.20
WS-09 (uncontrolled)	0.029	0.000	0.000	0.029	0.20
WS-10 (uncontrolled)	0.020	0.000	0.000	0.020	0.20
Total	0.179	0.000	0.355	0.534	0.67



LRL File No. 210691
Project: Proposed Development-Halo Car Wash
Location: 3555 Borrisokane Rd (Barrhaven, ON)
Date: February 22, 2023
Designed: M. Longtin
Checked: M. Basnet
Drawing Ref.: C701, C702

**Stormwater Management
Design Sheet**

STORM - 100 YEAR

Runoff Equation

$Q = 2.78CIA$ (L/s)
 C = Runoff coefficient
 $I = \text{Rainfall intensity (mm/hr)} = A / (Td + C)^B$
 A = Area (ha)
 $T_c = \text{Time of concentration (min)}$

Pre-Development Catchments within Development Area

	Total Area =	0.534	ha	ΣR=	0.20
Un-Controlled	EWS-01	0.534	ha	R=	0.20
	Total Uncontrolled =	0.534	ha	ΣR=	0.20

Pre-development Stormwater Management (5-Yr)

$I_5 = 998.071 / (Td + 6.053)^{0.814}$ **A = 998.071** **B = 0.814** **C = 6.053**

C = 0.20 max of 0.5 as per City of Ottawa
 I = 104.2 mm/hr
 Tc = 10 min
 Total Area = 0.534 ha
 Release Rate = 30.95 L/s

Pre-development Stormwater Management (100-Yr)

$I_{100} = 1735.688 / (Td + 6.014)^{0.820}$ **A = 1735.688** **B = 0.820** **C = 6.014**

C = 0.20
 I = 178.6 mm/hr
 Tc = 10 min
 Total Area = 0.534 ha
 Release Rate = 52.99 L/s

Allowable Release Rate = 30.95 L/s
 (5-yr pre-development level corresponding to EWS-01, see drawing C701)

Post-development Stormwater Management

					ΣR _{2&5}	ΣR ₁₀₀
	Total Site Area =	0.534	ha	ΣR=	0.67	0.83
Controlled	WS-01A	0.045	ha	R=	0.29	0.36
	WS-01B	0.017	ha	R=	0.79	0.99
	WS-02	0.049	ha	R=	0.90	1.00
	WS-03	0.030	ha	R=	0.87	1.00
	WS-04	0.101	ha	R=	0.58	0.73
	WS-05	0.053	ha	R=	0.90	1.00
	WS-06	0.123	ha	R=	0.87	1.00
	WS-07	0.039	ha	R=	0.76	0.95
	WS-08	0.027	ha	R=	0.20	0.25
	Total Controlled =	0.485	ha	ΣR=	0.71	0.89
Uncontrolled	WS-09	0.029	ha	R=	0.20	0.25
	WS-10	0.020	ha	R=	0.20	0.25
	Total Uncontrolled =	0.049	ha	ΣR=	0.20	0.25

Post-development Stormwater Management (100-Yr)

Time (min)	Intensity (mm/hr)	Controlled Runoff (L/s)	Storage Volume (m³)	*Controlled Release Rate (L/s)	Uncontrolled Runoff (L/s)	Total Release Rate (L/s)
10	178.56	214.24	121.09	12.43	6.09	18.52
15	142.89	171.45	143.12	12.43	4.88	17.31
20	119.95	143.92	157.79	12.43	4.09	16.52
25	103.85	124.60	168.26	12.43	3.54	15.97
30	91.87	110.23	176.04	12.43	3.13	15.56
35	82.58	99.08	181.97	12.43	2.82	15.25
40	75.15	90.16	186.56	12.43	2.56	14.99
45	69.05	82.85	190.13	12.43	2.36	14.79
50	63.95	76.74	192.92	12.43	2.18	14.61
55	59.62	71.54	195.06	12.43	2.03	14.46
60	55.89	67.07	196.69	12.43	1.91	14.34
65	52.65	63.17	197.88	12.43	1.80	14.23
70	49.79	59.74	198.70	12.43	1.70	14.13
75	47.26	56.70	199.21	12.43	1.61	14.04
80	44.99	53.98	199.45	12.43	1.54	13.97
85	42.95	51.54	199.45	12.43	1.47	13.90
90	41.11	49.33	199.24	12.43	1.40	13.83
95	39.43	47.32	198.85	12.43	1.35	13.78
100	37.90	45.48	198.29	12.43	1.29	13.72
105	36.50	43.79	197.58	12.43	1.25	13.68
110	35.20	42.24	196.73	12.43	1.20	13.63
115	34.01	40.80	195.76	12.43	1.16	13.59
120	32.89	39.47	194.68	12.43	1.12	13.55

*Average release rate taken as 50% of max. allowable controlled release rate

On-site stormwater detention

Storage required = 199.45 m³
 Surface storage provided = 161.98 m³ (See Dwg C601)
 Underground storage provided = 49.18 m³ (See 2-Yr STM Design Sheet)
Total storage provided = 211.16 m³



LRL File No. 210691
 Project: Proposed Development-Halo Car Wash
 Location: 3555 Borrisokane Rd (Barrhaven, ON)
 Date: February 22, 2023
 Designed: M. Longtin
 Checked: M. Basnet
 Drawing Ref.: C701, C702

Stormwater Management
 Design Sheet

STORM - 5 YEAR

Runoff Equation

Q = 2.78CIA (L/s)
 C = Runoff coefficient
 I = Rainfall intensity (mm/hr) = A / (Td + C)^B
 A = Area (ha)
 T_c = Time of concentration (min)

Pre-Development Catchments within Development Area

Un-Controlled	Total Area =	0.534	ha	ΣR=	0.20
	EWS-01	0.534	ha	R=	0.20
	Total Uncontrolled =	0.534	ha	ΣR=	0.20

Pre-development Stormwater Management (5-Yr)

$I_5 = 998.071 / (Td + 6.053)^{0.814}$ A = 998.071 B = 0.814 C = 6.053

C = 0.20 max of 0.5 as per City of Ottawa
 I = 104.2 mm/hr
 T_c = 10 min
 Total Area = 0.534 ha
 Release Rate = 30.95 L/s

Pre-development Stormwater Management (100-Yr)

$I_{100} = 1735.688 / (Td + 6.014)^{0.820}$ A = 1735.688 B = 0.820 C = 6.014

C = 0.20
 I = 178.6 mm/hr
 T_c = 10 min
 Total Area = 0.534 ha
 Release Rate = 52.99 L/s

Allowable Release Rate = 30.95 L/s

(5-yr pre-development level corresponding to EWS-01, see drawing C701)

Post-development Stormwater Management

				ΣR _{2&5}	ΣR ₁₀₀		
Controlled	Total Site Area =	0.534	ha	ΣR=	0.67		
	WS-01A	0.045	ha	R=	0.29		
	WS-01B	0.017	ha	R=	0.79		
	WS-02	0.049	ha	R=	0.90		
	WS-03	0.030	ha	R=	0.87		
	WS-04	0.101	ha	R=	0.58		
	WS-05	0.053	ha	R=	0.90		
	WS-06	0.123	ha	R=	0.87		
	WS-07	0.039	ha	R=	0.76		
	WS-08	0.027	ha	R=	0.20		
Total Controlled =				0.485	ha	ΣR=	0.71
Uncontrolled	WS-09	0.029	ha	R=	0.20		
	WS-10	0.020	ha	R=	0.20		
	Total Uncontrolled =	0.049	ha	ΣR=	0.20		

Post-development Stormwater Management (5-Yr)

Time (min)	Intensity (mm/hr)	Controlled Runoff (L/s)	Storage Volume (m ³)	*Controlled Release Rate (L/s)	Uncontrolled Runoff (L/s)	Total Release Rate (L/s)
10	104.19	100.01	52.55	12.43	2.84	15.27
15	83.56	80.20	61.00	12.43	2.28	14.71
20	70.25	67.43	66.00	12.43	1.92	14.35
25	60.90	58.45	69.03	12.43	1.66	14.09
30	53.93	51.76	70.80	12.43	1.47	13.90
35	48.52	46.57	71.70	12.43	1.32	13.75
40	44.18	42.41	71.96	12.43	1.21	13.64
45	40.63	39.00	71.74	12.43	1.11	13.54
50	37.65	36.14	71.14	12.43	1.03	13.46
55	35.12	33.71	70.24	12.43	0.96	13.39
60	32.94	31.62	69.09	12.43	0.90	13.33
65	31.04	29.80	67.74	12.43	0.85	13.28
70	29.37	28.19	66.21	12.43	0.80	13.23
75	27.89	26.77	64.53	12.43	0.76	13.19
80	26.56	25.50	62.72	12.43	0.73	13.15
85	25.37	24.35	60.80	12.43	0.69	13.12
90	24.29	23.31	58.77	12.43	0.66	13.09
95	23.31	22.37	56.66	12.43	0.64	13.07
100	22.41	21.51	54.47	12.43	0.61	13.04
105	21.58	20.72	52.21	12.43	0.59	13.02
110	20.82	19.99	49.88	12.43	0.57	13.00
115	20.12	19.31	47.49	12.43	0.55	12.98
120	19.47	18.69	45.05	12.43	0.53	12.96

*Average release rate taken as 50% of max. allowable controlled release rate

On-site stormwater detention

Storage required = 71.96 m³
 Surface storage provided = 161.98 m³ (See Dwg C601)
 Underground Storage provided = 49.18 m³ (See 2-Yr STM Design Sheet)
 Total storage provided = 211.16 m³



LRL File No. 210691
Project: Proposed Development-Halo Car Wash
Location: 3555 Borrisokane Rd (Barrhaven, ON)
Date: February 22, 2023
Designed: M. Longtin
Checked: M. Basnet
Drawing Ref.: C701, C702

**Stormwater Management
Design Sheet**

STORM - 2 YEAR

Runoff Equation

Q = 2.78CIA (L/s)
 C = Runoff coefficient
 I = Rainfall intensity (mm/hr) = $A / (Td + C)^B$
 A = Area (ha)
 T_c = Time of concentration (min)

Pre-Development Catchments within Development Area

	Total Area =	0.534	ha	ΣR=	0.20
Un-Controlled	EWS-01	0.534	ha	R=	0.20
	Total Uncontrolled =	0.534	ha	ΣR=	0.20

Pre-development Stormwater Management (2-Yr)

$I_2 = 732.951 / (Td + 6.199)^{0.810}$
A = **732.951**
B = **0.810**
C = **6.199**

C = 0.20 max of 0.5 as per City of Ottawa
 I = 76.8 mm/hr
 T_c = 10 min
 Total Area = 0.534 ha
 Release Rate = 22.82 L/s

Pre-development Stormwater Management (5-Yr)

$I_5 = 998.071 / (Td + 6.053)^{0.814}$
A = **998.071**
B = **0.814**
C = **6.053**

C = 0.20 max of 0.5 as per City of Ottawa
 I = 104.2 mm/hr
 T_c = 10 min
 Total Area = 0.534 ha
 Release Rate = 30.95 L/s

Pre-development Stormwater Management (100-Yr)

$I_{100} = 1735.688 / (Td + 6.014)^{0.820}$
A = **1735.688**
B = **0.820**
C = **6.014**

C = 0.20 max of 0.5 as per City of Ottawa
 I = 178.6 mm/hr
 T_c = 10 min
 Total Area = 0.534 ha
 Release Rate = 52.99 L/s

Allowable Release Rate = 30.95 L/s
 (5-yr pre-development level corresponding to EWS-01, see drawing C701)

Post-development Stormwater Management

					ΣR _{2&5}	ΣR ₁₀₀
	Total Site Area =	0.534	ha	ΣR=	0.67	0.83
Controlled	WS-01A	0.045	ha	R=	0.29	0.36
	WS-01B	0.017	ha	R=	0.79	0.99
	WS-02	0.049	ha	R=	0.90	1.00
	WS-03	0.030	ha	R=	0.87	1.00
	WS-04	0.101	ha	R=	0.58	0.73
	WS-05	0.053	ha	R=	0.90	1.00
	WS-06	0.123	ha	R=	0.87	1.00
	WS-07	0.039	ha	R=	0.76	0.95
	WS-08	0.027	ha	R=	0.20	0.25
	Total Controlled =	0.485	ha	ΣR=	0.71	0.89
Uncontrolled	WS-09	0.029	ha	R=	0.20	0.25
	WS-10	0.020	ha	R=	0.20	0.25
	Total Uncontrolled =	0.049	ha	ΣR=	0.20	0.25



LRL File No. 210691
Project: Proposed Development-Halo Car Wash
Location: 3555 Borrisokane Rd (Barrhaven, ON)
Date: February 22, 2023
Designed: M. Longtin
Checked: M. Basnet
Drawing Ref.: C701, C702

**Stormwater Management
Design Sheet**

Post-development Stormwater Management (2-Yr)

Time (min)	Intensity (mm/hr)	Controlled Runoff (L/s)	Storage Volume (m ³)	*Controlled Release Rate (L/s)	Uncontrolled Runoff (L/s)	Total Release Rate (L/s)
10	76.81	73.72	36.78	12.43	2.10	14.53
15	61.77	59.29	42.17	12.43	1.69	14.12
20	52.03	49.94	45.02	12.43	1.42	13.85
25	45.17	43.35	46.39	12.43	1.23	13.66
30	40.04	38.44	46.81	12.43	1.09	13.52
35	36.06	34.61	46.58	12.43	0.98	13.41
40	32.86	31.55	45.88	12.43	0.90	13.33
45	30.24	29.03	44.81	12.43	0.83	13.26
50	28.04	26.92	43.46	12.43	0.77	13.20
55	26.17	25.12	41.88	12.43	0.71	13.14
60	24.56	23.57	40.11	12.43	0.67	13.10
65	23.15	22.22	38.19	12.43	0.63	13.06
70	21.91	21.03	36.14	12.43	0.60	13.03
75	20.81	19.98	33.97	12.43	0.57	13.00
80	19.83	19.03	31.70	12.43	0.54	12.97
85	18.94	18.18	29.35	12.43	0.52	12.95
90	18.14	17.41	26.92	12.43	0.50	12.93
95	17.41	16.71	24.42	12.43	0.48	12.91
100	16.75	16.07	21.87	12.43	0.46	12.89
105	16.13	15.49	19.26	12.43	0.44	12.87
110	15.57	14.94	16.60	12.43	0.43	12.85
115	15.05	14.44	13.89	12.43	0.41	12.84
120	14.56	13.98	11.15	12.43	0.40	12.83

*Average release rate taken as 50% of max. allowable controlled release rate

On-site stormwater detention

Storage required =	46.81	m³	
Underground Storage provided =	49.18	m ³	(oversized pipe storage & CB/MH/CBMH storage)
Rear Yard Storage provided =	3.87	m ³	
Total storage provided =	53.05	m³	

Pipe Storage

Length (m)	dia. (m)	Storage (m ³)
156.60	0.450	24.92
8.40	0.300	0.59
Total		25.51

MH/CBMH Storage

CB/CBMH	Depth (m)	dia. (m)	Storage (m ³)
CBMH01	1.00	1.20	1.13
CBMH02	1.07	1.20	1.21
CBMH03	1.23	1.50	2.17
CBMH04	1.23	1.20	1.39
CBMH05	1.35	1.50	2.39
CBMH06	1.50	1.20	1.70
CBMH07	1.47	1.20	1.66
MH08	1.63	1.80	4.15
CBMH10	1.74	1.80	4.43
CB11	1.08	0.6*0.6	0.39
CBMH12	1.15	1.20	1.30
CBMH09	1.54	1.20	1.74
Total			23.67

LRL Associates Ltd.
Storm Design Sheet



LRL File No. 210691
Project: Proposed Development-Halo Car Wash
Location: 3555 Borrisokane Rd (Barrhaven, ON)
Date: February 22, 2023
Designed: M. Longtin
Checked: M. Basnet
Drawing Reference: C702, C401

Storm Design Parameters

Rational Method

Q = 2.78CIA
 Q = Peak flow (L/s)
 A = Drainage area (ha)
 C = Runoff coefficient
 I = Rainfall intensity (mm/hr)

Runoff Coefficient (C)

Grass 0.20
 Gravel 0.80
 Asphalt / rooftop 0.90

City of Ottawa IDF curve equation

(5 year event, intensity in mm/hr)
 $I_5 = 998.071 / (Td + 6.053)^{0.814}$
 Min. velocity = 0.80 m/s
 Manning's "n" = 0.013

LOCATION			AREA (ha)			FLOW						STORM SEWER							
WATERSHED / STREET	From MH	To MH	C = 0.20	C = 0.80	C = 0.90	Indiv. 2.78AC	Accum. 2.78AC	Time of Conc. (min.)	Rainfall Intensity (mm/hr)	Peak Flow Q (L/s)	Controlled Flow Q (L/s)	Pipe Diameter (mm)	Type	Slope (%)	Length (m)	Capacity Full (L/s)	Velocity Full (m/s)	Time of Flow (min.)	Ratio (Q/Q _{FULL})
WS-01A	CBMH01	CBMH02	0.040	0.000	0.006	0.04	0.04	10.00	104.19	3.73		450	PVC	0.50%	8.60	201.6	1.27	0.11	0.02
WS-01B	CBMH02	CBMH03	0.003	0.000	0.015	0.04	0.07	10.11	103.60	7.65		450	PVC	0.45%	22.9	191.3	1.20	0.32	0.04
WS-02	CB11	CBMH12	0.000	0.000	0.049	0.12	0.12	10.00	104.19	12.83		450	PVC	0.50%	8.4	201.6	1.27	0.11	0.06
		CBMH12					0.12	10.11	103.61	12.75		450	PVC	0.50%	10.4	201.6	1.27	0.14	0.06
WS-03	CBMH03	CBMH05	0.001	0.000	0.028	0.07	0.27	10.25	102.91	27.60		450	PVC	0.45%	16.7	191.3	1.20	0.23	0.14
WS-04	CBMH04	CBMH05	0.046	0.000	0.055	0.16	0.16	10.00	104.19	17.02		450	PVC	0.45%	14.9	191.3	1.20	0.21	0.09
WS-05	CBMH05	CBMH06	0.000	0.000	0.053	0.13	0.56	10.32	102.55	57.94		450	PVC	0.35%	21.7	168.7	1.06	0.34	0.34
WS-06	CBMH06	MH08	0.005	0.000	0.118	0.30	0.86	10.66	100.84	87.02		450	PVC	0.32%	21.8	161.3	1.01	0.36	0.54
WS-07	CBMH07	MH08	0.008	0.000	0.031	0.08	0.08	10.00	104.19	8.52		450	PVC	0.45%	10.0	191.3	1.20	0.14	0.04
		MH08					0.94	10.80	100.17	94.63		450	PVC	0.36%	13.5	171.1	1.08	0.21	0.55
WS-08	CBMH9	CBMH10	0.027	0.000	0.000	0.02	0.02	10.00	104.19	1.58		450	PVC	0.50%	16.1	201.6	1.27	0.21	0.01
		CBMH10/ICD					0.96	11.01	99.16	95.19	24.86	250	PVC	0.94%	2.1	57.7	1.17	0.03	0.43
	OGS	Ex. STM					0.96	11.04	99.02	95.05	24.86	250	PVC	0.44%	11.8	39.4	0.80	0.24	0.63

Note

The Peak flow will be controlled by an ICD at the outlet of STM CBMH10



STANDARD OFFLINE Jellyfish Filter Sizing Report

Project Information

Date	Wednesday, October 19, 2022
Project Name	3555 Borrisokane Rd.
Project Number	210691
Location	Barrhaven

Jellyfish Filter Design Overview

This report provides information for the sizing and specification of the Jellyfish Filter. When designed properly in accordance to the guidelines detailed in the Jellyfish Filter Technical Manual, the Jellyfish Filter will exceed the performance and longevity of conventional horizontal bed and granular media filters.

Please see www.ImbriumSystems.com for more information.

Jellyfish Filter System Recommendation

The Jellyfish Filter model JF4-2-1 is recommended to meet the water quality objective by treating a flow of 12.6 L/s, which meets or exceeds 90% of the average annual rainfall runoff volume based on 36 years of OTTAWA MACDONALD-CARTIER INT'L A rainfall data for this site. This model has a sediment capacity of 142 kg, which meets or exceeds the estimated average annual sediment load.

Jellyfish Model	Number of High-Flo Cartridges	Number of Draindown Cartridges	Manhole Diameter (m)	Treatment Flow Rate (L/s)	Sediment Capacity (kg)
JF4-2-1	2	1	1.2	12.6	142

The Jellyfish Filter System

The patented Jellyfish Filter is an engineered stormwater quality treatment technology featuring unique membrane filtration in a compact stand-alone treatment system that removes a high level and wide variety of stormwater pollutants. Exceptional pollutant removal is achieved at high treatment flow rates with minimal head loss and low maintenance costs. Each lightweight Jellyfish Filter cartridge contains an extraordinarily large amount of membrane surface area, resulting in superior flow capacity and pollutant removal capacity.

Maintenance

Regular scheduled inspections and maintenance is necessary to assure proper functioning of the Jellyfish Filter. The maintenance interval is designed to be a minimum of 12 months, but this will vary depending on site loading conditions and upstream pretreatment measures. Quarterly inspections and inspections after all storms beyond the 5-year event are recommended until enough historical performance data has been logged to comfortably initiate an alternative inspection interval.

Please see www.ImbriumSystems.com for more information.

Thank you for the opportunity to present this information to you and your client.

Performance

Jellyfish efficiently captures a high level of Stormwater pollutants, including:

- ☑ 89% of the total suspended solids (TSS) load, including particles less than 5 microns
- ☑ 77% TP removal & 51% TN removal
- ☑ 90% Total Copper, 81% Total Lead, 70% Total Zinc
- ☑ Particulate-bound pollutants such as nutrients, toxic metals, hydrocarbons and bacteria
- ☑ Free oil, Floatable trash and debris

Field Proven Performance

The Jellyfish filter has been field-tested on an urban site with 25 TARP qualifying rain events and field monitored according to the TARP field test protocol, demonstrating:

- A median TSS removal efficiency of 89%, and a median SSC removal of 99%;
- The ability to capture fine particles as indicated by an effluent d50 median of 3 microns for all monitored storm events, and a median effluent turbidity of 5 NTUs;
- A median Total Phosphorus removal of 77%, and a median Total Nitrogen removal of 51%.

Jellyfish Filter Treatment Functions

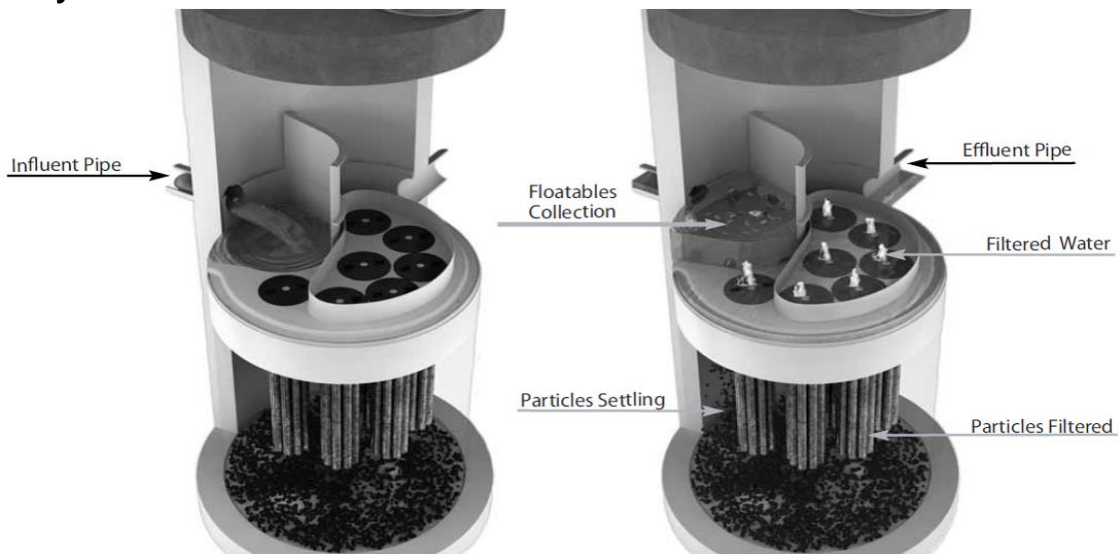

Pre-treatment and Membrane Filtration

Project Information

Date:	Wednesday, October 19, 2022
Project Name:	3555 Borrisokane Rd.
Project Number:	210691
Location:	Barrhaven

Designer Information

Company:	LRL Associates Ltd.
Contact:	Mohan Basnet
Phone #:	

Notes

--

Design System Requirements

Flow Loading	90% of the Average Annual Runoff based on 36 years of OTTAWA MACDONALD-CARTIER INT'L A rainfall	8.5 L/s
Sediment Loading	Treating 90% of the average annual runoff volume, 1664 m³, with a suspended sediment concentration of 60 mg/L.	100 kg

Recommendation

The Jellyfish Filter model JF4-2-1 is recommended to meet the water quality objective by treating a flow of 12.6 L/s, which meets or exceeds 90% of the average annual rainfall runoff volume based on 36 years of OTTAWA MACDONALD-CARTIER INT'L A rainfall data for this site. This model has a sediment capacity of 142 kg, which meets or exceeds the estimated average annual sediment load.

Jellyfish Model	Number of High-Flo Cartridges	Number of Draindown Cartridges	Manhole Diameter (m)	Wet Vol Below Deck (L)	Sump Storage (m³)	Oil Capacity (L)	Treatment Flow Rate (L/s)	Sediment Capacity (kg)
JF4-1-1	1	1	1.2	2313	0.34	379	7.6	85
JF4-2-1	2	1	1.2	2313	0.34	379	12.6	142
JF6-3-1	3	1	1.8	5205	0.79	848	17.7	199
JF6-4-1	4	1	1.8	5205	0.79	848	22.7	256
JF6-5-1	5	1	1.8	5205	0.79	848	27.8	313
JF6-6-1	6	1	1.8	5205	0.79	848	28.6	370
JF8-6-2	6	2	2.4	9252	1.42	1469	35.3	398
JF8-7-2	7	2	2.4	9252	1.42	1469	40.4	455
JF8-8-2	8	2	2.4	9252	1.42	1469	45.4	512
JF8-9-2	9	2	2.4	9252	1.42	1469	50.5	569
JF8-10-2	10	2	2.4	9252	1.42	1469	50.5	626
JF10-11-3	11	3	3.0	14456	2.21	2302	63.1	711
JF10-12-3	12	3	3.0	14456	2.21	2302	68.2	768
JF10-12-4	12	4	3.0	14456	2.21	2302	70.7	796
JF10-13-4	13	4	3.0	14456	2.21	2302	75.7	853
JF10-14-4	14	4	3.0	14456	2.21	2302	78.9	910
JF10-15-4	15	4	3.0	14456	2.21	2302	78.9	967
JF10-16-4	16	4	3.0	14456	2.21	2302	78.9	1024
JF10-17-4	17	4	3.0	14456	2.21	2302	78.9	1081
JF10-18-4	18	4	3.0	14456	2.21	2302	78.9	1138
JF10-19-4	19	4	3.0	14456	2.21	2302	78.9	1195
JF12-20-5	20	5	3.6	20820	3.2	2771	113.6	1280
JF12-21-5	21	5	3.6	20820	3.2	2771	113.7	1337
JF12-22-5	22	5	3.6	20820	3.2	2771	113.7	1394
JF12-23-5	23	5	3.6	20820	3.2	2771	113.7	1451
JF12-24-5	24	5	3.6	20820	3.2	2771	113.7	1508
JF12-25-5	25	5	3.6	20820	3.2	2771	113.7	1565
JF12-26-5	26	5	3.6	20820	3.2	2771	113.7	1622
JF12-27-5	27	5	3.6	20820	3.2	2771	113.7	1679

Rainfall

Name:	OTTAWA MACDONALD-CARTIER INT'L A
State:	ON
ID:	6000
Record:	1967 to 2003
Co-ords:	45°19'N, 75°40'W

Drainage Area

Total Area:	0.487 ha
Runoff Coefficient:	0.7

Upstream Detention

Peak Release Rate:	n/a
Pretreatment Credit:	n/a

Jellyfish Filter Design Notes

- Typically the Jellyfish Filter is designed in an offline configuration, as all stormwater filter systems will perform for a longer duration between required maintenance services when designed and applied in off-line configurations. Depending on the design parameters, an optional internal bypass may be incorporated into the Jellyfish Filter, however note the inspection and maintenance frequency should be expected to increase above that of an off-line system. Speak to your local representative for more information.

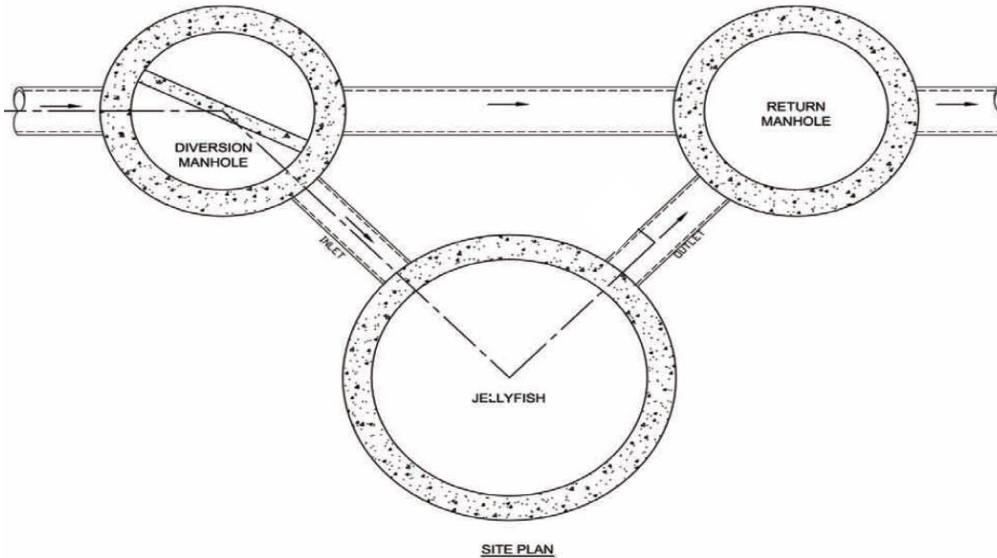

Jellyfish Filter Typical Layout

- Typically, 18 inches (457 mm) of driving head is designed into the system, calculated as the difference in elevation between the top of the diversion structure weir and the invert of the Jellyfish Filter outlet pipe. Alternative driving head values can be designed as 12 to 24 inches (305 to 610mm) depending on specific site requirements, requiring additional sizing and design assistance.
- Typically, the Jellyfish Filter is designed with the inlet pipe configured 6 inches (150 mm) above the outlet invert elevation. However, depending on site parameters this can vary to an optional configuration of the inlet pipe entering the unit below the outlet invert elevation.
- The Jellyfish Filter can accommodate multiple inlet pipes within certain restrictions.
- While the optional inlet below deck configuration offers 0 to 360 degree flexibility between the inlet and outlet pipe, typical systems conform to the following:

Model Diameter (m)	Minimum Angle Inlet / Outlet Pipes	Minimum Inlet Pipe Diameter (mm)	Minimum Outlet Pipe Diameter (mm)
1.2	62°	150	200
1.8	59°	200	250
2.4	52°	250	300
3.0	48°	300	450
3.6	40°	300	450

- The Jellyfish Filter can be built at all depths of cover generally associated with conventional stormwater conveyance systems. For sites that require minimal depth of cover for the stormwater infrastructure, the Jellyfish Filter can be applied in a shallow application using a hatch cover. The general minimum depth of cover is 36 inches (915 mm) from top of the underslab to outlet invert.
- If driving head calculations account for water elevation during submerged conditions the Jellyfish Filter will function effectively under submerged conditions.
- Jellyfish Filter systems may incorporate grated inlets depending on system configuration.
- For sites with water quality treatment flow rates or mass loadings that exceed the design flow rate of the largest standard Jellyfish Filter manhole models, systems can be designed that hydraulically connect multiple Jellyfish Filters in series or alternatively Jellyfish Vault units can be designed.

STANDARD SPECIFICATION STORMWATER QUALITY – MEMBRANE FILTRATION TREATMENT DEVICE

PART 1 – GENERAL

1.1 WORK INCLUDED

Specifies requirements for construction and performance of an underground stormwater quality membrane filtration treatment device that removes pollutants from stormwater runoff through the unit operations of sedimentation, floatation, and membrane filtration.

1.2 REFERENCE STANDARDS

ASTM C 891: Specification for Installation of Underground Precast Concrete Utility Structures
ASTM C 478: Specification for Precast Reinforced Concrete Manhole Sections
ASTM C 443: Specification for Joints for Concrete Pipe and Manholes, Using Rubber Gaskets
ASTM D 4101: Specification for Copolymer steps construction

CAN/CSA-A257.4-M92

Joints for Circular Concrete Sewer and Culvert Pipe, Manhole Sections and Fittings Using Rubber Gaskets

CAN/CSA-A257.4-M92

Precast Reinforced Circular Concrete Manhole Sections, Catch Basins and Fittings

Canadian Highway Bridge Design Code

1.3 SHOP DRAWINGS

Shop drawings for the structure and performance are to be submitted with each order to the contractor. Contractor shall forward shop drawing submittal to the consulting engineer for approval. Shop drawings are to detail the structure's precast concrete and call out or note the fiberglass (FRP) internals/components.

1.4 PRODUCT SUBSTITUTIONS

No product substitutions shall be accepted unless submitted 10 days prior to project bid date, or as directed by the engineer of record. Submissions for substitutions require review and approval by the Engineer of Record, for hydraulic performance, impact to project designs, equivalent treatment performance, and any required project plan and report (hydrology/hydraulic, water quality, stormwater pollution) modifications that would be required by the approving jurisdictions/agencies. Contractor to coordinate with the Engineer of Record any applicable modifications to the project estimates of cost, bonding amount determinations, plan check fees for changes to approved documents, and/or any other regulatory requirements resulting from the product substitution.

1.5 HANDLING AND STORAGE

Prevent damage to materials during storage and handling.

PART 2 – PRODUCTS

2.1 GENERAL

- 2.1.1 The device shall be a cylindrical or rectangular, all concrete structure (including risers), constructed from precast concrete riser and slab components or monolithic precast structure(s), installed to conform to ASTM C 891 and to any required state highway, municipal or local specifications; whichever is more stringent. The device shall be watertight.
- 2.1.2 Cartridge Deck The cylindrical concrete device shall include a fiberglass deck. The rectangular concrete device shall include a coated aluminum deck. In either instance, the insert shall be bolted and sealed watertight inside the precast concrete chamber. The deck shall serve as: (a) a horizontal divider between the lower treatment zone and the upper treated effluent zone; (b) a deck for attachment of filter cartridges such that the membrane filter elements of each cartridge extend into the lower treatment zone; (c) a platform for maintenance workers to service the filter cartridges (maximum manned weight = 450 pounds (204 kg)); (d) a conduit for conveyance of treated water to the effluent pipe.
- 2.1.3 Membrane Filter Cartridges Filter cartridges shall be comprised of reusable cylindrical membrane filter elements connected to a perforated head plate. The number of membrane filter elements per cartridge shall be a minimum of eleven 2.75-inch (70-mm) diameter elements. The length of each filter element shall be a minimum 15 inches (381 mm). Each cartridge shall be fitted into the cartridge deck by insertion into a cartridge receptacle that is permanently mounted into the cartridge deck. Each cartridge shall be secured by a cartridge lid that is threaded onto the receptacle, or similar mechanism to secure the cartridge into the deck. The maximum treatment flow rate of a filter cartridge shall be controlled by an orifice in the cartridge lid, or on the individual cartridge itself, and based on a design flux rate (surface loading rate) determined by the maximum treatment flow rate per unit of filtration membrane surface area. The maximum design flux rate shall be 0.21 gpm/ft² (0.142 lps/m²).

Each membrane filter cartridge shall allow for manual installation and removal. Each filter cartridge shall have filtration membrane surface area and dry installation weight as follows (if length of filter cartridge is between those listed below, the surface area and weight shall be proportionate to the next length shorter and next length longer as shown below):

Filter Cartridge Length (in / mm)	Minimum Filtration Membrane Surface Area (ft ² / m ²)	Maximum Filter Cartridge Dry Weight (lbs / kg)
15	106 / 9.8	10.5 / 4.8
27	190 / 17.7	15.0 / 6.8
40	282 / 26.2	20.5 / 9.3
54	381 / 35.4	25.5 / 11.6

- 2.1.4 Backwashing Cartridges The filter device shall have a weir extending above the cartridge deck, or other mechanism, that encloses the high flow rate filter cartridges when placed in their respective cartridge receptacles within the cartridge deck. The weir, or other mechanism, shall collect a pool of filtered water during inflow events that backwashes the high flow rate cartridges when the inflow

event subsides. All filter cartridges and membranes shall be reusable and allow for the use of filtration membrane rinsing procedures to restore flow capacity and sediment capacity; extending cartridge service life.

- 2.1.5 Maintenance Access to Captured Pollutants The filter device shall contain an opening(s) that provides maintenance access for removal of accumulated floatable pollutants and sediment, removal of and replacement of filter cartridges, cleaning of the sump, and rinsing of the deck. Access shall have a minimum clear vertical clear space over all of the filter cartridges. Filter cartridges shall be able to be lifted straight vertically out of the receptacles and deck for the entire length of the cartridge.
- 2.1.6 Bend Structure The device shall be able to be used as a bend structure with minimum angles between inlet and outlet pipes of 90-degrees or less in the stormwater conveyance system.
- 2.1.7 Double-Wall Containment of Hydrocarbons The cylindrical precast concrete device shall provide double-wall containment for hydrocarbon spill capture by a combined means of an inner wall of fiberglass, to a minimum depth of 12 inches (305 mm) below the cartridge deck, and the precast vessel wall.
- 2.1.8 Baffle The filter device shall provide a baffle that extends from the underside of the cartridge deck to a minimum length equal to the length of the membrane filter elements. The baffle shall serve to protect the membrane filter elements from contamination by floatables and coarse sediment. The baffle shall be flexible and continuous in cylindrical configurations, and shall be a straight concrete or aluminum wall in rectangular configurations.
- 2.1.9 Sump The device shall include a minimum 24 inches (610 mm) of sump below the bottom of the cartridges for sediment accumulation, unless otherwise specified by the design engineer. Depths less than 24 inches may have an impact on the total performance and/or longevity between cartridge maintenance/replacement of the device.

2.2 PRECAST CONCRETE SECTIONS

All precast concrete components shall be manufactured to a minimum live load of HS-20 truck loading or greater based on local regulatory specifications, unless otherwise modified or specified by the design engineer, and shall be watertight.

2.3 JOINTS All precast concrete manhole configuration joints shall use nitrile rubber gaskets and shall meet the requirements of ASTM C443, Specification C1619, Class D or engineer approved equal to ensure oil resistance. Mastic sealants or butyl tape are not an acceptable alternative.

2.4 GASKETS Only profile neoprene or nitrile rubber gaskets in accordance to CSA A257.3-M92 will be accepted. Mastic sealants, butyl tape or Con Seal CS-101 are not acceptable gasket materials.

2.5 FRAME AND COVER Frame and covers must be manufactured from cast-iron or other composite material tested to withstand H-20 or greater design loads, and as approved by the

local regulatory body. Frames and covers must be embossed with the name of the device manufacturer or the device brand name.

- 2.6 DOORS AND HATCHES If provided shall meet designated loading requirements or at a minimum for incidental vehicular traffic.
- 2.7 CONCRETE All concrete components shall be manufactured according to local specifications and shall meet the requirements of ASTM C 478.
- 2.8 FIBERGLASS The fiberglass portion of the filter device shall be constructed in accordance with the following standard: ASTM D-4097: Contact Molded Glass Fiber Reinforced Chemical Resistant Tanks.
- 2.9 STEPS Steps shall be constructed according to ASTM D4101 of copolymer polypropylene, and be driven into preformed or pre-drilled holes after the concrete has cured, installed to conform to applicable sections of state, provincial and municipal building codes, highway, municipal or local specifications for the construction of such devices.
- 2.10 INSPECTION All precast concrete sections shall be inspected to ensure that dimensions, appearance and quality of the product meet local municipal specifications and ASTM C 478.

PART 3 – PERFORMANCE

3.1 GENERAL

- 3.1.1 Verification – The stormwater quality filter must be verified in accordance with ISO 14034:2016 Environmental management – Environmental technology verification (ETV).
- 3.1.2 Function - The stormwater quality filter treatment device shall function to remove pollutants by the following unit treatment processes; sedimentation, floatation, and membrane filtration.
- 3.1.3 Pollutants - The stormwater quality filter treatment device shall remove oil, debris, trash, coarse and fine particulates, particulate-bound pollutants, metals and nutrients from stormwater during runoff events.
- 3.1.4 Bypass - The stormwater quality filter treatment device shall typically utilize an external bypass to divert excessive flows. Internal bypass systems shall be equipped with a floatables baffle, and must avoid passage through the sump and/or cartridge filtration zone.
- 3.1.5 Treatment Flux Rate (Surface Loading Rate) – The stormwater quality filter treatment device shall treat 100% of the required water quality treatment flow based on a maximum design treatment flux rate (surface loading rate) across the membrane filter cartridges of 0.21 gpm/ft² (0.142 lps/m²).

3.2 FIELD TEST PERFORMANCE

At a minimum, the stormwater quality filter device shall have been field tested and verified with a minimum 25 TARP qualifying storm events and field monitoring shall have been conducted according to the TARP 2009 NJDEP TARP field test protocol, and have received NJCAT verification.

- 3.2.1 Suspended Solids Removal - The stormwater quality filter treatment device shall have demonstrated a minimum median TSS removal efficiency of 85% and a minimum median SSC removal efficiency of 95%.
- 3.2.2 Runoff Volume – The stormwater quality filter treatment device shall be engineered, designed, and sized to treat a minimum of 90 percent of the annual runoff volume determined from use of a minimum 15-year rainfall data set.
- 3.2.3 Fine Particle Removal - The stormwater quality filter treatment device shall have demonstrated the ability to capture fine particles as indicated by a minimum median removal efficiency of 75% for the particle fraction less than 25 microns, an effluent d_{50} of 15 microns or lower for all monitored storm events.
- 3.2.4 Turbidity Reduction - The stormwater quality filter treatment device shall have demonstrated the ability to reduce the turbidity from influent from a range of 5 to 171 NTU to an effluent turbidity of 15 NTU or lower.
- 3.2.5 Nutrient (Total Phosphorus & Total Nitrogen) Removal - The stormwater quality filter treatment device shall have demonstrated a minimum median Total Phosphorus removal of 55%, and a minimum median Total Nitrogen removal of 50%.
- 3.2.6 Metals (Total Zinc & Total Copper) Removal - The stormwater quality filter treatment device shall have demonstrated a minimum median Total Zinc removal of 55%, and a minimum median Total Copper removal of 85%.

3.3 INSPECTION and MAINTENANCE

The stormwater quality filter device shall have the following features:

- 3.3.1 Durability of membranes are subject to good handling practices during inspection and maintenance (removal, rinsing, and reinsertion) events, and site specific conditions that may have heavier or lighter loading onto the cartridges, and pollutant variability that may impact the membrane structural integrity. Membrane maintenance and replacement shall be in accordance with manufacturer's recommendations.
- 3.3.2 Inspection which includes trash and floatables collection, sediment depth determination, and visible determination of backwash pool depth shall be easily conducted from grade (outside the structure).
- 3.3.3 Manual rinsing of the reusable filter cartridges shall promote restoration of the flow capacity and sediment capacity of the filter cartridges, extending cartridge service life.

- 3.3.4 The filter device shall have a minimum 12 inches (305 mm) of sediment storage depth, and a minimum of 12 inches between the top of the sediment storage and bottom of the filter cartridge tentacles, unless otherwise specified by the design engineer. Variances may have an impact on the total performance and/or longevity between cartridge maintenance/replacement of the device.
- 3.3.5 Sediment removal from the filter treatment device shall be able to be conducted using a standard maintenance truck and vacuum apparatus, and a minimum one point of entry to the sump that is unobstructed by filter cartridges.
- 3.3.6 Maintenance access shall have a minimum clear height that provides suitable vertical clear space over all of the filter cartridges. Filter cartridges shall be able to be lifted straight vertically out of the receptacles and deck for the entire length of the cartridge.
- 3.3.7 Filter cartridges shall be able to be maintained without the requirement of additional lifting equipment.

PART 4 – EXECUTION

4.1 INSTALLATION

4.1.1 PRECAST DEVICE CONSTRUCTION SEQUENCE

The installation of a watertight precast concrete device should conform to ASTM C 891 and to any state highway, municipal or local specifications for the construction of manholes, whichever is more stringent. Selected sections of a general specification that are applicable are summarized below.

4.1.1.1 The watertight precast concrete device is installed in sections in the following sequence:

- aggregate base
- base slab
- treatment chamber and cartridge deck riser section(s)
- bypass section
- connect inlet and outlet pipes
- concrete riser section(s) and/or transition slab (if required)
- maintenance riser section(s) (if required)
- frame and access cover

4.1.2 The precast base should be placed level at the specified grade. The entire base should be in contact with the underlying compacted granular material. Subsequent sections, complete with joint seals, should be installed in accordance with the precast concrete manufacturer's recommendations.

4.1.3 Adjustment of the stormwater quality treatment device can be performed by lifting the upper sections free of the excavated area, re-leveling the base, and re-installing the sections. Damaged sections and gaskets should be repaired or replaced as necessary to restore original condition and watertight seals. Once the stormwater quality treatment device has been constructed, any/all lift holes must be plugged watertight with mortar or non-shrink grout.

- 4.1.4 Inlet and Outlet Pipes Inlet and outlet pipes should be securely set into the device using approved pipe seals (flexible boot connections, where applicable) so that the structure is watertight, and such that any pipe intrusion into the device does not impact the device functionality.
- 4.1.5 Frame and Cover Installation Adjustment units (e.g. grade rings) should be installed to set the frame and cover at the required elevation. The adjustment units should be laid in a full bed of mortar with successive units being joined using sealant recommended by the manufacturer. Frames for the cover should be set in a full bed of mortar at the elevation specified.

4.2 MAINTENANCE ACCESS WALL

In some instances the Maintenance Access Wall, if provided, shall require an extension attachment and sealing to the precast wall and cartridge deck at the job site, rather than at the precast facility. In this instance, installation of these components shall be performed according to instructions provided by the manufacturer.

4.3 FILTER CARTRIDGE INSTALLATION Filter cartridges shall be installed in the cartridge deck only after the construction site is fully stabilized and in accordance with the manufacturer's guidelines and recommendations. Contractor to contact the manufacturer to schedule cartridge delivery and review procedures/requirements to be completed to the device prior to installation of the cartridges and activation of the system.

PART 5 – QUALITY ASSURANCE

5.1 FILTER CARTRIDGE INSTALLATION Manufacturer shall coordinate delivery of filter cartridges and other internal components with contractor. Filter cartridges shall be delivered and installed complete after site is stabilized and unit is ready to accept cartridges. Unit is ready to accept cartridges after it has been cleaned out and any standing water, debris, and other materials have been removed. Contractor shall take appropriate action to protect the filter cartridge receptacles and filter cartridges from damage during construction, and in accordance with the manufacturer's recommendations and guidance. For systems with cartridges installed prior to full site stabilization and prior to system activation, the contractor can plug inlet and outlet pipes to prevent stormwater and other influent from entering the device. Plugs must be removed during the activation process.

5.2 INSPECTION AND MAINTENANCE

5.2.1 The manufacturer shall provide an Owner's Manual upon request.

5.2.2 After construction and installation, and during operation, the device shall be inspected and cleaned as necessary based on the manufacturer's recommended inspection and maintenance guidelines and the local regulatory agency/body.

5.3 REPLACEMENT FILTER CARTRIDGES When replacement membrane filter elements and/or other parts are required, only membrane filter elements and parts approved by the manufacturer for use with the stormwater quality filter device shall be installed.

END OF SECTION

DRAWING NOT TO BE USED FOR CONSTRUCTION

GENERAL NOTES:

- ALL DIMENSIONS INDICATED ARE IN MILLIMETERS (INCHES) UNLESS OTHERWISE SPECIFIED.
- JELLYFISH STRUCTURE INLET AND OUTLET PIPE SIZE AND ORIENTATION SHOWN FOR INFORMATIONAL PURPOSES ONLY.
- UNLESS OTHERWISE NOTED, BYPASS INFRASTRUCTURE, SUCH AS ALL UPSTREAM DIVERSION STRUCTURES, CONNECTING STRUCTURES, OR PIPE CONDUITS CONNECTING TO COMPLETE THE JELLYFISH SYSTEM SHALL BE PROVIDED AND ADDRESSED SEPARATELY.
- DRAWING FOR INFORMATIONAL PURPOSES ONLY. REFER TO ENGINEER'S SITE/UTILITY PLAN FOR STRUCTURE ORIENTATION.
- NO PRODUCT SUBSTITUTIONS SHALL BE ACCEPTED UNLESS SUBMITTED 10 DAYS PRIOR TO PROJECT BID DATE, OR AS DIRECTED BY THE ENGINEER OF RECORD.

JELLYFISH STRUCTURE & DESIGN NOTES:

- 457 MM Ø (18") MAINTENANCE ACCESS WALL TO BE USED FOR CLEANOUT AND ACCESS BELOW CARTRIDGE DECK.
- CASTINGS OR DOORS OF THE JELLYFISH MANHOLE STRUCTURE TO EXTEND TO DESIGN FINISH GRADE. DEPTHS IN EXCESS OF 3.65 M (12') MAY REQUIRE THE DESIGN AND INSTALLATION OF INTERMEDIATE SAFETY GRATES OR OTHER STRUCTURAL ELEMENTS.
- CASTINGS AND GRADE RINGS, OR DOORS AND DOOR RISERS, OR BOTH, SHALL BE GROUTED FOR WATERTIGHTNESS. STRUCTURE SHALL MEET AASHTO HS-20, ASSUMING EARTH COVER OF 0' - 3', AND GROUNDWATER ELEVATION AT, OR BELOW, THE OUTLET PIPE INVERT ELEVATION. ENGINEER OF RECORD TO CONFIRM ACTUAL GROUNDWATER ELEVATION. CASTINGS SHALL MEET AASHTO M306 LOAD RATING AND BE CAST WITH THE IMBRIUM LOGO.
- ALL STRUCTURAL SECTIONS AND PARTS TO MEET OR EXCEED ASTM C-478, ASTM C-443, AND ASTM D-4097 CORRESPONDING TO AASHTO SPECIFICATIONS, AND ANY OTHER SITE OR LOCAL STANDARDS.
- CONCRETE RISER SECTIONS FROM BOTTOM TO TOP WILL BE ADDED AS REQUIRED INCLUDING TRANSITION PIECES TO SMALLER DIAMETER RISERS FOR SURFACE ACCESSES WHERE WARRANTED BY SERVICING DEPTH.
- IF MINIMUM DEPTH FROM TOP OF CARTRIDGE DECK TO BOTTOM OF STRUCTURAL TOP SLAB CANNOT BE ACHIEVED DUE TO PIPING INVERT ELEVATIONS OR OTHER SITE CONSTRAINTS. ALTERNATIVE HATCH CONFIGURATIONS MAY BE AVAILABLE. HATCH DOORS SHOULD BE SIZED TO PROVIDE FULL ACCESS ABOVE THE CARTRIDGES TO ACCOMMODATE MAINTENANCE.
- STEPS TO BE APPROXIMATELY 330 MM (13") APART AND DIMENSIONS MUST MEET LOCAL STANDARDS. STEPS MUST BE INSTALLED AFTER CARTRIDGE DECK IS IN PLACE.
- CONFIGURATION OF INLET AND OUTLET PIPE CAN VARY TO MEET SITE'S NEEDS.
- IT IS THE RESPONSIBILITY OF OTHERS TO PROPERLY PROTECT THE TREATMENT DEVICE, AND KEEP THE DEVICE OFFLINE DURING CONSTRUCTION. FILTER CARTRIDGES SHALL NOT BE INSTALLED UNTIL THE PROJECT SITE IS CLEAN AND FREE OF DEBRIS, BY OTHERS. THE PROJECT SITE INCLUDES ANY SURFACE THAT CONTRIBUTES STORM DRAINAGE TO THE TREATMENT DEVICE. CARTRIDGES SHALL BE FURNISHED NEW, AT THE TIME OF FINAL ACCEPTANCE.
- THIS DRAWING MUST BE VIEWED IN CONJUNCTION WITH THE STANDARD JELLYFISH SPECIFICATION, AND STORMWATER QUALITY FILTER TREATMENT JELLYFISH DOCUMENTS.

INSTALLATION NOTES

- ANY SUB-BASE, BACKFILL DEPTH, AND/OR ANTI-FLOTATION PROVISIONS ARE SITE-SPECIFIC DESIGN CONSIDERATIONS AND SHALL BE SPECIFIED BY ENGINEER OF RECORD.
- CONTRACTOR TO PROVIDE EQUIPMENT WITH SUFFICIENT LIFTING AND REACH CAPACITY TO LIFT AND SET THE STRUCTURE (LIFTING CLUTCHES PROVIDED)
- CONTRACTOR WILL INSTALL AND LEVEL THE STRUCTURE, SEALING THE JOINTS, LINE ENTRY AND EXIT POINTS (NON-SHRINK GROUT WITH APPROVED WATERSTOP OR FLEXIBLE BOOT)
- CONTRACTOR TO TAKE APPROPRIATE MEASURES TO PROTECT CARTRIDGES FROM CONSTRUCTION-RELATED EROSION RUNOFF.
- CARTRIDGE INSTALLATION, BY IMBRIUM, SHALL OCCUR ONLY AFTER SITE HAS BEEN STABILIZED AND THE JELLYFISH UNIT IS CLEAN AND FREE OF DEBRIS. CONTACT IMBRIUM TO COORDINATE CARTRIDGE INSTALLATION WITH SITE STABILIZATION.

STANDARD OFFLINE JELLYFISH RECOMMENDED PIPE DIAMETERS			
MODEL DIAMETER (m)	MINIMUM ANGLE INLET/OUTLET PIPES	MINIMUM INLET PIPE DIAMETER (mm)	MINIMUM OUTLET PIPE DIAMETER (mm)
1.2	62	150	200
1.8	59	200	250
2.4	52	250	300
3.0	48	300	450
3.6	40	300	450

CONTACT IMBRIUM SYSTEMS FOR ALTERNATE PIPE DIAMETERS

FOR SITE SPECIFIC DRAWINGS PLEASE CONTACT YOUR LOCAL JELLYFISH FILTER REPRESENTATIVE. SITE SPECIFIC DRAWINGS ARE BASED ON THE BEST AVAILABLE INFORMATION AT THE TIME. SOME FIELD REVISIONS TO THE SYSTEM LOCATION OR CONNECTION PIPING MAY BE NECESSARY BASED ON AVAILABLE SPACE OR SITE CONFIGURATION REVISIONS. ELEVATIONS SHOULD BE MAINTAINED EXCEPT WHERE NOTED ON BYPASS STRUCTURE.

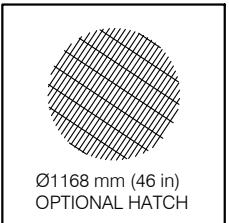
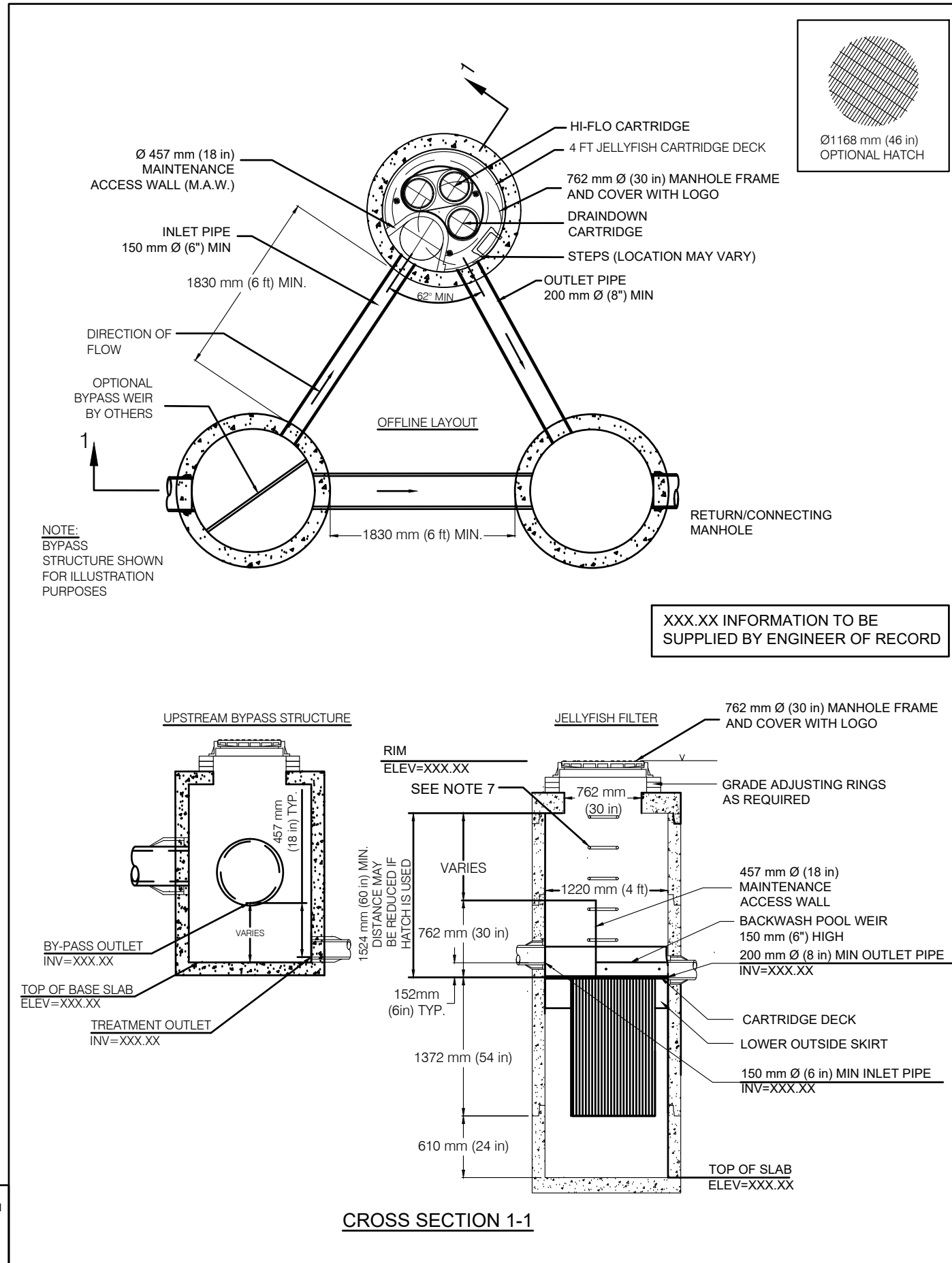

XXX.XX INFORMATION TO BE SUPPLIED BY ENGINEER OF RECORD

JELLYFISH DESIGN NOTES

JELLYFISH TREATMENT CAPACITY IS A FUNCTION OF THE CARTRIDGE SELECTION AND THE NUMBER OF CARTRIDGES. THE STANDARD MANHOLE STYLE IS SHOWN. Ø1220 mm (48") MANHOLE JELLYFISH PEAK TREATMENT CAPACITY IS 12.7 L/s (0.54 CFS). TREATMENT FLOW RATE IS BASED ON 457 mm (18") OF HEAD PRESSURE.

CARTRIDGE SELECTION	CARTRIDGE DEPTH	OUTLET INVERT TO STRUCTURE BASE SLAB	RETURN PERIOD OF PEAK FLOW (yrs)	# OF CARTRIDGES REQUIRED (HF / DD)
54"	90"	5.09 / 2.65	57 / 28	1
40"	76"	3.68 / 1.84	42 / 21	2
27"	63"	2.55 / 1.27	28 / 14	4
15"	51"	1.41 / 0.71	16 / 8	8
MAX. SEDIMENT CAPACITY (kg)				142
MAX. TREATMENT (L/s)				12.7
MAX. CARTS HIGH-FLO/DRAINDOWN				2 / 1
MAX. SEDIMENT CAPACITY (kg)				105
MAX. TREATMENT (L/s)				9.3
MAX. CARTS HIGH-FLO/DRAINDOWN				70
MAX. SEDIMENT CAPACITY (kg)				6.2
MAX. TREATMENT (L/s)				3.4

SITE SPECIFIC DATA REQUIREMENTS

JELLYFISH MODEL	*
STRUCTURE ID	*
WATER QUALITY FLOW RATE (L/s)	*
PEAK FLOW RATE (L/s)	*
RETURN PERIOD OF PEAK FLOW (yrs)	*
# OF CARTRIDGES REQUIRED (HF / DD)	*
CARTRIDGE SIZE (inches)	*
PIPE DATA:	I.E. MAT'L DIA SLOPE % HGL
INLET #1	* * * * *
INLET #2	* * * * *
OUTLET	* * * * *

* PER ENGINEER OF RECORD

JF4 STANDARD
Scale = 1:50

7037 Ridge Road, Suite 350, Hanover, MD 21076
USA 888-279-8826 CA 800-955-4801 INTL +1-415-960-9900

THIS PRODUCT MAY BE PROTECTED BY ONE OR MORE OF THE FOLLOWING PATENTS: U.S. PAT. NO. 8,287,796; U.S. PAT. NO. 8,121,818; U.S. PAT. NO. 8,027,263; U.S. PAT. NO. 8,027,264; U.S. PAT. NO. 8,027,265; U.S. PAT. NO. 8,027,266; U.S. PAT. NO. 8,027,267; U.S. PAT. NO. 8,027,268; U.S. PAT. NO. 8,027,269; U.S. PAT. NO. 8,027,270; U.S. PAT. NO. 8,027,271; U.S. PAT. NO. 8,027,272; U.S. PAT. NO. 8,027,273; U.S. PAT. NO. 8,027,274; U.S. PAT. NO. 8,027,275; U.S. PAT. NO. 8,027,276; U.S. PAT. NO. 8,027,277; U.S. PAT. NO. 8,027,278; U.S. PAT. NO. 8,027,279; U.S. PAT. NO. 8,027,280; U.S. PAT. NO. 8,027,281; U.S. PAT. NO. 8,027,282; U.S. PAT. NO. 8,027,283; U.S. PAT. NO. 8,027,284; U.S. PAT. NO. 8,027,285; U.S. PAT. NO. 8,027,286; U.S. PAT. NO. 8,027,287; U.S. PAT. NO. 8,027,288; U.S. PAT. NO. 8,027,289; U.S. PAT. NO. 8,027,290; U.S. PAT. NO. 8,027,291; U.S. PAT. NO. 8,027,292; U.S. PAT. NO. 8,027,293; U.S. PAT. NO. 8,027,294; U.S. PAT. NO. 8,027,295; U.S. PAT. NO. 8,027,296; U.S. PAT. NO. 8,027,297; U.S. PAT. NO. 8,027,298; U.S. PAT. NO. 8,027,299; U.S. PAT. NO. 8,027,300; U.S. PAT. NO. 8,027,301; U.S. PAT. NO. 8,027,302; U.S. PAT. NO. 8,027,303; U.S. PAT. NO. 8,027,304; U.S. PAT. NO. 8,027,305; U.S. PAT. NO. 8,027,306; U.S. PAT. NO. 8,027,307; U.S. PAT. NO. 8,027,308; U.S. PAT. NO. 8,027,309; U.S. PAT. NO. 8,027,310; U.S. PAT. NO. 8,027,311; U.S. PAT. NO. 8,027,312; U.S. PAT. NO. 8,027,313; U.S. PAT. NO. 8,027,314; U.S. PAT. NO. 8,027,315; U.S. PAT. NO. 8,027,316; U.S. PAT. NO. 8,027,317; U.S. PAT. NO. 8,027,318; U.S. PAT. NO. 8,027,319; U.S. PAT. NO. 8,027,320; U.S. PAT. NO. 8,027,321; U.S. PAT. NO. 8,027,322; U.S. PAT. NO. 8,027,323; U.S. PAT. NO. 8,027,324; U.S. PAT. NO. 8,027,325; U.S. PAT. NO. 8,027,326; U.S. PAT. NO. 8,027,327; U.S. PAT. NO. 8,027,328; U.S. PAT. NO. 8,027,329; U.S. PAT. NO. 8,027,330; U.S. PAT. NO. 8,027,331; U.S. PAT. NO. 8,027,332; U.S. PAT. NO. 8,027,333; U.S. PAT. NO. 8,027,334; U.S. PAT. NO. 8,027,335; U.S. PAT. NO. 8,027,336; U.S. PAT. NO. 8,027,337; U.S. PAT. NO. 8,027,338; U.S. PAT. NO. 8,027,339; U.S. PAT. NO. 8,027,340; U.S. PAT. NO. 8,027,341; U.S. PAT. NO. 8,027,342; U.S. PAT. NO. 8,027,343; U.S. PAT. NO. 8,027,344; U.S. PAT. NO. 8,027,345; U.S. PAT. NO. 8,027,346; U.S. PAT. NO. 8,027,347; U.S. PAT. NO. 8,027,348; U.S. PAT. NO. 8,027,349; U.S. PAT. NO. 8,027,350; U.S. PAT. NO. 8,027,351; U.S. PAT. NO. 8,027,352; U.S. PAT. NO. 8,027,353; U.S. PAT. NO. 8,027,354; U.S. PAT. NO. 8,027,355; U.S. PAT. NO. 8,027,356; U.S. PAT. NO. 8,027,357; U.S. PAT. NO. 8,027,358; U.S. PAT. NO. 8,027,359; U.S. PAT. NO. 8,027,360; U.S. PAT. NO. 8,027,361; U.S. PAT. NO. 8,027,362; U.S. PAT. NO. 8,027,363; U.S. PAT. NO. 8,027,364; U.S. PAT. NO. 8,027,365; U.S. PAT. NO. 8,027,366; U.S. PAT. NO. 8,027,367; U.S. PAT. NO. 8,027,368; U.S. PAT. NO. 8,027,369; U.S. PAT. NO. 8,027,370; U.S. PAT. NO. 8,027,371; U.S. PAT. NO. 8,027,372; U.S. PAT. NO. 8,027,373; U.S. PAT. NO. 8,027,374; U.S. PAT. NO. 8,027,375; U.S. PAT. NO. 8,027,376; U.S. PAT. NO. 8,027,377; U.S. PAT. NO. 8,027,378; U.S. PAT. NO. 8,027,379; U.S. PAT. NO. 8,027,380; U.S. PAT. NO. 8,027,381; U.S. PAT. NO. 8,027,382; U.S. PAT. NO. 8,027,383; U.S. PAT. NO. 8,027,384; U.S. PAT. NO. 8,027,385; U.S. PAT. NO. 8,027,386; U.S. PAT. NO. 8,027,387; U.S. PAT. NO. 8,027,388; U.S. PAT. NO. 8,027,389; U.S. PAT. NO. 8,027,390; U.S. PAT. NO. 8,027,391; U.S. PAT. NO. 8,027,392; U.S. PAT. NO. 8,027,393; U.S. PAT. NO. 8,027,394; U.S. PAT. NO. 8,027,395; U.S. PAT. NO. 8,027,396; U.S. PAT. NO. 8,027,397; U.S. PAT. NO. 8,027,398; U.S. PAT. NO. 8,027,399; U.S. PAT. NO. 8,027,400; U.S. PAT. NO. 8,027,401; U.S. PAT. NO. 8,027,402; U.S. PAT. NO. 8,027,403; U.S. PAT. NO. 8,027,404; U.S. PAT. NO. 8,027,405; U.S. PAT. NO. 8,027,406; U.S. PAT. NO. 8,027,407; U.S. PAT. NO. 8,027,408; U.S. PAT. NO. 8,027,409; U.S. PAT. NO. 8,027,410; U.S. PAT. NO. 8,027,411; U.S. PAT. NO. 8,027,412; U.S. PAT. NO. 8,027,413; U.S. PAT. NO. 8,027,414; U.S. PAT. NO. 8,027,415; U.S. PAT. NO. 8,027,416; U.S. PAT. NO. 8,027,417; U.S. PAT. NO. 8,027,418; U.S. PAT. NO. 8,027,419; U.S. PAT. NO. 8,027,420; U.S. PAT. NO. 8,027,421; U.S. PAT. NO. 8,027,422; U.S. PAT. NO. 8,027,423; U.S. PAT. NO. 8,027,424; U.S. PAT. NO. 8,027,425; U.S. PAT. NO. 8,027,426; U.S. PAT. NO. 8,027,427; U.S. PAT. NO. 8,027,428; U.S. PAT. NO. 8,027,429; U.S. PAT. NO. 8,027,430; U.S. PAT. NO. 8,027,431; U.S. PAT. NO. 8,027,432; U.S. PAT. NO. 8,027,433; U.S. PAT. NO. 8,027,434; U.S. PAT. NO. 8,027,435; U.S. PAT. NO. 8,027,436; U.S. PAT. NO. 8,027,437; U.S. PAT. NO. 8,027,438; U.S. PAT. NO. 8,027,439; U.S. PAT. NO. 8,027,440; U.S. PAT. NO. 8,027,441; U.S. PAT. NO. 8,027,442; U.S. PAT. NO. 8,027,443; U.S. PAT. NO. 8,027,444; U.S. PAT. NO. 8,027,445; U.S. PAT. NO. 8,027,446; U.S. PAT. NO. 8,027,447; U.S. PAT. NO. 8,027,448; U.S. PAT. NO. 8,027,449; U.S. PAT. NO. 8,027,450; U.S. PAT. NO. 8,027,451; U.S. PAT. NO. 8,027,452; U.S. PAT. NO. 8,027,453; U.S. PAT. NO. 8,027,454; U.S. PAT. NO. 8,027,455; U.S. PAT. NO. 8,027,456; U.S. PAT. NO. 8,027,457; U.S. PAT. NO. 8,027,458; U.S. PAT. NO. 8,027,459; U.S. PAT. NO. 8,027,460; U.S. PAT. NO. 8,027,461; U.S. PAT. NO. 8,027,462; U.S. PAT. NO. 8,027,463; U.S. PAT. NO. 8,027,464; U.S. PAT. NO. 8,027,465; U.S. PAT. NO. 8,027,466; U.S. PAT. NO. 8,027,467; U.S. PAT. NO. 8,027,468; U.S. PAT. NO. 8,027,469; U.S. PAT. NO. 8,027,470; U.S. PAT. NO. 8,027,471; U.S. PAT. NO. 8,027,472; U.S. PAT. NO. 8,027,473; U.S. PAT. NO. 8,027,474; U.S. PAT. NO. 8,027,475; U.S. PAT. NO. 8,027,476; U.S. PAT. NO. 8,027,477; U.S. PAT. NO. 8,027,478; U.S. PAT. NO. 8,027,479; U.S. PAT. NO. 8,027,480; U.S. PAT. NO. 8,027,481; U.S. PAT. NO. 8,027,482; U.S. PAT. NO. 8,027,483; U.S. PAT. NO. 8,027,484; U.S. PAT. NO. 8,027,485; U.S. PAT. NO. 8,027,486; U.S. PAT. NO. 8,027,487; U.S. PAT. NO. 8,027,488; U.S. PAT. NO. 8,027,489; U.S. PAT. NO. 8,027,490; U.S. PAT. NO. 8,027,491; U.S. PAT. NO. 8,027,492; U.S. PAT. NO. 8,027,493; U.S. PAT. NO. 8,027,494; U.S. PAT. NO. 8,027,495; U.S. PAT. NO. 8,027,496; U.S. PAT. NO. 8,027,497; U.S. PAT. NO. 8,027,498; U.S. PAT. NO. 8,027,499; U.S. PAT. NO. 8,027,500; U.S. PAT. NO. 8,027,501; U.S. PAT. NO. 8,027,502; U.S. PAT. NO. 8,027,503; U.S. PAT. NO. 8,027,504; U.S. PAT. NO. 8,027,505; U.S. PAT. NO. 8,027,506; U.S. PAT. NO. 8,027,507; U.S. PAT. NO. 8,027,508; U.S. PAT. NO. 8,027,509; U.S. PAT. NO. 8,027,510; U.S. PAT. NO. 8,027,511; U.S. PAT. NO. 8,027,512; U.S. PAT. NO. 8,027,513; U.S. PAT. NO. 8,027,514; U.S. PAT. NO. 8,027,515; U.S. PAT. NO. 8,027,516; U.S. PAT. NO. 8,027,517; U.S. PAT. NO. 8,027,518; U.S. PAT. NO. 8,027,519; U.S. PAT. NO. 8,027,520; U.S. PAT. NO. 8,027,521; U.S. PAT. NO. 8,027,522; U.S. PAT. NO. 8,027,523; U.S. PAT. NO. 8,027,524; U.S. PAT. NO. 8,027,525; U.S. PAT. NO. 8,027,526; U.S. PAT. NO. 8,027,527; U.S. PAT. NO. 8,027,528; U.S. PAT. NO. 8,027,529; U.S. PAT. NO. 8,027,530; U.S. PAT. NO. 8,027,531; U.S. PAT. NO. 8,027,532; U.S. PAT. NO. 8,027,533; U.S. PAT. NO. 8,027,534; U.S. PAT. NO. 8,027,535; U.S. PAT. NO. 8,027,536; U.S. PAT. NO. 8,027,537; U.S. PAT. NO. 8,027,538; U.S. PAT. NO. 8,027,539; U.S. PAT. NO. 8,027,540; U.S. PAT. NO. 8,027,541; U.S. PAT. NO. 8,027,542; U.S. PAT. NO. 8,027,543; U.S. PAT. NO. 8,027,544; U.S. PAT. NO. 8,027,545; U.S. PAT. NO. 8,027,546; U.S. PAT. NO. 8,027,547; U.S. PAT. NO. 8,027,548; U.S. PAT. NO. 8,027,549; U.S. PAT. NO. 8,027,550; U.S. PAT. NO. 8,027,551; U.S. PAT. NO. 8,027,552; U.S. PAT. NO. 8,027,553; U.S. PAT. NO. 8,027,554; U.S. PAT. NO. 8,027,555; U.S. PAT. NO. 8,027,556; U.S. PAT. NO. 8,027,557; U.S. PAT. NO. 8,027,558; U.S. PAT. NO. 8,027,559; U.S. PAT. NO. 8,027,560; U.S. PAT. NO. 8,027,561; U.S. PAT. NO. 8,027,562; U.S. PAT. NO. 8,027,563; U.S. PAT. NO. 8,027,564; U.S. PAT. NO. 8,027,565; U.S. PAT. NO. 8,027,566; U.S. PAT. NO. 8,027,567; U.S. PAT. NO. 8,027,568; U.S. PAT. NO. 8,027,569; U.S. PAT. NO. 8,027,570; U.S. PAT. NO. 8,027,571; U.S. PAT. NO. 8,027,572; U.S. PAT. NO. 8,027,573; U.S. PAT. NO. 8,027,574; U.S. PAT. NO. 8,027,575; U.S. PAT. NO. 8,027,576; U.S. PAT. NO. 8,027,577; U.S. PAT. NO. 8,027,578; U.S. PAT. NO. 8,027,579; U.S. PAT. NO. 8,027,580; U.S. PAT. NO. 8,027,581; U.S. PAT. NO. 8,027,582; U.S. PAT. NO. 8,027,583; U.S. PAT. NO. 8,027,584; U.S. PAT. NO. 8,027,585; U.S. PAT. NO. 8,027,586; U.S. PAT. NO. 8,027,587; U.S. PAT. NO. 8,027,588; U.S. PAT. NO. 8,027,589; U.S. PAT. NO. 8,027,590; U.S. PAT. NO. 8,027,591; U.S. PAT. NO. 8,027,592; U.S. PAT. NO. 8,027,593; U.S. PAT. NO. 8,027,594; U.S. PAT. NO. 8,027,595; U.S. PAT. NO. 8,027,596; U.S. PAT. NO. 8,027,597; U.S. PAT. NO. 8,027,598; U.S. PAT. NO. 8,027,599; U.S. PAT. NO. 8,027,600; U.S. PAT. NO. 8,027,601; U.S. PAT. NO. 8,027,602; U.S. PAT. NO. 8,027,603; U.S. PAT. NO. 8,027,604; U.S. PAT. NO. 8,027,605; U.S. PAT. NO. 8,027,606; U.S. PAT. NO. 8,027,607; U.S. PAT. NO. 8,027,608; U.S. PAT. NO. 8,027,609; U.S. PAT. NO. 8,027,610; U.S. PAT. NO. 8,027,611; U.S. PAT. NO. 8,027,612; U.S. PAT. NO. 8,027,613; U.S. PAT. NO. 8,027,614; U.S. PAT. NO. 8,027,615; U.S. PAT. NO. 8,027,616; U.S. PAT. NO. 8,027,617; U.S. PAT. NO. 8,027,618; U.S. PAT. NO. 8,027,619; U.S. PAT. NO. 8,027,620; U.S. PAT. NO. 8,027,621; U.S. PAT. NO. 8,027,622; U.S. PAT. NO. 8,027,623; U.S. PAT. NO. 8,027,624; U.S. PAT. NO. 8,027,625; U.S. PAT. NO. 8,027,626; U.S. PAT. NO. 8,027,627; U.S. PAT. NO. 8,027,628; U.S. PAT. NO. 8,027,629; U.S. PAT. NO. 8,027,630; U.S. PAT. NO. 8,027,631; U.S. PAT. NO. 8,027,632; U.S. PAT. NO. 8,027,633; U.S. PAT. NO. 8,027,634; U.S. PAT. NO. 8,027,635; U.S. PAT. NO. 8,027,636; U.S. PAT. NO. 8,027,637; U.S. PAT. NO. 8,027,638; U.S. PAT. NO. 8,027,639; U.S. PAT. NO. 8,027,640; U.S. PAT. NO. 8,027,641; U.S. PAT. NO. 8,027,642; U.S. PAT. NO. 8,027,643; U.S. PAT. NO. 8,027,644; U.S. PAT. NO. 8,027,645; U.S. PAT. NO. 8,027,646; U.S. PAT. NO. 8,027,647; U.S. PAT. NO. 8,027,648; U.S. PAT. NO. 8,027,649; U.S. PAT. NO. 8,027,650; U.S. PAT. NO. 8,027,651; U.S. PAT. NO. 8,027,652; U.S. PAT. NO. 8,027,653; U.S. PAT. NO. 8,027,654; U.S. PAT. NO. 8,027,655; U.S. PAT. NO. 8,027,656; U.S. PAT. NO. 8,027,657; U.S. PAT. NO. 8,027,658; U.S. PAT. NO. 8,027,659; U.S. PAT. NO. 8,027,660; U.S. PAT. NO. 8,027,661; U.S. PAT. NO. 8,027,662; U.S. PAT. NO. 8,027,663; U.S. PAT. NO. 8,027,664; U.S. PAT. NO. 8,027,665; U.S. PAT. NO. 8,027,666; U.S. PAT. NO. 8,027,667; U.S. PAT. NO. 8,027,668; U.S. PAT. NO. 8,027,669; U.S. PAT. NO. 8,027,670; U.S. PAT. NO. 8,027,671; U.S. PAT. NO. 8,027,672; U.S. PAT. NO. 8,027,673; U.S. PAT. NO. 8,027,674; U.S. PAT. NO. 8,027,675; U.S. PAT. NO. 8,027,676; U.S. PAT. NO. 8,027,677; U.S. PAT. NO. 8,027,678; U.S. PAT. NO. 8,027,679; U.S. PAT. NO. 8,027,680; U.S. PAT. NO. 8,027,681; U.S. PAT. NO. 8,027,682; U.S. PAT. NO. 8,027,683; U.S. PAT. NO. 8,027,684; U.S. PAT. NO. 8,027,685; U.S. PAT. NO. 8,027,686; U.S. PAT. NO. 8,027,687; U.S. PAT. NO. 8,027,688; U.S. PAT. NO. 8,027,689; U.S. PAT. NO. 8,027,690; U.S. PAT. NO. 8,027,691; U.S. PAT. NO. 8,027,692; U.S. PAT. NO. 8,027,693; U.S. PAT. NO. 8,027,694; U.S. PAT. NO. 8,027,695; U.S. PAT. NO. 8,027,696; U.S. PAT. NO. 8,027,697; U.S. PAT. NO. 8,027,698; U.S. PAT. NO. 8,027,699; U.S. PAT. NO. 8,027,700; U.S. PAT. NO. 8,027,701; U.S. PAT. NO. 8,027,702; U.S. PAT. NO. 8,027,703; U.S. PAT. NO. 8,027,704; U.S. PAT. NO. 8,027,705; U.S. PAT. NO. 8,027,706; U.S. PAT. NO. 8,027,707; U.S. PAT. NO. 8,027,708; U.S. PAT. NO. 8,027,709; U.S. PAT. NO. 8,027,710; U.S. PAT. NO. 8,027,711; U.S. PAT. NO. 8,027,712; U.S. PAT. NO. 8,027,713; U.S. PAT. NO. 8,027,714; U.S. PAT. NO. 8,027,715; U.S. PAT. NO. 8,027,716; U.S. PAT. NO. 8,027,717; U.S. PAT. NO. 8,027,718; U.S. PAT. NO. 8,027,719; U.S. PAT. NO. 8,027,720; U.S. PAT. NO. 8,027,721; U.S. PAT. NO. 8,027,722; U.S. PAT. NO. 8,027,723; U.S. PAT. NO. 8,027,724; U.S. PAT. NO. 8,027,725; U.S. PAT. NO. 8,027,726; U.S. PAT. NO. 8,027,727; U.S. PAT. NO. 8,027,728; U.S. PAT. NO. 8,027,729; U.S. PAT. NO. 8,027,730; U.S. PAT. NO. 8,027,731; U.S. PAT. NO. 8,027,732; U.S. PAT. NO. 8,027,733; U.S. PAT. NO. 8,027,734; U.S. PAT. NO. 8,027,735; U.S. PAT. NO. 8,027,736; U.S. PAT. NO. 8,027,737; U.S. PAT. NO. 8,027,738; U.S. PAT. NO. 8,027,739; U.S. PAT. NO. 8,027,740; U.S. PAT. NO. 8,027,741; U.S. PAT. NO. 8,027,742; U.S. PAT. NO. 8,027,743; U.S. PAT. NO. 8,027,744; U.S. PAT. NO. 8,027,745; U.S. PAT. NO. 8,027,746; U.S. PAT. NO. 8,027,747; U.S. PAT. NO. 8,027,748;

JELLYFISH® FILTER - SPECIFICATIONS

GENERAL

- A. **WORK INCLUDED:** SPECIFIES REQUIREMENTS FOR CONSTRUCTION AND PERFORMANCE OF AN UNDERGROUND STORMWATER QUALITY, MEMBRANE FILTRATION, AND TREATMENT DEVICE THAT REMOVES POLLUTANTS FROM STORMWATER RUNOFF THROUGH THE UNIT OPERATIONS OF SEDIMENTATION, FLOATATION, AND MEMBRANE FILTRATION.
- B. **REFERENCE STANDARDS:**
 - ASTM C 891: SPECIFICATION FOR INSTALLATION OF UNDERGROUND PRECAST CONCRETE UTILITY STRUCTURES
 - ASTM C 478: SPECIFICATION FOR PRECAST REINFORCED CONCRETE MANHOLE SECTIONS
 - ASTM C 990: SPECIFICATION FOR JOINTS FOR CONCRETE MANHOLES USING PREFORMED FLEXIBLE JOINT SEALANTS
 - ASTM D 4101: SPECIFICATION FOR COPOLYMER STEPS CONSTRUCTION
- C. **SHOP DRAWINGS:** SHOP DRAWINGS FOR THE STRUCTURE AND PERFORMANCE ARE TO BE SUBMITTED WITH EACH ORDER TO THE CONTRACTOR. CONTRACTOR SHALL FORWARD SHOP DRAWING SUBMITTAL TO THE CONSULTING ENGINEER FOR APPROVAL. SHOP DRAWINGS ARE TO DETAIL THE STRUCTURE PRECAST CONCRETE AND CALL OUT OR NOTE THE FIBERGLASS (FRP) INTERNALS/COMPONENTS.
- D. **PRODUCT SUBSTITUTIONS:** NO PRODUCT SUBSTITUTIONS SHALL BE ACCEPTED UNLESS SUBMITTED 10 DAYS PRIOR TO PROJECT BID DATE, OR AS DIRECTED BY THE ENGINEER OF RECORD. SUBMISSIONS FOR SUBSTITUTIONS REQUIRE REVIEW AND APPROVAL BY THE ENGINEER OF RECORD, FOR HYDRAULIC PERFORMANCE, IMPACT TO PROJECT DESIGNS, EQUIVALENT TREATMENT PERFORMANCE, AND ANY REQUIRED PROJECT PLAN AND REPORT (HYDROLOGY/HYDRAULIC, WATER QUALITY, STORMWATER POLLUTION) MODIFICATIONS THAT WOULD BE REQUIRED BY THE APPROVING JURISDICTIONS/AGENCIES. CONTRACTOR TO COORDINATE WITH THE ENGINEER OF RECORD ANY APPLICABLE MODIFICATIONS TO THE PROJECT ESTIMATES OF COST, BONDING AMOUNT DETERMINATIONS, PLAN CHECK FEES FOR CHANGES TO APPROVED DOCUMENTS, AND/OR ANY OTHER REGULATORY REQUIREMENTS RESULTING FROM THE PRODUCT SUBSTITUTION.
- E. **HANDLING AND STORAGE:** PREVENT DAMAGE TO MATERIALS DURING STORAGE AND HANDLING.

PRODUCTS

- A. THE DEVICE SHALL BE A CYLINDRICAL OR RECTANGULAR, ALL CONCRETE STRUCTURE (INCLUDING RISERS), CONSTRUCTED FROM PRECAST CONCRETE RISER AND SLAB COMPONENTS OR MONOLITHIC PRECAST STRUCTURE(S), INSTALLED TO CONFORM TO ASTM C 891 AND TO ANY REQUIRED STATE HIGHWAY, MUNICIPAL OR LOCAL SPECIFICATIONS; WHICHEVER IS MORE STRINGENT. THE DEVICE SHALL BE WATERTIGHT.
- B. THE CYLINDRICAL CONCRETE DEVICE SHALL INCLUDE A FIBERGLASS CARTRIDGE DECK INSERT. THE RECTANGULAR CONCRETE DEVICE SHALL INCLUDE A COATED ALUMINUM INSERT. IN EITHER INSTANCE, THE INSERT SHALL BE BOLTED AND SEALED WATERTIGHT INSIDE THE PRECAST CONCRETE CHAMBER. THE INSERT SHALL SERVE AS: (A) A HORIZONTAL DIVIDER BETWEEN THE LOWER TREATMENT ZONE AND THE UPPER TREATED EFFLUENT ZONE; (B) A DECK FOR ATTACHMENT OF FILTER CARTRIDGES SUCH THAT THE MEMBRANE FILTER ELEMENTS OF EACH CARTRIDGE EXTEND INTO THE LOWER TREATMENT ZONE; (C) A PLATFORM FOR MAINTENANCE WORKERS TO SERVICE THE FILTER CARTRIDGES (MAXIMUM MANNED WEIGHT = 450 POUNDS); (D) A CONDUIT FOR CONVEYANCE OF TREATED WATER TO THE EFFLUENT PIPE.
- C. MEMBRANE FILTER CARTRIDGES SHALL BE COMPRISED OF REUSABLE CYLINDRICAL MEMBRANE FILTER ELEMENTS CONNECTED TO A PERFORATED HEAD PLATE. THE NUMBER OF MEMBRANE FILTER ELEMENTS PER CARTRIDGE SHALL BE A MINIMUM OF ELEVEN 2.75-INCH (70-MM) OR GREATER DIAMETER ELEMENTS. THE LENGTH OF EACH FILTER ELEMENT SHALL BE A MINIMUM 15 INCHES (381 MM). EACH CARTRIDGE SHALL BE FITTED INTO THE CARTRIDGE DECK BY INSERTION INTO A CARTRIDGE RECEPTACLE THAT IS PERMANENTLY MOUNTED INTO THE CARTRIDGE DECK. EACH CARTRIDGE SHALL BE SECURED BY A CARTRIDGE LID THAT IS THREADED ONTO THE RECEPTACLE, OR SIMILAR MECHANISM TO SECURE THE CARTRIDGE INTO THE DECK. THE MAXIMUM TREATMENT FLOW RATE OF A FILTER CARTRIDGE SHALL BE CONTROLLED BY AN ORIFICE IN THE CARTRIDGE LID, OR ON THE INDIVIDUAL CARTRIDGE ITSELF, AND BASED ON A DESIGN FLUX RATE (SURFACE LOADING RATE) DETERMINED BY THE MAXIMUM TREATMENT FLOW RATE PER UNIT OF FILTRATION MEMBRANE SURFACE AREA. THE MAXIMUM FLUX RATE SHALL BE 0.21 GPM/FT2 (0.142 LPS/M2). EACH MEMBRANE FILTER CARTRIDGE SHALL ALLOW FOR MANUAL INSTALLATION AND REMOVAL.
- D. ALL FILTER CARTRIDGES AND MEMBRANES SHALL BE REUSABLE AND ALLOW FOR THE USE OF FILTRATION MEMBRANE RINSING PROCEDURES TO RESTORE FLOW CAPACITY AND SEDIMENT CAPACITY; EXTENDING CARTRIDGE SERVICE LIFE.
- E. ACCESS SHALL HAVE A MINIMUM CLEAR HEIGHT OF 60" OVER ALL OF THE FILTER CARTRIDGES, OR BE ACCESSIBLE BY A HATCH OR OTHER MECHANISM THAT PROVIDES MINIMUM 60" VERTICAL CLEAR SPACE OVER ALL OF THE FILTER CARTRIDGES. FILTER CARTRIDGES SHALL BE ABLE TO BE LIFTED STRAIGHT VERTICALLY OUT OF THE RECEPTACLES AND DECK FOR THE ENTIRE LENGTH OF THE CARTRIDGE.
- F. THE DEVICE SHALL INCLUDE A MINIMUM 24 INCHES (610 MM) OF SUMP BELOW THE BOTTOM OF THE CARTRIDGES FOR SEDIMENT ACCUMULATION, UNLESS OTHERWISE SPECIFIED BY THE DESIGN ENGINEER. DEPTHS LESS THAN 24" MAY HAVE AN IMPACT ON THE TOTAL PERFORMANCE AND/OR LONGEVITY BETWEEN CARTRIDGE MAINTENANCE/REPLACEMENT OF THE DEVICE.
- G. ALL PRECAST CONCRETE COMPONENTS SHALL BE MANUFACTURED TO A MINIMUM LIVE LOAD OF HS-20 TRUCK LOADING OR GREATER BASED ON LOCAL REGULATORY SPECIFICATIONS, UNLESS OTHERWISE MODIFIED OR SPECIFIED BY THE DESIGN ENGINEER, AND SHALL BE WATERTIGHT.
- H. GASKETS AND/OR SEALANTS TO PROVIDE WATER TIGHT SEAL BETWEEN CONCRETE JOINTS. JOINTS SHALL BE SEALED WITH PREFORMED JOINT SEALING COMPOUND CONFORMING TO ASTM C 990.
- I. FRAME AND COVERS MUST BE MANUFACTURED FROM CAST-IRON OR OTHER COMPOSITE MATERIAL TESTED TO WITHSTAND H-20 OR GREATER DESIGN LOADS, AND AS APPROVED BY THE LOCAL REGULATORY BODY. FRAMES AND COVERS MUST BE EMBOSSED WITH THE NAME OF THE DEVICE MANUFACTURER OR THE DEVICE BRAND NAME.
- J. DOOR AND HATCHES, IF PROVIDED SHALL MEET DESIGNATED LOADING REQUIREMENTS OR AT A MINIMUM FOR INCIDENTAL VEHICULAR TRAFFIC.
- K. ALL CONCRETE COMPONENTS SHALL BE MANUFACTURED ACCORDING TO LOCAL SPECIFICATIONS AND SHALL MEET THE REQUIREMENTS OF ASTM C 478.
- L. THE FIBERGLASS PORTION OF THE FILTER DEVICE SHALL BE CONSTRUCTED IN ACCORDANCE WITH THE FOLLOWING STANDARD: ASTM D-4097: CONTACT MOLDED GLASS FIBER REINFORCED CHEMICAL RESISTANT TANKS.
- M. STEPS SHALL BE CONSTRUCTED ACCORDING TO ASTM D4101 OF COPOLYMER POLYPROPYLENE, AND BE DRIVEN INTO PREFORMED OR PRE-DRILLED HOLES AFTER THE CONCRETE HAS CURED, INSTALLED TO CONFORM TO APPLICABLE SECTIONS OF STATE, PROVINCIAL AND MUNICIPAL BUILDING CODES, HIGHWAY, MUNICIPAL OR LOCAL SPECIFICATIONS FOR THE CONSTRUCTION OF SUCH DEVICES.
- N. ALL PRECAST CONCRETE SECTIONS SHALL BE INSPECTED TO ENSURE THAT DIMENSIONS, APPEARANCE AND QUALITY OF THE PRODUCT MEET LOCAL MUNICIPAL SPECIFICATIONS AND ASTM C 478.

PERFORMANCE

- A. THE STORMWATER QUALITY FILTER TREATMENT DEVICE SHALL FUNCTION TO REMOVE POLLUTANTS BY THE FOLLOWING UNIT TREATMENT PROCESSES; SEDIMENTATION, FLOATATION, AND MEMBRANE FILTRATION.
- B. THE STORMWATER QUALITY FILTER TREATMENT DEVICE SHALL REMOVE OIL, DEBRIS, TRASH, COARSE AND FINE PARTICULATES, PARTICULATE-BOUND POLLUTANTS, METALS AND NUTRIENTS FROM STORMWATER DURING RUNOFF EVENTS.
- C. THE STORMWATER QUALITY FILTER TREATMENT DEVICE SHALL TYPICALLY UTILIZE AN EXTERNAL BYPASS TO DIVERT EXCESSIVE FLOWS. INTERNAL BYPASS SYSTEMS SHALL BE EQUIPPED WITH A FLOATABLES BAFFLE, AND MUST PASS WATER OVER THE CARTRIDGE DECK, AND AVOID PASSAGE THROUGH THE SUMP AND/OR CARTRIDGE FILTRATION ZONE.
- D. THE STORMWATER QUALITY FILTER TREATMENT DEVICE SHALL TREAT 100% OF THE REQUIRED WATER QUALITY TREATMENT FLOW BASED ON A MAXIMUM TREATMENT FLUX RATE (SURFACE LOADING RATE) ACROSS THE MEMBRANE FILTER CARTRIDGES NOT TO EXCEED 0.21 GPM/FT2 (0.142 LPS/M2).
- E. AT A MINIMUM, THE STORMWATER QUALITY FILTER DEVICE SHALL HAVE BEEN FIELD TESTED AND VERIFIED WITH A MINIMUM 25 QUALIFYING STORM EVENTS AND FIELD MONITORING CONDUCTED ACCORDING TO THE TARP TIER II OR TAPE FIELD TEST PROTOCOL, AND HAVE RECEIVED NJCAT VERIFICATION.
- F. THE STORMWATER QUALITY FILTER TREATMENT DEVICE SHALL HAVE DEMONSTRATED A MINIMUM MEDIAN TSS REMOVAL EFFICIENCY OF 85% AND A MINIMUM MEDIAN SSC REMOVAL EFFICIENCY OF 95%.
- G. THE STORMWATER QUALITY FILTER TREATMENT DEVICE SHALL HAVE DEMONSTRATED THE ABILITY TO CAPTURE FINE PARTICLES AS INDICATED BY A MINIMUM MEDIAN REMOVAL EFFICIENCY OF 75% FOR THE PARTICLE FRACTION LESS THAN 25 MICRONS, AN EFFLUENT D50 OF 15 MICRONS OR LOWER FOR ALL MONITORED STORM EVENTS, AND AN EFFLUENT TURBIDITY OF 15 NTUS OR LOWER.
- H. THE STORMWATER QUALITY FILTER TREATMENT DEVICE SHALL HAVE DEMONSTRATED A MINIMUM MEDIAN TOTAL PHOSPHORUS REMOVAL OF 55%, AND A MINIMUM MEDIAN TOTAL NITROGEN REMOVAL OF 50%.
- I. THE STORMWATER QUALITY FILTER TREATMENT DEVICE SHALL HAVE DEMONSTRATED A MINIMUM MEDIAN TOTAL ZINC REMOVAL OF 50%, AND A MINIMUM MEDIAN TOTAL COPPER REMOVAL OF 75%.

INSPECTION AND MAINTENANCE

- A. DURABILITY OF MEMBRANES ARE SUBJECT TO GOOD HANDLING PRACTICES DURING INSPECTION AND MAINTENANCE (REMOVAL, RINSING, AND REINSERTION) EVENTS, AND SITE SPECIFIC CONDITIONS THAT MAY HAVE HEAVIER OR LIGHTER LOADING ONTO THE CARTRIDGES, AND POLLUTANT VARIABILITY THAT MAY IMPACT THE MEMBRANE STRUCTURAL INTEGRITY. MEMBRANE MAINTENANCE AND REPLACEMENT SHALL BE IN ACCORDANCE WITH MANUFACTURER'S RECOMMENDATIONS.
- B. INSPECTION WHICH INCLUDES TRASH AND FLOATABLES COLLECTION, SEDIMENT DEPTH DETERMINATION, AND VISIBLE DETERMINATION OF BACKWASH POOL DEPTH SHALL BE EASILY CONDUCTED FROM GRADE (OUTSIDE THE STRUCTURE).
- C. MANUAL RINSING OF THE REUSABLE FILTER CARTRIDGES SHALL PROMOTE RESTORATION OF THE FLOW CAPACITY AND SEDIMENT CAPACITY OF THE FILTER CARTRIDGES, EXTENDING CARTRIDGE SERVICE LIFE.
- D. SEDIMENT REMOVAL FROM THE FILTER TREATMENT DEVICE SHALL BE ABLE TO BE CONDUCTED USING A STANDARD MAINTENANCE TRUCK AND VACUUM APPARATUS, AND A MINIMUM ONE POINT OF ENTRY TO THE SUMP THAT IS UNOBSTRUCTED BY FILTER CARTRIDGES.
- E. MAINTENANCE ACCESS SHALL HAVE A MINIMUM CLEAR HEIGHT OF 60" OVER ALL OF THE FILTER CARTRIDGES, OR BE ACCESSIBLE BY A HATCH OR OTHER MECHANISM THAT PROVIDES MINIMUM 60" VERTICAL CLEAR SPACE OVER ALL OF THE FILTER CARTRIDGES. FILTER CARTRIDGES SHALL BE ABLE TO BE LIFTED STRAIGHT VERTICALLY OUT OF THE RECEPTACLES AND DECK FOR THE ENTIRE LENGTH OF THE CARTRIDGE.
- F. FILTER CARTRIDGES SHALL BE ABLE TO BE MAINTAINED WITHOUT THE USE OF ADDITIONAL LIFTING EQUIPMENT.

EXECUTION

- A. THE INSTALLATION OF A WATERTIGHT PRECAST CONCRETE DEVICE SHOULD CONFORM TO ASTM C 891 AND TO ANY STATE HIGHWAY, MUNICIPAL OR LOCAL SPECIFICATIONS FOR THE CONSTRUCTION OF MANHOLES, WHICHEVER IS MORE STRINGENT. SELECTED SECTIONS OF A GENERAL SPECIFICATION THAT ARE APPLICABLE ARE SUMMARIZED BELOW.
- B. THE WATERTIGHT PRECAST CONCRETE DEVICE IS INSTALLED IN SECTIONS IN THE FOLLOWING SEQUENCE:
 - AGGREGATE BASE
 - BASE SLAB
 - TREATMENT CHAMBER AND CARTRIDGE DECK RISER SECTION(S)
 - BYPASS SECTION
 - CONNECT INLET AND OUTLET PIPES
 - CONCRETE RISER SECTION(S) AND/OR TRANSITION SLAB (IF REQUIRED)
 - MAINTENANCE RISER SECTION(S) (IF REQUIRED)
 - FRAME AND ACCESS COVER
- C. INLET AND OUTLET PIPES SHOULD BE SECURELY SET INTO THE DEVICE USING APPROVED PIPE SEALS (FLEXIBLE BOOT CONNECTIONS, WHERE APPLICABLE) SO THAT THE STRUCTURE IS WATERTIGHT, AND SUCH THAT ANY PIPE INTRUSION INTO THE DEVICE DOES NOT IMPACT THE DEVICE FUNCTIONALITY.
- D. ADJUSTMENT UNITS (E.G. GRADE RINGS) SHOULD BE INSTALLED TO SET THE FRAME AND COVER AT THE REQUIRED ELEVATION. THE ADJUSTMENT UNITS SHOULD BE LAID IN A FULL BED OF MORTAR WITH SUCCESSIVE UNITS BEING JOINED USING SEALANT RECOMMENDED BY THE MANUFACTURER. FRAMES FOR THE COVER SHOULD BE SET IN A FULL BED OF MORTAR AT THE ELEVATION SPECIFIED.
- E. IN SOME INSTANCES THE MAINTENANCE ACCESS WALL, IF PROVIDED, SHALL REQUIRE AN EXTENSION ATTACHMENT AND SEALING TO THE PRECAST WALL AND CARTRIDGE DECK AT THE JOB SITE, RATHER THAN AT THE PRECAST FACILITY. IN THIS INSTANCE, INSTALLATION OF THESE COMPONENTS SHALL BE PERFORMED ACCORDING TO INSTRUCTIONS PROVIDED BY THE MANUFACTURER.
- F. FILTER CARTRIDGES SHALL BE INSTALLED IN THE CARTRIDGE DECK AFTER THE CONSTRUCTION SITE IS FULLY STABILIZED AND IN ACCORDANCE WITH THE MANUFACTURERS GUIDELINES AND RECOMMENDATIONS. CONTRACTOR TO CONTACT THE MANUFACTURER TO SCHEDULE CARTRIDGE DELIVERY AND REVIEW PROCEDURES/REQUIREMENTS TO BE COMPLETED TO THE DEVICE PRIOR TO INSTALLATION OF THE CARTRIDGES AND ACTIVATION OF THE SYSTEM.
- G. MANUFACTURER SHALL COORDINATE DELIVERY OF FILTER CARTRIDGES AND OTHER INTERNAL COMPONENTS WITH CONTRACTOR. FILTER CARTRIDGES SHALL BE DELIVERED AND INSTALLED COMPLETE AFTER SITE IS STABILIZED AND UNIT IS READY TO ACCEPT CARTRIDGES. UNIT IS READY TO ACCEPT CARTRIDGES AFTER IS HAS BEEN CLEANED OUT AND ANY STANDING WATER, DEBRIS, AND OTHER MATERIALS HAVE BEEN REMOVED. CONTRACTOR SHALL TAKE APPROPRIATE ACTION TO PROTECT THE FILTER CARTRIDGE RECEPTACLES AND FILTER CARTRIDGES FROM DAMAGE DURING CONSTRUCTION, AND IN ACCORDANCE WITH THE MANUFACTURER'S RECOMMENDATIONS AND GUIDANCE. FOR SYSTEMS WITH CARTRIDGES INSTALLED PRIOR TO FULL SITE STABILIZATION AND PRIOR TO SYSTEM ACTIVATION, THE CONTRACTOR CAN PLUG INLET AND OUTLET PIPES TO PREVENT STORMWATER AND OTHER INFLUENT FROM ENTERING THE DEVICE. PLUGS MUST BE REMOVED DURING THE ACTIVATION PROCESS.
- H. THE MANUFACTURER SHALL PROVIDE AN OWNER'S MANUAL UPON REQUEST.
- I. AFTER CONSTRUCTION AND INSTALLATION, AND DURING OPERATION, THE DEVICE SHALL BE INSPECTED AND CLEANED AS NECESSARY BASED ON THE MANUFACTURER'S RECOMMENDED INSPECTION AND MAINTENANCE GUIDELINES AND THE LOCAL REGULATORY AGENCY/BODY.
- J. WHEN REPLACEMENT MEMBRANE FILTER ELEMENTS AND/OR OTHER PARTS ARE REQUIRED, ONLY MEMBRANE FILTER ELEMENTS AND PARTS APPROVED BY THE MANUFACTURER FOR USE WITH THE STORMWATER QUALITY FILTER DEVICE SHALL BE INSTALLED.

END OF SECTION

The design and information shown on this drawing is provided as a service to the project owner, engineer and contractor by Imbrium Systems ("Imbrium"). Imbrium Systems is not responsible for the use, reuse, reproduction or modification of any information without the prior written consent of Imbrium. Failure to comply with the terms of this disclaimer may result in Imbrium's inability to ensure any liability or responsibility for such use. If discrepancies between the supplied information upon which the design was based and the actual conditions are encountered as the work progresses, these discrepancies must be reported to Imbrium immediately for re-evaluation of the design. Imbrium accepts no liability for the design of the project, or for the accuracy or completeness of the information supplied by others.

#	#	#	#	#	BSF	BY
#	#	#	#	#	INITIAL RELEASE	REVISION DESCRIPTION
#	#	#	#	#	10/01/2014	DATE
#	#	#	#	#	0	MARK

JELLYFISH FILTER SPECIFICATIONS



JF4 STANDARD
Scale = 1:50

www.imbriumsystems.com
info@imbriumsystems.com



7037 Ridge Road, Suite 350, Harrower, MD 21076
USA 888-279-8826 CA 800-555-4871 INTL +1-415-960-9900
Jellyfish Filter
THIS PRODUCT MAY BE PROTECTED BY ONE OR MORE OF THE FOLLOWING PATENT RIGHTS: U.S. NO. 7,967,796; U.S. NO. 7,967,797; U.S. NO. 7,967,798; U.S. NO. 7,967,799; U.S. NO. 7,967,800; U.S. NO. 7,967,801; U.S. NO. 7,967,802; U.S. NO. 7,967,803; U.S. NO. 7,967,804; U.S. NO. 7,967,805; U.S. NO. 7,967,806; U.S. NO. 7,967,807; U.S. NO. 7,967,808; U.S. NO. 7,967,809; U.S. NO. 7,967,810; U.S. NO. 7,967,811; U.S. NO. 7,967,812; U.S. NO. 7,967,813; U.S. NO. 7,967,814; U.S. NO. 7,967,815; U.S. NO. 7,967,816; U.S. NO. 7,967,817; U.S. NO. 7,967,818; U.S. NO. 7,967,819; U.S. NO. 7,967,820; U.S. NO. 7,967,821; U.S. NO. 7,967,822; U.S. NO. 7,967,823; U.S. NO. 7,967,824; U.S. NO. 7,967,825; U.S. NO. 7,967,826; U.S. NO. 7,967,827; U.S. NO. 7,967,828; U.S. NO. 7,967,829; U.S. NO. 7,967,830; U.S. NO. 7,967,831; U.S. NO. 7,967,832; U.S. NO. 7,967,833; U.S. NO. 7,967,834; U.S. NO. 7,967,835; U.S. NO. 7,967,836; U.S. NO. 7,967,837; U.S. NO. 7,967,838; U.S. NO. 7,967,839; U.S. NO. 7,967,840; U.S. NO. 7,967,841; U.S. NO. 7,967,842; U.S. NO. 7,967,843; U.S. NO. 7,967,844; U.S. NO. 7,967,845; U.S. NO. 7,967,846; U.S. NO. 7,967,847; U.S. NO. 7,967,848; U.S. NO. 7,967,849; U.S. NO. 7,967,850; U.S. NO. 7,967,851; U.S. NO. 7,967,852; U.S. NO. 7,967,853; U.S. NO. 7,967,854; U.S. NO. 7,967,855; U.S. NO. 7,967,856; U.S. NO. 7,967,857; U.S. NO. 7,967,858; U.S. NO. 7,967,859; U.S. NO. 7,967,860; U.S. NO. 7,967,861; U.S. NO. 7,967,862; U.S. NO. 7,967,863; U.S. NO. 7,967,864; U.S. NO. 7,967,865; U.S. NO. 7,967,866; U.S. NO. 7,967,867; U.S. NO. 7,967,868; U.S. NO. 7,967,869; U.S. NO. 7,967,870; U.S. NO. 7,967,871; U.S. NO. 7,967,872; U.S. NO. 7,967,873; U.S. NO. 7,967,874; U.S. NO. 7,967,875; U.S. NO. 7,967,876; U.S. NO. 7,967,877; U.S. NO. 7,967,878; U.S. NO. 7,967,879; U.S. NO. 7,967,880; U.S. NO. 7,967,881; U.S. NO. 7,967,882; U.S. NO. 7,967,883; U.S. NO. 7,967,884; U.S. NO. 7,967,885; U.S. NO. 7,967,886; U.S. NO. 7,967,887; U.S. NO. 7,967,888; U.S. NO. 7,967,889; U.S. NO. 7,967,890; U.S. NO. 7,967,891; U.S. NO. 7,967,892; U.S. NO. 7,967,893; U.S. NO. 7,967,894; U.S. NO. 7,967,895; U.S. NO. 7,967,896; U.S. NO. 7,967,897; U.S. NO. 7,967,898; U.S. NO. 7,967,899; U.S. NO. 7,967,900; U.S. NO. 7,967,901; U.S. NO. 7,967,902; U.S. NO. 7,967,903; U.S. NO. 7,967,904; U.S. NO. 7,967,905; U.S. NO. 7,967,906; U.S. NO. 7,967,907; U.S. NO. 7,967,908; U.S. NO. 7,967,909; U.S. NO. 7,967,910; U.S. NO. 7,967,911; U.S. NO. 7,967,912; U.S. NO. 7,967,913; U.S. NO. 7,967,914; U.S. NO. 7,967,915; U.S. NO. 7,967,916; U.S. NO. 7,967,917; U.S. NO. 7,967,918; U.S. NO. 7,967,919; U.S. NO. 7,967,920; U.S. NO. 7,967,921; U.S. NO. 7,967,922; U.S. NO. 7,967,923; U.S. NO. 7,967,924; U.S. NO. 7,967,925; U.S. NO. 7,967,926; U.S. NO. 7,967,927; U.S. NO. 7,967,928; U.S. NO. 7,967,929; U.S. NO. 7,967,930; U.S. NO. 7,967,931; U.S. NO. 7,967,932; U.S. NO. 7,967,933; U.S. NO. 7,967,934; U.S. NO. 7,967,935; U.S. NO. 7,967,936; U.S. NO. 7,967,937; U.S. NO. 7,967,938; U.S. NO. 7,967,939; U.S. NO. 7,967,940; U.S. NO. 7,967,941; U.S. NO. 7,967,942; U.S. NO. 7,967,943; U.S. NO. 7,967,944; U.S. NO. 7,967,945; U.S. NO. 7,967,946; U.S. NO. 7,967,947; U.S. NO. 7,967,948; U.S. NO. 7,967,949; U.S. NO. 7,967,950; U.S. NO. 7,967,951; U.S. NO. 7,967,952; U.S. NO. 7,967,953; U.S. NO. 7,967,954; U.S. NO. 7,967,955; U.S. NO. 7,967,956; U.S. NO. 7,967,957; U.S. NO. 7,967,958; U.S. NO. 7,967,959; U.S. NO. 7,967,960; U.S. NO. 7,967,961; U.S. NO. 7,967,962; U.S. NO. 7,967,963; U.S. NO. 7,967,964; U.S. NO. 7,967,965; U.S. NO. 7,967,966; U.S. NO. 7,967,967; U.S. NO. 7,967,968; U.S. NO. 7,967,969; U.S. NO. 7,967,970; U.S. NO. 7,967,971; U.S. NO. 7,967,972; U.S. NO. 7,967,973; U.S. NO. 7,967,974; U.S. NO. 7,967,975; U.S. NO. 7,967,976; U.S. NO. 7,967,977; U.S. NO. 7,967,978; U.S. NO. 7,967,979; U.S. NO. 7,967,980; U.S. NO. 7,967,981; U.S. NO. 7,967,982; U.S. NO. 7,967,983; U.S. NO. 7,967,984; U.S. NO. 7,967,985; U.S. NO. 7,967,986; U.S. NO. 7,967,987; U.S. NO. 7,967,988; U.S. NO. 7,967,989; U.S. NO. 7,967,990; U.S. NO. 7,967,991; U.S. NO. 7,967,992; U.S. NO. 7,967,993; U.S. NO. 7,967,994; U.S. NO. 7,967,995; U.S. NO. 7,967,996; U.S. NO. 7,967,997; U.S. NO. 7,967,998; U.S. NO. 7,967,999; U.S. NO. 8,000,000.

DATE: #####

DESIGNED: _____ DRAWN: _____

CHECKED: BSF APPROVED: SP

PROJECT #: ##### PROJECT NAME: #####

SHEET: 2 OF 2

STANDARD PERFORMANCE SPECIFICATION STORMWATER QUALITY – MEMBRANE FILTRATION TREATMENT DEVICE

PART 1 – GENERAL

1.1 WORK INCLUDED

This section specifies requirements for selecting, sizing, and designing an underground stormwater quality membrane filtration treatment device that removes pollutants from stormwater runoff through the unit operations of sedimentation, floatation, and membrane filtration.

1.2 REFERENCE STANDARDS & PROCEDURES

ISO 14034:2016 Environmental Management – Environmental Technology Verification (ETV)

1.3 SUBMITTALS

- 1.3.1 All submittals, including sizing reports & shop drawings, shall be submitted upon request with each order to the contractor then forwarded to the Engineer of Record for review and acceptance. Shop drawings shall detail all OGS components, elevations, and sequence of construction.
- 1.3.2 Alternative devices shall have features identical to or greater than the specified device, including: filtration surface area, treatment chamber diameter, treatment chamber wet volume, sediment storage volume, and oil storage volume.
- 1.3.3 Unless directed otherwise by the Engineer of Record, filtration treatment device product substitutions or alternatives submitted within ten days prior to project bid shall not be accepted. All alternatives or substitutions submitted shall be signed and sealed by a local registered Professional Engineer, based on the exact same criteria detailed in Section 3, in entirety, subject to review and approval by the Engineer of Record.

PART 2 – PRODUCTS

2.1 GENERAL

- 2.1.1 Maintenance Access to Captured Pollutants The filter device shall contain an opening(s) that provides maintenance access for removal of accumulated floatable pollutants and sediment, removal of and replacement of filter cartridges, cleaning of the sump, and rinsing of the internal components. Access shall have a minimum clear vertical clear space over all of the filter cartridges. Filter cartridges shall be able to be lifted straight vertically out of their installed placement for the entire length of the cartridge.
- 2.1.2 Pollutant Storage: The Filter device shall include a sump for sediment storage, and a protected volume for the capture and storage of petroleum hydrocarbons and buoyant gross pollutants.

PART 3 – PERFORMANCE

3.1 GENERAL

- 3.1.1 Verification – The stormwater quality filter treatment device shall have been field tested in accordance with either TARP Tier II Protocol (TARP, 2003) and New Jersey Tier II Stormwater Test Requirements – Amendments to TARP Tier II Protocol (NJDEP, 2009) or Washington State Technology Assessment Protocol – Ecology (TAPE), 2011 or later version. The field test shall have been verified in accordance with ISO 14034:2016 Environmental Management – Environmental Technology Verification (ETV). See Section 3.2 of this specification for field test performance requirements.

3.2 FIELD TEST PERFORMANCE

The field test (as specified in section 3.1.1) shall have monitored a minimum of twenty (20) TARP or TAPE qualifying storm events, and report at **minimum** the following results:

- 3.2.1 Suspended Solids Removal - The stormwater quality filter treatment device shall have ISO 14034 ETV verified load based median TSS removal efficiency of at least 85% and load based median SSC removal efficiency of at least 98%.
- 3.2.2 Runoff Volume – The stormwater quality filter treatment device shall be engineered, designed, and sized to treat a minimum of 90 percent of the annual runoff volume determined from use of a minimum 15-year rainfall data set.
- 3.2.3 Fine Particle Removal - The stormwater quality filter treatment device shall have demonstrated the ability to capture fine particles as indicated by a minimum median removal efficiency of 75% for the particle fraction less than 25 microns, and an effluent d_{50} of 15 microns or lower for all monitored storm events.
- 3.2.4 Turbidity Reduction - The stormwater quality filter treatment device shall have demonstrated the ability to reduce turbidity such that effluent turbidity is 15 NTU or lower.
- 3.2.5 Nutrients & Metals – The stormwater quality filter treatment device shall have ISO 14034 ETV Verified minimum load based removal efficiencies for the following:
- 3.2.5.1 Total Phosphorus (TP) Removal - Median TP removal efficiency of at least 49%.
- 3.2.5.2 Total Nitrogen (TN) Removal - Median TN removal efficiency of at least 39%.
- 3.2.5.3 Total Zinc (Zn) Removal - Median Zn removal efficiency of at least 69%.
- 3.2.5.4 Total Copper (Cu) Removal - Median Cu removal efficiency of at least 91%.

END OF SECTION

CSO/STORMWATER MANAGEMENT



HYDROVEX[®] VHV / SVHV
Vertical Vortex Flow Regulator

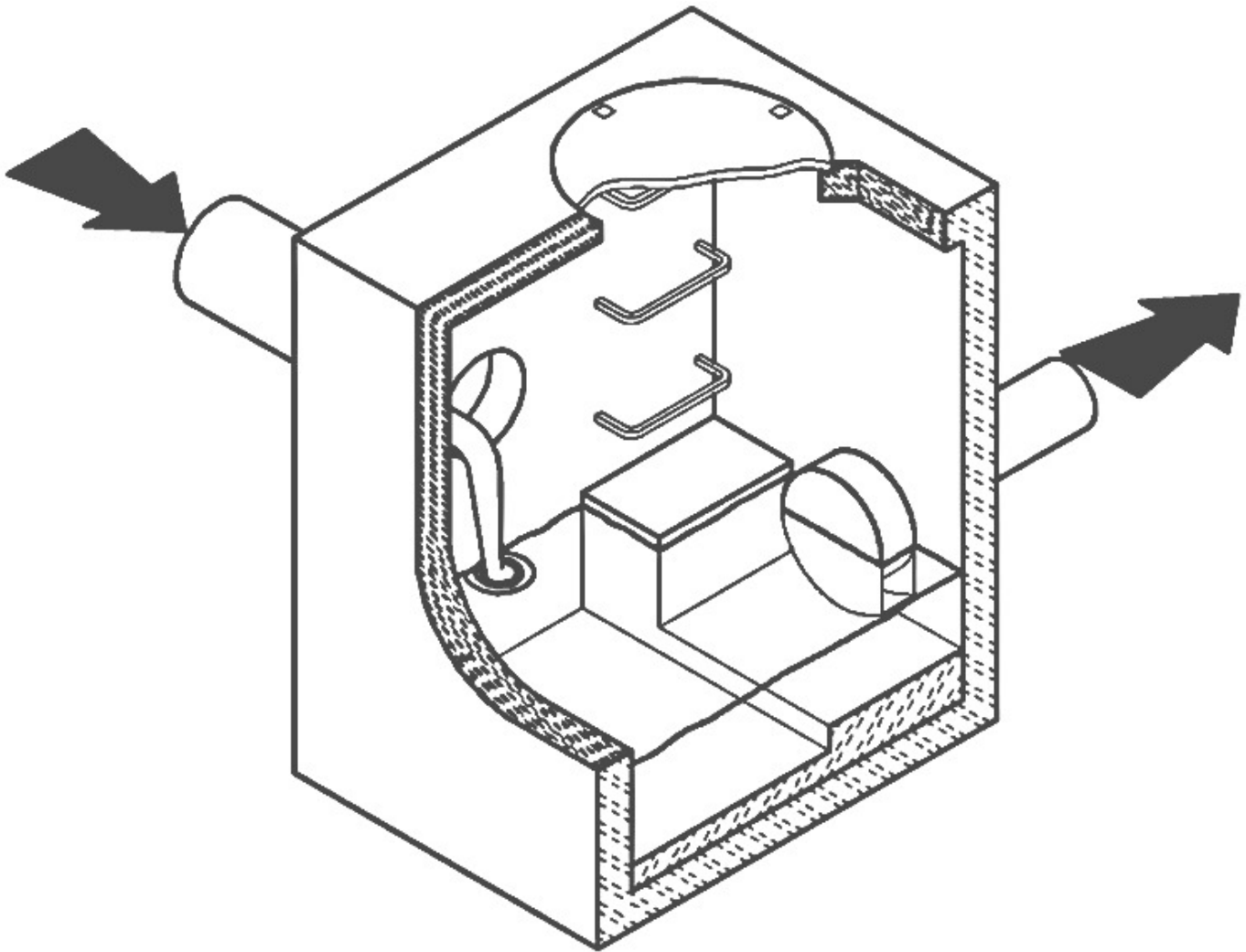

JOHN MEUNIER

HYDROVEX® VHV / SVHV VERTICAL VORTEX FLOW REGULATOR

APPLICATIONS

One of the major problems of urban wet weather flow management is the runoff generated after a heavy rainfall. During a storm, uncontrolled flows may overload the drainage system and cause flooding. Due to increased velocities, sewer pipe wear is increased dramatically and results in network deterioration. In a combined sewer system, the wastewater treatment plant may also experience significant increases in flows during storms, thereby losing its treatment efficiency.

A simple means of controlling excessive water runoff is by controlling excessive flows at their origin (manholes). **John Meunier Inc.** manufactures the **HYDROVEX® VHV / SVHV** line of vortex flow regulators to control stormwater flows in sewer networks, as well as manholes.

The vortex flow regulator design is based on the fluid mechanics principle of the forced vortex. This grants flow regulation without any moving parts, thus reducing maintenance. The operation of the regulator, depending on the upstream head and discharge, switches between orifice flow (gravity flow) and vortex flow. Although the concept is quite simple, over 12 years of research have been carried out in order to get a high performance.

The **HYDROVEX® VHV / SVHV** Vertical Vortex Flow Regulators (refer to **Figure 1**) are manufactured entirely of stainless steel, and consist of a hollow body (1) (in which flow control takes place) and an outlet orifice (7). Two rubber "O" rings (3) seal and retain the unit inside the outlet pipe. Two stainless steel retaining rings (4) are welded on the outlet sleeve to ensure that there is no shifting of the "O" rings during installation and use.

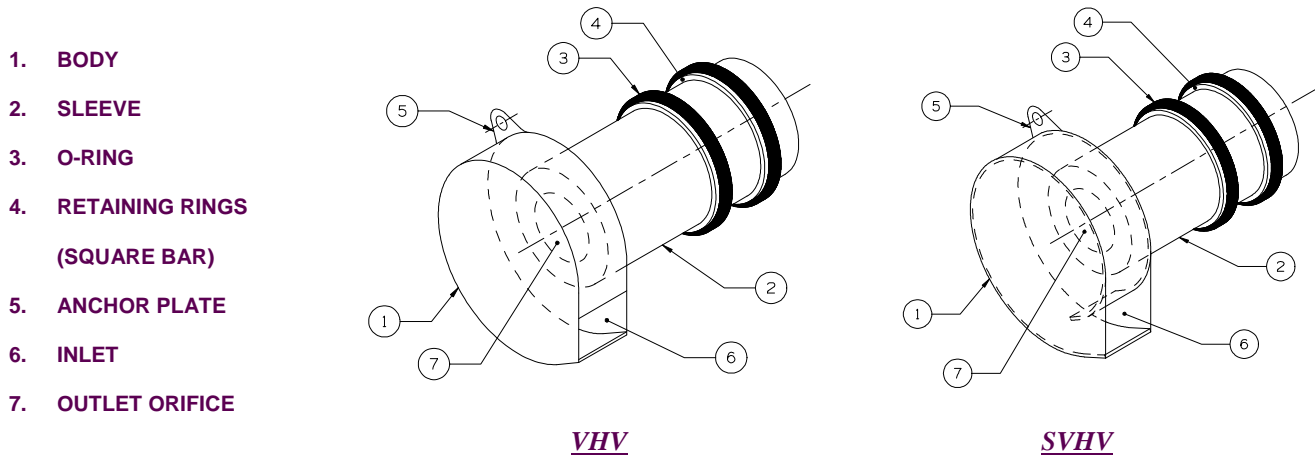

FIGURE 1: HYDROVEX® VHV-SVHV VERTICAL VORTEX FLOW REGULATORS

ADVANTAGES

- The **HYDROVEX® VHV / SVHV** line of flow regulators are manufactured entirely of stainless steel, making them durable and corrosion resistant.
- Having no moving parts, they require minimal maintenance.
- The geometry of the **HYDROVEX® VHV / SVHV** flow regulators allows a control equal to an orifice plate, having a cross section area 4 to 6 times smaller. This decreases the chance of blockage of the regulator, due to sediments and debris found in stormwater flows. **Figure 2** illustrates the comparison between a regulator model 100 SVHV-2 and an equivalent orifice plate. One can see that for the same height of water, the regulator controls a flow approximately four times smaller than an equivalent orifice plate.
- Installation of the **HYDROVEX® VHV / SVHV** flow regulators is quick and straightforward and is performed after all civil works are completed.
- Installation requires no special tools or equipment and may be carried out by any contractor.
- Installation may be carried out in existing structures.

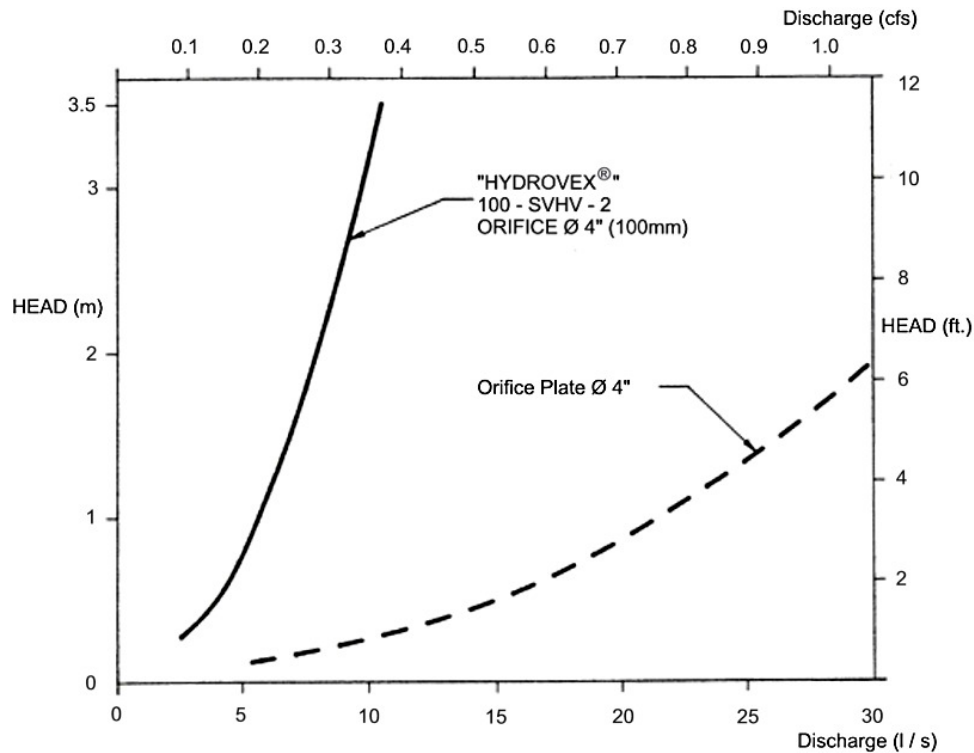

FIGURE 2: DISCHARGE CURVE SHOWING A HYDROVEX® FLOW REGULATOR VS AN ORIFICE PLATE

SELECTION

Selection of a **VHV** or **SVHV** regulator can be easily made using the selection charts found at the back of this brochure (see **Figure 3**). These charts are a graphical representation of the maximum upstream water pressure (head) and the maximum discharge at the manhole outlet. The maximum design head is the difference between the maximum upstream water level and the invert of the outlet pipe. All selections should be verified by John Meunier Inc. personnel prior to fabrication.

Example:

- ✓ Maximum design head 2m (6.56 ft.)
- ✓ Maximum discharge 6 L/s (0.2 cfs)
- ✓ Using **Figure 3** - VHV model required is a **75 VHV-1**

INSTALLATION REQUIREMENTS

All **HYDROVEX®** **VHV** / **SVHV** flow regulators can be installed in circular or square manholes. **Figure 4** gives the various minimum dimensions required for a given regulator. *It is imperative to respect the minimum clearances shown to ensure easy installation and proper functioning of the regulator.*

SPECIFICATIONS

In order to specify a **HYDROVEX**[®] regulator, the following parameters must be defined:

- The model number (ex: 75-VHV-1)
- The diameter and type of outlet pipe (ex: 6" diam. SDR 35)
- The desired discharge (ex: 6 l/s or 0.21 CFS)
- The upstream head (ex: 2 m or 6.56 ft.) *
- The manhole diameter (ex: 36" diam.)
- The minimum clearance "H" (ex: 10 inches)
- The material type (ex: 304 s/s, 11 Ga. standard)

* *Upstream head is defined as the difference in elevation between the maximum upstream water level and the invert of the outlet pipe where the **HYDROVEX**[®] flow regulator is to be installed.*

PLEASE NOTE THAT WHEN REQUESTING A PROPOSAL, WE SIMPLY REQUIRE THAT YOU PROVIDE US WITH THE FOLLOWING:

- *project design flow rate*
- *pressure head*
- *chamber's outlet pipe diameter and type*



Typical VHV model in factory

OPTIONS



FV – SVHV (mounted on sliding plate)



VHV-1-O (standard model with odour control inlet)



FV – VHV-O (mounted on sliding plate with odour control inlet)



VHV with Gooseneck assembly in existing chamber without minimum release at the bottom



VHV with air vent for minimal slopes



VHV Vertical Vortex Flow Regulator

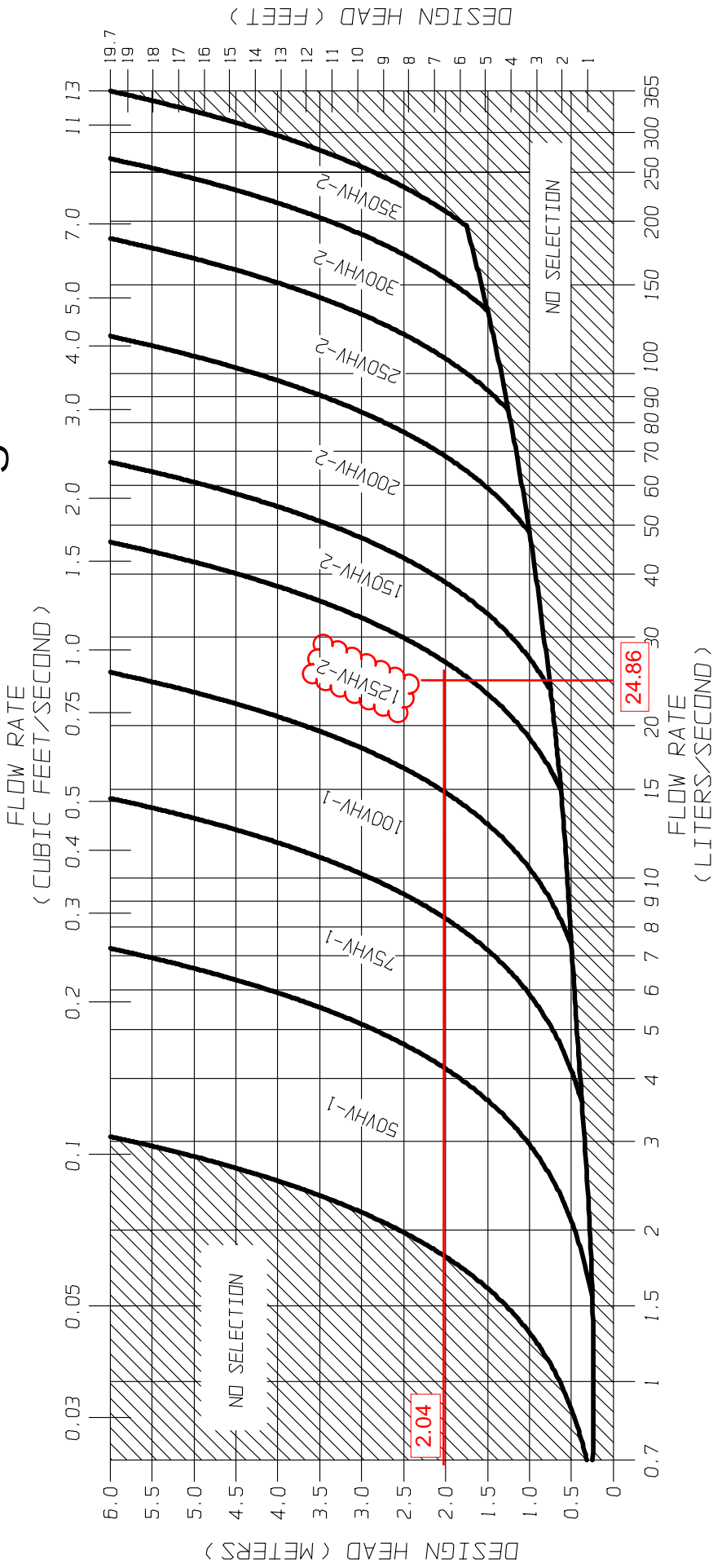
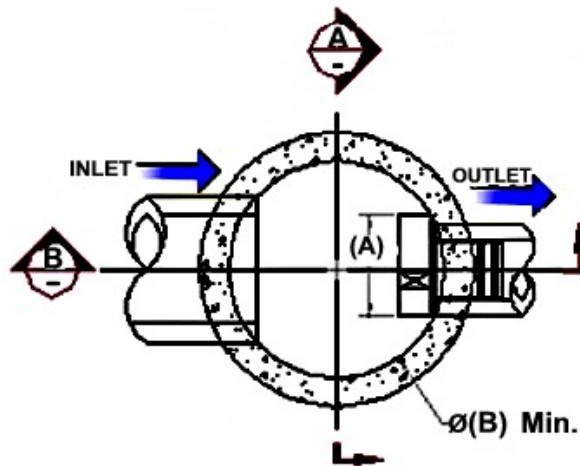

FIGURE 3 - VHV

JOHN MEUNIER

**FLOW REGULATOR TYPICAL INSTALLATION IN CIRCULAR MANHOLE
FIGURE 4 (MODEL VHV)**

Model Number	Regulator Diameter		Minimum Manhole Diameter		Minimum Outlet Pipe Diameter		Minimum Clearance	
	A (mm)	A (in.)	B (mm)	B (in.)	C (mm)	C (in.)	H (mm)	H (in.)
50VHV-1	150	6	600	24	150	6	150	6
75VHV-1	250	10	600	24	150	6	150	6
100VHV-1	325	13	900	36	150	6	200	8
125VHV-2	275	11	900	36	150	6	200	8
150VHV-2	350	14	900	36	150	6	225	9
200VHV-2	450	18	1200	48	200	8	300	12
250VHV-2	575	23	1200	48	250	10	350	14
300VHV-2	675	27	1600	64	250	10	400	16
350VHV-2	800	32	1800	72	300	12	500	20



CIRCULAR WELL

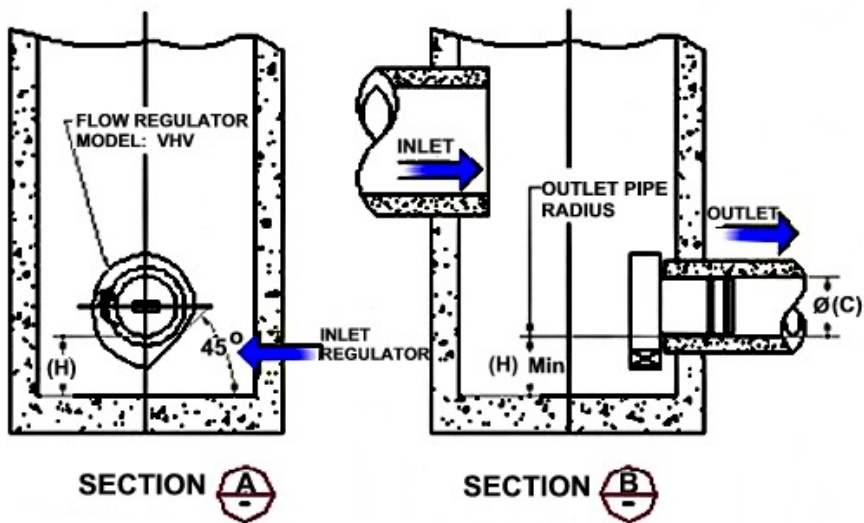

SECTION **A**

SECTION **B**

INSTALLATION

The installation of a **HYDROVEX**[®] regulator may be undertaken once the manhole and piping is in place. Installation consists of simply fitting the regulator into the outlet pipe of the manhole. **John Meunier Inc.** recommends the use of a lubricant on the outlet pipe, in order to facilitate the insertion and orientation of the flow controller.

MAINTENANCE

HYDROVEX[®] regulators are manufactured in such a way as to be maintenance free; however, a periodic inspection (every 3-6 months) is suggested in order to ensure that neither the inlet nor the outlet has become blocked with debris. The manhole should undergo periodically, particularly after major storms, inspection and cleaning as established by the municipality

GUARANTY

The **HYDROVEX**[®] line of **VHV / SVHV** regulators are guaranteed against both design and manufacturing defects for a period of 5 years. Should a unit be defective, **John Meunier Inc.** is solely responsible for either modification or replacement of the unit.

John Meunier Inc.

ISO 9001 : 2008

Head Office

4105 Sartelon

Saint-Laurent (Quebec) Canada H4S 2B3

Tel.: 514-334-7230 www.johnmeunier.com

Fax: 514-334-5070 cs@johnmeunier.com

Ontario Office

2000 Argentia Road, Plaza 4, Unit 430

Mississauga (Ontario) Canada L5N 1W1

Tel.: 905-286-4846 www.johnmeunier.com

Fax: 905-286-0488 ontario@johnmeunier.com

USA Office

2209 Menlo Avenue

Glenside, PA USA 19038

Tel.: 412-417-6614 www.johnmeunier.com

Fax: 215-885-4741 astele@johnmeunier.com

APPENDIX E
Civil Engineering Drawings

APPENDIX F
Survey, As-Builts

TOPOGRAPHICAL PLAN OF SURVEY OF
PART OF LOT 11
CONCESSION 3 (RIDEAU FRONT)
Geographic Township of Nepean
CITY OF OTTAWA
 Surveyed by Annis, O'Sullivan, Vollebek Ltd.

Scale 1 : 400

Metric
 DISTANCES SHOWN ON THIS PLAN ARE IN METRES AND
 CAN BE CONVERTED TO FEET BY DIVIDING BY 0.3048

Surveyor's Certificate

I CERTIFY THAT:
 1. This survey and plan are correct and in accordance with the Surveys Act and the Surveyors Act and the regulations made under them.
 2. The survey was completed on the 19th day of January, 2022.

Date: Jan 21/22

 T. Hartwick
 Ontario Land Surveyor

Notes & Legend

Symbol	Denotes
□	Survey Monument Planted
■	Survey Monument Found
SIB	Standard Iron Bar
SSIB	Short Standard Iron Bar
IB	Iron Bar
CC	Cut Cross
(WIT)	Witness
Meas.	Measured
(AOG)	Annis, O'Sullivan, Vollebek Ltd.
(PI)	Plan 4R-33597
(P2)	(AOG) Plan dated October 29, 2021.
— OHW —	Overhead Wires
CSP	Corrugated Steel Pipe
CPP	Corrugated Plastic Pipe
CCP	Concrete Pipe
CLF	Chain Link Fence
PWF	Post and Wire Fence
BOS	Bottom of Slope
TOS	Top of Slope
DC	Ditch Centerline
Inv.	Invert
RWT	Timber Retaining Wall
o WP	Wood Pole
o UP	Utility Pole
o AN	Anchor
o	Diameter
+ 65.00	Location of Elevations
+ 65.00*	Top of Retaining Wall Elevation

Distances shown on this plan are ground distances and can be converted to grid distances by multiplying by the combined scale factor of 0.999933.

Bearings are grid, derived from Can-Net 2016 Real Time Network GPS observations referenced to Specified Control Points 01919791338 and 01919871649, MTM Zone 9 (76°30' West Longitude) NAD-83 (original).

ASSOCIATION OF ONTARIO
 LAND SURVEYORS
 PLAN SUBMISSION FORM

V-22497



THIS PLAN IS NOT VALID UNLESS
 IT IS AN EMBOSSED ORIGINAL
 COPY ISSUED BY THE SURVEYOR
 In accordance with
 Regulation 1026, Section 29 (3).

© Annis, O'Sullivan, Vollebek Ltd. 2022. THIS PLAN IS PROTECTED BY COPYRIGHT.
ANNIS, O'SULLIVAN, VOLLEBEK LTD.
 14 Concourse Gate, Suite 500
 Nepean, Ont. K2E 7S6
 Phone: (613) 727-0850 / Fax: (613) 727-1079
 Email: Nepean@aosvltd.com
 Job No. 22410-21 Borrisokane January 21, 2022(2)

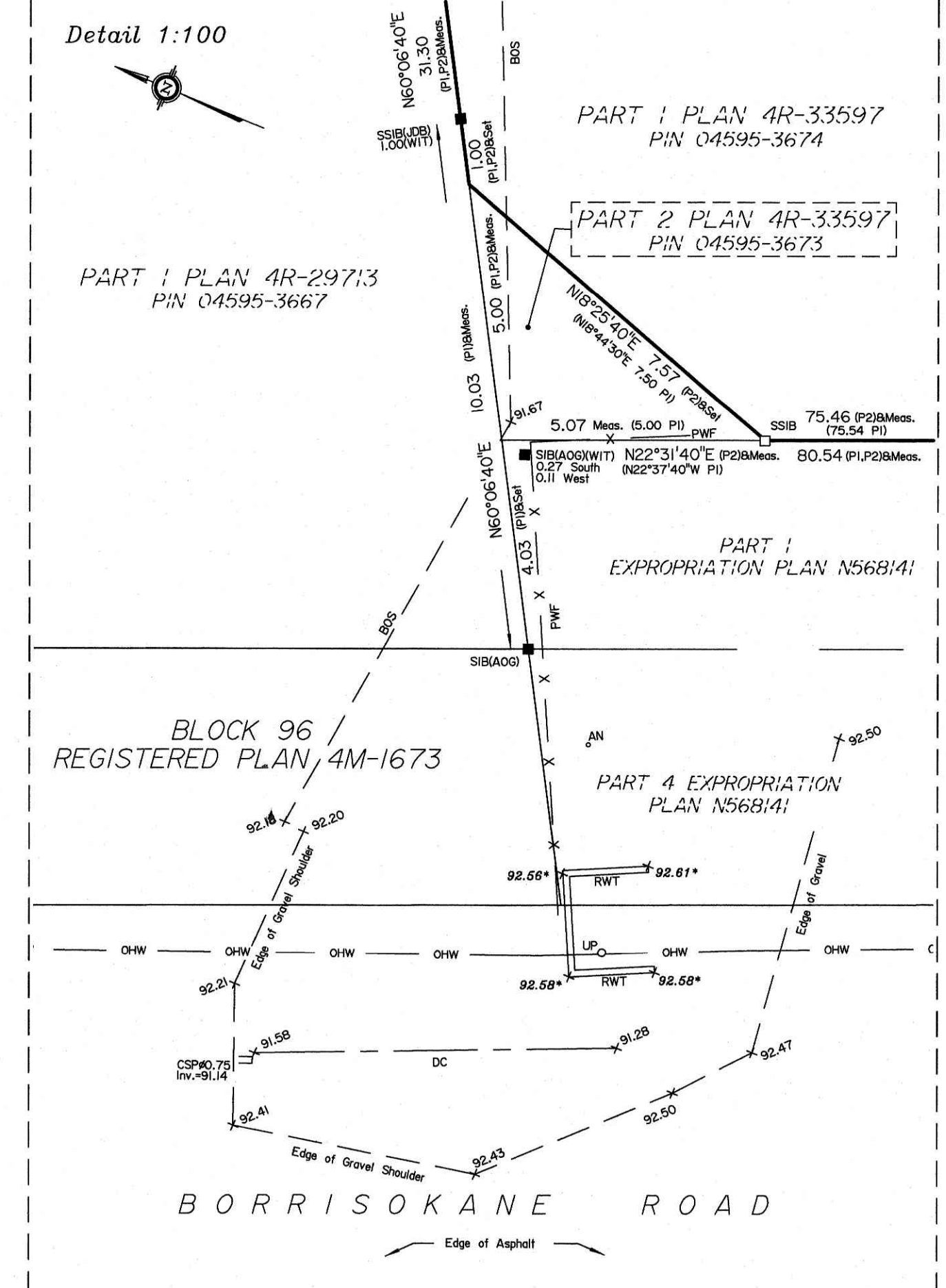
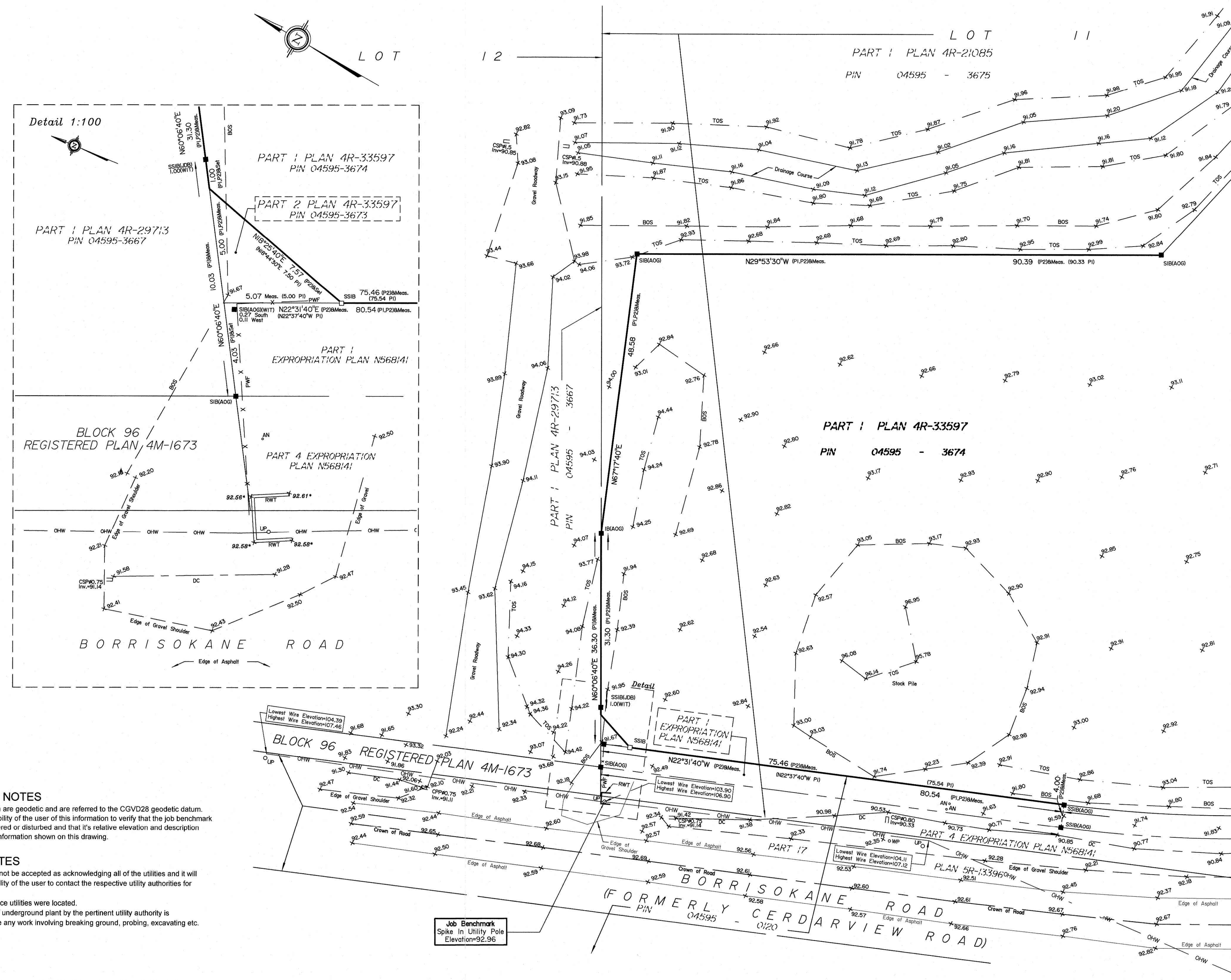

ELEVATION NOTES
 1. Elevations shown are geodetic and are referred to the CGVD28 geodetic datum.
 2. It is the responsibility of the user of this information to verify that the job benchmark has not been altered or disturbed and that its relative elevation and description agrees with the information shown on this drawing.

UTILITY NOTES
 1. This drawing cannot be accepted as acknowledging all of the utilities and it will be the responsibility of the user to contact the respective utility authorities for confirmation.
 2. Only visible surface utilities were located.
 3. A field location of underground plant by the pertinent utility authority is mandatory before any work involving breaking ground, probing, excavating etc.