



# STORMWATER MANAGEMENT AND SERVICEABILITY REPORT

REVISION 9 – LIB KANATA  
KANATA AVENUE AND MARITIME WAY

CITY OF OTTAWA, ONTARIO



2023-03-17

ÉQUIPE LAURENCE INC.

File: 60.04.01

Mars 2023

135, boul. de Sainte-Adèle,  
Sainte-Adèle (Qc)  
J8B 0J4

531, boul. Manseau  
Joliette (Qc)  
J6E 3E3

495, rue Frontenac  
Mont-Laurier (Qc)  
J9L 2L3

T 450 227-1857  
info@equipelaurence.ca  
equipelaurence.ca

[Sainte-Adèle](#)  
[Boisbriand](#)  
[Joliette](#)  
[Mont-Laurier](#)  
[Gatineau](#)  
[Sorel-Tracy](#)

**PROJECT:** REVISION 9 – LIB KANATA  
Stormwater Management and Serviceability Report

**FILE:** 60.04.01

**PREPARED BY:**



---

Benoit Bray, P.Eng.  
*Équipe Laurence inc.*

**PRESENTED TO:** Groupe EMD – Bâtimo Inc.  
6485, rue Doris-Lussier, suite 400  
Boisbriand, QC  
J7H 0E8 Canada

---

**ISSUE:** Mars 16<sup>th</sup>, 2023

## TABLE OF CONTENTS

<b>1.0</b>	<b>INTRODUCTION.....</b>	<b>1</b>
<b>2.0</b>	<b>STORMWATER MANAGEMENT .....</b>	<b>1</b>
2.1	CALCULATION OF PRE-DEVELOPMENT FLOWS.....	2
2.2	DESIGN CRITERIA FOR POST-DEVELOPMENT FLOWS.....	2
2.3	CATCH BASIN SUB-AREAS.....	3
2.4	POST-DEVELOPMENT: UNCONTROLLED FLOWS .....	4
2.5	POST-DEVELOPMENT: CONTROLLED FLOWS AND STORAGE REQUIREMENTS.....	4
2.6	STORMWATER QUALITY .....	6
2.7	EROSION AND SEDIMENT CONTROL .....	7
2.8	INFILTRATION .....	8
<b>3.0</b>	<b>SANITARY SEWER DESIGN FLOWS .....</b>	<b>9</b>
3.1	POPULATION DENSITY.....	9
3.2	AVERAGE WASTEWATER FLOWS AND PEAKING FACTORS.....	10
3.3	EXTRANEOUS FLOWS.....	11
3.4	TOTAL SANITARY SEWER DESIGN FLOW .....	11
<b>4.0</b>	<b>DOMESTIC WATER DEMAND.....</b>	<b>11</b>
4.1	BOUNDARY CONDITIONS .....	12
<b>5.0</b>	<b>REQUIRED FIRE DEMAND .....</b>	<b>14</b>

## APPENDICES

APPENDIX A: CIVIL ENGINEERING DRAWINGS

APPENDIX B: BACKGROUND DOCUMENTS

APPENDIX C: STORMWATER FLOWS AND STORAGE REQUIREMENTS – DETAILED CALCULATIONS

APPENDIX D: SANITARY SEWER DESIGN FLOWS – DETAILED CALCULATIONS

APPENDIX E: DOMESTIC WATER DEMAND – DETAILED CALCULATIONS

APPENDIX F: REQUIRED FIRE DEMAND – DETAILED CALCULATIONS

APPENDIX G: TECHNICAL DRAWINGS

## 1.0 INTRODUCTION

This project consists of the residential development of Parcels 2, 3 and 5 located at the intersection of Kanata Avenue and Maritime Way, in the suburb of Kanata. Équipe Laurence Inc. was mandated to carry out the design of the drinking water, storm and sanitary sewer systems that serve the proposed building as well as the stormwater management report. The civil engineering plans depicting the general features of the site, such as the parking areas, sewer structures and landscaping is attached to this report in Appendix A.

In this report, the design and calculations of the sanitary sewer, domestic water and stormwater management systems will be discussed. The design was completed in accordance with the following design guidelines and regulations:

- Ottawa Sewer Design Guidelines (October 2012)
- *Technical memo* written by Justin Armstrong, Project Manager from the Planning, Infrastructure and Economic Development Department. File No. PC2021-0079
- *Stormwater Management Report Kanata Town Centre*, Volumes 1 & 2, prepared by J.L. Richards, (January 1999)
- Ottawa Design Guidelines – Water Distribution (July 2010)
- Ottawa Technical Bulletin ISTB-2018-02 (March 2018)
- Water Supply for Public Fire Protection, *Fire Underwriters Survey* (2020)

## 2.0 STORMWATER MANAGEMENT

As part of the stormwater management system, the flow of water will be controlled on-site and discharged through two connections. The first phase will drain toward the stormwater sewer below the shared road access between our project and the one at 180 Kanata Avenue through a 375 mm diameter pipe. The water from the second phase will drain through a 300 mm diameter service connection. This pipe will be connected to the existing 1625 mm diameter storm sewer under Maritime way as shown on the attached plans.

According to a complementary land survey completed by *Annis, O'Sullivan, Vollebakk Ltd.* on April 13, 2021, attached in Appendix B, the subject site is primarily occupied by forested areas. In

addition, the elevation difference measured between the back of the lot and the property line along the road right-of-way varies between approximately 2 and 5 m.

For the design of the stormwater management system, the calculations were done to ensure that the post-development flows are equivalent to or lesser than the pre-development overland flow. Hence, the stormwater flows for the developed site as well as the storage requirements will be explored in the following sections.

## 2.1 Calculation of Pre-development Flows

The pre-development overland flow was determined using the criteria outlined in the *Ottawa Sewer Design Guidelines (2012)* as well as the following site information:

- The proposed site area of 1.490 hectares.
- The Rational Method for the calculation of flow as indicated in Section 5.4.4.1 of the design guideline.
- The IDF curves and equations as indicated in Section 5.4.2 of the design guideline.
- The runoff coefficients as shown in Table 5.7 of the design guideline.

The time of concentration for the pre-developed site is of 20 minutes and the runoff coefficient used is 0.57 for both the 5-yr and 100-yr predevelopment storm events as described in the *Stormwater Management Report Kanata Town Centre*.

Using these values, the pre-development overland flow is 165.8 L/s for the 5-yr storm events. The detailed calculations are attached in Appendix C.

## 2.2 Design Criteria for Post-Development Flows

According to the *Technical Memo*, the allowable release rate to the minor system for the proposed site will be equivalent to the pre-development flow for the 5-year storm event. As mentioned in the previous section, the predevelopment flow for the 5-year storm is 165.8 L/s. Moreover, it is mentioned that flows in excess of the 5-yr storm allowable release rate, up to and including the 100-yr storm event, must be retained on site. Hence, these storm events must be considered for the post-development flow calculations.

In addition, to account for the effects of climate change, a 20% increase will be added to the rainfall intensities of the 100-yr storm event, as per the *Ottawa Sewer Design Guideline*.

## 2.3 Catch Basin Sub-Areas

The catch basins sub-areas are used to collect the stormwater from its associated area. The areas of impervious and pervious surfaces are determined for each catch basin. The catch basin sub-areas are depicted in Appendix C.

The runoff coefficients used for the post-development flow calculations for the 5-year storm event are shown in the table below. The 100-year runoff coefficients are determined by increasing the following coefficients by 25%, as per the *Ottawa Sewer Design Guideline*.

Table 1: Runoff Coefficients for Various Land Uses

Land Use	5-year Runoff Coefficient	100-year Runoff Coefficient
Forest area	0.20	0.25
Grass area	0.25	0.3125
Paved and roof areas	0.90	1.00

Using this information, the average runoff coefficients corresponding to both storm events are calculated. The results are shown in Table 2 and the detailed calculations are presented in Appendix C.

Table 2: Average Runoff Coefficients for the Various Catch Basin Sub-Areas

Drainage area	Total area (m <sup>2</sup> )	5-year runoff coefficient	100-year runoff coefficient
CB-01	555	0.900	1.000
CB-02	592	0.900	1.000
CB-03	565	0.900	1.000
Building Phase 2	1583	0.900	1.000
CB-04	734	0.799	0.893
CB-05	567	0.900	1.000
CB-06	635	0.900	1.000
CB-07	430	0.900	1.000
CB-08	533	0.900	1.000
CB-09	674	0.827	0.922
CB-10	462	0.823	0.918
Building Phase 1	3731	0.900	1.000
UNR-01	261	-	0.313
UNR-02	1766	-	0.351
UNR-03	1808	-	0.650

## 2.4 Post-Development: Uncontrolled Flows

For the proposed stormwater management system, there is an uncontrolled flow at the front of the building – i.e. on the surfaces parallel to the streets – as well as on the west and back sides of the property. The total uncontrolled surface is of 3 835 m<sup>2</sup>, and the calculated time of concentration is of 10 minutes. Therefore, the uncontrolled flows for the 100-year storm events are 93.2 L/s. The detailed calculations are described in the annexe C.

The uncontrolled flow will be subtracted to the pre-development flowrate for 5-year event to determine the allowable flowrate for both design recurrence.

## 2.5 Post-Development: Controlled Flows and Storage Requirements

The controlled flow for the developed site as well as the required storage were calculated using the Rational Method. The outflow to the storm sewers will be the subtraction of the 100-year uncontrolled flow to the 5-year pre-development flow, resulting in a flowrate of 72.6 L/s.

The site has been divided in two phases. Initially, the phase 2 will drain toward the phase 1. The predevelopment surfaces will therefore be included in the design. Phase 1 prior to phase 2 being built will have a maximum flowrate of 66.6 L/s, an average flowrate of 33.3 L/s and a total retention requirement of 544.6 m<sup>3</sup>. This is the maximum requirement including the 20% increase for the climate change as required by the city and using the average release rate and a 10% increase to the volume. Once phase 2 is built, phase 1 will only drain itself reducing the required retention volume to 427.2 m<sup>3</sup>. Phase 2 will have its own system with an allowable flowrate of 6.0 L/s, an average flowrate of 3.0 L/s and a total required volume of 285 m<sup>3</sup> for the 100 yr events including a 20% increase for the climate change and a 10% increase to the final volume. The detailed calculations are found in Appendix C.

Table 3: Storage Requirements Phase 1 and 2 using the City of Ottawa IDF Curves

Tc (min)	I <sub>2</sub> (mm/h)	I <sub>5</sub> (mm/h)	I <sub>100</sub> (mm/h)	Q <sub>In-2yr</sub> (L/s)	Q <sub>In-5yr</sub> (L/s)	Q <sub>In-100yr</sub> (L/s)	Q <sub>out</sub> (L/s)	Q <sub>In-out-2yr</sub> (L/s)	Q <sub>In-out-5yr</sub> (L/s)	Q <sub>In-out-100yr</sub> (L/s)	V <sub>5</sub> (m <sup>3</sup> )	V <sub>100</sub> (m <sup>3</sup> )
Phase 1 - Zone 1												
35.0	36.1	48.5	82.6	81.4	109.6	209.5	33.3	48.1	76.3	176.2	<b>160.2</b>	369.9
65.0	23.2	31.0	52.6	52.3	70.1	133.5	33.3	19.0	36.8	100.2	143.6	<b>390.9</b>
Phase 2 - Zone 1												
30.0	40.0	53.9	91.9	76.0	102.3	193.9	33.3	42.7	69.0	160.6	<b>124.2</b>	289.0
55.0	26.2	35.1	59.6	49.7	66.6	125.8	33.3	16.4	33.3	92.5	110.0	<b>305.4</b>
Phase 2 - Zone 2												
145.0	12.6	16.8	28.4	10.4	13.8	26.0	3.0	7.3	10.8	22.9	<b>94.1</b>	199.5
280.0	7.5	10.0	16.8	6.2	8.2	15.4	3.0	3.2	5.2	12.3	87.5	<b>207.5</b>

The required storage will be retained partly on the roof of the proposed building as well as in the storm sewer structures and pipes. The remaining volume will be stored in two underground concrete tanks which will be located along the north and northeast sides of the underground parking as shown on the C-203 drawing (Appendix A). The proposed stormwater storage distribution is shown in Table 4 and 5.

Table 4: Proposed Stormwater Storage for phase 1 prior to phase 2

Description	Parameters	Values	Units
Phase 1	5-year required storage <sup>1</sup>	227	m <sup>3</sup>
	100-year required storage <sup>1,2</sup>	545	m <sup>3</sup>
	Maximum accumulation on roof	150	mm
	Maximum Volume retained on roof	121	m <sup>3</sup>
	Volume retained in underground concrete tank	415	m <sup>3</sup>
	Volume retained in sewer structures and pipes	10	m <sup>3</sup>
	<b>Total storage volume available</b>	<b>546</b>	<b>m<sup>3</sup></b>

Table 5: Proposed Stormwater Storage after phase 2

Description	Parameters	Values	Units
Phase 1	5-year required storage <sup>1</sup>	137	m <sup>3</sup>
	100-year required storage <sup>1,2</sup>	427	m <sup>3</sup>
	Maximum accumulation on roof	150	mm
	Volume retained on roof	121	m <sup>3</sup>
	Volume retained in underground concrete tank	415	m <sup>3</sup>
	Volume retained in sewer structures and pipes	10	m <sup>3</sup>
	<b>Total storage volume available</b>	<b>546</b>	<b>m<sup>3</sup></b>
Phase 2	5-year required storage <sup>1</sup>	104	m <sup>3</sup>
	100-year required storage <sup>1,2</sup>	285	m <sup>3</sup>
	Maximum accumulation on roof	150	mm
	Volume retained on roof	65	m <sup>3</sup>
	Volume retained in underground concrete tank	215	m <sup>3</sup>
	Volume retained in sewer structures and pipes	5	m <sup>3</sup>
	<b>Total storage volume available</b>	<b>285</b>	<b>m<sup>3</sup></b>

1 - A 10% increase was included in the volume requirement as an extra safety measure

2 - A 20% increase to rainfall was included for the climate change effects

3 - To be verified with the mechanical engineer



The following items related to rooftop drainage will need to be completed by the mechanical and structural engineer responsible for the design:

- Flow Control Roof Drainage Declaration See appendix C
- Design of the underground concrete tank. See appendix G.

The roof drains used are the *AJUSTABLE FLOW CONTROL* DRAIN by the company WATTS. The assumptions are that the 6" drains will have a 1/4" exposed opening which will allow 15 gallon/min., see Appendix G.

The Inlet control device (ICD) for phase 1 is an orifice with a circular opening diameter of 150mm and a water head of 1.25m. See appendix C.

The ICD for the phase 2 is a vortex flow regulator model 100 VHV-1 by the company John Meunier. The water head is 1.00m. See appendix C and G. Both ICD will have an overflow, see plans for more details.

## 2.6 Stormwater Quality

Low Impact Development (LID) Best Management Practices (BMPs) should be used wherever possible as part of the proposed development. LID measures such as bioretention, permeable pavement, tree conservation and green roofs are intended to address water quality and quantity concerns. Many of these measures can't be provided for this project due to development requirements and site constraints.

As mentioned by the MVCA (see Appendix B), the runoff from the site drains towards the KTC-SWMF which provides 70% TSS removal. This facility was designed taking into consideration future needs as described in the KTC – CBD SWM report (see Appendix B) prepared by J.L. Richards & Associates Limited. The proposed site is in Zone 8 within the catchment area of the KTC-SWMF (see Appendix B). The following design criteria were applied when sizing the stormwater management facility:

- 70% TSS removal
- 130m<sup>3</sup>/ha water quality storage volume including:
  - 90m<sup>3</sup>/ha permanent pool volume
  - 40m<sup>3</sup>/ha extended detention storage

As mentioned in the *Technical Memo*, the controlled flows from the site are tributary to the Kanata Town Centre Stormwater Management Facility (KTC-SWMF), which is anticipated to

provide the quality control for the site runoff. All other flows, such as the roof runoff and uncontrolled flows require no treatment considering no vehicular traffic is anticipated in these areas.

The MVCA requires the project to provide additional TSS removal to reach 80% removal once the water exit the KTC-SWMF. This represents a removal on site of at least 33% of the TSS based on the following calculation:

$$\begin{aligned} 100\% \times (\text{site removal}) \times (\text{KTC-SWMF removal}) &= \text{target removal} \\ 1 * (1 - x) * (1 - 0.70) &= (1 - 0.80) \\ x &= 0.33 \end{aligned}$$

This percentage can be achieved through standard methods used on site. There are sediment traps installed inside multiple structures. Those have a depth of 300mm for the catch-basin and the concrete retention tanks and 450mm for the manhole containing the inlet control device (ICD) which remove a fair amount of TSS.

The main source of TSS will also be reduced sufficiently at the source by a proper seasonal maintenance of the site. Based on a research paper by the Desert Research Institute (DRI), street sweeping has shown to reduce the fine sediment in stormwater by 50% which is more than the on-site requirement by the MVCA. (Brown, Susfalk, Fellers, & Fitzgerald, 2011)

## 2.7 Erosion and Sediment Control

Prior to, during and after construction, the following erosion and sediment control measures should be implemented to avoid the sediment transfer to existing streams and storm sewer systems. These measures are listed on the drawing C-202 in Appendix A.

### Pre-Construction

- Installation of a silt fence (geotextile)
- Installation of inserts inside all existing manholes adjacent to construction zone
- Control measures to be inspected once installed
- Installation of a mud mat at the site access point

### Construction

- Minimize the extent of disturbed areas
- Protect disturbed areas of runoff
- Provide cover if disturbed areas will not be reinstated within a reasonable period.
- Inspect silt fence regularly during construction. Clean and repair, as required.
- Control dust during construction

After Construction

- Provide permanent cover to disturbed areas (i.e. topsoil and seed)
- Remove all temporary erosion and sediment control items (silt fence and filter cloths) once disturbed areas have been reinstated

Inspections

- Erosion and sediment control measures will be inspected upon completion
- Control measures are to be inspected weekly

All control measures are to be inspected once installed as well as during construction.

**2.8 Infiltration**

As the Carp River Watershed/Subwatershed Study (2004), the infiltration target for the site is established as a minimum of 73mm/yr.

Based on data from the city, the total average precipitation in the last three years was 900.3 mm/yr. This is the precipitation intensity falling on the whole site. Since a large portion of this precipitation fall on impermeable surfaces, only a small portion of this intensity will be infiltrated naturally. The rational method is commonly used to calculate the runoff going to the stormwater system. That same approach can also be used in order to calculate the amount of water not going to the stormwater system.

For this calculation, it will be assumed that only the water falling on permeable surfaces and that isn't part of the runoff will be infiltrated.

The formula could be described as:

$$\text{Infiltration} = I \times A_p \times (1 - C)$$

*Where:*

*I = Total annual precipitation (mm/yr)*

*A<sub>p</sub> = Permeable Area (%)*

*C = Runoff coefficient*

Table 6: Annual Precipitation for Kanata

Year	Annual Precipitation (mm/yr)
2022	978
2021	836.3
2020	886.6
<b>Avg.</b>	<b>900.3</b>

Ref. : [ottawa.weatherstats.ca/charts/precipitation-yearly.html](http://ottawa.weatherstats.ca/charts/precipitation-yearly.html)

Table 7: Project Data

Type of surface	Total area (m <sup>2</sup> )	Percentage (%)	Runoff coefficient
Impermeable	11803	79.2	0.90
Permeable	3093	20.8	0.25

$$\text{Infiltration} = 900.3 \frac{\text{mm}}{\text{yr}} \times 20.8\% \times (1 - 0.25)$$

$$\text{Infiltration} = 140.4 \text{ mm/yr}$$

Since this Infiltration rate is larger than the city requirement, no additional infiltration measures will be required.

### 3.0 SANITARY SEWER DESIGN FLOWS

The proposed sanitary sewer service connections for the new building are 250 mm in diameter and made of PVC. The pipes will be connected on the new street between the project and the 180 Kanata Avenue for the phase 1 and on the existing 825 mm diameter municipal sewer pipe on Maritime Way for the phase 2.

The proposed sanitary system is designed in accordance with the City of Ottawa's Sewer Design Guidelines. The calculations for the proposed development flows are shown in the following sections.

#### 3.1 Population Density

The population density of the proposed development is calculated using the number and type of housing units within this development. The detailed calculations are shown in Table 8 and 9 below and in the Appendix D.

Table 8: Population Density Calculation for Phase 1

Unit Types	Number of Units	Persons Per Unit	Population Density
1-bedroom	149	1.4	208.6
2-bedroom	71	2.1	149.1
3-bedroom	16	3.1	49.6
<i>Total</i>			407

Table 9: Population Density Calculation for Phase 2

Unit Types	Number of Units	Persons Per Unit	Population Density
1-bedroom	83	1.4	116.2
2-bedroom	68	2.1	142.8
3-bedroom	14	3.1	43.4
<i>Total</i>			302

Using the values in Table 4.2 of the Sewer Design Guidelines for per unit populations, the population densities of the proposed development are found to be 407 persons for the phase 1 and 302 persons for the phase 2. These values will be used in the following sections to determine the sewer design flows.

### 3.2 Average Wastewater Flows and Peaking Factors

The average wastewater flow for residential developments of 280 L/c/d is used to determine the average day demand for residential use. The new building will also include 1,214 m<sup>2</sup> of commercial areas in the phase 1 of the construction. According to the Sewer Design Guidelines, the average wastewater flow for commercial use is of 28,000 L/gross ha/d. Using this information, the total average wastewater flow for the proposed development is calculated below.

#### Phase 1:

Average wastewater flow per capita for residential use: 280 L/c/d

Average wastewater flow for residential use: 114 044 L/d

Average wastewater flow for commercial use: 28,000 L/gross ha/d

Commercial areas: 1 214m<sup>2</sup> 3 399 L/d

The Harmon equation is then used to calculate the residential peak factor. Moreover, a peak factor of 1.50 is used for commercial areas.

$$P.F. = 1 + \left( \frac{14}{4 + \left( \frac{P}{1000} \right)^{1/2}} \right) \times K, \quad \text{where } K = 1$$

Hence, the peak factor for residential use is of 4.02.

Phase 2:

Average wastewater flow for residential use: 84 672 L/d

The Harmon equation is then used to calculate the residential peak factor.  
Hence, the peak factor for residential use is of 4.08.

**3.3 Extraneous Flows**

In accordance with Article 4.4.1.4 of the Sewer Design Guidelines, an allowance for flows from extraneous sources must be considered in the calculation of the peak design flow.

The average infiltration allowance is of 0.33 L/s/gross ha for wet-weather inflow into the manholes and pipes. Therefore, with a total site area of 1.490 ha, the infiltration flow is 0.49 L/s.

**3.4 Total Sanitary Sewer Design Flow**

Combining the results from the above calculations, the total sanitary sewer design flow is calculated as follows:

Phase 1:

$$Q_{design} = [(4.02 \times 114\,044 \text{ L/d}) + (1.50 \times 3\,399 \text{ L/d})] \times \frac{1}{86\,400 \text{ sec/d}} + 0.49 \text{ L/s}$$

$$Q_{design} = 5.85 \text{ L/s}$$

Phase 2:

$$Q_{design} = [(4.08 \times 87\,672 \text{ L/d})] \times \frac{1}{86\,400 \text{ sec/d}}$$

$$Q_{design} = 4.00 \text{ L/s}$$

The summary of this calculation is shown in Appendix D.

**4.0 DOMESTIC WATER DEMAND**

The proposed water service connection for the new building is 200 mm in diameter and made of PVC. This pipe will be connected to the existing 600 mm diameter municipal watermain on Maritime Way. A shutoff valve will be installed at the property line as per the City guidelines.

Moreover, the watermain will be looped and connected at the service entry to the building. An isolation valve will be installed between the two water service connections.

The proposed water system is designed in accordance with the City of Ottawa's Design Guidelines for water distribution. The calculations for the proposed water demand are shown in the following sections.

We can determine the average day demand for the proposed development using the values found in Table 4.2 of the Design Guidelines as the population density of the development was determined to be 704 people in Section 2.1. Hence, average day demands of 280 L/c/d and 28,000 L/gross ha/d are used for the residential and commercial spaces, respectively.

Average day demand per capita for residential use:	280 L/c/d
Average day demand for residential use:	197 232 L/d
Average day demand for other commercial use:	28,000 L/gross ha/d
Commercial Area: 1 214 m <sup>2</sup>	3 399 L/d

Therefore, the total average day demand is:

$$Q_{avg,day} = \left(197\,232 \frac{L}{d} + 3\,399 L/d\right) \times \frac{1}{86,400} sec/d = 2.32 L/s$$

The maximum daily demand and the maximum hour demand are calculated using the factors found in Table 4.2 of the Design Guidelines.

$$Q_{max,day} = \left(2.5 \times 197\,232 \frac{L}{d} + 1.5 \times 3\,399 L/d\right) \times \frac{1}{86,400} sec/d = 5.77 L/s$$

$$Q_{max,hr} = \left(2.2 \times 2.5 \times 197\,232 \frac{L}{d} + 1.8 \times 1.5 \times 3\,399 L/d\right) \times \frac{1}{86,400} sec/d$$

$$Q_{max,hr} = 12.66 L/s$$

The detailed calculations for domestic water demand are found in Appendix E.

#### 4.1 Boundary Conditions

This section presents the existing boundary conditions for the water distribution system for the connection sites identified in the figure below, as provided by the City of Ottawa. Note, this information is based on current operation of the city's water distribution system.

Figure 03: Service connection locations for the water distribution system (City of Ottawa)



Table 10: Connection 1 Located on Maritime Way (City of Ottawa)

Demand Scenario	Head (m)	Pressure (psi)
Maximum HGL	161.3	88.6
Peak Hour	156.4	81.6
Max Day + Fire Demand	156.2	81.4

*Ground elevation at 98.9 m*

The pressure at the first-floor elevation after the exterior pressure losses due to friction and height will be 70.44 psi. See Appendix E for detailed calculations.

It must be noted that the static pressure at any fixture shall not exceed 552 kPa (80 psi) according to the Ontario Building Code for areas that may be occupied. Hence, the following pressure control measures shall be considered:

1. If possible, the systems are to be designed to residual pressures 345 to 552 kPa (50 to 80 psi) for all occupied areas outside of the public right-of-way without special pressure control equipment.
2. Pressure reducing valves are to be installed immediately downstream of the isolation valve in the building, located downstream of the meter so that it is maintained by the owner.

These pressure control measures are presented in order of preference.



## 5.0 REQUIRED FIRE DEMAND

The flow rates required for fire protection vary according to the zoning, the type of units, the fire resistivity of the construction materials, the ground floor area as well as many other factors. The method described in *Water Supply for Public Fire Protection*, written by the Fire Underwriters Survey (FUS) (2020) is used to estimate the fire demand required for fire protection, as per the City Guidelines.

Essentially, the required flow rate (F), expressed in liters per minute, is calculated based on the floor area of the building (A) in square meters and the type of construction (C), using the following equation.

$$F = 220 \times C\sqrt{A}$$

The value of C used is 0.8 for a non-combustible construction. According to the FUS, a non-combustible construction is "any structure having all structural members including walls, columns, piers, beams, girders, trusses, floors and roofs made of non-combustible material and not qualifying as fire-resistive construction." In this case, the building will be full non-combustible construction both for the construction type and exterior cladding.

The value of A represents the gross floor area of the building, that is, the sum of the surface area of all floors. See in the table below that surface area of each floor. The effective area is to be calculated as per the 2020 regulations for the Water Supply for Public Fire Protection in Canada, the total effective area is to be calculated as the largest floor with the addition of 25% of the next 2 adjacent floors.

Table 11: Gross Floor Area for the Proposed Development

Floor	Surface Area Per Floor (m <sup>2</sup> )	Number of Floors	Floor Area (m <sup>2</sup> )
Ground Floor	5 106	1	5 106
Levels 2-3	4 386	2	2 193
Levels 4-7	3 958	4	0
Levels 8-9	3 442	2	0
Level 10-11	1 337	2	0
<i>Total</i>			7299

Finally, according to the FUS method, certain reductions and increases may be applied depending on a variety of factors such as the combustibility of the occupying materials or furniture, the presence of automatic sprinklers systems as well as the development's distance from neighbouring buildings. For example, for buildings protected by automatic sprinklers designed in accordance with the NPFA 13, the flow rate required for fire protection,  $F$ , can be reduced by 50%.

Using this method, the total fire demand was determined to be 7 000 L/min. Moreover, for a duration of water supply of 2 hours, the required volume of water is 840 m<sup>3</sup>. The details of the fire flow calculations are shown in the Appendix F.

## 6.0 REFERENCES

Brown, S., Susfalk, R., Fellers, D., & Fitzgerald, B. (2011). Effectiveness of Street Sweeping in Incline Village, NV. *Nevada Tahoe Conservation District*.

# **APPENDIX A**

Civil Engineering Plans

# APPENDIX B

## Background Documents:

Land Survey by Annis, O'Sullivan, Vollebakk Ltd. on April 13, 2021

Excerpts from Stormwater Management Report for Kanata Town Centre by J.L. Richards & Associates Limited dated January 1999

MVCA Correspondence dated February 4<sup>th</sup>, 2022

MVCA Comment Letter dated December 22<sup>nd</sup>, 2021

Canadian Shield Roadway Coordination

PART OF LOTS 2 AND 3  
CONCESSION 2  
GEOGRAPHIC TOWNSHIP OF MARCH  
CITY OF OTTAWA  
Prepared by Annis, O'Sullivan, Vollebek Ltd.

**Surveyor's Certificate**  
I CERTIFY THAT  
1. This survey and plan are correct and in accordance with the Survey Act and the Surveyors Act and the regulations made under them.  
2. The survey was completed on the 13th day of April, 2021.

Date: \_\_\_\_\_  
T. Harbeck  
Ontario Land Surveyor

Scale 1:250  
0 5 10 Metres

Metric  
DISTANCES SHOWN ON THIS PLAN ARE IN METRES AND CAN BE CONVERTED TO FEET BY DIVIDING BY 0.3048

**Notes & Legend**

Denotes	
—+—	Survey Monument Planted
—+—	Survey Monument Found
—+—	Standard Iron Bar
SSIB	Short Standard Iron Bar
IB	Iron Bar
RP	Rock Post
NT	Non-Tangential
(WT)	Witness
Mes.	Measured
(AOG)	Annis, O'Sullivan, Vollebek Ltd.
(P)	Plan 4R-9182
(P3)	Plan 4R-16146
(P4)	Plan 4R-31544
(T)	Deciduous Tree
(C)	Coniferous Tree
(FH)	Fire Hydrant
(WV)	Water Valve
(M-S)	Maintenance Hole (Storm Sewer)
(M-S)	Maintenance Hole (Sanitary)
(M-T)	Maintenance Hole (Bell Telephone)
(M-T)	Maintenance Hole (Traffic)
(M-H)	Maintenance Hole (Hydro)
(T-C)	Cable Terminal Box
(VC)	Valve Chamber (Watermain)
(ST)	Underground Storm Sewer
(S)	Underground Sanitary Sewer
(CB)	Catch Basin
(S)	Sign
(UP)	Utility Pole
(AN)	Anchor
(LS)	Light Standard
(D)	Diameter
(E)	Location of Elevations
(E)	Top of Concrete Curb Elevation
(C/L)	Centreline
(P)	Property Line
(CP)	Concrete Pipe
(T/P)	Top of Pipe

Bearings hereon are grid bearings referred to the northerly limit of Kanata Avenue having a bearing of N84°02'15"E and are referenced to Specified Control Points 01919680037 and 01919791051, MTM Zone 9 (76°30' West Longitude) NAD-83 (original).

**ELEVATION NOTES**  
1. Elevations shown are geodetic and are referred to the CGVD28 geodetic datum.  
2. It is the responsibility of the user of this information to verify that the job benchmark has not been altered or disturbed and that its relative elevation and description agrees with the information shown on this drawing.

**UTILITY NOTES**  
1. This drawing cannot be accepted as acknowledging all of the utilities and it will be the responsibility of the user to contact the respective utility authorities for confirmation.  
2. Only visible surface utilities were located.  
3. A field location of underground plant by the pertinent utility authority is mandatory before any work involving breaking ground, probing, excavating, etc.

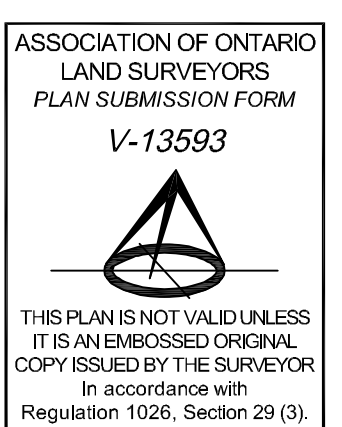

**STORMWATER MANAGEMENT REPORT**

**KANATA TOWN CENTRE  
CENTRAL BUSINESS DISTRICT**

**VOLUME 1 OF 2**

January, 1999

Prepared for:

**URBANDALE CORPORATION**  
2193 Arch Street  
Ottawa, ON K1G 2H5

Prepared by:

**J.L. RICHARDS & ASSOCIATES LIMITED**  
Consulting Engineers, Architects & Planners  
864 Lady Ellen Place  
Ottawa, ON K1Z 5M2

JLR 15712

#### 4.0 PROPOSED STORMWATER MANAGEMENT FACILITY

##### 4.1 General

Urbanization of the lands referred as the Kanata Town Centre - Central Business District will change the hydrological regime of Watts Creek. The potential impacts associated with urban runoff arise primarily from the amount of urban area that is impervious to rain and snowmelt water. These impervious urban surfaces increase the amount of surface runoff that is generated and is conveyed more efficiently to the receiving stream via a storm sewer system. Furthermore, direct runoff from urban areas is known to carry a range of potentially undesirable compounds such as high loadings of suspended solids, heavy metals, nutrient compounds etc. To mitigate these potential impacts, the 1993 Master Drainage Study, has formulated alternatives to address these concerns. The 1993 study concluded that two detention facilities (incorporating both quality and quantity controls) is the preferred option to meet the current water quality and quantity guidelines and, at the same time, protect Watts Creek's existing environmental features. In 1996-1997, the first SWMF was constructed to service Phase 1 residential lands. With the beginning of development of the Kanata Town Centre - Central Business District in 1998 and with additional development scheduled in 1999 (Hotel Site), the need for a storm sewer outlet was required. In general, the second SWMF was designed following the same overall concept outlined in the 1993 Master Drainage Study and to meet current water quality guidelines.

##### 4.2 Stormwater Management Sizing

The water quality treatment of the proposed SWMF has been designed based on Table 4.1 of the MOEE Stormwater Manual entitled "Stormwater Management Practices Planning and Design Manual, page 173, (MOEE, June 1994)". This table recommends that for a wet pond with a protection level 2 (this type of protection includes feeding areas particularly for adult fish, areas of unspecialized spawning habitat and pool-riffle-run complexes that occur along much of a watercourse), a water quality storage volume of 130 m<sup>3</sup>/ha is required for a TSS removal of 70% of a tributary area having an average imperviousness of 70%. Furthermore, this table recommends that 40 m<sup>3</sup>/ha be used as extended detention storage and the remaining i.e. 90 m<sup>3</sup>/ha, be used as permanent pool volume. To determine the required volume for both the permanent pool and the extended detention storage, a table showing all tributary areas to the proposed stormwater management facility was developed (refer to

Appendix 'H' for table). This table shows that 61.24 ha of contributing area will be serviced by the future SWMF. The average total imperviousness for these contributing areas was found to be 74%. Based on the information presented in this table (refer to Appendix 'H'), the MOEE design manual therefore recommends that a permanent pool volume of 5512 m<sup>3</sup> and an extended storage volume of 2450 m<sup>3</sup> be provided to achieve the required treatment for a protection level 2 (i.e. TSS removal of 70%).

#### 4.2.1 SWMF Design Rationale

The length to width ratio for the proposed SWMF is approximately 5 to 1 which exceeds the 3 to 1 length to width ratio recommended in the "Stormwater Management Practices Planning and Design Manual, page 76, (MOEE, June 1994)". This manual also recommends that a minimum of 24 hour drawdown time be used to minimize the possibility of short-circuiting and hence maximizing the performance of the facility. To minimize the risk of short-circuiting and maximize the TSS removal, the outlet structure of the SWMF was designed using a 48 hour drawdown time (refer to Section 4.3 for additional information). Using this outlet configuration (i.e. 48 hour drawdown time), the maximum outflow rate at elevation 90.20 m (i.e. maximum elevation of the extended detention storage) is 0.028 m<sup>3</sup>/s. With this type of restricted outflow rate and with storm inflow to the SWMF of approximately 2.83 m<sup>3</sup>/s (total flow to facility generated by a 4 hour - 25 mm Chicago design storm event), it is expected that this configuration will eliminate any possibility of short-circuiting.

The length to width ratio for the sedimentation forebay is approximately 3 to 1 which exceeds the 2 to 1 ratio recommended in the "Stormwater Management Practices Planning and Design Manual, page 89, (MOEE, June 1994)".



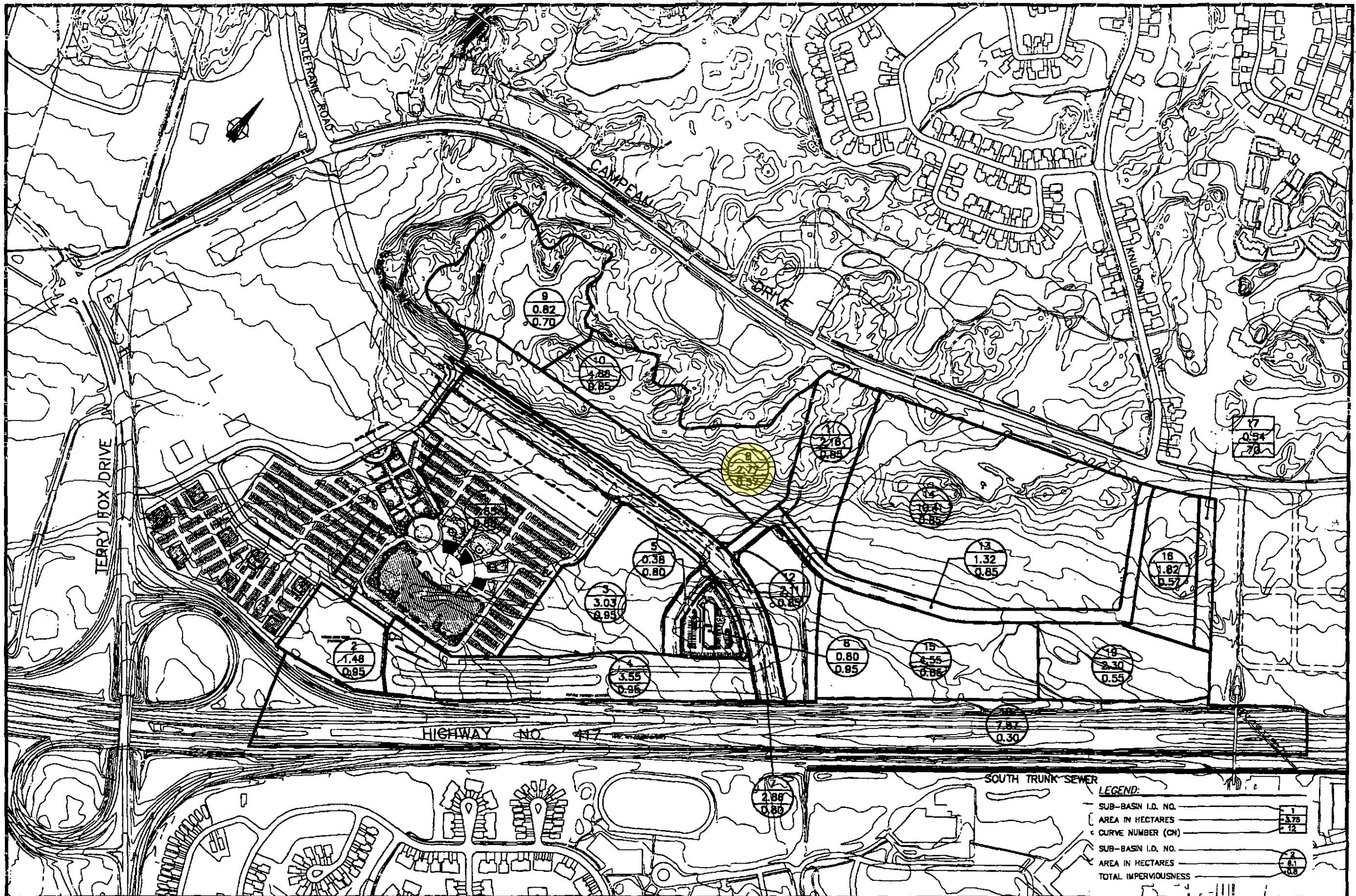

NO.	DATE	REVISIONS	BY	NO.	DATE	REVISIONS	BY

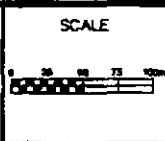

**J.L. Richards & Associates Limited**  
 Consulting Engineers, Architect & Planners  
 OTTAWA, KINGSTON, SUDBURY, CANADA

DESIGN C.F.  
 CHECKED C.F.  
 DRAWN T.L.O.B.  
 CHECKED  
 APPROVED

**CITY OF KANATA**  
 DEPARTMENT OF ENGINEERING  
 AND PUBLIC WORKS

**URBANDALE CORPORATION**

**KANATA TOWN CENTRE  
 FUTURE CONDITIONS**

DATE: JANUARY 1999  
 DRAWN BY: [Signature]  
**FIGURE 3**

**LEGEND:**

—	SUB-BASIN I.D. NO.	1
[ ]	AREA IN HECTARES	3.75
( )	CURVE NUMBER (CN)	12
—	SUB-BASIN I.D. NO.	2
[ ]	AREA IN HECTARES	8.1
( )	TOTAL IMPERVIOUSNESS	0.8

JLR 15712

Kanata Town Centre - Central Business District

Tributary Subwatersheds to Proposed Stormwater Management Facility

QUALHYMO LUMPED AREA No.	OTTHYMO AREA No.	Description	Area (ha)	TIMP	On-Site Storage	Description of Storage	IMP areas (ha)
1	1	AMC Site	7.85	0.85	entirely *	up to 100 yr	6.67
	2	Park & Ride	1.46	0.95	none		1.39
	3	Phase IV	3.03	0.95	entirely	up to 100 yr	2.88
	4	Transitway	3.55	0.95	none		3.37
	5	Hotel Road	0.38	0.80	none		0.30
	6	Hotel Site	0.80	0.95	entirely	up to 100 yr	0.76
2	7	Castlefrank Road	2.84	0.80	none		2.27
	8	Adjacent Lands	2.77	0.57	none		1.58
	9	Exist Pond **	0.82	---	entirely	up to 100 yr	0.00
	10	Kanata North	4.66	0.85	none		3.96
	11	Adj Lands (east)	2.16	0.85	none		1.84
	12	Adj Lands (south-east)	2.11	0.85	entirely	up to 100 yr	1.79
3	13	Street "A"	1.32	0.85	Limited	up to 10 yr	1.12
	14	Urbandale North	10.41	0.85	Limited	up to 10 yr	8.85
	15	Urbandale South	4.48	0.85	entirely	up to 100 yr	3.81
	16	Urbandale East	1.82	0.57	Limited	up to 10 yr	1.04
	17	Urbandale East (park)	0.54	---	none		0.00
	18	Queensway	7.87	0.30	none		2.36
	19A	SWMF	0.95	0.99	none		0.94
19B	SWMF	1.42	0.20	none		0.28	
		TOTAL	61.24				45.22
						Avg. TIMP =	0.74

\*: Overflow of 13 l/s @ 1:100 year storm event

\*\* : Peak flows from this area is to be restricted to 10 year based on Rc=0.2 (from CCL)

**De:** Erica Ogden <eogden@mvc.on.ca>  
**Envoyé:** 4 février 2022 16:22  
**À:** Lauren Menard  
**Cc:** Benoit Bray; Olivier Morrissey  
**Objet:** RE: Kanata Avenue - Quality Control Requirements  
**Pièces jointes:** [150 Kanata Ave - MVCA Comment Letter - Dec 22 2021.pdf](#)

**Indicateur de suivi:** Assurer un suivi  
**État de l'indicateur:** Avec indicateur

Hello Lauren,

Thank you for your e-mail. I apologize when we spoke on the phone, I hadn't realized that you were looking to discuss an application which MVCA has already reviewed a submission and provided comments on.

In case you haven't yet received them from the City, I have attached a copy of our comments from December 22, 2021.

The water quality target for this site is an enhanced level of treatment, 80% TSS removal. It is noted that the Kanata Town Centre- Stormwater Management Facility, to which the runoff from the site drains, was designed to provide only 70% TSS removal. Please explore whether BMPs/LIDs could be implemented on site to provide additional water quality treatment.

The Carp River Watershed Subwatershed Study identifies the subject site as a low groundwater recharge area, which has an annual infiltration target of 73mm/year.

If you have any other questions, I would be happy to set up a time to discuss with you.

Thank you,

**Erica C. Ogden, MCIP, RPP | Environmental Planner | Mississippi Valley Conservation Authority**  
10970 Highway 7, Carleton Place, ON K7C 3P1  
[www.mvc.on.ca](http://www.mvc.on.ca) | c. 613 451 0463 | o. 613 253 0006 ext. 229 | [eogden@mvc.on.ca](mailto:eogden@mvc.on.ca)

---

**From:** Lauren Menard <[lménard@equipelaurence.ca](mailto:lménard@equipelaurence.ca)>  
**Sent:** February 2, 2022 3:05 PM  
**To:** Erica Ogden <[eogden@mvc.on.ca](mailto:eogden@mvc.on.ca)>  
**Cc:** Benoit Bray <[bbray@equipelaurence.ca](mailto:bbray@equipelaurence.ca)>; Olivier Morrissey <[omorrissey@equipelaurence.ca](mailto:omorrissey@equipelaurence.ca)>  
**Subject:** Kanata Avenue - Quality Control Requirements

Hi Erica,

As mentioned over the phone, we are a Civil Engineering firm based out of Quebec currently working on a project located at the intersection of Kanata Avenue and Maritime Way. See site location below.

The site is roughly 1.6 ha.

In terms of stormwater management, what would be the quality control requirements as well as the infiltration targets for this site?

Please let me know if you require any additional information.



Regards,



**LAUREN MENARD** CPI

20845, ch. de la Côte-Nord, bureau 204, Boisbriand (Qc) J7E 4H5

T 450 970-3100 p.271 | C 514 503-3495

[lménard@equipelaurence.ca](mailto:lménard@equipelaurence.ca) | [equipelaurence.ca](http://equipelaurence.ca)

[Piedmont](#) | [Boisbriand](#) | [Joliette](#) | [Montréal](#) | [Mont-Laurier](#) | [Gatineau](#)

Rejoins notre équipe de professionnels passionnés!  
➔ **ENVOIE TON CV**

# Conservation Partners Partenaires de conservation

---



File: PMRSP-31 & PMRZA-38

December 22, 2021

Lisa Stern  
Development Review Planner  
Planning, Infrastructure and Economic Development  
City of Ottawa  
110 Laurier Avenue West, 4th Floor  
Ottawa, ON K1P 1J1

Dear Ms. Stern:

**Re: Application for Site Plan Control and Zoning By-law Amendment – D07-12-21-0153 & D02-02-21-0109  
150 Kanata Avenue, City of Ottawa (March)**

---

The staff of Mississippi Valley Conservation Authority (MVCA) has reviewed the above noted application for concerns related to natural heritage and natural hazards for the subject property and surrounding lands. The scope of the natural heritage review includes wetlands, watercourses and significant valleylands, while the focus of the natural hazards review includes flood plain, unstable slopes and unstable soils.

The following comments are offered for your consideration:

## **Summary of Proposal**

A Zoning By-law Amendment and Site Plan Control applications have been submitted for the development of a mixed use building with seven, nine and 11-storey components that wraps around the corner of Kanata Avenue and Maritime Way. The building is comprised of approximately 351 residential units and 820 m<sup>2</sup> of commercial and office space. Access is proposed to be taken from Maritime Way. A total of 445 parking spaces are proposed both at grade and underground. The applicant is seeking relief from the requirements of the Zoning Bylaw as follows:

- Increase the maximum required rear yard setback; and
- Reduce required non-residential space provided.

## **Property Overview**

The subject site is located on the north side of Kanata Avenue west of Maritime Way, south of Bill Teron Park and north of the shopping centre. The subject site makes up a portion of a larger piece of land owned by the City which consists of public parkland and lands intended for future development. The site is currently vacant and densely vegetated. The subject site is zoned MC2 H28 (Mixed-Use Centre Zone, subzone 2) and MC5 H35 (Mixed-Use Centre Zone, subzone 5) pursuant to Zoning By-law 2008-250.

## **Natural Heritage**

MVCA staff have been circulated the following in support of the development:

- “Bill Teron Park Expansion and Future Development Lands, Environmental Impact Statement and Tree Conservation Report” by Stantec, February 21, 2020.
- “Landscape Details, Kanata Town Centre (Parcels 2 & 3) Kanata Ave/Maritime Way” by Lames B. Lennox and Associates Inc., September 27, 2021.
- “Site Plan, Kanata Town Centre (Parcels 2 & 3) Kanata Ave/Maritime Way” by Emd Batimo, September 22, 2021.

MVCA concurs with the methods and recommended mitigation measures within the EIS, however the EIS submitted was not site specific and did not discuss the site-specific impacts of the proposed development at 150 Kanata Ave. MVCA identifies no natural heritage features within the scope of our review, associated with the subject lands.

## **Natural Hazards**

Available soils mapping indicates there is a potential for organic soils to be associated with the subject lands. Organic soils can be a concern as they lack structure and compress so much they usually cannot support structures. MVCA notes that a Geotechnical Investigation has been completed for the proposed development which notes that topsoil and deleterious fill containing organic material should be stripped from under any buildings, paved areas and other settlement sensitive structures. MVCA identifies no other natural hazards within the scope of our review, associated with the subject lands.

## **Stormwater Management**

MVCA staff has reviewed the following reports, with a focus on the stormwater quantity and quality management:

- Stormwater Management Report Lib Kanata, Ottawa, by Equipe Laurence Inc., September, 2021.
- Geotechnical Investigation – Proposed Mixed-Use Development, Parcels 2 and 3 of 6301 Campeau Drive, by Pinchin, July 22, 2021

The predevelopment overland flow was calculated to be 109.2 L/s and 234.0 L/s for the 5-yr and 100-yr storm, respectively. Post development flows will be restricted to the 5-yr storm up to and including the 100-yr storm plus 20%. The runoff coefficients for the 100-yr storm were increased by 25%. Excess water will be stored on the roof and in an underground storage tank.

MVCA offers the following comments for your consideration:

- i) Please include the specifications, details and location of the underground storage tank.
  - ii) Please include roof drain specifications, details and locations.
  - iii) Please include all ponding depths for the 100-yr storm.
  - iv) The Pinchin Geotechnical Investigation identified sand in the northern and western quadrants of the site. Please consider low impact development techniques as part of the design.
- i) Section 5.0 Stormwater Quality notes that “*controlled flows from the site are tributary to the Kanata Town Centre Stormwater Management Facility, which is anticipated to provide the quality control for the site runoff*”. Please include excerpts from the governing reports demonstrating the required capacity and water quality treatment for the site.
  - ii) Section 6.0 Erosion and Sediment Control notes that filter cloth will be installed over all existing

manholes. Please use catch basin inserts or a demonstrated equivalent. The Erosion and Sediment Control Plan should indicate the location of all catch basin inserts at all catch basins, catch basin manholes, and storm manholes.

- iii) Please include the installation of a mud mat under Section 6.0 Erosion and Sediment Control and include the location and detail in the erosion and sediment control plan.
- iv) Please include information on dewatering under Section 6.0 Erosion and Sediment Control such as the use of filter socks and/or dewatering traps.

**Conclusion**

MVCA does not object to Zoning By-law Amendment application D02-02-21-0109, as currently proposed.

MVCA recommends that the above noted stormwater management comments be addressed prior to proceeding with the Site Plan Control application D07-12-21-0153.

Thank you for the opportunity to review and comment. Please advise us of the decision in this matter.

Please contact the undersigned with any questions that may arise.

Regards,

A handwritten signature in dark ink that reads "Erica C Ogden". The signature is written in a cursive, flowing style.

Erica C. Ogden, MCIP, RPP  
Environmental Planner

**De:** Calum MacDonald <c.macdonald@mcintoshperry.com>  
**Envoyé:** 15 septembre 2022 10:28  
**À:** Francis Lacroix  
**Cc:** Benoit Bray; Julien Levesque  
**Objet:** RE: Canadian Shield Roadway coordination  
**Pièces jointes:** [Canadian Shield Extension.pdf](#)

Hi Francis,

My apologies for the delay. I will send you the draft plans here shortly. As you mentioned below, they are only functional design plans and are not yet approved by the City.

I had a review of the grading plans you sent me and as of now the access onto Canadian Shield is about 0.8m higher than the proposed road (see attached). It looks like the entrance can still tie into the road if another low point/cb is added however I'm sure there are larger implications for your site grading/building elevations, etc.

The City is considering a few different options for the road extension right now so there could be an opportunity to try and adjust the road slightly to compliment the site grading.

Please see attached plan/cross-section at the entrance for your reference.

Do you want the functional design plans for the extension in Microstation or CAD?

Thanks Francis, feel free to give me a call to discuss further.

Regards,

Calum

**Calum MacDonald, P.Eng.**

**Technical Lead, Municipal Engineering**

T. 613.778.8609 | C. 613.809.5515

[c.macdonald@mcintoshperry.com](mailto:c.macdonald@mcintoshperry.com) | [www.mcintoshperry.com](http://www.mcintoshperry.com)

**McINTOSH PERRY**

*Turning Possibilities Into Reality*

---

Confidentiality Notice – If this email wasn't intended for you, please return or delete it. Click [here](#) to read all of the legal language around this concept.



Platinum  
member

---

**From:** Francis Lacroix <[flacroix@equipelaurence.ca](mailto:flacroix@equipelaurence.ca)>

**Sent:** September 15, 2022 10:03 AM



**To:** Calum MacDonald <[c.macdonald@mcintoshperry.com](mailto:c.macdonald@mcintoshperry.com)>  
**Cc:** Benoit Bray <[bbray@equipelaurence.ca](mailto:bbray@equipelaurence.ca)>; Julien Levesque <[jlevesque@equipelaurence.ca](mailto:jlevesque@equipelaurence.ca)>  
**Subject:** RE: Canadian Shield Roadway coordination

You don't often get email from [flacroix@equipelaurence.ca](mailto:flacroix@equipelaurence.ca). [Learn why this is important](#)

Hi Calum,

Just a follow up about the requested plans. Would it be possible for you to send us a plan this week?

It doesn't need to be the final plans, just something we can use for coordination.

Thank you,



**FRANCIS LACROIX** CPI

160, boulevard de l'Hôpital, unité 205, Gatineau (Qc) J8T 8J1

T 819 303-2700 p.703 | C 819 431-9582

[flacroix@equipelaurence.ca](mailto:flacroix@equipelaurence.ca) | [equipelaurence.ca](http://equipelaurence.ca)

[Sainte-Adèle](#) | [Boisbriand](#) | [Joliette](#) | [Mont-Laurier](#) | [Gatineau](#) | [Sorel-Tracy](#)

**De :** Francis Lacroix

**Envoyé :** 12 septembre 2022 16:16

**À :** 'Calum MacDonald' <[c.macdonald@mcintoshperry.com](mailto:c.macdonald@mcintoshperry.com)>

**Cc :** Benoit Bray <[bbray@equipelaurence.ca](mailto:bbray@equipelaurence.ca)>; Julien Levesque <[jlevesque@equipelaurence.ca](mailto:jlevesque@equipelaurence.ca)>

**Objet :** RE: Canadian Shield Roadway coordination

Hi Calum,

Here are our latest plans we sent the city.

We are planning the service connections on Maritime Way therefore it should not affect your project.

We need you plans mostly for the grading. We did some temporary hypothesis for the roadway elevations that we need to correct with the right information.

Thank you for the quick response.



**FRANCIS LACROIX** CPI

160, boulevard de l'Hôpital, unité 205, Gatineau (Qc) J8T 8J1  
T 819 303-2700 p.703 | C 819 431-9582

[flacroix@equipelaurence.ca](mailto:flacroix@equipelaurence.ca) | [equipelaurence.ca](http://equipelaurence.ca)

Sainte-Adèle | Boisbriand | Joliette | Mont-Laurier | Gatineau | Sorel-Tracy

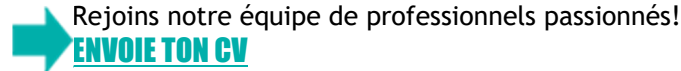

---

**De :** Calum MacDonald <[c.macdonald@mcintoshperry.com](mailto:c.macdonald@mcintoshperry.com)>

**Envoyé :** 12 septembre 2022 15:54

**À :** Francis Lacroix <[flacroix@equipelaurence.ca](mailto:flacroix@equipelaurence.ca)>

**Cc :** Benoit Bray <[bbray@equipelaurence.ca](mailto:bbray@equipelaurence.ca)>; Julien Levesque <[jlevesque@equipelaurence.ca](mailto:jlevesque@equipelaurence.ca)>

**Objet :** RE: Canadian Shield Roadway coordination

Hi Francis, yes I can provide the functional design plans. Do you know if the planned service connections are to the existing pipes on Maritime Way or to future Canadian Shield extension? Can you also pass along any plans you may have for your site. The City is reviewing some potential changes along Canadian Shield which will impact all 3 adjacent sites.

Thanks Francis,

Calum

**Calum MacDonald, P.Eng.**

**Technical Lead, Municipal Engineering**

T. 613.778.8609 | C. 613.809.5515

[c.macdonald@mcintoshperry.com](mailto:c.macdonald@mcintoshperry.com) | [www.mcintoshperry.com](http://www.mcintoshperry.com)

**McINTOSH PERRY**

*Turning Possibilities Into Reality*

---

**Confidentiality Notice** – If this email wasn't intended for you, please return or delete it. Click [here](#) to read all of the legal language around this concept.



Platinum  
member

---

**From:** Francis Lacroix <[flacroix@equipelaurence.ca](mailto:flacroix@equipelaurence.ca)>

**Sent:** September 12, 2022 3:49 PM

**To:** Calum MacDonald <[c.macdonald@mcintoshperry.com](mailto:c.macdonald@mcintoshperry.com)>

**Cc:** Benoit Bray <[bbray@equipelaurence.ca](mailto:bbray@equipelaurence.ca)>; Julien Levesque <[jlevesque@equipelaurence.ca](mailto:jlevesque@equipelaurence.ca)>

**Subject:** Canadian Shield Roadway coordination

You don't often get email from [flacroix@equipelaurence.ca](mailto:flacroix@equipelaurence.ca). [Learn why this is important](#)

Hi Calum,

We are working on the civil engineering plans for a project at the intersection of Kanata Avenue and Maritime Way.

For this reason, it is required that we coordinate our plans to yours to prevent any conflicts.

Would it be possible to send us the up-to-date plans for the proposed road?

Thank you,



**FRANCIS LACROIX** CPI

160, boulevard de l'Hôpital, unité 205, Gatineau (Qc) J8T 8J1

T 819 303-2700 p.703 | C 819 431-9582

[flacroix@equipelaurence.ca](mailto:flacroix@equipelaurence.ca) | [equipelaurence.ca](http://equipelaurence.ca)

[Sainte-Adèle](#) | [Boisbriand](#) | [Joliette](#) | [Mont-Laurier](#) | [Gatineau](#) | [Sorel-Tracy](#)

## Francis Lacroix

---

**Objet:** TR: 150 Kanata Avenue - Shared infrastructure coordination.

---

**De :** Curtis Melanson <[c.melanson@mcintoshperry.com](mailto:c.melanson@mcintoshperry.com)>

**Envoyé :** January 18, 2023 10:26 AM

**À :** Benoit Bray <[bbray@equipelaurence.ca](mailto:bbray@equipelaurence.ca)>; [joeytheberge@thebergehomes.com](mailto:joeytheberge@thebergehomes.com)

**Cc :** Chadi Kahwaji <[ckahwaji@emd-batimo.ca](mailto:ckahwaji@emd-batimo.ca)>; Paul Robinson <[probinson@probinsonconsulting.com](mailto:probinson@probinsonconsulting.com)>; Julien Levesque <[jlevesque@equipelaurence.ca](mailto:jlevesque@equipelaurence.ca)>; Francis Lacroix <[flacroix@equipelaurence.ca](mailto:flacroix@equipelaurence.ca)>; Rod Price <[rod@demarcoconstruction.ca](mailto:rod@demarcoconstruction.ca)>

**Objet :** RE: 150 Kanata Avenue - Shared infrastructure coordination.

Hi Benoit,

I've chatted with the team and have the following comments:

1 – Pipe slope from 1% to 0.3% - Yes, this can be accommodated. Based on the 375mm storm pipe it can be sloped at 0.25%. Please note that the City doesn't allow Tee connections at the invert of the pipe, they want connections at the springline of the pipe. But depending on your pipe size it may be 50% the nominal diameter of the 375mm and then you'd have to install a manhole which would allow you to get down close to the invert of the pipe.

2 – The 375mm pipe can accommodate the 80 L/s, this is not an issue.

3 – A lower connection is possible, we can potentially shift the manhole past the property line, however, it would require a drop structure for both inlet's and I don't know if that is in compliance with city guidelines. I need to look into it, but at the end of the day, it can be accommodated, I'm just not sure how it'll look.

4 – The sanitary pipe is a 250mm and can accommodate the 9.44 L/s without issue.

I'm available now until 11:30 for a call if you'd like to discuss, and then from 1:30-2:30 this afternoon.

Thanks,

**Curtis Melanson, C.E.T.**

**Practice Area Lead, Land Development**

T. 613.714.4621 | C. 613.857.0784

[c.melanson@mcintoshperry.com](mailto:c.melanson@mcintoshperry.com) | [www.mcintoshperry.com](http://www.mcintoshperry.com)

**McINTOSH PERRY**

*Turning Possibilities Into Reality*

---

Confidentiality Notice – If this email wasn't intended for you, please return or delete it. Click [here](#) to read all of the legal language around this concept.



Platinum  
member

---

**De :** Benoit Bray

**Envoyé :** December 23, 2022 1:50 PM

**À :** [c.melanson@mcintoshperry.com](mailto:c.melanson@mcintoshperry.com)

**Cc :** Chadi Kahwaji <[ckahwaji@emd-batimo.ca](mailto:ckahwaji@emd-batimo.ca)>; Paul Robinson <[probinson@probinsonconsulting.com](mailto:probinson@probinsonconsulting.com)>; Julien

Levesque <[jlevesque@equipelaurence.ca](mailto:jlevesque@equipelaurence.ca)>; Francis Lacroix <[flacroix@equipelaurence.ca](mailto:flacroix@equipelaurence.ca)>

**Objet :** 150 Kanata Avenue - Shared infrastructure coordination.

Good afternoon Curtis,

Like discussed in our site meeting, please see attached sketch showing how our project and building would connect to the shared access and let me know what you think. Also see important elements below.

- We are planning a retention basin underneath our underground parking slab. Would it be possible to lower the slope in the main stormwater pipe from 1 % to 0.3 % ?
- The maximum STM water flow would be around 80 L/s. Let me know how that affects the pipe diameter.
- For the sanitary connection, we would have to connect to Kanata Avenue in the manhole at the elevation of 94.980m to be able to connect our building. I have noticed that it is possible since the bottom of the manhole is around 92m. Let me know what you think.
- For the sanitary flow, we are at a peak of 9.44 L/s. Let me know how that affects the pipe diameter.

Let me know if we need to have a meeting. Our offices are closed until January 9<sup>th</sup>, but I am still available for a meeting or discussion. Just let me know when.

Si vous avez des questions, n'hésitez pas à communiquer avec moi.

Salutations,

*Veillez noter que nos bureaux seront fermés durant la période des Fêtes, soit du 26 décembre 2022 au 6 janvier 2023.*

**JOYEUSES FÊTES !**



**BENOIT BRAY** Ing., P. Eng.

160, boulevard de l'Hôpital, unité 205, Gatineau (Qc) J8T 8J1

T 819 303-2700 p.213 | C 514 258-3757

[bbray@equipelaurence.ca](mailto:bbray@equipelaurence.ca) | [equipelaurence.ca](http://equipelaurence.ca)

[Sainte-Adèle](#) | [Boisbriand](#) | [Joliette](#) | [Mont-Laurier](#) | [Gatineau](#)

# APPENDIX C

Stormwater Flows and Storage Requirements

Detailed Calculations

Storage tank drawing

Building flow control roof drainage declaration

# STORMWATER CALCULATIONS

## IDF CURVES FOR THE CITY OF OTTAWA

### **IDF curve equations (Intensity in mm/hr)**

100 year Intensity	= 1735.688 / (Time in min + 6.014) <sup>0.820</sup>
50 year Intensity	= 1569.580 / (Time in min + 6.014) <sup>0.820</sup>
25 year Intensity	= 1402.884 / (Time in min + 6.018) <sup>0.819</sup>
10 year Intensity	= 1174.184 / (Time in min + 6.014) <sup>0.816</sup>
5 year Intensity	= 998.071 / (Time in min + 6.053) <sup>0.814</sup>
2 year Intensity	= 732.951 / (Time in min + 6.199) <sup>0.810</sup>

## WATERSHED

The watersheds of the project are as displayed in the drawing below. The red zones represent the areas that are considered uncontrolled flow as the water will leave the site without control. The other watersheds are named based on the catch basin numbers associated. Therefore, CB-01, CB-02 and CB-03 as well as a part of the building are four watersheds that will only be built during the second phase of the project. Those areas will be considered as grass draining toward the phase 1 for the initial calculations.

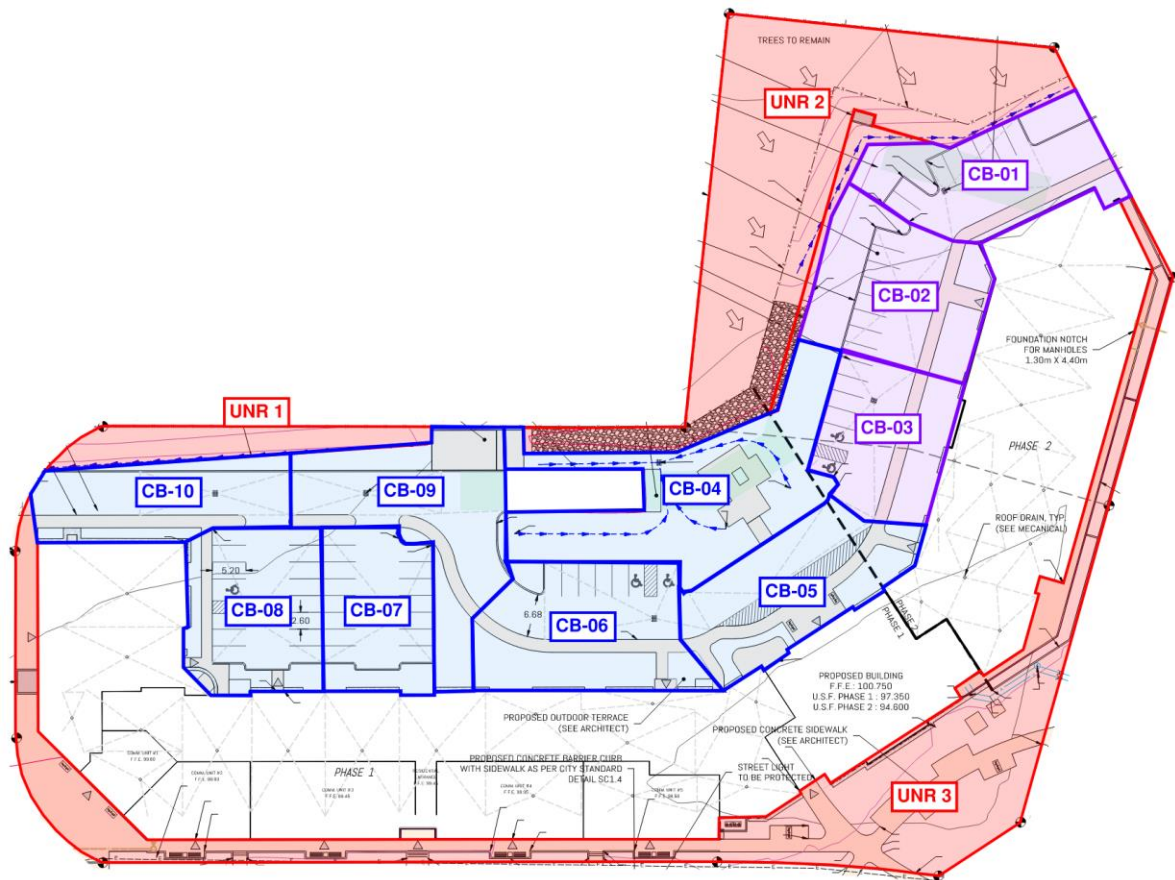

## HYPOTHESES

- The uncontrolled flow is the same for the phase 1 and 2
- The area of the phase 2 is left as grass draining toward the phase 1 for the phase 1 calculations
- The roof are a part of the drainage areas draining toward the underground tanks

Here are the calculations for the pre-development flowrate as asked by the city. The IDF curves provided on the previous page and a runoff coefficient of 0.57 were used.

**TABLE 1 - 5-YEAR PRE-DEVELOPMENT**

Time of concentration (min)	Intensity (mm/hr)	Flowrate (L/s)
5.0	141.2	333.2
10.0	104.2	245.9
15.0	83.6	197.2
<b>20.0</b>	<b>70.3</b>	<b>165.8</b>

\*The IDF curves were taken from the city of Ottawa sewer design guidelines and C=0.57.

\*The total area of the project is 14 896 m<sup>2</sup>

**TABLE 2 - PROPOSED POST-DEVELOPMENT CATCHMENT AREAS - PHASE 1**

Drainage area	Total area (m <sup>2</sup> )	Impervious surfaces		Grass surfaces		5-year runoff coefficient	100-year runoff coefficient
		Area (m <sup>2</sup> )	Runoff coefficient	Area (m <sup>2</sup> )	Runoff coefficient		
<i>Zone 1</i>							
Phase 2	3295	733	0.900	2562	0.250	0.395	0.465
CB-04	734	620	0.900	114	0.250	0.799	0.893
CB-05	567	567	0.900	0	0.250	0.900	1.000
CB-06	635	635	0.900	0	0.250	0.900	1.000
CB-07	430	430	0.900	0	0.250	0.900	1.000
CB-08	533	533	0.900	0	0.250	0.900	1.000
CB-09	674	598	0.900	76	0.250	0.827	0.922
CB-10	462	407	0.900	55	0.250	0.823	0.918
Building	3731	3731	0.900	0	0.250	0.900	1.000
<b>Total Regulated</b>	<b>11061</b>	<b>8254</b>	<b>-</b>	<b>2807</b>	<b>-</b>	<b>0.735</b>	<b>0.826</b>
UNR-01	261	0	0.900	261	0.250	-	0.313
UNR-02	1766	99	0.900	1667	0.250	-	0.351
UNR-03	1808	888	0.900	920	0.250	-	0.650
<b>Total Unregulated</b>	<b>3835</b>	<b>987</b>	<b>-</b>	<b>2848</b>	<b>-</b>	<b>-</b>	<b>0.489</b>

\* The 100-year runoff coefficients are determined by increasing the 5-year runoff coefficients by 25% as per the city of Ottawa sewer design guidelines.

\* The roof drainage is included in the calculation of the zone 1 drainage area



## RUNOFF COEFFICIENT CALCULATION

$$C = \frac{\sum(A_i \times C_i)}{\sum A}$$

Where  $A_i$  is the Area of a certain material type

$C_i$  is the runoff coefficient of a certain material type

Example:

$$C_{CB-04} = \frac{698 \times 0.900 + 186 \times 0.250}{698 + 186} = 0.763$$

### TABLE 3 - PROPOSED UNCONTROLLED FLOW

Parameters	Values	Units
Impervious surfaces	987	m <sup>2</sup>
Grass surfaces	2848	m <sup>2</sup>
Total area	3835	m <sup>2</sup>
100-year Runoff coefficient	0.489	-
Time of concentration	10	min
Uncontrolled 100-year flow	93.2	ℓ/s

\* The 100-year runoff coefficients are determined by increasing the 5-year runoff coefficients by 25% as per the city of Ottawa sewer design guidelines.

### TABLE 4 - PROPOSED CONTROLLED FLOW FOR PHASE 1

Parameters	Values	Units
5-year pre-development flow	165.8	ℓ/s
100-year uncontrolled flow	93.2	ℓ/s
Allowable release rate / Controlled flow	72.6	ℓ/s
Average release rate for calculations	33.3	ℓ/s
Release rate controlled by ICD - Phase 1	66.6	ℓ/s
Release rate controlled by ICD - Phase 2	6.0	ℓ/s
5-year storage requirements - Phase 1	<b>226.8</b>	m <sup>3</sup>
100-year storage requirements - Phase 1	<b>544.6</b>	m <sup>3</sup>

\*Storage requirement calculations includes a 20% increase in rainfall

\*Storage requirement calculations includes a 10% increase in volume

TABLE 5 - STORAGE REQUIREMENTS - CITY OF OTTAWA IDF CURVES, AVERAGE FLOW OF 33.3 L/s - PHASE 1

Tc (min)	I <sub>2</sub> (mm/h)	I <sub>5</sub> (mm/h)	I <sub>100</sub> (mm/h)	Q <sub>in-2yr</sub> (L/s)	Q <sub>in-5yr</sub> (L/s)	Q <sub>in-100yr</sub> (L/s)	Q <sub>out</sub> (L/s)	Q <sub>in-out-2yr</sub> (L/s)	Q <sub>in-out-5yr</sub> (L/s)	Q <sub>in-out-100yr</sub> (L/s)	V <sub>5</sub> (m³)	V <sub>100</sub> (m³)
5.0	103.6	141.2	242.7	233.9	318.8	615.6	33.3	200.6	285.5	582.3	85.7	174.7
10.0	76.8	104.2	178.6	173.5	235.3	452.9	33.3	140.2	202.0	419.6	121.2	251.8
15.0	61.8	83.6	142.9	139.5	188.7	362.4	33.3	106.2	155.4	329.1	139.9	296.2
20.0	52.0	70.3	120.0	117.5	158.7	304.2	33.3	84.2	125.4	270.9	150.4	325.1
25.0	45.2	60.9	103.8	102.0	137.5	263.4	33.3	68.7	104.2	230.1	156.3	345.2
30.0	40.0	53.9	91.9	90.4	121.8	233.0	33.3	57.1	88.5	199.7	159.3	359.5
35.0	36.1	48.5	82.6	81.4	109.6	209.5	33.3	48.1	76.3	176.2	160.2	369.9
40.0	32.9	44.2	75.1	74.2	99.8	190.6	33.3	40.9	66.5	157.3	159.6	377.5
45.0	30.2	40.6	69.1	68.3	91.8	175.1	33.3	35.0	58.5	141.8	157.8	383.0
50.0	28.0	37.7	64.0	63.3	85.0	162.2	33.3	30.0	51.7	128.9	155.2	386.7
55.0	26.2	35.1	59.6	59.1	79.3	151.2	33.3	25.8	46.0	117.9	151.9	389.2
60.0	24.6	32.9	55.9	55.5	74.4	141.8	33.3	22.2	41.1	108.5	148.0	390.5
65.0	23.2	31.0	52.6	52.3	70.1	133.5	33.3	19.0	36.8	100.2	143.6	390.9
70.0	21.9	29.4	49.8	49.5	66.3	126.3	33.3	16.2	33.0	93.0	138.7	390.6
75.0	20.8	27.9	47.3	47.0	63.0	119.9	33.3	13.7	29.7	86.6	133.6	389.5
80.0	19.8	26.6	45.0	44.8	60.0	114.1	33.3	11.5	26.7	80.8	128.1	387.9
85.0	18.9	25.4	43.0	42.8	57.3	109.0	33.3	9.5	24.0	75.7	122.4	385.8
90.0	18.1	24.3	41.1	41.0	54.9	104.3	33.3	7.7	21.6	71.0	116.4	383.3
95.0	17.4	23.3	39.4	39.3	52.6	100.0	33.3	6.0	19.3	66.7	110.2	380.3
100.0	16.7	22.4	37.9	37.8	50.6	96.1	33.3	4.5	17.3	62.8	103.8	377.0

\* The area and coefficients used for these calculations are described as the total regulated area (table 2)

**TABLE 6 - PROPOSED STORMWATER STORAGE**

Parameters	Values	Units
5-year required storage <sup>1</sup>	227	m <sup>3</sup>
100-year required storage <sup>1,2</sup>	545	m <sup>3</sup>
Maximum accumulation on roof <sup>3</sup>	150	mm
Volume retained on roof <sup>3</sup>	121	m <sup>3</sup>
Volume retained in underground concrete tank	415	m <sup>3</sup>
Volume retained in sewer structures and pipes	10	m <sup>3</sup>
<b>Total storage volume available</b>	<b>546</b>	<b>m<sup>3</sup></b>

1 - A 10% increase was included in the volume requirement as an extra safety measure

2 - A 20% increase to rainfall was included for the climate change effects

3 - To be verified with the mechanical engineer

**TABLE - 7 INLET CONTROL DEVICE (ICD)**

Zone	Pipe	Flowrate (L/s)	Water level	Invert (m)	Water head (m)	Type*
1	375mm PVC	66.6	97.350	95.935	1.41	Orifice

\*The type of ICD and specifications has to be validated with the manufacturer

**TABLE - 8 ORIFICE DESIGN (ICD)**

Variable	Values	Units
<u>Orifice Equation</u>		
$Q = CA\sqrt{2gh}$		
Q	Flowrate	66.6 L/s
C	Coefficient	0.72
g	Gravity constant	9.81 m <sup>2</sup> /s
h	Water head	1.41 m <sup>3</sup>
A	Area of opening	0.018 m <sup>2</sup>
D	Opening Diameter	<b>149.5</b> mm

**TABLE 9 - PROPOSED POST-DEVELOPMENT CATCHMENT AREAS - PHASE 2**

Drainage area	Total area (m <sup>2</sup> )	Impervious surfaces		Grass surfaces		5-year runoff coefficient	100-year runoff coefficient
		Area (m <sup>2</sup> )	Runoff coefficient	Area (m <sup>2</sup> )	Runoff coefficient		
<i>Zone 1</i>							
CB-04	734	620	0.900	114	0.250	0.799	0.893
CB-05	567	567	0.900	0	0.250	0.900	1.000
CB-06	635	635	0.900	0	0.250	0.900	1.000
CB-07	430	430	0.900	0	0.250	0.900	1.000
CB-08	533	533	0.900	0	0.250	0.900	1.000
CB-09	674	598	0.900	76	0.250	0.827	0.922
CB-10	462	407	0.900	55	0.250	0.823	0.918
Building P1	3731	3731	0.900	0	0.250	0.900	1.000
<b>Total Regulated</b>	<b>7766</b>	<b>7521</b>	<b>-</b>	<b>245</b>	<b>-</b>	<b>0.879</b>	<b>0.978</b>
<i>Zone 2</i>							
CB-01	555	555	0.900	0	0.250	0.900	0.950
CB-02	592	592	0.900	0	0.250	0.900	1.000
CB-03	565	565	0.900	0	0.250	0.900	1.000
Building P2	1583	1583	0.900	0	0.250	0.900	1.000
<b>Total Regulated</b>	<b>3295</b>	<b>3295</b>	<b>-</b>	<b>0</b>	<b>-</b>	<b>0.900</b>	<b>1.000</b>
UNR-01	261	0	0.900	261	0.250	-	<b>0.313</b>
UNR-02	1766	99	0.900	1667	0.250	-	<b>0.351</b>
UNR-03	1808	888	0.900	920	0.250	-	<b>0.650</b>
<b>Total Unregulated</b>	<b>3835</b>	<b>987</b>	<b>-</b>	<b>2848</b>	<b>-</b>	<b>-</b>	<b>0.489</b>

\* The 100-year runoff coefficients are determined by increasing the 5-year runoff coefficients by 25% as per the city of Ottawa sewer design guidelines.

\* The roof drainage is included in the calculation of the drainage areas

**TABLE 10 - PROPOSED CONTROLLED FLOW - PHASE 2**

Parameters	Values	Units
5-year pre-development flow	165.8	ℓ/s
100-year uncontrolled flow	93.2	ℓ/s
Allowable release rate / Controlled flow	72.6	ℓ/s
Release rate controlled by ICD - Phase 1	66.6	ℓ/s
Average release rate for calculations	33.3	ℓ/s
5-year storage requirements - Phase 1	<b>136.6</b>	m <sup>3</sup>
100-year storage requirements - Phase 1	<b>427.2</b>	m <sup>3</sup>
Release rate controlled by ICD - Phase 2	6.0	ℓ/s
Average release rate for calculations	3.0	ℓ/s
5-year storage requirements - Phase 2	<b>103.5</b>	m <sup>3</sup>
100-year storage requirements - Phase 2	<b>285.0</b>	m <sup>3</sup>

\*Storage requirement calculations includes a 20% increase in rainfall

\*Storage requirement calculations includes a 10% increase in volume

**TABLE 11 - PROPOSED STORMWATER STORAGE - PHASE 2**

Description	Parameters	Values	Units
Zone 1	5-year required storage <sup>1</sup>	<b>137</b>	m <sup>3</sup>
	100-year required storage <sup>1,2</sup>	<b>427</b>	m <sup>3</sup>
	Maximum accumulation on roof	150	mm
	Volume retained on roof	121	m <sup>3</sup>
	Volume retained in underground concrete tank	415	m <sup>3</sup>
	Volume retained in sewer structures and pipes	10	m <sup>3</sup>
	<b>Total storage volume available</b>	<b>546</b>	<b>m<sup>3</sup></b>
Zone 2	5-year required storage <sup>1</sup>	<b>104</b>	m <sup>3</sup>
	100-year required storage <sup>1,2</sup>	<b>285</b>	m <sup>3</sup>
	Maximum accumulation on roof	150	mm
	Volume retained on roof	65	m <sup>3</sup>
	Volume retained in underground concrete tank	215	m <sup>3</sup>
	Volume retained in sewer structures and pipes	5	m <sup>3</sup>
<b>Total storage volume available</b>	<b>285</b>	<b>m<sup>3</sup></b>	

1 - A 10% increase was included in the volume requirement as an extra safety measure

2 - A 20% increase to rainfall was included for the climate change effects

3 - To be verified with the mechanical engineer

TABLE 12 - STORAGE REQUIREMENTS - CITY OF OTTAWA IDF CURVES, AVERAGE FLOW OF 33.3 L/s - PHASE 1

Tc (min)	I <sub>2</sub> (mm/h)	I <sub>5</sub> (mm/h)	I <sub>100</sub> (mm/h)	Q <sub>in-2yr</sub> (L/s)	Q <sub>in-5yr</sub> (L/s)	Q <sub>in-100yr</sub> (L/s)	Q <sub>out</sub> (L/s)	Q <sub>in-out-2yr</sub> (L/s)	Q <sub>in-out-5yr</sub> (L/s)	Q <sub>in-out-100yr</sub> (L/s)	V <sub>5</sub> (m <sup>3</sup> )	V <sub>100</sub> (m <sup>3</sup> )
5.0	103.6	141.2	242.7	196.5	267.9	512.2	33.3	163.2	234.6	478.9	70.4	143.7
10.0	76.8	104.2	178.6	145.7	197.7	376.8	33.3	112.4	164.4	343.5	98.6	206.1
15.0	61.8	83.6	142.9	117.2	158.5	301.6	33.3	83.9	125.2	268.3	112.7	241.4
20.0	52.0	70.3	120.0	98.7	133.3	253.1	33.3	65.4	100.0	219.8	120.0	263.8
25.0	45.2	60.9	103.8	85.7	115.5	219.2	33.3	52.4	82.2	185.9	123.4	278.8
30.0	40.0	53.9	91.9	76.0	102.3	193.9	33.3	42.7	69.0	160.6	124.2	289.0
35.0	36.1	48.5	82.6	68.4	92.1	174.3	33.3	35.1	58.8	141.0	123.4	296.1
40.0	32.9	44.2	75.1	62.4	83.8	158.6	33.3	29.1	50.5	125.3	121.3	300.7
45.0	30.2	40.6	69.1	57.4	77.1	145.7	33.3	24.1	43.8	112.4	118.2	303.6
50.0	28.0	37.7	64.0	53.2	71.4	135.0	33.3	19.9	38.1	101.7	114.4	305.0
55.0	26.2	35.1	59.6	49.7	66.6	125.8	33.3	16.4	33.3	92.5	110.0	305.4
60.0	24.6	32.9	55.9	46.6	62.5	118.0	33.3	13.3	29.2	84.7	105.1	304.8
65.0	23.2	31.0	52.6	43.9	58.9	111.1	33.3	10.6	25.6	77.8	99.8	303.4
70.0	21.9	29.4	49.8	41.6	55.7	105.1	33.3	8.3	22.4	71.8	94.2	301.5
75.0	20.8	27.9	47.3	39.5	52.9	99.7	33.3	6.2	19.6	66.4	88.3	298.9
80.0	19.8	26.6	45.0	37.6	50.4	95.0	33.3	4.3	17.1	61.7	82.1	295.9
85.0	18.9	25.4	43.0	35.9	48.1	90.7	33.3	2.6	14.8	57.4	75.6	292.5
90.0	18.1	24.3	41.1	34.4	46.1	86.8	33.3	1.1	12.8	53.5	69.0	288.7
95.0	17.4	23.3	39.4	33.0	44.2	83.2	33.3	-0.3	10.9	49.9	62.2	284.6
100.0	16.7	22.4	37.9	31.8	42.5	80.0	33.3	-1.5	9.2	46.7	55.3	280.2

TABLE 13 - STORAGE REQUIREMENTS - CITY OF OTTAWA IDF CURVES, AVERAGE FLOW OF 3.0 L/s - PHASE 2

Tc (min)	I <sub>2</sub> (mm/h)	I <sub>5</sub> (mm/h)	I <sub>100</sub> (mm/h)	Q <sub>in-2yr</sub> (L/s)	Q <sub>in-5yr</sub> (L/s)	Q <sub>in-100yr</sub> (L/s)	Q <sub>out</sub> (L/s)	Q <sub>in-out-2yr</sub> (L/s)	Q <sub>in-out-5yr</sub> (L/s)	Q <sub>in-out-100yr</sub> (L/s)	V <sub>5</sub> (m³)	V <sub>100</sub> (m³)
110.0	15.6	20.8	35.2	12.8	17.2	32.2	3.0	9.8	14.1	29.2	93.2	192.7
120.0	14.6	19.5	32.9	12.0	16.0	30.1	3.0	9.0	13.0	27.1	93.7	195.0
130.0	13.7	18.3	30.9	11.3	15.1	28.3	3.0	8.3	12.0	25.3	94.0	197.0
140.0	12.9	17.3	29.2	10.6	14.2	26.7	3.0	7.6	11.2	23.7	94.1	198.7
145.0	12.6	16.8	28.4	10.4	13.8	26.0	3.0	7.3	10.8	22.9	94.1	199.5
150.0	12.3	16.4	27.6	10.1	13.5	25.3	3.0	7.1	10.5	22.2	94.1	200.2
160.0	11.7	15.6	26.2	9.6	12.8	24.0	3.0	6.6	9.8	21.0	94.0	201.5
170.0	11.1	14.8	25.0	9.2	12.2	22.9	3.0	6.1	9.2	19.9	93.8	202.6
180.0	10.6	14.2	23.9	8.8	11.7	21.9	3.0	5.7	8.7	18.9	93.5	203.6
190.0	10.2	13.6	22.9	8.4	11.2	21.0	3.0	5.4	8.2	17.9	93.1	204.4
200.0	9.8	13.0	22.0	8.1	10.7	20.1	3.0	5.0	7.7	17.1	92.7	205.1
210.0	9.4	12.6	21.1	7.8	10.3	19.4	3.0	4.7	7.3	16.3	92.2	205.7
220.0	9.1	12.1	20.4	7.5	10.0	18.6	3.0	4.5	6.9	15.6	91.7	206.2
230.0	8.8	11.7	19.7	7.2	9.6	18.0	3.0	4.2	6.6	15.0	91.1	206.6
240.0	8.5	11.3	19.0	7.0	9.3	17.4	3.0	4.0	6.3	14.4	90.4	206.9
250.0	8.2	10.9	18.4	6.8	9.0	16.8	3.0	3.7	6.0	13.8	89.7	207.2
260.0	8.0	10.6	17.8	6.6	8.7	16.3	3.0	3.5	5.7	13.3	89.0	207.3
270.0	7.7	10.3	17.3	6.4	8.5	15.8	3.0	3.3	5.4	12.8	88.3	207.4
280.0	7.5	10.0	16.8	6.2	8.2	15.4	3.0	3.2	5.2	12.3	87.5	207.5
290.0	7.3	9.7	16.3	6.0	8.0	14.9	3.0	3.0	5.0	11.9	86.6	207.4

**TABLE - 14 INLET CONTROL DEVICE (ICD)**

ZONE	PIPE	FLOWRATE (L/s)	WATER LEVEL	INVERT (m)	WATER HEAD (m)	TYPE*
2	300mm PVC	9.9	94.600	93.600	1.00	Type vortex by John Meunier model 100 VHV-1 or approved equivalent

\*The type of ICD and specifications has to be validated with the manufacturer

**FIGURE 1 HYDROVEX VHV-1 OUTFLOW CURVE**

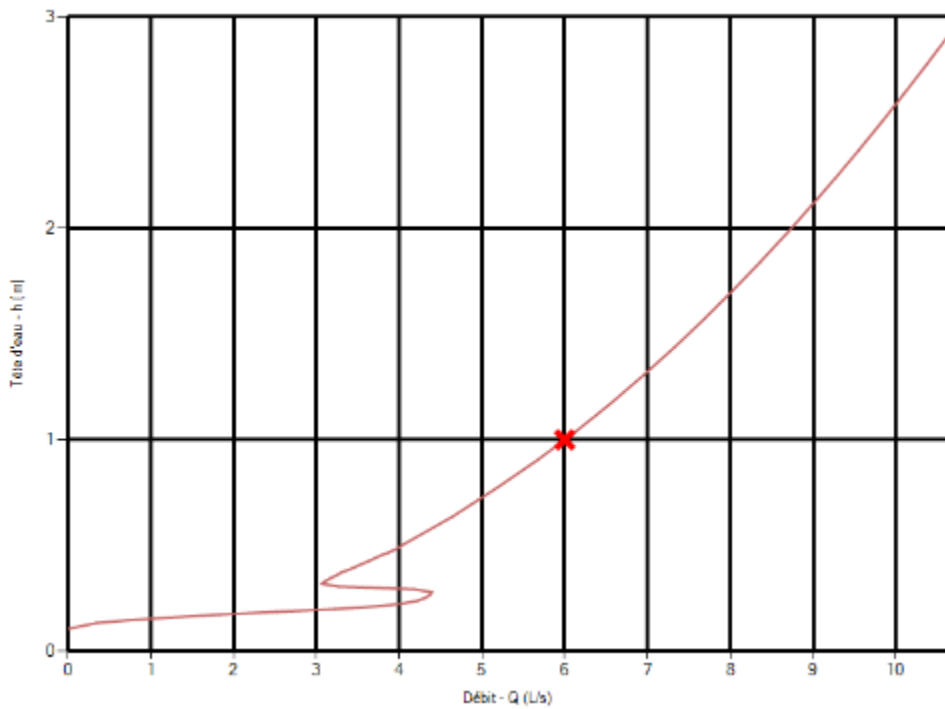



**TABLE 15 - ROOF FLOW AND VOLUME**

Parameters	Values	Units
<i>Phase 1</i>		
Controlled flow per drain, 6.35mm opening	0.95	L/s
Number of drains	17.0	L/s
Total controlled flow	16.1	L/s
Maximum volume accumulated - 5-yr	53.9	m <sup>3</sup>
Maximum volume accumulated - 100-yr	114.4	m <sup>3</sup>
Maximum available volume at 150mm	121.0	m <sup>3</sup>
<i>Phase 2</i>		
Controlled flow per drain, 6.35mm opening	0.95	L/s
Number of drains	11.0	L/s
Total controlled flow	10.4	L/s
Maximum volume accumulated - 5-yr	26.4	m <sup>3</sup>
Maximum volume accumulated - 100-yr	57.2	m <sup>3</sup>
Maximum available volume at 150mm	65.0	m <sup>3</sup>

**TABLE 16 - ROOF CALCULATIONS - PHASE 1**

Accumulation (m)	Accumulation surface (m <sup>2</sup> )*	Volume (m <sup>3</sup> )
0.150	2420.36	121.02
0.135	2097.76	94.40
0.130	1947.65	84.40
0.110	1395.70	51.18
0.100	1153.39	38.45

\*The accumulation surface represent the total retention area on the roof for the 17 drains

**TABLE 17 - ROOF CALCULATIONS - PHASE 2**

Accumulation (m)	Accumulation surface (m <sup>2</sup> )*	Volume (m <sup>3</sup> )
0.150	1300.12	65.01
0.145	1263.35	61.06
0.140	1209.86	56.46
0.110	749.46	27.48
0.100	619.41	20.65

\*The accumulation surface represent the total retention area on the roof for the 11 drains

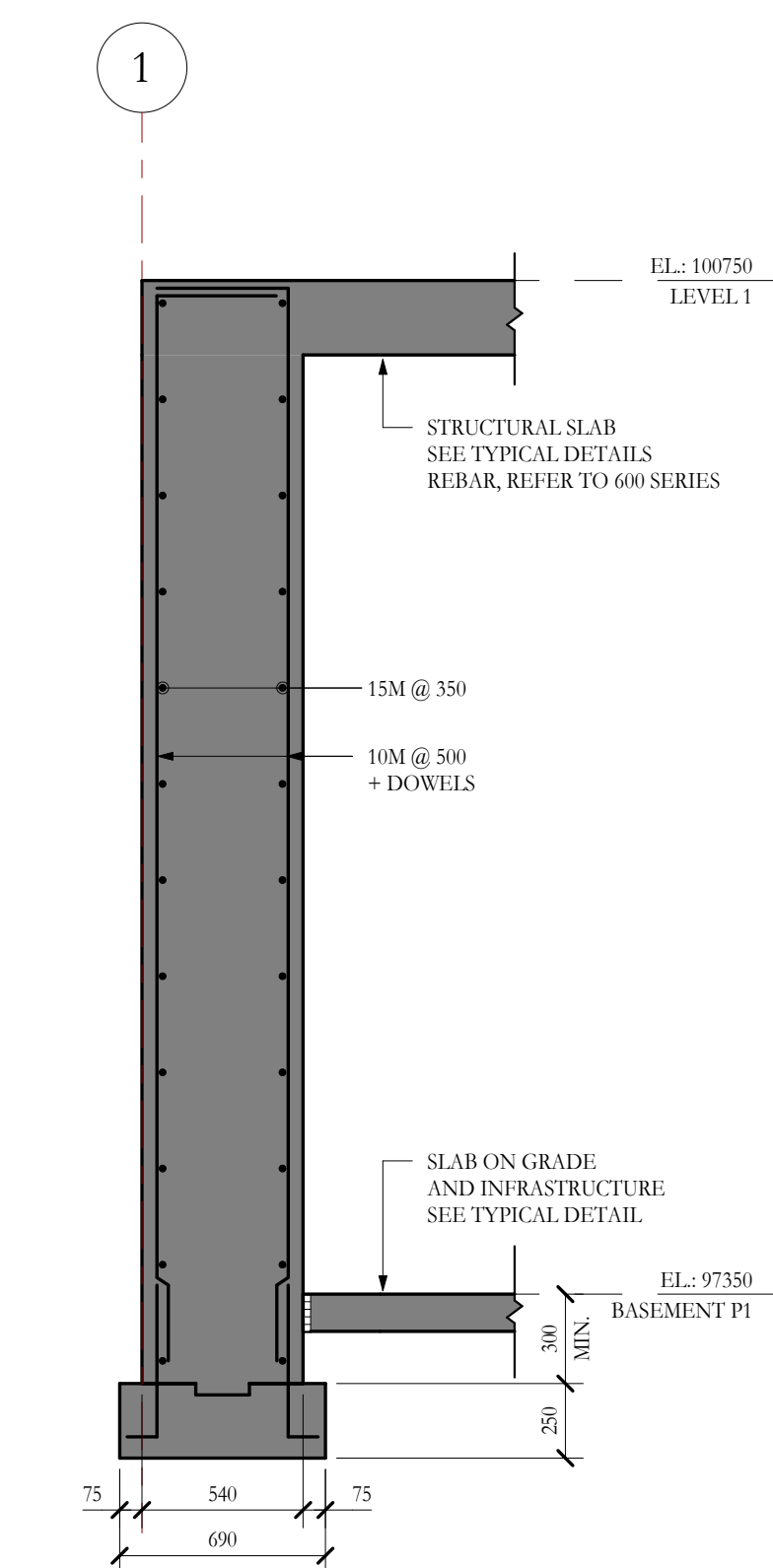

1 COUPE  
S-100A ECH: 1:25

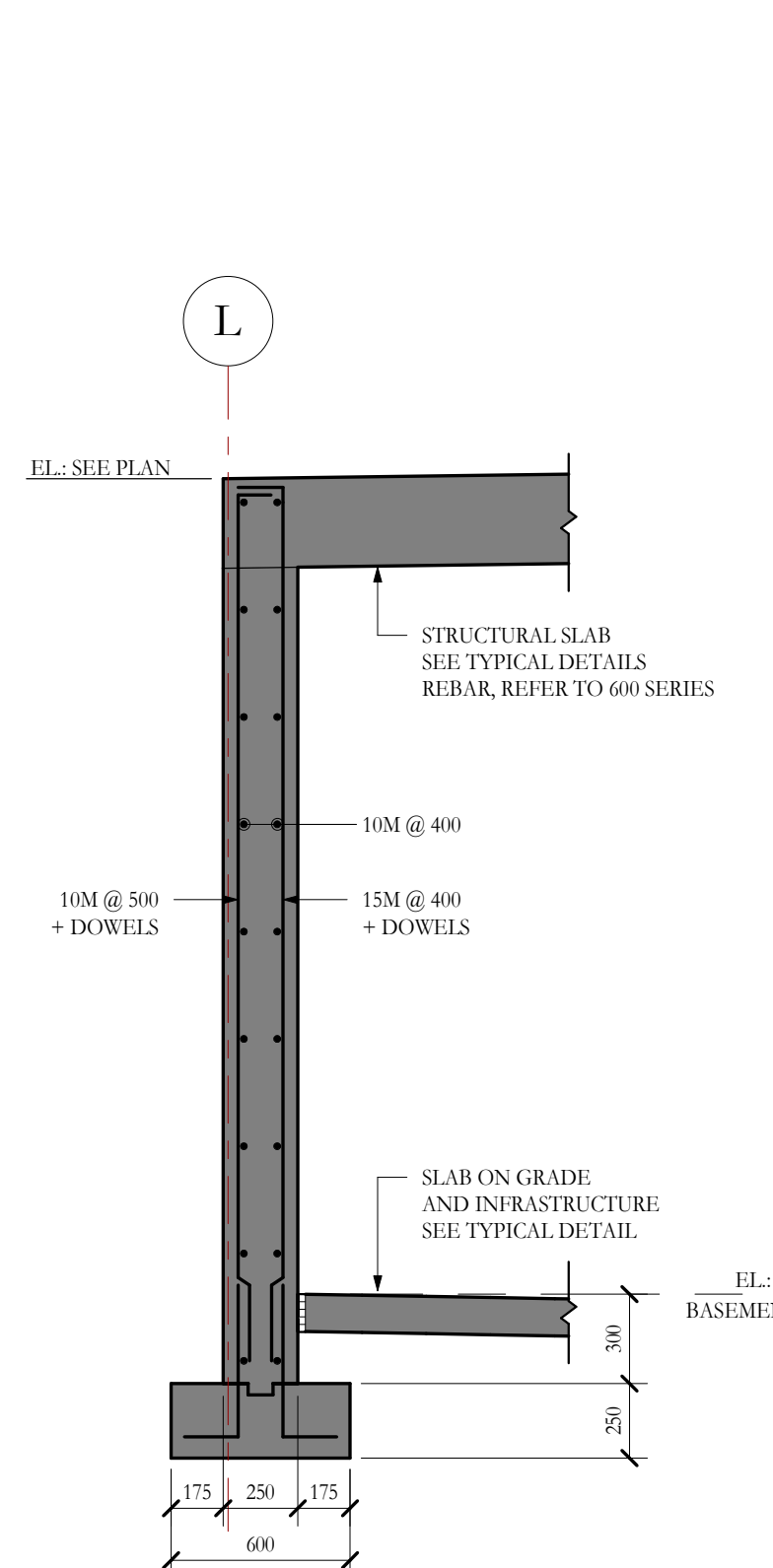

2 COUPE  
S-100A ECH: 1:25

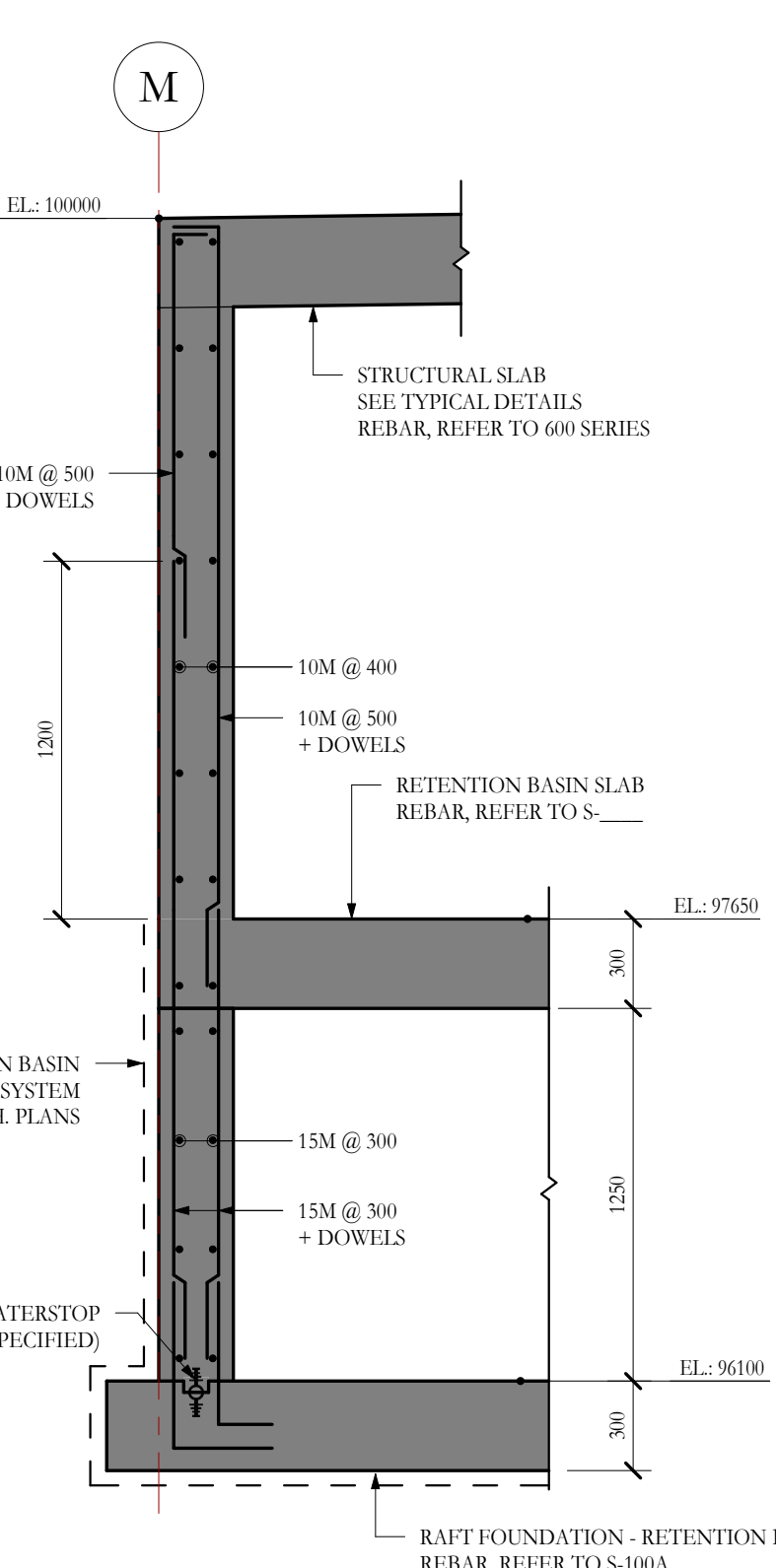

3 COUPE  
S-100A ECH: 1:25

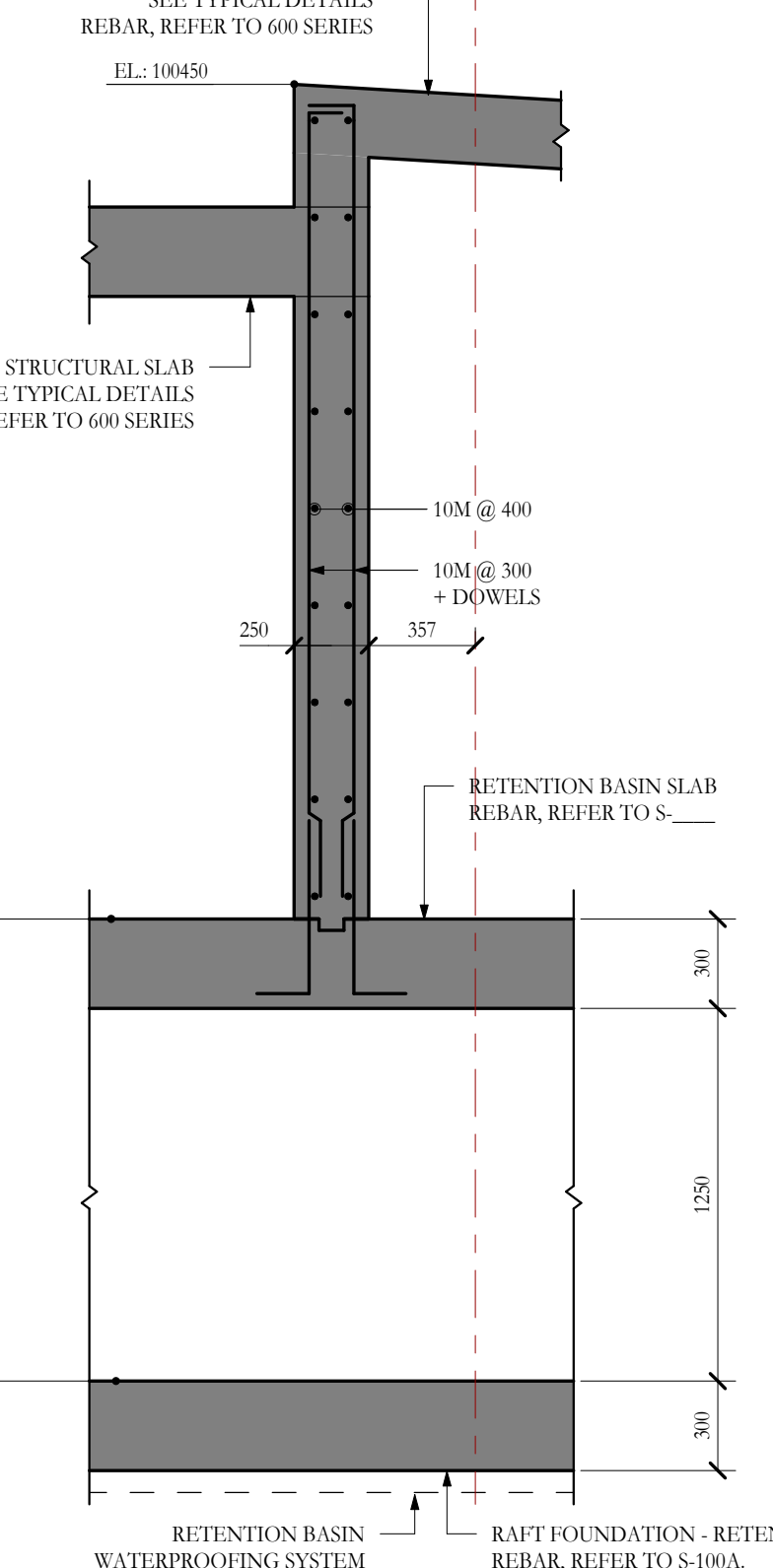

4 COUPE  
S-101A ECH: 1:25

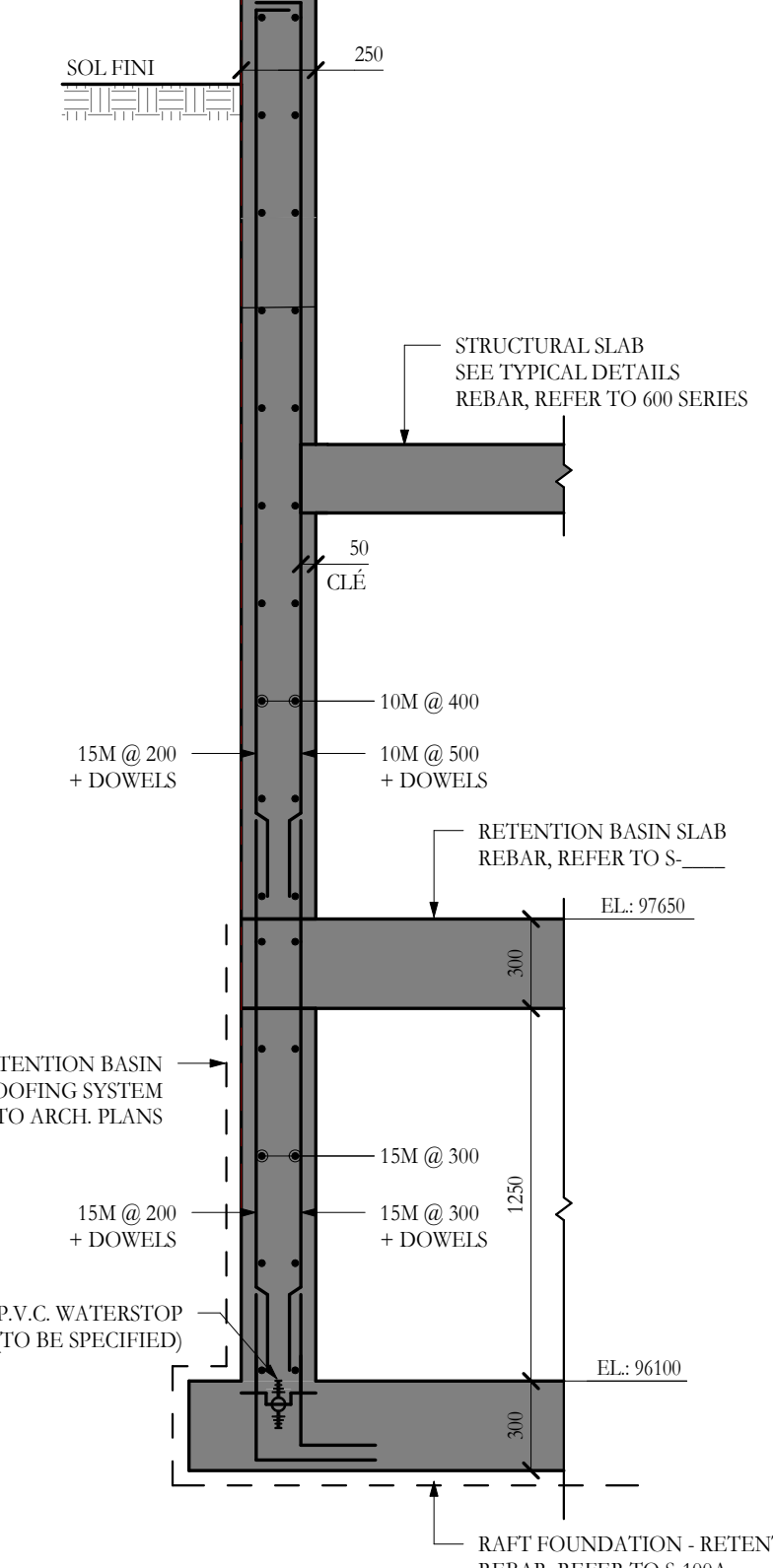

5 COUPE  
S-100A ECH: 1:25

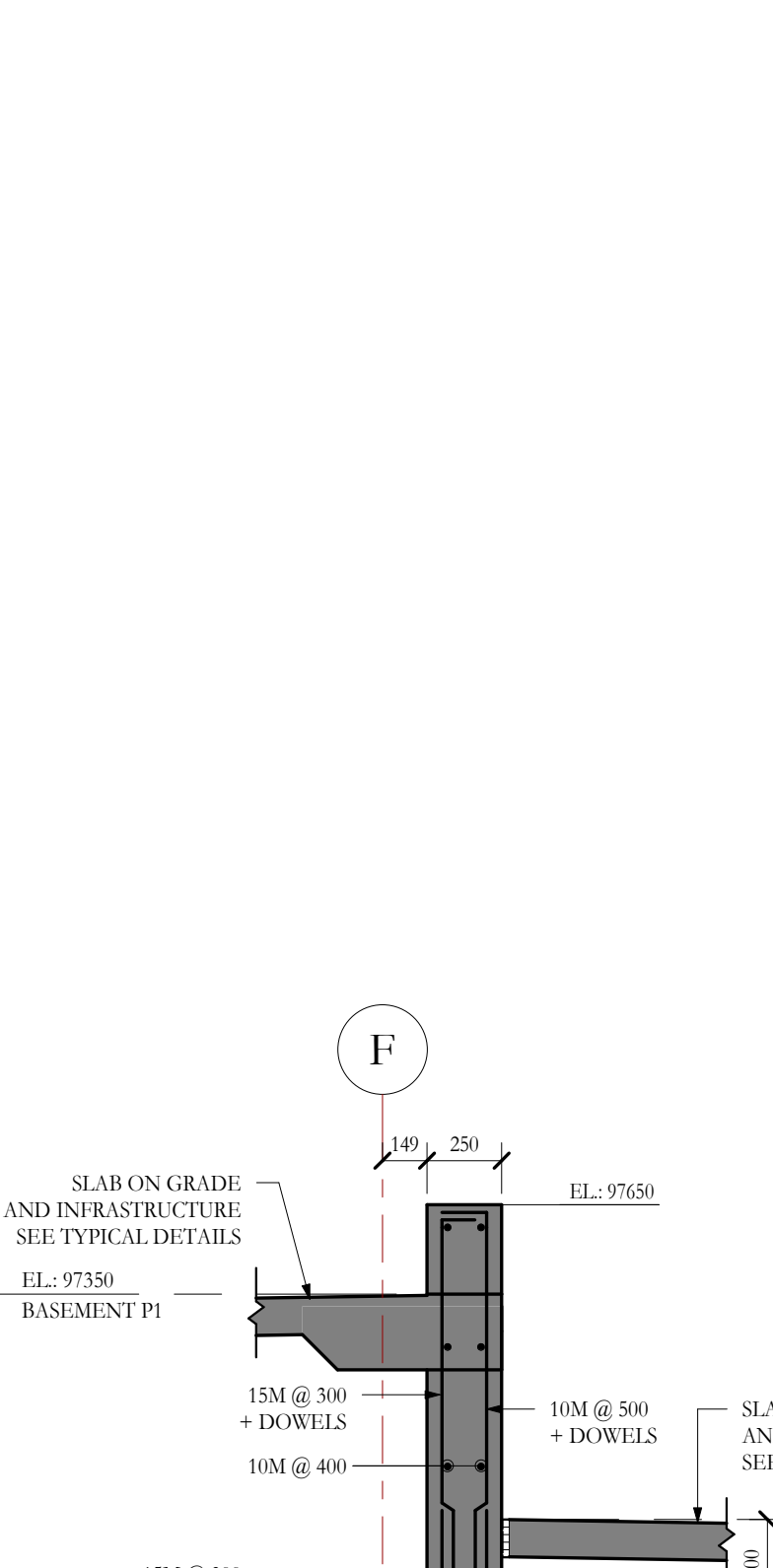

6 COUPE  
S-100A ECH: 1:25

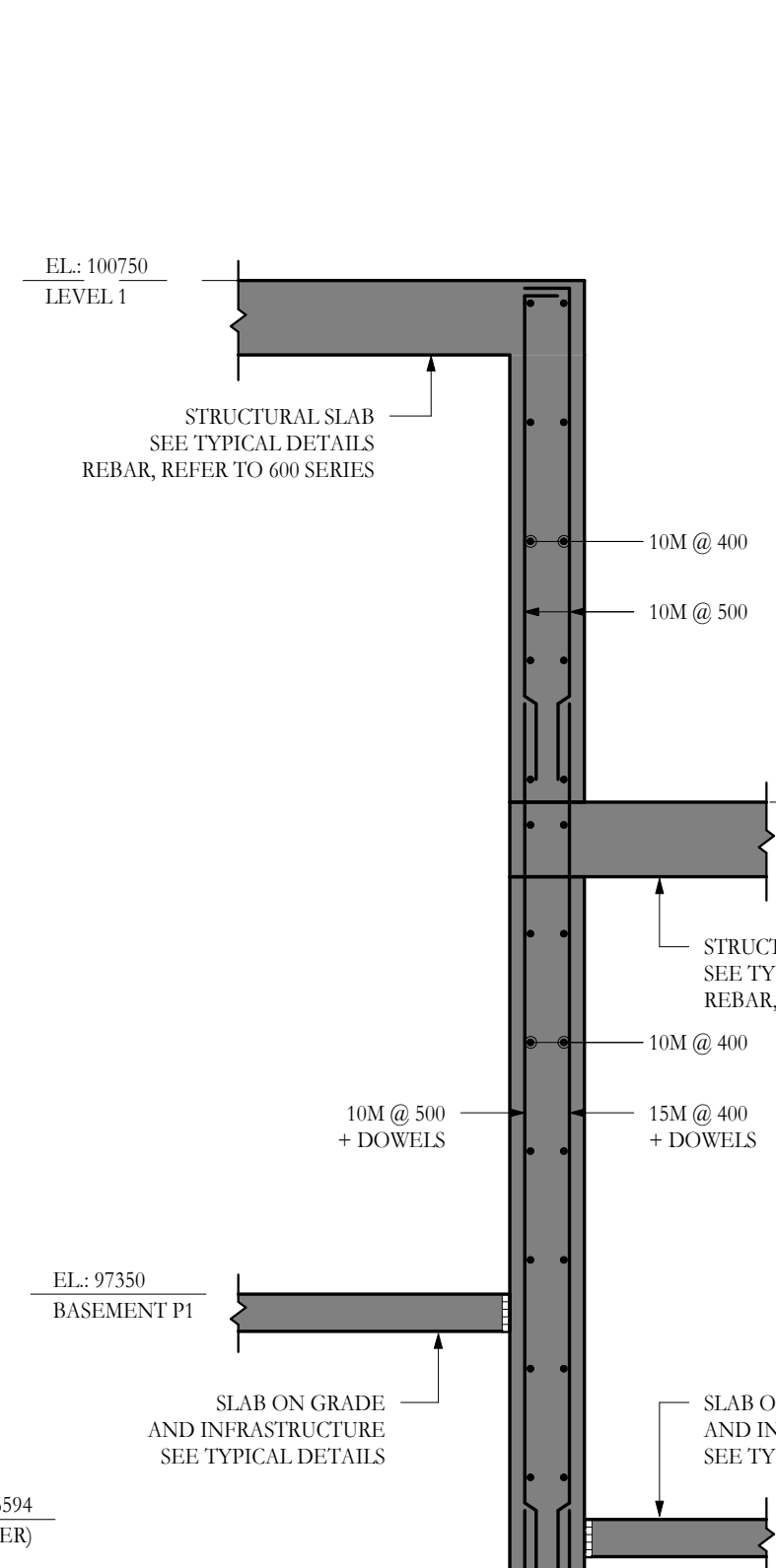

7 COUPE  
S-100A ECH: 1:25

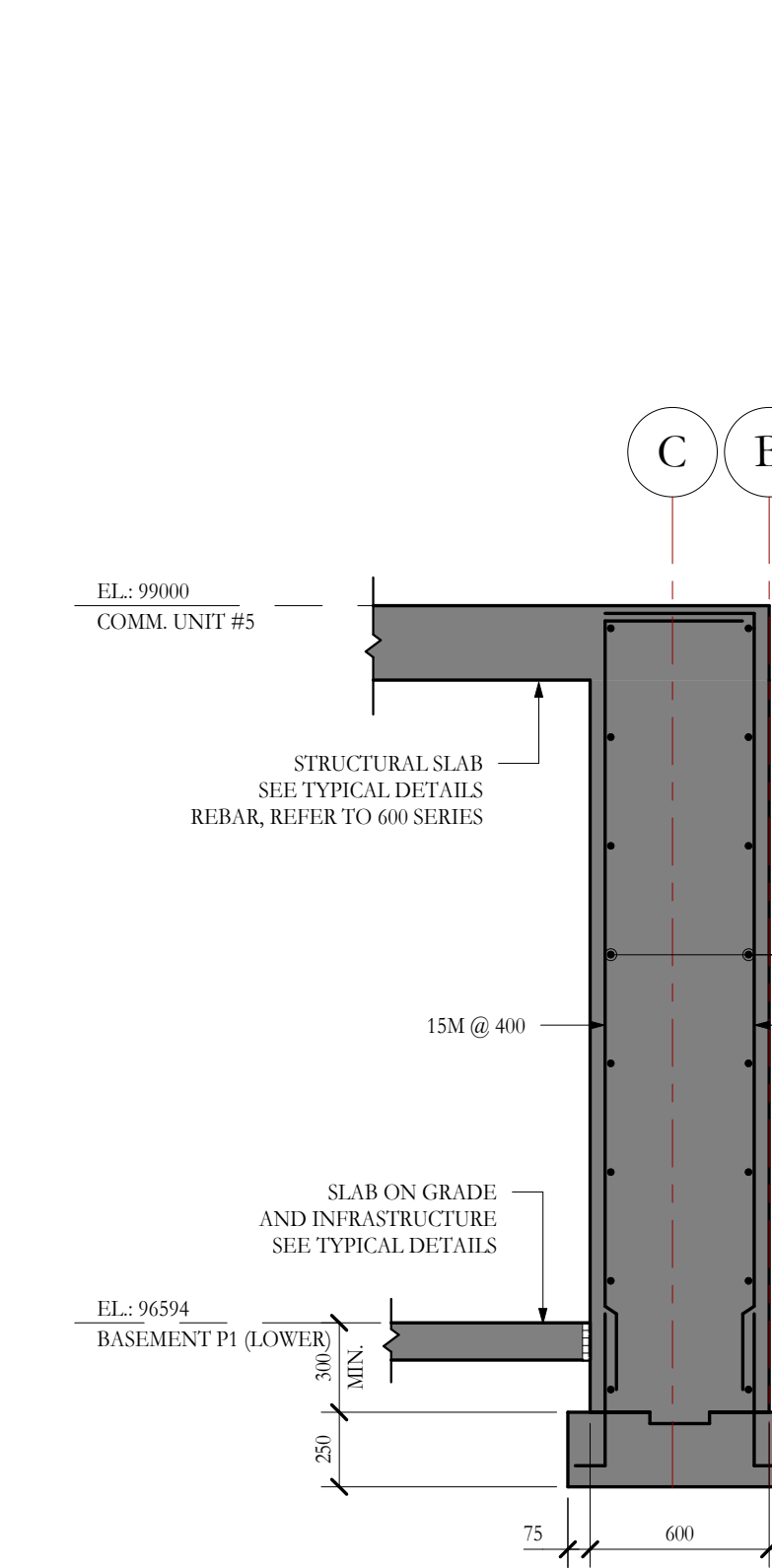

8 COUPE  
S-100A ECH: 1:25

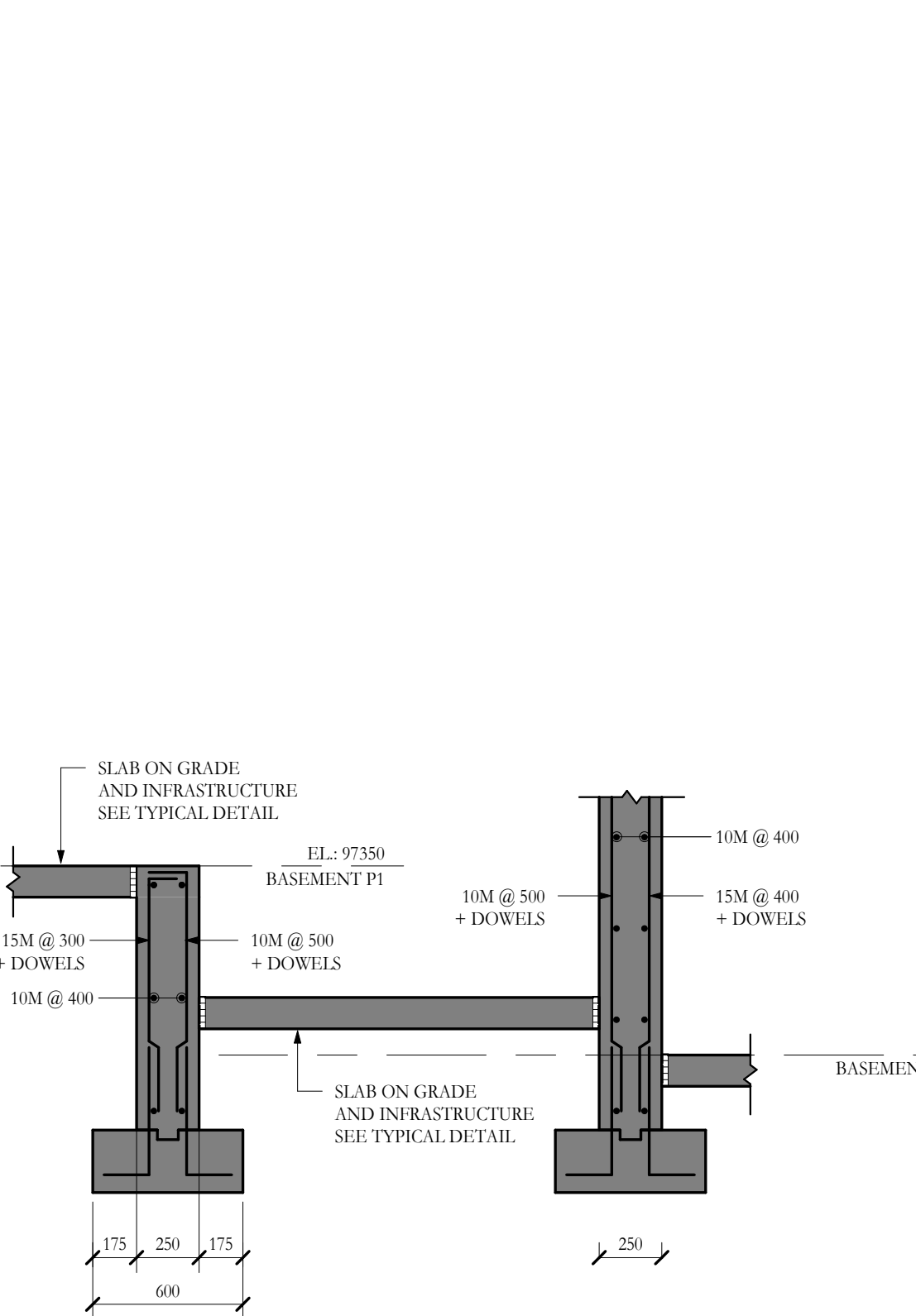

9 COUPE  
S-100A ECH: 1:25

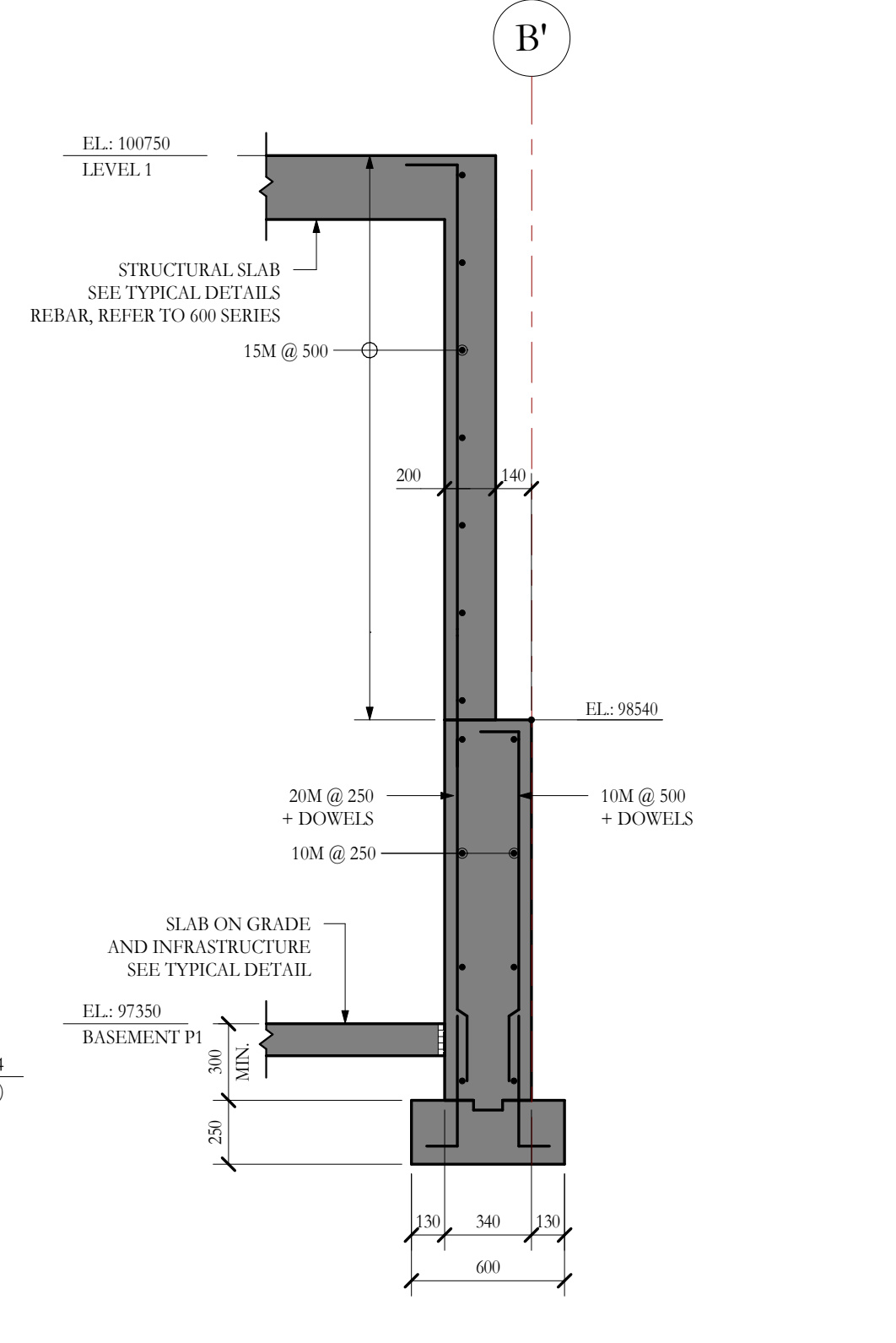

10 COUPE  
S-100A ECH: 1:25

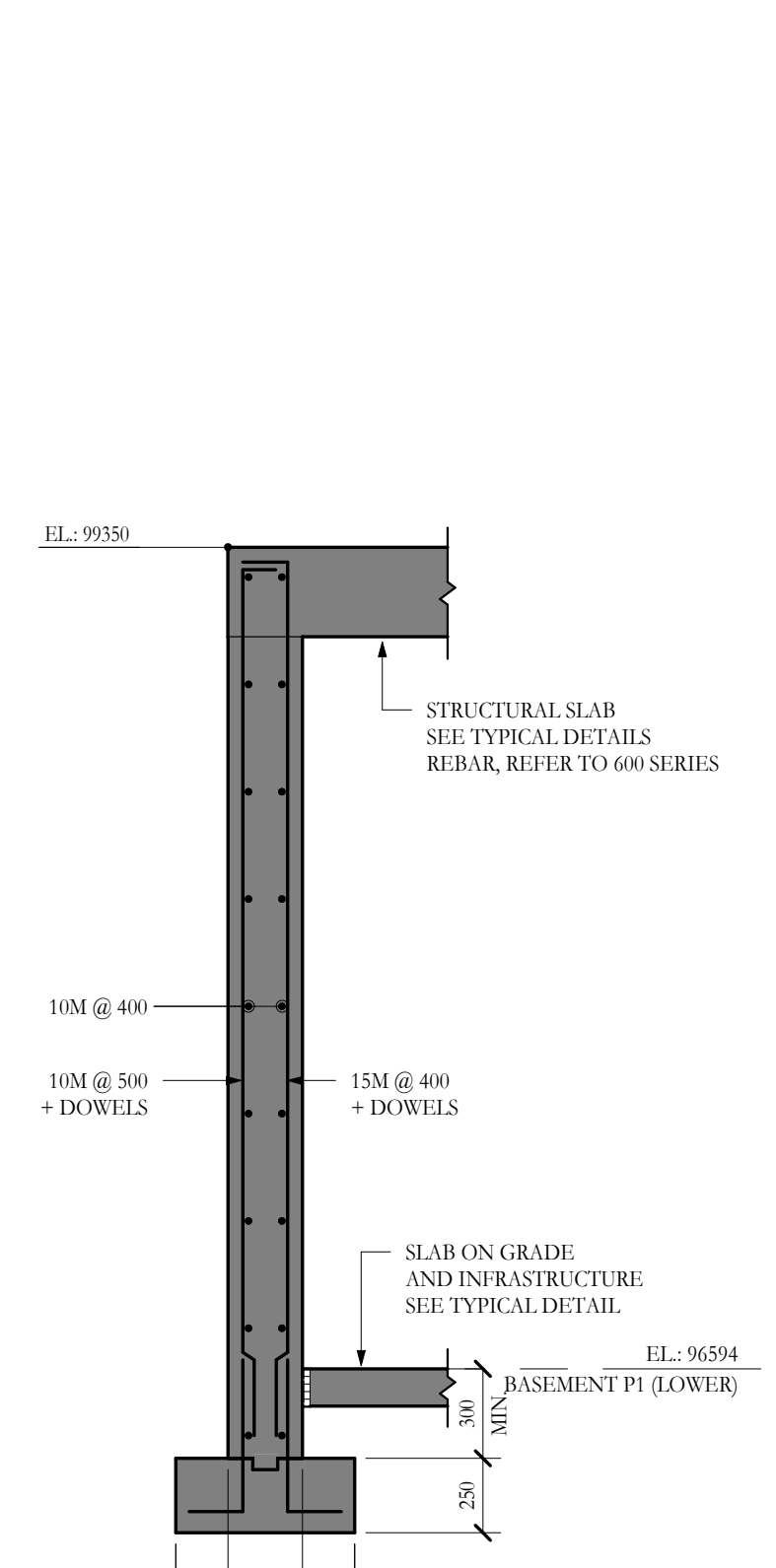

11 COUPE  
S-100A ECH: 1:25

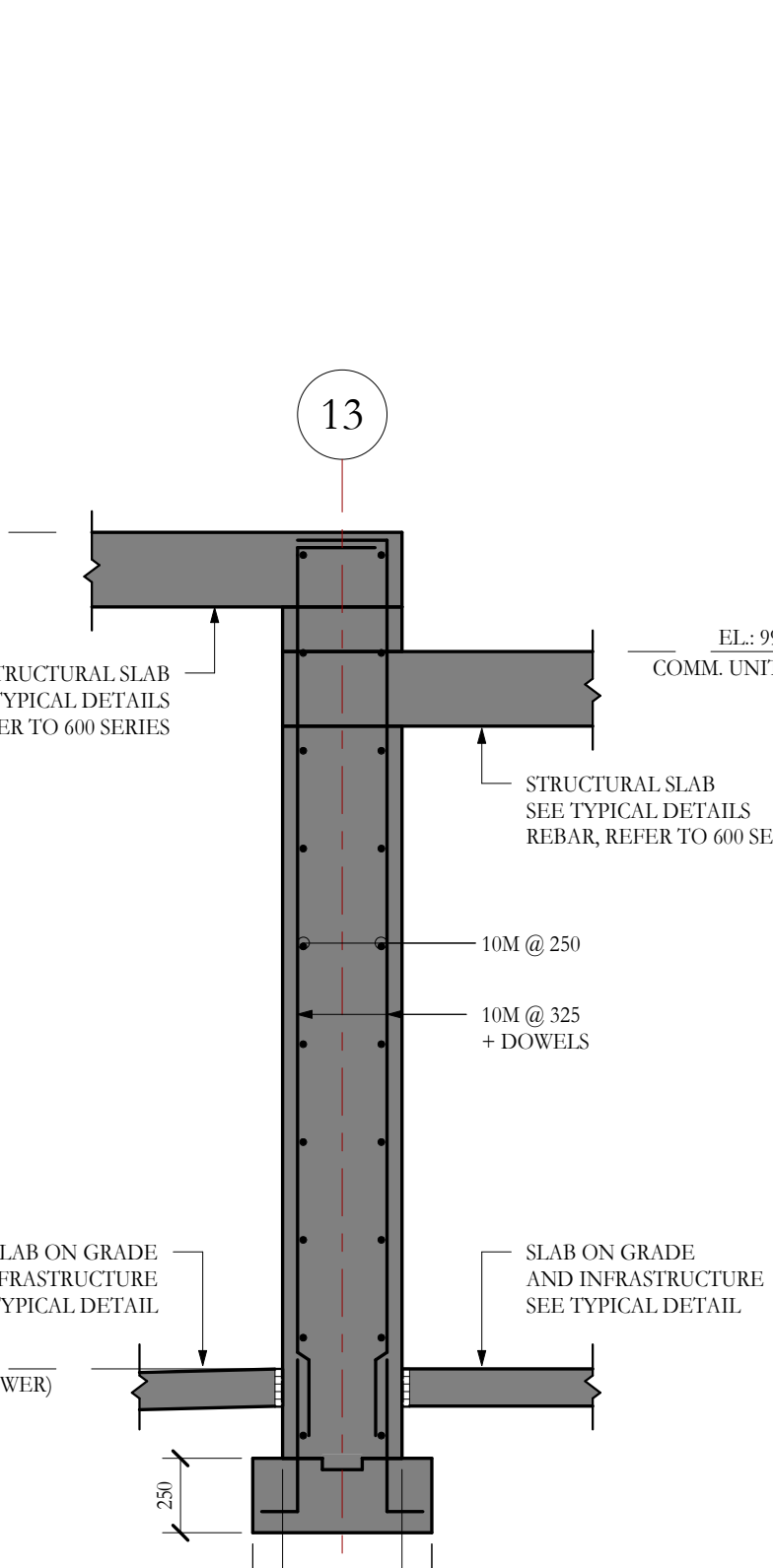

12 COUPE  
S-100A ECH: 1:25

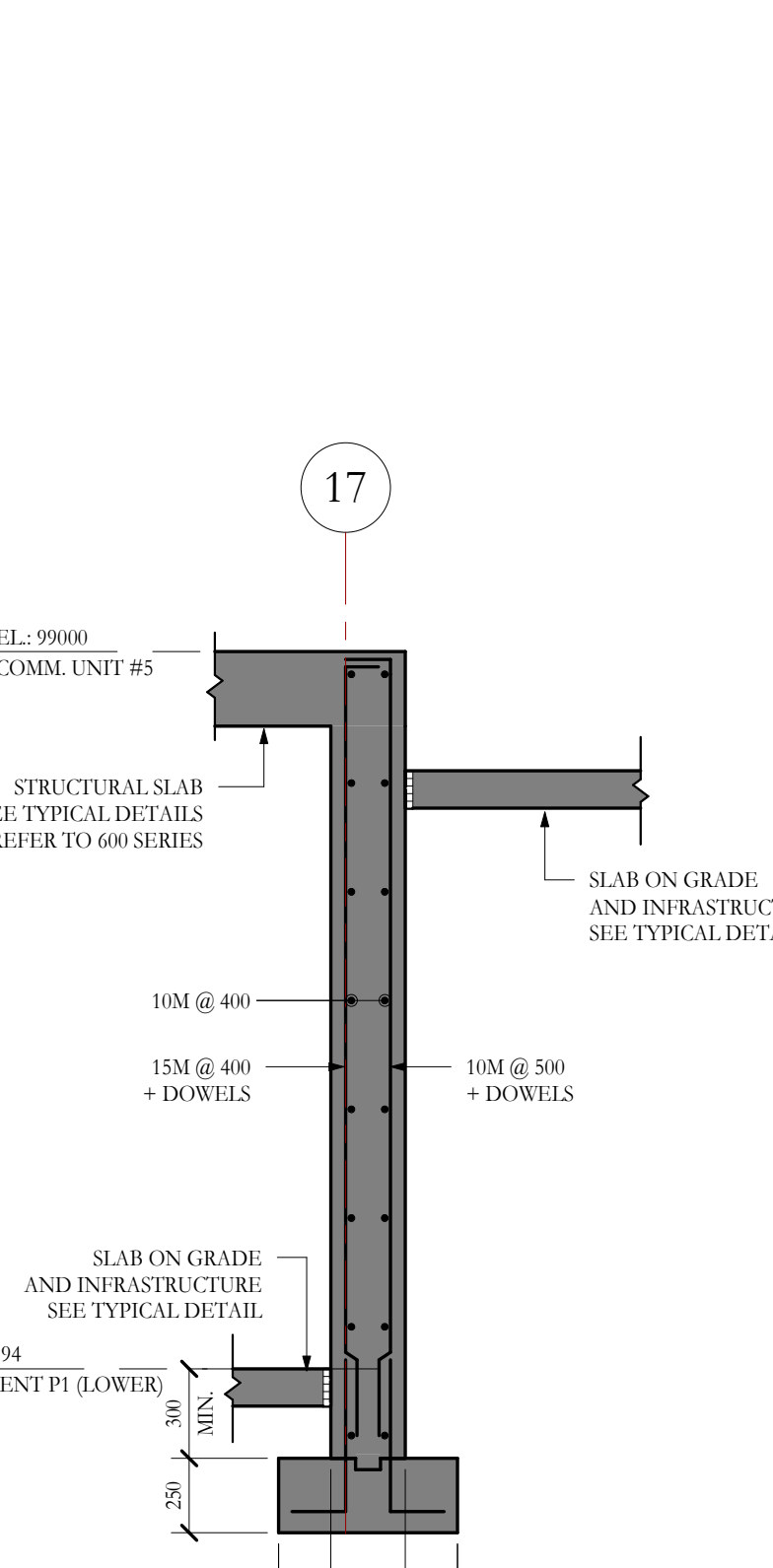

13 COUPE  
S-100A ECH: 1:25

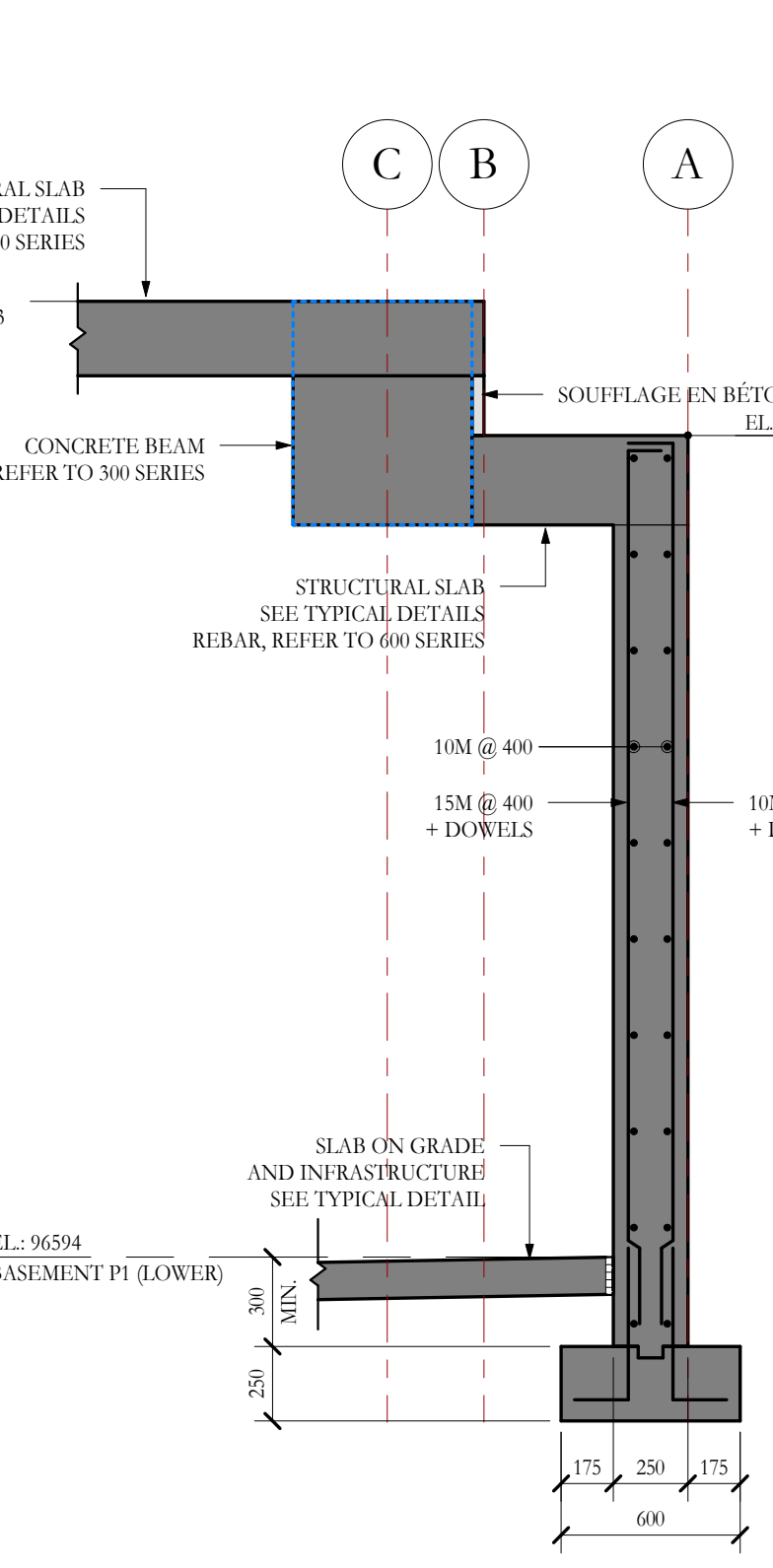

14 COUPE  
S-100A ECH: 1:25

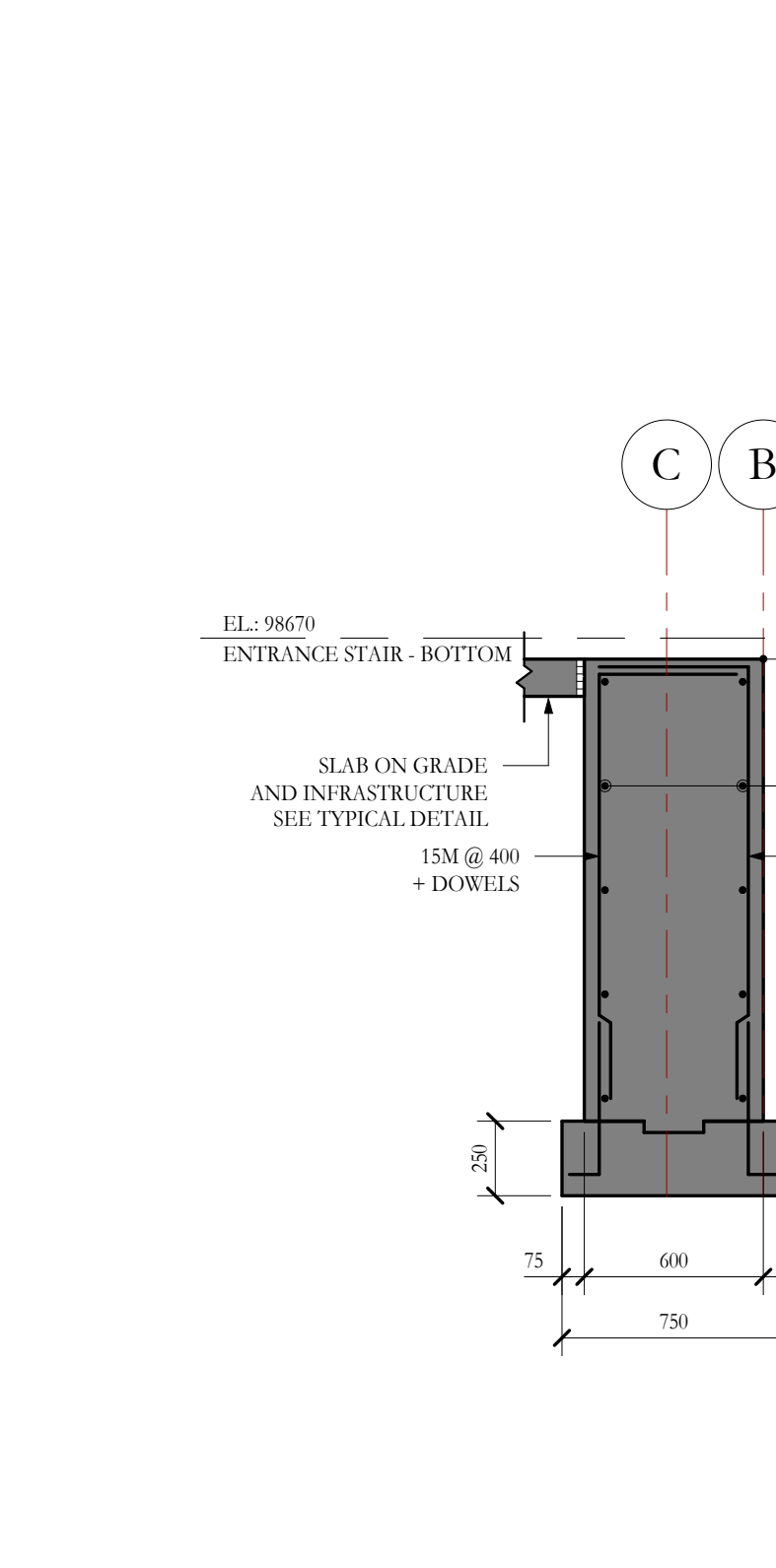

15 COUPE  
S-100A ECH: 1:25

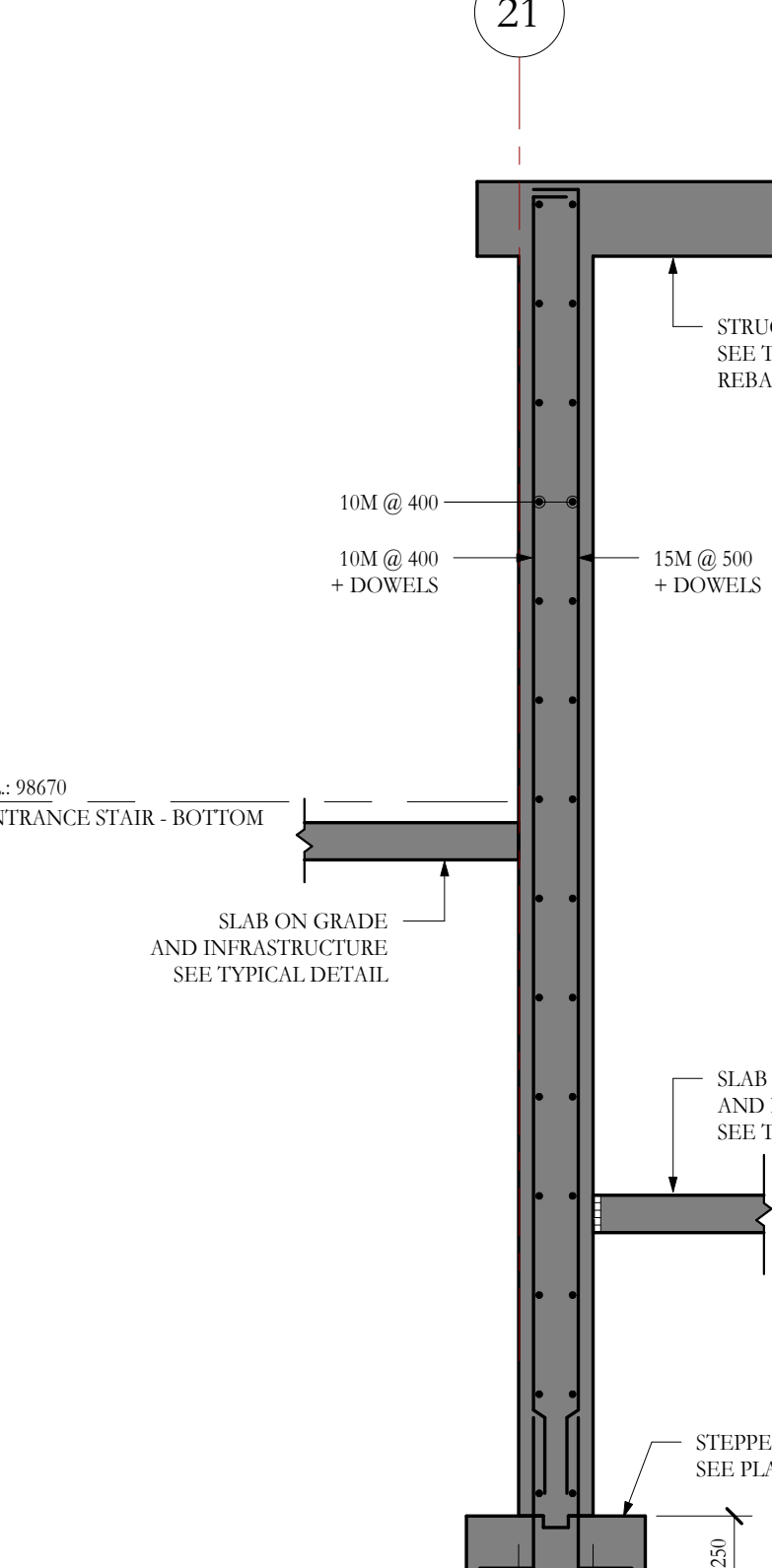

16 COUPE  
S-100A ECH: 1:25

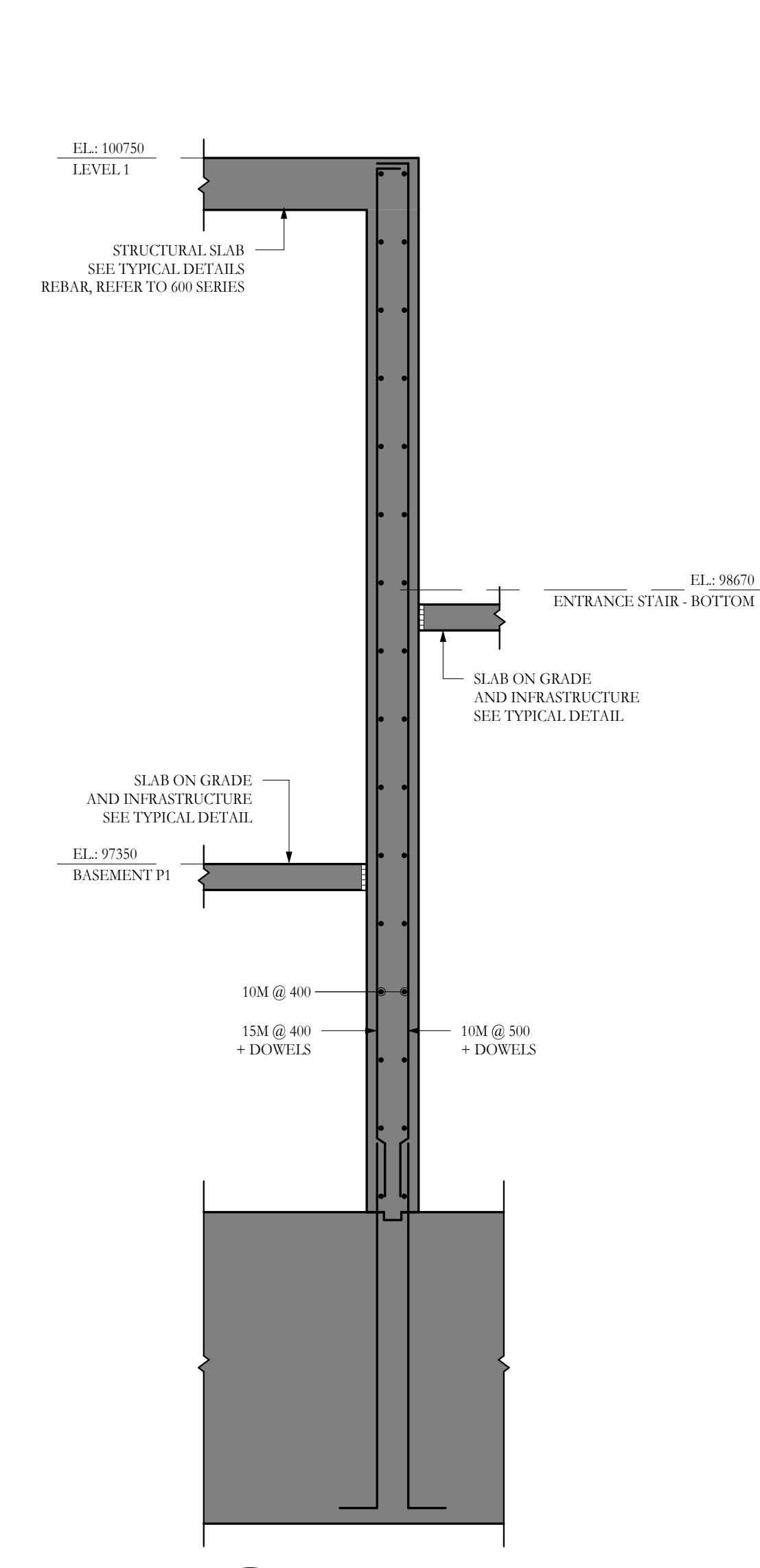

17 COUPE  
S-100A ECH: 1:25

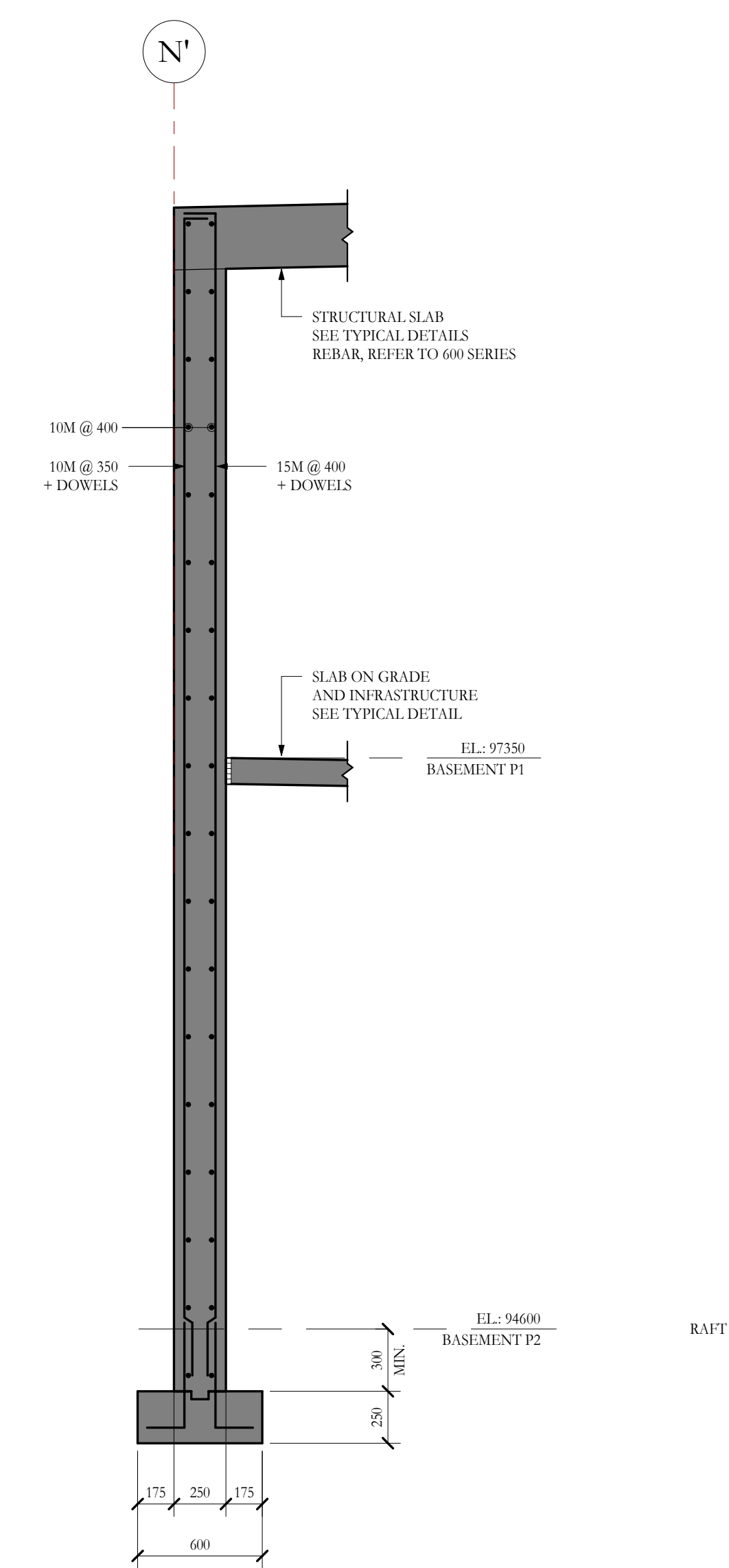

18 COUPE  
S-100A ECH: 1:25

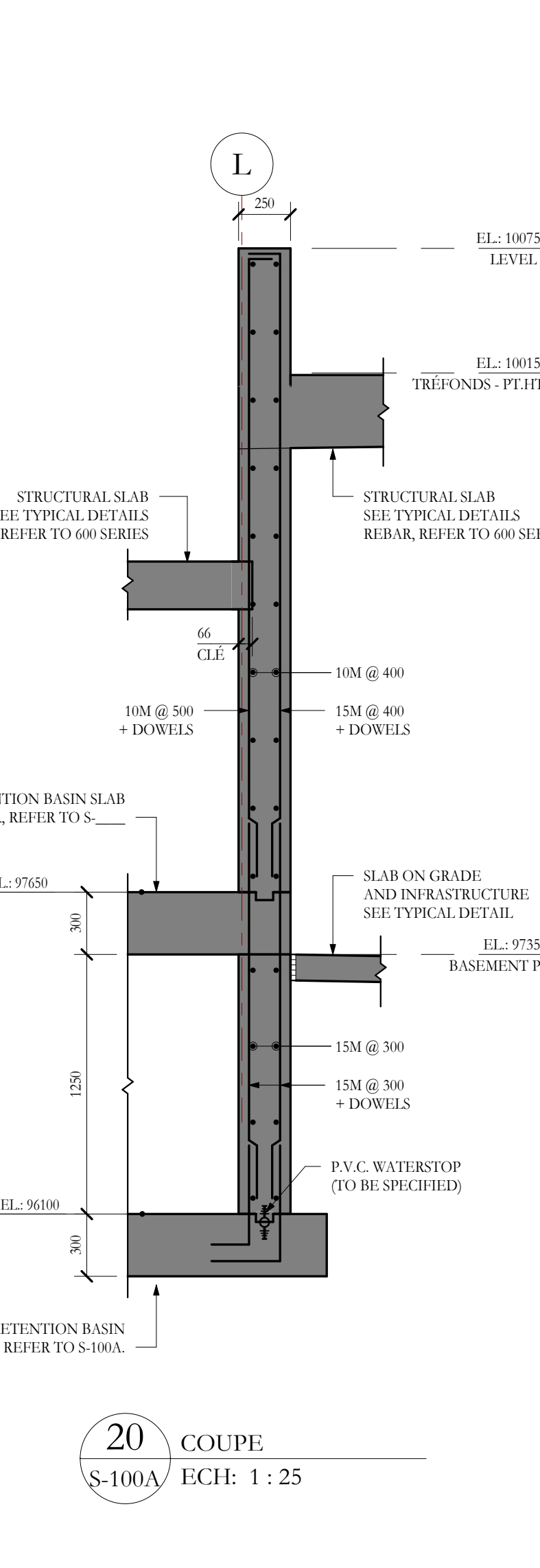

19 COUPE  
S-100A ECH: 1:25

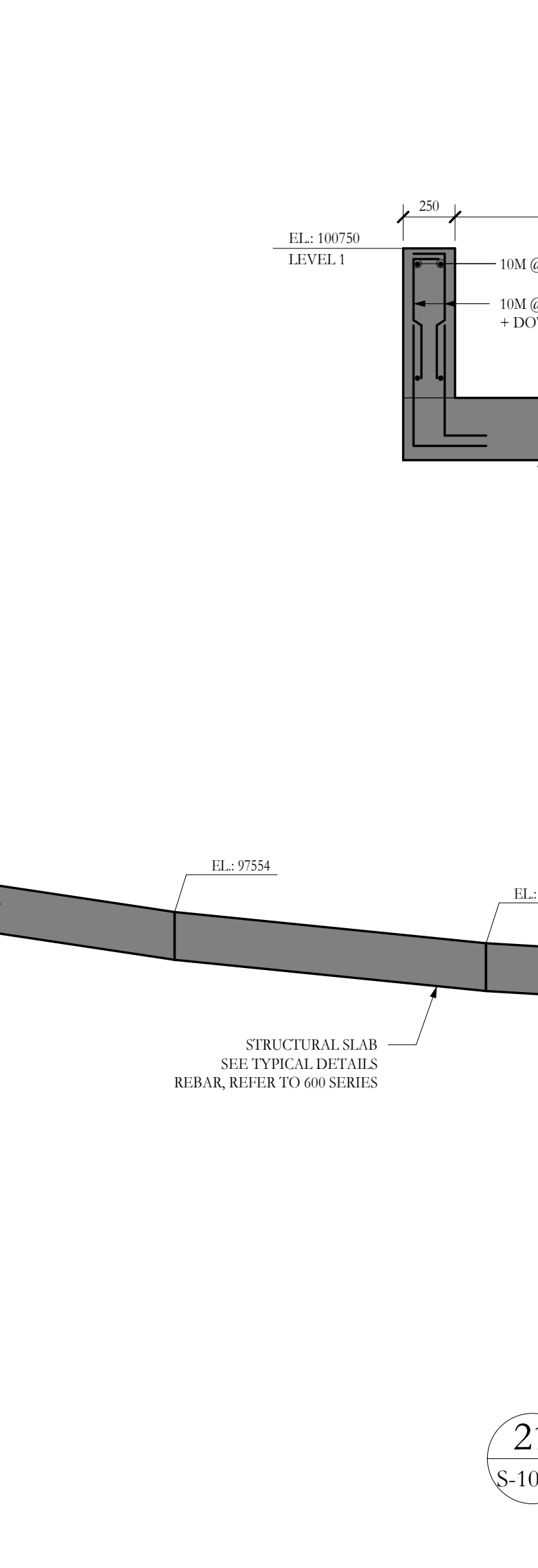

20 COUPE  
S-100A ECH: 1:25

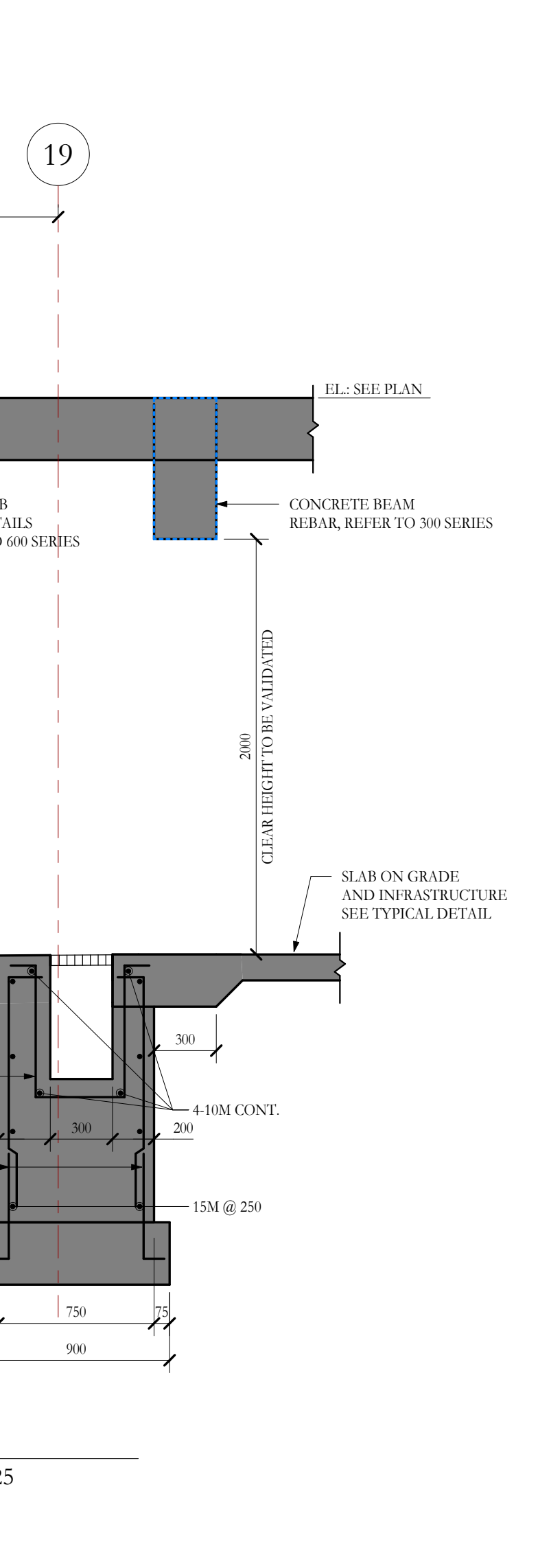

21 COUPE  
S-100A ECH: 1:25

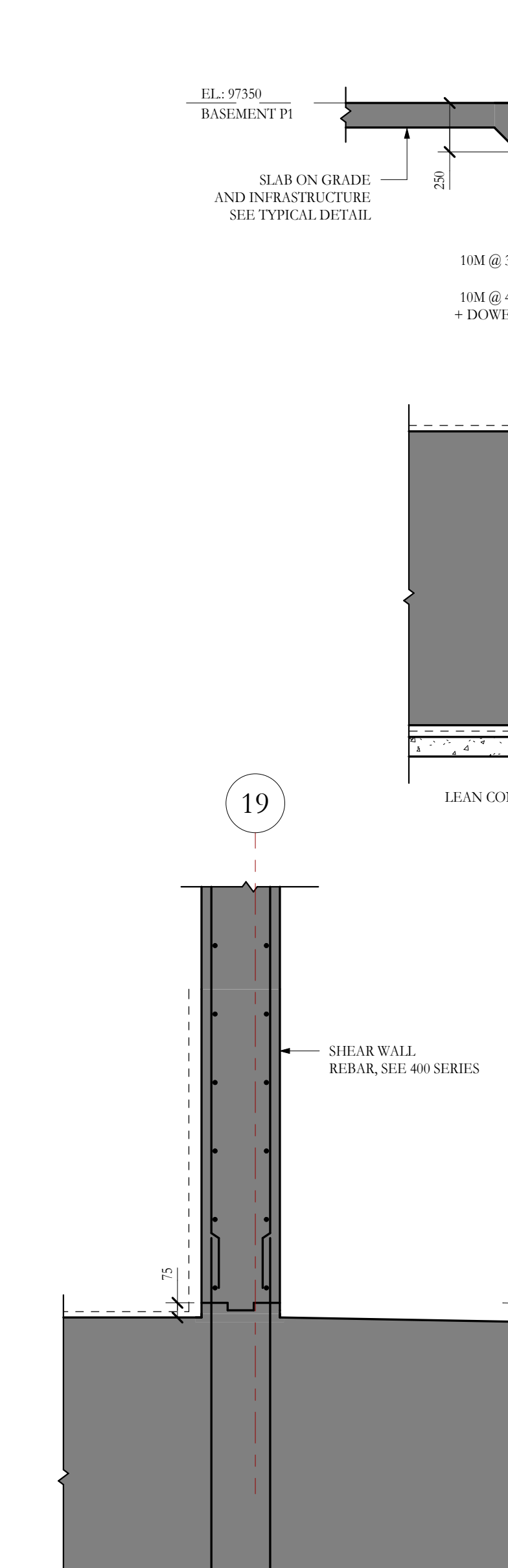

22 COUPE  
S-100A ECH: 1:25

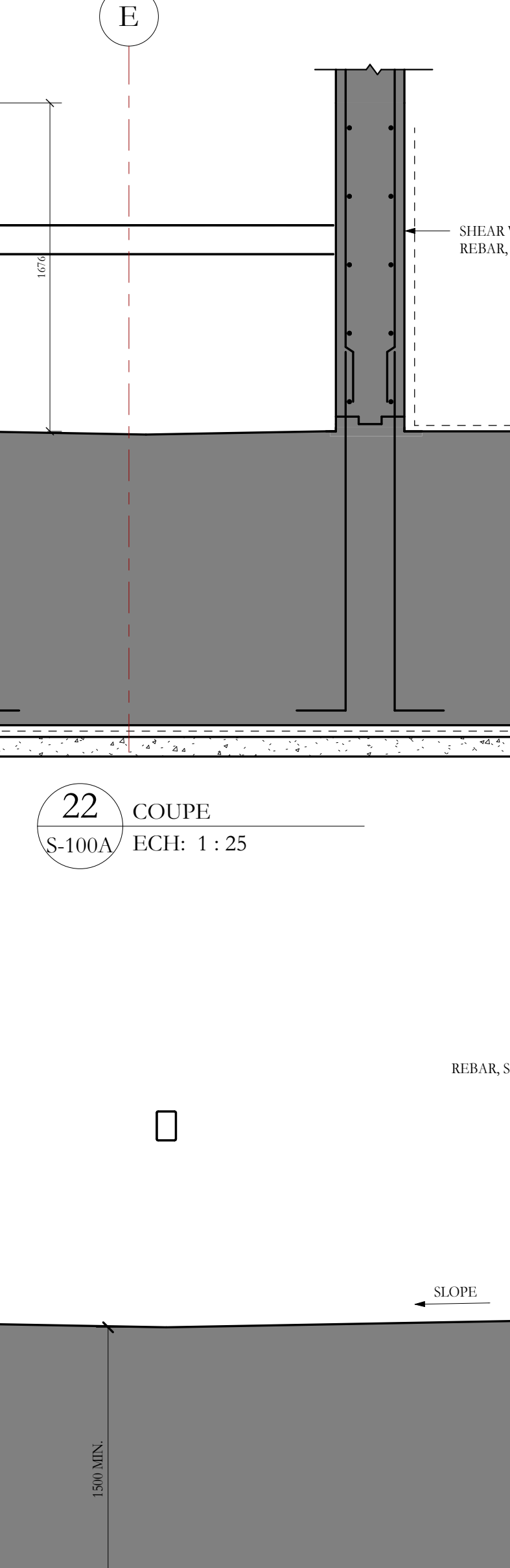

23 COUPE  
S-100A ECH: 1:25

REV	DATE	DESCRIPTION
1	2022-02-15	PLANS 3 FOURS - PHASE 1
2	2022-11-09	COORDINATION #1
3	2023-05-16	TENDER - PHASE 1
4	2023-05-07	PERMET - PHASE 1
5	2022-12-01	EMIS POUR SOUMISSION ARMATURES
6	2022-10-07	EMIS POUR SOUMISSION FONDATIONS

	<b>4710, RUE ST-AMBROISE</b> BUREAU 103 MONTREAL (QC) H4C 2C7 514 379-4999 <a href="http://www.l2c-experts.com">www.l2c-experts.com</a>
<b>PROJECT</b> EMD KANATA	
<b>DRAWING NAME</b> SECTION CUTS AND DETAILS - PHASE 1	
DRAWN BY: JONATHAN CULLEN	CONTRACT NO.: 120202004
DESIGNED BY: MARC-ANTOINE LAPLANTE, PH.D. (P. ENG.)	PLAN NO.: S-200
APPROVED BY: GILBERT GUYE, M. ENG. (P. ENG.)	

# Concrete Tank Design

Detail is from the structural plans S-200.

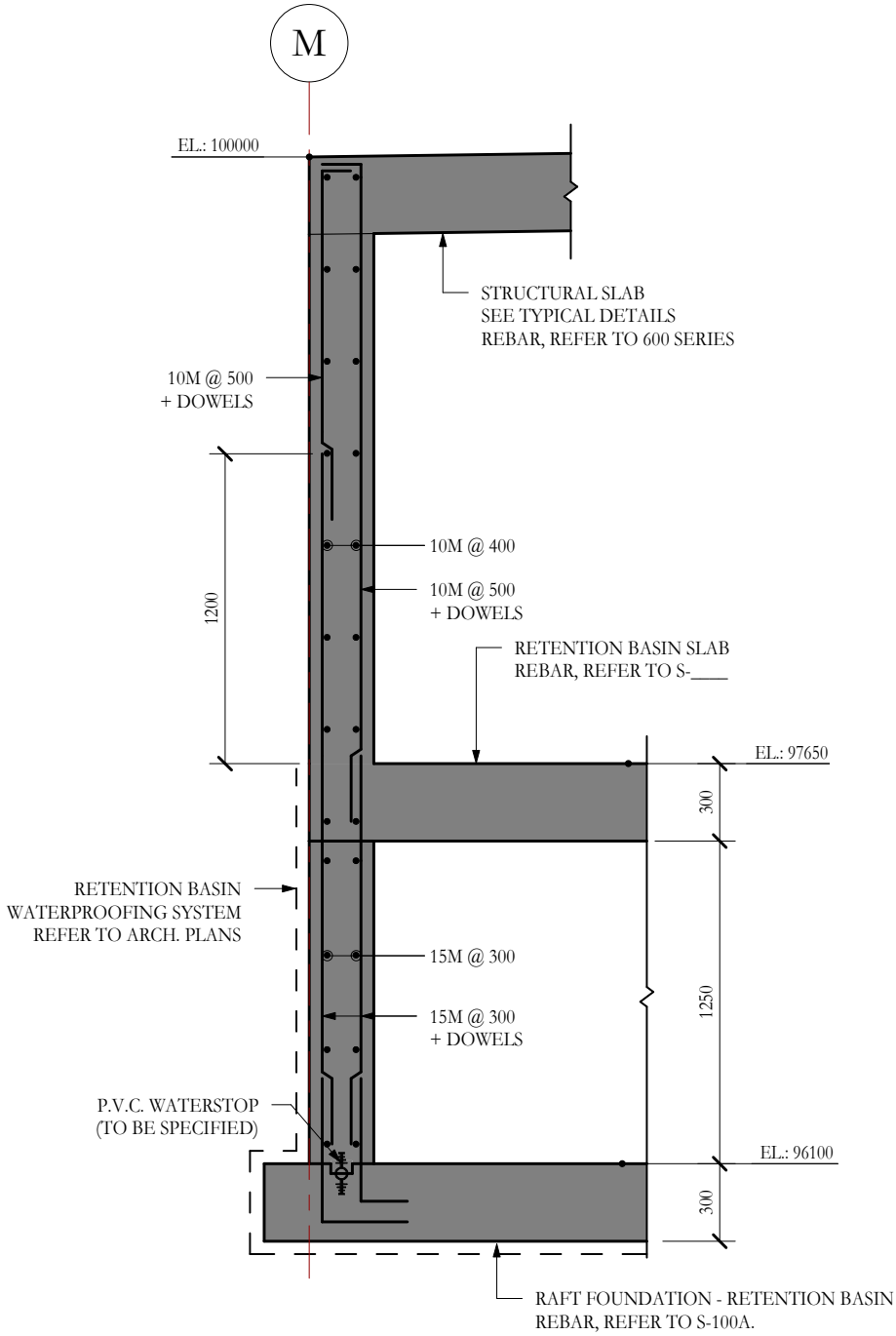

## PHASE 1

MAXIMUM WATER LEVEL: 97.350

TANK DIMENSION: HEIGHT: 55 300mm  
 WIDTH: 6 000mm  
 LENGTH: 1 250mm

MAXIMUM VOLUME: 415 m

CONCRETE TANK INVERT: 96.100  
 U.S.F.: 97.350

## PHASE 2

MAXIMUM WATER LEVEL: 94.600m

TANK DIMENSION: HEIGHT: 35 800mm  
 WIDTH: 6000mm  
 LENGTH: 1 000mm

MAXIMUM VOLUME: 215m

CONCRETE TANK INVERT: 93.600m  
 U.S.F.: 94.600m

3 COUPE  
 S-100A ECH: 1 : 25

### STORM SEWER CALCULATION SHEET (RATIONAL METHOD)

Manning' 0.013 Return 5 years

Location			Area (ha)			Flow				SEWER DATA										
Location	From Node	To Node	R= 0.25	R= 0.6	R= 0.9	indiv. 2.78 AC	Accum. 2.78 AC	Time of Conc.	Rainfall Intensity	Peak Flow Q (L/s)	DIA. (mm) (actual)	DIA. (mm) (nominal)	TYPE	SLOPE (%)	LENGTH (m)	CAPACITY (l/s)	VELOCITY (m/s)	TIME OF FLOW (min.)	RATIO Q/Qfull	
Phase 1	Building P1				0.37															
	CB-04		0.01		0.06															
	CB-05		0.00		0.06															
	CB-06		0.00		0.06															
	CB-07		0.00		0.04															
	CB-08		0.00		0.05															
	CB-09		0.01		0.06															
	CB-10		0.01		0.04															
Total Phase 1																				
	Building P1	ST-MH-05	0.02		0.75			30.00	53.90	66.60	366.40	375.00	PVC	0.91	1.10	157.14	1.49	0.01	0.42	
	ST-MH-05	ST-MH-06	0.02		0.75			30.00	53.90	66.60	366.40	375.00	PVC	0.26	59.13	84.38	0.80	1.23	0.79	
	ST-MH-06	ST-MH-07	0.02		0.75			30.00	53.90	66.60	366.40	375.00	PVC	0.19	18.35	71.98	0.68	0.45	0.93	
Phase 2	Building P2				0.37															
	CB-01		0.00		0.06															
	CB-02		0.00		0.06															
	CB-03		0.00		0.06															
Total Phase 2																				
	Building P2	ST-MH-04	0.00		0.33			145.00	16.80	6.00	299.40	300.00	PVC	1.00	1.00	96.19	1.37	0.01	0.06	
	ST-MH-04	ST-MH-03	0.00		0.33			145.00	16.80	6.00	299.40	300.00	PVC	0.43	11.70	62.88	0.89	0.22	0.10	
	ST-MH-03	ST-MH-02	0.00		0.33			145.00	16.80	6.00	299.40	300.00	PVC	0.55	14.58	71.25	1.01	0.24	0.08	
	ST-MH-02	ST-MH-01	0.00		0.33			145.00	16.80	6.00	299.40	300.00	PVC	0.54	11.08	70.78	1.01	0.18	0.08	
	ST-MH-01	Street	0.00		0.33			145.00	16.80	6.00	299.40	300.00	PVC	1.00	15.72	96.19	1.37	0.19	0.06	
Definitions: Q = 2.78 AIR, Where Q = Peak Flow in Litres per second (L/s) A = Area in Hectares (ha) I = Rainfall Intensity (L/s) R = Runoff Coefficient			Notes: 1) Ottawa Rainfall-Intensity Curve 2) Min Velocity = 0.76 m/sec			Designed: Benoit Bray, ing.		PROJECT: 150 Kanata												
						Checked:		LOCATION 150 Kanata												
						DWG Reference:		File Ref.:				Date:				Sheet No. 1 of 2				

## STORM SEWER CALCULATION SHEET (RATIONAL METHOD)

Manning' 0.013      Return 100 years

Location			Area (ha)			Flow				SEWER DATA									
			R= 0.25	R= 0.6	R= 0.9	indiv. 2.78 AC	Accum. 2.78 AC	Time of Conc.	Rainfall Intensity	Peak Flow Q (L/s)	DIA. (mm) (actual)	DIA. (mm) (nominal)	TYPE	SLOPE (%)	LENGTH (m)	CAPACITY (l/s)	VELOCITY (m/s)	TIME OF FLOW (min.)	RATIO Q/Qfull
Phase 1	Building P1				0.37														
	CB-04		0.01		0.06														
	CB-05		0.00		0.06														
	CB-06		0.00		0.06														
	CB-07		0.00		0.04														
	CB-08		0.00		0.05														
	CB-09		0.01		0.06														
	CB-10		0.01		0.04														
Total Phase 1																			
	Building P1	ST-MH-05	0.02		0.75		65.00	52.60	66.60	366.40	375.00	PVC	0.91	1.10	157.14	1.49	0.01	0.42	
	ST-MH-05	ST-MH-06	0.02		0.75		65.00	52.60	66.60	366.40	375.00	PVC	0.26	59.13	84.38	0.80	1.23	0.79	
	ST-MH-06	ST-MH-07	0.02		0.75		65.00	52.60	66.60	366.40	375.00	PVC	0.19	18.35	71.98	0.68	0.45	0.93	
Phase 2	Building P2				0.37														
	CB-01		0.00		0.06														
	CB-02		0.00		0.06														
	CB-03		0.00		0.06														
Total Phase 2																			
	Building P2	ST-MH-04	0.00		0.33		280.00	16.80	6.00	299.40	300.00	PVC	1.00	1.00	96.19	1.37	0.01	0.06	
	ST-MH-04	ST-MH-03	0.00		0.33		280.00	16.80	6.00	299.40	300.00	PVC	0.43	11.70	62.88	0.89	0.22	0.10	
	ST-MH-03	ST-MH-02	0.00		0.33		280.00	16.80	6.00	299.40	300.00	PVC	0.55	14.58	71.25	1.01	0.24	0.08	
	ST-MH-02	ST-MH-01	0.00		0.33		280.00	16.80	6.00	299.40	300.00	PVC	0.54	11.08	70.78	1.01	0.18	0.08	
	ST-MH-01	Street	0.00		0.33		280.00	16.80	6.00	299.40	300.00	PVC	1.00	15.72	96.19	1.37	0.19	0.06	
Definitions:			Notes:			Designed:		PROJECT: 150 Kanata											
Q = 2.78 AIR, Where			1) Ottawa Rainfall-Intensity Curve			Benoit Bray, ing.		LOCATION 150 Kanata											
Q = Peak Flow in Litres per second (L/s)			2) Min Velocity = 0.76 m/sec			Checked:													
A = Area in Hectares (ha)					DWG Reference:		File Ref.:				Date:				Sheet No.				
I = Rainfall Intensity (L/s)															2 of 2				
R = Runoff Coefficient																			

# FLOW CONTROL ROOF DRAINAGE DECLARATION

THIS FORM TO BE COMPLETED BY THE MECHANICAL AND STRUCTURAL ENGINEERS RESPONSIBLE FOR DESIGN

Permit Application No.

D07-12-21-0153

Project Name:

EMD Kanata

Building Location:

150 Kanata Avenue, Ottawa, ON, K2K 3L9

Municipality:

The roof drainage system has been designed in accordance with the following criteria: (please check one of the following).

- M1.  Conventionally drained roof (no flow control roof drains used).
- M2.  Flow control roof drains meeting the following conditions have been incorporated in this design:
- (a) the maximum drain down time does not exceed 24h,
  - (b) one or more scuppers are installed so that the maximum depth of water on the roof cannot exceed 150mm,
  - (c) drains are located not more than 15m from the edge of roof and not more than 30m from adjacent drains, and
  - (d) there is at least one drain for each 900 sq.m.
- M3.  A flow control drainage system that does not meet the minimum drainage criteria described in M2 has been incorporated in this design.

## PROFESSIONAL SEAL APPLIED BY:

Practitioner's Name:

Sébastien Soucy, P.Eng

Firm:

LRL Associates Ltd.

Phone #:

6132293015

City:

Ottawa

Province:

ON



Mechanical Engineer's Seal

- S1.  The design parameters incorporated into the overall structural design are consistent with the information provided by the Mechanical Engineer in M2. Loads due to rain are not considered to act simultaneously with loads due to snow as per Sentence 4.1.7.3 (3) OBC.
- S2.  The structure has been designed incorporating the additional structural loading due to rain acting simultaneously with the snow load. The design parameters are consistent with the control flow drainage system designed by the mechanical engineer.

## PROFESSIONAL SEAL APPLIED BY:

Practitioner's Name:

Jean-René Larose

Firm:

L2C

Phone #:

1-514-379-4999

City:

montreal

Province:

quebec



Structural Engineer's Seal

# APPENDIX D

Sanitary Sewer Design Flows

Detailed Calculations



## **SANITARY SEWER DESIGN FLOWS - PHASE 1**

**Reference :** Ottawa Sewer Design Guidelines, *Infrastructure Services Department*, October 2012

### ***A. Population Density***

<i>(Article 4.3, Table 4.2)</i>	Number of units	Persons Per Unit	Population Density
1-bedroom	149	1.4	208.6
2-bedroom	71	2.1	149.1
3-bedroom	16	3.1	49.6
Total population density:			407

### ***B. Average Wastewater Flows***

*(Article 4.4.1, Figure 4.3)*

Average wastewater flow per capita for residential use:	280 L/c/d
Average wastewater flow for residential use:	114 044 L/d
Average wastewater flow for commercial use:	28 000 L/gross ha/d
Commercial Areas: 1214 m <sup>2</sup>	3 399 L/d

### ***C. Peaking Factors***

*(Article 4.4.1, Figure 4.3)*

Residential peak factor: Harmon Equation  
 K=1

$$P.F. = 1 + \left( \frac{14}{4 + \left( \frac{P}{1000} \right)^{1/2}} \right) \times K$$

Residential peak factor: 4.02  
 Commercial peak factor: 1.50

### ***D. Extraneous Flows***

*(Article 4.4.1.4)*

Infiltration allowance:	0.33	L/s/effective gross ha	for 1.490 ha
Infiltration flow:	0.49	L/s	

### ***F. Total Wastewater Design Flow***

$$Q_{\text{design}} = [(4.02 \times 114\,044 \text{ L/d}) + (1.50 \times 3\,399 \text{ L/d})] \times 1/86\,400 \text{ sec/d} + 0.49 \text{ L/s}$$

$$Q_{\text{design}} = 5.85 \text{ L/s}$$





## SANITARY SEWER DESIGN FLOWS - PHASE 2

**Reference :** Ottawa Sewer Design Guidelines, *Infrastructure Services Department*, October 2012

### A. Population Density

(Article 4.3, Table 4.2)	Number of units	Persons Per Unit	Population Density
1-bedroom	83	1.4	116.2
2-bedroom	68	2.1	142.8
3-bedroom	14	3.1	43.4
Total population density:			302

### B. Average Wastewater Flows

(Article 4.4.1, Figure 4.3)

Average wastewater flow per capita for residential use:	280 L/c/d
Average wastewater flow for residential use:	84 672 L/d
Average wastewater flow for commercial use:	28 000 L/gross ha/d
Commercial Areas: 0 m <sup>2</sup>	0 L/d

### C. Peaking Factors

(Article 4.4.1, Figure 4.3)

Residential peak factor: Harmon Equation  
 K=1

$$P.F. = 1 + \left( \frac{14}{4 + \left( \frac{P}{1000} \right)^{1/2}} \right) \times K$$

Residential peak factor: 4.08  
 Commercial peak factor: 1.50

### D. Extraneous Flows

(Article 4.4.1.4)

Infiltration allowance:	0.33	L/s/effective gross ha	for 1.490 ha
Infiltration flow:	0	L/s	

### F. Total Wastewater Design Flow

$$Q_{\text{design}} = [(4.08 \times 84\,672 \text{ L/d}) + (1.50 \times 0 \text{ L/d})] \times 1/86\,400 \text{ sec/d} + 0 \text{ L/s}$$

$$Q_{\text{design}} = 4.00 \text{ L/s}$$

# SANITARY SEWER CALCULATION SHEET



Manning's n = 0,013

LOCATION			RESIDENTIAL AREA AND POPULATION					COMM		INDUST			INST		C+H	INFILTRATION			PIPE								
STREET	FROM M.H.	TO M.H.	AREA (ha)	POP.	CUMULATIVE AREA (ha)	POP.	PEAK FACT.	PEAK FLOW (l/s)	AREA (ha)	ACCU. AREA (ha)	AREA (ha)	ACCU. AREA (ha)	PEAK FACTOR (per 1000)	AREA (ha)	ACCU. AREA (ha)	PEAK FLOW (l/s)	TOTAL AREA (ha)	ACCU. AREA (ha)	INFILT. FLOW (l/s)	TOTAL FLOW (l/s)	LENGTH (m)	DIA. (mm)	SLOPE (%)	CAP. (FULL) (l/s)	VEL. (FULL) (m/s)		
New Street	BUILD. PHASE 1	SAN-MH-01		407			4.02	5.30	0.1214	0.1214	-	-	1.5	-	-	0.0590	1.49		0.49	5.85	1.00	250	1.00	59.47	1.21		
New Street	SAN-MH-01	SAN-MH-02																		5.85	35.90	250	0.33	34.16	0.70		
Maritime Way	BUILD. PHASE 2	SAN-MH-03		302			4.08	3.99	-	-	-	-	-	-	-	-	-		-	3.99	1.00	250	1.00	59.47	1.21		
Maritime Way	SAN-MH-03	E-SAN-MH-05																		3.99	21.90	250	2.02	84.52	1.72		
DESIGN PARAMETERS															Designed:		PROJECT: LIB KANATA										
Average Daily Flow = 280 l/p/day Comm/Inst Flow = 28000 L/ha/da Industrial Flow = 28000 L/ha/da Max Res. Peak Factor = 4.08 Commercial / Inst Peak Factor = 1.50																	LOCATION: KANATA AVENUE AND MARITIME WAY, OTTAWA, ON										
Industrial Peak Factor = as per MOE Graph Extraneous Flow = 0.33 L/s/ha Minimum Velocity = 0.86 m/s Manning's n = 0,013															Checked:		Dwg. Reference: C-204			File Ref.: 600401		Date: 2023-01-24		Sheet No. 1 of 1			

## SANITARY PIPE ANALYSIS

Upstream Location	Downstream Location	Diameter (d)	Type	Upstream invert	Downstream Invert	Length (m)	Slope (%)	Capacity (Qf) (L/s)	Velocity full (Vf) (m/s)	Flowrate (Q) (L/s)	Q/Qf	y/D	Velocity (m/s)
Building - Phase 1	SAN-MH-01	250	PVC DR-35	95.200	95.190	1.00	1.00	59.47	1.21	5.85	0.10	0.30	0.73
SAN-MH-01	SAN-MH-02	250	PVC DR-35	95.130	95.010	35.90	0.33	34.38	0.70	5.85	0.17	0.35	0.46
Building - Phase 2	SAN-MH-03	250	PVC DR-35	94.300	94.290	1.00	1.00	59.47	1.21	3.99	0.07	0.22	0.61
SAN-MH-03	E-SAN-MH-05	250	PVC DR-35	94.290	93.850	21.90	2.01	84.29	1.72	3.99	0.05	0.18	0.76

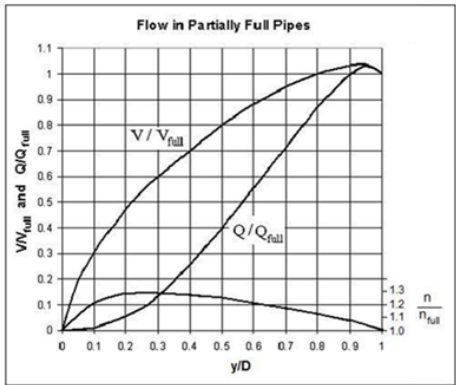

# APPENDIX E

Domestic Water Demand

Detailed Calculations

Watermain Pressure



## DOMESTIC WATER DEMAND CALCULATION

**Reference :** Ottawa Design Guidelines - Water Distribution, *Infrastructure Services department*, July 2010

### A. Population Density

<i>(Article 4.2.8, Table 4.1)</i>	Number of rooms	Persons Per Unit	Population Density
1-bedroom	222	1,4	310,8
2-bedroom	152	2,1	319,2
3-bedroom	24	3,1	74,4
		Total population density:	704

### B. Average Day Demand

*(Article 4.2.8, Table 4.2)*

Average day demand per capita for residential use:		280 L/c/d	
Average day demand for residential use:		197 232 L/d	
Average day demand for other commercial use:		28 000 L/gross ha/d	
Commercial Areas:	1214 m <sup>2</sup>	3 399 L/d	
Total average day demand:		200 631 L/d	= 2,32 L/s

### C. Maximum Daily Demand

*(Article 4.2.8, Table 4.2)*

$$\begin{aligned}
 \text{Maximum daily demand} &= 2.5 \times 196\,252 \text{ L/d} + 1.5 \times 3\,399 \text{ L/d} \\
 &= 490\,630 \text{ L/d} + 5\,099 \text{ L/d} \\
 &= 498\,179 \text{ L/d} \\
 &= 5,77 \text{ L/s}
 \end{aligned}$$

### D. Maximum Hour Demand

*(Article 4.2.8, Table 4.2 and Technical Bulletin ISD-2010-2)*

$$\begin{aligned}
 \text{Maximum hour demand} &= 2.2 \times (\text{Max Day}_{\text{res}}) \text{ L/d} + 1.8 \times (\text{Max Day}_{\text{com}}) \text{ L/d} \\
 \text{Maximum hour demand} &= 2.2 \times 490\,630 \text{ L/d} + 1.8 \times 5\,099 \text{ L/d} \\
 &= 1\,093\,954 \text{ L/d} \\
 &= 12,66 \text{ L/s}
 \end{aligned}$$

### F. Results

Population density =	704	people
Average day demand =	2,32	L/s
Maximum daily demand =	5,77	L/s
Maximum hour demand =	12,66	L/s



PVC Pipe

Section #1 : Dynamic pressure test point - junction FD 600mmØ / PVC DR-18 200mmØ

**Hypotheses:**

Material: Ductile Iron  
 Nominal diameter: 600 mm  
 Internal diameter: 633.7 mm  
 max flow (fire/daily): 2049.87 UsGPM, or 0.1293 m<sup>3</sup>/s  
 Pipe area: 0.3154 m<sup>2</sup>  
 Velocity: 0.4100 m/s

**Known information :**

Elevation at (1): 96.600 m  
 Dynamic pressure: 81.4 psi, or 57.24 m  
 max flow (fire/daily): 2049.87 UsGPM, or 0.1293 m<sup>3</sup>/s

**1 - Informations at (2) :**

Hazen-Williams Equation : 
$$H_f = 10,654 \times \left(\frac{Q}{C}\right)^{1.85} \times \left(\frac{1}{D^{4.87}}\right) \times L$$

Q = flowrate (m<sup>3</sup>/s)  
 C = coefficient 80 for corroded ductile iron pipe  
 D = internal diameter (m)  
 L = length (m)  
 H<sub>f</sub> = friction losses (m)

max flow (fire/daily): 2049.87 UsGPM, or 0.1293 m<sup>3</sup>/s  
 Length between (1) and (2): 47.500 m  
 Elevation at (2): 95.500 m  
 H<sub>s</sub>: -1.100 m  
 H<sub>f</sub>: 0.032 m  
 H<sub>sing</sub>: 0.5 m  
 H<sub>t</sub>: -0.568 m  
 Pressur at (2): 57.812 m, or 82.21 psi





# APPENDIX F

Required Fire Demand  
Detailed Calculations





## REQUIRED FIRE DEMAND CALCULATION

**References :** Ottawa Technical Bulletin ISTB-2018-02, March 2018  
 Water Supply for Public Fire Protection, 2020

### A. Type of construction

Non-combustible construction :  $C = 0.8$

### B. Total Floor Area

	Surface Area Per Floor	Number of Floors	Floor Area
Ground Floor	5 106 m <sup>2</sup>	1	5 106 m <sup>2</sup>
Levels 2-3*	4 386 m <sup>2</sup>	2	2 193 m <sup>2</sup>
Levels 4-7	3 958 m <sup>2</sup>	4	0 m <sup>2</sup>
Levels 8-9	3 442 m <sup>2</sup>	2	0 m <sup>2</sup>
Level 10-11	1 377 m <sup>2</sup>	2	0 m <sup>2</sup>
<i>Effective Area (A) =</i>			7 299 m <sup>2</sup>

As per the 2020 regulations for the Water Supply for Public Fire Protection in Canada, the total effective area (A) is to be calculated as the largest floor with the addition of 25% of the next 2 adjacent floors.

### D. Base Fire Flow

$$F = 220 \times C\sqrt{A} = 15\,036 \text{ L/min}$$

The base fire flow must be rounded up to the nearest 1,000 L/min, hence :  $F = 15\,000 \text{ L/min}$

### Fire Flow Adjustments

#### E. Building occupancy (adjustments to the value obtained in D)

Occupancy : Limited Combustible -15%  $F = 12\,750 \text{ L/min}$  ①

#### F. Automatic sprinkler system (adjustments to the value obtained in E)

NPFA 13 Designed system:	Yes	-30%
Standard water supply:	Yes	-10%
Fully supervised system:	Yes	-10%

#### G. Exposure surcharge (adjustments to the value obtained in E)

Length-Height Factors (no impact on exposure surcharge calculations since distances > 30m)

North side >45m 0%



East side	30+m	5%
South side	>45m	0%
West side	>45m	0%

Reductions from D = -50% = -6 375 L/min ②

Increases from E.3 = 5% = 638 L/min ③

① + ② + ③  $F = 7\ 013$  L/min

The fire flow must be rounded up to the nearest 1,000 L/min, hence :  $F = 7\ 000$  L/min

***F. volume of Water Required During the Fire***

The duration of water supply for a fire is: 2 hours

Required Volume = 840 000 L = 840 m<sup>3</sup>

**Fire Demand = 7 000 L/min      Required Volume = 840 m<sup>3</sup>**

# **APPENDIX G**

manufactured product specifications

# Engineering Specification

Job Name \_\_\_\_\_

Contractor \_\_\_\_\_

Job Location \_\_\_\_\_

Approval \_\_\_\_\_

Engineer \_\_\_\_\_

Contractor's P.O. No. \_\_\_\_\_

Approval \_\_\_\_\_

Representative \_\_\_\_\_

Tag \_\_\_\_\_

## RD-200-CP-85

### IRMA Roof Drain with 8"x8"

### Promenade Top

#### Specification

Watts RD-200-CP-85 epoxy coated cast iron IRMA roof drain with flashing clamp, 4"(102) high stainless steel perforated extension, 8"x8"(203x203) square heel proof epoxy coated ductile promenade top and no hub (standard) outlet.

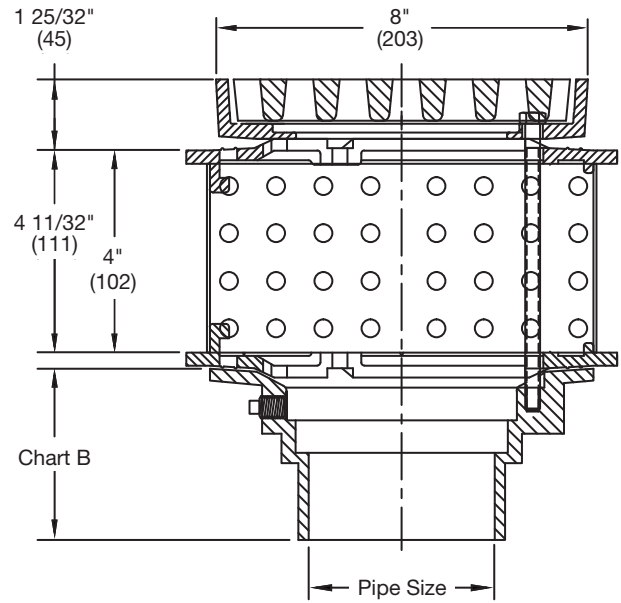

Pipe Size	
Suffix	Description
2	2"(51) Pipe Size <input type="checkbox"/>
3	3"(76) Pipe Size <input type="checkbox"/>
4	4"(102) Pipe Size (NH Only) <input type="checkbox"/>

Outlet Type	
Suffix	Description
NH	No Hub (MJ) <input type="checkbox"/>
P	Push On <input type="checkbox"/>
T	Threaded Outlet <input type="checkbox"/>
X	Inside Caulk <input type="checkbox"/>

Options	
Suffix	Description
-1	All Nickel Bronze Top <input type="checkbox"/>
-5	Sediment Bucket <input type="checkbox"/>
-6	Vandal Proof Top <input type="checkbox"/>
-9	Hinged Grate <input type="checkbox"/>
-13	Galvanized <input type="checkbox"/>
-B	Sump Receiver <input type="checkbox"/>
-D	Underdeck Clamp <input type="checkbox"/>
-F	Deck Flange/Adj. Extension <input type="checkbox"/>
-SO	Side Outlet <input type="checkbox"/>

Optional Body Material	
Suffix	Description
-60	PVC Body w/Socket Outlet <input type="checkbox"/>
-61	ABS Body w/Socket Outlet <input type="checkbox"/>

Load Rating	Free Area Sq. In.
MD*	41

**Deck Opening 10"(254)  
with sump receiver 13 1/4"(337)**

#### NOTICE

The load classifications are in accordance with the American National Standards ASME A112.6.3 ASME Ratings are as follows:  
 \*MD - Safe Live Load 2000-4999 lbs.(900-2250 kg.)  
 The above categories are given as a guide only. Please consult factory.

#### NOTICE

The information contained herein is not intended to replace the full product installation and safety information available or the experience of a trained product installer. You are required to thoroughly read all installation instructions and product safety information before beginning the installation of this product.

Watts product specifications in U.S. customary units and metric are approximate and are provided for reference only. For precise measurements, please contact Watts Technical Service. Watts reserves the right to change or modify product design, construction, specifications, or materials without prior notice and without incurring any obligation to make such changes and modifications on Watts products previously or subsequently sold.



**USA:** T: (800) 338-2581 • F: (828) 248-3929 • Watts.com  
**Canada:** T: (888) 208-8927 • F: (905) 481-2316 • Watts.ca  
**Latin America:** T: (52) 55-4122-0138 • Watts.com

# Engineering Specification

Job Name \_\_\_\_\_

Contractor \_\_\_\_\_

Job Location \_\_\_\_\_

Approval \_\_\_\_\_

Engineer \_\_\_\_\_

Contractor's P.O. No. \_\_\_\_\_

Approval \_\_\_\_\_

Representative \_\_\_\_\_

Tag \_\_\_\_\_

## RD-300-CP15-85 IRMA Roof Drain with 15"x15" Promenade Top

### Specification

Watts RD-300-CP15-85 epoxy coated cast iron IRMA roof drain with flashing flange with seepage openings, 15 5/8"x15 5/8"(397x397) square epoxy coated ductile iron heel proof promenade top, and no hub (standard) outlet.

Pipe Sizing		
Suffix	Description	
2	2"(51) Pipe Size (NH Only)	<input type="checkbox"/>
3	3"(76) Pipe Size	<input type="checkbox"/>
4	4"(102) Pipe Size	<input type="checkbox"/>
5	5"(127) Pipe Size (NH Only)	<input type="checkbox"/>
6	6"(152) Pipe Size	<input type="checkbox"/>
8	8"(203) Pipe Size	<input type="checkbox"/>
10	10"(254) Pipe Size (NH Only)	<input type="checkbox"/>



Outlet Type		
Suffix	Description	
NH	No Hub (MJ)	<input type="checkbox"/>
P	Push On	<input type="checkbox"/>
X	Inside Caulk	<input type="checkbox"/>

Options		
Suffix	Description	
-1	All Nickel Bronze Top	<input type="checkbox"/>
-6	Vandal Proof Top	<input type="checkbox"/>
-9	Hinged Grate	<input type="checkbox"/>
-13	Galvanized	<input type="checkbox"/>
-B	Sump Receiver	<input type="checkbox"/>
-D	Underdeck Clamp	<input type="checkbox"/>
-F	Deck Flange/Adj. Extension	<input type="checkbox"/>

Load Rating	Free Area Sq. In.
MD*	57

**Deck Opening 14 1/2"(368)  
with Sump Receiver 18"(457)**

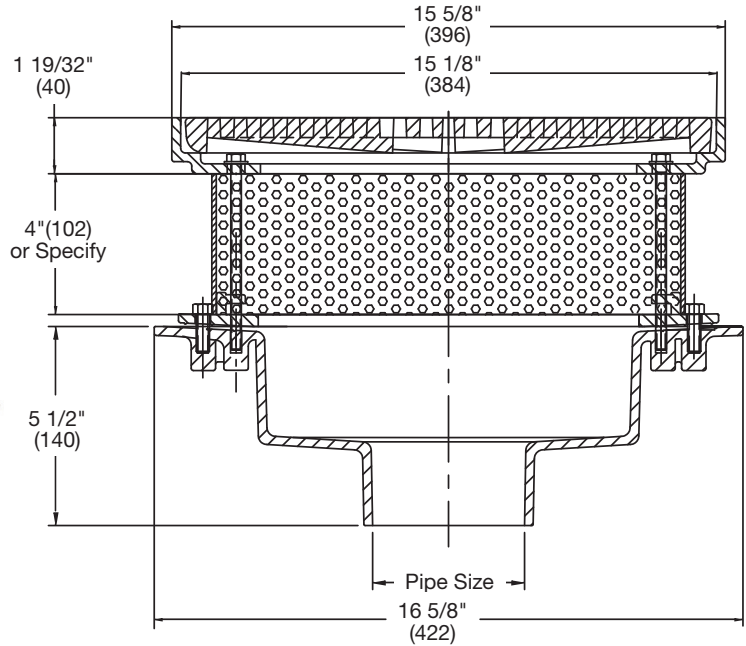

### NOTICE

The load classifications are in accordance with the American National Standards ASME A112.6.3 ASME Ratings are as follows:  
\*MD - Safe Live Load 5000-7499 lbs. (2268-3401 kg.)  
The above categories are given as a guide only. Please consult factory.

### NOTICE

The information contained herein is not intended to replace the full product installation and safety information available or the experience of a trained product installer. You are required to thoroughly read all installation instructions and product safety information before beginning the installation of this product.

Watts product specifications in U.S. customary units and metric are approximate and are provided for reference only. For precise measurements, please contact Watts Technical Service. Watts reserves the right to change or modify product design, construction, specifications, or materials without prior notice and without incurring any obligation to make such changes and modifications on Watts products previously or subsequently sold.



**USA:** T: (800) 338-2581 • F: (828) 248-3929 • Watts.com  
**Canada:** T: (888) 208-8927 • F: (905) 481-2316 • Watts.ca  
**Latin America:** T: (52) 55-4122-0138 • Watts.com



# Adjustable Accutrol Weir

Tag: \_\_\_\_\_

## Adjustable Flow Control for Roof Drains

### ADJUSTABLE ACCUTROL (for Large Sump Roof Drains only)

For more flexibility in controlling flow with heads deeper than 2", Watts Drainage offers the Adjustable Accutrol. The Adjustable Accutrol Weir is designed with a single parabolic opening that can be covered to restrict flow above 2" of head to less than 5 gpm per inch, up to 6" of head. To adjust the flow rate for depths over 2" of head, set the slot in the adjustable upper cone according to the flow rate required. Refer to Table 1 below.  
 Note: Flow rates are directly proportional to the amount of weir opening that is exposed.

#### EXAMPLE:

For example, if the adjustable upper cone is set to cover 1/2 of the weir opening, flow rates above 2" of head will be restricted to 2-1/2 gpm per inch of head.

Therefore, at 3" of head, the flow rate through the Accutrol Weir that has 1/2 the slot exposed will be:  
 [5 gpm (per inch of head) x 2 inches of head ] + 2-1/2 gpm (for the third inch of head) = 12-1/2 gpm.

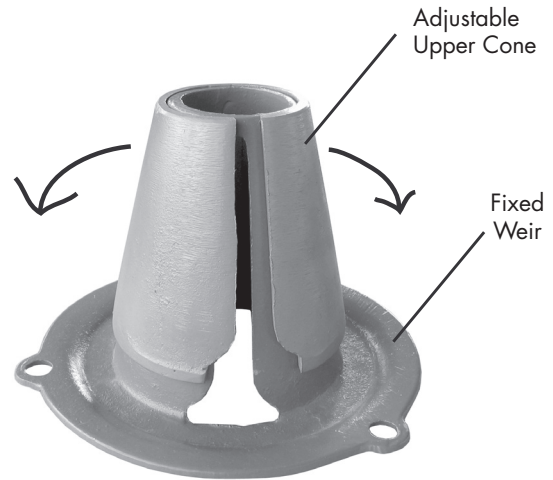
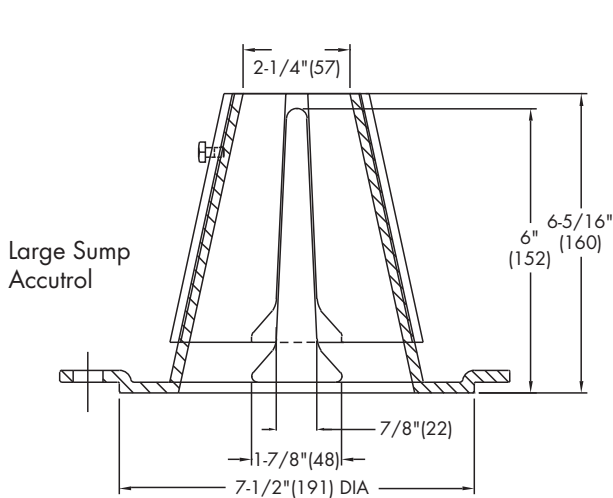

1/2 Weir Opening Exposed Shown Above

TABLE 1. Adjustable Accutrol Flow Rate Settings

Weir Opening Exposed	1"	2"	3"	4"	5"	6"
	Flow Rate (gallons per minute)					
Fully Exposed	5	10	15	20	25	30
3/4	5	10	13.75	17.5	21.25	25
1/2	5	10	12.5	15	17.5	20
1/4	5	10	11.25	12.5	13.75	15
Closed	5	5	5	5	5	5

Job Name \_\_\_\_\_  
 Job Location \_\_\_\_\_  
 Engineer \_\_\_\_\_

Contractor \_\_\_\_\_  
 Contractor's P.O. No. \_\_\_\_\_  
 Representative \_\_\_\_\_

Watts product specifications in U.S. customary units and metric are approximate and are provided for reference only. For precise measurements, please contact Watts Technical Service. Watts reserves the right to change or modify product design, construction, specifications, or materials without prior notice and without incurring any obligation to make such changes and modifications on Watts products previously or subsequently sold.

USA: Tel: (800) 338-2581 • Fax: (828) 248-3929 • Watts.com  
 Canada: Tel: (905) 332-4090 • Fax: (905) 332-7068 • Watts.ca  
 Latin America: Tel: (52) 81-1001-8600 • Fax: (52) 81-8000-7091 • Watts.com



### INFORMATION GÉNÉRALE

Application	Eau Pluviale	
Nom du projet	Kanata	
Numéro de projet		
Commentaire		
Identification		
Débit de conception (Q)	6	L/s
Charge d'eau de conception (h)	1	m
Diamètre de la conduite de sortie (C)	300	mm
Type de conduite	PVC	
Modèle	100 VHV-1,12,STD	
Item #	PRIPHY200283	
Quantité	1	
Dégagement minimum (H)	200	mm
Diamètre minimum du regard (B)	900	mm

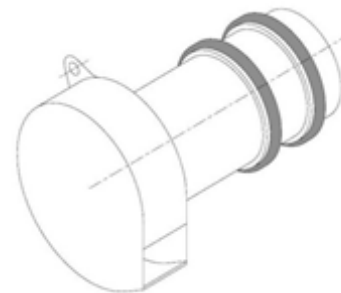

### COURBE DE DÉBIT

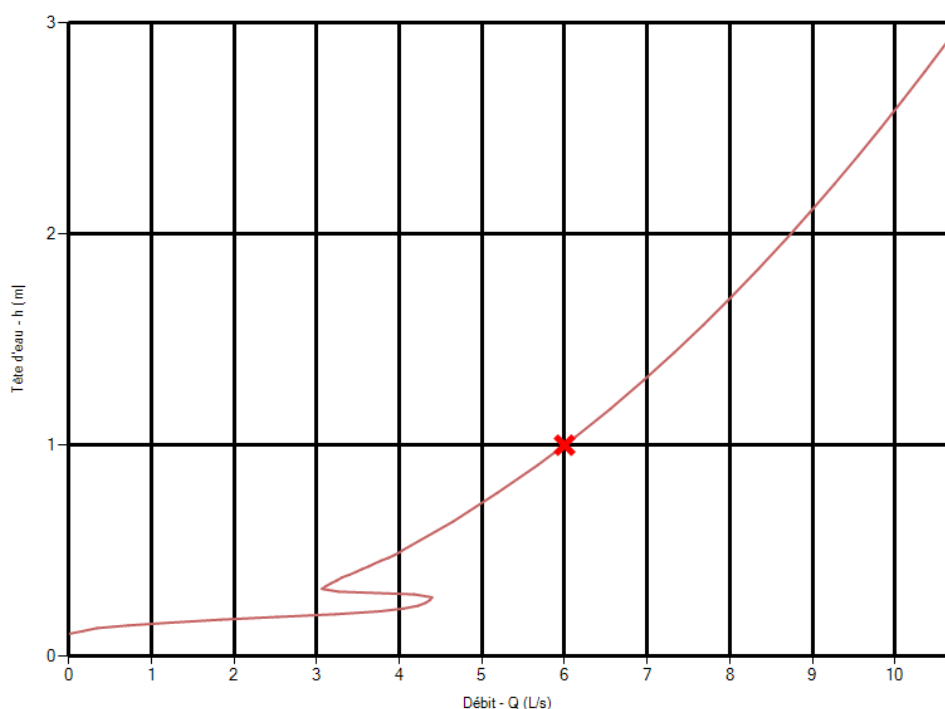

Q (L/s)	h (m)
0.000	0.106
1.835	0.173
4.227	0.239
3.262	0.306
3.305	0.373
3.700	0.439
4.056	0.506
6.554	1.172
8.354	1.839
9.830	2.505
11.112	3.172
12.261	3.838
17.947	8.104
23.170	13.436



### INSTALLATION TYPIQUE

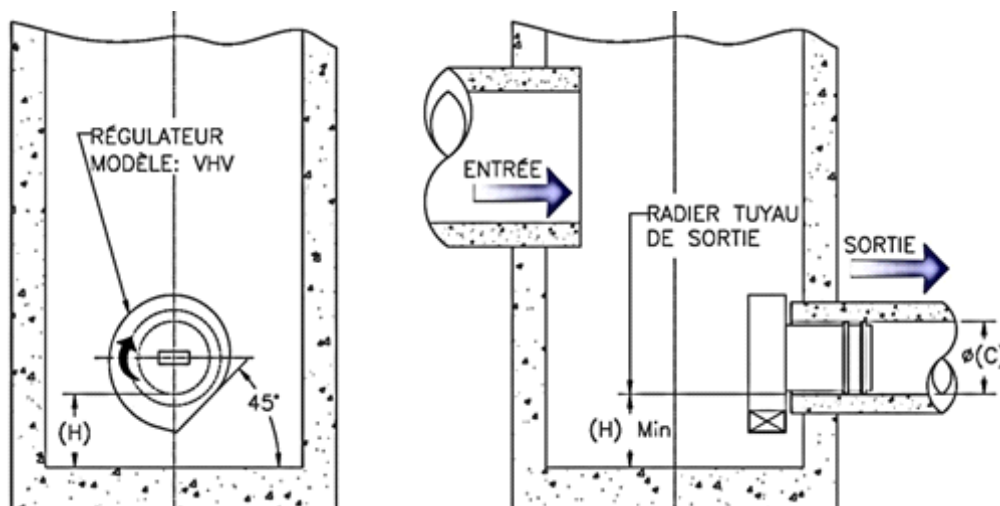

### SPÉCIFICATIONS

Le régulateur de débit sera du type statique utilisant le principe du vortex et n'aura aucune partie mobile. Le débit sera régularisé sur toute la charge en utilisant uniquement les propriétés hydrauliques de l'unité. Le régulateur sera auto activé et ne nécessitera pas d'instrumentation ou alimentation externe.

Chaque régulateur de débit est constitué d'un corps à l'intérieur duquel s'effectue le contrôle de débit. Un manchon est soudé au corps pour permettre son insertion convenable à l'intérieur du tuyau de sortie du regard. Deux joints toriques en caoutchouc assurent l'étanchéité et le maintien du manchon dans le tuyau. Deux barres soudées au manchon empêchent les joints toriques de se déplacer durant l'installation et le fonctionnement.

Le régulateur sera construit entièrement à partir d'acier inoxydable 304 avec soudures continues, tel que fabriqué par Veolia Water Technologies Canada Inc. (John Meunier), 514-334-7230, [cso@veolia.com](mailto:cso@veolia.com).



Nom du projet: Kanata  
 Numéro de projet:  
 Identification:  
 Débit (Q): 6 L/s  
 Charge d'eau (h): 1 m  
 Modèle: 100 VHV-1,12,STD  
 # item: PRIPHY200283  
 Quantité: 1

Dimensions (mm)	
A	100
B	82
L1	365
L2	328
L	200
DS	275
O1	38
O2	100
Ø ÉVENT	N/A

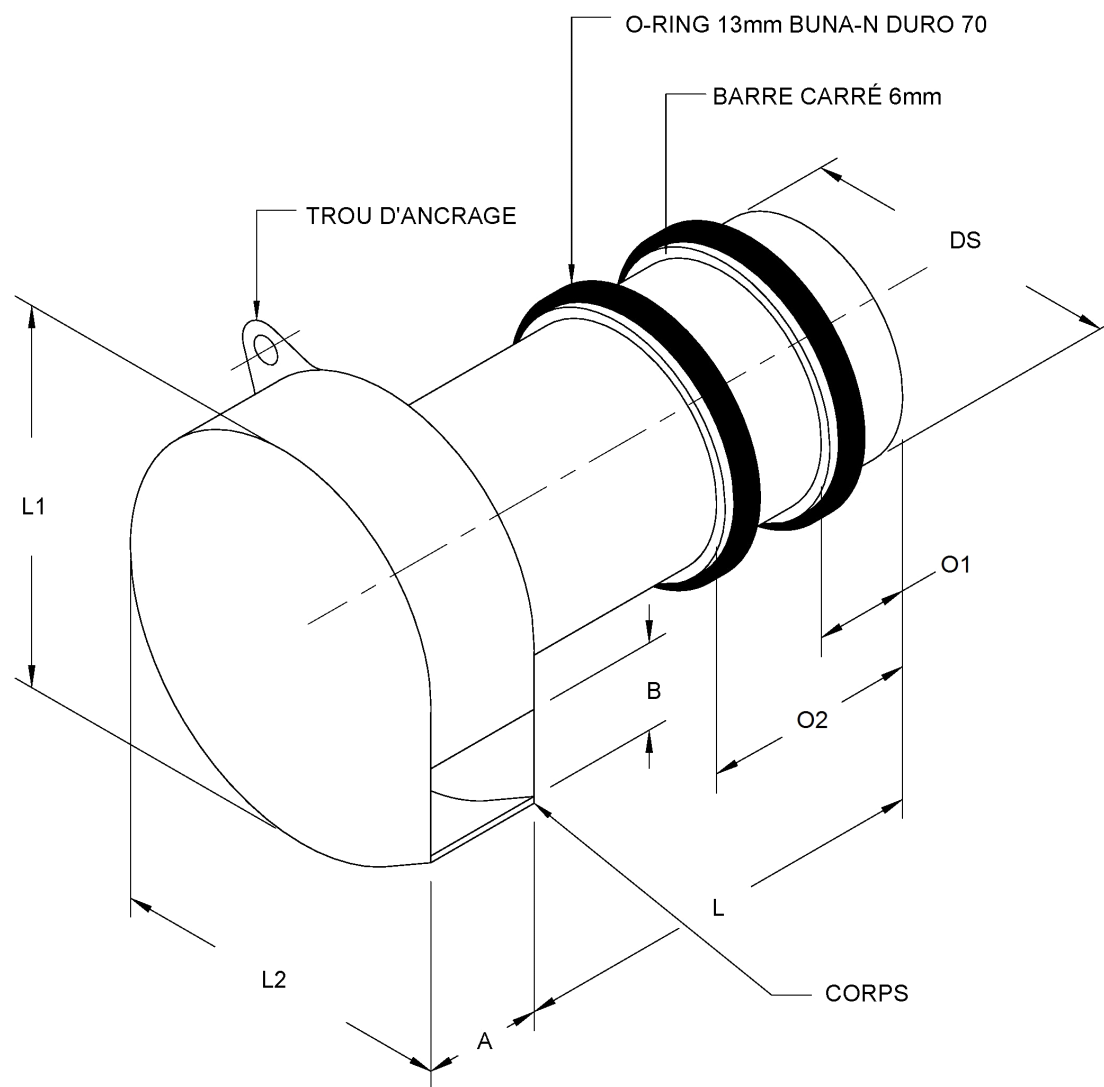

Toutes les dimensions sont en millimètres à moins avis du contraire