

Lisa Stern

LISA STERN
PLANNER
PLANNING, REAL ESTATE & ECONOMIC DEVELOPMENT
DEPARTMENT, CITY OF OTTAWA

APPROVED
By Lisa Stern at 12:22 pm, Dec 21, 2022

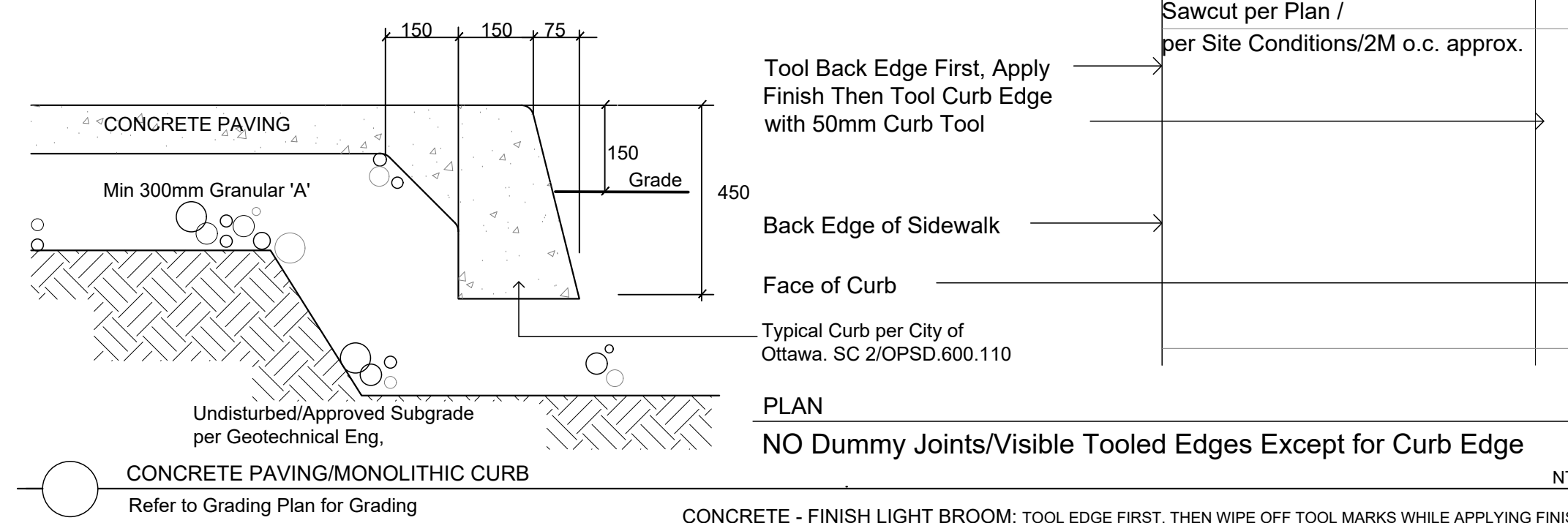

Tool Back Edge First, Apply Finish Then Tool Curb Edge with 50mm Curb Tool

Back Edge of Sidewalk

Face of Curb

Typical Curb per City of Ottawa. SC 2/OPS.D.600.110

PLAN
NO Dummy Joints/Visible Tool Edges Except for Curb Edge

CONCRETE - FINISH LIGHT BROOM: TOOL EDGE FIRST, THEN WIPE OFF TOOL MARKS WHILE APPLYING FINISH. EXPANSION JOINT/SAWCUT LAYOUT AND CONCRETE FINISHES TO BE APPROVED BY GJA LANDSCAPE ARCHITECT. PROVIDE COLD JOINT DETAIL at End of Previous Pour/Beginning of New Pour. C/W REBAR DOWELS 500mm O.C.

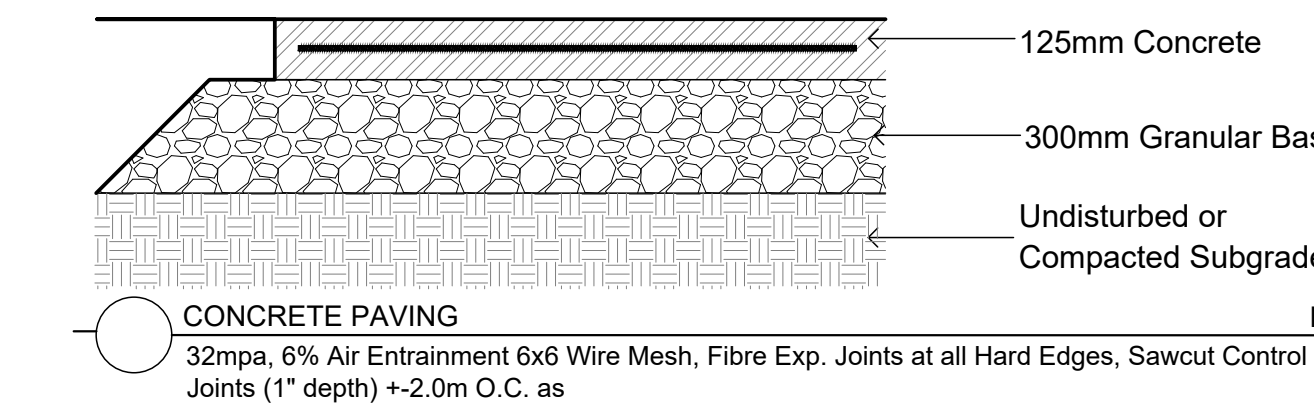

Code	Interim	To Complete	TOTAL	Botanical Name	Common Name	Size	Condition
AC	8	0	8	Amenlanchie canadensis	Serviceberry	1.5m Ht.	B + B MultiStem
AF	5	0	5	Acer x freemanii 'Autumn Blaze'	Autumn Blaze Freeman Maple	70mm cal	B + B specimen
AG	7	0	7	Aesculus glabra	Ohio Buckeye	60mm cal	B + B specimen
AR	3	0	3	Acer rubrum	Red Maple	70mm cal	B + B specimen
AS	3	0	3	Acer saccharum	Sugar Maple	60mm cal	B + B specimen
CD	3	0	3	Celtis occidentalis	Common Hackberry	60mm cal	B + B specimen
GD	3	0	3	Gymnocladus dioica	Kentucky Coffee Tree	60mm cal	B + B specimen
QM	3	8	11	Quercus macrocarpa	Bur Oak	70mm cal	B + B specimen
QR	3	0	3	Quercus rubra	Red Oak	60mm cal	B + B specimen
AB	1	0	1	Abies balsamea	Balsam Fir	2.0m Ht.	B + B specimen
LL	5	0	5	Larix laricina	Eastern Larch / Tamarack	2.25m Ht.	B + B specimen
PG	0	1	1	Picea glauca	White Spruce	1.5m Ht.	B + B specimen
PS	3	0	3	Pinus strobus	White Pine	1.75m Ht.	B + B specimen

Code	Interim	To Complete	TOTAL	Botanical Name	Common Name	Size	Condition
HK	335	165	500	Hypericum kalmianum	St. John's Wort	30cm Ht.	Pot
SA	110	40	150	Symphoricarpos albus	Snowberry	60cm Ht.	Pot
SA	150	0	150	Spiraea alba	Meadowsweet	60cm Ht.	Pot

Code	Interim	To Complete	TOTAL	Botanical Name	Common Name	Condition
	0	75	75	Geranium macrorrhizum	Bigroot Geranium	9cm Pot
	0	75	75	Geranium psilostemon 'Gerwat'	Rozanne Geranium	9cm Pot
	0	75	75	Panicum virgatum	Switch Grass	9cm Pot

Code	Interim	To Complete	TOTAL	Botanical Name	Common Name	Condition
	0	75	75	Geranium macrorrhizum	Bigroot Geranium	9cm Pot
	0	75	75	Geranium psilostemon 'Gerwat'	Rozanne Geranium	9cm Pot
	0	75	75	Panicum virgatum	Switch Grass	9cm Pot

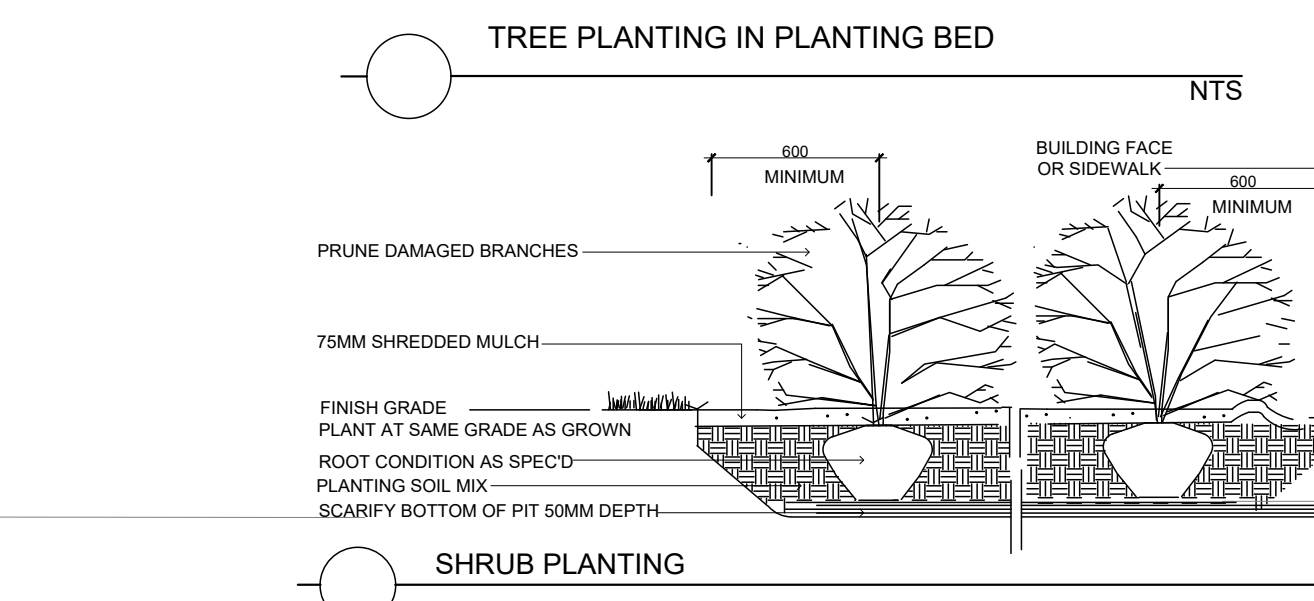
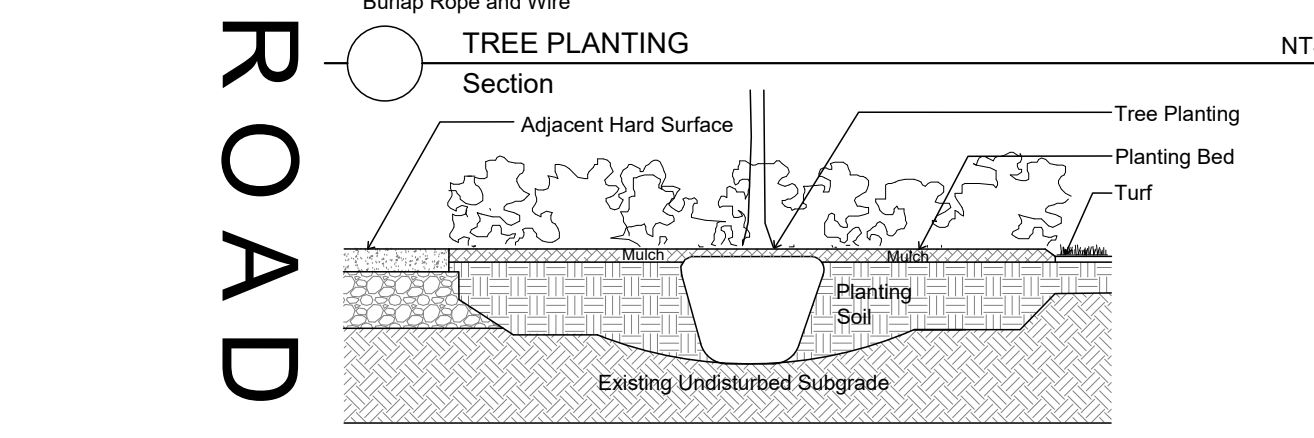
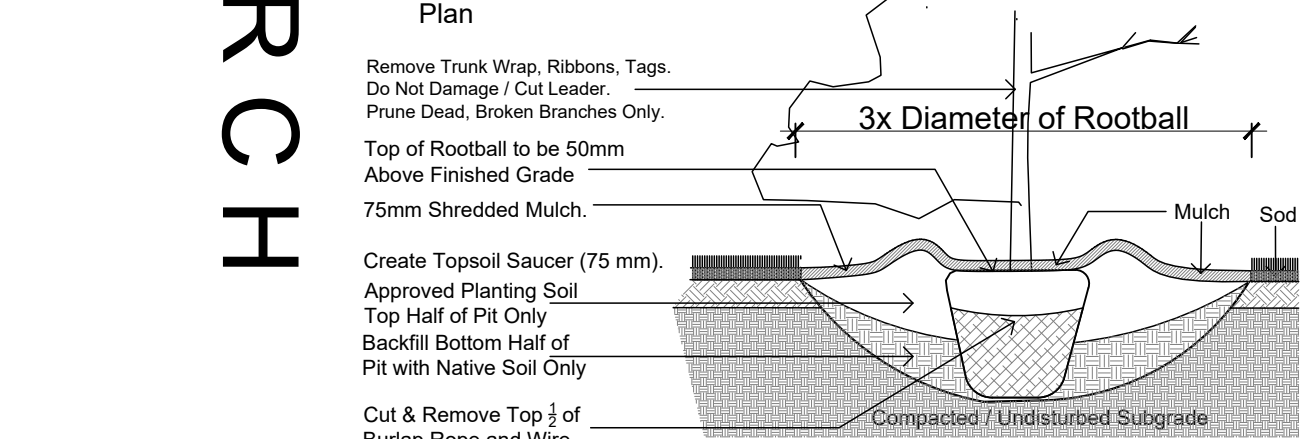
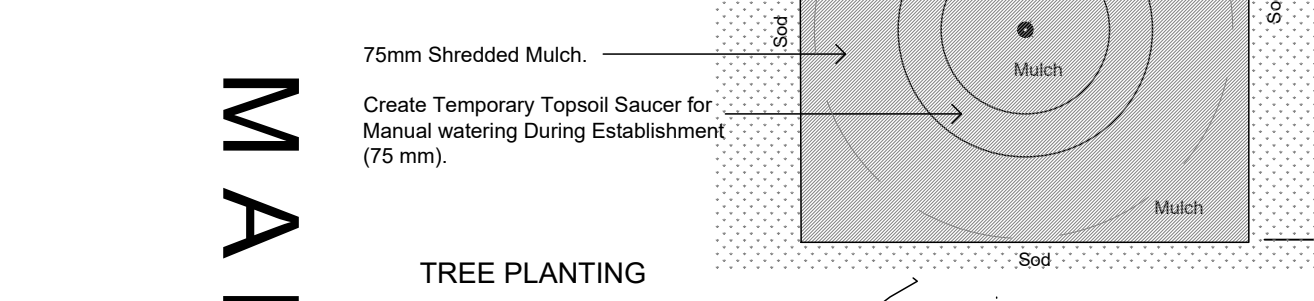
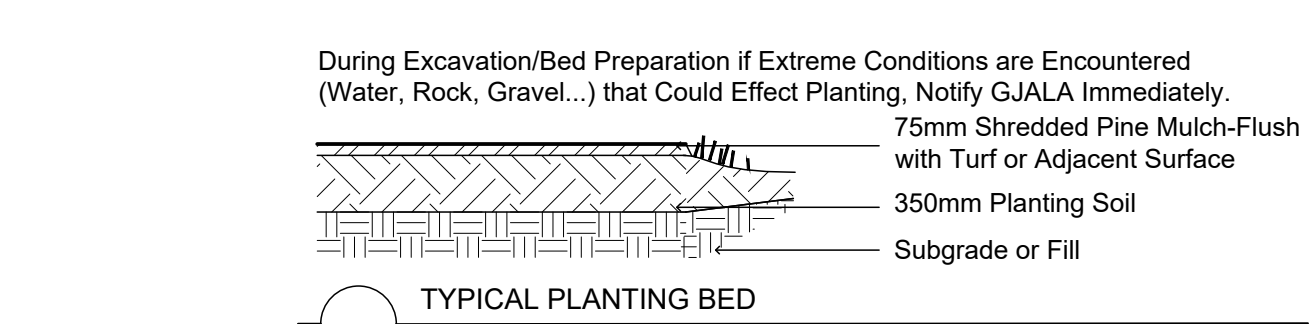

Drawing Remains the Property of/Copyright Reserved by Gino J. Aiello Landscape Architect. Do Not Use or Reproduce Without Approval of Gino J. Aiello. NOT To Be Used For Construction Unless indicated by Revision: "FOR LANDSCAPE CONSTRUCTION". Contractor is Responsible for Verification of Site Locations of all Utilities. Report any Discrepancies Between Site and Drawing Immediately to Gino J. Aiello. Do NOT Proceed Until Clarified.

TURF AREAS TO BE SOD C/W 150MM DEPTH TOPSOIL ON APPROVED SUBGRADE | SOD TO BE #1 GRADE TURFGRASS NURSERY SOD per NSGA - Fine Fescue/Kentucky Bluegrass Sod | PLANTING MIX TO BE APPROVED BY LANDSCAPE ARCHITECT | PLANT MATERIAL TO MEET CNLA STANDARDS/BE APPROVED BY LANDSCAPE ARCHITECT PRIOR TO PLANTING | ALL MATERIALS & WORK TO BE MAINTAINED UNTIL FINAL ACCEPTANCE. (MOWING TURF, WEEDING BEDS, WATERING TURF & PLANTS) & INCLUDE 1 YEAR WARRANTY FROM DATE OF FINAL ACCEPTANCE | PROVIDE WATERING OF ALL PLANT MATERIAL AS REQUIRED FOR PROPER ESTABLISHMENT, UNTIL END OF WARRANTY PERIOD | REFER TO CIVIL ENGINEER'S DRAWING FOR ELEVATIONS / GRADING |

The Landscape Plan is to be read in conjunction with the grading, servicing, site and survey plan | Bare root material to be planted in season only | All plant material locations to be staked on site by the landscape contractor and checked by the landscape architect prior to planting | All trees to be preserved on or directly adjacent to the site will be protected | Plant material are to be installed a minimum of, 3.0m away from any part of any hydro transformer, 3.0m corridor between a fire hydrant and the curb, a 2.5m radius beside or behind a fire hydrant, 2.0m from any servicing/utility line or structure |

LANDSCAPE PLAN LEGEND

Proposed Coniferous Tree

Proposed Deciduous Tree

Proposed Planting Bed

Proposed Concrete Pedestrian Pavement

Areas Labeled "Turf" To Be Topsoil and HydroSeed / TerraSeed - Native / Naturalize Seed Mix

Sod over 150mm Topsoil

BELOW GRADE SERVICES REFER TO CIVIL / CUP

U/G Water Service

U/G Storm Service

U/G Sanitary Service

Fire Hydrant

Light Standard Base

No.	Revision	Date
6	THIRD SUBMISSION SPC	DECEMBER 12 2022
5	99% DESIGN REVIEW	AUGUST 30 2022
4	SECOND SUBMISSION SPC	AUGUST 3 2022
3	60 %	JULY 26 2022
2	30 %	JUNE 17 2022
1	FIRST SUBMISSION SPC	MAY 20 2022
0	FOR PRICING / COORDINATION	DECEMBER 9 2021

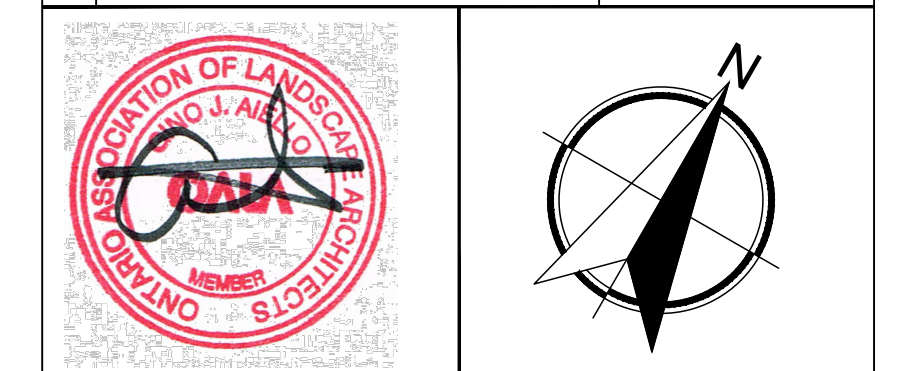

Ottawa

PLANNING AND INFRASTRUCTURE PORTFOLIO
INFRASTRUCTURE SERVICES DEPARTMENT
DESIGN AND CONSTRUCTION - BUILDINGS & PARKS BRANCH

PORTFOLIO DE L'URBANISME ET DE L'INFRASTRUCTURE
DÉPARTEMENT DES SERVICES D'INFRASTRUCTURE
DIRECTION DE CONCEPTION ET DE CONSTRUCTION - IMMEUBLES ET DES PARCS

Project **NEW FIRE STATION FS 45**
Buckbean Street @ March Road KANATA

Gino J. Aiello | landscape architect GJALA.com
GJA Inc. Gino@GJALA.com (613) 298-5100
110 Deberry Road Unit #1 (Ottawa, Ontario) K2T 0C2

Drawing **FINAL Landscape Plan**

Scale: 1:200 Sheet Number **L2**

City of Ottawa Dwg - 18766

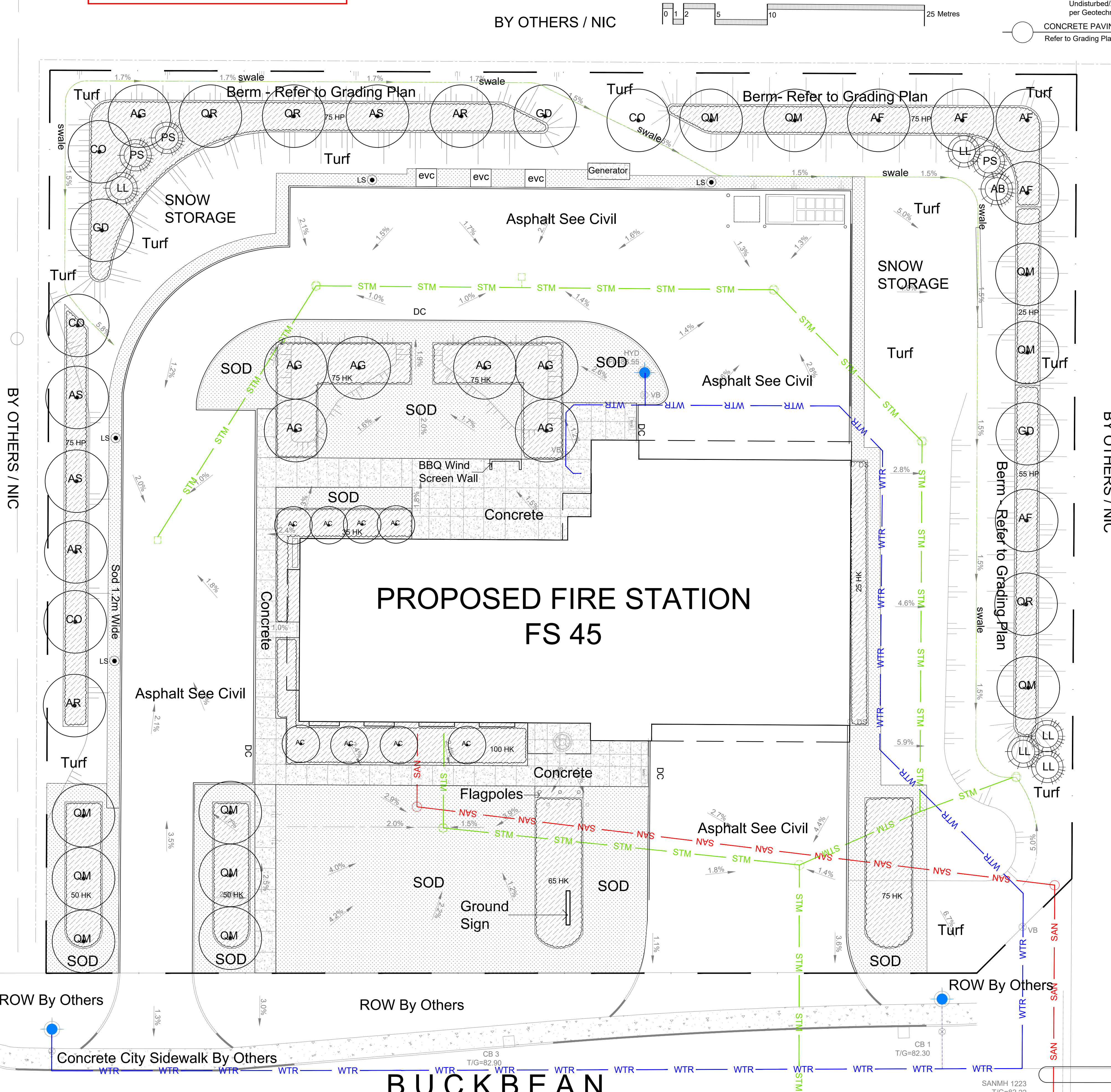

BY OTHERS / NIC

BY OTHERS / NIC

ROW By Others

ROW By Others

ROW By Others

Concrete City Sidewalk By Others

BUCKBEAN

SANMH 1223
T/G=82.22

MARCH ROAD

0600-12-22-0090
D07-12-22-0090

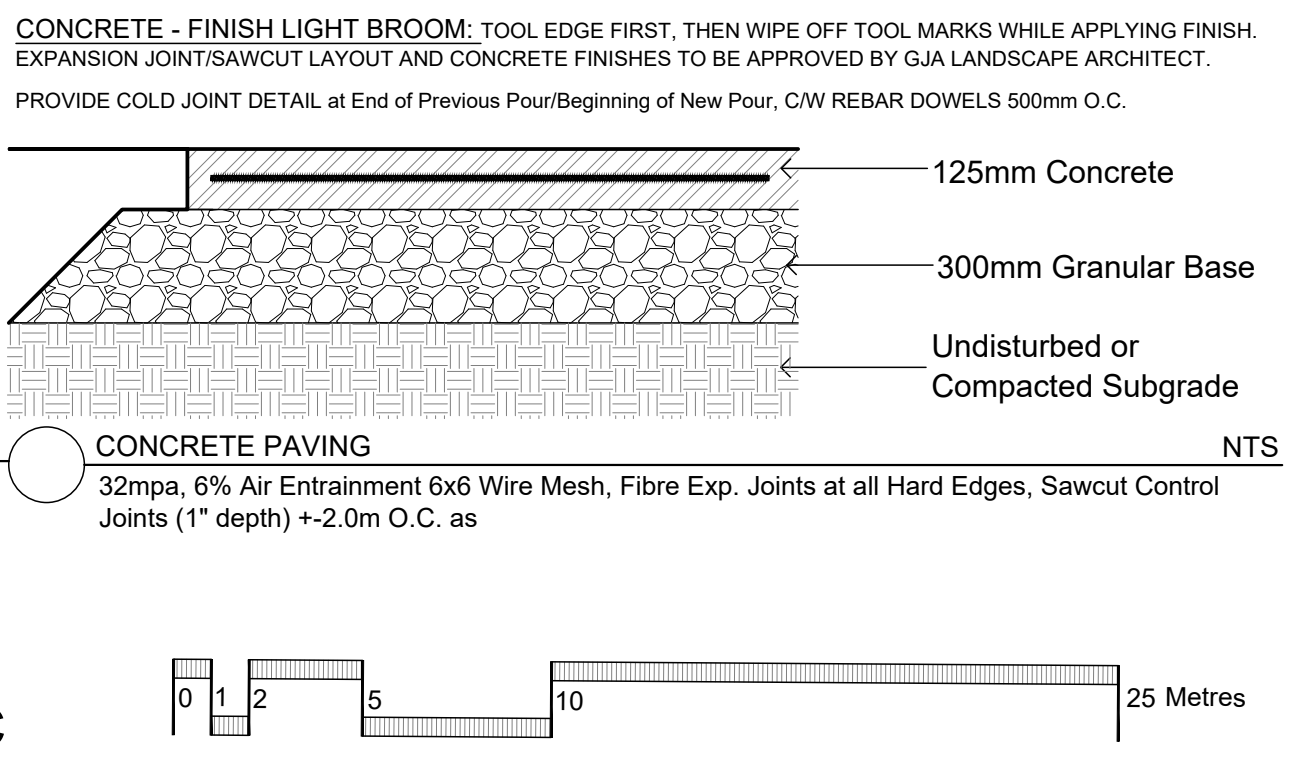
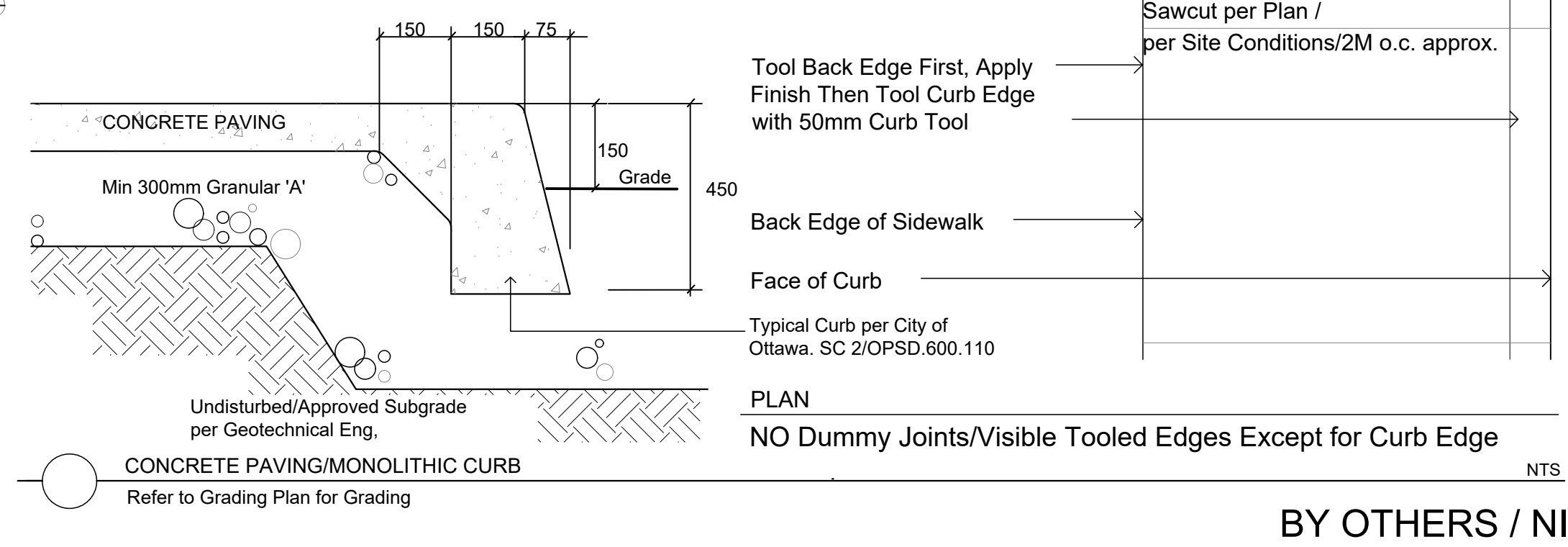

TREES FS45							
Code	Interim	To Complete	TOTAL	Botanical Name	Common Name	Size	Condition
AC	8	0	8	Amelanchier canadensis	Serviceberry	1.5m HT.	B + B MultiStem
AF	5	0	5	Acer fraxinifolium 'Autumn Blaze'	Autumn Blaze Freeman Maple	70mm cal	B + B specimen
AG	7	0	7	Aesculus glabra	Ohio Buckeye	60mm cal	B + B specimen
AR	3	0	3	Acer rubrum	Red Maple	70mm cal	B + B specimen
AS	3	0	3	Acer saccharum	Sugar Maple	60mm cal	B + B specimen
CO	3	0	3	Celtis occidentalis	Common Hackberry	60mm cal	B + B specimen
GD	3	0	3	Gymnocladus dioica	Kentucky Coffee Tree	60mm cal	B + B specimen
QM	3	8	11	Quercus macrocarpa	Bur Oak	70mm cal	B + B specimen
QR	3	0	3	Quercus rubra	Red Oak	60mm cal	B + B specimen
AB	1	0	1	Abies balsamea	Balsam Fir	2.0m HT.	B + B specimen
LL	5	0	5	Larix laricina	Eastern Larch / Tamarack	2.25m HT.	B + B specimen
PG	0	1	1	Picea glauca	White Spruce	2.5m HT.	B + B specimen
PS	3	0	3	Pinus strobus	White Pine	1.75m HT.	B + B specimen

SHRUBS FS45							
Code	Interim	To Complete	TOTAL	Botanical Name	Common Name	Size	Condition
HK	335	165	500	Hypericum kalmianum	St. John's Wort	30cm HT.	Pot
SA	110	40	150	Symphoricarpos albus	Snowberry	60cm HT.	Pot
SA	150	0	150	Spiraea alba	Meadowsweet	50cm HT.	Pot

GC FS45						
Code	Interim	To Complete	TOTAL	Botanical Name	Common Name	Condition
	0	75	75	Geranium kalmianum	Bigroot Geranium	9cm Pot
	0	75	75	Geranium psilostemon 'Gervat'	Rozanne Geranium	9cm Pot
	0	75	75	Panicum virgatum	Switch Grass	9cm Pot

Drawing Remains the Property of/Copyright Reserved by Gino J. Aiello Landscape Architect. Do Not Use or Reproduce Without Approval of Gino J. Aiello.

NOT To Be Used For Construction Unless indicated by Revision: **"FOR LANDSCAPE CONSTRUCTION"**.

Contractor is Responsible for Verification of Site Locations of all Utilities. Report any Discrepancies Between Site and Drawing Immediately to Gino J. Aiello. Do NOT Proceed Until Clarified.

SOD TO BE #1 GRADE TURFGRASS NURSERY SOD per NSGA - Fine Fescue/Kentucky Bluegrass Sod | PLANTING MIX TO BE APPROVED BY LANDSCAPE ARCHITECT | PLANT MATERIAL TO MEET CNLA STANDARDS/BE APPROVED BY LANDSCAPE ARCHITECT PRIOR TO PLANTING | ALL MATERIALS & WORK TO BE MAINTAINED UNTIL FINAL ACCEPTANCE (MOWING TURF, WEEDING BEDS, WATERING TURF & PLANTS) & INCLUDE 1 YEAR WARRANTY FROM DATE OF FINAL ACCEPTANCE | PROVIDE WATERING OF ALL PLANT MATERIAL AS REQUIRED FOR PROPER ESTABLISHMENT, UNTIL END OF WARRANTY PERIOD | REFER TO CIVIL ENGINEER'S DRAWING FOR ELEVATIONS / GRADING

The Landscape Plan is to be read in conjunction with the grading, servicing, site and survey plan | Bare root material to be planted in season only | All plant material locations to be staked on site by the landscape contractor and checked by the landscape architect prior to planting | All trees to be preserved on or directly adjacent to the site will be protected | Plant material are to be installed a minimum of: 3.0m away from any part of any hydro transformer, 3.0m corridor between a fire hydrant and the curb, a 2.5m radius beside or behind a fire hydrant, 2.0m from any servicing/utility line or structure |

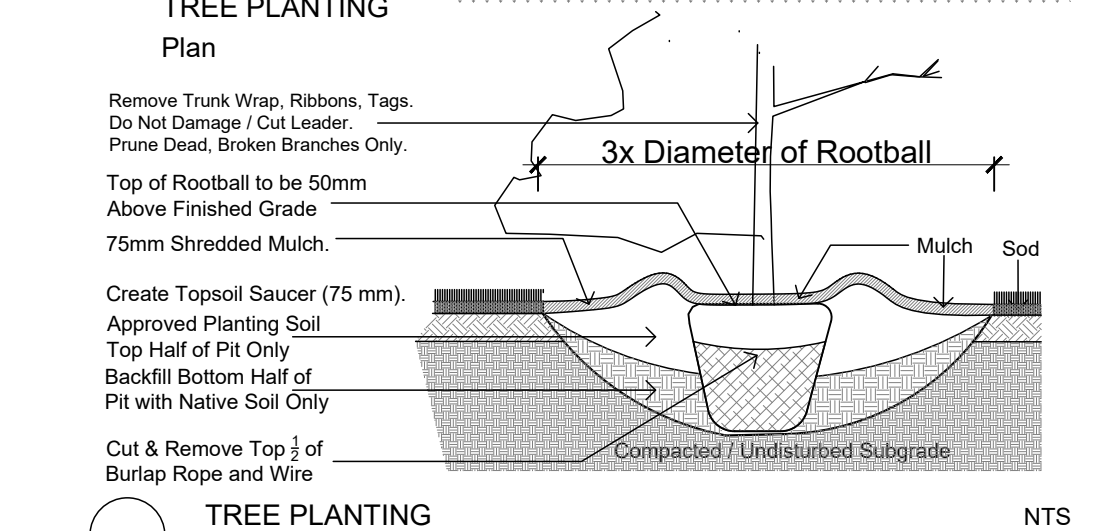
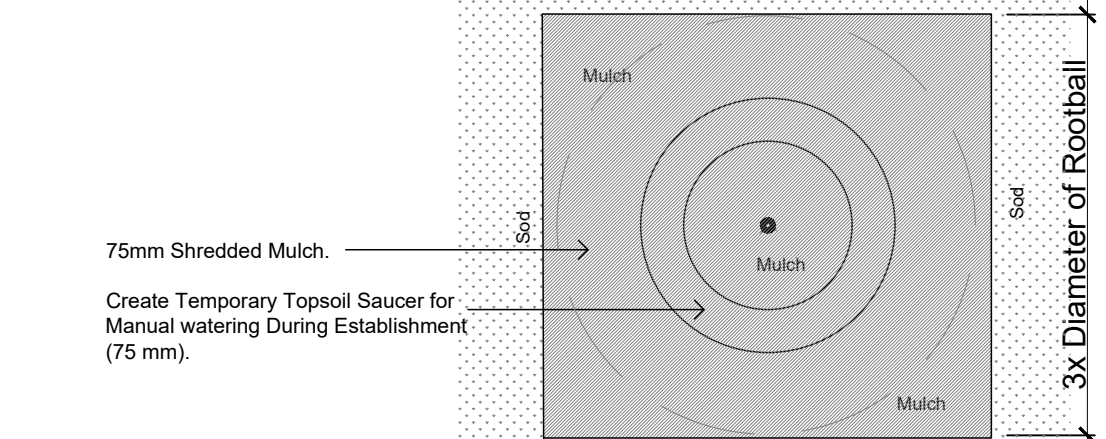
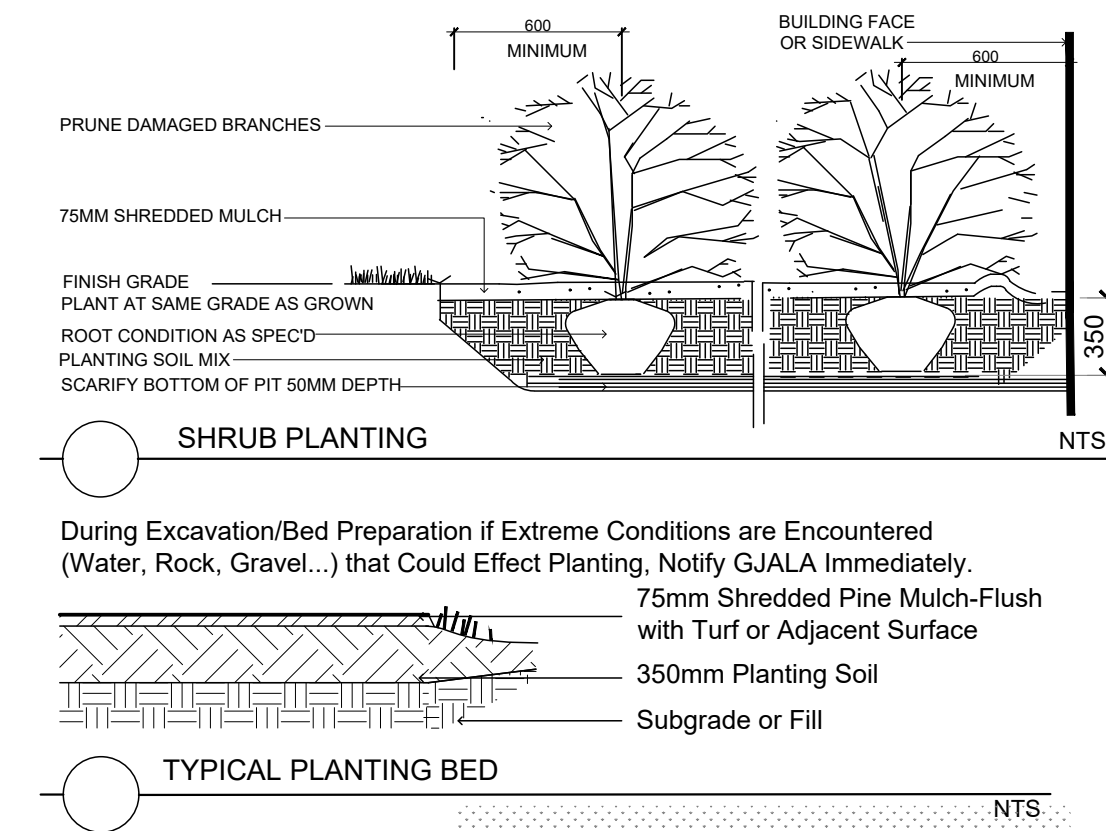
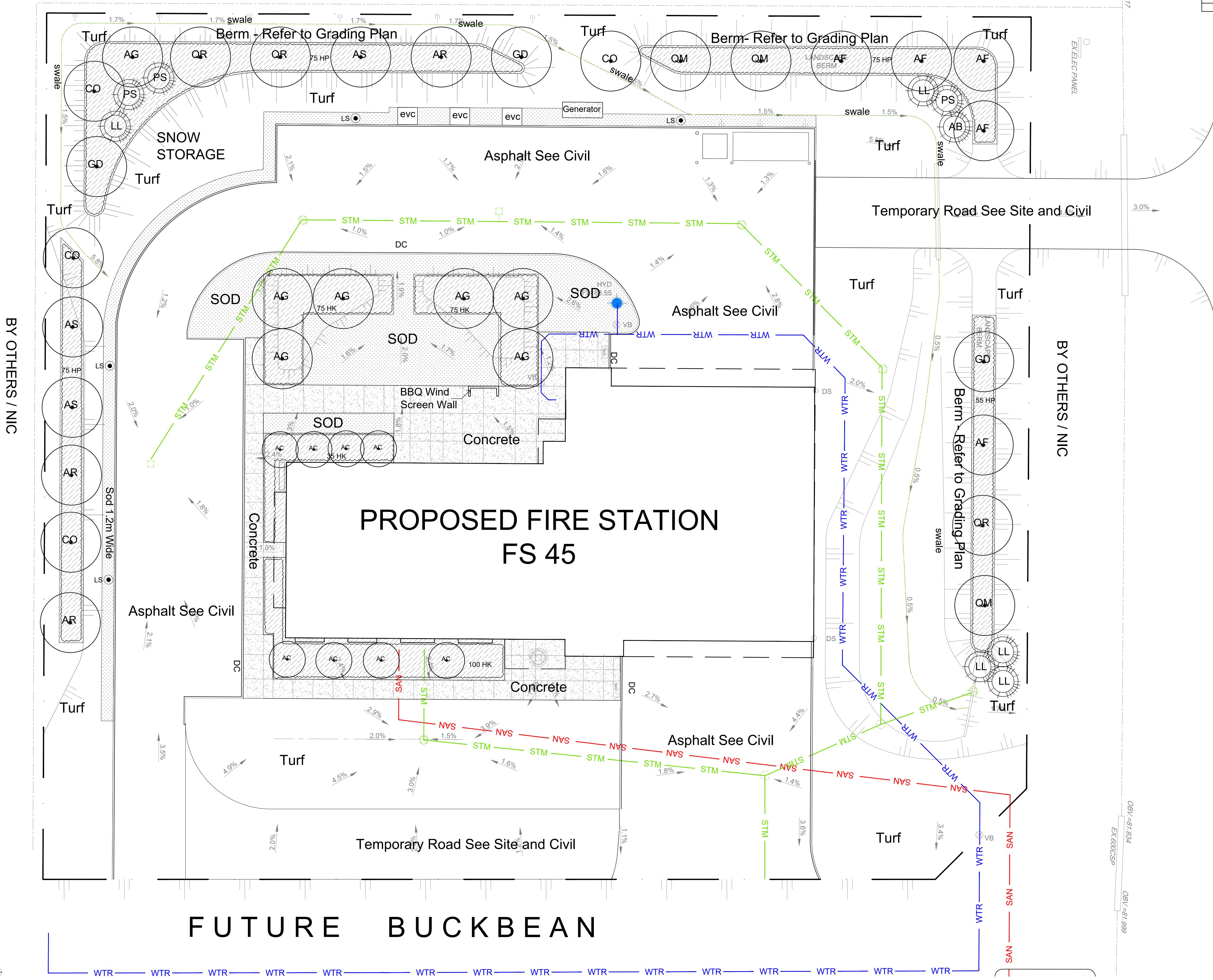

- LANDSCAPE PLAN LEGEND**
- Proposed Coniferous Tree
 - Proposed Deciduous Tree
 - Proposed Planting Bed
 - Proposed Concrete Pedestrian Pavement
 - Areas Labeled "Turf" To Be Topsoil and HydroSeed / TerraSeed - Native / Naturalize Seed Mix
 - Sod over 150mm Topsoil
 - BELOW GRADE SERVICES REFER TO CIVIL / CUP
 - WTR U/G Water Service
 - STM U/G Storm Service
 - SAN U/G Sanitary Service
 - Fire Hydrant
 - Light Standard Base

No.	Revision	Date
6	INTERIM PLAN FOR SPC	DECEMBER 12 2022
5	99% DESIGN REVIEW	AUGUST 30 2022
4	SECOND SUBMISSION SPC	AUGUST 3 2022
3	60 %	JULY 26 2022
2	30 %	JUNE 17 2022
1	FIRST SUBMISSION SPC	MAY 20 2022
0	FOR PRICING / COORDINATION	DECEMBER 9 2021

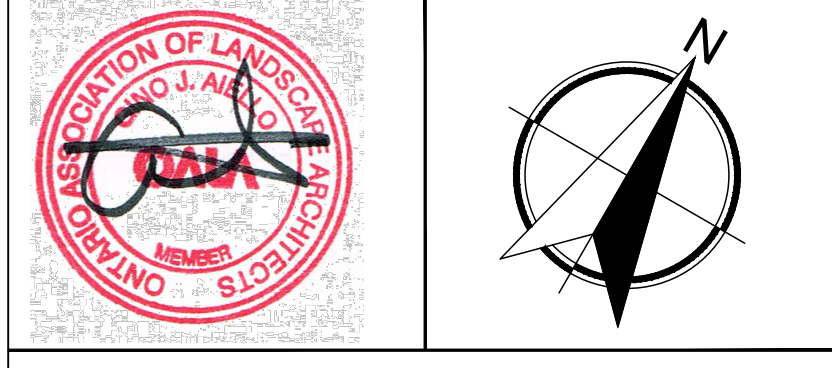

NEW FIRE STATION FS 45
Buckbean Street @ March Road KANATA

Gino J. Aiello | landscape architect GJALA.com
GJA Inc. Gino@GJALA.com (613) 288 5100
110 Debarry Road Unit #1 (Ottawa Ontario) K2T 0C2

INTERIM Landscape Plan

Scale: 1:200 Sheet Number
City of Ottawa Dwg - 18766 **L1**

D07-12-22-0090

Lisa Stern

LISA STERN
PLANNER
PLANNING, REAL ESTATE & ECONOMIC DEVELOPMENT
DEPARTMENT, CITY OF OTTAWA

APPROVED
By Lisa Stern at 12:23 pm, Dec 21, 2022

MARCH ROAD