

ACCESS PROPERTY DEVELOPMENTS

NOISE IMPACT ASSESSMENT 864 LADY ELLEN PLACE, OTTAWA

DECEMBER 20, 2022

FINAL

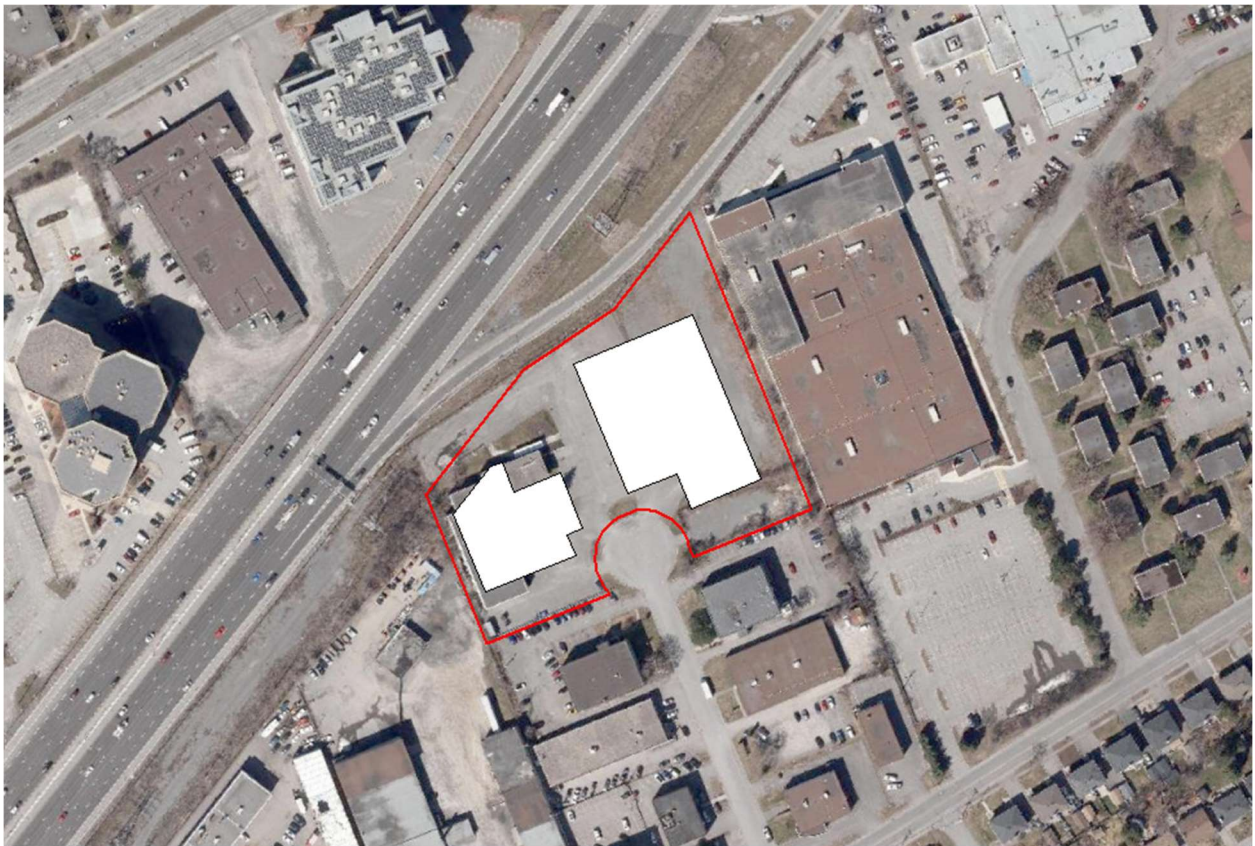



NOISE IMPACT ASSESSMENT

864 LADY ELLEN PLACE,
OTTAWA

ACCESS PROPERTY DEVELOPMENTS

FINAL

PROJECT NO.: 221-04646-00
DATE: DECEMBER 20, 2022

WSP
UNIT 2
126 DON HILLOCK DRIVE
AURORA, ON, CANADA L4G 0G9

T: +1 905 750-3080
F: +1 905 727-0463
WSP.COM

VERSION HISTORY

FIRST ISSUE	DATE	TITLE	COMMENTS	PREPARED BY
1.0	December 20, 2022	Noise Impact Assessment	For Site Plan Control Application	WSP Canada Inc.

SIGNATURES

PREPARED BY



Carolyn Ropp, BSc.
Acoustics, Noise & Vibration Specialist

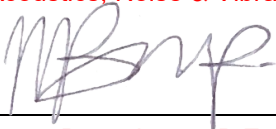

Megan Beauchamp, B.Eng., EIT
Acoustics, Noise & Vibration Specialist

REVIEWED BY

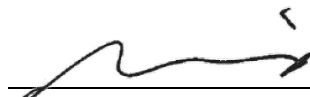

Cris delos Santos, M.Eng., P.Eng.
Senior Engineer, Acoustics, Noise & vibration



LIMITATIONS

WSP Canada Inc. (“WSP”) prepared this report solely for the use of the intended recipient, ACCESS PROPERTY DEVELOPMENTS, in accordance with the professional services agreement between the parties. In the event a contract has not been executed, the parties agree that the WSP General Terms for Consultant shall govern their business relationship which was provided to you prior to the preparation of this report.

The report is intended to be used in its entirety. No excerpts may be taken to be representative of the findings in the assessment.

The conclusions presented in this report are based on work performed by trained, professional and technical staff, in accordance with their reasonable interpretation of current and accepted engineering and scientific practices at the time the work was performed.

The content and opinions contained in the present report are based on the observations and/or information available to WSP at the time of preparation, using investigation techniques and engineering analysis methods consistent with those ordinarily exercised by WSP and other engineering/scientific practitioners working under similar conditions, and subject to the same time, financial and physical constraints applicable to this project.

WSP disclaims any obligation to update this report if, after the date of this report, any conditions appear to differ significantly from those presented in this report; however, WSP reserves the right to amend or supplement this report based on additional information, documentation or evidence.

WSP makes no other representations whatsoever concerning the legal significance of its findings.

The intended recipient is solely responsible for the disclosure of any information contained in this report. If a third party makes use of, relies on, or makes decisions in accordance with this report, said third party is solely responsible for such use, reliance or decisions. WSP does not accept responsibility for damages, if any, suffered by any third party as a result of decisions made or actions taken by said third party based on this report.

WSP has provided services to the intended recipient in accordance with the professional services agreement between the parties and in a manner consistent with that degree of care, skill and diligence normally provided by members of the same profession performing the same or comparable services in respect of projects of a similar nature in similar circumstances. It is understood and agreed by WSP and the recipient of this report that WSP provides no warranty, express or implied, of any kind. Without limiting the generality of the foregoing, it is agreed and understood by WSP and the recipient of this report that WSP makes no representation or warranty whatsoever as to the sufficiency of its scope of work for the purpose sought by the recipient of this report.

In preparing this report, WSP has relied in good faith on information provided by others, as noted in the report. WSP has reasonably assumed that the information provided is correct and WSP is not responsible for the accuracy or completeness of such information.

Benchmark and elevations used in this report are primarily to establish relative elevation differences between the specific testing and/or sampling locations and should not be used for other purposes, such as grading, excavating, construction, planning, development, etc.

The original of this digital file will be kept by WSP for a period of not less than 10 years. As the digital file transmitted to the intended recipient is no longer under the control of WSP, its integrity cannot be assured. As such, WSP does not guarantee any modifications made to this digital file subsequent to its transmission to the intended recipient.

This limitations statement is considered an integral part of this report.



TABLE OF CONTENTS

1	INTRODUCTION	1
1.1	The Site and Surrounding Area	1
1.2	The Proposed Development.....	1
2	STATIONARY NOISE SOURCES.....	2
2.1	Rooftop Mechanical Equipment.....	2
2.2	Vehicle Activities	2
2.3	Loading and/or Unloading Activities.....	2
3	POINTS OF RECEPTION	3
4	NOISE GUIDELINES AND ASSESSMENT CRITERIA	4
4.1	Sound Level Descriptor	4
4.2	Sound Level Limits	4
4.2.1	Steady-State (Non-Impulsive)	4
4.2.2	Impulsive Sources.....	5
5	NOISE IMPACT ASSESSMENT	6
5.1	Analysis Method	6
5.2	Predictable Worst-Case	6
5.3	Operating Scenarios	6
5.4	Results.....	7
5.4.1	Steady-State (non-Impulsive) Sound	7
5.4.2	Impulsive Sound.....	8
6	CONCLUSIONS	10

TABLES

TABLE 3-1	SUMMARY OF NOISE RECEPTORS	3
TABLE 4-1	MECP NOISE CRITERIA EXCLUSION LIMITS IN DBA (STEADY-STATE SOURCES)	5
TABLE 4-2	MECP EXCLUSION LIMITS IN DBAI (IMPULSIVE SOURCES)	5
TABLE 5-1	OPERATING SCENARIOS	7
TABLE 5-1	PREDICTED SOUND LEVELS FROM STATIONARY SOURCES	8

FIGURES

FIGURE 1:	SITE LOCATION	
FIGURE 2:	LAND USE ZONING DESIGNATION	
FIGURE 3:	SOURCE ID AND RECEPTORS LOCATIONS	
FIGURE 4:	STEADY-STATE SOUND LEVEL CONTOUR AT 4.5 M – DAYTIME AND EVENING	
FIGURE 5:	STEADY-STATE SOUND LEVEL CONTOUR AT 4.5 M – NIGHTTIME	
FIGURE 6:	IMPULSE SOUND LEVEL CONTOUR AT 4.5 M – DAYTIME AND EVENING (BUILDING A SOUTH)	

APPENDICES

APPENDIX A	DRAWINGS	
APPENDIX B	SUPPORTING DOCUMENTS	
APPENDIX C	SAMPLE CALCULATIONS	

1 INTRODUCTION

WSP Canada Inc. (WSP) was retained by Access Property Developments to prepare a Noise Impact Study for the proposed commercial development to be located at 864 Lady Ellen Place in Ottawa, Ontario (the Site).

The purpose of this study is to evaluate the potential noise impacts of stationary sources associated with the Site to the neighbouring noise sensitive receptors. The report was prepared in support of a Site Plan Control Application (SPCA) submission to the City of Ottawa (the City).

The noise impact assessment was conducted in accordance with the City's *Environmental Noise Control Guidelines* (ENCG) and the Ministry of Environment, Conservation and Parks (MECP) Noise Pollution Control (NPC) publication NPC-300 "*Environmental Noise Guideline, Stationary and Transportation Sources –Approval and Planning*". This report was based on the Proposed Site Plan provided by Architecture 49, dated November 29, 2022. The Proposed Site Plan is included as **Appendix A**.

1.1 THE SITE AND SURROUNDING AREA

The Site is located in the Carlington neighbourhood area in Ottawa, Ontario at 864 Lady Ellen Place, between Carling and Maitland next to the 417 Highway. The Site is bounded by:

- **South:** several industrial and commercial buildings and then residential buildings on the other side of Laperriere Avenue.
- **East:** single-storey commercial and office building at 1550 Carling Avenue and surface parking areas with residential dwellings further east.
- **West:** Single-storey warehouse buildings, surface parking lots, outdoor storage.
- **North:** Highway 417 and further north other industrial and commercial facilities.

The location of the Site is shown in **Figure 1**. A zoning map showing the land use surrounding the proposed development from the City of Ottawa is provided in **Figure 2**. The Site is currently zoned "Light Industrial, Urban Exception 278, Height Limit 30" (IL [278] H(30)) under the City of Ottawa Zoning By-Law 2008-250. The area surrounding the proposed development includes Parks and Open Space, Arterial Mainstreet Zone, and Light Industrial Zone.

1.2 THE PROPOSED DEVELOPMENT

Access Property Developments intends to develop two (2) self-storage/warehouse buildings. The first of these will be a four-storey light industrial building with a gross floor area (GFA) of 15,913 m², containing self-storage units on the upper three (3) storeys and warehouse space on the ground floor with loading bays. The ground floor will also contain ancillary administrative office space to serve clients of the self-storage use. The second building will consist of a single-storey self-storage building with a GFA of 1,750 m². There will also be surface parking around the buildings. The buildings will be separated by a central driveway which extends out to Lady Ellen Place. Two new access roads to the left and right will provide vehicular access to the site from the cul-de-sac at the end of Lady Ellen Place.

The proposed hours of the warehouse or rental office is 9 am to 5 pm, Monday to Friday. However, the self-storage will be accessible 24 hours a day 7 days a week via secure access.

The locations of the proposed structures, parking and access associated with the site layout are illustrated in preliminary design drawing of the proposed development is included in **Appendix A**.

2 STATIONARY NOISE SOURCES

Stationary source is defined in the ENCG and the MECP publication NPC-300 as source of sound or combination of sources of sound that are included and normally operated within the property lines of a facility.

The noise sources considered in the assessment are rooftop HVAC units and noise associated with vehicle movements within the Site. The noise stationary source locations are shown in **Figure 3**. The overall sound power levels and source heights are listed in **Appendix B**.

As the project is still in its early stages, detailed mechanical design and final equipment selection are not yet available. Thus, typical assumptions based on similarly sized facilities have been used to assess its potential noise impact to the surrounding noise sensitive land use.

2.1 ROOFTOP MECHANICAL EQUIPMENT

As the mechanical information is not available at this time, the size of the rooftop HVAC units was estimated based on building size. Building A (15,913m²), the four-storey self-storage, assumed to have twelve (12) 10-ton HVAC units. For the one-storey self-storage Building B (1,750m²), it was assumed to have three (3) 10-ton HVAC units.

The HVAC units were assumed to operate continually for full hour during the daytime, evening, and nighttime (100% duty cycle) to be conservative.

2.2 VEHICLE ACTIVITIES

Vehicle trips on the proposed site was supplied in a memo relating to the Traffic Impact Study provided by WSP, dated December 2, 2022 (included in **Appendix B**). For the proposed self-storage land use, the anticipated number of trips during AM and PM peak hours are expected to be 17 and 29, respectively.

As the proposed development's hours of operation is during the daytime hours only, the busiest 1-hour period (predictable worst-case), based on the memo provided for each building is expected to have the following volumes: Building A – 15 trucks per hour; and Building B – 14 trucks per hour for a total of 29 trucks per hour on site.

It is understood that there will be no refrigerated trucks entering and leaving the facility. Typical trucks used for warehousing activities are tractor semi-trailer trucks and or/ 26-foot delivery trucks and thus were assumed to be heavy duty trucks in this assessment as a conservative approach. All trucks are assumed to travel at 15 kph while within the site. Reference emission levels for trucks were taken from WSP database.

Truck movements were modelled as a moving point source (line source). Heavy trucks travelling at 15 kph were modelled using a reference sound power level of 102 dBA at 2.4 m above grade.

Trucks are not expected to idle on site. However, five minutes of idling per loading area was included in the assessment to account for any accidental idling that may occur during arrival or departure.

2.3 LOADING AND/OR UNLOADING ACTIVITIES

To be conservative, more than 9 forklift entry and exits are assumed to occur within an hour at the Site. A sound power level of 99.7 dBA (based on previous WSP measurements) were used to model this activity occurring at loading areas of Building A and B. As per provided Site Plan provided in Appendix A, Building A has two (2) loading docks at the northwest and southeast corners and Building B has one (1) at the northeast corner.

3 POINTS OF RECEPTION

Points of reception (PORs) for a noise assessment are those locations identified to be noise sensitive. The site-attributable sound level is the logarithmic sum of the individual noise source contributions at each POR. In accordance with Publication NPC-300, a POR is a property that accommodates a dwelling, a noise-sensitive commercial building, or a noise-sensitive institutional building. Noise-sensitive land uses may also constitute one or more PORs. PORs for an acoustic assessment are those locations where the sound from the Site is received and assessed against applicable limits. Sound may be assessed at the outdoor areas (outdoor point of reception, OPOR) and/or at a plane of a window (PW) of a noise sensitive window.

OPORs associated with residential dwellings or noise-sensitive land uses require assessment. For dwellings, the OPORs are on the land use defined as the lesser of 30 m from the facade of the building or the property line, at a height of 1.5 m above ground, typically in backyards, front yards, or patios. PWs at the facade of a building include windows or openings in the facade leading to noise-sensitive spaces such as bedrooms, living rooms, classrooms, treatment rooms, or assembly spaces for worship.

The objective of this assessment is to determine the predictable worst-case one-hour equivalent sound level (Leq, dBA) at the worst-case PORs. The worst-case POR is defined as the noise-sensitive receptor with the greatest potential exposure to the noise sources due to proximity and line-of-sight.

A total of nine (9) receptors were chosen to represent the potentially impacted points of reception in this area. The receptor heights for PORs have been either assessed at 4.5 m for two-storey dwelling structures representing the second-floor window, or at 5.5 m for the apartments which are a split level and three-storey apartments with the bottom level some of it being below grade.

There are noise sensitive land uses to the north and northwest of the Site. However, these receptors are sufficiently separated from the Site with Highway 417 intervening in between. These receptors are expected to experience elevated background noise levels due to road traffic from the highway. Thus, significant noise impact due to the operation of the Site is not expected at these receptors and therefore, have not been considered further in the assessment.

The details of the PORs of interest to this assessment are summarized in **Table 3-1** and illustrated in **Figure 3**.

Table 3-1 Summary of Noise Receptors

POR ID ¹	DESCRIPTION	LOCATION	RECEPTOR HEIGHT ABOVE GRADE (m)
R01_PW	1456 Coldrey Avenue - Westview Apartments (2.5 Storey)	Plane of nearest window	5.5
R02_PW	1464 Coldrey Avenue - Westview Apartments (2.5 Storey)	Plane of nearest window	5.5
R03_PW	1474 Coldrey Avenue - Westview Apartments (2.5 Storey)	Plane of nearest window	5.5
R04_PW	1443 Laperriere Avenue - Westview Apartments (2.5 Storey)	Plane of nearest window	5.5
R05_PW	1440 Laperriere Avenue – 2-storey semi-detached dwelling	Plane of nearest window	4.5
R06_PW	1470 Laperriere Avenue – 2-storey semi-detached dwelling	Plane of nearest window	4.5
R07_PW	1478 Laperriere Avenue – 2-storey single dwelling	Plane of nearest window	4.5
R08_PW	1496 Laperriere Avenue – 2-storey semi-detached dwelling	Plane of nearest window	4.5
R09_PW	1516 Laperriere Avenue – 2-storey semi-detached dwelling	Plane of nearest window	4.5

Notes:

¹ Refer **Figure 3** for receptor locations; locations are referred using these IDs.

4 NOISE GUIDELINES AND ASSESSMENT CRITERIA

Noise is recognized as a pollutant in the Environmental Protection Act, as uncontrolled noise can affect human activities. Ontario provincial noise control guidelines require that noise concerns are addressed in the planning of any new development.

In land use planning, although elimination or control of the source of pollution is usually a primary objective, there are general limits as to what is practical and technically possible. The City's ENCG follows the MECP's Publication NPC-300, *Environmental Noise Guideline Stationary and Transportation Sources – Approval and Planning* for acceptable levels of stationary noise on surrounding noise-sensitive residential areas. These limits are discussed in Section "Part C – Land Use Planning" of NPC-300 as well as Section 3 of the ENCG.

4.1 SOUND LEVEL DESCRIPTOR

For steady-state stationary sources, the MECP Publication NPC-300 and ENCG provides criteria based on one-hour energy equivalent sound level (L_{eq} -1 hour) in spectral (i.e. frequency based) as well as overall sound level; the overall sound level is described in units of A-weighted decibel. The L_{eq} is defined as the energy-equivalent sound level (L_{eq}) over a specified period of time, which is a one-hour period in this case, that would have the same sound energy as the actual (i.e., unsteady) time varying sound over the same period of time.

The sound levels for impulsive sources are expressed as L_{LM} which is the logarithmic average of the energy received at a receptor. Due to its average in nature, the overall impulsive sound level at a receptor would have a lower numerical result for a wide range of values.

4.2 SOUND LEVEL LIMITS

In order to comply, the predicted sound level from stationary sources must comply with the sound limits stipulated in the MECP publication, NPC-300 and ENCG.

Both guidelines provide sound level limits for receptors based on the acoustical environment in which the development is located. NPC-300 categorizes the acoustical environment into four classes: Class 1 (urban), Class 2 (suburban), Class 3 (rural), or Class 4 (special cases). This classification depends on the local land use and the existing ambient sound environment.

As per MECP's classification, the acoustical environment surrounding the Site is considered as MECP Class 1; in that the environment is dominated by anthropogenic sound during the daytime, evening and nighttime. This is due to the busy roads such as the Trans-Canada Highway 417 located adjacent to the proposed development.

4.2.1 STEADY-STATE (NON-IMPULSIVE)

Table 4-1 summarizes the ENCG and MECP exclusionary limits for steady-state sources in a Class 1 area.

Table 4-1 MECP Noise Criteria Exclusion Limits in dBA (Steady-State Sources)

TIME PERIOD	POINT OF RECEPTION	SOUND LEVEL LIMIT VALUES ($L_{EQ, 1-HR}$, dBA)
Daytime (07:00 – 19:00)	Outdoor ¹ and Plane of Window ²	50
Evening (19:00 – 23:00)	Outdoor ¹ and Plane of Window ²	50
Nighttime (23:00 – 07:00)	Plane of Window ²	45

Notes

¹ PoR means point of reception; representing a point in a receptor location as defined by MECP.

² Plane of window means a point in space corresponding with the location of the centre of a window of a noise sensitive space. The noise effects assessment excludes the effect of sound reflection from the plane of the window on which it is located. In general, the plane of a window is a point used for prediction (including extrapolation), rather than measurement, of sound levels (MOE 2013).

4.2.2 IMPULSIVE SOURCES

Products are typically on pallets which would be unloaded with a forklift. During unloading/loading activities at loading bays, there is potential that a ‘banging’ sound will be produced when a forklift enters the trailer; this sound is classified as an impulsive sound. Impulsive sounds are a category of sound which last for a brief time (typically a fraction of one second) and are measured and treated separately from non-impulsive sounds because of their special characteristics.

Table 4-2 summarizes the ENCG and MECP sound level limits for impulsive sources specific to this site based on the number of impulses anticipated at the Site.

Table 4-2 MECP Exclusion Limits in dBAI (Impulsive Sources)

TIME PERIOD	NUMBER OF IMPULSES IN PERIOD OF 1-HOUR	POINT OF RECEPTION	EXCLUSIONARY LIMIT VALUES (L_{LM} , dBAI)
Daytime (07:00 – 19:00)	9 or more	Outdoor ¹ and Plane of Window ²	50
Evening (19:00 – 23:00)	9 or more	Outdoor ¹ and Plane of Window ²	50
Nighttime (23:00 – 07:00)	9 or more	Plane of Window ²	45

Notes

¹ PoR means point of reception; representing a point in a receptor location as defined by MECP.

² Plane of window means a point in space corresponding with the location of the centre of a window of a noise sensitive space. The noise effects assessment excludes the effect of sound reflection from the plane of the window on which it is located. In general, the plane of a window is a point used for prediction (including extrapolation), rather than measurement, of sound levels (MOE 2013).

5 NOISE IMPACT ASSESSMENT

The objective of this acoustic assessment is to determine the Site's compliance as they relate to the applicable sound level limits during a predictable worst-case hour operation of the Site. This section discusses the assessment methodology, the modelling scenarios used, and the results of the assessment as well as the compliance of the Site with the MECP's and ENCG's limits.

5.1 ANALYSIS METHOD

In order to estimate the sound levels from the industrial and commercial area activities to the proposed residential receptors, a predictive analysis was completed using a commercially available software package CADNA/A, a computer implementation of the ISO Standard 9613-2 "Acoustics – Attenuation of Sound During Propagation Outdoors", which takes into account the following:

- Source sound power levels;
- Distance attenuation;
- Source-receptor geometry;
- Ground and air (atmospheric) attenuation;
- Temperature and humidity effects on noise propagation; and,

Hard ground overall ground absorption coefficient of 0 was used in the assessment due to the proposed site, roadways surrounding the area. One order of reflection was used in the assessment.

Key parameters used in the model and sample calculations are located in **Appendix C**.

5.2 PREDICTABLE WORST-CASE

The noise impact assessment requires that a predictable worst-case noise impact be assessed at each 1-hour period during the daytime, evening and nighttime hours; an assessment of the greatest noise impact at a POR when the facility is at capacity compared against acoustical environment during the quietest hour.

5.3 OPERATING SCENARIOS

Both proposed buildings, Building A and Building B, are self-storage facilities that are open to cliental 24 hours a day and 7 days a week. The operation of the facilities, including truck traffic and loading/unloading activities, is anticipated to be from 9 am to 5 pm. However, to be conservative, the assessment assumed that these activities occur between 7am and 11pm.

It should be noted that the predictable worst-case operating conditions over a 1-hour period, as required by the MECP, would not be expected to occur on a regular basis. The operating scenarios are described in **Table 5-1** below:

Table 5-1 Operating Scenarios

SCENARIO	SOURCE TYPE	BUSIEST 1-HOUR TIME PERIOD	DESCRIPTION OF ACTIVITIES
1	Steady-State (Non-Impulsive Sources)	Daytime (07:00 – 19:00) and Evening (19:00 – 23:00)	<ul style="list-style-type: none"> – All rooftop units operating at 100% duty cycle (operating 60 min per hour) – 15 heavy trucks entering and leaving the north loading area of Building A – 14 heavy trucks entering and leaving the loading area of Building B – Three (3) Heavy trucks idling (5 min per hour) at each loading area
2	Steady-State (Non-Impulsive Sources)	Nighttime (23:00 – 07:00)	<ul style="list-style-type: none"> – All rooftop units operating at 100% duty cycle (operating 60 min per hour)
3	Impulsive Sources	Daytime (07:00 – 19:00) and Evening (19:00 – 23:00)	<ul style="list-style-type: none"> – Forklift entering and exiting a trailer at the loading bays
4	Impulsive Sources	Nighttime (23:00 – 07:00)	<ul style="list-style-type: none"> – None

5.4 RESULTS

The results of the analysis were based on typical assumptions. It is recommended that the noise assessment be reviewed when more detailed information, such as tenant information, mechanical design and final equipment selection becomes available.

5.4.1 STEADY-STATE (NON-IMPULSIVE) SOUND

The overall steady-state sound levels at the representative PORs for the predictable worst-case operations of the Site are summarized in **Table 5-2**. Sound levels attributable to the operation of the Site were compared to the applicable sound level limits.

Table 5-2 Predicted Sound Levels from Stationary Sources

POR ID	PREDICTED HOURLY SOUND LEVELS, dBA		CLASS 1 MECP SOUND LEVEL LIMITS, dBA		COMPLIANCE WITH MECP LIMIT
	DAY/EVE	NIGHT	DAY/EVE	NIGHT	
R01_PW	36	32	50	45	Yes
R02_PW	37	33	50	45	Yes
R03_PW	39	33	50	45	Yes
R04_PW	41	33	50	45	Yes
R05_PW	40	31	50	45	Yes
R06_PW	39	31	50	45	Yes
R07_PW	36	32	50	45	Yes
R08_PW	40	32	50	45	Yes
R09_PW	30	29	50	45	Yes

As shown in the table above, the sound levels attributable to the operation of the Site meets the sound level limits at all the receptors for daytime, evening and nighttime hours without the need for noise mitigation measures. Sound level contours are presented in **Figure 4** for Daytime and Evening and **Figure 5** for Nighttime, at a height of 4.5 m above grade.

5.4.2 IMPULSIVE SOUND

This assessment considered the predictable worst-case operating scenario as the loading/unloading activities were assessed separately and at the worst-case locations. Only the daytime and evening hours were analysed at the loading areas. Impulsive sound levels at the nearby PORs due to loading and unloading activities were assessed separately for each loading area. It should be noted that this is considered conservative as impulsive sound levels at the receptors are averaged logarithmically which would normally result to lower sound levels.

The overall impulsive sound levels at the representative PORs for the predictable worst-case operations of the Site are summarized in **Table 5-3** below. Impulsive sound levels attributable to the operation of the Site were compared against the applicable sound level limits in the daytime when the forklifts are operational at each of the three loading areas: Building A North, Building A South, and Building B.

As shown in table below, the Facility will comply at all points of reception during the daytime hours for the activities associated with the loading and/or unloading. **Figure 6** shows Building A Southeast loading area which has the highest predicted impulsive sound levels at the receptors level contours at a height of 4.5 m above grade.

Table 5-3 Predicted Sound Levels from Impulsive Sources

POR ID	PREDICTED IMPULSIVE SOUND LEVELS (L _{LM} , dBAI)			CLASS 1 MECP SOUND LEVEL LIMITS (L _{LM} , dBAI)	COMPLIANCE WITH MECP LIMIT
	DAY / EVE			DAY / EVE	
	Building A North	Building A South	Building B		
R01_PW	20	42	22	50	Yes
R02_PW	20	42	22	50	Yes
R03_PW	20	44	21	50	Yes
R04_PW	27	45	22	50	Yes
R05_PW	21	48	31	50	Yes
R06_PW	27	48	27	50	Yes
R07_PW	34	38	27	50	Yes
R08_PW	44	32	26	50	Yes
R09_PW	27	26	22	50	Yes

6 CONCLUSIONS

An assessment of potential noise impacts of stationary sources of a proposed a commercial development, to be located at 864 Lady Ellen Place in Ottawa, Ontario. The report was prepared in support of a Site Plan Control Application (SPCA) submission to the City of Ottawa. The sound levels attributable to the proposed development are predicted to comply with the sound level limits outlined by the ENCG and the MECP at the surrounding properties. Since the analysis was based on typical assumptions, this study will need to be updated once detailed information such as mechanical design, equipment selection and operating scenarios become available. The Site's operation is not considered a significant source of vibration; therefore, a vibration assessment was not included.

APPENDIX

A DRAWINGS



CONSULTANT - SUB CONSULTANT

CONSULTANT - SUB CONSULTANT

CONSULTANT - SUB CONSULTANT

CONSULTANT - SUB CONSULTANT

CONSULTANT - SUB CONSULTANT

CONSULTANT - SUB CONSULTANT

CONSULTANT - SUB CONSULTANT

CONSULTANT - SUB CONSULTANT

CONSULTANT - SUB CONSULTANT

CONSULTANT - SUB CONSULTANT

CONSULTANT - SUB CONSULTANT

CONSULTANT - SUB CONSULTANT

CONSULTANT - SUB CONSULTANT

CONSULTANT - SUB CONSULTANT

CONSULTANT - SUB CONSULTANT

CONSULTANT - SUB CONSULTANT

CONSULTANT - SUB CONSULTANT

CONSULTANT - SUB CONSULTANT

CONSULTANT - SUB CONSULTANT

CONSULTANT - SUB CONSULTANT

CONSULTANT - SUB CONSULTANT

CONSULTANT - SUB CONSULTANT

CONSULTANT - SUB CONSULTANT

CONSULTANT - SUB CONSULTANT

CONSULTANT - SUB CONSULTANT

CONSULTANT - SUB CONSULTANT

CONSULTANT - SUB CONSULTANT

CONSULTANT - SUB CONSULTANT

CONSULTANT - SUB CONSULTANT

CONSULTANT - SUB CONSULTANT

CONSULTANT - SUB CONSULTANT

CONSULTANT - SUB CONSULTANT

CONSULTANT - SUB CONSULTANT

CONSULTANT - SUB CONSULTANT

CONSULTANT - SUB CONSULTANT

CONSULTANT - SUB CONSULTANT

CONSULTANT - SUB CONSULTANT

LAYOUT NOTES:

- CONTRACTOR TO CONFIRM ALL DIMENSIONS AND REPORT ANY DISCREPANCIES TO CONTRACTOR ADMINISTRATOR PRIOR TO CONSTRUCTION
- LAYOUT TO BE APPROVED BY CONTRACT ADMINISTRATOR PRIOR TO ANY CONSTRUCTION OR REMOVALS
- ALL DIMENSIONS ARE IN METRIC UNLESS OTHERWISE NOTED
- CONTRACTOR IS RESPONSIBLE FOR ALL EXCAVATIONS, REMOVALS, DISPOSALS AND ROUGH GRADING AS REQUIRED TO CONSTRUCTION ALL WORKS AS SHOWN ON ALL PLANS, DETAILS AND SPECIFICATIONS
- LOCATION OF ALL UTILITIES SHOWN FOR ILLUSTRATION ONLY. CONTRACTOR MUST CONTACT ALL UTILITIES REGARDING RULES FOR WORKING IN THE AREA OF THE UTILITIES PRIOR TO COMMENCEMENT OF ANY WORK. CONTRACTOR MUST CONFIRM LOCATION OF ALL UTILITIES PRIOR TO CONSTRUCTION
- ALL EXISTING ROADS, SIDEWALKS, CURBS, FENCING, PAVING, SODDED AREAS, AND APPROACHES, ETC. TO REMAIN TO BE PROTECTED DURING CONSTRUCTION TO CONTRACT ADMINISTRATOR'S APPROVAL AT THE CONTRACTOR'S OWN COSTS.
- ALL EXISTING TREES, SHRUB BEDS, MULCH BEDS, AND SOD TO REMAIN TO BE PROTECTED DURING CONSTRUCTION. AREAS DAMAGED DURING CONSTRUCTION TO BE REPAIRED TO CONTRACT ADMINISTRATOR'S APPROVAL AT THE CONTRACTOR'S OWN COST.
- USE SPECIFIED BACKFILL IN ALL TRENCHES RUNNING BELOW ALL STRUCTURES, PAVING, WALKWAYS, ETC.
- FILL ALL HOLES AND LOW AREAS TO DESIGN SUBGRADE WITH COMPACTED FILL (SUITABLE TO SURFACE FINISH), FOR SODDED/PLANTED AREAS USE COMPACTED CLEAN EARTH FILL SUITABLE FOR PLANT GROWTH. FOR PAVED AREAS USE COMPACTED GRANULAR BASE.
- ALL TREES WITHIN OR IMMEDIATELY ADJACENT TO AREA OF WORK TO BE PROTECTED TO CITY OF OTTAWA TREE PROTECTION STANDARDS.

PARKING REQUIREMENTS:

- WAREHOUSE:
 - 0.4 PER 100m² FOR THE FIRST 5000m² GROSS FLOOR AREA,
 - 0.4 PER 100m² ABOVE 5000m² GROSS FLOOR AREA.
 - = 71 SPACES
- ACCESSIBLE PARKING REQ.:
 - 1 TYPE A
 - 2 TYPE B
- TOTAL PARKING PROVIDED:
 - 74 SPACES PROVIDED (71 REQ.)
 - 7 LOADING SPACES PROVIDED (3 REQ.)
- BICYCLE PARKING:
 - 1 STALL PER 2000m² GROSS FLOOR AREA
 - 10 SPACES PROVIDED (9 REQ.)

LEGEND:

- TOPSOIL AND SOD
- PLANT BED
- CONCRETE SIDEWALK
- HEAVY DUTY ASPHALT PAVEMENT
- LIGHT DUTY ASPHALT PAVEMENT
- PAINTED LINES
- SNOW REMOVAL AREA
- TOPSOIL AND NATIVE GRASS SEED MIX
- TOPSOIL AND DEEP ROOTING GRASS SEED MIX
- TOPSOIL AND POLLINATOR SEED MIX
- 3/4" RIVER STONE MULCH
- 2-4" RIVER STONE MULCH
- PROPERTY LINE
- EASEMENT LINE
- BUILDING OVERHANG
- EXISTING CHAINLINK FENCE
- APPROXIMATE AREA OF WORK
- EXISTING CURB
- NEW CURB
- ACCESSIBLE PARKING STALL

KEYNOTES:

- CONCRETE SIDEWALK. REFER TO DETAIL 4/L300
- ACCESSIBLE RAMP WITH TACTILE WARNING SURFACE INDICATOR (TWS)
- 150mm HT CONCRETE CURB. REFER TO DETAIL 5/L300
- ASPHALT PARKING LOT. REFER TO CIVIL FOR DETAIL.
- TYPE A PARKING STALL
- TYPE B PARKING STALL
- PROPOSED GARBAGE ENCLOSURE. REFER TO DETAIL 11/L300
- SNOW REMOVAL STORAGE AREA
- EXISTING FIRE HYDRANT
- 3/4" RIVER STONE MULCH.
- 2-4" RIVER STONE MULCH.
- 316 STAINLESS STEEL BICYCLE RACKS. REFER TO DETAIL 10/L300
- SODDED AREA. REFER TO DETAIL 6/L300
- PAINTED CROSSWALK
- PAINTED ISLAND
- SIGNAGE
- LOADING SPACE
- SEEDDED AREA. REFER TO DETAIL 6/L300

ZONING STATISTICS

SITE INFORMATION:
 LEGAL DESCRIPTION:
 Lots 9, 10, 11, 12, and Part of Lot 13,
 Registered Plan 387939, City of Ottawa

EASEMENTS:
 Inst. CR388144, Plan 387939
 Inst. CR621418, Part 8 Plan 4R-29611
 Inst. OC201490, By-law 2003-162
 Inst. N430098 (L1609535)

MUNICIPAL ADDRESS: 864 Lady Ellen Place, Ottawa, Ontario

LOT AREA: 13,576.785 m² (146,144.07 sq.ft.)

BUILDING GROSS FLOOR AREAS:
 Existing 3,529 m²
 Proposed 17,663 m²

ZONING INFORMATION:
 ZONE: Light Industrial Zone, Urban Exception 278,
 Height Limit 30 (L1 [278] H(30))
 Sec. 203(3), Table 203

PROPOSED LOT COVERAGE: 39.3% (Maximum allowable 65%)

BUILDING HEIGHT:
 Building 'A' 23m (Maximum allowable 30m)
 Building 'B' 7m (Maximum allowable 30m)

FLOOR SPACE INDEX: 1.3 (Maximum allowable 2)

BUILDING SETBACKS:
 Building 'A' Setbacks:
 Min. Front Yard: 7.5 m (7.5 m required)
 Min. Interior Side Yard: 15 m (7.5 m required)
 Min. Rear Side Yard: 8.88 m (3.5 m required)

Building 'B' Setbacks:
 Min. Front Yard: 7.5 m (7.5 m required)
 Min. Interior Side Yard: 7.5 m (7.5 m required)
 Min. Rear Yard: 14 m (3.5 m required)

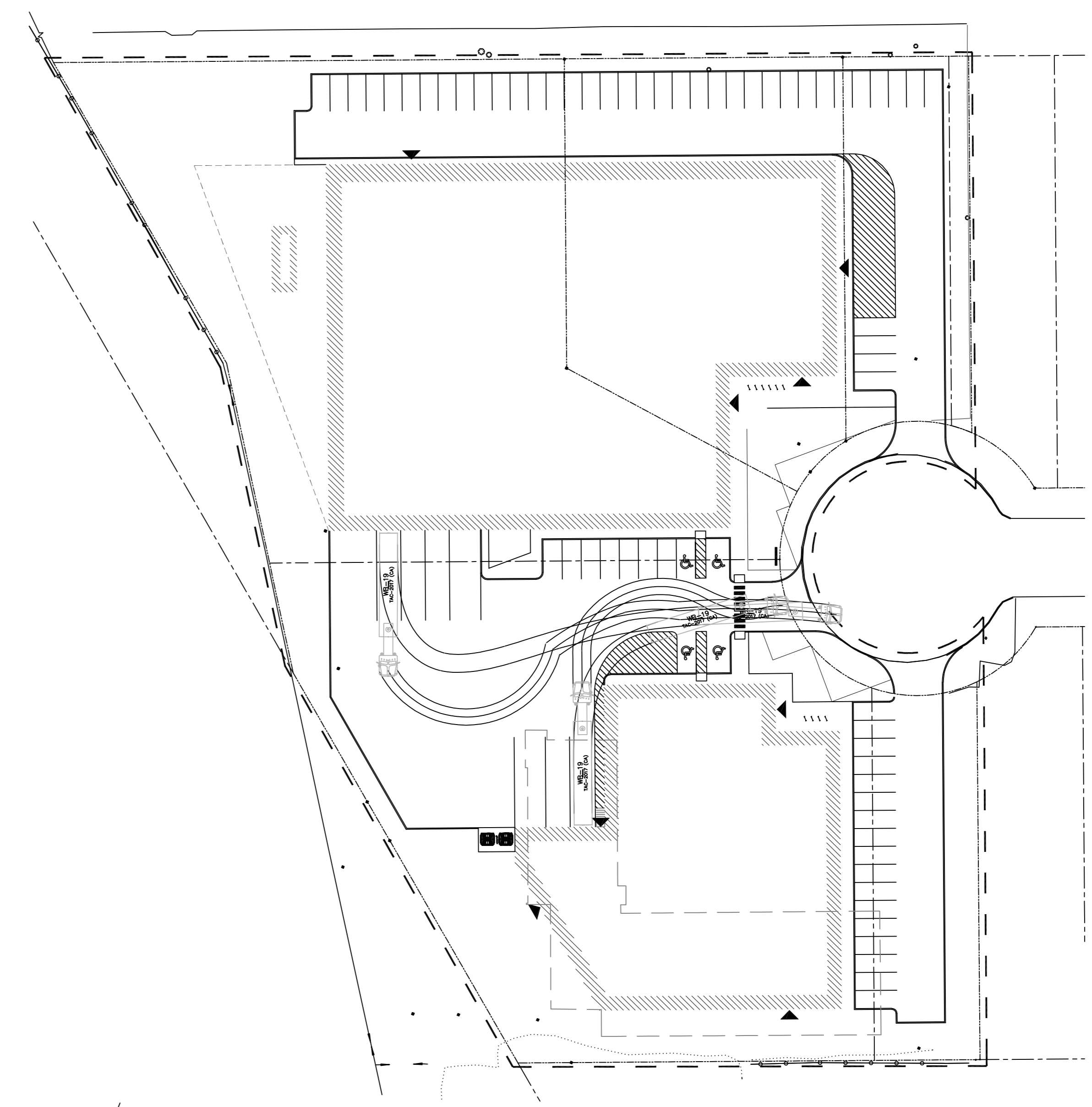

1 VEHICLE TURNING MOVEMENTS
 L100 1:500

11 10 9 8 7 6 5 4 3 2 1

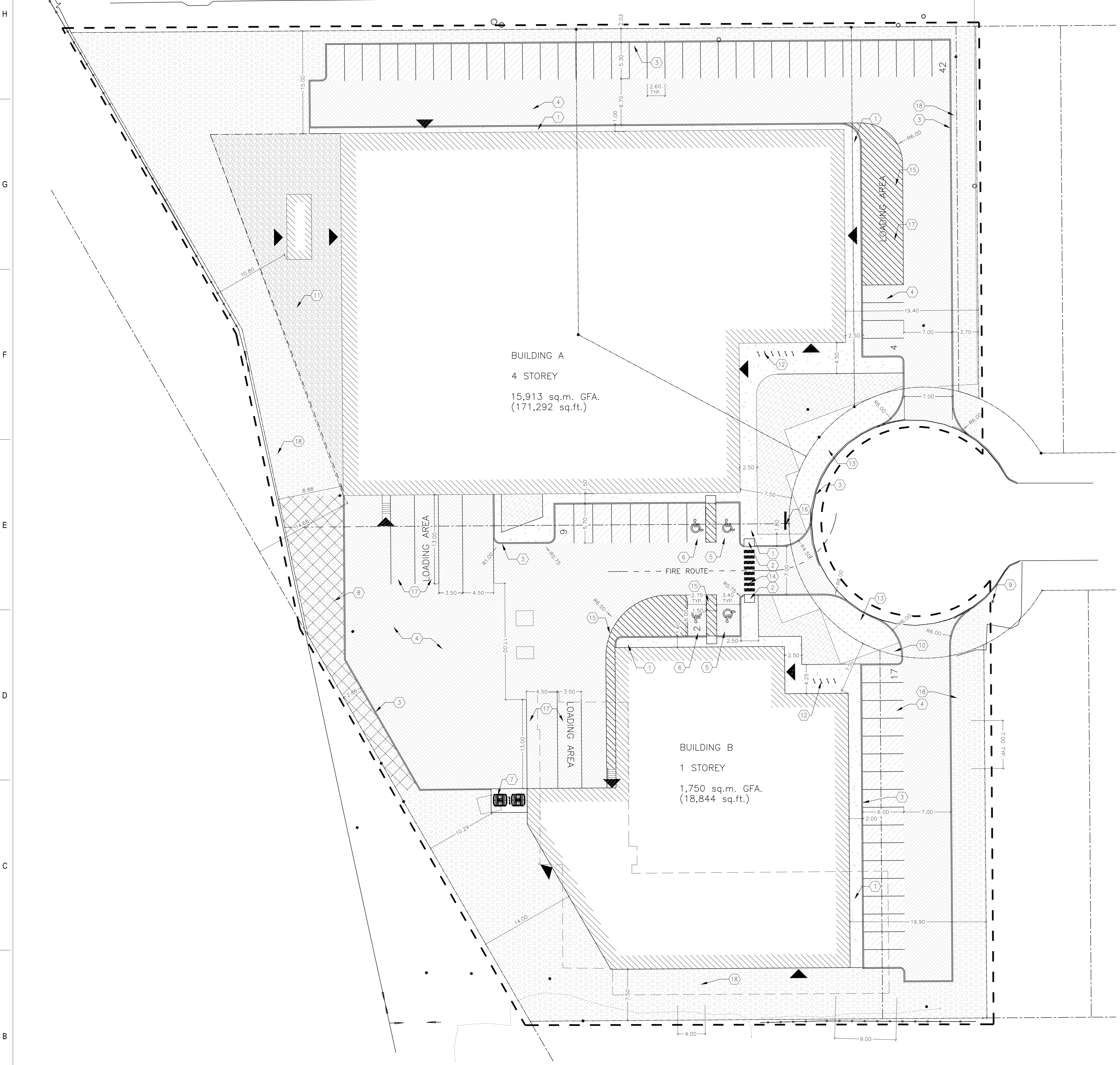

1 SITE PLAN
 L100 1:250

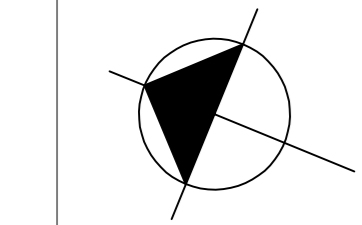

H G F E D C B A

11 10 9 8 7 6 5 4 3 2 1

PROPOSED SELF-STORAGE
 LADY ELLEN PLACE

KEY PLAN

DISCLAIMER:
 THE DRAWING AND DESIGN IS COPYRIGHT PROTECTED BY ARCHITECTURE 49. ANY REPRODUCTION OR USE OF THIS DRAWING WITHOUT THE WRITTEN PERMISSION OF ARCHITECTURE 49 IS STRICTLY PROHIBITED. CHECK AND VERIFY ALL DIMENSIONS AND UTILITY LOCATIONS AND REPORT ALL ERRORS AND OMISSIONS PRIOR TO COMMENCING WORK.
 THIS DRAWING IS NOT TO BE SCALED.

ISSUED FOR: REVISION:

NO.	DATE	ISSUES FOR RPA	DESCRIPTION
1	11/09/2022		
2	11/09/2022		

PROJECT NO: 219-00028-09 DATE: 2022-11-29

ORIGINAL SCALE: As Indicated
 DESIGNED BY: AH
 DRAWN BY: SG
 CHECKED BY: AH

DISCIPLINE: LANDSCAPE ARCHITECTURE

TITLE: SITE PLAN

SHEET NUMBER: A100 OF

DATE: 09/2022

DATE: 09/2022

APPENDIX

B

SUPPORTING
DOCUMENTATION

PRODUCT SPECIFICATIONS

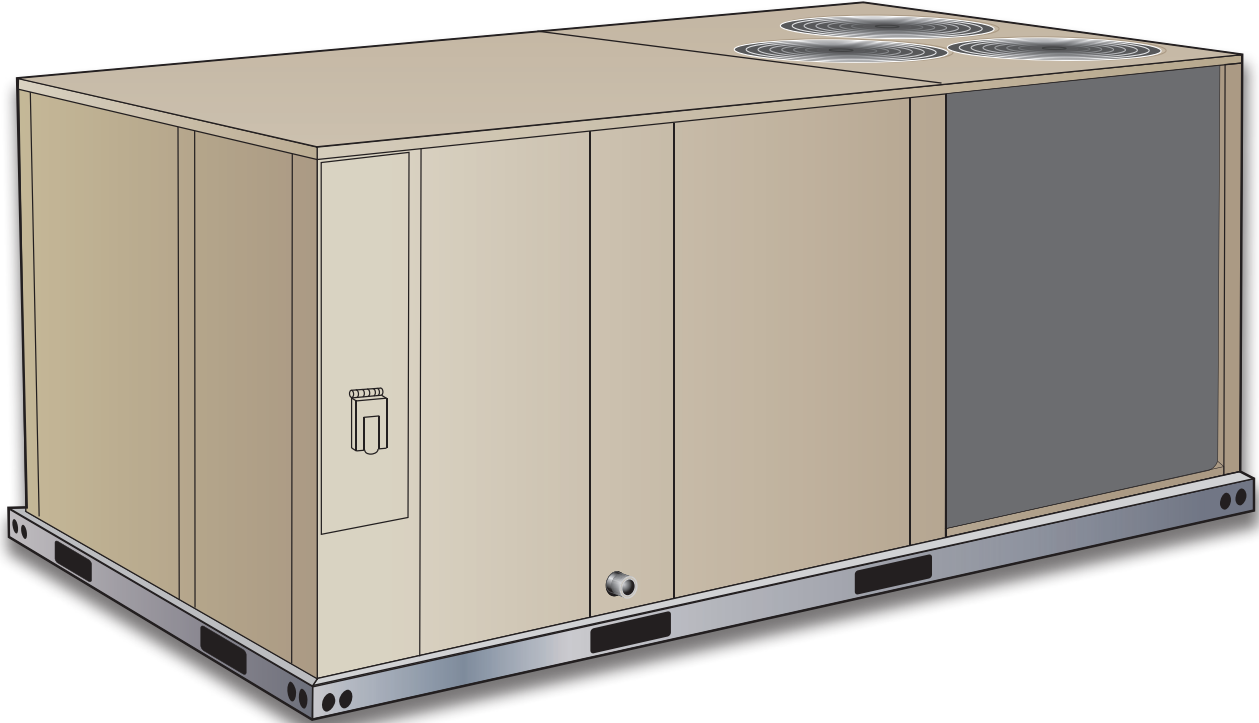

**ASHRAE 90.1
COMPLIANT**

7.5 to 10 Tons

Net Cooling Capacity – 89,000 to 138,000 Btuh

Net Heating Capacity - 86,000 to 138,000 Btuh

Gas Input Heat Capacity – 130,000 to 240,000 Btuh

MODEL NUMBER IDENTIFICATION

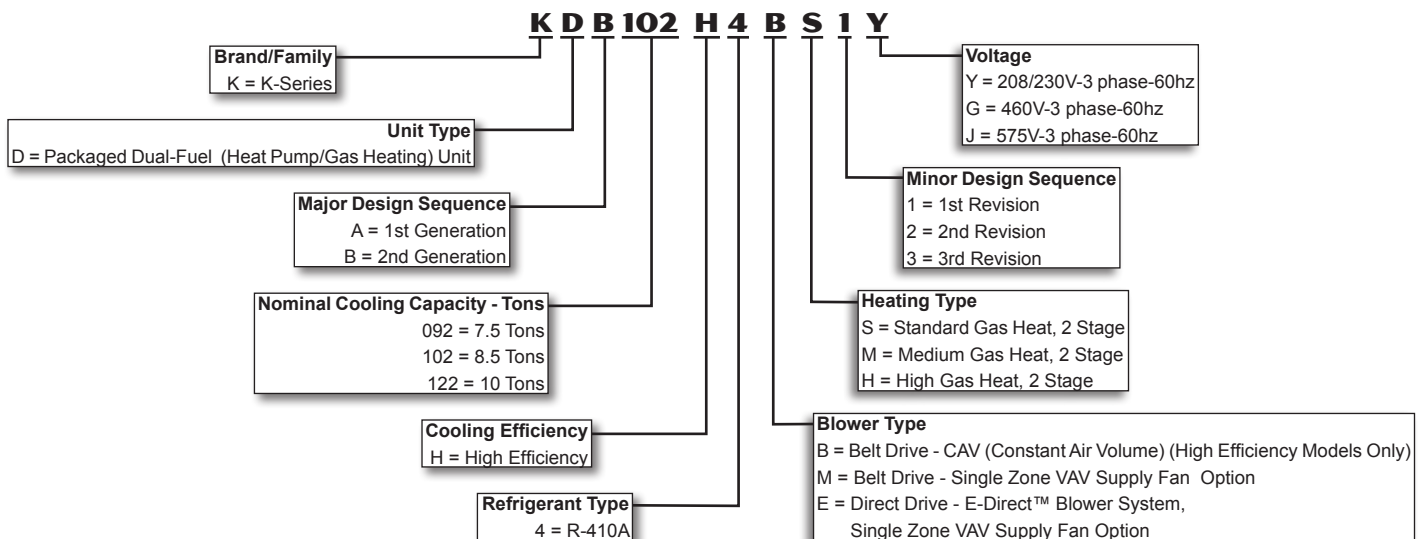

FEATURES AND BENEFITS

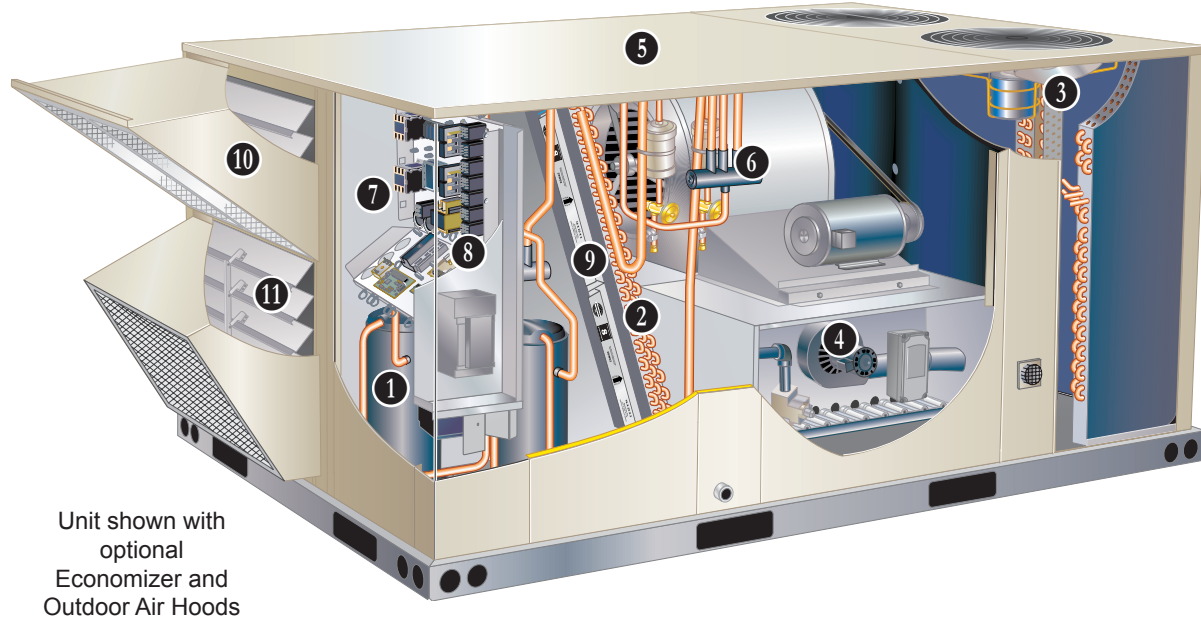

K-Series™ rooftop units from Allied are the new standard for reliable, efficient rooftop units built for long-lasting performance that can significantly improve indoor environments. K-Series™ rooftop units feature:

- **Dual-Fuel** - Alternates between mechanical heat pump heating and gas heating depending on outdoor conditions.
- **R-410A Refrigerant** - Environmentally friendly.
- **Scroll Compressors** - Single speed scroll compressors are furnished on all models.
- **High Pressure Switches** - Protect compressor.
- **Isolated Compressor Compartment** - Allows performance check during normal compressor operation without disrupting airflow.
- **Independent Outdoor Fan Motor Mounts** - Allows for easy and efficient service access without removing the top panel.
- **Constant Air Volume (CAV) or Single Zone VAV Supply Fan Blower Option** - Allows constant or multi-staged air delivery.
- **E-Direct™ Blower System (KDB122 Direct Drive Models Only)** - High-efficiency, variable-speed ECM motor combined with an aerodynamically optimized impeller for quiet operation.
- **Downflow or Horizontal Airflow** - Easy field conversion.
- **Two Fork Lift Slots on Three Sides** - Easy to pick up and transport units from almost any angle.
- **Corrosion-Resistant Removable, Reversible Drain Pan** - Provides application flexibility, durability and improved serviceability.
- **Thermostatic Expansion Valves** - Provide peak cooling performance across the entire application range.
- **MERV 8 or MERV 13 Filters** - Available as field installed option, provide an enhanced level of indoor air quality, and can help the building qualify for additional LEED credits.
- **Common Components** - Many maintenance items are standard throughout the entire product line, reducing the need to carry different parts to the job or maintain in inventory.

FEATURES AND BENEFITS

CONTENTS

Blower Data - Direct Drive21
Cooling/Heating Ratings15
Dimensions - Accessories.31
Dimensions - Unit - 092-102 Models29
Electrical Data.24
Features And Benefits	2
Model Number Identification	1
Optional Conventional Temperature Control Systems27
Options / Accessories.10
Outdoor Sound Data26
Specifications13
Specifications - Gas Heat.14
Unit Clearances.26
Weight Data.28

APPROVALS

AHRI Certified to AHRI Standard 340/360-2007.

Units are ETL listed.

Units are certified by CSA.

Components bonded for grounding to meet safety standards for servicing required by UL, ULC and National and Canadian Electrical Codes.

All models are ASHRAE 90.1-2010 energy efficiency compliant and meet or exceed requirements of Section 6.8.

Models equipped with the Single Zone VAV Supply Fan and E-Direct™ options meet California Code of Regulations, Title 24 and ASHRAE 90.1-2010 Section 6.4.3.10 requirements for staged airflow.

ISO 9001 Registered Manufacturing Quality System.

WARRANTY

Limited five years on compressors.

Limited fifteen years on stainless steel heat exchanger.

Limited five years Optional High Performance Economizers.

Limited one year all other covered components.

DUAL-FUEL OPERATION

In heating mode the heat pump operates the heat pump for 1st stage heating. If 1st stage is not satisfied, the 2nd stage will activate gas heating (secondary heat source). Mechanical heat pump operation is automatically terminated on gas heat start-up.

Unit control automatically changes blower speeds between heat pump heating and gas heat operation. Blower operates in high speed during 1st stage (heat pump) operation and is terminated during changeover to gas heat operation.

Blower starts up when heat exchanger is warm, and runs in high speed during 2nd stage (gas heat) operation.

If continuous blower operation is available on thermostat, change in blower speed automatically occurs during heat pump heat to gas heat changeover.

COOLING/HEATING SYSTEM

Designed to maximize sensible and latent cooling performance at design conditions.

System can operate in the cooling mode from 30°F to 125°F without any additional controls.

R-410A Refrigerant

Non-chlorine based, ozone friendly, R-410A.

1 Scroll Compressors

Scroll compressors on all models for high performance, reliability and quiet operation.

Resiliently mounted on rubber grommets for quiet operation.

Compressor Crankcase Heaters

Protects against refrigerant migration that can occur during low ambient operation.

Check/Thermal Expansion Valves

Assures optimal performance throughout the application range. Removable element head.

Reversing Valves

4-way interchange reversing valve effects a rapid change in direction of refrigerant flow resulting in quick changeover from cooling to heating and vice versa.

Filter/Driers

High capacity filter/drier protects the system from dirt and moisture.

High Pressure Switches

Protects the compressor from overload conditions such as dirty condenser coils, blocked refrigerant flow, or loss of outdoor fan operation. Auto-reset.

Freezestats

Protects the evaporator coil from damaging ice build-up due to conditions such as low/no airflow, or low refrigerant charge.

FEATURES AND BENEFITS

COOLING/HEATING SYSTEM **(continued)**

2 **Coil Construction**

Copper tube construction, enhanced rippled-edge aluminum fins, flared shoulder tubing connections, silver soldered construction for improved heat transfer. Factory leak tested.

Indoor Coil

Cross row circuiting with rifled copper tubing optimizes both sensible and latent cooling capacity.

Condenser Coil

Two independent formed coils allow separation for cleaning.

Condensate Drain Pan

Plastic pan, sloped to meet drainage requirements of ASHRAE 62.1.

Side or bottom drain connections.

Reversible to allow connection at back of unit.

Outdoor Coil Fan Motors

All models have variable speed (ECM) fan motors for energy efficient operation and quiet operation.

Thermal overload protected, totally enclosed, permanently lubricated ball bearings, shaft up, wire basket mount.

3 **Outdoor Coil Fans**

PVC coated fan guard furnished.

Required Selections

Cooling Capacity

Specify nominal cooling capacity of the unit

Options/Accessories

Field Installed

Condensate Drain Trap

Available in copper or PVC.

Drain Pan Overflow Switch

Monitors condensate level in drain pan, shuts down unit if drain becomes clogged.

Low Ambient Kit

Designed for use in ambient temperatures no lower than 0°F. Cycles the outdoor fans while allowing compressor operation in the cooling cycle. Includes field installed pressure switches on the liquid line to determine when to operate the outdoor fans. This intermittent fan operation allows the system to operate without icing the evaporator coil and losing capacity.

If the liquid line pressure drops below 240 psig outdoor fans operate at 25% normal fan speed. If pressure drops below 180 psig all outdoor fans stop until pressure rises to 300 psig, then fans operate at 25% normal fan speed unless main pressure switches have reset to 450 psig to resume normal cooling operation and full fan speed operation.

GAS HEATING SYSTEM

Aluminized steel inshot burners, direct spark ignition, electronic flame sensor, combustion air inducer, redundant automatic dual stage gas valve with manual shut-off.

4 **Heat Exchanger**

Tubular construction, stainless steel, life cycle tested.

Electronic Pilot Ignition

Electronic spark igniter provides positive direct ignition of burners on each operating cycle. The system permits main gas valve to stay open only when the burners are proven to be lit. Should a loss of flame occur, the gas valve closes, shutting off the gas to the burners. Ignition module has an LED to indicate status and aid in troubleshooting.

Watchguard circuit on module automatically resets ignition controls after one hour of continuous thermostat demand after unit lockout, eliminating nuisance service calls.

Ignition control is factory installed in the controls section.

Limit Control

Factory installed, limit control with fixed temperature setting. Heat limit control protects heat

exchanger and other components from overheating.

Safety Switches

Flame roll-out switch, flame sensor and combustion air inducer proving switch protect system operation.

Required Selections

Gas Input Choice - Order one:

Standard Gas Heat, 2 Stage
(84,500/130,000 Btuh)

Medium Gas Heat, 2 Stage
(117,000/180,000 Btuh)

High Gas Heat, 2 Stage
(156,000/240,000 Btuh)

Options/Accessories

Field Installed

Bottom Gas Piping Kit

Allows bottom gas entry.

Combustion Air Intake Extensions

Recommended for use with existing flue extension kits in areas where high snow areas can block intake air.

Low Temperature Vestibule Heater

Electric heater automatically controls minimum temperature in gas burner compartment when temperature is below -40°F. CSA certified to allow operation of unit down to -60°F.

LPG/Propane Kits

Conversion kit to field change over units from Natural Gas to LPG/Propane.

Options/Accessories

Field Installed

Vertical Vent Extension Kit

Use to exhaust flue gases vertically above unit. Required when unit vent is too close to fresh air intakes per building codes. The vent kit also prevents ice formation on intake louvers.

Kit contains vent transition, vent tee, drain cap and installation hardware.

NOTE - Straight vent pipes (4 in. B-Vent) and caps are not furnished and must be field supplied. Refer to kit instructions for additional information.

FEATURES AND BENEFITS

CABINET

5 Construction

Heavy-gauge steel panels and full perimeter heavy-gauge galvanized steel base rail provides structural integrity for transportation, handling, and installation.

Base rails have rigging holes.

Three sides of the base rail have forklift slots.

Raised edges around duct and power entry openings in the bottom of the unit provide additional protection against water entering the building.

Airflow Choice

Units are shipped in downflow (vertical) configuration, can be field converted to horizontal airflow with optional Horizontal Discharge Kit.

Duct Flanges

Provided for horizontal duct attachment.

Power/Gas Entry

Electrical and gas lines can be brought through the unit base or through horizontal access knock-outs.

Exterior Panels

Constructed of heavy-gauge, galvanized steel with a two-layer enamel paint finish.

Insulation

All panels adjacent to conditioned air are fully insulated with non-hygroscopic fiberglass insulation.

Unit base is fully insulated in conditioned area. The insulation also serves as an air seal to the roof curb, eliminating the need to add a seal during installation.

Access Panels

Access panels are provided for the filter section, heating/blower section, and the compressor/controls section.

Options/Accessories

Factory Installed

Corrosion Protection

A completely flexible immersed coating with an electrodeposited dry film process (AST ElectroFin E-Coat). Meets Mil Spec MIL-P-53084, ASTM B117 Standard Method Salt Spray Testing.

Indoor Corrosion Protection:

- Coated coil
- Painted blower housing
- Painted base

Outdoor Corrosion Protection:

- Coated coil
- Painted base

Hinged Access Panels

Large access panels are hinged and have quarter-turn latches for quick and easy access to maintenance areas (filter, compressor / controls, heating / blower).

Field Installed

Combination Coil/Hail Guards

Heavy gauge steel frame painted to match cabinet with expanded metal mesh to protect the outdoor coil from damage.

Horizontal Discharge Kit

Consists of duct covers to block off downflow supply and return air openings for horizontal applications.

Also includes return air duct flanges for end return air when economizer is used in horizontal applications.

NOTE - When configuring unit for horizontal application with economizer, a separate Horizontal Barometric Relief Damper with Hood must be ordered separately for installation in the return air duct. **Return Air Adaptor Plate**

For same size LC/LG/LH and TC/TG/TH unit replacement.

Installs on return air opening in unit to match return air opening on existing roof curbs. Also see Accessory Air Resistance table.

6 BLOWER

A wide selection of supply air blower options are available to meet a variety of airflow requirements.

Belt Drive Blower System (All Models Except KDB122)

Overload protected, equipped with ball bearings. Belt drive motors are available in several different sizes to maximize air performance.

Forward curved blades, double inlet, blower wheel is statically and dynamically balanced. Equipped with ball bearings and adjustable pulley (allows speed change).

Blower assembly slides out of unit for servicing.

E-Direct™ Blower System (KDB122 Models Only)

High-efficiency, variable-speed ECM (electronically commutated) motor with an aerodynamically optimized impeller with backward curved blades mounted directly onto the rotor.

Design combines the motor and electronics into one unit, eliminating the need for a variable-frequency drive.

Maintains the ability to ramp up or down the blower to meet comfort needs.

Blower assembly slides out of unit for servicing.

Air inlet grill reduces indoor sound levels without affecting air performance.

Required Selections

Select Belt Drive Constant Air Volume (CAV) or Single Zone VAV Supply Fan Supply Air Blower Option

(All Models except KDB122)
Order blower motor horsepower and drive kit number required when base unit is ordered, see Drive Kit Specifications Table.

Or Select E-Direct™ (KDB122 Models Only)

FEATURES AND BENEFITS

BLOWER (continued)

CAV Operation

On units ordered with the Constant Air volume (CAV) option, the supply air blower will provide a constant volume of air.

Single Zone VAV Supply Fan Operation

Units ordered with the Single Zone VAV Supply Fan option utilize a Variable Frequency Drive (VFD) to stage the supply air blower airflow. The VFD alters the frequency and voltage of the power supply to the blower to control blower speed.

The supply air blower has two speeds:

1. Low speed for part-load cooling operation. Note - Low speed is 66% of high speed.
2. High speed for full load cooling and all heat modes.

Full speed blower operation is set by adjusting the motor pulley to deliver the desired air volume.

The ventilation speed is selectable between high and low speed.

*NOTE - Part load airflow in cooling mode on **Single Zone VAV Supply Fan** units should not be set below 220 cfm/nominal full load ton to reduce the risk of evaporator coil freeze-up.*

The VFD has an operational range of -40 to 125° F outdoor air ambient temperature.

Lower operating costs are obtained when the blower is operated on lower speeds.

Single Zone VAV Supply Fan Sequence of Operation

Ventilation speed is determined by the VENT SPEED switch setting on fan control board (LO or HI).

Blower operates in low speed for mechanical cooling (Y1).

Blower operates in high speed for any other mode (free cooling, mechanical cooling Y1+Y2, and heating).

Economizer damper minimum position is fully closed in unoccupied mode.

In occupied mode, the economizer damper minimum position is determined by the setting of the two potentiometers on fan control board.

- LO SPD MIN POS potentiometer sets the minimum position when blower is operating at low speed.
- HI SPD MIN POS potentiometer sets the minimum position when blower is operating at high speed.

Options/Accessories

Field Installed

VFD Manual Bypass Kit

VFD Manual Bypass Control is available as a kit for units equipped with the Single Zone VAV Supply Fan option.

The VFD Manual Bypass Control is a manual bypass and is set by re-configuring the wiring on the unit.

CONTROLS

7 Unit Control

All control voltage is provided via a 24V (secondary) transformer with built-in circuit breaker protection.

Heat/Cool Staging - Capable of up to 2 heat / 2 cool staging with a third party DDC control system or thermostat.

Low Voltage Terminal Block -

Provides screw terminal connections for thermostat or controller wiring.

Night Setback Mode - Saves energy by closing outdoor air dampers and operating supply fan on thermostat demand only.

Defrost Control

Provides a defrost cycle, if needed, every 30 or 60 or 90 minutes (adjustable) of compressor on¹ time at outdoor coil temperature below 35°F. Temperature switch mounted on outdoor coil liquid line terminates defrost cycle.

NOTE - Gas heating operates during a defrost cycle.

Fan Control (E-Direct™ Blower System Only)

Provides variable speed control. Blower speed can be independently set for both full load and part load applications. Outdoor fan motor speed will vary depending on full or part load applications.

Balance Point Thermostat

Controls the changeover temperature between the heat pump heating operation and gas heat heating operation.

Options/Accessories

Field Installed

Smoke Detector

Photoelectric type, installed in supply air section, return air section or both sections. Available with power board and single sensor (supply or return) or power board and two sensors (supply and return).

Thermostats

Control system and thermostat options, see page 27.

Aftermarket unit controller options, see Options/Accessories table.

FEATURES AND BENEFITS

ELECTRICAL

Marked & Color-Coded Wiring

All electrical wiring is color-coded and marked to identify which components it is connecting.

Electrical Plugs

Positive connection electrical plugs are used to connect common accessories or maintenance parts for easy removal or installation.

Phase Monitor

(Factory Installed on Units Equipped with the Single Zone VAV Supply Fan and E-Direct™ Option)

Phase monitor located in the control compartment detects the phasing of incoming power. If the incoming power is out of phase or if any of the three phases are lost, an indicator LED on the phase monitor will turn red and the unit will not start. In normal operation with correct incoming power phasing, the LED will be green.

Required Selections

Voltage Choice

Specify when ordering base unit.

Options/Accessories

Factory or Field Installed

8 Disconnect Switch

Accessible from outside of unit, spring loaded weatherproof cover furnished. Main power to the unit is field connected to the disconnect which allows all power to be shut off for service. See Electrical Data tables for ordering information, page 24.

GFI Service Outlets (2)

115V ground fault circuit interrupter (GFCI) type, non-powered, field-wired.

Field Installed

GFI Weatherproof Cover

Single-gang cover.

Heavy-duty UV-resistant polycarbonate case construction.

Hinged base cover with gasket.

INDOOR AIR QUALITY

9 Air Filters

Disposable 2-inch filters furnished as standard.

Options/Accessories

Field Installed

High Efficiency Air Filter

Disposable MERV 8 or MERV 13 (Minimum Efficiency Reporting Value based on ASHRAE 52.2) efficiency 2-inch pleated filters.

Replacement Filter Media Kit With Frame

Replaces existing pleated filter media. Includes washable metal mesh screen and metal frame with clip for holding replaceable non-pleated filter.

UVC Germicidal Lamps

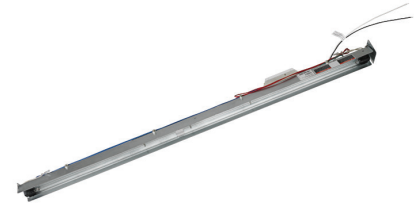

Germicidal lamps emit ultra-violet (UV-C) energy, which has been proven to be effective in reducing microbes such as viruses, bacteria, yeasts, and molds. This process either destroys the organism or controls its ability to reproduce.

UV-C energy greatly reduces the growth and proliferation of mold and other bioaerosols (bacteria and viruses) on illuminated surfaces (particularly coil and drain pan).

Lamps are field installed in the blower/evaporator coil section.

All necessary hardware for installation is included.

Lamps operate on 208/230V power supply. Step-down transformer must be field supplied when used with 460V and 575V rooftop units.

Magnetic safety interlock terminates power when access panels are removed.

Approved by ETL.

Indoor Air Quality (CO₂) Sensors

Monitors CO₂ levels, reports to the Unit Controller which adjusts economizer dampers as needed.

ECONOMIZER OPTIONS

Factory or Field Installed

10 Economizer Features (Standard and High Performance Common Features)

Downflow or Horizontal with Outdoor Air Hood and Barometric Relief Dampers with Exhaust Hood.

11 Barometric Relief Dampers allow relief of excess air, aluminum blade dampers prevent blow back and outdoor air infiltration during off cycle, bird screen furnished.

NOTE - Optional Horizontal Low Profile Barometric Relief Dampers with Exhaust Hood are available for field installation in a reduced space.

Occupied/Unoccupied mode with field furnished setback thermostat.

Demand Control Ventilation (DCV) ready using optional CO₂ sensors.

Mixed Air Sensor is furnished for field installation in the rooftop unit. Sensor is factory installed when Economizers are factory installed.

Single sensible sensor is furnished with Economizer and enables economizer operation if the outdoor temperature is less than the setpoint of the control.

Standard Economizer Features (Not for Title 24)

Gear-driven action, return air and outdoor air dampers, plug-in connections to unit, nylon bearings, neoprene seals, 24-volt, fully-modulating spring return motor.

Standard Economizer Control Module

The Standard Economizer Control Module can be adjusted to operate based on outdoor air temperatures.



Economizer Controls:

- Damper Minimum Position - Can be set lower than traditional minimum air requirements resulting in cost savings.
- IAQ Sensor - Signals dampers to modulate and maintain 55°F when CO₂ is higher than the CO₂ setpoint.
- Demand Control Ventilation (DCV) LED - A steady green Demand Control Ventilation LED indicates the IAQ reading is higher than setpoint and requires more fresh air.
- Free Cool LED - A steady green LED indicates outdoor air is suitable for free cooling.

Free Cooling runs when outdoor air temperature is lower than the set temperature on the economizer control.

NOTE: The Free Cooling default setting for outdoor air temperature sensor is 55°F.

High Performance Economizer Features

Approved for California Title 24 building standards.

Low leakage dampers are Air Movement and Control Association International (AMCA) Class 1A Certified - Maximum 3 CFM per sq. ft. leakage at 1 in. w.g.

ASHRAE 90.1-2010 compliant.

Gear-driven action, high torque 24-volt fully-modulating spring return damper motor, return air and outdoor air dampers, plug-in connections to unit, stainless steel bearings, enhanced neoprene blade edge seals and flexible stainless steel jamb seals to minimize air leakage.

NOTE - High Performance Economizers are not approved for use with enthalpy controls in Title 24 applications.

NOTE - The Free Cooling setpoint for Title 24 applications must be set based on the Climate Zone where the system is installed. See Section 140.4 "Prescriptive Requirements for Space Conditioning Systems" of the California Energy Commission's

2013 Building Energy Efficiency Standards.

Refer to Installation Instructions for complete setup information and menu parameters available.

High Performance Economizer Control Module

Module provides inputs and outputs to control economizer based on parameter settings. Module automatically detects sensors by polling to determine which sensors are installed in system.



Module displays any alarm messages (fault detection and diagnostics) as an aid in troubleshooting.

Non-volatile memory retains parameter settings in case of power failure.

Keypad with four navigation buttons and LCD screen is furnished for setting economizer parameters.

- Menu Up/Exit (↑) button returns to the main menu.
- Arrow Up (▲) button moves to the previous or next parameter within the selected menu.
- Arrow Down (▼) button moves to the next parameter within the selected menu.
- Select (enter) (↵) button confirms parameter selection.

Main Menu Structure:

- STATUS (economizer and system operation status)
- SETPOINTS (settings for various setpoint parameters)
- SYSTEM SETUP (settings/information about the system)
- ADVANCED SETUP (freeze protection, CO₂ settings, stage 3 delay and additional calibration settings)
- CHECKOUT (damper positions)
- ALARMS (output signal that can be configured for remote alarm monitoring)

ECONOMIZER **OPTIONS (continued)**

Factory or Field Installed

Single Enthalpy Temperature Control

(Not for Title 24)

Outdoor air enthalpy sensor enables economizer if the outdoor enthalpy is less than the setpoint of the control. Single enthalpy control is furnished with economizer.

Field Installed

Differential Enthalpy Control (Not for Title 24)

Order two Single Enthalpy Control Kits. One is field installed in the return air section, the other in the outdoor air section. Allows the economizer control board to select between outdoor air or return air, whichever has lower enthalpy.

EXHAUST OPTIONS

Field Installed

Horizontal Low Profile Barometric Relief Dampers

Replaces barometric relief dampers furnished with Economizer.

For use when unit is configured for horizontal applications in a reduced space requiring an economizer.

Allows relief of excess air.

Aluminum blade dampers prevent blow back and outdoor air infiltration during off cycle.

Field installed in return air duct.

Exhaust hood with bird screen furnished.

Requires Horizontal Discharge Kit.

Power Exhaust Fan

Installs internal to unit for downflow applications only with economizer option. Provides exhaust air pressure relief. Interlocked to run when supply air blower is operating, fan runs when outdoor air dampers are 50% open (adjustable), motor is overload protected. Requires Economizer with Outdoor Air Hood and Barometric Relief Dampers. Fan is 20 in. diameter with 5 blades (K1PWRE10B) WITH 1/3 hp motor.

OUTDOOR AIR OPTIONS

Factory or Field Installed

Outdoor Air Damper - Downflow or Horizontal With Air Hood

Linked mechanical dampers, 0 to 25% (fixed) outdoor air adjustable, installs in unit. Includes outdoor air hood.

Automatic model features fully modulating spring return damper motor with plug-in connection.

Manual model features a slide damper.

Maximum mixed air temperature in cooling mode: 100°F.

ROOF CURBS

Nailer strip furnished, mates to unit, U.S. National Roofing Contractors Approved, shipped knocked down.

Hybrid Roof Curbs, Downflow

Roof curb can be assembled using interlocking tabs to fasten corners together. No tools required.

Curb can also be fastened together with furnished hardware.

Available in 8, 14, 18, and 24 inch heights.

Adjustable Pitch Curb

Fully adjustable pitch curbs (3/4 in. per foot in any direction) provide a level platform for rooftop units allowing flexible installations on roofs with uneven or sloped angles.

Uses interlocking tabs to fasten corners together. No tools required.

Hardware is furnished to connect upper curb with lower curb.

Available in 14 inch height.

Adaptor Curbs (not shown)

Curbs are regionally sourced. Dimensions will vary based upon the source. Contact your local sales representative for a detailed cut sheet with applicable dimensions.

CEILING DIFFUSERS

Ceiling Diffusers (Flush or Step-Down)

Diffuser face and grilles with white powder coat finish, insulated (UL listed duct liner), diffuser box with collars for duct connection, fixed blades (flush diffusers) and double deflection blades (step-down diffusers), provisions for suspending, internally sealed (prevents recirculation), removable return air grille, adapts to T-bar ceiling grids or plaster ceilings.

Transitions (Supply and Return)

Used with diffusers, installs in roof curb, galvanized steel construction, flanges furnished for duct connection to diffusers, fully insulated.

OPTIONS / ACCESSORIES

Item Description	Model Number	Catalog Number	Unit Model No		
			KDB 092	KDB 102	KDB 122
COOLING/HEATING SYSTEM					
Condensate Drain Trap	PVC - C1TRAP20AD2	76W26	X	X	X
	Copper - C1TRAP10AD2	76W27	X	X	X
Corrosion Protection		Factory	O	O	O
Drain Pan Overflow Switch	K1SNSR71AB1-	74W42	X	X	X
Efficiency		High	O	O	O
Low Ambient Kit	K1SNSR34*B0	14N31	X	X	X
Refrigerant Type		R-410A	O	O	O
GAS HEATING SYSTEM					
Bottom Gas Piping Kit	C1GPKT01B-01	54W95	X	X	X
Combustion Air Intake Extensions	T1EXTN10AN1	19W51	X	X	X
Gas Heat Input	130,000 Btuh	Factory	O	O	O
	180,000 Btuh	Factory	O	O	O
	240,000 Btuh	Factory	O	O	O
Low Temperature Vestibule Heater	208/230V-3ph - C1LTVH10B-2Y	13X63	X	X	X
	460V - C1LTVH10B-2G	13X64	X	X	X
	575V - C1LTVH10B-2J	13X65	X	X	X
LPG/Propane Conversion Kits	Standard Heat - C1PROP23BS1	14N22	X	X	X
	Medium Heat - C1PROP22BS1	14N23	X	X	X
	High Heat - C1PROP21BS1	14N25	X	X	X
Vertical Vent Extension	C1EXTN2021	42W16	X	X	X
BLOWER - SUPPLY AIR					
Blower Option	CAV (Constant Air Volume)	Factory	O	O	
	Single Zone VAV Supply Fan	Factory	O	O	
	E-Direct™ (Direct Drive) Single Zone VAV Supply Fan	Factory			O
Blower Motors	Belt Drive - 2 hp	Factory	O	O	
	Belt Drive - 3 hp	Factory	O	O	
	Belt Drive - 5 hp	Factory	O	O	
VFD Manual Bypass Kit (for Single Zone VAV Supply Fan equipped units only)	KVFDB12C-1	90W53	X	X	
Drive Kits	Kit #1 590-890 rpm	Factory	O	O	
See Blower Data Tables for selection	Kit #2 800-1105 rpm	Factory	O	O	
	Kit #3 795-1195 rpm	Factory	O	O	
	Kit #4 730-970 rpm	Factory	O	O	
	Kit #5 940-1200 rpm	Factory	O	O	
	Kit #6 1015-1300 rpm	Factory	O	O	
	Kit #10 900-1135 rpm	Factory	O	O	
	Kit #11 1040-1315 rpm	Factory	O	O	
	Kit #12 1125-1425 rpm	Factory	O	O	

NOTE - Catalog and model numbers shown are for ordering field installed accessories.

OX - Configure To Order (Factory Installed) or Field Installed

O = Configure To Order (Factory Installed)

X = Field Installed

OPTIONS / ACCESSORIES

Item Description	Model Number	Catalog Number	Unit Model No		
			KDB 092	KDB 102	KDB 122
CABINET					
Combination Coil/Hail Guards	High Efficiency - K1GARD53B-1	14Y77	X	X	
	High Efficiency - E1GARD51BP1	13T06			X
Hinged Access Panels		Factory	O	O	O
Horizontal Discharge Kit	K1HECK00B-1	51W25	X	X	X
Return Air Adaptor Plate (for LC/LG/LH and TC/TG/TH unit replacement)	C1CONV10B-1	54W96	X	X	X
CONTROLS					
NOTE - Also see Conventional Thermostat Control Systems on page 27 for Additional Options.					
Commercial Controls					
Smoke Detector - Supply or Return (Power board and one sensor)	C1SNSR44B-2	11K76	X	X	X
Smoke Detector - Supply and Return (Power board and two sensors)	C1SNSR43B-2	11K80	X	X	X
INDOOR AIR QUALITY					
High Efficiency Air Filters 20 x 25 x 2 (Order 4 per unit)	MERV 8 - C1FLTR15B-1	50W61	X	X	X
	MERV 13 - C1FLTR40B-1	52W41	X	X	X
Replacement Media Filter With Metal Mesh Frame (includes non-pleated filter media)	C1FLTR30B-1-	Y3063	X	X	X
Indoor Air Quality (CO₂) Sensors					
Sensor - Wall-mount, off-white plastic cover with LCD display	C0SNSR50AE1L	77N39	X	X	X
Sensor - Wall-mount, off-white plastic cover, no display	C0SNSR52AE1L	87N53	X	X	X
Sensor - Black plastic case with LCD display, rated for plenum mounting	C0SNSR51AE1L	87N52	X	X	X
Sensor - Wall-mount, black plastic case, no display, rated for plenum mounting	C0MISC19AE1	87N54	X	X	X
CO ₂ Sensor Duct Mounting Kit - for downflow applications	C0MISC19AE1-	85L43	X	X	X
Aspiration Box - for duct mounting non-plenum rated CO ₂ sensors (87N53 or 77N39)	C0MISC16AE1-	90N43	X	X	X
UVC Germicidal Lamps					
¹ UVC Light Kit (208/230v-1ph)	C1UVCL10B-1	54W62	X	X	X
ELECTRICAL					
Voltage 60 hz	208/230V - 3 phase	Factory	O	O	O
	460V - 3 phase	Factory	O	O	O
	575V - 3 phase	Factory	O	O	O
Disconnect Switch	80 amp - C1DISC080B-1	54W56	OX	OX	OX
GFI Service Outlets	15 amp non-powered, field-wired (208/230V, 460V only)	LTAGFIK10/15	74M70	OX	OX
	20 amp non-powered, field-wired (575V only)	C1GFIC120FF1	67E01	X	X
Weatherproof Cover for GFI	C1GFIC199FF1	10C89	X	X	X

NOTE - Catalog and model numbers shown are for ordering field installed accessories.

OX - Configure To Order (Factory Installed) or Field Installed

O = Configure To Order (Factory Installed)

X = Field Installed

OPTIONS / ACCESSORIES

Item Description	Model Number	Catalog Number	Unit Model No		
			KDB 092	KDB 102	KDB 122
ECONOMIZER					
Standard Economizer (Not for Title 24)					
Standard Economizer with Single Temperature Control Downflow or Horizontal Applications - Includes Barometric Relief Dampers and Air Hoods	K1ECON20B-2	13U45	OX	OX	OX
Standard Economizer Controls (Not for Title 24)					
Single Enthalpy Control	C1SNSR64FF1	53W64	OX	OX	OX
Differential Enthalpy Control (order 2)	C1SNSR64FF1	53W64	X	X	X
High Performance Economizer (Approved for California Title 24 Building Standards / AMCA Class 1A Certified)					
High Performance Economizer with Single Temperature Control Downflow or Horizontal Applications - Includes Barometric Relief Dampers and Air Hoods	K1ECON22B-3	17U09	OX	OX	OX
High Performance Economizer Controls (Not for Title 24)					
Single Enthalpy Control	C1SNSR60FF1	10Z75	OX	OX	OX
Differential Enthalpy Control (order 2)	C1SNSR60FF1	10Z75	X	X	X
Horizontal Low Profile Barometric Relief Dampers With Exhaust Hood					
Horizontal Low Profile Barometric Relief Dampers With Exhaust Hood	LAGEDH03/15	53K04	X	X	X
OUTDOOR AIR					
Outdoor Air Dampers with Outdoor Air Hood					
Motorized	C1DAMP20B-1	14G28	OX	OX	OX
Manual	C1DAMP10B-2	14G29	OX	OX	OX
POWER EXHAUST					
Standard Static	208/230V-3ph - K1PWRE10B-1Y	53W44	X	X	X
	460V-3ph - K1PWRE10B-1G	53W45	X	X	X
	575V-3ph - K1PWRE10B-1J	53W46	X	X	X
ROOF CURBS					
Hybrid Roof Curbs, Downflow					
8 in. height	C1CURB70B-1	11F54	X	X	X
14 in. height	C1CURB71B-1	11F55	X	X	X
18 in. height	C1CURB72B-1	11F56	X	X	X
24 in. height	C1CURB73B-1	11F57	X	X	X
Adjustable Pitch Curb, Downflow					
14 in. height	C1CURB55B-1	54W50	X	X	X
CEILING DIFFUSERS					
Step-Down - Order one	RTD11-95S	13K61	X		
	RTD11-135S	13K62		X	X
Flush - Order one	FD11-95S	13K56	X		
	FD11-135S	13K57		X	X
Transitions (Supply and Return) - Order one	C1DIFF30B-1	12X65	X		
	C1DIFF31B-1	12X66		X	X

NOTE - Catalog and model numbers shown are for ordering field installed accessories.

OX - Configure To Order (Factory Installed) or Field Installed

O = Configure To Order (Factory Installed)

X = Field Installed

SPECIFICATIONS

General Data		Nominal Tonnage	7.5 Ton	7.5 Ton	8.5 Ton	8.5 Ton	10 Ton
		Model Number	KDB092H4B	KDB092H4M	KDB102H4B	KDB102H4M	KDB122H4E
		Efficiency Type	High	High	High	High	High
		Blower Type	CAV (Constant Air Volume)	Single Zone VAV Supply Fan	CAV (Constant Air Volume)	Single Zone VAV Supply Fan	Single Zone VAV Supply Fan E-Direct™ (Direct Drive)
Cooling Performance	Gross Cooling Capacity - Btuh		91,600	91,600	103,400	103,400	121,000
	¹ Net Cooling Capacity - Btuh		89,000	89,000	100,000	100,000	118,000
	AHRI Rated Air Flow - cfm		3,000	3,000	3,400	3,400	3600
	Total Unit Power - kW		7.3	7.3	8.3	8.3	9.6
	¹ EER (Btuh/Watt)		12.1	12.1	12.0	12.0	12.3
	¹ IEER (Btuh/Watt)		12.9	14.2	12.5	14.3	14.8
	Refrigerant Type		R-410A	R-410A	R-410A	R-410A	R-410A
	Refrigerant Charge	Circuit 1	13 lbs. 8 oz.	13 lbs. 8 oz.	13 lbs. 8 oz.	13 lbs. 8 oz.	19 lbs. 8 oz.
	Circuit 2	13 lbs. 8 oz.	13 lbs. 8 oz.	13 lbs. 0 oz.	13 lbs. 0 oz.	20 lbs. 8 oz.	
Heating Performance	¹ Total High Heat Capacity - Btuh		86,000	86,000	100,000	100,000	116,000
	Total Unit Power - kW		7.0	7.0	8.1	8.1	9.5
	¹ C.O.P.		3.60	3.60	3.60	3.60	3.60
	¹ Total Low Heat Capacity - Btuh		51,000	51,000	55,000	56,000	65,000
	Total Unit Power (kW)		6.6	6.6	7.3	7.3	8.5
	¹ C.O.P.		2.25	2.25	2.25	2.25	2.25
Gas Heating Options Available - See page 14			Standard (2 stage), Medium (2 Stage), High (2 Stage)				
Compressor Type (number)			Scroll (2)	Scroll (2)	Scroll (2)	Scroll (2)	Scroll (2)
Outdoor Coils	Net face area (total) - sq. ft.		25.9	25.9	25.9	25.9	40.4
	Tube diameter - in.		3/8	3/8	3/8	3/8	3/8
	Number of rows		3	3	3	3	3
	Fins per inch		20	20	20	20	20
Outdoor Coil Fans	Motor - (No.) horsepower		(2) 1/3 ECM	(2) 1/3 ECM	(2) 1/3 ECM	(2) 1/3 ECM	(3) 1/3 ECM
	Motor rpm		530-950	530-950	650-1010	650-1010	530-950
	Total Motor watts		140-620	140-620	220-700	220-700	180-800
	Diameter - (No.) in.		(2) 24	(2) 24	(2) 24	(2) 24	(3) 24
	Number of blades		3	3	3	3	3
	Total Air volume - cfm		3600-7000	3600-7000	4600-7500	4600-7500	5500-10,600
Indoor Coils	Net face area (total) - sq. ft.		12.8	12.8	12.8	12.8	12.8
	Tube diameter - in.		3/8	3/8	3/8	3/8	3/8
	Number of rows		4	4	4	4	4
	Fins per inch		14	14	14	14	14
Drain connection - Number and size			(1) 1 in. NPT coupling				
Expansion device type			Balance port TXV, removable head				
² Indoor Blower and Drive Selection	Nominal motor output		2 hp, 3 hp, 5 hp				3.75 hp (ECM)
	Maximum usable motor output (US Only)		2.3 hp, 3.45 hp, 5.75 hp				---
	Motor - Drive kit number		2 hp ³ Kit 1 590-890 rpm Kit 2 800-1105 rpm Kit 3 795-1195 rpm		3 hp Kit 4 730-970 rpm Kit 5 940-1200 rpm Kit 6 1015-1300 rpm		---
			5 hp Kit 10 900-1135 rpm Kit 11 1040-1315 rpm Kit 12 1125-1425 rpm				
Blower wheel nominal diameter x width - in.			(1) 15 X 15	(1) 15 X 15	(1) 15 X 15	(1) 15 X 15	(1) 22 x 19
Filters	Type of filter		Disposable				
	Number and size - in.		(4) 20 x 25 x 2				
Electrical characteristics			208/230V, 460V or 575V - 60 hertz - 3 phase				

NOTE - Net capacity includes evaporator blower motor heat deduction. Gross capacity does not include evaporator blower motor heat deduction.

¹ AHRI Certified to AHRI Standard 340/360:

Cooling Ratings - 95°F outdoor air temperature and 80°F db/67°F wb entering indoor coil air.

High Temperature Heating Ratings - 47°F db/43°F wb outdoor air temperature and 70°F entering indoor coil air.

Low Temperature Heating Ratings - 17°F db/15°F wb outdoor air temperature and 70°F entering indoor coil air.

² Using total air volume and system static pressure requirements determine from blower performance tables rpm and motor output required. Maximum usable output of motors furnished are shown. In Canada, nominal motor output is also maximum usable motor output. If motors of comparable output are used, be sure to keep within the service factor limitations outlined on the motor nameplate.

⁴ Standard motor and drive kit furnished with unit.

NOTE – Units equipped with Single Zone VAV Supply Fan option are limited to a motor service factor of 1.0.

SPECIFICATIONS - GAS HEAT

		Heat Input Type	Standard	Medium	High
		Number of Gas Heat Stages	2	2	2
Gas Heating Performance	Input - Btuh	First Stage	84,500	117,000	156,000
		Second Stage	130,000	180,000	240,000
		Output - Btuh	104,000	144,000	192,000
		Temperature Rise Range - °F	15-45	30-60	40-70
		Thermal Efficiency	80%	80%	80%
		Gas Supply Connections	3/4 in NPT	3/4 in NPT	3/4 in NPT
Recommended Gas Supply Pressure - in. w.g.	Natural		7	7	7
	LPG/Propane		11	11	11

HIGH ALTITUDE DERATE

Units may be installed at altitudes up to 2000 feet above sea level without any modification.

At altitudes above 2000 feet, units must be derated to match gas manifold pressures shown in table below.

At altitudes above 4500 feet unit must be derated 2% for each 1000 feet above sea level.

NOTE – This is the only permissible derate for these units.

Gas Heat Type	Altitude	Gas Manifold Pressure		Input Rate Natural Gas or LPG/Propane	
		Natural Gas	LPG/Propane Gas	First Stage	Second Stage
	ft.	In. w.g.	In. w.g.	Btuh	Btuh
Standard	2001-4500	3.4	9.6	84,500	124,000
Medium	2001-4500	3.4	9.6	117,000	172,000
High	2001-4500	3.4	9.6	156,000	230,000

COOLING/HEATING RATINGS

NOTE – For Temperatures and Capacities not shown in tables, see bulletin – Cooling Unit Rating Table Correction Factor Data in Miscellaneous Engineering Data section.

7.5 TON COOLING HIGH EFFICIENCY KDB092H4 (1ST STAGE) - CONSTANT AIR VOLUME

Entering Wet Bulb Temperature	Total Air Volume	Outdoor Air Temperature Entering Outdoor Coil																			
		65°F					75°F					85°F					95°F				
		Total Cool Cap.	Comp. Motor Input	Sensible To Total Ratio (S/T) Dry Bulb			Total Cool Cap.	Comp. Motor Input	Sensible To Total Ratio (S/T) Dry Bulb			Total Cool Cap.	Comp. Motor Input	Sensible To Total Ratio (S/T) Dry Bulb			Total Cool Cap.	Comp. Motor Input	Sensible To Total Ratio (S/T) Dry Bulb		
				75°F	80°F	85°F			75°F	80°F	85°F			75°F	80°F	85°F			75°F	80°F	85°F
		cfm	kBtuh	kW	75°F	80°F	85°F	kBtuh	kW	75°F	80°F	85°F	kBtuh	kW	75°F	80°F	85°F	kBtuh	kW	75°F	80°F
63°F	2400	49.0	2.33	0.62	0.78	0.97	43.8	2.62	0.62	0.80	1.00	38.4	2.94	0.61	0.82	1.00	32.9	3.31	0.60	0.85	1.00
	3000	52.7	2.35	0.68	0.90	1.00	47.2	2.64	0.69	0.93	1.00	41.8	2.96	0.69	0.96	1.00	36.1	3.33	0.70	1.00	1.00
	3600	55.5	2.37	0.76	0.99	1.00	50.2	2.66	0.77	1.00	1.00	45.0	2.99	0.79	1.00	1.00	39.8	3.36	0.82	1.00	1.00
67°F	2400	53.8	2.36	0.48	0.60	0.74	48.4	2.65	0.47	0.60	0.76	42.9	2.97	0.44	0.60	0.77	37.2	3.34	0.42	0.59	0.80
	3000	57.3	2.38	0.53	0.67	0.85	51.8	2.67	0.51	0.67	0.88	45.9	2.99	0.50	0.68	0.92	39.9	3.36	0.48	0.69	0.96
	3600	59.9	2.40	0.56	0.74	0.95	54.2	2.68	0.55	0.75	0.98	48.1	3.01	0.55	0.77	1.00	42.0	3.38	0.53	0.80	1.00
71°F	2400	58.5	2.39	0.36	0.48	0.59	53.1	2.67	0.34	0.47	0.59	47.4	3.00	0.31	0.45	0.59	41.6	3.37	0.27	0.42	0.58
	3000	62.2	2.41	0.38	0.52	0.65	56.4	2.70	0.37	0.51	0.66	50.5	3.02	0.34	0.50	0.66	44.4	3.39	0.30	0.49	0.67
	3600	64.7	2.43	0.41	0.56	0.72	58.8	2.71	0.39	0.55	0.73	52.8	3.04	0.37	0.55	0.75	46.3	3.41	0.33	0.54	0.77

7.5 TON COOLING HIGH EFFICIENCY KDB092H4 (2ND STAGE) - CONSTANT AIR VOLUME

Entering Wet Bulb Temperature	Total Air Volume	Outdoor Air Temperature Entering Outdoor Coil																			
		85°F					95°F					105°F					115°F				
		Total Cool Cap.	Comp. Motor Input	Sensible To Total Ratio (S/T) Dry Bulb			Total Cool Cap.	Comp. Motor Input	Sensible To Total Ratio (S/T) Dry Bulb			Total Cool Cap.	Comp. Motor Input	Sensible To Total Ratio (S/T) Dry Bulb			Total Cool Cap.	Comp. Motor Input	Sensible To Total Ratio (S/T) Dry Bulb		
				75°F	80°F	85°F			75°F	80°F	85°F			75°F	80°F	85°F			75°F	80°F	85°F
		cfm	kBtuh	kW	75°F	80°F	85°F	kBtuh	kW	75°F	80°F	85°F	kBtuh	kW	75°F	80°F	85°F	kBtuh	kW	75°F	80°F
63°F	2400	89.0	5.20	0.69	0.84	0.99	81.7	5.90	0.69	0.86	1.00	74.1	6.69	0.70	0.89	1.00	66.1	7.63	0.72	0.94	1.00
	3000	94.7	5.21	0.75	0.94	1.00	87.0	5.90	0.76	0.97	1.00	79.0	6.69	0.78	1.00	1.00	71.5	7.62	0.82	1.00	1.00
	3600	99.1	5.23	0.81	1.00	1.00	92.1	5.90	0.83	1.00	1.00	84.7	6.71	0.87	1.00	1.00	76.8	7.63	0.91	1.00	1.00
67°F	2400	96.6	5.22	0.53	0.66	0.80	88.8	5.90	0.52	0.67	0.83	80.8	6.70	0.52	0.68	0.85	72.4	7.63	0.52	0.70	0.89
	3000	101.9	5.23	0.57	0.73	0.90	93.7	5.91	0.57	0.74	0.93	85.4	6.70	0.57	0.76	0.96	76.4	7.64	0.57	0.79	1.00
	3600	105.8	5.24	0.60	0.79	0.98	97.3	5.91	0.61	0.81	1.00	88.6	6.71	0.62	0.84	1.00	79.4	7.62	0.63	0.88	1.00
71°F	2400	103.6	5.24	0.39	0.51	0.64	95.8	5.92	0.38	0.52	0.65	87.6	6.70	0.36	0.51	0.66	78.9	7.63	0.34	0.51	0.68
	3000	109.5	5.25	0.41	0.56	0.71	101.3	5.93	0.40	0.56	0.72	92.3	6.71	0.39	0.57	0.74	83.2	7.64	0.37	0.57	0.76
	3600	113.4	5.26	0.43	0.60	0.77	104.9	5.94	0.41	0.60	0.79	95.8	6.72	0.41	0.62	0.82	85.9	7.64	0.40	0.62	0.86

7.5 TON HEATING HIGH EFFICIENCY KDB092H4 - CONSTANT AIR VOLUME

Indoor Coil Air Volume 70°F Dry Bulb cfm	Air Temperature Entering Outdoor Coil									
	65°F		45°F		25°F		5°F		-15°F	
	Total Heating Capacity	Comp. Motor Input	Total Heating Capacity	Comp. Motor Input	Total Heating Capacity	Comp. Motor Input	Total Heating Capacity	Comp. Motor Input	Total Heating Capacity	Comp. Motor Input
	kBtuh	kW	kBtuh	kW	kBtuh	kW	kBtuh	kW	kBtuh	kW
2400	113.5	5.44	86.6	5.53	59.9	5.65	34.9	5.24	17.5	3.84
3000	115.5	5.07	88.6	5.17	61.9	5.28	36.9	4.88	19.5	3.48
3600	117.3	4.85	90.5	4.94	63.7	5.06	38.7	4.65	21.4	3.25

COOLING/HEATING RATINGS

NOTE – For Temperatures and Capacities not shown in tables, see bulletin – Cooling Unit Rating Table Correction Factor Data in Miscellaneous Engineering Data section.

8.5 TON COOLING HIGH EFFICIENCY KDB102H4 (1ST STAGE) - CONSTANT AIR VOLUME

Entering Wet Bulb Temperature	Total Air Volume	Outdoor Air Temperature Entering Outdoor Coil																			
		65°F					75°F					85°F					95°F				
		Total Cool Cap.	Comp. Motor Input	Sensible To Total Ratio (S/T) Dry Bulb			Total Cool Cap.	Comp. Motor Input	Sensible To Total Ratio (S/T) Dry Bulb			Total Cool Cap.	Comp. Motor Input	Sensible To Total Ratio (S/T) Dry Bulb			Total Cool Cap.	Comp. Motor Input	Sensible To Total Ratio (S/T) Dry Bulb		
				75°F	80°F	85°F			75°F	80°F	85°F			75°F	80°F	85°F			75°F	80°F	85°F
cfm	kBtuh	kW	75°F	80°F	85°F	kBtuh	kW	75°F	80°F	85°F	kBtuh	kW	75°F	80°F	85°F	kBtuh	kW	75°F	80°F	85°F	
63°F	2720	56.5	2.64	0.63	0.79	0.97	50.8	3.00	0.62	0.80	0.99	45.1	3.40	0.62	0.82	1.00	39.2	3.84	0.61	0.85	1.00
	3400	60.6	2.66	0.68	0.89	1.00	54.8	3.03	0.69	0.92	1.00	48.8	3.43	0.70	0.96	1.00	42.8	3.87	0.71	0.99	1.00
	4080	63.8	2.69	0.76	0.99	1.00	58.0	3.05	0.77	1.00	1.00	52.5	3.46	0.79	1.00	1.00	46.7	3.90	0.81	1.00	1.00
67°F	2720	61.8	2.67	0.49	0.61	0.75	56.2	3.04	0.47	0.61	0.76	50.3	3.43	0.45	0.60	0.78	44.0	3.88	0.43	0.60	0.80
	3400	65.8	2.69	0.53	0.67	0.85	59.9	3.06	0.52	0.67	0.88	53.7	3.46	0.51	0.68	0.91	47.2	3.90	0.49	0.69	0.95
	4080	68.8	2.72	0.57	0.74	0.95	62.6	3.08	0.56	0.75	0.98	56.1	3.48	0.55	0.77	1.00	49.6	3.92	0.55	0.79	1.00
71°F	2720	67.3	2.70	0.37	0.48	0.60	61.4	3.07	0.35	0.47	0.59	55.4	3.47	0.32	0.46	0.59	48.9	3.91	0.28	0.43	0.59
	3400	71.3	2.73	0.39	0.52	0.65	65.2	3.10	0.37	0.52	0.66	58.9	3.50	0.35	0.51	0.66	52.2	3.95	0.31	0.49	0.67
	4080	74.3	2.75	0.41	0.56	0.72	67.9	3.12	0.39	0.56	0.73	61.3	3.52	0.37	0.55	0.75	54.6	3.97	0.34	0.55	0.77

8.5 TON COOLING HIGH EFFICIENCY KDB102H4 (2ND STAGE) - CONSTANT AIR VOLUME

Entering Wet Bulb Temperature	Total Air Volume	Outdoor Air Temperature Entering Outdoor Coil																			
		85°F					95°F					105°F					115°F				
		Total Cool Cap.	Comp. Motor Input	Sensible To Total Ratio (S/T) Dry Bulb			Total Cool Cap.	Comp. Motor Input	Sensible To Total Ratio (S/T) Dry Bulb			Total Cool Cap.	Comp. Motor Input	Sensible To Total Ratio (S/T) Dry Bulb			Total Cool Cap.	Comp. Motor Input	Sensible To Total Ratio (S/T) Dry Bulb		
				75°F	80°F	85°F			75°F	80°F	85°F			75°F	80°F	85°F			75°F	80°F	85°F
cfm	kBtuh	kW	75°F	80°F	85°F	kBtuh	kW	75°F	80°F	85°F	kBtuh	kW	75°F	80°F	85°F	kBtuh	kW	75°F	80°F	85°F	
63°F	2720	100.8	5.51	0.66	0.83	1.00	93.3	6.23	0.67	0.85	1.00	85.4	7.06	0.68	0.89	1.00	76.9	8.02	0.70	0.94	1.00
	3400	106.8	5.53	0.72	0.94	1.00	98.8	6.24	0.74	0.97	1.00	90.7	7.07	0.77	1.00	1.00	82.9	8.03	0.80	1.00	1.00
	4080	111.8	5.54	0.79	1.00	1.00	104.3	6.25	0.82	1.00	1.00	96.6	7.08	0.86	1.00	1.00	88.3	8.03	0.91	1.00	1.00
67°F	2720	108.7	5.53	0.51	0.64	0.78	100.7	6.25	0.51	0.65	0.81	92.3	7.06	0.51	0.66	0.84	83.5	8.03	0.51	0.68	0.89
	3400	114.1	5.55	0.55	0.70	0.89	106.0	6.26	0.55	0.71	0.93	97.1	7.08	0.56	0.74	0.97	87.5	8.04	0.56	0.77	1.00
	4080	118.3	5.56	0.58	0.77	0.98	109.7	6.27	0.59	0.79	1.00	100.4	7.09	0.60	0.83	1.00	90.8	8.03	0.61	0.88	1.00
71°F	2720	116.4	5.55	0.38	0.50	0.61	108.1	6.26	0.37	0.50	0.63	99.5	7.08	0.36	0.50	0.64	90.4	8.04	0.35	0.51	0.66
	3400	122.1	5.57	0.40	0.54	0.68	113.5	6.28	0.39	0.54	0.69	104.4	7.10	0.38	0.55	0.71	94.7	8.04	0.37	0.56	0.75
	4080	126.4	5.58	0.41	0.58	0.74	117.4	6.29	0.41	0.58	0.77	108.0	7.10	0.41	0.60	0.81	97.6	8.05	0.40	0.61	0.85

8.5 TON HEATING HIGH EFFICIENCY KDB102H4 - CONSTANT AIR VOLUME

Indoor Coil Air Volume 70°F Dry Bulb cfm	Air Temperature Entering Outdoor Coil									
	65°F		45°F		25°F		5°F		-15°F	
	Total Heating Capacity	Comp. Motor Input	Total Heating Capacity	Comp. Motor Input	Total Heating Capacity	Comp. Motor Input	Total Heating Capacity	Comp. Motor Input	Total Heating Capacity	Comp. Motor Input
	kBtuh	kW	kBtuh	kW	kBtuh	kW	kBtuh	kW	kBtuh	kW
2720	128.8	6.27	99.5	6.41	71.5	6.63	38.5	5.92	19.5	4.34
3400	131.0	5.86	101.7	6.00	73.7	6.21	40.7	5.51	21.7	3.93
4080	132.8	5.60	103.6	5.74	75.5	5.95	42.5	5.25	23.5	3.67

COOLING/HEATING RATINGS

NOTE – For Temperatures and Capacities not shown in tables, see bulletin – Cooling Unit Rating Table Correction Factor Data in Miscellaneous Engineering Data section.

7.5 TON COOLING HIGH EFFICIENCY KDB092H4 (1ST STAGE) - SINGLE ZONE VAV SUPPLY FAN SUPPLY AIR BLOWER

Entering Wet Bulb Temperature	Total Air Volume	Outdoor Air Temperature Entering Outdoor Coil																			
		65°F					75°F					85°F					95°F				
		Total Cool Cap.	Comp. Motor Input	Sensible To Total Ratio (S/T) Dry Bulb			Total Cool Cap.	Comp. Motor Input	Sensible To Total Ratio (S/T) Dry Bulb			Total Cool Cap.	Comp. Motor Input	Sensible To Total Ratio (S/T) Dry Bulb			Total Cool Cap.	Comp. Motor Input	Sensible To Total Ratio (S/T) Dry Bulb		
				75°F	80°F	85°F			75°F	80°F	85°F			75°F	80°F	85°F			75°F	80°F	85°F
cfm	kBtuh	kW	75°F	80°F	85°F	kBtuh	kW	75°F	80°F	85°F	kBtuh	kW	75°F	80°F	85°F	kBtuh	kW	75°F	80°F	85°F	
63°F	1680	43.4	2.26	0.61	0.72	0.85	39.9	2.54	0.60	0.73	0.86	36.2	2.87	0.59	0.73	0.88	32.3	3.24	0.58	0.74	0.90
	2100	47.1	2.29	0.65	0.79	0.93	43.2	2.57	0.65	0.80	0.95	39.2	2.89	0.65	0.81	0.97	35.1	3.26	0.65	0.83	1.00
	2520	49.8	2.31	0.69	0.85	0.99	45.8	2.59	0.70	0.87	1.00	41.6	2.91	0.70	0.89	1.00	37.4	3.28	0.71	0.92	1.00
67°F	1680	47.2	2.29	0.49	0.59	0.69	43.6	2.57	0.47	0.58	0.69	39.7	2.89	0.45	0.57	0.70	35.7	3.26	0.43	0.57	0.71
	2100	51.0	2.31	0.51	0.63	0.76	47.1	2.60	0.50	0.63	0.76	42.8	2.92	0.49	0.63	0.78	38.7	3.29	0.48	0.63	0.79
	2520	53.8	2.34	0.54	0.67	0.81	49.6	2.62	0.53	0.68	0.83	45.2	2.94	0.52	0.68	0.85	40.7	3.31	0.51	0.70	0.88
71°F	1680	51.2	2.31	0.38	0.48	0.57	47.4	2.60	0.36	0.46	0.56	43.3	2.92	0.34	0.45	0.55	39.2	3.29	0.31	0.43	0.55
	2100	55.0	2.34	0.39	0.50	0.61	50.8	2.63	0.37	0.49	0.61	46.6	2.95	0.36	0.48	0.61	42.2	3.32	0.33	0.47	0.61
	2520	57.7	2.36	0.41	0.53	0.65	53.5	2.65	0.40	0.53	0.66	48.9	2.97	0.37	0.52	0.66	44.3	3.34	0.35	0.51	0.67

7.5 TON COOLING HIGH EFFICIENCY KDB092H4 (2ND STAGE) - SINGLE ZONE VAV SUPPLY FAN SUPPLY AIR BLOWER

Entering Wet Bulb Temperature	Total Air Volume	Outdoor Air Temperature Entering Outdoor Coil																			
		85°F					95°F					105°F					115°F				
		Total Cool Cap.	Comp. Motor Input	Sensible To Total Ratio (S/T) Dry Bulb			Total Cool Cap.	Comp. Motor Input	Sensible To Total Ratio (S/T) Dry Bulb			Total Cool Cap.	Comp. Motor Input	Sensible To Total Ratio (S/T) Dry Bulb			Total Cool Cap.	Comp. Motor Input	Sensible To Total Ratio (S/T) Dry Bulb		
				75°F	80°F	85°F			75°F	80°F	85°F			75°F	80°F	85°F			75°F	80°F	85°F
cfm	kBtuh	kW	75°F	80°F	85°F	kBtuh	kW	75°F	80°F	85°F	kBtuh	kW	75°F	80°F	85°F	kBtuh	kW	75°F	80°F	85°F	
63°F	2400	87.5	5.26	0.68	0.84	0.99	80.2	5.96	0.69	0.86	1.00	72.8	6.76	0.70	0.89	1.00	64.8	7.72	0.72	0.94	1.00
	3000	93.1	5.27	0.75	0.94	1.00	85.5	5.96	0.76	0.97	1.00	77.6	6.76	0.78	1.00	1.00	70.2	7.71	0.81	1.00	1.00
	3600	97.4	5.28	0.81	1.00	1.00	90.5	5.97	0.83	1.00	1.00	83.2	6.78	0.87	1.00	1.00	75.4	7.71	0.91	1.00	1.00
67°F	2400	94.8	5.27	0.52	0.66	0.80	87.2	5.96	0.52	0.67	0.82	79.3	6.77	0.52	0.68	0.85	71.0	7.71	0.51	0.70	0.89
	3000	100.2	5.29	0.57	0.73	0.90	92.1	5.97	0.57	0.74	0.93	83.9	6.78	0.57	0.76	0.96	75.0	7.72	0.57	0.79	1.00
	3600	104.0	5.30	0.60	0.79	0.98	95.7	5.98	0.61	0.81	1.00	87.0	6.78	0.61	0.84	1.00	77.9	7.70	0.63	0.88	1.00
71°F	2400	101.9	5.29	0.38	0.51	0.64	94.1	5.98	0.37	0.52	0.65	86.0	6.77	0.36	0.51	0.66	77.5	7.72	0.34	0.51	0.68
	3000	107.6	5.30	0.41	0.56	0.71	99.5	5.99	0.40	0.56	0.72	90.6	6.79	0.39	0.56	0.74	81.7	7.72	0.37	0.57	0.76
	3600	111.5	5.32	0.43	0.59	0.77	103.1	6.00	0.41	0.60	0.79	94.1	6.79	0.41	0.62	0.82	84.4	7.72	0.40	0.62	0.86

7.5 TON HEATING HIGH EFFICIENCY KDB092H4 - SINGLE ZONE VAV SUPPLY FAN SUPPLY AIR BLOWER

Indoor Coil Air Volume 70°F Dry Bulb cfm	Air Temperature Entering Outdoor Coil									
	65°F		45°F		25°F		5°F		-15°F	
	Total Heating Capacity	Comp. Motor Input	Total Heating Capacity	Comp. Motor Input	Total Heating Capacity	Comp. Motor Input	Total Heating Capacity	Comp. Motor Input	Total Heating Capacity	Comp. Motor Input
2400	109.5	5.49	82.8	5.53	56.6	5.56	31.0	5.28	15.7	3.87
3000	111.5	5.12	84.8	5.16	58.5	5.19	33.0	4.91	17.7	3.50
3600	113.1	4.89	86.5	4.93	60.2	4.96	34.6	4.68	19.3	3.27

COOLING/HEATING RATINGS

NOTE – For Temperatures and Capacities not shown in tables, see bulletin – Cooling Unit Rating Table Correction Factor Data in Miscellaneous Engineering Data section.

8.5 TON COOLING HIGH EFFICIENCY KDB102H4 (1ST STAGE) - SINGLE ZONE VAV SUPPLY FAN SUPPLY AIR BLOWER

Entering Wet Bulb Temperature	Total Air Volume	Outdoor Air Temperature Entering Outdoor Coil																			
		65°F					75°F					85°F					95°F				
		Total Cool Cap.	Comp. Motor Input	Sensible To Total Ratio (S/T) Dry Bulb			Total Cool Cap.	Comp. Motor Input	Sensible To Total Ratio (S/T) Dry Bulb			Total Cool Cap.	Comp. Motor Input	Sensible To Total Ratio (S/T) Dry Bulb			Total Cool Cap.	Comp. Motor Input	Sensible To Total Ratio (S/T) Dry Bulb		
				75°F	80°F	85°F			75°F	80°F	85°F			75°F	80°F	85°F			75°F	80°F	85°F
cfm	kBtuh	kW	75°F	80°F	85°F	kBtuh	kW	75°F	80°F	85°F	kBtuh	kW	75°F	80°F	85°F	kBtuh	kW	75°F	80°F	85°F	
63°F	1920	50.7	2.57	0.61	0.72	0.85	47.4	2.92	0.61	0.73	0.86	43.9	3.31	0.60	0.73	0.88	40.3	3.74	0.60	0.75	0.90
	2400	54.5	2.59	0.64	0.79	0.93	51.0	2.95	0.65	0.79	0.95	47.2	3.34	0.65	0.81	0.97	43.3	3.78	0.66	0.83	1.00
	2880	57.2	2.61	0.68	0.84	0.99	53.6	2.98	0.69	0.86	1.00	49.6	3.37	0.70	0.89	1.00	45.5	3.80	0.71	0.92	1.00
67°F	1920	54.6	2.59	0.49	0.59	0.69	51.2	2.95	0.48	0.59	0.69	47.6	3.34	0.47	0.58	0.70	43.9	3.78	0.46	0.58	0.71
	2400	58.6	2.62	0.51	0.62	0.75	54.9	2.98	0.51	0.63	0.76	51.0	3.38	0.50	0.63	0.77	47.0	3.82	0.50	0.64	0.79
	2880	61.3	2.65	0.53	0.66	0.81	57.6	3.01	0.53	0.67	0.83	53.6	3.40	0.53	0.68	0.85	49.1	3.84	0.53	0.69	0.88
71°F	1920	58.6	2.62	0.39	0.47	0.57	55.1	2.99	0.37	0.47	0.56	51.4	3.38	0.36	0.46	0.56	47.5	3.82	0.34	0.45	0.56
	2400	62.7	2.66	0.39	0.50	0.60	58.9	3.02	0.38	0.49	0.60	54.8	3.41	0.37	0.49	0.61	50.7	3.85	0.36	0.49	0.62
	2880	65.5	2.68	0.40	0.52	0.64	61.6	3.05	0.40	0.52	0.65	57.4	3.44	0.38	0.52	0.66	52.9	3.87	0.38	0.52	0.67

8.5 TON COOLING HIGH EFFICIENCY KDB102H4 (2ND STAGE) - SINGLE ZONE VAV SUPPLY FAN SUPPLY AIR BLOWER

Entering Wet Bulb Temperature	Total Air Volume	Outdoor Air Temperature Entering Outdoor Coil																			
		85°F					95°F					105°F					115°F				
		Total Cool Cap.	Comp. Motor Input	Sensible To Total Ratio (S/T) Dry Bulb			Total Cool Cap.	Comp. Motor Input	Sensible To Total Ratio (S/T) Dry Bulb			Total Cool Cap.	Comp. Motor Input	Sensible To Total Ratio (S/T) Dry Bulb			Total Cool Cap.	Comp. Motor Input	Sensible To Total Ratio (S/T) Dry Bulb		
				75°F	80°F	85°F			75°F	80°F	85°F			75°F	80°F	85°F			75°F	80°F	85°F
cfm	kBtuh	kW	75°F	80°F	85°F	kBtuh	kW	75°F	80°F	85°F	kBtuh	kW	75°F	80°F	85°F	kBtuh	kW	75°F	80°F	85°F	
63°F	2720	99.5	5.93	0.68	0.84	1.00	89.3	6.73	0.68	0.86	1.00	78.9	7.64	0.68	0.89	1.00	67.9	8.65	0.69	0.94	1.00
	3400	106.7	5.95	0.75	0.94	1.00	96.0	6.76	0.76	0.97	1.00	85.5	7.66	0.78	1.00	1.00	75.1	8.69	0.80	1.00	1.00
	4080	112.7	5.97	0.82	1.00	1.00	103.0	6.79	0.83	1.00	1.00	92.8	7.70	0.86	1.00	1.00	82.0	8.72	0.90	1.00	1.00
67°F	2720	109.2	5.96	0.51	0.66	0.81	98.7	6.77	0.50	0.66	0.82	87.7	7.67	0.48	0.66	0.85	76.2	8.69	0.46	0.67	0.89
	3400	115.9	5.98	0.56	0.73	0.90	105.2	6.80	0.55	0.74	0.93	93.6	7.70	0.54	0.76	0.97	81.2	8.71	0.53	0.78	1.00
	4080	121.0	6.01	0.60	0.80	0.98	109.6	6.82	0.60	0.81	1.00	97.8	7.72	0.60	0.84	1.00	85.3	8.73	0.59	0.88	1.00
71°F	2720	118.9	5.99	0.37	0.50	0.63	108.0	6.80	0.34	0.49	0.64	96.7	7.70	0.31	0.48	0.65	84.9	8.73	0.28	0.47	0.65
	3400	125.9	6.02	0.39	0.55	0.70	114.6	6.83	0.37	0.55	0.72	102.8	7.74	0.35	0.54	0.73	90.2	8.75	0.31	0.54	0.76
	4080	131.0	6.04	0.42	0.60	0.78	119.3	6.85	0.39	0.59	0.79	107.2	7.76	0.38	0.60	0.82	93.8	8.77	0.35	0.60	0.86

8.5 TON HEATING HIGH EFFICIENCY KDB102H4 - SINGLE ZONE VAV SUPPLY FAN SUPPLY AIR BLOWER

Indoor Coil Air Volume 70°F Dry Bulb cfm	Air Temperature Entering Outdoor Coil									
	65°F		45°F		25°F		5°F		-15°F	
	Total Heating Capacity	Comp. Motor Input	Total Heating Capacity	Comp. Motor Input	Total Heating Capacity	Comp. Motor Input	Total Heating Capacity	Comp. Motor Input	Total Heating Capacity	Comp. Motor Input
2720	125.3	6.31	94.9	6.44	65.0	6.58	35.4	6.26	18.0	4.57
3400	127.5	5.89	97.1	6.03	67.2	6.16	37.6	5.84	20.2	4.15
4080	129.2	5.62	98.8	5.76	68.9	5.89	39.3	5.57	21.9	3.88

COOLING/HEATING RATINGS

NOTE - For Temperatures and Capacities not shown in tables, see bulletin - Cooling Unit Rating Table Correction Factor Data in Miscellaneous Engineering Data section.

10 TON COOLING HIGH EFFICIENCY KDB122H4 (1ST STAGE) - SINGLE ZONE VAV SUPPLY FAN SUPPLY AIR BLOWER

Entering Wet Bulb Temperature	Total Air Volume	Outdoor Air Temperature Entering Outdoor Coil																				
		65°F						75°F					85°F					95°F				
		Total Cool Cap.	Comp. Motor Input	Sensible To Total Ratio (S/T) Dry Bulb			Total Cool Cap.	Comp. Motor Input	Sensible To Total Ratio (S/T) Dry Bulb			Total Cool Cap.	Comp. Motor Input	Sensible To Total Ratio (S/T) Dry Bulb			Total Cool Cap.	Comp. Motor Input	Sensible To Total Ratio (S/T) Dry Bulb			
				75°F	80°F	85°F			75°F	80°F	85°F			75°F	80°F	85°F			75°F	80°F	85°F	
		cfm	kBtuh	kW	75°F	80°F	85°F	kBtuh	kW	75°F	80°F	85°F	kBtuh	kW	75°F	80°F	85°F	kBtuh	kW	75°F	80°F	85°F
63°F	2240	57.7	3.00	0.62	0.73	0.84	55.0	3.39	0.63	0.74	0.85	51.8	3.83	0.63	0.75	0.87	48.7	4.32	0.63	0.76	0.89	
	2800	61.6	3.04	0.65	0.78	0.90	58.7	3.44	0.66	0.79	0.92	55.5	3.88	0.67	0.81	0.95	52.0	4.38	0.68	0.83	0.97	
	3360	64.7	3.08	0.68	0.83	0.97	61.3	3.48	0.70	0.85	0.99	57.7	3.92	0.71	0.87	1.00	54.1	4.41	0.72	0.89	1.00	
67°F	2240	61.6	3.04	0.51	0.60	0.69	58.7	3.44	0.51	0.60	0.70	55.6	3.88	0.50	0.60	0.71	52.3	4.38	0.50	0.61	0.72	
	2800	65.8	3.10	0.52	0.63	0.74	62.5	3.49	0.52	0.63	0.75	59.2	3.93	0.52	0.64	0.77	55.6	4.43	0.53	0.65	0.79	
	3360	68.8	3.13	0.54	0.66	0.80	65.4	3.53	0.55	0.67	0.81	61.8	3.97	0.55	0.68	0.83	58.0	4.47	0.55	0.70	0.86	
71°F	2240	65.6	3.09	0.40	0.49	0.57	62.5	3.49	0.40	0.49	0.58	59.3	3.94	0.39	0.49	0.58	55.8	4.44	0.38	0.49	0.59	
	2800	69.8	3.15	0.41	0.51	0.61	66.5	3.55	0.40	0.51	0.61	62.9	3.99	0.40	0.51	0.62	59.2	4.49	0.39	0.51	0.63	
	3360	72.9	3.19	0.41	0.53	0.64	69.4	3.59	0.41	0.53	0.65	65.5	4.03	0.41	0.53	0.66	61.6	4.54	0.41	0.54	0.68	

10 TON COOLING HIGH EFFICIENCY KDB122H4 (2ND STAGE) - SINGLE ZONE VAV SUPPLY FAN SUPPLY AIR BLOWER

Entering Wet Bulb Temperature	Total Air Volume	Outdoor Air Temperature Entering Outdoor Coil																				
		85°F						95°F					105°F					115°F				
		Total Cool Cap.	Comp. Motor Input	Sensible To Total Ratio (S/T) Dry Bulb			Total Cool Cap.	Comp. Motor Input	Sensible To Total Ratio (S/T) Dry Bulb			Total Cool Cap.	Comp. Motor Input	Sensible To Total Ratio (S/T) Dry Bulb			Total Cool Cap.	Comp. Motor Input	Sensible To Total Ratio (S/T) Dry Bulb			
				75°F	80°F	85°F			75°F	80°F	85°F			75°F	80°F	85°F			75°F	80°F	85°F	
		cfm	kBtuh	kW	75°F	80°F	85°F	kBtuh	kW	75°F	80°F	85°F	kBtuh	kW	75°F	80°F	85°F	kBtuh	kW	75°F	80°F	85°F
63°F	3200	122.5	6.90	0.69	0.83	0.98	113.3	7.82	0.69	0.85	1.00	103.8	8.85	0.70	0.88	1.00	93.8	10.09	0.72	0.91	1.00	
	4000	130.0	6.94	0.75	0.92	1.00	120.4	7.85	0.75	0.94	1.00	110.7	8.91	0.78	0.97	1.00	100.1	10.11	0.80	1.00	1.00	
	4800	136.0	6.98	0.80	0.98	1.00	126.1	7.89	0.82	1.00	1.00	116.8	8.95	0.85	1.00	1.00	106.9	10.16	0.88	1.00	1.00	
67°F	3200	132.1	6.94	0.53	0.66	0.80	122.5	7.86	0.53	0.67	0.82	112.9	8.91	0.53	0.68	0.84	102.1	10.13	0.53	0.70	0.87	
	4000	139.7	6.99	0.57	0.72	0.88	129.5	7.90	0.57	0.73	0.90	119.1	8.95	0.57	0.75	0.94	107.9	10.17	0.58	0.78	0.97	
	4800	145.1	7.03	0.60	0.78	0.95	134.7	7.95	0.61	0.80	0.98	123.7	8.99	0.62	0.82	1.00	111.8	10.18	0.62	0.85	1.00	
71°F	3200	141.8	6.99	0.40	0.52	0.64	132.0	7.92	0.39	0.52	0.65	121.9	8.98	0.37	0.52	0.66	110.7	10.16	0.36	0.52	0.68	
	4000	149.6	7.06	0.42	0.56	0.70	139.0	7.98	0.40	0.56	0.71	128.2	9.02	0.40	0.56	0.73	116.5	10.20	0.39	0.57	0.76	
	4800	155.1	7.10	0.43	0.59	0.76	144.4	8.01	0.43	0.60	0.78	133.1	9.06	0.42	0.61	0.80	120.4	10.23	0.41	0.62	0.83	

10 TON HEATING HIGH EFFICIENCY KDB122H4 - SINGLE ZONE VAV SUPPLY FAN SUPPLY AIR BLOWER

Indoor Coil Air Volume 70°F Dry Bulb cfm	Air Temperature Entering Outdoor Coil									
	65°F		45°F		25°F		5°F		-15°F	
	Total Heating Capacity	Comp. Motor Input	Total Heating Capacity	Comp. Motor Input	Total Heating Capacity	Comp. Motor Input	Total Heating Capacity	Comp. Motor Input	Total Heating Capacity	Comp. Motor Input
	kBtuh	kW	kBtuh	kW	kBtuh	kW	kBtuh	kW	kBtuh	kW
3200	146.5	7.92	112.1	7.73	77.6	7.55	46.4	6.93	23.1	5.12
4000	149.3	7.43	114.9	7.24	80.4	7.05	49.2	6.43	25.9	4.63
4800	151.3	7.10	116.9	6.91	82.4	6.73	51.3	6.11	28.0	4.30

BLOWER DATA - BELT DRIVE

7.5 AND 8.5 TON

KDB092H4B, KDB102H4B - BASE UNIT

BLOWER TABLE INCLUDES RESISTANCE FOR BASE UNIT ONLY (NO HEAT SECTION) WITH DRY INDOOR COIL AND AIR FILTERS IN PLACE. FOR ALL UNITS ADD:

- 1 – Wet indoor coil air resistance of selected unit.
- 2 – Any factory installed options air resistance (heat section, economizer, etc.)
- 3 – Any field installed accessories air resistance (duct resistance, diffuser, etc.)

Then determine from blower table blower motor output required.

See page 22 for blower motors and drives.

See page 22 for wet coil and option/accessory air resistance data.

MAXIMUM STATIC PRESSURE WITH GAS HEAT - 2.0 in. w.g.

Total Air Volume cfm	Total Static Pressure – in. w.g.													
	0.2		0.4		0.6		0.8		1.0		1.2		1.4	
	RPM	BHP	RPM	BHP	RPM	BHP	RPM	BHP	RPM	BHP	RPM	BHP	RPM	BHP
1750	480	0.19	548	0.39	618	0.57	689	0.70	758	0.81	824	0.92	885	1.07
2000	492	0.27	560	0.47	629	0.64	700	0.77	768	0.88	832	1.00	892	1.16
2250	505	0.35	573	0.55	643	0.72	713	0.85	780	0.97	842	1.10	900	1.25
2500	520	0.45	588	0.64	658	0.81	727	0.94	793	1.07	853	1.21	909	1.37
2750	536	0.55	604	0.74	674	0.91	743	1.05	806	1.19	865	1.34	919	1.50
3000	553	0.66	622	0.85	692	1.02	760	1.17	821	1.32	878	1.48	930	1.64
3250	572	0.77	641	0.98	712	1.15	778	1.32	837	1.48	892	1.64	942	1.81
3500	592	0.90	663	1.12	733	1.31	798	1.48	854	1.65	907	1.82	955	1.99
3750	614	1.04	687	1.28	756	1.48	818	1.66	872	1.83	922	2.01	969	2.19
4000	639	1.22	712	1.47	780	1.67	838	1.85	890	2.03	939	2.22	983	2.42
4250	666	1.42	740	1.68	804	1.88	859	2.06	909	2.25	956	2.45	998	2.67
4500	697	1.65	769	1.91	829	2.10	881	2.28	929	2.48	973	2.71	1013	2.95
4750	729	1.91	798	2.15	854	2.34	903	2.53	948	2.75	991	3.00	1030	3.27
5000	763	2.18	826	2.41	878	2.60	925	2.81	968	3.05	1009	3.33	1046	3.61
5250	797	2.47	854	2.69	903	2.90	947	3.12	989	3.39	1028	3.69	1064	3.99
5500	830	2.78	882	3.00	927	3.22	969	3.48	1010	3.77	1047	4.09	1083	4.40
5750	861	3.11	908	3.34	951	3.58	992	3.87	1031	4.19	1068	4.52	1102	4.84
6000	890	3.45	935	3.71	976	3.98	1016	4.31	1053	4.65	1089	4.99	1122	5.30
6250	918	3.84	961	4.12	1001	4.43	1040	4.79	1076	5.14	1110	5.48	---	---

Total Air Volume cfm	Total Static Pressure – in. w.g.											
	1.6		1.8		2		2.2		2.4		2.6	
	RPM	BHP	RPM	BHP	RPM	BHP	RPM	BHP	RPM	BHP	RPM	BHP
1750	941	1.23	992	1.40	1039	1.55	1084	1.70	1128	1.85	1156	2.08
2000	946	1.32	995	1.48	1041	1.65	1085	1.81	1127	1.97	1160	2.13
2250	952	1.42	999	1.59	1044	1.76	1087	1.93	1127	2.10	1164	2.27
2500	959	1.54	1005	1.71	1048	1.89	1089	2.07	1127	2.25	1166	2.42
2750	968	1.67	1012	1.86	1053	2.04	1092	2.23	1129	2.41	1167	2.60
3000	977	1.83	1020	2.02	1059	2.21	1096	2.41	1133	2.60	1170	2.79
3250	988	2.00	1028	2.20	1066	2.41	1102	2.61	1138	2.81	1174	3.01
3500	999	2.19	1038	2.41	1074	2.63	1109	2.84	1144	3.04	1180	3.24
3750	1010	2.41	1048	2.64	1084	2.87	1118	3.09	1152	3.29	1188	3.50
4000	1023	2.65	1060	2.90	1095	3.14	1128	3.36	1162	3.57	1198	3.77
4250	1036	2.92	1072	3.18	1106	3.42	1139	3.65	1172	3.86	1208	4.07
4500	1050	3.22	1085	3.48	1118	3.73	1151	3.96	1184	4.17	1221	4.39
4750	1065	3.55	1099	3.81	1132	4.06	1164	4.29	1198	4.51	1235	4.74
5000	1081	3.90	1114	4.17	1146	4.42	1178	4.65	1212	4.87	1250	5.09
5250	1098	4.28	1130	4.55	1162	4.80	1194	5.02	1228	5.24	1266	5.47
5500	1116	4.69	1147	4.96	1179	5.20	1211	5.42	1246	5.63	---	---
5750	1134	5.12	1165	5.38	1196	5.61	---	---	---	---	---	---
6000	1153	5.58	---	---	---	---	---	---	---	---	---	---
6250	---	---	---	---	---	---	---	---	---	---	---	---

BLOWER DATA - DIRECT DRIVE

10 TON

KDB122H4E - BASE UNIT

BLOWER TABLE INCLUDES RESISTANCE FOR BASE UNIT ONLY (NO HEAT SECTION) WITH DRY INDOOR COIL AND AIR FILTERS IN PLACE. FOR ALL UNITS ADD:

- 1 – Wet indoor coil air resistance of selected unit.
- 2 – Any factory installed options air resistance (heat section, economizer, etc.)
- 3 – Any field installed accessories air resistance (duct resistance, diffuser, etc.)

See page 22 for wet coil and option/accessory air resistance data.

MAXIMUM STATIC PRESSURE WITH GAS HEAT - 2.0 in. w.g.

Total Air Volume cfm	Total Static Pressure - in. w.g.													
	0.2		0.4		0.6		0.8		1.0		1.2		1.4	
	RPM	Watts	RPM	Watts	RPM	Watts	RPM	Watts	RPM	Watts	RPM	Watts	RPM	Watts
1750	711	188	771	279	836	366	905	453	975	544	1044	640	1109	737
2000	752	242	812	332	876	420	944	510	1011	606	1075	709	1138	812
2250	799	300	860	389	923	479	988	575	1052	678	1113	787	1171	896
2500	853	362	914	453	976	548	1038	650	1097	761	1154	877	1209	990
2750	914	434	974	529	1033	629	1091	739	1146	858	1199	979	1250	1098
3000	980	513	1037	614	1092	720	1146	837	1198	961	1247	1088	1295	1215
3250	1048	598	1101	705	1153	819	1203	941	1251	1071	1298	1206	1343	1343
3500	1116	693	1166	809	1214	931	1261	1060	1307	1198	1351	1341	1395	1489
3750	1185	806	1232	931	1277	1063	1322	1201	1365	1348	1407	1499	1448	1657
4000	1254	937	1299	1072	1341	1214	1383	1363	1424	1518	1464	1679	1503	1844
4250	1324	1089	1366	1234	1406	1386	1445	1545	1484	1708	1522	1876	1559	2046
4500	1395	1262	1433	1417	1471	1579	1508	1745	1544	1913	1581	2084	1616	2256
4750	1465	1455	1501	1619	1536	1787	1571	1957	1606	2128	1641	2299	1675	2470
5000	1534	1666	1568	1834	1602	2004	1635	2174	1668	2345	1701	2514	1735	2682
5250	1603	1887	1635	2055	1667	2224	1699	2392	1731	2559	1763	2724	---	---
5500	1671	2110	1702	2275	1733	2441	1764	2605	---	---	---	---	---	---
5750	1738	2325	1768	2488	---	---	---	---	---	---	---	---	---	---

Total Air Volume cfm	Total Static Pressure - in. w.g.											
	1.6		1.8		2.0		2.2		2.4		2.6	
	RPM	Watts	RPM	Watts	RPM	Watts	RPM	Watts	RPM	Watts	RPM	Watts
1750	1172	833	1231	932	1287	1039	1340	1156	1391	1283	1442	1426
2000	1197	913	1253	1019	1306	1135	1357	1261	1407	1398	1457	1547
2250	1227	1003	1280	1117	1330	1242	1379	1378	1428	1525	1477	1680
2500	1261	1103	1311	1226	1360	1361	1407	1507	1454	1663	1501	1826
2750	1299	1219	1347	1350	1394	1494	1440	1649	1485	1813	1530	1982
3000	1342	1346	1388	1487	1432	1640	1476	1803	1520	1973	1563	2146
3250	1388	1485	1432	1638	1475	1800	1517	1969	1558	2143	1600	2319
3500	1437	1643	1479	1805	1519	1975	1560	2148	1600	2325	1640	2502
3750	1489	1821	1528	1990	1567	2164	1605	2340	1645	2517	1685	2693
4000	1541	2014	1579	2187	1616	2364	1654	2540	1693	2715	1732	2887
4250	1596	2218	1632	2393	1668	2569	1705	2742	1743	2913	---	---
4500	1652	2429	1687	2603	1722	2775	1759	2944	---	---	---	---
4750	1709	2641	1743	2811	1778	2979	---	---	---	---	---	---
5000	1768	2850	---	---	---	---	---	---	---	---	---	---
5250	---	---	---	---	---	---	---	---	---	---	---	---
5500	---	---	---	---	---	---	---	---	---	---	---	---
5750	---	---	---	---	---	---	---	---	---	---	---	---

BLOWER DATA

FACTORY INSTALLED BELT DRIVE KIT SPECIFICATIONS

Nominal hp	Maximum hp	Drive Kit Number	RPM Range
2	2.3	1	590 - 890
2	2.3	2	800 - 1105
2	2.3	3	795 - 1195
3	3.45	4	730 - 970
3	3.45	5	940 - 1200
3	3.45	6	1015 - 1300
5	5.75	10	900 - 1135
5	5.75	11	1040 - 1315
5	5.75	12	1125 - 1425

NOTE - Using total air volume and system static pressure requirements determine from blower performance tables rpm and motor output required. Maximum usable output of motors furnished are shown. In Canada, nominal motor output is also maximum usable motor output. If motors of comparable output are used, be sure to keep within the service factor limitations outlined on the motor nameplate.

NOTE - Units equipped with Single Zone VAV Supply Fan option are limited to a motor service factor of 1.0.

POWER EXHAUST FAN PERFORMANCE

Return Air System Static Pressure in. w.g.	Air Volume Exhausted cfm
0	3175
0.05	2955
0.10	2685
0.15	2410
0.20	2165
0.25	1920
0.30	1420
0.35	1200

FACTORY INSTALLED OPTIONS/FIELD INSTALLED ACCESSORY AIR RESISTANCE - in. w.g.

Air Volume cfm	Wet Indoor Coil	Gas Heat Exchanger			Economizer	Filters	
	092,102,122	Standard Heat	Medium Heat	High Heat		MERV 8	MERV 13
1750	0.04	0.06	0.02	0.02	0.05	0.01	0.03
2000	0.05	0.07	0.05	0.06	0.06	0.01	0.03
2250	0.06	0.07	0.07	0.08	0.08	0.01	0.04
2500	0.07	0.09	0.10	0.11	0.11	0.01	0.05
2750	0.08	0.09	0.11	0.12	0.12	0.02	0.05
3000	0.10	0.11	0.12	0.13	0.13	0.02	0.06
3250	0.11	0.12	0.15	0.16	0.15	0.02	0.06
3500	0.12	0.12	0.16	0.17	0.15	0.03	0.07
3750	0.14	0.14	0.19	0.20	0.15	0.03	0.08
4000	0.15	0.14	0.21	0.22	0.19	0.04	0.08
4250	0.17	0.14	0.24	0.28	0.19	0.04	0.09
4500	0.19	0.15	0.26	0.32	0.22	0.04	0.09
4750	0.20	0.16	0.29	0.37	0.25	0.05	0.10
5000	0.22	0.16	0.34	0.43	0.29	0.06	0.10
5250	0.24	0.16	0.37	0.47	0.32	0.06	0.11
5500	0.25	0.18	0.44	0.54	0.34	0.07	0.12
5750	0.27	0.19	0.49	0.59	0.45	0.07	0.12
6000	0.29	0.20	0.54	0.64	0.52	0.08	0.13

BLOWER DATA

CEILING DIFFUSERS AIR RESISTANCE - in. w.g.

Unit Size	RTD11 Step-Down Diffuser			FD11 Flush Diffuser	
	Air Volume cfm	2 Ends Open	1 Side, 2 Ends Open		All Ends & Sides Open
092 Models	2400	0.21	0.18	0.15	0.14
	2600	0.24	0.21	0.18	0.17
	2800	0.27	0.24	0.21	0.20
	3000	0.32	0.29	0.25	0.25
	3200	0.41	0.37	0.32	0.31
	3400	0.50	0.45	0.39	0.37
	3600	0.61	0.54	0.48	0.44
	3800	0.73	0.63	0.57	0.51
102 & 122 Models	3600	0.36	0.28	0.23	0.15
	3800	0.40	0.32	0.26	0.18
	4000	0.44	0.36	0.29	0.21
	4200	0.49	0.40	0.33	0.24
	4400	0.54	0.44	0.37	0.27
	4600	0.60	0.49	0.42	0.31
	4800	0.65	0.53	0.46	0.35
	5000	0.69	0.58	0.50	0.39
5200	0.75	0.62	0.54	0.43	

CEILING DIFFUSER AIR THROW DATA

Model No.	Air Volume	¹ Effective Throw Range	
		RTD11 Step-Down	FD11 Flush
	cfm	ft.	ft.
092 Models	2600	24 - 29	19 - 24
	2800	25 - 30	20 - 28
	3000	27 - 33	21 - 29
	3200	28 - 35	22 - 29
	3400	30 - 37	22 - 30
102 & 122 Models	3600	25 - 33	22 - 29
	3800	27 - 35	22 - 30
	4000	29 - 37	24 - 33
	4200	32 - 40	26 - 35
	4400	34 - 42	28 - 37

¹ Throw is the horizontal or vertical distance an air stream travels on leaving the outlet or diffuser before the maximum velocity is reduced to 50 ft. per minute. Four sides open.

ELECTRICAL DATA**7.5 TON****BELT DRIVE BLOWER - KDB092H4**

¹ Voltage - 60hz		208/230V - 3 Ph			460V - 3 Ph			575V - 3 Ph		
Compressor 1	Rated Load Amps	13.1			6.1			4.4		
	Locked Rotor Amps	83.1			41			33		
Compressor 2	Rated Load Amps	13.1			6.1			4.4		
	Locked Rotor Amps	83.1			41			33		
Outdoor Fan Motors (2)	Full Load Amps	2.8			1.4			1.1		
	(total)	(5.6)			(2.8)			(2.2)		
Power Exhaust (1) 0.33 HP	Full Load Amps	2.4			1.3			1		
Service Outlet 115V GFI (amps)		15			15			20		
Indoor Blower Motor	Horsepower	2	3	5	2	3	5	2	3	5
	Full Load Amps	7.5	10.6	16.7	3.4	4.8	7.6	2.7	3.9	6.1
² Maximum Overcurrent Protection	Unit Only	50	50	60	25	25	30	15	20	20
	With (1) 0.33 HP Power Exhaust	50	60	70	25	25	30	20	20	25
³ Minimum Circuit Ampacity	Unit Only	43	46	53	20	22	25	15	16	19
	With (1) 0.33 HP Power Exhaust	45	49	56	22	23	26	16	17	20

ELECTRICAL ACCESSORIES

Disconnect	54W56	54W56	54W56
-------------------	--------------	--------------	--------------

NOTE - All units have a minimum Short Circuit Current Rating (SCCR) of 5000 amps.

¹ Extremes of operating range are plus and minus 10% of line voltage.² HACR type breaker or fuse.³ Refer to National or Canadian Electrical Code manual to determine wire, fuse and disconnect size requirements.**ELECTRICAL DATA****8.5 TON****BELT DRIVE BLOWER - KDB102H4**

¹ Voltage - 60hz		208/230V - 3 Ph			460V - 3 Ph			575V - 3 Ph		
Compressor 1	Rated Load Amps	14.5			6.3			6		
	Locked Rotor Amps	98			55			41		
Compressor 2	Rated Load Amps	14.5			6.3			6		
	Locked Rotor Amps	98			55			41		
Outdoor Fan Motors (2)	Full Load Amps	2.8			1.4			1.1		
	(total)	(5.6)			(2.8)			(2.2)		
Power Exhaust (1) 0.33 HP	Full Load Amps	2.4			1.3			1		
Service Outlet 115V GFI (amps)		15			15			20		
Indoor Blower Motor	Horsepower	2	3	5	2	3	5	2	3	5
	Full Load Amps	7.5	10.6	16.7	3.4	4.8	7.6	2.7	3.9	6.1
² Maximum Overcurrent Protection	Unit Only	60	60	70	25	25	30	20	25	25
	With (1) 0.33 HP Power Exhaust	60	60	70	25	25	30	25	25	25
³ Minimum Circuit Ampacity	Unit Only	46	49	56	21	22	25	19	20	22
	With (1) 0.33 HP Power Exhaust	49	52	58	22	24	27	20	21	23

ELECTRICAL ACCESSORIES

Disconnect	54W56	54W56	54W56
-------------------	--------------	--------------	--------------

NOTE - All units have a minimum Short Circuit Current Rating (SCCR) of 5000 amps.

¹ Extremes of operating range are plus and minus 10% of line voltage.² HACR type breaker or fuse.³ Refer to National or Canadian Electrical Code manual to determine wire, fuse and disconnect size requirements.

ELECTRICAL DATA**10 TON****DIRECT DRIVE BLOWER - KDBI22H4**

¹ Voltage - 60hz		208/230V - 3 Ph	460V - 3 Ph	575V - 3 Ph
Compressor 1	Rated Load Amps	15.6	7.8	5.8
	Locked Rotor Amps	110	52	38.9
Compressor 2	Rated Load Amps	15.6	7.8	5.8
	Locked Rotor Amps	110	52	38.9
Outdoor Fan Motors (3)	Full Load Amps	2.8	1.4	1.1
	(total)	(8.4)	(4.2)	(3.3)
Power Exhaust (1) 0.33 HP	Full Load Amps	2.4	1.3	1
Service Outlet 115V GFI (amps)		15	15	20
Indoor Blower Motor	Horsepower	3.75	3.75	3.75
	Full Load Amps	8.8	4.3	3.4
² Maximum Overcurrent Protection	Unit Only	60	30	25
	With (1) 0.33 HP Power Exhaust	70	35	25
³ Minimum Circuit Ampacity	Unit Only	53	27	20
	With (1) 0.33 HP Power Exhaust	60	30	23

ELECTRICAL ACCESSORIES

Disconnect	54W56	54W56	54W56
-------------------	--------------	--------------	--------------

NOTE - All units have a minimum Short Circuit Current Rating (SCCR) of 5000 amps.

¹ Extremes of operating range are plus and minus 10% of line voltage.

² HACR type breaker or fuse.

³ Refer to National or Canadian Electrical Code manual to determine wire, fuse and disconnect size requirements.

UNIT CLEARANCES

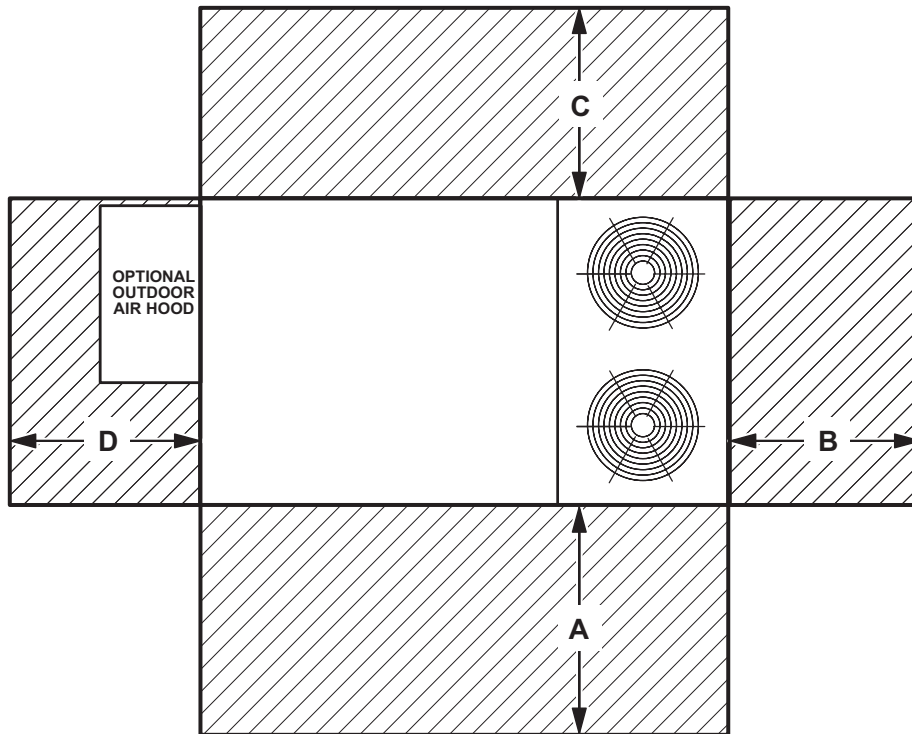

¹ Unit Clearance	A		B		C		D		Top Clearance
	in.	mm	in.	mm	in.	mm	in.	mm	
Service Clearance	60	1524	36	914	36	914	60	1524	Unobstructed
Minimum Operation Clearance	36	914	36	914	36	914	36	914	

NOTE - Entire perimeter of unit base requires support when elevated above the mounting surface.

¹ **Service Clearance** - Required for removal of serviceable parts.

Minimum Operation Clearance - Required clearance for proper unit operation.

OUTDOOR SOUND DATA

Unit Model Number	Octave Band Sound Power Levels dBA, re 10 ⁻¹² Watts Center Frequency - Hz							¹ Sound Rating Number (dBA)
	125	250	500	1000	2000	4000	8000	
KDB092, 102	72	75	76	73	67	60	50	86
KDB122	73	74	75	72	66	60	50	85

Note - The octave sound power data does not include tonal corrections.

¹ Sound Rating Number according to AHRI Standard 270-95 or AHRI Standard 370-2001 (includes pure tone penalty). Sound Rating Number is the overall A-Weighted Sound Power Level, (L_{wa}), dB (100 Hz to 10,000 Hz).

OPTIONAL CONVENTIONAL TEMPERATURE CONTROL SYSTEMS

Item	Model No.	Catalog No.	
<p>7-DAY PROGRAMMABLE THERMOSTAT - BACNET COMPATIBLE WITH REHEAT FUNCTION</p>  <ul style="list-style-type: none"> • For units with or without ¹ Humiditrol® • BTL listed MS/TP ensures compatibility with any BACnet system • Built-in control programs for conventional and heat pump applications • Conventional systems up to 3-stage heat and 3-stage cool • Heat pumps with 1 or 2 compressors and up to 2-stage auxiliary heat • On-board temperature and humidity sensor • Multiple configurable inputs and outputs enable advanced control strategies • Set-up Wizard enables rapid system configuration • No special tools required for installation or commissioning • Seven-day (2, 4 or 6 event) occupancy scheduling per day • Backlit 5-inch LCD touchscreen 	---	Y8241	
<p>¹ BACnet Thermostat (Y8241) will control units with and without the Humiditrol® option. If there is a mix of units equipped with and without Humiditrol on the same site, this thermostat can be used for all units if desired.</p>			
BACnet Controls (no reheat capability)	BACnet® Module (factory or field installed) BACnet® Room Sensor with Display (field installed) BACnet® Room Sensor without Display (field installed)	K0CTRL31B-2 K0SNSR01FF1 K0SNSR00FF1	16X71 97W23 97W24
Optional Accessories	Plenum Cable (RJ45/CAT5 75 ft.)	K0MISC00FF1	97W25

WEIGHT DATA

Model Number	Net		Shipping	
	lbs.	kg	lbs.	kg
KDB092H Base Unit	1121	509	1206	548
KDB092H Max. Unit	1264	574	1349	612
KDB102H Base Unit	1123	510	1208	548
KDB102H Max. Unit	1266	575	1351	613
KDB122H Base Unit	1264	574	1349	612
KDB122H Max. Unit	1407	639	1492	677

OPTIONS / ACCESSORIES

Model Number	Shipping Weight	
	lbs.	kg

ECONOMIZER / OUTDOOR AIR / EXHAUST**Economizer**

Economizer Dampers	60	27
Barometric Relief Dampers (downflow)	8	4
Barometric Relief Damper Hood (downflow)	25	11
Outdoor Air Hood (downflow)	23	10

Outdoor Air Dampers

Outdoor Air Damper Section - Automatic	51	23
Outdoor Air Damper Section - Manual	39	18

Power Exhaust

	31	14
--	----	----

GAS HEAT EXCHANGER (NET WEIGHT)

Medium Heat (adder over standard heat)	9	4
High Heat (adder over standard heat)	32	15

SINGLE ZONE VAV SUPPLY FAN SUPPLY AIR BLOWER OPTION

Variable Frequency Drive (VFD) and associated components	10	5
--	----	---

ROOF CURBS**Hybrid Roof Curbs, Downflow**

8 in. height	60	27
14 in. height	85	39
18 in. height	100	45
24 in. height	125	57

Adjustable Pitch Curb, Downflow

14 in. height	191	82
---------------	-----	----

PACKAGING

LTL Packaging (less than truck load)	105	48
--------------------------------------	-----	----

CEILING DIFFUSERS**Step-Down**

RTD11-95S	118	54
RTD11-135S	135	61

Flush

FD11-95S	118	54
FD11-135S	135	61

Transitions

C1DIFF30B-1	30	14
C1DIFF31B-1	32	15

DIMENSIONS - UNIT - 092-102 MODELS

Model No.	CORNER WEIGHTS														CENTER OF GRAVITY									
	AA				BB				CC				DD				EE				FF			
	Base		Max.		Base		Max.		Base		Max.		Base		Max.		Base		Max.		Base		Max.	
	lbs.	kg	lbs.	kg	lbs.	kg	lbs.	kg	lbs.	kg	lbs.	kg	lbs.	kg	in.	mm	in.	mm	in.	mm	in.	mm	in.	mm
KDB092	296	134	334	152	248	112	279	127	260	118	293	133	318	144	358	163	44	1118	43	1092	27	686	28	711
KDB102	297	135	334	152	248	113	280	127	260	118	293	133	318	144	359	163	44	1118	43	1092	27	686	28	711

Base Unit - The unit with NO OPTIONS.

Max. Unit - The unit with ALL OPTIONS Installed (Economizer, etc.).

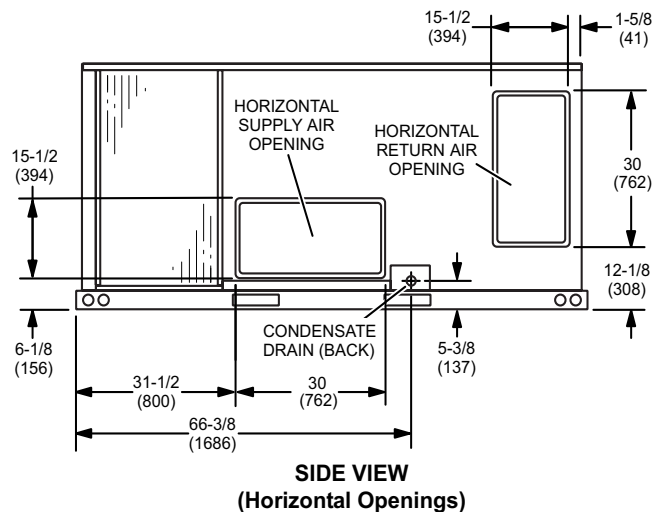
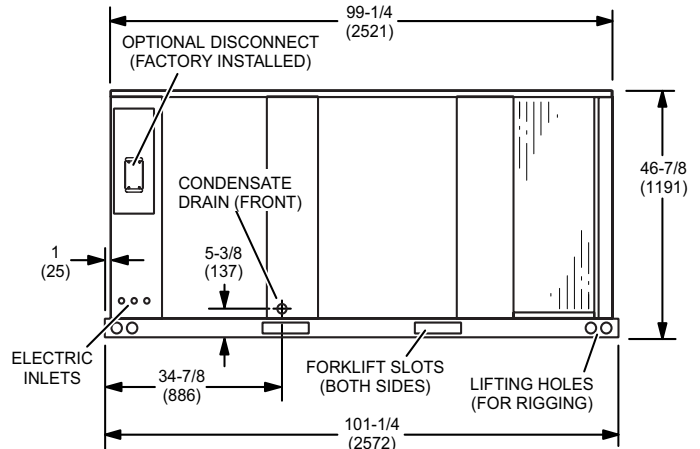
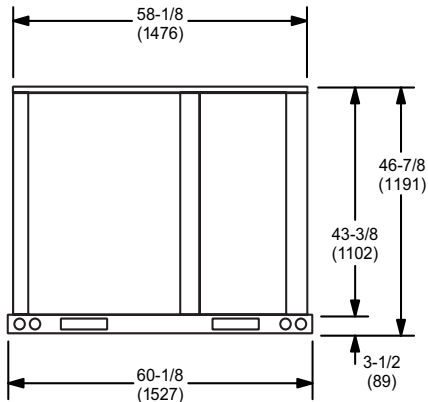
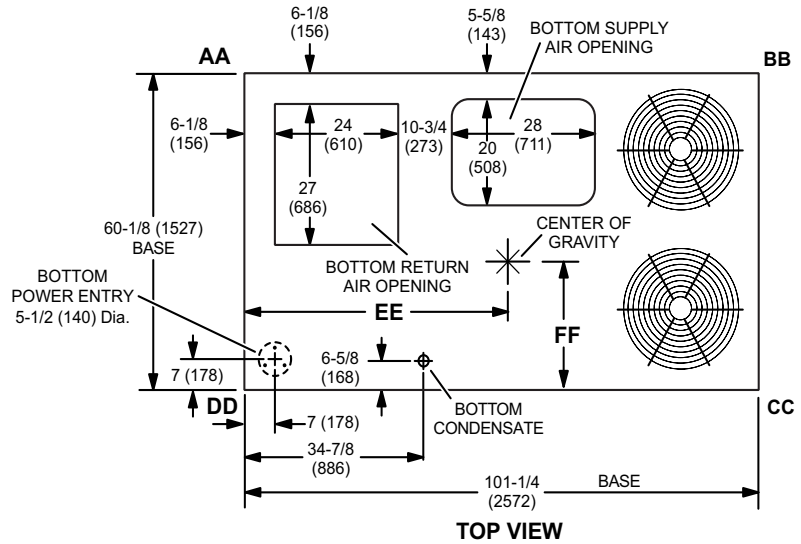

DIMENSIONS - UNIT - 122 MODELS

Model No.	CORNER WEIGHTS												CENTER OF GRAVITY											
	AA				BB				CC				DD				EE				FF			
	Base		Max.		Base		Max.		Base		Max.		Base		Max.		Base		Max.		Base		Max.	
	lbs.	kg	lbs.	kg	lbs.	kg	lbs.	kg	lbs.	kg	lbs.	kg	lbs.	kg	lbs.	kg	in.	mm	in.	mm	in.	mm	in.	mm
KDB122	328	149	366	166	284	129	316	144	299	136	333	151	352	160	392	178	56.5	1435	55.5	1010	25.5	648	26.5	673

Base Unit - The unit with NO OPTIONS.

Max. Unit - The unit with ALL OPTIONS Installed (Economizer, etc.).

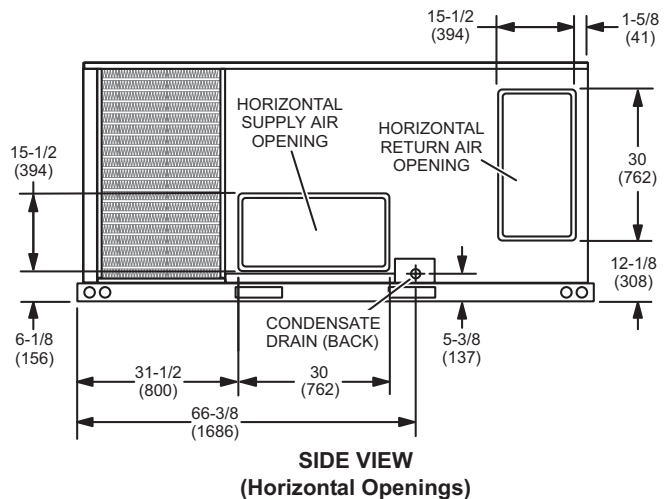
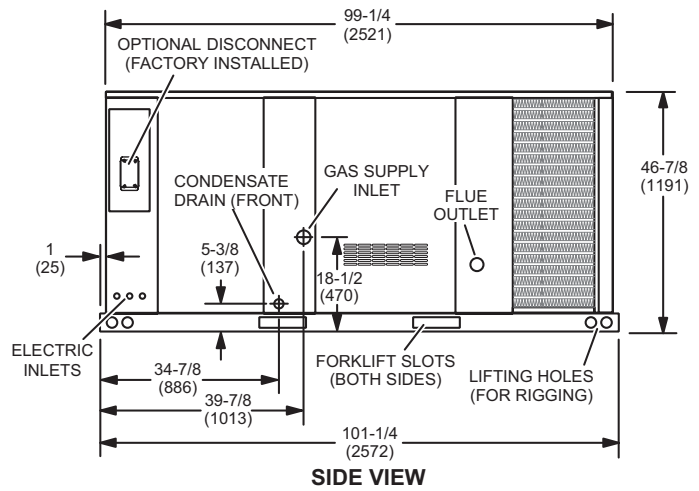
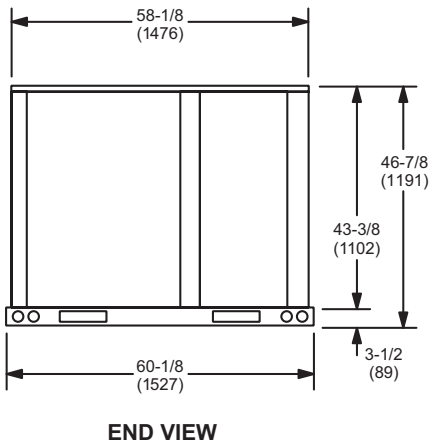
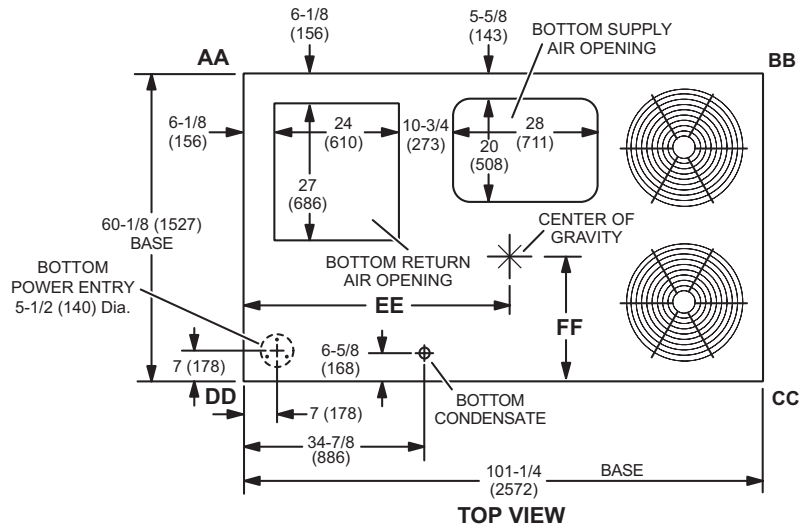

UNIT ON CURB LOCATION - KDB122

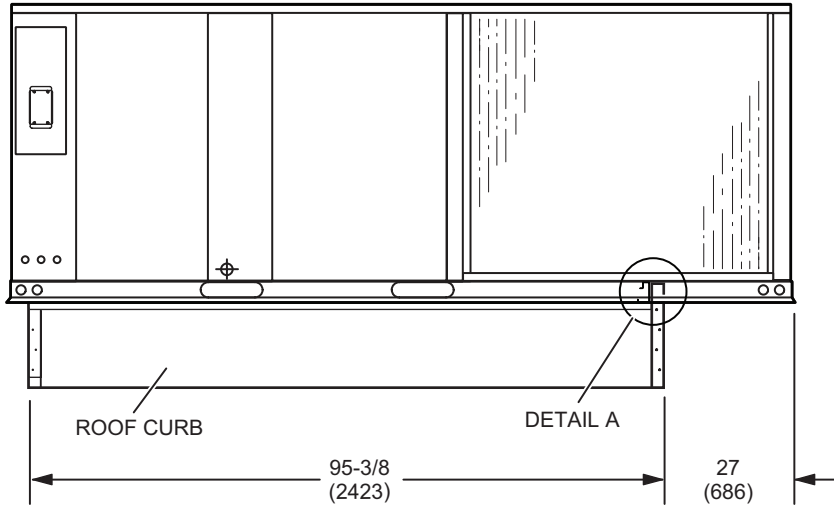

SIDE VIEW

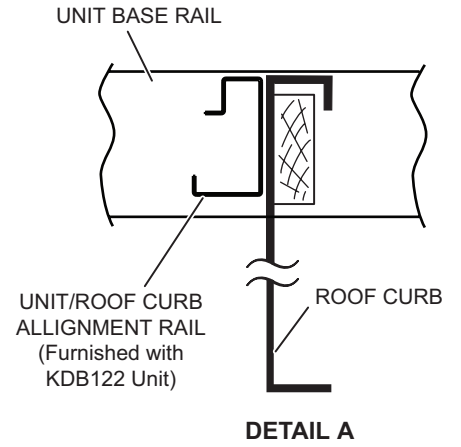

OUTDOOR AIR HOOD DETAIL

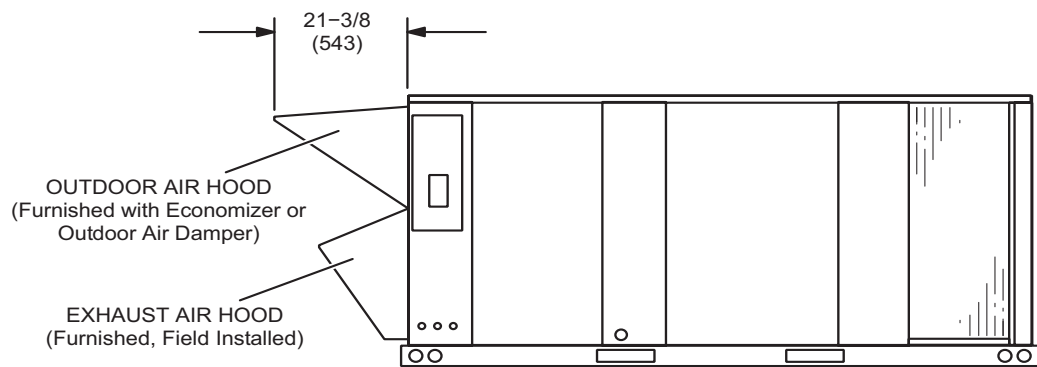

DIMENSIONS - ACCESSORIES

HORIZONTAL ECONOMIZER APPLICATION

(With Furnished Barometric Relief Dampers and Optional Horizontal Discharge Kit - Required)

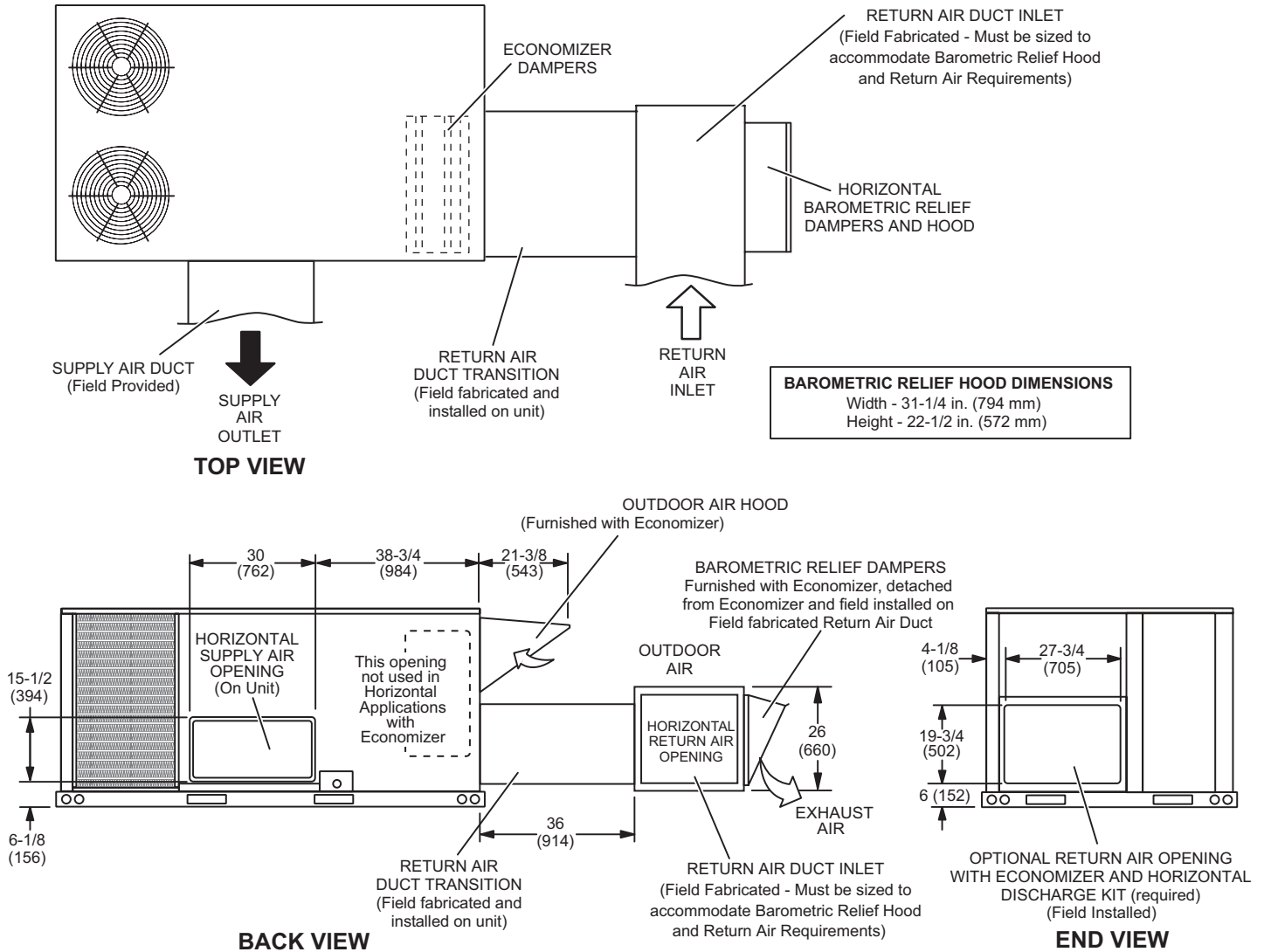

NOTE - Return Air Duct and Transition must be supported.

BAROMETRIC RELIEF DAMPERS (Furnished with Economizer)

(Field installed in horizontal return air duct adjacent to unit)

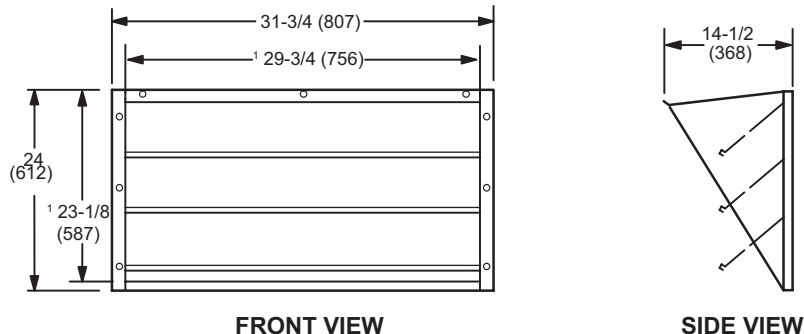

¹ NOTE - Opening size required in return air duct.

DIMENSIONS - ACCESSORIES

HORIZONTAL ECONOMIZER APPLICATION

(with Optional Low Profile Horizontal Barometric Relief Dampers and Horizontal Discharge Kit - Required)

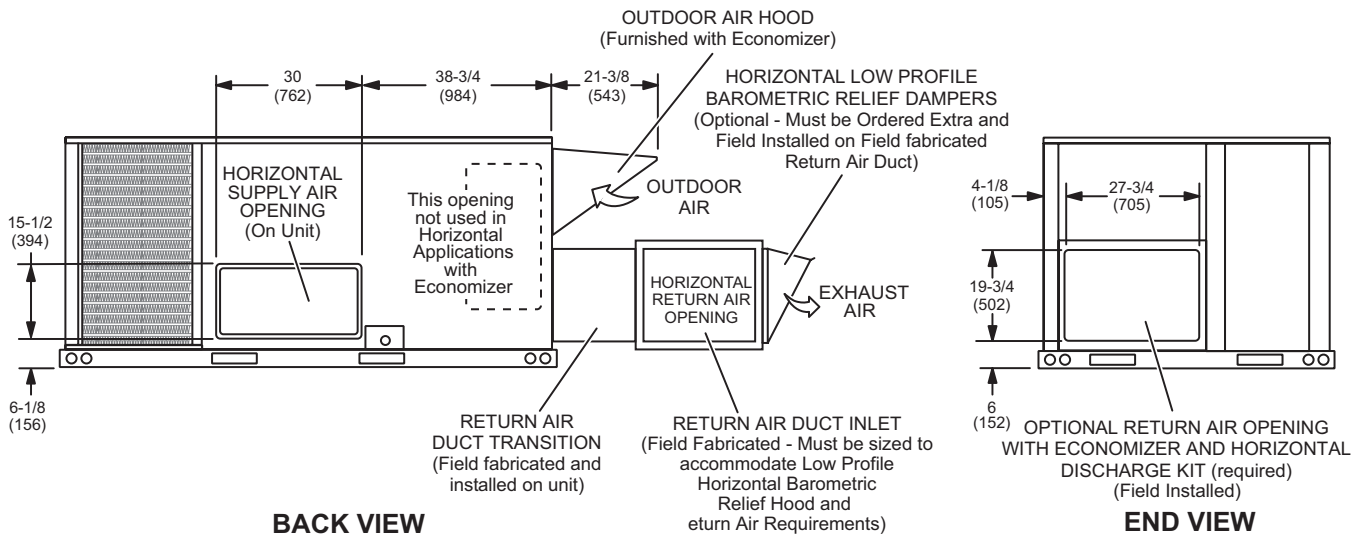
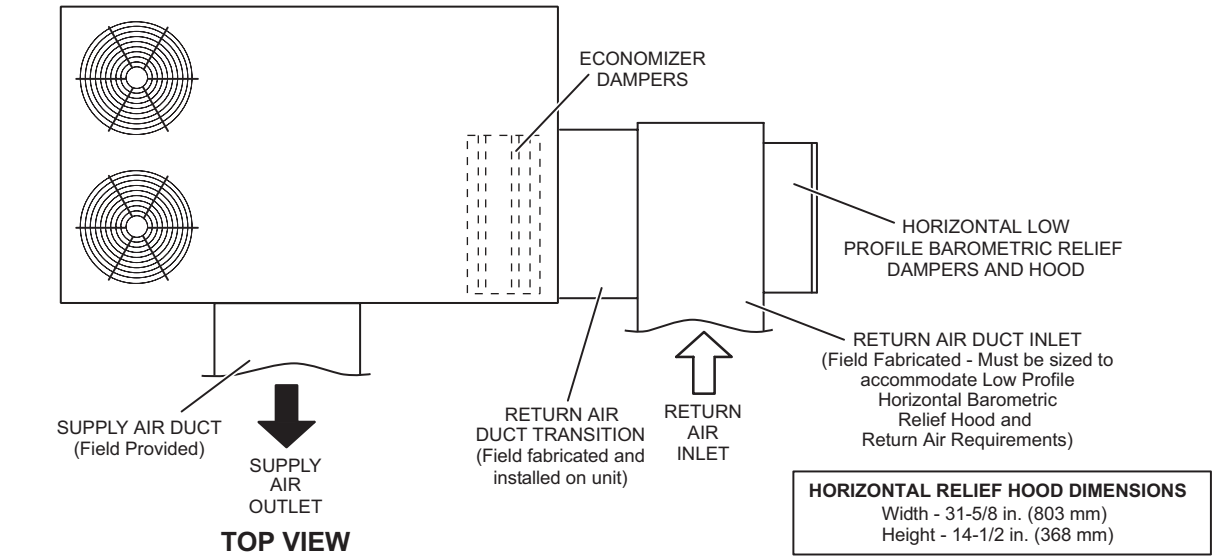

NOTE - Return Air Duct and Transition must be supported.

HORIZONTAL LOW PROFILE BAROMETRIC RELIEF DAMPERS (Field installed in horizontal return air duct adjacent to unit)

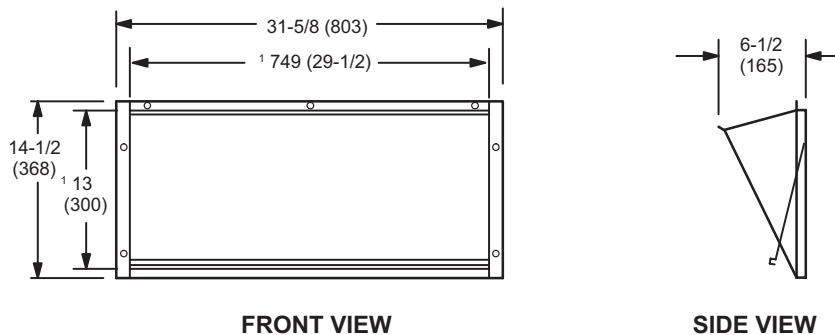

¹ NOTE - Opening size required in return air duct.

DIMENSIONS - ACCESSORIES

HYBRID ROOF CURBS - DOUBLE DUCT OPENING

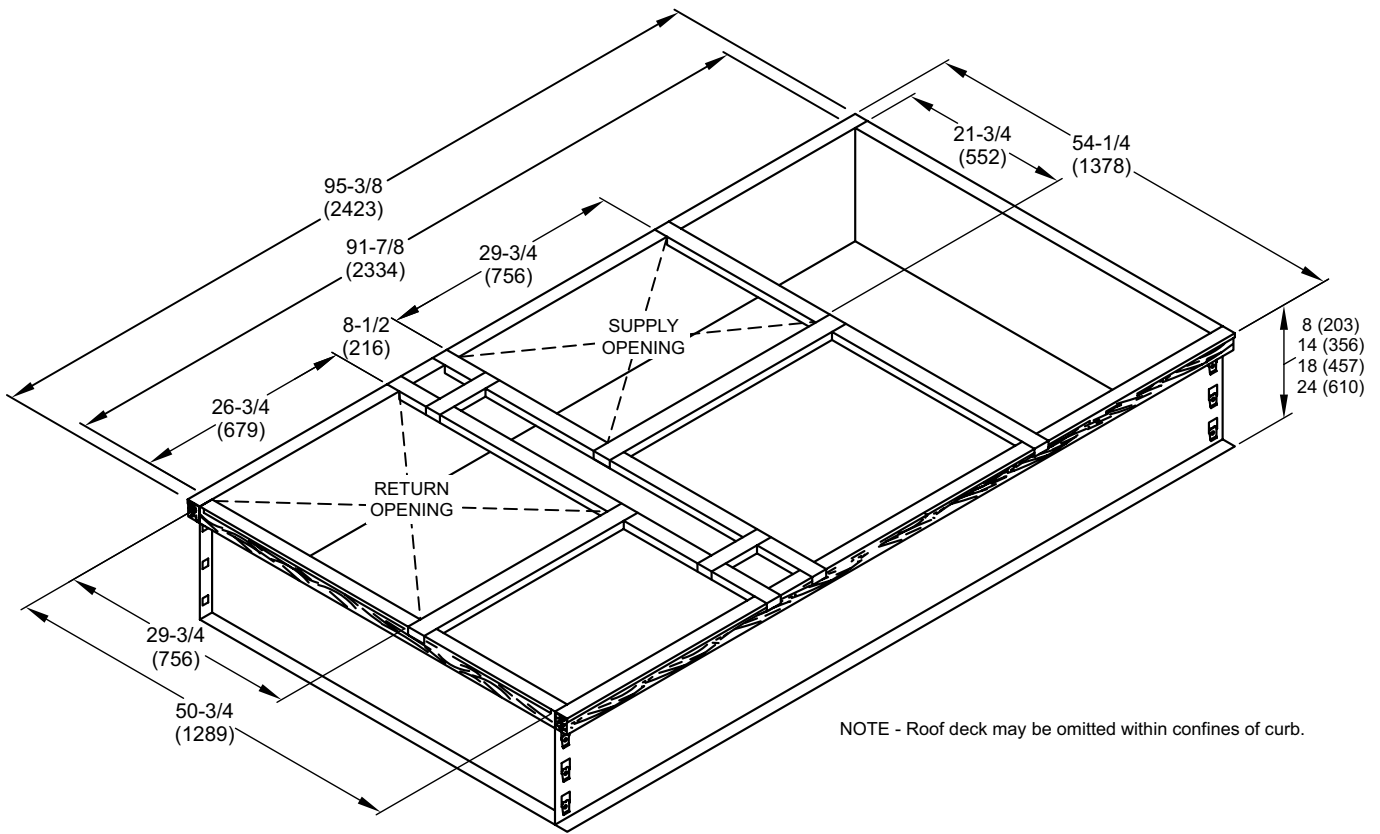

TYPICAL FLASHING DETAIL FOR ROOF CURB

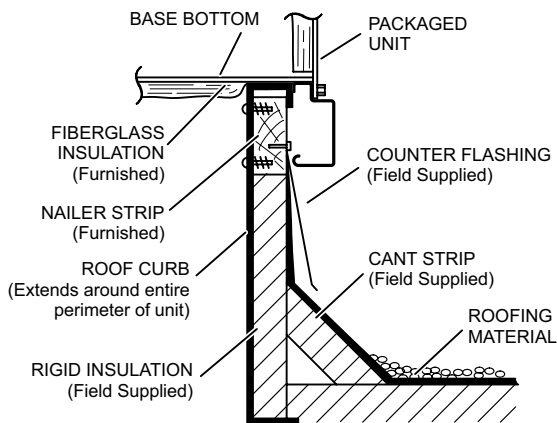

DETAIL ROOF CURB

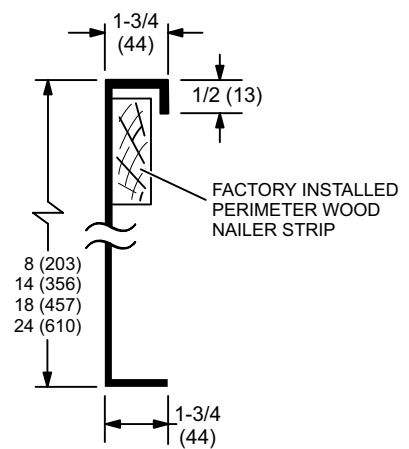

DIMENSIONS - ACCESSORIES

ADJUSTABLE PITCH CURBS - DOUBLE DUCT OPENING

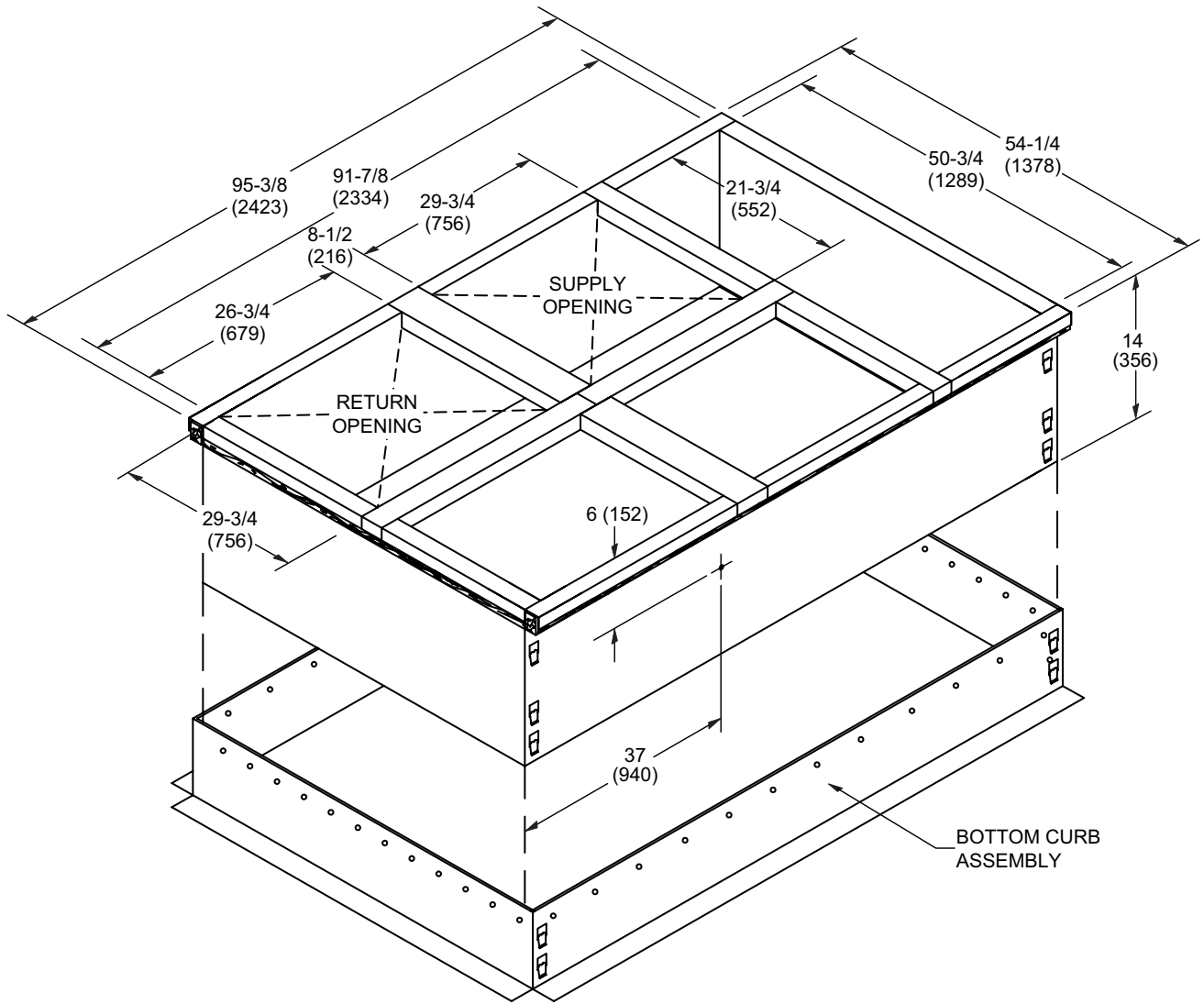

NOTE - Maximum slope pitch is 3/4 in. per 1 foot (19 mm per 305 mm) in any one direction.

TYPICAL FLASHING DETAIL FOR ROOF CURB

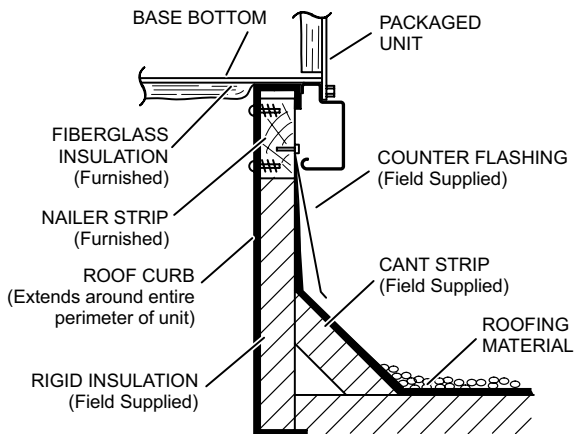

DETAIL ROOF CURB

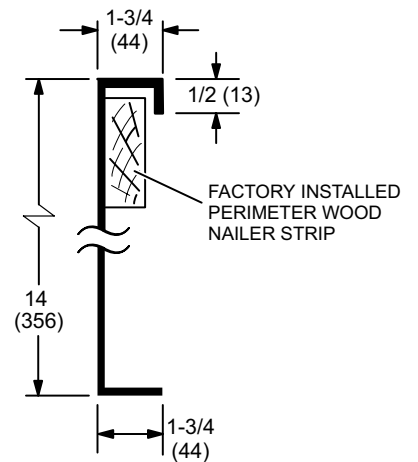

DIMENSIONS - ACCESSORIES

ROOF CURBS WITH SUPPLY & RETURN AIR TRANSITIONS FOR CEILING DIFFUSERS

C1DIFF30B-1 ROUND TRANSITIONS
(for 092 models)

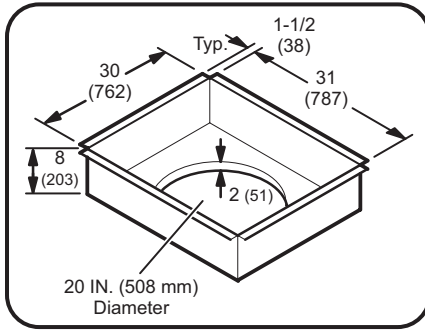

C1DIFF31B-1 RECTANGULAR TRANSITIONS
(for 102 and 122 models)

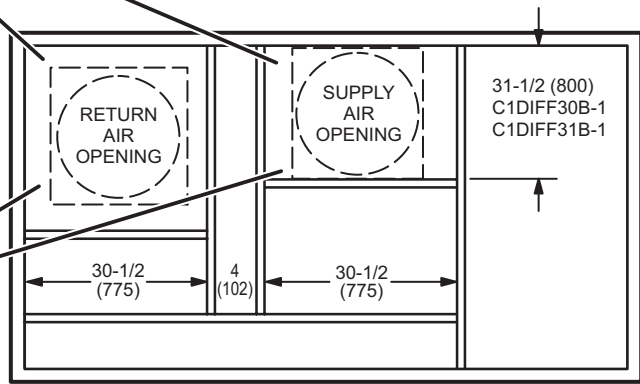
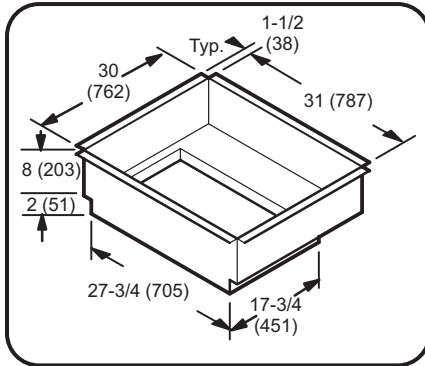

TOP VIEW

DIMENSIONS - ACCESSORIES

COMBINATION CEILING SUPPLY AND RETURN DIFFUSERS

STEP-DOWN CEILING DIFFUSER

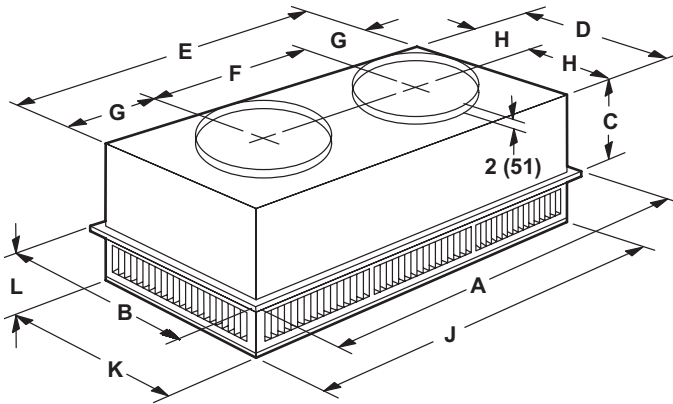

FLUSH CEILING DIFFUSER

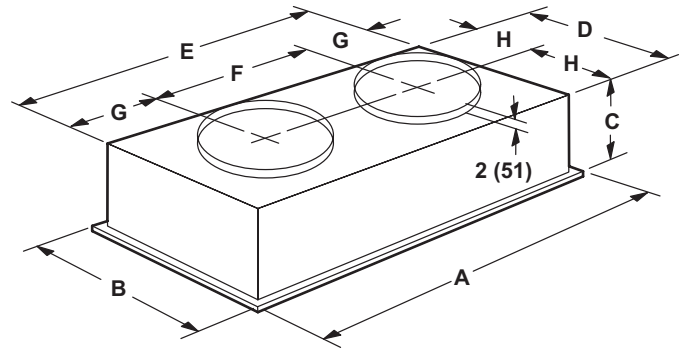

Model Number		RTD11-95S
A	in.	47-5/8
	mm	1159
B	in.	29-5/8
	mm	752
C	in.	14-3/8
	mm	365
D	in.	27-1/2
	mm	699
E	in.	45-1/2
	mm	1158
F	in.	22-1/2
	mm	572
G	in.	11-1/2
	mm	292
H	in.	13-3/4
	mm	349
J	in.	45-1/2
	mm	1156
K	in.	27-1/2
	mm	699
L	in.	8-1/8
	mm	206
Duct Size	in.	20 round
	mm	508 round

Model Number		FD11-95S
A	in.	47-5/8
	mm	1159
B	in.	29-5/8
	mm	752
C	in.	16-5/8
	mm	422
D	in.	27
	mm	686
E	in.	45
	mm	1143
F	in.	22-1/2
	mm	572
G	in.	11-1/4
	mm	286
H	in.	13-1/2
	mm	343
Duct Size	in.	20 round
	mm	508 round

DIMENSIONS - ACCESSORIES

COMBINATION CEILING SUPPLY AND RETURN DIFFUSERS

STEP-DOWN CEILING DIFFUSER

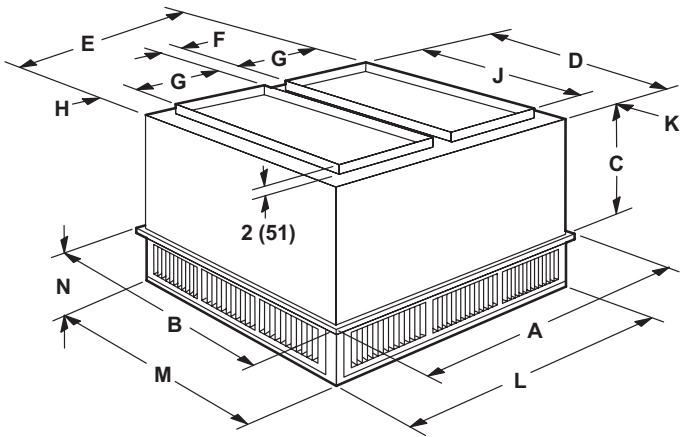

FLUSH CEILING DIFFUSER

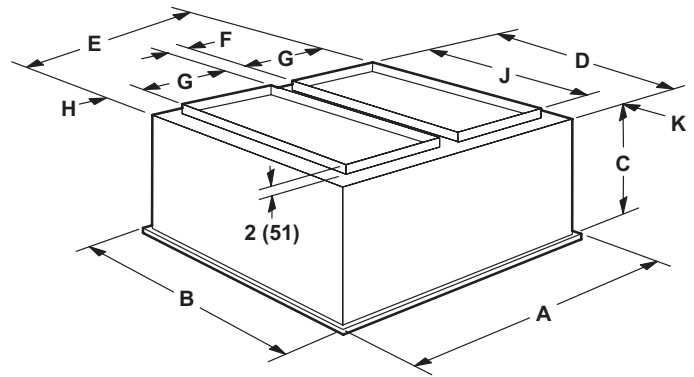

Model Number		RTD11-135S
A	in.	47-5/8
	mm	1210
B	in.	35-5/8
	mm	905
C	in.	20-5/8
	mm	524
D	in.	33-1/2
	mm	851
E	in.	45-1/2
	mm	1156
F	in.	4-1/2
	mm	114
G	in.	18
	mm	457
H	in.	2-1/2
	mm	64
J	in.	28
	mm	711
K	in.	2-3/4
	mm	70
L	in.	45-1/2
	mm	1156
M	in.	33-1/2
	mm	851
N	in.	9-1/8
	mm	232
Duct Size	in.	18 x 28
	mm	457 x 711

Model Number		FD11-135S
A	in.	47-5/8
	mm	1210
B	in.	35-5/8
	mm	905
C	in.	23-1/4
	mm	591
D	in.	33
	mm	838
E	in.	45
	mm	1143
F	in.	4-1/2
	mm	114
G	in.	18
	mm	457
H	in.	2-1/4
	mm	57
J	in.	28
	mm	711
K	in.	2-1/2
	mm	64
Duct Size	in.	18 x 28
	mm	457 x 711

REVISIONS

Section	Description
Options / Accessories	Updated High Performance Economizer model and catalog numbers.



Visit us at www.allied-commercial.com

For the latest technical information, visit us at www.allied-commercial.com

Contact us at 1-800-448-5872

NOTE - Due to Allied Commercial ongoing commitment to quality, Specifications, Ratings and Dimensions subject to change without notice and without incurring liability. Improper installation, adjustment, alteration, service or maintenance can cause property damage or personal injury. Installation and service must be performed by a qualified installer and servicing agency.

CERTIFICATION FORM FOR TIA STUDY PM

TRANSPORTATION IMPACT ASSESSMENT REPORTS

On 14 June 2017, the Council of the City of Ottawa adopted new Transportation Impact Assessment (TIA) Guidelines. In adopting the guidelines, Council established a requirement for those preparing and delivering transportation impact assessments and reports to sign a letter of certification.

Individuals submitting TIA reports will be responsible for all aspects of development-related transportation assessment and reporting, and undertaking such work, in accordance and compliance with the City of Ottawa's Official Plan, the Transportation Master Plan and the Transportation Impact Assessment (2017) Guidelines.

By submitting the attached TIA report (and any associated documents) and signing this document, the individual acknowledges that s/he meets the four criteria listed below.

CERTIFICATION

- I have reviewed and have a sound understanding of the objectives, needs and requirements of the City of Ottawa's Official Plan, Transportation Master Plan and the Transportation Impact Assessment (2017) Guidelines;
- I have a sound knowledge of industry standard practice with respect to the preparation of transportation impact assessment reports, including multi modal level of service review;
- I have substantial experience (more than 5 years) in undertaking and delivering transportation impact studies (analysis, reporting and geometric design) with strong background knowledge in transportation planning, engineering or traffic operations; and
- I am either a licensed¹ or registered² professional in good standing, whose field of expertise is either
 - Transportation engineering
 - Transportation planning

^{1,2} License of registration body that oversees the profession is required to have a code of conduct and ethics guidelines that will ensure appropriate conduct and representation for transportation planning and/or transportation engineering works.

Dated at Ottawa this 2 day of December, 2022
(City)

Name: Kimberley Hunton, P. Eng.

Professional Title: Project Manager, Transportation Planning

Signature of individual certifier that they meet the above criteria

OFFICE CONTACT INFORMATION

Address: 2611 Queensview Drive, Suite 300

City / Postal Code: Ottawa, ON K2B 8K2

Telephone / Extension: 613-690-1148

E-Mail Address: kimberley.hunton@wsp.com

STAMP





MEMO

TO: Neeti Paudel, P.Eng.
FROM: Kimberley Hunton, P.Eng.
SUBJECT: 864 Lady Ellen Place – Screening Form Explanation
DATE: December 2, 2022

The Screening Form has been prepared in support of the Site Plan Control Application for the proposed development at 864 Lady Ellen Place. The site is currently occupied by a three-storey general office building with a gross floor area of 3,529 m² and a large parking lot. The site area is 13,582 m² (1.3 ha or 3.3 acres) and is located at the north end of Lady Ellen Place in Ottawa, adjacent to the Highway 417 eastbound off-ramp at Carling/Kirkwood. As shown in **Figure 1**, the property currently has four access points at the northern end of Lady Ellen Place.



Figure 1: Site Location



The redevelopment of the site includes a one-storey self-storage building (1,750 m²) and a four-storey self-storage building (15,913 m²) with an estimated date of completion of 2024 and full occupancy date of 2025. Three of the existing access points will be maintained as ingress/egress points for the proposed development.

The Screening Form indicated that the trip generation trigger was satisfied due to the combined gross floor area of the two buildings exceeding the 5,000 m² required for an industrial development. However, given the expected land use change from general office to a self-storage warehouse, the anticipated number of trips during AM and PM peak hours are expected to be below the 60 peak hour person-trip threshold required to satisfy the trip generation trigger in the City of Ottawa’s 2017 Transportation Impact Assessment (TIA) Guidelines.

Moreover, when considering the demolition of the existing development and construction of the proposed development, there is a net reduction in future travel demand. Using the 11th Edition of the Institute of Transportation Engineers (ITE) Trip Generation Manual, the trips generated by the existing development (ITE Land Use Code 715 – Single Tenant Office Building) and for the proposed development (ITE Land Use Code 151 – Mini Warehouse) were calculated and are shown in **Table 1**.

Table 1: Reduction in Trips to 864 Lady Ellen Place

TRIPS	EXISTING DEVELOPMENT		PROPOSED DEVELOPMENT		NET DECREASE	
	AM PEAK HOUR	PM PEAK HOUR	AM PEAK HOUR	PM PEAK HOUR	AM PEAK HOUR	PM PEAK HOUR
Vehicle Trips	64	73	17	29	47	44
Person Trips	82	93	22	37	60	56

In accordance with the City of Ottawa’s TIA Guidelines, the ITE vehicle trips were multiplied by 1.28 to convert to person trips. As shown in **Table 1**, there is an expected reduction of 60 and 56 person trips during both the AM and PM peak hours when comparing the future to existing conditions.

With the reduction in person-trips it is put forward that the trip generation trigger is not satisfied. As neither the location nor the safety triggers were satisfied, the TIA study for the proposed development is considered complete.

Kimberley Hunton, P.Eng.
Manager, Transportation Planning

T +1 613-736-7200
T +1 613-690-1148 (Direct Line)
kimberley.hunton@wsp.com

City of Ottawa 2017 TIA Guidelines Screening Form

1. Description of Proposed Development

Municipal Address	
Description of Location	
Land Use Classification	
Development Size (units)	
Development Size (m ²)	
Number of Accesses and Locations	
Phase of Development	
Buildout Year	

If available, please attach a sketch of the development or site plan to this form.

2. Trip Generation Trigger

Considering the Development’s Land Use type and Size (as filled out in the previous section), please refer to the Trip Generation Trigger checks below.

Land Use Type	Minimum Development Size
Single-family homes	40 units
Townhomes or apartments	90 units
Office	3,500 m ²
Industrial	5,000 m ²
Fast-food restaurant or coffee shop	100 m ²
Destination retail	1,000 m ²
Gas station or convenience market	75 m ²

** If the development has a land use type other than what is presented in the table above, estimates of person-trip generation may be made based on average trip generation characteristics represented in the current edition of the Institute of Transportation Engineers (ITE) Trip Generation Manual.*

If the proposed development size is greater than the sizes identified above, the Trip Generation Trigger is satisfied.

Proposed Dev (ITE LUC: 151 Mini-Warehouse):
 AM Peak Hour: 17 vehicle trips
 PM Peak Hour: 29 vehicle trips

Existing Dev (ITE LUC: 715 Single-Tenant Office Space):
 AM Peak Hour: 64 vehicle trips
 PM Peak Hour: 73 vehicle trips

3. Location Triggers

	Yes	No
Does the development propose a new driveway to a boundary street that is designated as part of the City’s Transit Priority, Rapid Transit or Spine Bicycle Networks?		
Is the development in a Design Priority Area (DPA) or Transit-oriented Development (TOD) zone?*		

*DPA and TOD are identified in the City of Ottawa Official Plan (DPA in Section 2.5.1 and Schedules A and B; TOD in Annex 6). See Chapter 4 for a list of City of Ottawa Planning and Engineering documents that support the completion of TIA).

If any of the above questions were answered with ‘Yes,’ the Location Trigger is satisfied.

4. Safety Triggers

	Yes	No
Are posted speed limits on a boundary street are 80 km/hr or greater?		
Are there any horizontal/vertical curvatures on a boundary street limits sight lines at a proposed driveway?		
Is the proposed driveway within the area of influence of an adjacent traffic signal or roundabout (i.e. within 300 m of intersection in rural conditions, or within 150 m of intersection in urban/ suburban conditions)?		
Is the proposed driveway within auxiliary lanes of an intersection?		
Does the proposed driveway make use of an existing median break that serves an existing site?		
Is there is a documented history of traffic operations or safety concerns on the boundary streets within 500 m of the development?		
Does the development include a drive-thru facility?		

If any of the above questions were answered with ‘Yes,’ the Safety Trigger is satisfied.

5. Summary

	Yes	No
Does the development satisfy the Trip Generation Trigger?		
Does the development satisfy the Location Trigger?		
Does the development satisfy the Safety Trigger?		

If none of the triggers are satisfied, the TIA Study is complete. If one or more of the triggers is satisfied, the TIA Study must continue into the next stage (Screening and Scoping).

CONSULTANT - SUB CONSULTANT:								
CONSULTANT - SUB CONSULTANT:								
CONSULTANT - SUB CONSULTANT:								
CONSULTANT - SUB CONSULTANT:								
CONSULTANT - SUB CONSULTANT:								
CLIENT REF. #								
PROJECT:								
PROPOSED SELF-STORAGE LADY ELLEN PLACE								
KEY PLAN:								
DISCLAIMER:								
ISSUED FOR: -REVISION-								
<table border="1"> <thead> <tr> <th>NO.</th> <th>DATE</th> <th>ISSUED FOR</th> <th>DESCRIPTION</th> </tr> </thead> <tbody> <tr> <td>1</td> <td>11/02/2022</td> <td>ISSUED FOR BPA</td> <td></td> </tr> </tbody> </table>	NO.	DATE	ISSUED FOR	DESCRIPTION	1	11/02/2022	ISSUED FOR BPA	
NO.	DATE	ISSUED FOR	DESCRIPTION					
1	11/02/2022	ISSUED FOR BPA						
<table border="1"> <thead> <tr> <th>PROJECT NO.</th> <th>DATE</th> </tr> </thead> <tbody> <tr> <td>219-00038-09</td> <td>2022-11-04</td> </tr> </tbody> </table>	PROJECT NO.	DATE	219-00038-09	2022-11-04				
PROJECT NO.	DATE							
219-00038-09	2022-11-04							
<table border="1"> <thead> <tr> <th>DESIGNED BY:</th> <th>DESIGNED BY:</th> </tr> </thead> <tbody> <tr> <td>AH</td> <td>SG</td> </tr> </tbody> </table>	DESIGNED BY:	DESIGNED BY:	AH	SG				
DESIGNED BY:	DESIGNED BY:							
AH	SG							
<table border="1"> <thead> <tr> <th>CHECKED BY:</th> <th>CHECKED BY:</th> </tr> </thead> <tbody> <tr> <td>AH</td> <td>AH</td> </tr> </tbody> </table>	CHECKED BY:	CHECKED BY:	AH	AH				
CHECKED BY:	CHECKED BY:							
AH	AH							
<table border="1"> <thead> <tr> <th>DISCIPLINE:</th> <th>TITLE:</th> </tr> </thead> <tbody> <tr> <td>LANDSCAPE ARCHITECTURE</td> <td>SITE PLAN</td> </tr> </tbody> </table>	DISCIPLINE:	TITLE:	LANDSCAPE ARCHITECTURE	SITE PLAN				
DISCIPLINE:	TITLE:							
LANDSCAPE ARCHITECTURE	SITE PLAN							
<table border="1"> <thead> <tr> <th>SHEET NUMBER:</th> <th>SHEET #</th> <th>OF</th> <th>SHEET #</th> </tr> </thead> <tbody> <tr> <td>A100</td> <td></td> <td></td> <td></td> </tr> </tbody> </table>	SHEET NUMBER:	SHEET #	OF	SHEET #	A100			
SHEET NUMBER:	SHEET #	OF	SHEET #					
A100								
<table border="1"> <thead> <tr> <th>DATE OF:</th> <th>DATE OF:</th> </tr> </thead> <tbody> <tr> <td>2022-11-04</td> <td></td> </tr> </tbody> </table>	DATE OF:	DATE OF:	2022-11-04					
DATE OF:	DATE OF:							
2022-11-04								

LAYOUT NOTES:

- CONTRACTOR TO CONFIRM ALL DIMENSIONS AND REPORT ANY DISCREPANCIES TO CONTRACTOR ADMINISTRATOR PRIOR TO CONSTRUCTION
- LAYOUT TO BE APPROVED BY CONTRACT ADMINISTRATOR PRIOR TO ANY CONSTRUCTION OR REMOVALS
- ALL DIMENSIONS ARE IN METRIC UNLESS OTHERWISE NOTED
- CONTRACTOR IS RESPONSIBLE FOR ALL EXCAVATIONS, REMOVALS, DISPOSALS AND ROUGH GRADING AS REQUIRED TO CONSTRUCTION ALL WORKS AS SHOWN ON ALL PLANS, DETAILS AND SPECIFICATIONS
- LOCATION OF ALL UTILITIES SHOWN FOR ILLUSTRATION ONLY. CONTRACTOR MUST CONTACT ALL UTILITIES REGARDING RULES FOR WORKING IN THE AREA OF THE UTILITIES PRIOR TO COMMENCEMENT OF ANY WORK. CONTRACTOR MUST CONFIRM LOCATION OF ALL UTILITIES PRIOR TO CONSTRUCTION
- ALL EXISTING ROADS, SIDEWALKS, CURBS, FENCING, PAVING, SODDED AREAS, AND APPROACHES, ETC. TO REMAIN TO BE PROTECTED DURING CONSTRUCTION TO CONTRACT ADMINISTRATOR'S APPROVAL AT THE CONTRACTOR'S OWN COSTS.
- ALL EXISTING TREES, SHRUB BEDS, MULCH BEDS, AND SOD TO REMAIN TO BE PROTECTED DURING CONSTRUCTION. AREAS DAMAGED DURING CONSTRUCTION TO BE REPAIRED TO CONTRACT ADMINISTRATOR'S APPROVAL AT THE CONTRACTOR'S OWN COST.
- USE SPECIFIED BACKFILL IN ALL TRENCHES RUNNING BELOW ALL STRUCTURES, PAVING, WALKWAYS, ETC.
- FILL ALL HOLES AND LOW AREAS TO DESIGN SUBGRADE WITH COMPACTED FILL (SUITABLE TO SURFACE FINISH), FOR SODDED/PLANTED AREAS USE COMPACTED CLEAN EARTH FILL SUITABLE FOR PLANT GROWTH. FOR PAVED AREAS USE COMPACTED GRANULAR BASE.
- ALL TREES WITHIN OR IMMEDIATELY ADJACENT TO AREA OF WORK TO BE PROTECTED TO CITY OF OTTAWA TREE PROTECTION STANDARDS.

LEGEND:

- TOPSOIL AND SOD
- PLANT BED
- CONCRETE SIDEWALK
- HEAVY DUTY ASPHALT PAVEMENT
- LIGHT DUTY ASPHALT PAVEMENT
- PAINTED LINES
- SNOW REMOVAL AREA
- TOPSOIL AND NATIVE GRASS SEED MIX
- TOPSOIL AND DEEP ROOTING GRASS SEED MIX
- TOPSOIL AND POLLINATOR SEED MIX
- 3/4" RIVER STONE MULCH
- 2-4" RIVER STONE MULCH
- PROPERTY LINE
- EASEMENT LINE
- BUILDING OVERHANG
- EXISTING CHAINLINK FENCE
- APPROXIMATE AREA OF WORK
- EXISTING CURB
- NEW CURB
- ACCESSIBLE PARKING STALL

KEYNOTES:

- CONCRETE SIDEWALK. REFER TO DETAIL 4/L300
- ACCESSIBLE RAMP WITH TACTILE WARNING SURFACE INDICATOR (TWSI)
- 150mm HT CONCRETE CURB. REFER TO DETAIL 5/L300
- ASPHALT PARKING LOT. REFER TO CIVIL FOR DETAIL.
- TYPE A PARKING STALL
- TYPE B PARKING STALL
- PROPOSED GARBAGE ENCLOSURE. REFER TO DETAIL 11/L300
- SNOW REMOVAL STORAGE AREA
- EXISTING FIRE HYDRANT
- 3/4" RIVER STONE MULCH.
- 2-4" RIVER STONE MULCH.
- 316 STAINLESS STEEL BICYCLE RACKS. REFER TO DETAIL 10/L300
- SODDED AREA. REFER TO DETAIL 6/L300
- PAINTED CROSSWALK
- PAINTED ISLAND
- SIGNAGE
- LOADING SPACE
- SEEDED AREA. REFER TO DETAIL 6/L300

PARKING REQUIREMENTS:

- WAREHOUSE:
 0.4 PER 100m² FOR THE FIRST 5000m² GROSS FLOOR AREA,
 0.4 PER 100m² ABOVE 5000m² GROSS FLOOR AREA
 = 71 SPACES
 - ACCESSIBLE PARKING REQ.:
 1 TYPE A
 2 TYPE B
- TOTAL PARKING PROVIDED:
 74 SPACES PROVIDED
 7 LOADING SPACES PROVIDED (3 REQ.)
- BICYCLE PARKING:
 1 STALL PER 2000m² GROSS FLOOR AREA
 10 SPACES PROVIDED (9 REQ.)

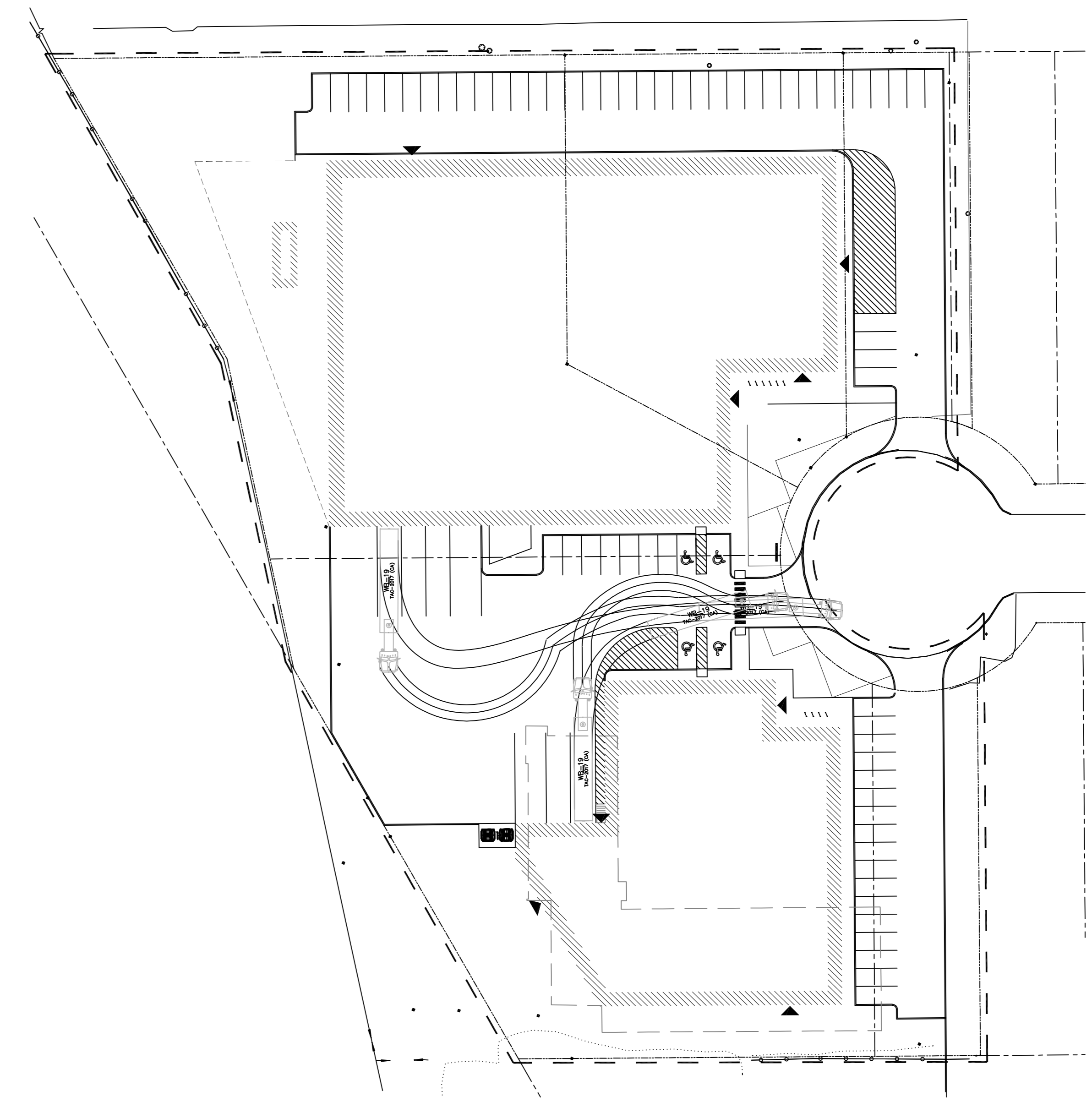

1 VEHICLE TURNING MOVEMENTS
 L100 1:500

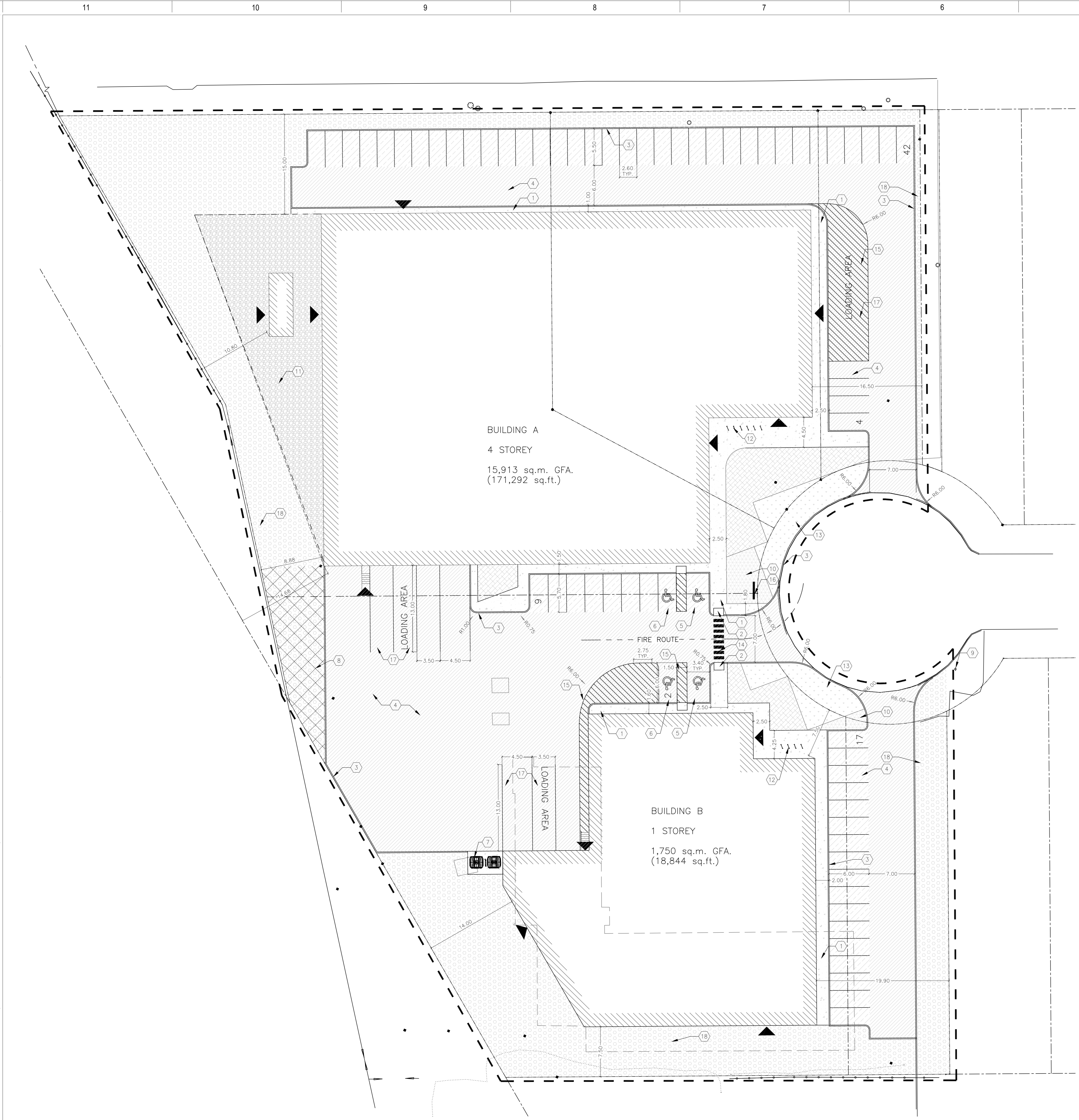

1 SITE PLAN
 L100 1:250

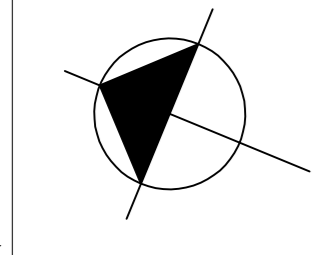

1 SITE PLAN
 L100 1:250

APPENDIX

C SAMPLE CALCULATIONS

Point Sources

Name	ID	Result. PWL			Lw / Li		Correction			Operating Time				K0	Height (m)	Coordinates		
		Day (dBA)	Evening (dBA)	Night (dBA)	Type	Value	norm. dB(A)	Day dB(A)	Evening dB(A)	Night dB(A)	Day / Eve (min)	Night (min)	(dB)	X (m)		Y (m)	Z (m)	
HVAC 10T Unit	SS_BLDA_HVAC_04	79.9	79.9	79.9	Lw	York_10T		0	0	0	60	60	0	1.8	g	441843	5025421	100.8
HVAC 10T Unit	SS_BLDA_HVAC_02	79.9	79.9	79.9	Lw	York_10T		0	0	0	60	60	0	1.8	g	441852.1	5025442	100.8
HVAC 10T Unit	SS_BLDA_HVAC_05	79.9	79.9	79.9	Lw	York_10T		0	0	0	60	60	0	1.8	g	441859.8	5025427	100.8
HVAC 10T Unit	SS_BLDA_HVAC_03	79.9	79.9	79.9	Lw	York_10T		0	0	0	60	60	0	1.8	g	441867.9	5025449	100.8
HVAC 10T Unit	SS_BLDA_HVAC_01	79.9	79.9	79.9	Lw	York_10T		0	0	0	60	60	0	1.8	g	441837.9	5025437	100.8
HVAC 10T Unit	SS_BLDA_HVAC_07	79.9	79.9	79.9	Lw	York_10T		0	0	0	60	60	0	1.8	g	441847.5	5025407	100.8
HVAC 10T Unit	SS_BLDA_HVAC_11	79.9	79.9	79.9	Lw	York_10T		0	0	0	60	60	0	1.8	g	441873.7	5025390	100.8
HVAC 10T Unit	SS_BLDA_HVAC_06	79.9	79.9	79.9	Lw	York_10T		0	0	0	60	60	0	1.8	g	441875.3	5025433	100.8
HVAC 10T Unit	SS_BLDA_HVAC_08	79.9	79.9	79.9	Lw	York_10T		0	0	0	60	60	0	1.8	g	441864.5	5025408	100.8
HVAC 10T Unit	SS_BLDA_HVAC_09	79.9	79.9	79.9	Lw	York_10T		0	0	0	60	60	0	1.8	g	441884.4	5025413	100.8
HVAC 10T Unit	SS_BLDB_HVAC_03	79.9	79.9	79.9	Lw	York_10T		0	0	0	60	60	0	1.8	g	441817.1	5025375	87.29
HVAC 10T Unit	SS_BLDA_HVAC_12	79.9	79.9	79.9	Lw	York_10T		0	0	0	60	60	0	1.8	g	441892.5	5025396	100.8
HVAC 10T Unit	SS_BLDA_HVAC_10	79.9	79.9	79.9	Lw	York_10T		0	0	0	60	60	0	1.8	g	441877.9	5025402	100.8
HVAC 10T Unit	SS_BLDB_HVAC_02	79.9	79.9	79.9	Lw	York_10T		0	0	0	60	60	0	1.8	g	441800.3	5025370	87.29
HVAC 10T Unit	SS_BLDB_HVAC_01	79.9	79.9	79.9	Lw	York_10T		0	0	0	60	60	0	1.8	g	441784	5025363	87.29
Trailer unloading - Forklift	IM_FKLF_03	99.7	99.7	99.7	Lw	FL_imp		0	0	0	60	0	0	1.8	r	441796.2	5025397	79.79
Trailer unloading - Forklift at Building A	IM_FKLF_02	99.7	99.7	99.7	Lw	FL_imp		0	0	0	60	0	0	1.8	r	441898.6	5025390	79.18
Trailer unloading - Forklift - Building A	IM_FKLF_01	99.7	99.7	99.7	Lw	FL_imp		0	0	0	60	0	0	1.8	r	441826.7	5025429	79.63
Truck Idling at Loading Bay - Bldg B	SS_TRKI_03	98.5	98.5	98.5	Lw	HTRK_IDLE		0	0	0	5	0	0	2.4	r	441801.3	5025399	80.32
Truck Idling at Loading Bay - Bldg A	SS_TRKI_02	98.5	98.5	98.5	Lw	HTRK_IDLE		0	0	0	5	0	0	2.4	r	441822.7	5025427	80.29
Truck Idling at Loading Bay - Bldg A	SS_TRKI_01	98.5	98.5	98.5	Lw	HTRK_IDLE		0	0	0	5	0	0	2.4	r	441900	5025386	79.86

Line Sources

Name	ID	Result. PWL		Result. PWL'		Lw / Li			Correction			K0	Moving Pt. Src		
		Day/Eve (dBA)	Night (dBA)	Day/Eve (dBA)	Night (dBA)	Type	Value	norm. dB(A)	Day dB(A)	Evening dB(A)	Night dB(A)	(dB)	Day/Eve Number	Night Number	Speed (km/h)
Truck Movement to Building B	SS_TRKM_01	93.1	-18.4	71.8	-39.7	PWL-Pt	HTRK_MOV		0	0	0	0	14	0	15
Truck Movement to Building A (South Side)	SS_TRKM_03	87.9	-20.5	68.7	-39.7	PWL-Pt	HTRK_MOV		0	0	0	0	7	0	15
Truck Movement to Building A (North Side)	SS_TRKM_02	90.4	-18.6	69.3	-39.7	PWL-Pt	HTRK_MOV		0	0	0	0	8	0	15

Sound Power Spectra

Name	ID	Type	1/3 Oktave Spectrum (dB)											Source	
			Weight.	31.5	63	125	250	500	1000	2000	4000	8000	A		lin
Large Trucks Delivery	HTRK_MOV	Lw		91	101	101	98	98	97	96	90	86	102.1	106.9	WSP Database
Large Trucks Idling	HTRK_IDLE	Lw		90	101	101	96	96	94	90	86	76	98.5	105.8	WSP Database
10 Ton HVAC Unit	York_10T	Lw	A			73	74	75	72	66	60	50	79.9	90.3	York KDB122 Specs
Forklift	FL_imp	Lw		99.5	102.5	103.5	100.5	97.5	92.5	90.5	89.5	83.5	99.7	108.4	WSP Database

Receptor Locations

Name	ID	Level Lr		Limit. Value		Height (m)	Coordinates		
		Day/Eve	Night	Day/Eve	Night		X	Y	Z
		(dBA)	(dBA)	(dBA)	(dBA)		(m)	(m)	(m)
R01_PW	R01_PW	36.1	31.6	50	45	5.5	442021.47	5025430	82.3
R02_PW	R02_PW	37	32.7	50	45	5.5	442032.89	5025402	82.57
R03_PW	R03_PW	39.3	33.1	50	45	5.5	442044.57	5025373	83.44
R04_PW	R04_PW	40.5	32.6	50	45	5.5	442055.72	5025346	84.42
R05_PW	R05_PW	39.5	31.3	50	45	4.5	442056.59	5025292	84.6
R06_PW	R06_PW	39.4	31.4	50	45	4.5	441995.84	5025252	84.93
R07_PW	R07_PW	35.6	31.8	50	45	4.5	441965.54	5025236	85.36
R08_PW	R08_PW	40.3	32.2	50	45	4.5	441912.73	5025204	85.5
R09_PW	R09_PW	29.7	28.9	50	45	4.5	441844.9	5025162	85.5

Sample CADNA/A Calculation at Receptor

Receiver

Name: R01_PW
 ID: R01_PW
 X: 442021.47 m
 Y: 5025429.82 m
 Z: 82.30 m

Point Source, ISO 9613, Name: "Truck Idling at Loading Bay - Bldg A", ID: "SS_TRKI_01"

Nr.	X (m)	Y (m)	Z (m)	Refl.	DEN	Freq. (Hz)	Lw dB(A)	l/a dB	Optime dB	K0 (dB)	Di (dB)	Adiv (dB)	Aatm (dB)	Agr (dB)	Afol (dB)	Ahous (dB)	Abar (dB)	Cmet (dB)	RL (dB)	Lr dB(A)
1	441899.98	5025386.19	79.86	0	D	A	98.5	0.0	-10.8	0.0	0.0	53.2	0.7	-3.0	0.0	0.0	5.5	0.0	0.0	31.3

Point Source, ISO 9613, Name: "HVAC 10T Unit", ID: "SS_BLDA_HVAC_12"

Nr.	X (m)	Y (m)	Z (m)	Refl.	DEN	Freq. (Hz)	Lw dB(A)	l/a dB	Optime dB	K0 (dB)	Di (dB)	Adiv (dB)	Aatm (dB)	Agr (dB)	Afol (dB)	Ahous (dB)	Abar (dB)	Cmet (dB)	RL (dB)	Lr dB(A)
2	441892.47	5025396.01	100.80	0	D	A	79.9	0.0	0.0	0.0	0.0	53.6	0.3	-3.0	0.0	0.0	8.3	0.0	0.0	20.7
2	441892.47	5025396.01	100.80	0	N	A	79.9	0.0	0.0	0.0	0.0	53.6	0.3	-3.0	0.0	0.0	8.3	0.0	0.0	20.7
3	441892.47	5025396.01	100.80	1	D	A	79.9	0.0	0.0	0.0	0.0	56.3	0.4	-3.0	0.0	0.0	9.5	0.0	2.0	14.7
3	441892.47	5025396.01	100.80	1	N	A	79.9	0.0	0.0	0.0	0.0	56.3	0.4	-3.0	0.0	0.0	9.5	0.0	2.0	14.7

Point Source, ISO 9613, Name: "HVAC 10T Unit", ID: "SS_BLDA_HVAC_09"

Nr.	X (m)	Y (m)	Z (m)	Refl.	DEN	Freq. (Hz)	Lw dB(A)	l/a dB	Optime dB	K0 (dB)	Di (dB)	Adiv (dB)	Aatm (dB)	Agr (dB)	Afol (dB)	Ahous (dB)	Abar (dB)	Cmet (dB)	RL (dB)	Lr dB(A)
4	441884.39	5025413.28	100.80	0	D	A	79.9	0.0	0.0	0.0	0.0	53.9	0.3	-3.0	0.0	0.0	8.3	0.0	0.0	20.5
4	441884.39	5025413.28	100.80	0	N	A	79.9	0.0	0.0	0.0	0.0	53.9	0.3	-3.0	0.0	0.0	8.3	0.0	0.0	20.5
6	441884.39	5025413.28	100.80	1	D	A	79.9	0.0	0.0	0.0	0.0	58.2	0.5	-3.0	0.0	0.0	13.2	0.0	2.0	9.0
6	441884.39	5025413.28	100.80	1	N	A	79.9	0.0	0.0	0.0	0.0	58.2	0.5	-3.0	0.0	0.0	13.2	0.0	2.0	9.0

Point Source, ISO 9613, Name: "HVAC 10T Unit", ID: "SS_BLDA_HVAC_06"

Nr.	X (m)	Y (m)	Z (m)	Refl.	DEN	Freq. (Hz)	Lw dB(A)	l/a dB	Optime dB	K0 (dB)	Di (dB)	Adiv (dB)	Aatm (dB)	Agr (dB)	Afol (dB)	Ahous (dB)	Abar (dB)	Cmet (dB)	RL (dB)	Lr dB(A)
8	441875.30	5025432.72	100.80	0	D	A	79.9	0.0	0.0	0.0	0.0	54.4	0.3	-3.0	0.0	0.0	8.1	0.0	0.0	20.1
8	441875.30	5025432.72	100.80	0	N	A	79.9	0.0	0.0	0.0	0.0	54.4	0.3	-3.0	0.0	0.0	8.1	0.0	0.0	20.1
13	441875.30	5025432.72	100.80	1	D	A	79.9	0.0	0.0	0.0	0.0	58.3	0.5	-3.0	0.0	0.0	9.6	0.0	2.0	12.5
13	441875.30	5025432.72	100.80	1	N	A	79.9	0.0	0.0	0.0	0.0	58.3	0.5	-3.0	0.0	0.0	9.6	0.0	2.0	12.5

Point Source, ISO 9613, Name: "HVAC 10T Unit", ID: "SS_BLDA_HVAC_10"

Nr.	X (m)	Y (m)	Z (m)	Refl.	DEN	Freq. (Hz)	Lw dB(A)	l/a dB	Optime dB	K0 (dB)	Di (dB)	Adiv (dB)	Aatm (dB)	Agr (dB)	Afol (dB)	Ahous (dB)	Abar (dB)	Cmet (dB)	RL (dB)	Lr dB(A)
20	441877.90	5025401.89	100.80	0	D	A	79.9	0.0	0.0	0.0	0.0	54.4	0.3	-3.0	0.0	0.0	8.4	0.0	0.0	19.8
20	441877.90	5025401.89	100.80	0	N	A	79.9	0.0	0.0	0.0	0.0	54.4	0.3	-3.0	0.0	0.0	8.4	0.0	0.0	19.8
26	441877.90	5025401.89	100.80	1	D	A	79.9	0.0	0.0	0.0	0.0	55.9	0.4	-3.0	0.0	0.0	9.2	0.0	2.0	15.4
26	441877.90	5025401.89	100.80	1	N	A	79.9	0.0	0.0	0.0	0.0	55.9	0.4	-3.0	0.0	0.0	9.2	0.0	2.0	15.4

Point Source, ISO 9613, Name: "HVAC 10T Unit", ID: "SS_BLDA_HVAC_11"

Nr.	X (m)	Y (m)	Z (m)	Refl.	DEN	Freq. (Hz)	Lw dB(A)	l/a dB	Optime dB	K0 (dB)	Di (dB)	Adiv (dB)	Aatm (dB)	Agr (dB)	Afol (dB)	Ahous (dB)	Abar (dB)	Cmet (dB)	RL (dB)	Lr dB(A)
30	441873.70	5025389.67	100.80	0	D	A	79.9	0.0	0.0	0.0	0.0	54.8	0.3	-3.0	0.0	0.0	8.8	0.0	0.0	19.0
30	441873.70	5025389.67	100.80	0	N	A	79.9	0.0	0.0	0.0	0.0	54.8	0.3	-3.0	0.0	0.0	8.8	0.0	0.0	19.0
33	441873.70	5025389.67	100.80	1	D	A	79.9	0.0	0.0	0.0	0.0	55.4	0.4	-3.0	0.0	0.0	9.1	0.0	2.0	16.1
33	441873.70	5025389.67	100.80	1	N	A	79.9	0.0	0.0	0.0	0.0	55.4	0.4	-3.0	0.0	0.0	9.1	0.0	2.0	16.1

Point Source, ISO 9613, Name: "HVAC 10T Unit", ID: "SS_BLDA_HVAC_03"

Nr.	X (m)	Y (m)	Z (m)	Refl.	DEN	Freq. (Hz)	Lw dB(A)	l/a dB	Optime dB	K0 (dB)	Di (dB)	Adiv (dB)	Aatm (dB)	Agr (dB)	Afol (dB)	Ahous (dB)	Abar (dB)	Cmet (dB)	RL (dB)	Lr dB(A)
49	441867.85	5025448.56	100.80	0	D	A	79.9	0.0	0.0	0.0	0.0	54.9	0.3	-3.0	0.0	0.0	7.8	0.0	0.0	19.9
49	441867.85	5025448.56	100.80	0	N	A	79.9	0.0	0.0	0.0	0.0	54.9	0.3	-3.0	0.0	0.0	7.8	0.0	0.0	19.9
69	441867.85	5025448.56	100.80	1	D	A	79.9	0.0	0.0	0.0	0.0	58.5	0.5	-3.0	0.0	0.0	9.4	0.0	2.0	12.5
69	441867.85	5025448.56	100.80	1	N	A	79.9	0.0	0.0	0.0	0.0	58.5	0.5	-3.0	0.0	0.0	9.4	0.0	2.0	12.5

Point Source, ISO 9613, Name: "HVAC 10T Unit", ID: "SS_BLDA_HVAC_08"

Nr.	X (m)	Y (m)	Z (m)	Refl.	DEN	Freq. (Hz)	Lw dB(A)	l/a dB	Optime dB	K0 (dB)	Di (dB)	Adiv (dB)	Aatm (dB)	Agr (dB)	Afol (dB)	Ahous (dB)	Abar (dB)	Cmet (dB)	RL (dB)	Lr dB(A)
79	441864.45	5025407.53	100.80	0	D	A	79.9	0.0	0.0	0.0	0.0	55.1	0.3	-3.0	0.0	0.0	8.7	0.0	0.0	18.8

Point Source, ISO 9613, Name: "HVAC 10T Unit", ID: "SS_BLDA_HVAC_08"																				
Nr.	X	Y	Z	Refl.	DEN	Freq.	Lw	l/a	Optime	K0	Di	Adiv	Aatm	Agr	Afol	Ahous	Abar	Cmet	RL	Lr
	(m)	(m)	(m)			(Hz)	dB(A)	dB	dB	(dB)	(dB)	(dB)	(dB)	(dB)	(dB)	(dB)	(dB)	(dB)	(dB)	dB(A)
79	441864.45	5025407.53	100.80	0	N	A	79.9	0.0	0.0	0.0	0.0	55.1	0.3	-3.0	0.0	0.0	8.7	0.0	0.0	18.8
87	441864.45	5025407.53	100.80	1	D	A	79.9	0.0	0.0	0.0	0.0	57.4	0.4	-3.0	0.0	0.0	9.6	0.0	2.0	13.4
87	441864.45	5025407.53	100.80	1	N	A	79.9	0.0	0.0	0.0	0.0	57.4	0.4	-3.0	0.0	0.0	9.6	0.0	2.0	13.4

Point Source, ISO 9613, Name: "HVAC 10T Unit", ID: "SS_BLDA_HVAC_05"																				
Nr.	X	Y	Z	Refl.	DEN	Freq.	Lw	l/a	Optime	K0	Di	Adiv	Aatm	Agr	Afol	Ahous	Abar	Cmet	RL	Lr
	(m)	(m)	(m)			(Hz)	dB(A)	dB	dB	(dB)	(dB)	(dB)	(dB)	(dB)	(dB)	(dB)	(dB)	(dB)	(dB)	dB(A)
95	441859.79	5025426.88	100.80	0	D	A	79.9	0.0	0.0	0.0	0.0	55.2	0.3	-3.0	0.0	0.0	8.5	0.0	0.0	18.8
95	441859.79	5025426.88	100.80	0	N	A	79.9	0.0	0.0	0.0	0.0	55.2	0.3	-3.0	0.0	0.0	8.5	0.0	0.0	18.8
103	441859.79	5025426.88	100.80	1	D	A	79.9	0.0	0.0	0.0	0.0	57.7	0.5	-3.0	0.0	0.0	9.5	0.0	2.0	13.2
103	441859.79	5025426.88	100.80	1	N	A	79.9	0.0	0.0	0.0	0.0	57.7	0.5	-3.0	0.0	0.0	9.5	0.0	2.0	13.2

Point Source, ISO 9613, Name: "HVAC 10T Unit", ID: "SS_BLDA_HVAC_02"																				
Nr.	X	Y	Z	Refl.	DEN	Freq.	Lw	l/a	Optime	K0	Di	Adiv	Aatm	Agr	Afol	Ahous	Abar	Cmet	RL	Lr
	(m)	(m)	(m)			(Hz)	dB(A)	dB	dB	(dB)	(dB)	(dB)	(dB)	(dB)	(dB)	(dB)	(dB)	(dB)	(dB)	dB(A)
106	441852.11	5025442.31	100.80	0	D	A	79.9	0.0	0.0	0.0	0.0	55.7	0.4	-3.0	0.0	0.0	8.3	0.0	0.0	18.6
106	441852.11	5025442.31	100.80	0	N	A	79.9	0.0	0.0	0.0	0.0	55.7	0.4	-3.0	0.0	0.0	8.3	0.0	0.0	18.6
127	441852.11	5025442.31	100.80	1	D	A	79.9	0.0	0.0	0.0	0.0	57.9	0.5	-3.0	0.0	0.0	9.3	0.0	2.0	13.2
127	441852.11	5025442.31	100.80	1	N	A	79.9	0.0	0.0	0.0	0.0	57.9	0.5	-3.0	0.0	0.0	9.3	0.0	2.0	13.2
135	441852.11	5025442.31	100.80	1	D	A	79.9	0.0	0.0	0.0	0.0	56.0	0.4	-3.0	0.0	0.0	8.2	0.0	2.0	16.3
135	441852.11	5025442.31	100.80	1	N	A	79.9	0.0	0.0	0.0	0.0	56.0	0.4	-3.0	0.0	0.0	8.2	0.0	2.0	16.3

Line Source, ISO 9613, Name: "Truck Movement to Building A (South Side)", ID: "SS_TRKM_03"																				
Nr.	X	Y	Z	Refl.	DEN	Freq.	Lw	l/a	Optime	K0	Di	Adiv	Aatm	Agr	Afol	Ahous	Abar	Cmet	RL	Lr
	(m)	(m)	(m)			(Hz)	dB(A)	dB	dB	(dB)	(dB)	(dB)	(dB)	(dB)	(dB)	(dB)	(dB)	(dB)	(dB)	dB(A)
142	441865.03	5025374.61	79.81	0	D	A	68.7	0.7	0.0	0.0	0.0	55.4	1.1	-3.0	0.0	0.0	4.8	0.0	0.0	11.1
144	441869.55	5025376.50	79.81	0	D	A	68.7	9.4	0.0	0.0	0.0	55.1	1.1	-3.0	0.0	0.0	4.8	0.0	0.0	20.1
146	441874.44	5025378.55	79.81	0	D	A	68.7	2.9	0.0	0.0	0.0	54.8	1.1	-3.0	0.0	0.0	4.8	0.0	0.0	13.9
157	441876.59	5025379.45	79.81	0	D	A	68.7	4.3	0.0	0.0	0.0	54.7	1.1	-3.0	0.0	0.0	4.8	0.0	0.0	15.5
164	441879.74	5025380.77	79.81	0	D	A	68.7	6.2	0.0	0.0	0.0	54.5	1.1	-3.0	0.0	0.0	4.8	0.0	0.0	17.5
177	441883.98	5025382.55	79.81	0	D	A	68.7	7.1	0.0	0.0	0.0	54.3	1.0	-3.0	0.0	0.0	4.9	0.0	0.0	18.6
180	441888.36	5025384.38	79.81	0	D	A	68.7	6.5	0.0	0.0	0.0	54.0	1.0	-3.0	0.0	0.0	5.0	0.0	0.0	18.2
188	441892.00	5025385.90	79.80	0	D	A	68.7	5.4	0.0	0.0	0.0	53.7	1.0	-3.0	0.0	0.0	5.2	0.0	0.0	17.2
191	441894.64	5025387.01	79.80	0	D	A	68.7	3.6	0.0	0.0	0.0	53.5	1.0	-3.0	0.0	0.0	5.4	0.0	0.0	15.4
192	441896.84	5025387.93	79.80	0	D	A	68.7	4.0	0.0	0.0	0.0	53.4	0.9	-3.0	0.0	0.0	5.6	0.0	0.0	15.8
206	441898.96	5025388.82	79.80	0	D	A	68.7	3.3	0.0	0.0	0.0	53.2	0.9	-3.0	0.0	0.0	5.8	0.0	0.0	15.1
215	441865.84	5025374.95	79.81	1	D	A	68.7	4.6	0.0	0.0	0.0	55.4	1.1	-3.0	0.0	0.0	4.8	0.0	17.3	-2.2
233	441867.87	5025375.80	79.81	1	D	A	68.7	1.8	0.0	0.0	0.0	55.3	1.1	-3.0	0.0	0.0	4.8	0.0	17.3	-4.9
239	441869.21	5025376.36	79.81	1	D	A	68.7	1.5	0.0	0.0	0.0	55.2	1.1	-3.0	0.0	0.0	4.8	0.0	17.2	-5.1
242	441871.24	5025377.21	79.81	1	D	A	68.7	4.7	0.0	0.0	0.0	55.1	1.1	-3.0	0.0	0.0	4.8	0.0	17.2	-1.7
245	441873.10	5025377.99	79.81	1	D	A	68.7	0.3	0.0	0.0	0.0	54.9	1.1	-3.0	0.0	0.0	4.8	0.0	17.1	-6.0
247	441874.14	5025378.42	79.81	1	D	A	68.7	0.8	0.0	0.0	0.0	54.9	1.1	-3.0	0.0	0.0	4.8	0.0	17.1	-5.4
260	441875.48	5025378.99	79.81	1	D	A	68.7	2.4	0.0	0.0	0.0	54.8	1.1	-3.0	0.0	0.0	4.8	0.0	17.1	-3.7
279	441876.48	5025379.40	79.81	1	D	A	68.7	-3.6	0.0	0.0	0.0	54.7	1.1	-3.0	0.0	0.0	4.8	0.0	17.1	-9.5
365	441893.57	5025377.59	79.97	0	D	A	68.7	13.2	0.0	0.0	0.0	53.8	1.0	-3.0	0.0	0.0	5.0	0.0	0.0	25.2
370	441876.93	5025370.50	79.96	0	D	A	68.7	11.8	0.0	0.0	0.0	54.9	1.1	-3.0	0.0	0.0	4.8	0.0	0.0	22.8
2972	441900.19	5025388.66	79.82	0	D	A	68.7	0.9	0.0	0.0	0.0	53.2	0.9	-3.0	0.0	0.0	5.9	0.0	0.0	12.7
2980	441900.67	5025387.59	79.84	0	D	A	68.7	0.5	0.0	0.0	0.0	53.1	0.9	-3.0	0.0	0.0	5.8	0.0	0.0	12.3
2988	441901.11	5025386.60	79.86	0	D	A	68.7	0.2	0.0	0.0	0.0	53.1	0.9	-3.0	0.0	0.0	5.8	0.0	0.0	12.1
2996	441901.57	5025385.57	79.89	0	D	A	68.7	0.8	0.0	0.0	0.0	53.1	0.9	-3.0	0.0	0.0	5.7	0.0	0.0	12.7
3003	441902.02	5025384.55	79.91	0	D	A	68.7	0.1	0.0	0.0	0.0	53.1	0.9	-3.0	0.0	0.0	5.7	0.0	0.0	12.1
3011	441902.44	5025383.61	79.94	0	D	A	68.7	0.1	0.0	0.0	0.0	53.1	0.9	-3.0	0.0	0.0	5.7	0.0	0.0	12.2
3018	441902.87	5025382.64	79.96	0	D	A	68.7	0.3	0.0	0.0	0.0	53.1	0.9	-3.0	0.0	0.0	5.6	0.0	0.0	12.4
3026	441903.18	5025381.94	79.98	0	D	A	68.7	-3.3	0.0	0.0	0.0	53.1	0.9	-3.0	0.0	0.0	5.6	0.0	0.0	8.8

Point Source, ISO 9613, Name: "HVAC 10T Unit", ID: "SS_BLDA_HVAC_07"																				
Nr.	X	Y	Z	Refl.	DEN	Freq.	Lw	l/a	Optime	K0	Di	Adiv	Aatm	Agr	Afol	Ahous	Abar	Cmet	RL	Lr
	(m)	(m)	(m)			(Hz)	dB(A)	dB	dB	(dB)	(dB)	(dB)	(dB)	(dB)	(dB)	(dB)	(dB)	(dB)	(dB)	dB(A)
342	441847.54	5025406.88	100.80	0	D	A	79.9	0.0	0.0	0.0	0.0	55.9	0.4	-3.0	0.0	0.0	9.1	0.0	0.0	17.5
342	441847.54	5025406.88	100.80	0	N	A	79.9	0.0	0.0	0.0	0.0	55.9	0.4	-3.0	0.0	0.0	9.1	0.0	0.0	17.5
345	441847.54	5025406.88	100.80	1	D	A	79.9	0.0	0.0	0.0	0.0	56.8	0.4	-3.0	0.0	0.0	9.4	0.0	2.0	14.3
345	441847.54	5025406.88	100.80	1	N	A	79.9	0.0	0.0	0.0	0.0	56.8	0.4	-3.0	0.0	0.0	9.4	0.0	2.0	14.3

Sample CADNA/A Calculation at Receptor

Point Source, ISO 9613, Name: "HVAC 10T Unit", ID: "SS_BLDA_HVAC_04"																				
Nr.	X	Y	Z	Refl.	DEN	Freq.	Lw	l/a	Optime	K0	Di	Adiv	Aatm	Agr	Afol	Ahous	Abar	Cmet	RL	Lr
	(m)	(m)	(m)			(Hz)	dB(A)	dB	dB	(dB)	(dB)	(dB)	(dB)	(dB)	(dB)	(dB)	(dB)	(dB)	(dB)	dB(A)
377	441842.99	5025420.89	100.80	0	D	A	79.9	0.0	0.0	0.0	0.0	56.1	0.4	-3.0	0.0	0.0	8.9	0.0	0.0	17.5
377	441842.99	5025420.89	100.80	0	N	A	79.9	0.0	0.0	0.0	0.0	56.1	0.4	-3.0	0.0	0.0	8.9	0.0	0.0	17.5
380	441842.99	5025420.89	100.80	1	D	A	79.9	0.0	0.0	0.0	0.0	57.0	0.4	-3.0	0.0	0.0	9.3	0.0	2.0	14.1
380	441842.99	5025420.89	100.80	1	N	A	79.9	0.0	0.0	0.0	0.0	57.0	0.4	-3.0	0.0	0.0	9.3	0.0	2.0	14.1
387	441842.99	5025420.89	100.80	1	D	A	79.9	0.0	0.0	0.0	0.0	57.1	0.4	-3.0	0.0	0.0	8.4	0.0	2.0	15.0
387	441842.99	5025420.89	100.80	1	N	A	79.9	0.0	0.0	0.0	0.0	57.1	0.4	-3.0	0.0	0.0	8.4	0.0	2.0	15.0

Line Source, ISO 9613, Name: "Truck Movement to Building B", ID: "SS_TRKM_01"																				
Nr.	X	Y	Z	Refl.	DEN	Freq.	Lw	l/a	Optime	K0	Di	Adiv	Aatm	Agr	Afol	Ahous	Abar	Cmet	RL	Lr
	(m)	(m)	(m)			(Hz)	dB(A)	dB	dB	(dB)	(dB)	(dB)	(dB)	(dB)	(dB)	(dB)	(dB)	(dB)	(dB)	dB(A)
398	441841.13	5025376.10	79.72	0	D	A	71.8	0.5	0.0	0.0	0.0	56.5	1.3	-3.0	0.0	0.0	23.0	0.0	0.0	-5.5
405	441840.57	5025377.55	79.73	0	D	A	71.8	3.0	0.0	0.0	0.0	56.5	1.3	-3.0	0.0	0.0	23.1	0.0	0.0	-3.1
416	441840.03	5025378.97	79.74	0	D	A	71.8	0.2	0.0	0.0	0.0	56.5	1.3	-3.0	0.0	0.0	23.2	0.0	0.0	-6.0
432	441839.66	5025379.94	79.75	0	D	A	71.8	0.2	0.0	0.0	0.0	56.5	1.3	-3.0	0.0	0.0	23.2	0.0	0.0	-6.1
455	441839.28	5025380.94	79.75	0	D	A	71.8	0.5	0.0	0.0	0.0	56.5	1.3	-3.0	0.0	0.0	23.3	0.0	0.0	-5.9
466	441838.87	5025382.01	79.76	0	D	A	71.8	0.7	0.0	0.0	0.0	56.5	1.3	-3.0	0.0	0.0	23.4	0.0	0.0	-5.7
476	441838.45	5025383.09	79.77	0	D	A	71.8	0.6	0.0	0.0	0.0	56.5	1.3	-3.0	0.0	0.0	23.4	0.0	0.0	-5.9
482	441838.03	5025384.18	79.77	0	D	A	71.8	0.8	0.0	0.0	0.0	56.5	1.3	-3.0	0.0	0.0	23.6	0.0	0.0	-5.9
488	441837.40	5025385.83	79.78	0	D	A	71.8	3.7	0.0	0.0	0.0	56.5	1.3	-3.0	0.0	0.0	23.7	0.0	0.0	-3.1
494	441836.79	5025387.41	79.79	0	D	A	71.8	0.2	0.0	0.0	0.0	56.6	1.3	-3.0	0.0	0.0	23.8	0.0	0.0	-6.7
500	441836.42	5025388.39	79.80	0	D	A	71.8	0.2	0.0	0.0	0.0	56.6	1.3	-3.0	0.0	0.0	23.8	0.0	0.0	-6.7
512	441836.04	5025389.38	79.80	0	D	A	71.8	0.3	0.0	0.0	0.0	56.6	1.3	-3.0	0.0	0.0	23.9	0.0	0.0	-6.6
518	441835.65	5025390.39	79.81	0	D	A	71.8	0.3	0.0	0.0	0.0	56.6	1.3	-3.0	0.0	0.0	23.9	0.0	0.0	-6.7
527	441835.24	5025391.47	79.82	0	D	A	71.8	1.0	0.0	0.0	0.0	56.6	1.3	-3.0	0.0	0.0	24.0	0.0	0.0	-6.1
534	441834.81	5025392.58	79.82	0	D	A	71.8	0.5	0.0	0.0	0.0	56.6	1.3	-3.0	0.0	0.0	24.0	0.0	0.0	-6.7
545	441834.42	5025393.60	79.83	0	D	A	71.8	0.3	0.0	0.0	0.0	56.6	1.3	-3.0	0.0	0.0	24.1	0.0	0.0	-6.9
557	441834.01	5025394.66	79.83	0	D	A	71.8	0.8	0.0	0.0	0.0	56.6	1.3	-3.0	0.0	0.0	24.1	0.0	0.0	-6.5
563	441833.61	5025395.72	79.84	0	D	A	71.8	0.3	0.0	0.0	0.0	56.6	1.3	-3.0	0.0	0.0	24.2	0.0	0.0	-7.0
570	441833.18	5025396.83	79.85	0	D	A	71.8	1.2	0.0	0.0	0.0	56.6	1.3	-3.0	0.0	0.0	24.2	0.0	0.0	-6.2
580	441832.75	5025397.96	79.85	0	D	A	71.8	0.4	0.0	0.0	0.0	56.6	1.3	-3.0	0.0	0.0	24.2	0.0	0.0	-7.0
599	441832.35	5025399.00	79.86	0	D	A	71.8	0.5	0.0	0.0	0.0	56.6	1.3	-3.0	0.0	0.0	24.3	0.0	0.0	-6.9
611	441831.88	5025400.22	79.87	0	D	A	71.8	1.8	0.0	0.0	0.0	56.7	1.3	-3.0	0.0	0.0	24.3	0.0	0.0	-5.7
616	441831.36	5025401.57	79.88	0	D	A	71.8	1.4	0.0	0.0	0.0	56.7	1.3	-3.0	0.0	0.0	24.3	0.0	0.0	-6.1
624	441830.89	5025402.80	79.88	0	D	A	71.8	0.9	0.0	0.0	0.0	56.7	1.3	-3.0	0.0	0.0	24.3	0.0	0.0	-6.6
648	441830.48	5025403.89	79.89	0	D	A	71.8	0.3	0.0	0.0	0.0	56.7	1.3	-3.0	0.0	0.0	24.4	0.0	0.0	-7.3
658	441830.07	5025404.94	79.90	0	D	A	71.8	0.7	0.0	0.0	0.0	56.7	1.3	-3.0	0.0	0.0	24.4	0.0	0.0	-6.9
668	441829.66	5025406.01	79.90	0	D	A	71.8	0.5	0.0	0.0	0.0	56.7	1.3	-3.0	0.0	0.0	24.4	0.0	0.0	-7.2
674	441829.24	5025407.10	79.91	0	D	A	71.8	0.9	0.0	0.0	0.0	56.7	1.3	-3.0	0.0	0.0	24.4	0.0	0.0	-6.8
702	441828.84	5025408.16	79.92	0	D	A	71.8	0.2	0.0	0.0	0.0	56.7	1.3	-3.0	0.0	0.0	24.4	0.0	0.0	-7.5
713	441828.44	5025409.19	79.92	0	D	A	71.8	0.6	0.0	0.0	0.0	56.8	1.3	-3.0	0.0	0.0	24.4	0.0	0.0	-7.1
721	441828.14	5025409.98	79.93	0	D	A	71.8	-2.7	0.0	0.0	0.0	56.8	1.3	-3.0	0.0	0.0	24.4	0.0	0.0	-10.4
741	441839.42	5025380.56	79.75	1	D	A	71.8	3.7	0.0	0.0	0.0	57.8	1.4	-3.0	0.0	0.0	24.3	0.0	2.6	-7.7
744	441838.79	5025382.21	79.76	1	D	A	71.8	0.8	0.0	0.0	0.0	57.8	1.4	-3.0	0.0	0.0	24.3	0.0	2.6	-10.5
751	441838.37	5025383.30	79.77	1	D	A	71.8	0.5	0.0	0.0	0.0	57.8	1.4	-3.0	0.0	0.0	24.3	0.0	2.6	-10.9
758	441837.98	5025384.32	79.77	1	D	A	71.8	0.3	0.0	0.0	0.0	57.8	1.4	-3.0	0.0	0.0	24.3	0.0	2.6	-11.1
773	441837.59	5025385.35	79.78	1	D	A	71.8	0.6	0.0	0.0	0.0	57.8	1.4	-3.0	0.0	0.0	24.3	0.0	2.6	-10.8
782	441837.16	5025386.45	79.79	1	D	A	71.8	0.9	0.0	0.0	0.0	57.8	1.4	-3.0	0.0	0.0	24.3	0.0	2.6	-10.5
793	441836.64	5025387.81	79.79	1	D	A	71.8	2.3	0.0	0.0	0.0	57.8	1.4	-3.0	0.0	0.0	24.3	0.0	2.6	-9.1
848	441839.09	5025381.43	79.76	1	D	A	71.8	0.9	0.0	0.0	0.0	56.5	1.3	-3.0	0.0	0.0	24.8	0.0	4.0	-10.9
2070	441827.35	5025409.97	79.94	0	D	A	71.8	1.7	0.0	0.0	0.0	56.8	1.3	-3.0	0.0	0.0	24.4	0.0	0.0	-6.1
2079	441825.25	5025409.17	79.97	0	D	A	71.8	4.8	0.0	0.0	0.0	56.9	1.3	-3.0	0.0	0.0	24.4	0.0	0.0	-3.0
2088	441823.18	5025408.39	80.00	0	D	A	71.8	1.4	0.0	0.0	0.0	57.0	1.3	-3.0	0.0	0.0	24.3	0.0	0.0	-6.5
2098	441821.40	5025407.71	80.03	0	D	A	71.8	3.8	0.0	0.0	0.0	57.1	1.3	-3.0	0.0	0.0	24.3	0.0	0.0	-4.1
2107	441819.36	5025406.93	80.06	0	D	A	71.8	2.9	0.0	0.0	0.0	57.2	1.4	-3.0	0.0	0.0	24.3	0.0	0.0	-5.1
2115	441817.57	5025406.25	80.08	0	D	A	71.8	2.7	0.0	0.0	0.0	57.2	1.4	-3.0	0.0	0.0	24.2	0.0	0.0	-5.4
2125	441816.18	5025405.73	80.10	0	D	A	71.8	0.4	0.0	0.0	0.0	57.3	1.4	-3.0	0.0	0.0	24.2	0.0	0.0	-7.7
2133	441815.12	5025405.33	80.12	0	D	A	71.8	0.7	0.0	0.0	0.0	57.4	1.4	-3.0	0.0	0.0	24.2	0.0	0.0	-7.5
2142	441813.82	5025404.83	80.14	0	D	A	71.8	2.1	0.0	0.0	0.0	57.4	1.4	-3.0	0.0	0.0	24.1	0.0	0.0	-6.1
2152	441812.16	5025404.20	80.16	0	D	A	71.8	2.9	0.0	0.0	0.0	57.5	1.4	-3.0	0.0	0.0	24.1	0.0	0.0	-5.3
2162	441810.63	5025403.62	80.19	0	D	A	71.8	1.2	0.0	0.0	0.0	57.5	1.4	-3.0	0.0	0.0	24.1	0.0	0.0	-7.0
2172	441809.21	5025403.08	80.21	0	D	A	71.8	2.4	0.0	0.0	0.0	57.6	1.4	-3.0	0.0	0.0	24.0	0.0	0.0	-5.9
2181	441807.46	5025402.41	80.23	0	D	A	71.8	3.0	0.0	0.0	0.0	57.7	1.4	-3.0	0.0	0.0	24.0	0.0	0.0	-5.3
2190	441805.89	5025401.82	80.26	0	D	A	71.8	1.3	0.0	0.0	0.0	57.7	1.4	-3.0	0.0	0.0	24.0	0.0	0.0	-7.1
2200	441804.46	5025401.28	80.28	0	D	A	71.8	2.3	0.0	0.0	0.0	57.8	1.4	-3.0	0.0	0.0	23.9	0.0	0.0	-6.1

Sample CADNA/A Calculation at Receptor

Line Source, ISO 9613, Name: "Truck Movement to Building B", ID: "SS_TRKM_01"																				
Nr.	X	Y	Z	Refl.	DEN	Freq.	Lw	l/a	Optime	K0	Di	Adiv	Aatm	Agr	Afol	Ahous	Abar	Cmet	RL	Lr
	(m)	(m)	(m)			(Hz)	dB(A)	dB	dB	(dB)	(dB)	(dB)	(dB)	(dB)	(dB)	(dB)	(dB)	(dB)	(dB)	(dB)
2209	441802.99	5025400.72	80.30	0	D	A	71.8	1.6	0.0	0.0	0.0	57.9	1.4	-3.0	0.0	0.0	23.8	0.0	0.0	-6.8
2219	441801.04	5025399.98	80.33	0	D	A	71.8	4.3	0.0	0.0	0.0	57.9	1.5	-3.0	0.0	0.0	23.6	0.0	0.0	-3.9
2228	441798.96	5025399.19	80.36	0	D	A	71.8	2.4	0.0	0.0	0.0	58.0	1.5	-3.0	0.0	0.0	24.4	0.0	0.0	-6.7
2254	441806.84	5025402.18	80.24	1	D	A	71.8	1.9	0.0	0.0	0.0	58.7	1.6	-3.1	0.0	0.0	24.4	0.0	2.5	-10.4
2269	441804.13	5025401.15	80.28	1	D	A	71.8	3.4	0.0	0.0	0.0	58.6	1.5	-3.0	0.0	0.0	24.4	0.0	2.5	-8.9
2277	441802.49	5025400.52	80.31	1	D	A	71.8	1.3	0.0	0.0	0.0	58.5	1.5	-3.0	0.0	0.0	24.5	0.0	2.1	-10.6
2295	441800.15	5025399.64	80.34	1	D	A	71.8	1.4	0.0	0.0	0.0	58.4	1.5	-3.0	0.0	0.0	24.5	0.0	2.1	-10.4
2304	441798.91	5025399.17	80.36	1	D	A	71.8	1.0	0.0	0.0	0.0	58.4	1.5	-3.0	0.0	0.0	24.5	0.0	2.0	-10.7
2328	441826.64	5025400.79	79.91	0	D	A	71.8	0.5	0.0	0.0	0.0	56.9	1.3	-3.0	0.0	0.0	24.2	0.0	0.0	-7.2
2338	441827.06	5025399.67	79.91	0	D	A	71.8	1.0	0.0	0.0	0.0	56.9	1.3	-3.0	0.0	0.0	24.2	0.0	0.0	-6.6
2349	441827.51	5025398.48	79.90	0	D	A	71.8	1.0	0.0	0.0	0.0	56.9	1.3	-3.0	0.0	0.0	24.2	0.0	0.0	-6.5
2360	441827.92	5025397.38	79.90	0	D	A	71.8	0.3	0.0	0.0	0.0	56.9	1.3	-3.0	0.0	0.0	24.1	0.0	0.0	-7.2
2369	441828.32	5025396.32	79.90	0	D	A	71.8	0.7	0.0	0.0	0.0	56.8	1.3	-3.0	0.0	0.0	24.1	0.0	0.0	-6.8
2379	441828.70	5025395.29	79.89	0	D	A	71.8	0.0	0.0	0.0	0.0	56.8	1.3	-3.0	0.0	0.0	24.1	0.0	0.0	-7.4
2388	441829.10	5025394.23	79.89	0	D	A	71.8	1.0	0.0	0.0	0.0	56.8	1.3	-3.0	0.0	0.0	24.0	0.0	0.0	-6.4
2398	441829.50	5025393.16	79.88	0	D	A	71.8	0.1	0.0	0.0	0.0	56.8	1.3	-3.0	0.0	0.0	24.0	0.0	0.0	-7.2
2408	441829.91	5025392.06	79.88	0	D	A	71.8	1.1	0.0	0.0	0.0	56.8	1.3	-3.0	0.0	0.0	23.9	0.0	0.0	-6.2
2417	441830.35	5025390.88	79.87	0	D	A	71.8	0.9	0.0	0.0	0.0	56.8	1.3	-3.0	0.0	0.0	23.9	0.0	0.0	-6.4
2428	441830.75	5025389.81	79.87	0	D	A	71.8	0.2	0.0	0.0	0.0	56.8	1.3	-3.0	0.0	0.0	23.9	0.0	0.0	-7.0
2438	441831.11	5025388.84	79.86	0	D	A	71.8	0.1	0.0	0.0	0.0	56.8	1.3	-3.0	0.0	0.0	23.8	0.0	0.0	-7.1
2448	441831.50	5025387.80	79.86	0	D	A	71.8	0.8	0.0	0.0	0.0	56.8	1.3	-3.0	0.0	0.0	23.8	0.0	0.0	-6.3
2456	441831.92	5025386.67	79.85	0	D	A	71.8	0.8	0.0	0.0	0.0	56.8	1.3	-3.0	0.0	0.0	23.7	0.0	0.0	-6.3
2466	441832.43	5025385.30	79.85	0	D	A	71.8	2.4	0.0	0.0	0.0	56.8	1.3	-3.0	0.0	0.0	23.7	0.0	0.0	-4.6
2477	441832.96	5025383.88	79.84	0	D	A	71.8	1.2	0.0	0.0	0.0	56.8	1.3	-3.0	0.0	0.0	23.6	0.0	0.0	-5.7
2487	441833.38	5025382.77	79.84	0	D	A	71.8	0.3	0.0	0.0	0.0	56.8	1.3	-3.0	0.0	0.0	23.4	0.0	0.0	-6.4
2497	441833.74	5025381.80	79.83	0	D	A	71.8	0.0	0.0	0.0	0.0	56.7	1.3	-3.0	0.0	0.0	23.3	0.0	0.0	-6.6
2507	441834.13	5025380.77	79.83	0	D	A	71.8	0.8	0.0	0.0	0.0	56.7	1.3	-3.0	0.0	0.0	23.3	0.0	0.0	-5.8
2516	441834.54	5025379.67	79.82	0	D	A	71.8	0.6	0.0	0.0	0.0	56.7	1.3	-3.0	0.0	0.0	23.1	0.0	0.0	-5.8
2525	441834.92	5025378.63	79.82	0	D	A	71.8	0.3	0.0	0.0	0.0	56.7	1.3	-3.0	0.0	0.0	23.1	0.0	0.0	-6.1
2534	441835.29	5025377.64	79.81	0	D	A	71.8	0.3	0.0	0.0	0.0	56.7	1.3	-3.0	0.0	0.0	23.0	0.0	0.0	-6.0
2543	441835.72	5025376.49	79.81	0	D	A	71.8	1.4	0.0	0.0	0.0	56.7	1.3	-3.0	0.0	0.0	23.0	0.0	0.0	-4.8
2551	441836.16	5025375.32	79.80	0	D	A	71.8	0.5	0.0	0.0	0.0	56.7	1.3	-3.0	0.0	0.0	22.9	0.0	0.0	-5.6
2561	441836.54	5025374.32	79.80	0	D	A	71.8	0.0	0.0	0.0	0.0	56.7	1.3	-3.0	0.0	0.0	22.8	0.0	0.0	-6.1
2572	441836.90	5025373.35	79.80	0	D	A	71.8	0.2	0.0	0.0	0.0	56.7	1.3	-3.0	0.0	0.0	22.8	0.0	0.0	-5.8
2582	441837.18	5025372.60	79.79	0	D	A	71.8	-2.5	0.0	0.0	0.0	56.7	1.3	-3.0	0.0	0.0	22.7	0.0	0.0	-8.4
2596	441832.67	5025384.65	79.84	1	D	A	71.8	0.4	0.0	0.0	0.0	57.6	1.4	-3.0	0.0	0.0	24.4	0.0	2.1	-10.4
2603	441833.09	5025383.55	79.84	1	D	A	71.8	1.0	0.0	0.0	0.0	57.6	1.4	-3.0	0.0	0.0	24.4	0.0	2.1	-9.8
2612	441833.58	5025382.23	79.83	1	D	A	71.8	1.9	0.0	0.0	0.0	57.6	1.4	-3.0	0.0	0.0	24.4	0.0	2.1	-8.8
2621	441834.06	5025380.94	79.83	1	D	A	71.8	0.7	0.0	0.0	0.0	57.6	1.4	-3.0	0.0	0.0	24.4	0.0	2.1	-10.0
2630	441834.48	5025379.83	79.82	1	D	A	71.8	0.7	0.0	0.0	0.0	57.6	1.4	-3.0	0.0	0.0	24.4	0.0	2.1	-10.0
2636	441834.95	5025378.56	79.82	1	D	A	71.8	1.9	0.0	0.0	0.0	57.6	1.4	-3.0	0.0	0.0	24.4	0.0	2.1	-8.9
2644	441835.44	5025377.25	79.81	1	D	A	71.8	1.0	0.0	0.0	0.0	57.6	1.4	-3.0	0.0	0.0	24.4	0.0	2.1	-9.7
2663	441836.22	5025375.17	79.80	1	D	A	71.8	1.2	0.0	0.0	0.0	58.1	1.5	-3.0	0.0	0.0	24.2	0.0	2.6	-10.5
2681	441837.00	5025373.08	79.80	1	D	A	71.8	0.5	0.0	0.0	0.0	58.1	1.5	-3.0	0.0	0.0	23.9	0.0	2.8	-11.0
2783	441801.58	5025391.92	80.22	0	D	A	71.8	1.6	0.0	0.0	0.0	58.0	1.5	-3.0	0.0	0.0	24.4	0.0	0.0	-7.5
2792	441802.97	5025392.44	80.20	0	D	A	71.8	1.8	0.0	0.0	0.0	57.9	1.5	-3.0	0.0	0.0	24.5	0.0	0.0	-7.3
2800	441804.23	5025392.92	80.18	0	D	A	71.8	0.7	0.0	0.0	0.0	57.9	1.4	-3.0	0.0	0.0	24.5	0.0	0.0	-8.3
2810	441806.52	5025393.78	80.16	0	D	A	71.8	5.7	0.0	0.0	0.0	57.8	1.4	-3.0	0.0	0.0	24.5	0.0	0.0	-3.3
2819	441808.81	5025394.65	80.13	0	D	A	71.8	0.7	0.0	0.0	0.0	57.7	1.4	-3.0	0.0	0.0	24.6	0.0	0.0	-8.3
2829	441810.22	5025395.18	80.11	0	D	A	71.8	2.7	0.0	0.0	0.0	57.6	1.4	-3.0	0.0	0.0	24.6	0.0	0.0	-6.2
2838	441811.86	5025395.80	80.09	0	D	A	71.8	2.2	0.0	0.0	0.0	57.5	1.4	-3.0	0.0	0.0	24.6	0.0	0.0	-6.6
2846	441813.32	5025396.36	80.08	0	D	A	71.8	1.8	0.0	0.0	0.0	57.5	1.4	-3.0	0.0	0.0	23.9	0.0	0.0	-6.3
2854	441814.71	5025396.88	80.06	0	D	A	71.8	1.7	0.0	0.0	0.0	57.4	1.4	-3.0	0.0	0.0	24.0	0.0	0.0	-6.3
2863	441816.65	5025397.61	80.04	0	D	A	71.8	4.3	0.0	0.0	0.0	57.3	1.4	-3.0	0.0	0.0	24.0	0.0	0.0	-3.7
2871	441819.55	5025398.71	80.00	0	D	A	71.8	5.5	0.0	0.0	0.0	57.2	1.4	-3.0	0.0	0.0	24.1	0.0	0.0	-2.4
2880	441822.63	5025399.88	79.96	0	D	A	71.8	4.8	0.0	0.0	0.0	57.1	1.3	-3.0	0.0	0.0	24.1	0.0	0.0	-3.0
2889	441824.84	5025400.71	79.94	0	D	A	71.8	2.3	0.0	0.0	0.0	57.0	1.3	-3.0	0.0	0.0	24.2	0.0	0.0	-5.4
2897	441826.04	5025401.17	79.92	0	D	A	71.8	-0.6	0.0	0.0	0.0	56.9	1.3	-3.0	0.0	0.0	24.2	0.0	0.0	-8.3
2905	441801.71	5025391.97	80.22	1	D	A	71.8	2.4	0.0	0.0	0.0	58.3	1.5	-3.0	0.0	0.0	24.5	0.0	2.0	-9.2
2910	441803.36	5025392.59	80.20	1	D	A	71.8	2.5	0.0	0.0	0.0	58.4	1.5	-3.0	0.0	0.0	24.5	0.0	2.1	-9.2
2916	441805.12	5025393.26	80.17	1	D	A	71.8	3.0	0.0	0.0	0.0	58.5	1.5	-3.0	0.0	0.0	24.5	0.0	2.1	-8.9
2923	441806.96	5025393.95	80.15	1	D	A	71.8	2.9	0.0	0.0	0.0	58.5	1.5	-3.0	0.0	0.0	24.5	0.0	2.1	-9.0
2931	441808.53	5025394.54	80.13	1	D	A	71.8	1.5	0.0	0.0	0.0	58.6	1.5	-3.0	0.0	0.0	24.4	0.0	2.5	-10.8

Sample CADNA/A Calculation at Receptor

Line Source, ISO 9613, Name: "Truck Movement to Building B", ID: "SS_TRKM_01"																				
Nr.	X	Y	Z	Refl.	DEN	Freq.	Lw	l/a	Optime	K0	Di	Adiv	Aatm	Agr	Afol	Ahous	Abar	Cmet	RL	Lr
	(m)	(m)	(m)			(Hz)	dB(A)	dB	dB	(dB)	(dB)	(dB)	(dB)	(dB)	(dB)	(dB)	(dB)	(dB)	(dB)	dB(A)
3034	441798.01	5025398.09	80.36	0	D	A	71.8	1.4	0.0	0.0	0.0	58.1	1.5	-3.0	0.0	0.0	24.4	0.0	0.0	-7.8
3043	441798.61	5025396.75	80.34	0	D	A	71.8	2.0	0.0	0.0	0.0	58.1	1.5	-3.0	0.0	0.0	24.4	0.0	0.0	-7.2
3051	441799.24	5025395.36	80.31	0	D	A	71.8	1.7	0.0	0.0	0.0	58.0	1.5	-3.0	0.0	0.0	24.4	0.0	0.0	-7.5
3060	441799.76	5025394.19	80.28	0	D	A	71.8	0.3	0.0	0.0	0.0	58.0	1.5	-3.0	0.0	0.0	24.4	0.0	0.0	-8.8
3068	441800.25	5025393.10	80.26	0	D	A	71.8	1.2	0.0	0.0	0.0	58.0	1.5	-3.0	0.0	0.0	24.4	0.0	0.0	-7.9
3075	441800.71	5025392.08	80.23	0	D	A	71.8	-0.4	0.0	0.0	0.0	58.0	1.5	-3.0	0.0	0.0	24.4	0.0	0.0	-9.5
3092	441798.43	5025397.16	80.34	1	D	A	71.8	1.0	0.0	0.0	0.0	58.3	1.5	-3.0	0.0	0.0	24.5	0.0	2.0	-10.7
3100	441798.92	5025396.06	80.32	1	D	A	71.8	0.7	0.0	0.0	0.0	58.3	1.5	-3.0	0.0	0.0	24.5	0.0	2.0	-11.0
3108	441799.48	5025394.83	80.29	1	D	A	71.8	1.9	0.0	0.0	0.0	58.3	1.5	-3.0	0.0	0.0	24.5	0.0	2.0	-9.8
3123	441800.47	5025392.61	80.25	1	D	A	71.8	0.6	0.0	0.0	0.0	58.3	1.5	-3.0	0.0	0.0	24.5	0.0	2.0	-11.0

Point Source, ISO 9613, Name: "HVAC 10T Unit", ID: "SS_BLDA_HVAC_01"																				
Nr.	X	Y	Z	Refl.	DEN	Freq.	Lw	l/a	Optime	K0	Di	Adiv	Aatm	Agr	Afol	Ahous	Abar	Cmet	RL	Lr
	(m)	(m)	(m)			(Hz)	dB(A)	dB	dB	(dB)	(dB)	(dB)	(dB)	(dB)	(dB)	(dB)	(dB)	(dB)	(dB)	dB(A)
892	441837.92	5025436.51	100.80	0	D	A	79.9	0.0	0.0	0.0	0.0	56.3	0.4	-3.0	0.0	0.0	8.7	0.0	0.0	17.4
892	441837.92	5025436.51	100.80	0	N	A	79.9	0.0	0.0	0.0	0.0	56.3	0.4	-3.0	0.0	0.0	8.7	0.0	0.0	17.4
895	441837.92	5025436.51	100.80	1	D	A	79.9	0.0	0.0	0.0	0.0	57.3	0.4	-3.0	0.0	0.0	9.2	0.0	2.0	14.0
895	441837.92	5025436.51	100.80	1	N	A	79.9	0.0	0.0	0.0	0.0	57.3	0.4	-3.0	0.0	0.0	9.2	0.0	2.0	14.0
907	441837.92	5025436.51	100.80	1	D	A	79.9	0.0	0.0	0.0	0.0	56.7	0.4	-3.0	0.0	0.0	8.6	0.0	2.0	15.3
907	441837.92	5025436.51	100.80	1	N	A	79.9	0.0	0.0	0.0	0.0	56.7	0.4	-3.0	0.0	0.0	8.6	0.0	2.0	15.3

Point Source, ISO 9613, Name: "Truck Idling at Loading Bay - Bldg A", ID: "SS_TRKI_02"																				
Nr.	X	Y	Z	Refl.	DEN	Freq.	Lw	l/a	Optime	K0	Di	Adiv	Aatm	Agr	Afol	Ahous	Abar	Cmet	RL	Lr
	(m)	(m)	(m)			(Hz)	dB(A)	dB	dB	(dB)	(dB)	(dB)	(dB)	(dB)	(dB)	(dB)	(dB)	(dB)	(dB)	dB(A)
913	441822.65	5025426.57	80.29	0	D	A	98.5	0.0	-10.8	0.0	0.0	57.0	1.0	-3.0	0.0	0.0	24.4	0.0	0.0	8.4

Line Source, ISO 9613, Name: "Truck Movement to Building A (North Side)", ID: "SS_TRKM_02"																				
Nr.	X	Y	Z	Refl.	DEN	Freq.	Lw	l/a	Optime	K0	Di	Adiv	Aatm	Agr	Afol	Ahous	Abar	Cmet	RL	Lr
	(m)	(m)	(m)			(Hz)	dB(A)	dB	dB	(dB)	(dB)	(dB)	(dB)	(dB)	(dB)	(dB)	(dB)	(dB)	(dB)	dB(A)
921	441819.30	5025425.80	80.37	0	D	A	69.3	2.0	0.0	0.0	0.0	57.1	1.3	-3.0	0.0	0.0	24.5	0.0	0.0	-8.6
930	441819.95	5025424.19	80.35	0	D	A	69.3	2.7	0.0	0.0	0.0	57.1	1.3	-3.0	0.0	0.0	24.5	0.0	0.0	-7.8
935	441820.49	5025422.83	80.33	0	D	A	69.3	0.2	0.0	0.0	0.0	57.1	1.3	-3.0	0.0	0.0	24.5	0.0	0.0	-10.4
941	441820.88	5025421.86	80.32	0	D	A	69.3	0.3	0.0	0.0	0.0	57.1	1.3	-3.0	0.0	0.0	24.5	0.0	0.0	-10.3
951	441821.27	5025420.88	80.31	0	D	A	69.3	0.2	0.0	0.0	0.0	57.0	1.3	-3.0	0.0	0.0	24.5	0.0	0.0	-10.4
961	441821.93	5025419.23	80.29	0	D	A	69.3	4.0	0.0	0.0	0.0	57.0	1.3	-3.0	0.0	0.0	24.5	0.0	0.0	-6.5
974	441822.60	5025417.56	80.27	0	D	A	69.3	0.3	0.0	0.0	0.0	57.0	1.3	-3.0	0.0	0.0	24.5	0.0	0.0	-10.1
982	441823.05	5025416.43	80.25	0	D	A	69.3	1.3	0.0	0.0	0.0	57.0	1.3	-3.0	0.0	0.0	24.4	0.0	0.0	-9.1
991	441823.52	5025415.28	80.24	0	D	A	69.3	0.5	0.0	0.0	0.0	57.0	1.3	-3.0	0.0	0.0	24.4	0.0	0.0	-9.9
998	441824.07	5025413.90	80.22	0	D	A	69.3	2.6	0.0	0.0	0.0	56.9	1.3	-3.0	0.0	0.0	24.4	0.0	0.0	-7.7
1005	441824.61	5025412.54	80.20	0	D	A	69.3	0.4	0.0	0.0	0.0	56.9	1.3	-3.0	0.0	0.0	24.4	0.0	0.0	-9.9
1017	441825.04	5025411.48	80.19	0	D	A	69.3	0.8	0.0	0.0	0.0	56.9	1.3	-3.0	0.0	0.0	24.4	0.0	0.0	-9.5
1027	441825.52	5025410.27	80.18	0	D	A	69.3	1.5	0.0	0.0	0.0	56.9	1.3	-3.0	0.0	0.0	24.4	0.0	0.0	-8.8
1038	441825.97	5025409.15	80.16	0	D	A	69.3	0.1	0.0	0.0	0.0	56.9	1.3	-3.0	0.0	0.0	24.4	0.0	0.0	-10.2
1045	441826.40	5025408.10	80.15	0	D	A	69.3	0.9	0.0	0.0	0.0	56.9	1.3	-3.0	0.0	0.0	24.4	0.0	0.0	-9.3
1056	441826.82	5025407.04	80.14	0	D	A	69.3	0.1	0.0	0.0	0.0	56.8	1.3	-3.0	0.0	0.0	24.4	0.0	0.0	-10.1
1070	441827.21	5025406.06	80.12	0	D	A	69.3	0.4	0.0	0.0	0.0	56.8	1.3	-3.0	0.0	0.0	24.3	0.0	0.0	-9.8
1081	441827.62	5025405.04	80.11	0	D	A	69.3	0.5	0.0	0.0	0.0	56.8	1.3	-3.0	0.0	0.0	24.3	0.0	0.0	-9.7
1091	441828.12	5025403.80	80.10	0	D	A	69.3	2.0	0.0	0.0	0.0	56.8	1.3	-3.0	0.0	0.0	24.3	0.0	0.0	-8.1
1101	441828.65	5025402.48	80.08	0	D	A	69.3	1.0	0.0	0.0	0.0	56.8	1.3	-3.0	0.0	0.0	24.3	0.0	0.0	-9.0
1108	441829.13	5025401.28	80.07	0	D	A	69.3	1.3	0.0	0.0	0.0	56.8	1.3	-3.0	0.0	0.0	24.3	0.0	0.0	-8.7
1117	441829.61	5025400.07	80.05	0	D	A	69.3	1.0	0.0	0.0	0.0	56.8	1.3	-3.0	0.0	0.0	24.2	0.0	0.0	-9.0
1127	441830.08	5025398.90	80.04	0	D	A	69.3	1.0	0.0	0.0	0.0	56.8	1.3	-3.0	0.0	0.0	24.2	0.0	0.0	-8.9
1137	441830.52	5025397.81	80.02	0	D	A	69.3	0.3	0.0	0.0	0.0	56.7	1.3	-3.0	0.0	0.0	24.2	0.0	0.0	-9.6
1143	441830.94	5025396.77	80.01	0	D	A	69.3	0.7	0.0	0.0	0.0	56.7	1.3	-3.0	0.0	0.0	24.1	0.0	0.0	-9.2
1150	441831.34	5025395.77	80.00	0	D	A	69.3	0.0	0.0	0.0	0.0	56.7	1.3	-3.0	0.0	0.0	24.1	0.0	0.0	-9.8
1157	441831.76	5025394.72	79.99	0	D	A	69.3	1.0	0.0	0.0	0.0	56.7	1.3	-3.0	0.0	0.0	24.1	0.0	0.0	-8.8
1167	441832.18	5025393.67	79.97	0	D	A	69.3	0.1	0.0	0.0	0.0	56.7	1.3	-3.0	0.0	0.0	24.0	0.0	0.0	-9.6
1178	441832.61	5025392.60	79.96	0	D	A	69.3	1.1	0.0	0.0	0.0	56.7	1.3	-3.0	0.0	0.0	24.0	0.0	0.0	-8.6
1193	441833.08	5025391.43	79.95	0	D	A	69.3	0.9	0.0	0.0	0.0	56.7	1.3	-3.0	0.0	0.0	24.0	0.0	0.0	-8.7
1203	441833.50	5025390.39	79.93	0	D	A	69.3	0.2	0.0	0.0	0.0	56.7	1.3	-3.0	0.0	0.0	23.9	0.0	0.0	-9.4
1213	441833.88	5025389.44	79.92	0	D	A	69.3	0.0	0.0	0.0	0.0	56.7	1.3	-3.0	0.0	0.0	23.9	0.0	0.0	-9.4
1222	441834.29	5025388.42	79.91	0	D	A	69.3	0.8	0.0	0.0	0.0	56.7	1.3	-3.0	0.0	0.0	23.8	0.0	0.0	-8.7
1233	441834.73	5025387.31	79.89	0	D	A	69.3	0.7	0.0	0.0	0.0	56.6	1.3	-3.0	0.0	0.0	23.8	0.0	0.0	-8.6
1243	441835.27	5025385.97	79.88	0	D	A	69.3	2.3	0.0	0.0	0.0	56.6	1.3	-3.0	0.0	0.0	23.7	0.0	0.0	-7.0

Sample CADNA/A Calculation at Receptor

Line Source, ISO 9613, Name: "Truck Movement to Building A (North Side)", ID: "SS_TRKM_02"																				
Nr.	X	Y	Z	Refl.	DEN	Freq.	Lw	l/a	Optime	K0	Di	Adiv	Aatm	Agr	Afol	Ahous	Abar	Cmet	RL	Lr
	(m)	(m)	(m)			(Hz)	dB(A)	dB	dB	(dB)	(dB)	(dB)	(dB)	(dB)	(dB)	(dB)	(dB)	(dB)	(dB)	dB(A)
1252	441835.82	5025384.58	79.86	0	D	A	69.3	1.1	0.0	0.0	0.0	56.6	1.3	-3.0	0.0	0.0	23.6	0.0	0.0	-8.1
1260	441836.26	5025383.49	79.85	0	D	A	69.3	0.2	0.0	0.0	0.0	56.6	1.3	-3.0	0.0	0.0	23.4	0.0	0.0	-8.8
1269	441836.68	5025382.44	79.83	0	D	A	69.3	0.8	0.0	0.0	0.0	56.6	1.3	-3.0	0.0	0.0	23.4	0.0	0.0	-8.2
1276	441837.11	5025381.36	79.82	0	D	A	69.3	0.5	0.0	0.0	0.0	56.6	1.3	-3.0	0.0	0.0	23.3	0.0	0.0	-8.3
1286	441837.59	5025380.17	79.81	0	D	A	69.3	1.6	0.0	0.0	0.0	56.6	1.3	-3.0	0.0	0.0	23.3	0.0	0.0	-7.3
1296	441838.06	5025378.99	79.79	0	D	A	69.3	0.5	0.0	0.0	0.0	56.6	1.3	-3.0	0.0	0.0	23.1	0.0	0.0	-8.2
1306	441838.62	5025377.60	79.78	0	D	A	69.3	2.8	0.0	0.0	0.0	56.6	1.3	-3.0	0.0	0.0	23.1	0.0	0.0	-5.8
1315	441839.18	5025376.20	79.76	0	D	A	69.3	0.5	0.0	0.0	0.0	56.6	1.3	-3.0	0.0	0.0	23.0	0.0	0.0	-8.0
1325	441839.56	5025375.27	79.75	0	D	A	69.3	-0.4	0.0	0.0	0.0	56.6	1.3	-3.0	0.0	0.0	22.9	0.0	0.0	-8.9
1497	441838.08	5025374.47	79.77	0	D	A	69.3	1.9	0.0	0.0	0.0	56.6	1.3	-3.0	0.0	0.0	22.8	0.0	0.0	-6.5
1506	441837.61	5025375.73	79.79	0	D	A	69.3	0.6	0.0	0.0	0.0	56.7	1.3	-3.0	0.0	0.0	22.9	0.0	0.0	-8.0
1516	441837.17	5025376.91	79.80	0	D	A	69.3	1.4	0.0	0.0	0.0	56.7	1.3	-3.0	0.0	0.0	23.0	0.0	0.0	-7.3
1525	441836.75	5025378.04	79.82	0	D	A	69.3	0.2	0.0	0.0	0.0	56.7	1.3	-3.0	0.0	0.0	23.1	0.0	0.0	-8.4
1534	441836.38	5025379.03	79.83	0	D	A	69.3	0.2	0.0	0.0	0.0	56.7	1.3	-3.0	0.0	0.0	23.1	0.0	0.0	-8.5
1543	441836.00	5025380.06	79.84	0	D	A	69.3	0.5	0.0	0.0	0.0	56.7	1.3	-3.0	0.0	0.0	23.2	0.0	0.0	-8.3
1552	441835.59	5025381.15	79.85	0	D	A	69.3	0.7	0.0	0.0	0.0	56.7	1.3	-3.0	0.0	0.0	23.3	0.0	0.0	-8.2
1562	441835.18	5025382.25	79.87	0	D	A	69.3	0.7	0.0	0.0	0.0	56.7	1.3	-3.0	0.0	0.0	23.4	0.0	0.0	-8.3
1571	441834.76	5025383.36	79.88	0	D	A	69.3	0.8	0.0	0.0	0.0	56.7	1.3	-3.0	0.0	0.0	23.6	0.0	0.0	-8.4
1581	441834.13	5025385.05	79.90	0	D	A	69.3	3.8	0.0	0.0	0.0	56.7	1.3	-3.0	0.0	0.0	23.7	0.0	0.0	-5.5
1589	441833.53	5025386.66	79.92	0	D	A	69.3	0.2	0.0	0.0	0.0	56.7	1.3	-3.0	0.0	0.0	23.7	0.0	0.0	-9.2
1597	441833.16	5025387.66	79.93	0	D	A	69.3	0.3	0.0	0.0	0.0	56.7	1.3	-3.0	0.0	0.0	23.8	0.0	0.0	-9.2
1608	441832.78	5025388.67	79.94	0	D	A	69.3	0.4	0.0	0.0	0.0	56.7	1.3	-3.0	0.0	0.0	23.8	0.0	0.0	-9.1
1617	441832.40	5025389.70	79.95	0	D	A	69.3	0.4	0.0	0.0	0.0	56.7	1.3	-3.0	0.0	0.0	23.9	0.0	0.0	-9.2
1626	441831.99	5025390.80	79.97	0	D	A	69.3	1.0	0.0	0.0	0.0	56.7	1.3	-3.0	0.0	0.0	23.9	0.0	0.0	-8.6
1635	441831.57	5025391.93	79.98	0	D	A	69.3	0.6	0.0	0.0	0.0	56.7	1.3	-3.0	0.0	0.0	24.0	0.0	0.0	-9.1
1645	441831.18	5025392.97	79.99	0	D	A	69.3	0.4	0.0	0.0	0.0	56.7	1.3	-3.0	0.0	0.0	24.0	0.0	0.0	-9.3
1656	441830.77	5025394.05	80.00	0	D	A	69.3	0.8	0.0	0.0	0.0	56.8	1.3	-3.0	0.0	0.0	24.0	0.0	0.0	-8.9
1667	441830.37	5025395.13	80.02	0	D	A	69.3	0.3	0.0	0.0	0.0	56.8	1.3	-3.0	0.0	0.0	24.1	0.0	0.0	-9.5
1677	441829.95	5025396.26	80.03	0	D	A	69.3	1.3	0.0	0.0	0.0	56.8	1.3	-3.0	0.0	0.0	24.1	0.0	0.0	-8.6
1687	441829.52	5025397.41	80.04	0	D	A	69.3	0.5	0.0	0.0	0.0	56.8	1.3	-3.0	0.0	0.0	24.1	0.0	0.0	-9.4
1697	441829.13	5025398.47	80.06	0	D	A	69.3	0.6	0.0	0.0	0.0	56.8	1.3	-3.0	0.0	0.0	24.2	0.0	0.0	-9.4
1707	441828.66	5025399.72	80.07	0	D	A	69.3	1.8	0.0	0.0	0.0	56.8	1.3	-3.0	0.0	0.0	24.2	0.0	0.0	-8.2
1717	441828.15	5025401.09	80.09	0	D	A	69.3	1.5	0.0	0.0	0.0	56.8	1.3	-3.0	0.0	0.0	24.2	0.0	0.0	-8.6
1726	441827.68	5025402.35	80.10	0	D	A	69.3	1.0	0.0	0.0	0.0	56.8	1.3	-3.0	0.0	0.0	24.3	0.0	0.0	-9.1
1735	441827.27	5025403.45	80.11	0	D	A	69.3	0.4	0.0	0.0	0.0	56.8	1.3	-3.0	0.0	0.0	24.3	0.0	0.0	-9.7
1744	441826.87	5025404.53	80.13	0	D	A	69.3	0.8	0.0	0.0	0.0	56.9	1.3	-3.0	0.0	0.0	24.3	0.0	0.0	-9.4
1752	441826.46	5025405.62	80.14	0	D	A	69.3	0.5	0.0	0.0	0.0	56.9	1.3	-3.0	0.0	0.0	24.3	0.0	0.0	-9.7
1760	441826.05	5025406.73	80.15	0	D	A	69.3	0.9	0.0	0.0	0.0	56.9	1.3	-3.0	0.0	0.0	24.3	0.0	0.0	-9.3
1769	441825.64	5025407.80	80.17	0	D	A	69.3	0.2	0.0	0.0	0.0	56.9	1.3	-3.0	0.0	0.0	24.4	0.0	0.0	-10.0
1778	441825.25	5025408.85	80.18	0	D	A	69.3	0.7	0.0	0.0	0.0	56.9	1.3	-3.0	0.0	0.0	24.4	0.0	0.0	-9.6
1788	441824.85	5025409.93	80.19	0	D	A	69.3	0.5	0.0	0.0	0.0	56.9	1.3	-3.0	0.0	0.0	24.4	0.0	0.0	-9.8
1797	441824.48	5025410.93	80.20	0	D	A	69.3	0.0	0.0	0.0	0.0	56.9	1.3	-3.0	0.0	0.0	24.4	0.0	0.0	-10.3
1806	441824.07	5025412.02	80.22	0	D	A	69.3	1.2	0.0	0.0	0.0	56.9	1.3	-3.0	0.0	0.0	24.4	0.0	0.0	-9.1
1815	441823.53	5025413.46	80.23	0	D	A	69.3	2.5	0.0	0.0	0.0	57.0	1.3	-3.0	0.0	0.0	24.4	0.0	0.0	-7.9
1824	441823.01	5025414.87	80.25	0	D	A	69.3	0.9	0.0	0.0	0.0	57.0	1.3	-3.0	0.0	0.0	24.4	0.0	0.0	-9.5
1833	441822.50	5025416.23	80.26	0	D	A	69.3	2.3	0.0	0.0	0.0	57.0	1.3	-3.0	0.0	0.0	24.4	0.0	0.0	-8.2
1842	441822.02	5025417.52	80.28	0	D	A	69.3	0.3	0.0	0.0	0.0	57.0	1.3	-3.0	0.0	0.0	24.4	0.0	0.0	-10.2
1853	441821.48	5025418.97	80.30	0	D	A	69.3	3.0	0.0	0.0	0.0	57.0	1.3	-3.0	0.0	0.0	24.5	0.0	0.0	-7.5
1862	441820.86	5025420.63	80.32	0	D	A	69.3	1.9	0.0	0.0	0.0	57.1	1.3	-3.0	0.0	0.0	24.5	0.0	0.0	-8.7
1872	441820.41	5025421.84	80.33	0	D	A	69.3	0.2	0.0	0.0	0.0	57.1	1.3	-3.0	0.0	0.0	24.5	0.0	0.0	-10.3
1882	441820.04	5025422.82	80.34	0	D	A	69.3	0.1	0.0	0.0	0.0	57.1	1.3	-3.0	0.0	0.0	24.5	0.0	0.0	-10.4
1893	441819.66	5025423.85	80.35	0	D	A	69.3	0.7	0.0	0.0	0.0	57.1	1.3	-3.0	0.0	0.0	24.5	0.0	0.0	-9.9
1904	441819.14	5025425.23	80.37	0	D	A	69.3	2.5	0.0	0.0	0.0	57.1	1.3	-3.0	0.0	0.0	24.5	0.0	0.0	-8.2
1936	441836.42	5025378.93	79.83	1	D	A	69.3	3.6	0.0	0.0	0.0	57.6	1.4	-3.0	0.0	0.0	24.4	0.0	2.1	-9.6
1988	441833.74	5025386.11	79.91	1	D	A	69.3	2.2	0.0	0.0	0.0	57.7	1.4	-3.0	0.0	0.0	24.4	0.0	2.1	-11.0
3141	441819.59	5025427.10	80.37	0	D	A	69.3	3.3	0.0	0.0	0.0	57.1	1.3	-3.0	0.0	0.0	24.5	0.0	0.0	-7.3
3150	441821.21	5025427.80	80.34	0	D	A	69.3	1.4	0.0	0.0	0.0	57.0	1.3	-3.0	0.0	0.0	24.5	0.0	0.0	-9.2
3157	441822.34	5025428.29	80.33	0	D	A	69.3	0.4	0.0	0.0	0.0	57.0	1.3	-3.0	0.0	0.0	24.5	0.0	0.0	-10.1
3164	441824.56	5025429.25	80.29	0	D	A	69.3	5.7	0.0	0.0	0.0	56.9	1.3	-3.0	0.0	0.0	24.6	0.0	0.0	-4.7
3177	441825.10	5025429.43	80.28	0	D	A	69.3	4.2	0.0	0.0	0.0	56.9	1.3	-3.0	0.0	0.0	24.6	0.0	0.0	-6.2
3185	441823.08	5025428.47	80.31	0	D	A	69.3	2.7	0.0	0.0	0.0	57.0	1.3	-3.0	0.0	0.0	24.5	0.0	0.0	-7.8
3192	441821.67	5025427.81	80.33	0	D	A	69.3	1.0	0.0	0.0	0.0	57.0	1.3	-3.0	0.0	0.0	24.5	0.0	0.0	-9.5
3200	441820.05	5025427.04	80.36	0	D	A	69.3	3.6	0.0	0.0	0.0	57.1	1.3	-3.0	0.0	0.0	24.5	0.0	0.0	-7.0

Sample CADNA/A Calculation at Receptor

Point Source, ISO 9613, Name: "Truck Idling at Loading Bay - Bldg B", ID: "SS_TRKI_03"																				
Nr.	X	Y	Z	Refl.	DEN	Freq.	Lw	l/a	Optime	K0	Di	Adiv	Aatm	Agr	Afol	Ahous	Abar	Cmet	RL	Lr
	(m)	(m)	(m)			(Hz)	dB(A)	dB	dB	(dB)	(dB)	(dB)	(dB)	(dB)	(dB)	(dB)	(dB)	(dB)	(dB)	dB(A)
2756	441801.33	5025399.16	80.32	0	D	A	98.5	0.0	-10.8	0.0	0.0	57.9	1.1	-3.0	0.0	0.0	24.1	0.0	0.0	7.6
2764	441801.33	5025399.16	80.32	1	D	A	98.5	0.0	-10.8	0.0	0.0	58.5	1.2	-3.0	0.0	0.0	24.1	0.0	2.2	4.8

Point Source, ISO 9613, Name: "HVAC 10T Unit", ID: "SS_BLDB_HVAC_03"																				
Nr.	X	Y	Z	Refl.	DEN	Freq.	Lw	l/a	Optime	K0	Di	Adiv	Aatm	Agr	Afol	Ahous	Abar	Cmet	RL	Lr
	(m)	(m)	(m)			(Hz)	dB(A)	dB	dB	(dB)	(dB)	(dB)	(dB)	(dB)	(dB)	(dB)	(dB)	(dB)	(dB)	dB(A)
2774	441817.10	5025375.32	87.29	0	D	A	79.9	0.0	0.0	0.0	0.0	57.5	0.4	-3.0	0.0	0.0	12.8	0.0	0.0	12.2
2774	441817.10	5025375.32	87.29	0	N	A	79.9	0.0	0.0	0.0	0.0	57.5	0.4	-3.0	0.0	0.0	12.8	0.0	0.0	12.2

Point Source, ISO 9613, Name: "HVAC 10T Unit", ID: "SS_BLDB_HVAC_02"																				
Nr.	X	Y	Z	Refl.	DEN	Freq.	Lw	l/a	Optime	K0	Di	Adiv	Aatm	Agr	Afol	Ahous	Abar	Cmet	RL	Lr
	(m)	(m)	(m)			(Hz)	dB(A)	dB	dB	(dB)	(dB)	(dB)	(dB)	(dB)	(dB)	(dB)	(dB)	(dB)	(dB)	dB(A)
2954	441800.25	5025369.82	87.29	0	D	A	79.9	0.0	0.0	0.0	0.0	58.2	0.5	-3.0	0.0	0.0	11.6	0.0	0.0	12.6
2954	441800.25	5025369.82	87.29	0	N	A	79.9	0.0	0.0	0.0	0.0	58.2	0.5	-3.0	0.0	0.0	11.6	0.0	0.0	12.6

Point Source, ISO 9613, Name: "HVAC 10T Unit", ID: "SS_BLDB_HVAC_01"																				
Nr.	X	Y	Z	Refl.	DEN	Freq.	Lw	l/a	Optime	K0	Di	Adiv	Aatm	Agr	Afol	Ahous	Abar	Cmet	RL	Lr
	(m)	(m)	(m)			(Hz)	dB(A)	dB	dB	(dB)	(dB)	(dB)	(dB)	(dB)	(dB)	(dB)	(dB)	(dB)	(dB)	dB(A)
2963	441784.00	5025362.97	87.29	0	D	A	79.9	0.0	0.0	0.0	0.0	58.8	0.5	-3.0	0.0	0.0	10.1	0.0	0.0	13.4
2963	441784.00	5025362.97	87.29	0	N	A	79.9	0.0	0.0	0.0	0.0	58.8	0.5	-3.0	0.0	0.0	10.1	0.0	0.0	13.4

Configuration

Configuration Parameter	Value
General	
Max. Error (dB)	0
Max. Search Radius (#(Unit,LEN))	2000
Min. Dist Src to Rcvr	0
Partition	
Raster Factor	0.5
Max. Length of Section (#(Unit,LEN))	1000
Min. Length of Section (#(Unit,LEN))	1
Min. Length of Section (%)	0
Proj. Line Sources	On
Proj. Area Sources	On
Ref. Time	
Reference Time Day (min)	960
Reference Time Night (min)	480
Daytime Penalty (dB)	0
Recr. Time Penalty (dB)	0
Night-time Penalty (dB)	0
DTM	
Standard Height (m)	0
Model of Terrain	Triangulation
Reflection	
max. Order of Reflection	1
Search Radius Src	100
Search Radius Rcvr	100
Max. Distance Source - Rcvr	1000.00 1000.00
Min. Distance Rcvr - Reflector	1.00 1.00
Min. Distance Source - Reflector	0.1
Industrial (ISO 9613)	
Lateral Diffraction	some Obj
Obst. within Area Src do not shield	On
Screening	Excl. Ground Att. over Barrier
	Dz with limit (20/25)
Barrier Coefficients C1,2,3	3.0 20.0 0.0
Temperature (#(Unit,TEMP))	10
rel. Humidity (%)	70
Ground Absorption G	0
Wind Speed for Dir. (#(Unit,SPEED))	3
Roads (TNM)	
Railways (Schall 03 (1990))	
Strictly acc. to Schall 03 / Schall-Transrapid	
Aircraft (???)	
Strictly acc. to AzB	

Line Sources

Name	ID	Result. PWL		Result. PWL'		Lw / Li			Correction			K0	Moving Pt. Src		
		Day/Eve (dBA)	Night (dBA)	Day/Eve (dBA)	Night (dBA)	Type	Value	norm. dB(A)	Day dB(A)	Evening dB(A)	Night dB(A)		Number		Speed (km/h)
Truck Movement to Building B	SS_TRKM_01	93.1	-18.4	71.8	-39.7	PWL-Pt	HTRK_MOV		0	0	0	0	Day/Eve 14	Night 0	15
Truck Movement to Building A (South Side)	SS_TRKM_03	87.9	-20.5	68.7	-39.7	PWL-Pt	HTRK_MOV		0	0	0	0	7	0	15
Truck Movement to Building A (North Side)	SS_TRKM_02	90.4	-18.6	69.3	-39.7	PWL-Pt	HTRK_MOV		0	0	0	0	8	0	15

Point Sources

Name	ID	Result. PWL			Lw / Li		Correction			Operating Time				K0	Height (m)	Coordinates		
		Day	Evening	Night	Type	Value	norm.	Day	Evening	Night	Day / Eve	Night	(dB)	X		Y	Z	
		(dBA)	(dBA)	(dBA)			dB(A)	dB(A)	dB(A)	dB(A)	(min)	(min)	(dB)	(m)		(m)	(m)	
HVAC 10T Unit	SS_BLDA_HVAC_04	79.9	79.9	79.9	Lw	York_10T		0	0	0	60	60	0	1.8	g	441843	5025421	100.8
HVAC 10T Unit	SS_BLDA_HVAC_02	79.9	79.9	79.9	Lw	York_10T		0	0	0	60	60	0	1.8	g	441852.1	5025442	100.8
HVAC 10T Unit	SS_BLDA_HVAC_05	79.9	79.9	79.9	Lw	York_10T		0	0	0	60	60	0	1.8	g	441859.8	5025427	100.8
HVAC 10T Unit	SS_BLDA_HVAC_03	79.9	79.9	79.9	Lw	York_10T		0	0	0	60	60	0	1.8	g	441867.9	5025449	100.8
HVAC 10T Unit	SS_BLDA_HVAC_01	79.9	79.9	79.9	Lw	York_10T		0	0	0	60	60	0	1.8	g	441837.9	5025437	100.8
HVAC 10T Unit	SS_BLDA_HVAC_07	79.9	79.9	79.9	Lw	York_10T		0	0	0	60	60	0	1.8	g	441847.5	5025407	100.8
HVAC 10T Unit	SS_BLDA_HVAC_11	79.9	79.9	79.9	Lw	York_10T		0	0	0	60	60	0	1.8	g	441873.7	5025390	100.8
HVAC 10T Unit	SS_BLDA_HVAC_06	79.9	79.9	79.9	Lw	York_10T		0	0	0	60	60	0	1.8	g	441875.3	5025433	100.8
HVAC 10T Unit	SS_BLDA_HVAC_08	79.9	79.9	79.9	Lw	York_10T		0	0	0	60	60	0	1.8	g	441864.5	5025408	100.8
HVAC 10T Unit	SS_BLDA_HVAC_09	79.9	79.9	79.9	Lw	York_10T		0	0	0	60	60	0	1.8	g	441884.4	5025413	100.8
HVAC 10T Unit	SS_BLDB_HVAC_03	79.9	79.9	79.9	Lw	York_10T		0	0	0	60	60	0	1.8	g	441817.1	5025375	87.29
HVAC 10T Unit	SS_BLDA_HVAC_12	79.9	79.9	79.9	Lw	York_10T		0	0	0	60	60	0	1.8	g	441892.5	5025396	100.8
HVAC 10T Unit	SS_BLDA_HVAC_10	79.9	79.9	79.9	Lw	York_10T		0	0	0	60	60	0	1.8	g	441877.9	5025402	100.8
HVAC 10T Unit	SS_BLDB_HVAC_02	79.9	79.9	79.9	Lw	York_10T		0	0	0	60	60	0	1.8	g	441800.3	5025370	87.29
HVAC 10T Unit	SS_BLDB_HVAC_01	79.9	79.9	79.9	Lw	York_10T		0	0	0	60	60	0	1.8	g	441784	5025363	87.29
Trailer unloading - Forklift	IM_FKLF_03	99.7	99.7	99.7	Lw	FL_imp		0	0	0	60	0	0	1.8	r	441796.2	5025397	79.79
Trailer unloading - Forklift at Building A	IM_FKLF_02	99.7	99.7	99.7	Lw	FL_imp		0	0	0	60	0	0	1.8	r	441898.6	5025390	79.18
Trailer unloading - Forklift - Building A	IM_FKLF_01	99.7	99.7	99.7	Lw	FL_imp		0	0	0	60	0	0	1.8	r	441826.7	5025429	79.63
Truck Idling at Loading Bay - Bldg B	SS_TRKI_03	98.5	98.5	98.5	Lw	HTRK_IDLE		0	0	0	5	0	0	2.4	r	441801.3	5025399	80.32
Truck Idling at Loading Bay - Bldg A	SS_TRKI_02	98.5	98.5	98.5	Lw	HTRK_IDLE		0	0	0	5	0	0	2.4	r	441822.7	5025427	80.29
Truck Idling at Loading Bay - Bldg A	SS_TRKI_01	98.5	98.5	98.5	Lw	HTRK_IDLE		0	0	0	5	0	0	2.4	r	441900	5025386	79.86

Receptor Locations

Name	ID	Level Lr		Limit. Value		Height (m)	Coordinates		
		Day/Eve	Night	Day/Eve	Night		X	Y	Z
		(dBA)	(dBA)	(dBA)	(dBA)		(m)	(m)	(m)
R01_PW	R01_PW	36.1	31.6	50	45	5.5	442021.47	5025430	82.3
R02_PW	R02_PW	37	32.7	50	45	5.5	442032.89	5025402	82.57
R03_PW	R03_PW	39.3	33.1	50	45	5.5	442044.57	5025373	83.44
R04_PW	R04_PW	40.5	32.6	50	45	5.5	442055.72	5025346	84.42
R05_PW	R05_PW	39.5	31.3	50	45	4.5	442056.59	5025292	84.6
R06_PW	R06_PW	39.4	31.4	50	45	4.5	441995.84	5025252	84.93
R07_PW	R07_PW	35.6	31.8	50	45	4.5	441965.54	5025236	85.36
R08_PW	R08_PW	40.3	32.2	50	45	4.5	441912.73	5025204	85.5
R09_PW	R09_PW	29.7	28.9	50	45	4.5	441844.9	5025162	85.5

Sample CADNA/A Calculation at Receptor

Receiver
 Name: R01_PW
 ID: R01_PW
 X: 442021.47 m
 Y: 5025429.82 m
 Z: 82.30 m

Point Source, ISO 9613, Name: "Truck Idling at Loading Bay - Bldg A", ID: "SS_TRKI_01"																				
Nr.	X	Y	Z	Refl.	DEN	Freq.	Lw	l/a	Optime	K0	Di	Adiv	Aatm	Agr	Afol	Ahous	Abar	Cmet	RL	Lr
	(m)	(m)	(m)			(Hz)	dB(A)	dB	dB	(dB)	(dB)	(dB)	(dB)	(dB)	(dB)	(dB)	(dB)	(dB)	(dB)	dB(A)
1	441899.98	5025386.19	79.86	0	D	A	98.5	0.0	-10.8	0.0	0.0	53.2	0.7	-3.0	0.0	0.0	5.5	0.0	0.0	31.3

Point Source, ISO 9613, Name: "HVAC 10T Unit", ID: "SS_BLDA_HVAC_12"																				
Nr.	X	Y	Z	Refl.	DEN	Freq.	Lw	l/a	Optime	K0	Di	Adiv	Aatm	Agr	Afol	Ahous	Abar	Cmet	RL	Lr
	(m)	(m)	(m)			(Hz)	dB(A)	dB	dB	(dB)	(dB)	(dB)	(dB)	(dB)	(dB)	(dB)	(dB)	(dB)	(dB)	dB(A)
2	441892.47	5025396.01	100.80	0	D	A	79.9	0.0	0.0	0.0	0.0	53.6	0.3	-3.0	0.0	0.0	8.3	0.0	0.0	20.7
2	441892.47	5025396.01	100.80	0	N	A	79.9	0.0	0.0	0.0	0.0	53.6	0.3	-3.0	0.0	0.0	8.3	0.0	0.0	20.7
3	441892.47	5025396.01	100.80	1	D	A	79.9	0.0	0.0	0.0	0.0	56.3	0.4	-3.0	0.0	0.0	9.5	0.0	2.0	14.7
3	441892.47	5025396.01	100.80	1	N	A	79.9	0.0	0.0	0.0	0.0	56.3	0.4	-3.0	0.0	0.0	9.5	0.0	2.0	14.7

Point Source, ISO 9613, Name: "HVAC 10T Unit", ID: "SS_BLDA_HVAC_09"																				
Nr.	X	Y	Z	Refl.	DEN	Freq.	Lw	l/a	Optime	K0	Di	Adiv	Aatm	Agr	Afol	Ahous	Abar	Cmet	RL	Lr
	(m)	(m)	(m)			(Hz)	dB(A)	dB	dB	(dB)	(dB)	(dB)	(dB)	(dB)	(dB)	(dB)	(dB)	(dB)	(dB)	dB(A)
4	441884.39	5025413.28	100.80	0	D	A	79.9	0.0	0.0	0.0	0.0	53.9	0.3	-3.0	0.0	0.0	8.3	0.0	0.0	20.5
4	441884.39	5025413.28	100.80	0	N	A	79.9	0.0	0.0	0.0	0.0	53.9	0.3	-3.0	0.0	0.0	8.3	0.0	0.0	20.5
6	441884.39	5025413.28	100.80	1	D	A	79.9	0.0	0.0	0.0	0.0	58.2	0.5	-3.0	0.0	0.0	13.2	0.0	2.0	9.0
6	441884.39	5025413.28	100.80	1	N	A	79.9	0.0	0.0	0.0	0.0	58.2	0.5	-3.0	0.0	0.0	13.2	0.0	2.0	9.0

Point Source, ISO 9613, Name: "HVAC 10T Unit", ID: "SS_BLDA_HVAC_06"																				
Nr.	X	Y	Z	Refl.	DEN	Freq.	Lw	l/a	Optime	K0	Di	Adiv	Aatm	Agr	Afol	Ahous	Abar	Cmet	RL	Lr
	(m)	(m)	(m)			(Hz)	dB(A)	dB	dB	(dB)	(dB)	(dB)	(dB)	(dB)	(dB)	(dB)	(dB)	(dB)	(dB)	dB(A)
8	441875.30	5025432.72	100.80	0	D	A	79.9	0.0	0.0	0.0	0.0	54.4	0.3	-3.0	0.0	0.0	8.1	0.0	0.0	20.1
8	441875.30	5025432.72	100.80	0	N	A	79.9	0.0	0.0	0.0	0.0	54.4	0.3	-3.0	0.0	0.0	8.1	0.0	0.0	20.1
13	441875.30	5025432.72	100.80	1	D	A	79.9	0.0	0.0	0.0	0.0	58.3	0.5	-3.0	0.0	0.0	9.6	0.0	2.0	12.5
13	441875.30	5025432.72	100.80	1	N	A	79.9	0.0	0.0	0.0	0.0	58.3	0.5	-3.0	0.0	0.0	9.6	0.0	2.0	12.5

Point Source, ISO 9613, Name: "HVAC 10T Unit", ID: "SS_BLDA_HVAC_10"																				
Nr.	X	Y	Z	Refl.	DEN	Freq.	Lw	l/a	Optime	K0	Di	Adiv	Aatm	Agr	Afol	Ahous	Abar	Cmet	RL	Lr
	(m)	(m)	(m)			(Hz)	dB(A)	dB	dB	(dB)	(dB)	(dB)	(dB)	(dB)	(dB)	(dB)	(dB)	(dB)	(dB)	dB(A)
20	441877.90	5025401.89	100.80	0	D	A	79.9	0.0	0.0	0.0	0.0	54.4	0.3	-3.0	0.0	0.0	8.4	0.0	0.0	19.8
20	441877.90	5025401.89	100.80	0	N	A	79.9	0.0	0.0	0.0	0.0	54.4	0.3	-3.0	0.0	0.0	8.4	0.0	0.0	19.8
26	441877.90	5025401.89	100.80	1	D	A	79.9	0.0	0.0	0.0	0.0	55.9	0.4	-3.0	0.0	0.0	9.2	0.0	2.0	15.4
26	441877.90	5025401.89	100.80	1	N	A	79.9	0.0	0.0	0.0	0.0	55.9	0.4	-3.0	0.0	0.0	9.2	0.0	2.0	15.4

Point Source, ISO 9613, Name: "HVAC 10T Unit", ID: "SS_BLDA_HVAC_11"																				
Nr.	X	Y	Z	Refl.	DEN	Freq.	Lw	l/a	Optime	K0	Di	Adiv	Aatm	Agr	Afol	Ahous	Abar	Cmet	RL	Lr
	(m)	(m)	(m)			(Hz)	dB(A)	dB	dB	(dB)	(dB)	(dB)	(dB)	(dB)	(dB)	(dB)	(dB)	(dB)	(dB)	dB(A)
30	441873.70	5025389.67	100.80	0	D	A	79.9	0.0	0.0	0.0	0.0	54.8	0.3	-3.0	0.0	0.0	8.8	0.0	0.0	19.0
30	441873.70	5025389.67	100.80	0	N	A	79.9	0.0	0.0	0.0	0.0	54.8	0.3	-3.0	0.0	0.0	8.8	0.0	0.0	19.0
33	441873.70	5025389.67	100.80	1	D	A	79.9	0.0	0.0	0.0	0.0	55.4	0.4	-3.0	0.0	0.0	9.1	0.0	2.0	16.1
33	441873.70	5025389.67	100.80	1	N	A	79.9	0.0	0.0	0.0	0.0	55.4	0.4	-3.0	0.0	0.0	9.1	0.0	2.0	16.1

Point Source, ISO 9613, Name: "HVAC 10T Unit", ID: "SS_BLDA_HVAC_03"																				
Nr.	X	Y	Z	Refl.	DEN	Freq.	Lw	l/a	Optime	K0	Di	Adiv	Aatm	Agr	Afol	Ahous	Abar	Cmet	RL	Lr
	(m)	(m)	(m)			(Hz)	dB(A)	dB	dB	(dB)	(dB)	(dB)	(dB)	(dB)	(dB)	(dB)	(dB)	(dB)	(dB)	dB(A)
49	441867.85	5025448.56	100.80	0	D	A	79.9	0.0	0.0	0.0	0.0	54.9	0.3	-3.0	0.0	0.0	7.8	0.0	0.0	19.9
49	441867.85	5025448.56	100.80	0	N	A	79.9	0.0	0.0	0.0	0.0	54.9	0.3	-3.0	0.0	0.0	7.8	0.0	0.0	19.9
69	441867.85	5025448.56	100.80	1	D	A	79.9	0.0	0.0	0.0	0.0	58.5	0.5	-3.0	0.0	0.0	9.4	0.0	2.0	12.5
69	441867.85	5025448.56	100.80	1	N	A	79.9	0.0	0.0	0.0	0.0	58.5	0.5	-3.0	0.0	0.0	9.4	0.0	2.0	12.5

Point Source, ISO 9613, Name: "HVAC 10T Unit", ID: "SS_BLDA_HVAC_08"																				
Nr.	X	Y	Z	Refl.	DEN	Freq.	Lw	l/a	Optime	K0	Di	Adiv	Aatm	Agr	Afol	Ahous	Abar	Cmet	RL	Lr
	(m)	(m)	(m)			(Hz)	dB(A)	dB	dB	(dB)	(dB)	(dB)	(dB)	(dB)	(dB)	(dB)	(dB)	(dB)	(dB)	dB(A)
79	441864.45	5025407.53	100.80	0	D	A	79.9	0.0	0.0	0.0	0.0	55.1	0.3	-3.0	0.0	0.0	8.7	0.0	0.0	18.8

Point Source, ISO 9613, Name: "HVAC 10T Unit", ID: "SS_BLDA_HVAC_08"																				
Nr.	X	Y	Z	Refl.	DEN	Freq.	Lw	l/a	Optime	K0	Di	Adiv	Aatm	Agr	Afol	Ahous	Abar	Cmet	RL	Lr
	(m)	(m)	(m)			(Hz)	dB(A)	dB	dB	(dB)	(dB)	(dB)	(dB)	(dB)	(dB)	(dB)	(dB)	(dB)	(dB)	dB(A)
79	441864.45	5025407.53	100.80	0	N	A	79.9	0.0	0.0	0.0	0.0	55.1	0.3	-3.0	0.0	0.0	8.7	0.0	0.0	18.8
87	441864.45	5025407.53	100.80	1	D	A	79.9	0.0	0.0	0.0	0.0	57.4	0.4	-3.0	0.0	0.0	9.6	0.0	2.0	13.4
87	441864.45	5025407.53	100.80	1	N	A	79.9	0.0	0.0	0.0	0.0	57.4	0.4	-3.0	0.0	0.0	9.6	0.0	2.0	13.4

Point Source, ISO 9613, Name: "HVAC 10T Unit", ID: "SS_BLDA_HVAC_05"																				
Nr.	X	Y	Z	Refl.	DEN	Freq.	Lw	l/a	Optime	K0	Di	Adiv	Aatm	Agr	Afol	Ahous	Abar	Cmet	RL	Lr
	(m)	(m)	(m)			(Hz)	dB(A)	dB	dB	(dB)	(dB)	(dB)	(dB)	(dB)	(dB)	(dB)	(dB)	(dB)	(dB)	dB(A)
95	441859.79	5025426.88	100.80	0	D	A	79.9	0.0	0.0	0.0	0.0	55.2	0.3	-3.0	0.0	0.0	8.5	0.0	0.0	18.8
95	441859.79	5025426.88	100.80	0	N	A	79.9	0.0	0.0	0.0	0.0	55.2	0.3	-3.0	0.0	0.0	8.5	0.0	0.0	18.8
103	441859.79	5025426.88	100.80	1	D	A	79.9	0.0	0.0	0.0	0.0	57.7	0.5	-3.0	0.0	0.0	9.5	0.0	2.0	13.2
103	441859.79	5025426.88	100.80	1	N	A	79.9	0.0	0.0	0.0	0.0	57.7	0.5	-3.0	0.0	0.0	9.5	0.0	2.0	13.2

Point Source, ISO 9613, Name: "HVAC 10T Unit", ID: "SS_BLDA_HVAC_02"																				
Nr.	X	Y	Z	Refl.	DEN	Freq.	Lw	l/a	Optime	K0	Di	Adiv	Aatm	Agr	Afol	Ahous	Abar	Cmet	RL	Lr
	(m)	(m)	(m)			(Hz)	dB(A)	dB	dB	(dB)	(dB)	(dB)	(dB)	(dB)	(dB)	(dB)	(dB)	(dB)	(dB)	dB(A)
106	441852.11	5025442.31	100.80	0	D	A	79.9	0.0	0.0	0.0	0.0	55.7	0.4	-3.0	0.0	0.0	8.3	0.0	0.0	18.6
106	441852.11	5025442.31	100.80	0	N	A	79.9	0.0	0.0	0.0	0.0	55.7	0.4	-3.0	0.0	0.0	8.3	0.0	0.0	18.6
127	441852.11	5025442.31	100.80	1	D	A	79.9	0.0	0.0	0.0	0.0	57.9	0.5	-3.0	0.0	0.0	9.3	0.0	2.0	13.2
127	441852.11	5025442.31	100.80	1	N	A	79.9	0.0	0.0	0.0	0.0	57.9	0.5	-3.0	0.0	0.0	9.3	0.0	2.0	13.2
135	441852.11	5025442.31	100.80	1	D	A	79.9	0.0	0.0	0.0	0.0	56.0	0.4	-3.0	0.0	0.0	8.2	0.0	2.0	16.3
135	441852.11	5025442.31	100.80	1	N	A	79.9	0.0	0.0	0.0	0.0	56.0	0.4	-3.0	0.0	0.0	8.2	0.0	2.0	16.3

Line Source, ISO 9613, Name: "Truck Movement to Building A (South Side)", ID: "SS_TRKM_03"																				
Nr.	X	Y	Z	Refl.	DEN	Freq.	Lw	l/a	Optime	K0	Di	Adiv	Aatm	Agr	Afol	Ahous	Abar	Cmet	RL	Lr
	(m)	(m)	(m)			(Hz)	dB(A)	dB	dB	(dB)	(dB)	(dB)	(dB)	(dB)	(dB)	(dB)	(dB)	(dB)	(dB)	dB(A)
142	441865.03	5025374.61	79.81	0	D	A	68.7	0.7	0.0	0.0	0.0	55.4	1.1	-3.0	0.0	0.0	4.8	0.0	0.0	11.1
144	441869.55	5025376.50	79.81	0	D	A	68.7	9.4	0.0	0.0	0.0	55.1	1.1	-3.0	0.0	0.0	4.8	0.0	0.0	20.1
146	441874.44	5025378.55	79.81	0	D	A	68.7	2.9	0.0	0.0	0.0	54.8	1.1	-3.0	0.0	0.0	4.8	0.0	0.0	13.9
157	441876.59	5025379.45	79.81	0	D	A	68.7	4.3	0.0	0.0	0.0	54.7	1.1	-3.0	0.0	0.0	4.8	0.0	0.0	15.5
164	441879.74	5025380.77	79.81	0	D	A	68.7	6.2	0.0	0.0	0.0	54.5	1.1	-3.0	0.0	0.0	4.8	0.0	0.0	17.5
177	441883.98	5025382.55	79.81	0	D	A	68.7	7.1	0.0	0.0	0.0	54.3	1.0	-3.0	0.0	0.0	4.9	0.0	0.0	18.6
180	441888.36	5025384.38	79.81	0	D	A	68.7	6.5	0.0	0.0	0.0	54.0	1.0	-3.0	0.0	0.0	5.0	0.0	0.0	18.2
188	441892.00	5025385.90	79.80	0	D	A	68.7	5.4	0.0	0.0	0.0	53.7	1.0	-3.0	0.0	0.0	5.2	0.0	0.0	17.2
191	441894.64	5025387.01	79.80	0	D	A	68.7	3.6	0.0	0.0	0.0	53.5	1.0	-3.0	0.0	0.0	5.4	0.0	0.0	15.4
192	441896.84	5025387.93	79.80	0	D	A	68.7	4.0	0.0	0.0	0.0	53.4	0.9	-3.0	0.0	0.0	5.6	0.0	0.0	15.8
206	441898.96	5025388.82	79.80	0	D	A	68.7	3.3	0.0	0.0	0.0	53.2	0.9	-3.0	0.0	0.0	5.8	0.0	0.0	15.1
215	441865.84	5025374.95	79.81	1	D	A	68.7	4.6	0.0	0.0	0.0	55.4	1.1	-3.0	0.0	0.0	4.8	0.0	17.3	-2.2
233	441867.87	5025375.80	79.81	1	D	A	68.7	1.8	0.0	0.0	0.0	55.3	1.1	-3.0	0.0	0.0	4.8	0.0	17.3	-4.9
239	441869.21	5025376.36	79.81	1	D	A	68.7	1.5	0.0	0.0	0.0	55.2	1.1	-3.0	0.0	0.0	4.8	0.0	17.2	-5.1
242	441871.24	5025377.21	79.81	1	D	A	68.7	4.7	0.0	0.0	0.0	55.1	1.1	-3.0	0.0	0.0	4.8	0.0	17.2	-1.7
245	441873.10	5025377.99	79.81	1	D	A	68.7	0.3	0.0	0.0	0.0	54.9	1.1	-3.0	0.0	0.0	4.8	0.0	17.1	-6.0
247	441874.14	5025378.42	79.81	1	D	A	68.7	0.8	0.0	0.0	0.0	54.9	1.1	-3.0	0.0	0.0	4.8	0.0	17.1	-5.4
260	441875.48	5025378.99	79.81	1	D	A	68.7	2.4	0.0	0.0	0.0	54.8	1.1	-3.0	0.0	0.0	4.8	0.0	17.1	-3.7
279	441876.48	5025379.40	79.81	1	D	A	68.7	-3.6	0.0	0.0	0.0	54.7	1.1	-3.0	0.0	0.0	4.8	0.0	17.1	-9.5
365	441893.57	5025377.59	79.97	0	D	A	68.7	13.2	0.0	0.0	0.0	53.8	1.0	-3.0	0.0	0.0	5.0	0.0	0.0	25.2
370	441876.93	5025370.50	79.96	0	D	A	68.7	11.8	0.0	0.0	0.0	54.9	1.1	-3.0	0.0	0.0	4.8	0.0	0.0	22.8
2972	441900.19	5025388.66	79.82	0	D	A	68.7	0.9	0.0	0.0	0.0	53.2	0.9	-3.0	0.0	0.0	5.9	0.0	0.0	12.7
2980	441900.67	5025387.59	79.84	0	D	A	68.7	0.5	0.0	0.0	0.0	53.1	0.9	-3.0	0.0	0.0	5.8	0.0	0.0	12.3
2988	441901.11	5025386.60	79.86	0	D	A	68.7	0.2	0.0	0.0	0.0	53.1	0.9	-3.0	0.0	0.0	5.8	0.0	0.0	12.1
2996	441901.57	5025385.57	79.89	0	D	A	68.7	0.8	0.0	0.0	0.0	53.1	0.9	-3.0	0.0	0.0	5.7	0.0	0.0	12.7
3003	441902.02	5025384.55	79.91	0	D	A	68.7	0.1	0.0	0.0	0.0	53.1	0.9	-3.0	0.0	0.0	5.7	0.0	0.0	12.1
3011	441902.44	5025383.61	79.94	0	D	A	68.7	0.1	0.0	0.0	0.0	53.1	0.9	-3.0	0.0	0.0	5.7	0.0	0.0	12.2
3018	441902.87	5025382.64	79.96	0	D	A	68.7	0.3	0.0	0.0	0.0	53.1	0.9	-3.0	0.0	0.0	5.6	0.0	0.0	12.4
3026	441903.18	5025381.94	79.98	0	D	A	68.7	-3.3	0.0	0.0	0.0	53.1	0.9	-3.0	0.0	0.0	5.6	0.0	0.0	8.8

Point Source, ISO 9613, Name: "HVAC 10T Unit", ID: "SS_BLDA_HVAC_07"																				
Nr.	X	Y	Z	Refl.	DEN	Freq.	Lw	l/a	Optime	K0	Di	Adiv	Aatm	Agr	Afol	Ahous	Abar	Cmet	RL	Lr
	(m)	(m)	(m)			(Hz)	dB(A)	dB	dB	(dB)	(dB)	(dB)	(dB)	(dB)	(dB)	(dB)	(dB)	(dB)	(dB)	dB(A)
342	441847.54	5025406.88	100.80	0	D	A	79.9	0.0	0.0	0.0	0.0	55.9	0.4	-3.0	0.0	0.0	9.1	0.0	0.0	17.5
342	441847.54	5025406.88	100.80	0	N	A	79.9	0.0	0.0	0.0	0.0	55.9	0.4	-3.0	0.0	0.0	9.1	0.0	0.0	17.5
345	441847.54	5025406.88	100.80	1	D	A	79.9	0.0	0.0	0.0	0.0	56.8	0.4	-3.0	0.0	0.0	9.4	0.0	2.0	14.3
345	441847.54	5025406.88	100.80	1	N	A	79.9	0.0	0.0	0.0	0.0	56.8	0.4	-3.0	0.0	0.0	9.4	0.0	2.0	14.3

Sample CADNA/A Calculation at Receptor

Point Source, ISO 9613, Name: "HVAC 10T Unit", ID: "SS_BLDA_HVAC_04"																				
Nr.	X	Y	Z	Refl.	DEN	Freq.	Lw	l/a	Optime	K0	Di	Adiv	Aatm	Agr	Afol	Ahous	Abar	Cmet	RL	Lr
	(m)	(m)	(m)			(Hz)	dB(A)	dB	dB	(dB)	(dB)	(dB)	(dB)	(dB)	(dB)	(dB)	(dB)	(dB)	(dB)	dB(A)
377	441842.99	5025420.89	100.80	0	D	A	79.9	0.0	0.0	0.0	0.0	56.1	0.4	-3.0	0.0	0.0	8.9	0.0	0.0	17.5
377	441842.99	5025420.89	100.80	0	N	A	79.9	0.0	0.0	0.0	0.0	56.1	0.4	-3.0	0.0	0.0	8.9	0.0	0.0	17.5
380	441842.99	5025420.89	100.80	1	D	A	79.9	0.0	0.0	0.0	0.0	57.0	0.4	-3.0	0.0	0.0	9.3	0.0	2.0	14.1
380	441842.99	5025420.89	100.80	1	N	A	79.9	0.0	0.0	0.0	0.0	57.0	0.4	-3.0	0.0	0.0	9.3	0.0	2.0	14.1
387	441842.99	5025420.89	100.80	1	D	A	79.9	0.0	0.0	0.0	0.0	57.1	0.4	-3.0	0.0	0.0	8.4	0.0	2.0	15.0
387	441842.99	5025420.89	100.80	1	N	A	79.9	0.0	0.0	0.0	0.0	57.1	0.4	-3.0	0.0	0.0	8.4	0.0	2.0	15.0

Line Source, ISO 9613, Name: "Truck Movement to Building B", ID: "SS_TRKM_01"																				
Nr.	X	Y	Z	Refl.	DEN	Freq.	Lw	l/a	Optime	K0	Di	Adiv	Aatm	Agr	Afol	Ahous	Abar	Cmet	RL	Lr
	(m)	(m)	(m)			(Hz)	dB(A)	dB	dB	(dB)	(dB)	(dB)	(dB)	(dB)	(dB)	(dB)	(dB)	(dB)	(dB)	dB(A)
398	441841.13	5025376.10	79.72	0	D	A	71.8	0.5	0.0	0.0	0.0	56.5	1.3	-3.0	0.0	0.0	23.0	0.0	0.0	-5.5
405	441840.57	5025377.55	79.73	0	D	A	71.8	3.0	0.0	0.0	0.0	56.5	1.3	-3.0	0.0	0.0	23.1	0.0	0.0	-3.1
416	441840.03	5025378.97	79.74	0	D	A	71.8	0.2	0.0	0.0	0.0	56.5	1.3	-3.0	0.0	0.0	23.2	0.0	0.0	-6.0
432	441839.66	5025379.94	79.75	0	D	A	71.8	0.2	0.0	0.0	0.0	56.5	1.3	-3.0	0.0	0.0	23.2	0.0	0.0	-6.1
455	441839.28	5025380.94	79.75	0	D	A	71.8	0.5	0.0	0.0	0.0	56.5	1.3	-3.0	0.0	0.0	23.3	0.0	0.0	-5.9
466	441838.87	5025382.01	79.76	0	D	A	71.8	0.7	0.0	0.0	0.0	56.5	1.3	-3.0	0.0	0.0	23.4	0.0	0.0	-5.7
476	441838.45	5025383.09	79.77	0	D	A	71.8	0.6	0.0	0.0	0.0	56.5	1.3	-3.0	0.0	0.0	23.4	0.0	0.0	-5.9
482	441838.03	5025384.18	79.77	0	D	A	71.8	0.8	0.0	0.0	0.0	56.5	1.3	-3.0	0.0	0.0	23.6	0.0	0.0	-5.9
488	441837.40	5025385.83	79.78	0	D	A	71.8	3.7	0.0	0.0	0.0	56.5	1.3	-3.0	0.0	0.0	23.7	0.0	0.0	-3.1
494	441836.79	5025387.41	79.79	0	D	A	71.8	0.2	0.0	0.0	0.0	56.6	1.3	-3.0	0.0	0.0	23.8	0.0	0.0	-6.7
500	441836.42	5025388.39	79.80	0	D	A	71.8	0.2	0.0	0.0	0.0	56.6	1.3	-3.0	0.0	0.0	23.8	0.0	0.0	-6.7
512	441836.04	5025389.38	79.80	0	D	A	71.8	0.3	0.0	0.0	0.0	56.6	1.3	-3.0	0.0	0.0	23.9	0.0	0.0	-6.6
518	441835.65	5025390.39	79.81	0	D	A	71.8	0.3	0.0	0.0	0.0	56.6	1.3	-3.0	0.0	0.0	23.9	0.0	0.0	-6.7
527	441835.24	5025391.47	79.82	0	D	A	71.8	1.0	0.0	0.0	0.0	56.6	1.3	-3.0	0.0	0.0	24.0	0.0	0.0	-6.1
534	441834.81	5025392.58	79.82	0	D	A	71.8	0.5	0.0	0.0	0.0	56.6	1.3	-3.0	0.0	0.0	24.0	0.0	0.0	-6.7
545	441834.42	5025393.60	79.83	0	D	A	71.8	0.3	0.0	0.0	0.0	56.6	1.3	-3.0	0.0	0.0	24.1	0.0	0.0	-6.9
557	441834.01	5025394.66	79.83	0	D	A	71.8	0.8	0.0	0.0	0.0	56.6	1.3	-3.0	0.0	0.0	24.1	0.0	0.0	-6.5
563	441833.61	5025395.72	79.84	0	D	A	71.8	0.3	0.0	0.0	0.0	56.6	1.3	-3.0	0.0	0.0	24.2	0.0	0.0	-7.0
570	441833.18	5025396.83	79.85	0	D	A	71.8	1.2	0.0	0.0	0.0	56.6	1.3	-3.0	0.0	0.0	24.2	0.0	0.0	-6.2
580	441832.75	5025397.96	79.85	0	D	A	71.8	0.4	0.0	0.0	0.0	56.6	1.3	-3.0	0.0	0.0	24.2	0.0	0.0	-7.0
599	441832.35	5025399.00	79.86	0	D	A	71.8	0.5	0.0	0.0	0.0	56.6	1.3	-3.0	0.0	0.0	24.3	0.0	0.0	-6.9
611	441831.88	5025400.22	79.87	0	D	A	71.8	1.8	0.0	0.0	0.0	56.7	1.3	-3.0	0.0	0.0	24.3	0.0	0.0	-5.7
616	441831.36	5025401.57	79.88	0	D	A	71.8	1.4	0.0	0.0	0.0	56.7	1.3	-3.0	0.0	0.0	24.3	0.0	0.0	-6.1
624	441830.89	5025402.80	79.88	0	D	A	71.8	0.9	0.0	0.0	0.0	56.7	1.3	-3.0	0.0	0.0	24.3	0.0	0.0	-6.6
648	441830.48	5025403.89	79.89	0	D	A	71.8	0.3	0.0	0.0	0.0	56.7	1.3	-3.0	0.0	0.0	24.4	0.0	0.0	-7.3
658	441830.07	5025404.94	79.90	0	D	A	71.8	0.7	0.0	0.0	0.0	56.7	1.3	-3.0	0.0	0.0	24.4	0.0	0.0	-6.9
668	441829.66	5025406.01	79.90	0	D	A	71.8	0.5	0.0	0.0	0.0	56.7	1.3	-3.0	0.0	0.0	24.4	0.0	0.0	-7.2
674	441829.24	5025407.10	79.91	0	D	A	71.8	0.9	0.0	0.0	0.0	56.7	1.3	-3.0	0.0	0.0	24.4	0.0	0.0	-6.8
702	441828.84	5025408.16	79.92	0	D	A	71.8	0.2	0.0	0.0	0.0	56.7	1.3	-3.0	0.0	0.0	24.4	0.0	0.0	-7.5
713	441828.44	5025409.19	79.92	0	D	A	71.8	0.6	0.0	0.0	0.0	56.8	1.3	-3.0	0.0	0.0	24.4	0.0	0.0	-7.1
721	441828.14	5025409.98	79.93	0	D	A	71.8	-2.7	0.0	0.0	0.0	56.8	1.3	-3.0	0.0	0.0	24.4	0.0	0.0	-10.4
741	441839.42	5025380.56	79.75	1	D	A	71.8	3.7	0.0	0.0	0.0	57.8	1.4	-3.0	0.0	0.0	24.3	0.0	2.6	-7.7
744	441838.79	5025382.21	79.76	1	D	A	71.8	0.8	0.0	0.0	0.0	57.8	1.4	-3.0	0.0	0.0	24.3	0.0	2.6	-10.5
751	441838.37	5025383.30	79.77	1	D	A	71.8	0.5	0.0	0.0	0.0	57.8	1.4	-3.0	0.0	0.0	24.3	0.0	2.6	-10.9
758	441837.98	5025384.32	79.77	1	D	A	71.8	0.3	0.0	0.0	0.0	57.8	1.4	-3.0	0.0	0.0	24.3	0.0	2.6	-11.1
773	441837.59	5025385.35	79.78	1	D	A	71.8	0.6	0.0	0.0	0.0	57.8	1.4	-3.0	0.0	0.0	24.3	0.0	2.6	-10.8
782	441837.16	5025386.45	79.79	1	D	A	71.8	0.9	0.0	0.0	0.0	57.8	1.4	-3.0	0.0	0.0	24.3	0.0	2.6	-10.5
793	441836.64	5025387.81	79.79	1	D	A	71.8	2.3	0.0	0.0	0.0	57.8	1.4	-3.0	0.0	0.0	24.3	0.0	2.6	-9.1
848	441839.09	5025381.43	79.76	1	D	A	71.8	0.9	0.0	0.0	0.0	56.5	1.3	-3.0	0.0	0.0	24.8	0.0	4.0	-10.9
2070	441827.35	5025409.97	79.94	0	D	A	71.8	1.7	0.0	0.0	0.0	56.8	1.3	-3.0	0.0	0.0	24.4	0.0	0.0	-6.1
2079	441825.25	5025409.17	79.97	0	D	A	71.8	4.8	0.0	0.0	0.0	56.9	1.3	-3.0	0.0	0.0	24.4	0.0	0.0	-3.0
2088	441823.18	5025408.39	80.00	0	D	A	71.8	1.4	0.0	0.0	0.0	57.0	1.3	-3.0	0.0	0.0	24.3	0.0	0.0	-6.5
2098	441821.40	5025407.71	80.03	0	D	A	71.8	3.8	0.0	0.0	0.0	57.1	1.3	-3.0	0.0	0.0	24.3	0.0	0.0	-4.1
2107	441819.36	5025406.93	80.06	0	D	A	71.8	2.9	0.0	0.0	0.0	57.2	1.4	-3.0	0.0	0.0	24.3	0.0	0.0	-5.1
2115	441817.57	5025406.25	80.08	0	D	A	71.8	2.7	0.0	0.0	0.0	57.2	1.4	-3.0	0.0	0.0	24.2	0.0	0.0	-5.4
2125	441816.18	5025405.73	80.10	0	D	A	71.8	0.4	0.0	0.0	0.0	57.3	1.4	-3.0	0.0	0.0	24.2	0.0	0.0	-7.7
2133	441815.12	5025405.33	80.12	0	D	A	71.8	0.7	0.0	0.0	0.0	57.4	1.4	-3.0	0.0	0.0	24.2	0.0	0.0	-7.5
2142	441813.82	5025404.83	80.14	0	D	A	71.8	2.1	0.0	0.0	0.0	57.4	1.4	-3.0	0.0	0.0	24.1	0.0	0.0	-6.1
2152	441812.16	5025404.20	80.16	0	D	A	71.8	2.9	0.0	0.0	0.0	57.5	1.4	-3.0	0.0	0.0	24.1	0.0	0.0	-5.3
2162	441810.63	5025403.62	80.19	0	D	A	71.8	1.2	0.0	0.0	0.0	57.5	1.4	-3.0	0.0	0.0	24.1	0.0	0.0	-7.0
2172	441809.21	5025403.08	80.21	0	D	A	71.8	2.4	0.0	0.0	0.0	57.6	1.4	-3.0	0.0	0.0	24.0	0.0	0.0	-5.9
2181	441807.46	5025402.41	80.23	0	D	A	71.8	3.0	0.0	0.0	0.0	57.7	1.4	-3.0	0.0	0.0	24.0	0.0	0.0	-5.3
2190	441805.89	5025401.82	80.26	0	D	A	71.8	1.3	0.0	0.0	0.0	57.7	1.4	-3.0	0.0	0.0	24.0	0.0	0.0	-7.1
2200	441804.46	5025401.28	80.28	0	D	A	71.8	2.3	0.0	0.0	0.0	57.8	1.4	-3.0	0.0	0.0	23.9	0.0	0.0	-6.1

Sample CADNA/A Calculation at Receptor

Line Source, ISO 9613, Name: "Truck Movement to Building B", ID: "SS_TRKM_01"																				
Nr.	X	Y	Z	Refl.	DEN	Freq.	Lw	l/a	Optime	K0	Di	Adiv	Aatm	Agr	Afol	Ahous	Abar	Cmet	RL	Lr
	(m)	(m)	(m)			(Hz)	dB(A)	dB	dB	(dB)	(dB)	(dB)	(dB)	(dB)	(dB)	(dB)	(dB)	(dB)	(dB)	dB(A)
2209	441802.99	5025400.72	80.30	0	D	A	71.8	1.6	0.0	0.0	0.0	57.9	1.4	-3.0	0.0	0.0	23.8	0.0	0.0	-6.8
2219	441801.04	5025399.98	80.33	0	D	A	71.8	4.3	0.0	0.0	0.0	57.9	1.5	-3.0	0.0	0.0	23.6	0.0	0.0	-3.9
2228	441798.96	5025399.19	80.36	0	D	A	71.8	2.4	0.0	0.0	0.0	58.0	1.5	-3.0	0.0	0.0	24.4	0.0	0.0	-6.7
2254	441806.84	5025402.18	80.24	1	D	A	71.8	1.9	0.0	0.0	0.0	58.7	1.6	-3.1	0.0	0.0	24.4	0.0	2.5	-10.4
2269	441804.13	5025401.15	80.28	1	D	A	71.8	3.4	0.0	0.0	0.0	58.6	1.5	-3.0	0.0	0.0	24.4	0.0	2.5	-8.9
2277	441802.49	5025400.52	80.31	1	D	A	71.8	1.3	0.0	0.0	0.0	58.5	1.5	-3.0	0.0	0.0	24.5	0.0	2.1	-10.6
2295	441800.15	5025399.64	80.34	1	D	A	71.8	1.4	0.0	0.0	0.0	58.4	1.5	-3.0	0.0	0.0	24.5	0.0	2.1	-10.4
2304	441798.91	5025399.17	80.36	1	D	A	71.8	1.0	0.0	0.0	0.0	58.4	1.5	-3.0	0.0	0.0	24.5	0.0	2.0	-10.7
2328	441826.64	5025400.79	79.91	0	D	A	71.8	0.5	0.0	0.0	0.0	56.9	1.3	-3.0	0.0	0.0	24.2	0.0	0.0	-7.2
2338	441827.06	5025399.67	79.91	0	D	A	71.8	1.0	0.0	0.0	0.0	56.9	1.3	-3.0	0.0	0.0	24.2	0.0	0.0	-6.6
2349	441827.51	5025398.48	79.90	0	D	A	71.8	1.0	0.0	0.0	0.0	56.9	1.3	-3.0	0.0	0.0	24.2	0.0	0.0	-6.5
2360	441827.92	5025397.38	79.90	0	D	A	71.8	0.3	0.0	0.0	0.0	56.9	1.3	-3.0	0.0	0.0	24.1	0.0	0.0	-7.2
2369	441828.32	5025396.32	79.90	0	D	A	71.8	0.7	0.0	0.0	0.0	56.8	1.3	-3.0	0.0	0.0	24.1	0.0	0.0	-6.8
2379	441828.70	5025395.29	79.89	0	D	A	71.8	0.0	0.0	0.0	0.0	56.8	1.3	-3.0	0.0	0.0	24.1	0.0	0.0	-7.4
2388	441829.10	5025394.23	79.89	0	D	A	71.8	1.0	0.0	0.0	0.0	56.8	1.3	-3.0	0.0	0.0	24.0	0.0	0.0	-6.4
2398	441829.50	5025393.16	79.88	0	D	A	71.8	0.1	0.0	0.0	0.0	56.8	1.3	-3.0	0.0	0.0	24.0	0.0	0.0	-7.2
2408	441829.91	5025392.06	79.88	0	D	A	71.8	1.1	0.0	0.0	0.0	56.8	1.3	-3.0	0.0	0.0	23.9	0.0	0.0	-6.2
2417	441830.35	5025390.88	79.87	0	D	A	71.8	0.9	0.0	0.0	0.0	56.8	1.3	-3.0	0.0	0.0	23.9	0.0	0.0	-6.4
2428	441830.75	5025389.81	79.87	0	D	A	71.8	0.2	0.0	0.0	0.0	56.8	1.3	-3.0	0.0	0.0	23.9	0.0	0.0	-7.0
2438	441831.11	5025388.84	79.86	0	D	A	71.8	0.1	0.0	0.0	0.0	56.8	1.3	-3.0	0.0	0.0	23.8	0.0	0.0	-7.1
2448	441831.50	5025387.80	79.86	0	D	A	71.8	0.8	0.0	0.0	0.0	56.8	1.3	-3.0	0.0	0.0	23.8	0.0	0.0	-6.3
2456	441831.92	5025386.67	79.85	0	D	A	71.8	0.8	0.0	0.0	0.0	56.8	1.3	-3.0	0.0	0.0	23.7	0.0	0.0	-6.3
2466	441832.43	5025385.30	79.85	0	D	A	71.8	2.4	0.0	0.0	0.0	56.8	1.3	-3.0	0.0	0.0	23.7	0.0	0.0	-4.6
2477	441832.96	5025383.88	79.84	0	D	A	71.8	1.2	0.0	0.0	0.0	56.8	1.3	-3.0	0.0	0.0	23.6	0.0	0.0	-5.7
2487	441833.38	5025382.77	79.84	0	D	A	71.8	0.3	0.0	0.0	0.0	56.8	1.3	-3.0	0.0	0.0	23.4	0.0	0.0	-6.4
2497	441833.74	5025381.80	79.83	0	D	A	71.8	0.0	0.0	0.0	0.0	56.7	1.3	-3.0	0.0	0.0	23.3	0.0	0.0	-6.6
2507	441834.13	5025380.77	79.83	0	D	A	71.8	0.8	0.0	0.0	0.0	56.7	1.3	-3.0	0.0	0.0	23.3	0.0	0.0	-5.8
2516	441834.54	5025379.67	79.82	0	D	A	71.8	0.6	0.0	0.0	0.0	56.7	1.3	-3.0	0.0	0.0	23.1	0.0	0.0	-5.8
2525	441834.92	5025378.63	79.82	0	D	A	71.8	0.3	0.0	0.0	0.0	56.7	1.3	-3.0	0.0	0.0	23.1	0.0	0.0	-6.1
2534	441835.29	5025377.64	79.81	0	D	A	71.8	0.3	0.0	0.0	0.0	56.7	1.3	-3.0	0.0	0.0	23.0	0.0	0.0	-6.0
2543	441835.72	5025376.49	79.81	0	D	A	71.8	1.4	0.0	0.0	0.0	56.7	1.3	-3.0	0.0	0.0	23.0	0.0	0.0	-4.8
2551	441836.16	5025375.32	79.80	0	D	A	71.8	0.5	0.0	0.0	0.0	56.7	1.3	-3.0	0.0	0.0	22.9	0.0	0.0	-5.6
2561	441836.54	5025374.32	79.80	0	D	A	71.8	0.0	0.0	0.0	0.0	56.7	1.3	-3.0	0.0	0.0	22.8	0.0	0.0	-6.1
2572	441836.90	5025373.35	79.80	0	D	A	71.8	0.2	0.0	0.0	0.0	56.7	1.3	-3.0	0.0	0.0	22.8	0.0	0.0	-5.8
2582	441837.18	5025372.60	79.79	0	D	A	71.8	-2.5	0.0	0.0	0.0	56.7	1.3	-3.0	0.0	0.0	22.7	0.0	0.0	-8.4
2596	441832.67	5025384.65	79.84	1	D	A	71.8	0.4	0.0	0.0	0.0	57.6	1.4	-3.0	0.0	0.0	24.4	0.0	2.1	-10.4
2603	441833.09	5025383.55	79.84	1	D	A	71.8	1.0	0.0	0.0	0.0	57.6	1.4	-3.0	0.0	0.0	24.4	0.0	2.1	-9.8
2612	441833.58	5025382.23	79.83	1	D	A	71.8	1.9	0.0	0.0	0.0	57.6	1.4	-3.0	0.0	0.0	24.4	0.0	2.1	-8.8
2621	441834.06	5025380.94	79.83	1	D	A	71.8	0.7	0.0	0.0	0.0	57.6	1.4	-3.0	0.0	0.0	24.4	0.0	2.1	-10.0
2630	441834.48	5025379.83	79.82	1	D	A	71.8	0.7	0.0	0.0	0.0	57.6	1.4	-3.0	0.0	0.0	24.4	0.0	2.1	-10.0
2636	441834.95	5025378.56	79.82	1	D	A	71.8	1.9	0.0	0.0	0.0	57.6	1.4	-3.0	0.0	0.0	24.4	0.0	2.1	-8.9
2644	441835.44	5025377.25	79.81	1	D	A	71.8	1.0	0.0	0.0	0.0	57.6	1.4	-3.0	0.0	0.0	24.4	0.0	2.1	-9.7
2663	441836.22	5025375.17	79.80	1	D	A	71.8	1.2	0.0	0.0	0.0	58.1	1.5	-3.0	0.0	0.0	24.2	0.0	2.6	-10.5
2681	441837.00	5025373.08	79.80	1	D	A	71.8	0.5	0.0	0.0	0.0	58.1	1.5	-3.0	0.0	0.0	23.9	0.0	2.8	-11.0
2783	441801.58	5025391.92	80.22	0	D	A	71.8	1.6	0.0	0.0	0.0	58.0	1.5	-3.0	0.0	0.0	24.4	0.0	0.0	-7.5
2792	441802.97	5025392.44	80.20	0	D	A	71.8	1.8	0.0	0.0	0.0	57.9	1.5	-3.0	0.0	0.0	24.5	0.0	0.0	-7.3
2800	441804.23	5025392.92	80.18	0	D	A	71.8	0.7	0.0	0.0	0.0	57.9	1.4	-3.0	0.0	0.0	24.5	0.0	0.0	-8.3
2810	441806.52	5025393.78	80.16	0	D	A	71.8	5.7	0.0	0.0	0.0	57.8	1.4	-3.0	0.0	0.0	24.5	0.0	0.0	-3.3
2819	441808.81	5025394.65	80.13	0	D	A	71.8	0.7	0.0	0.0	0.0	57.7	1.4	-3.0	0.0	0.0	24.6	0.0	0.0	-8.3
2829	441810.22	5025395.18	80.11	0	D	A	71.8	2.7	0.0	0.0	0.0	57.6	1.4	-3.0	0.0	0.0	24.6	0.0	0.0	-6.2
2838	441811.86	5025395.80	80.09	0	D	A	71.8	2.2	0.0	0.0	0.0	57.5	1.4	-3.0	0.0	0.0	24.6	0.0	0.0	-6.6
2846	441813.32	5025396.36	80.08	0	D	A	71.8	1.8	0.0	0.0	0.0	57.5	1.4	-3.0	0.0	0.0	23.9	0.0	0.0	-6.3
2854	441814.71	5025396.88	80.06	0	D	A	71.8	1.7	0.0	0.0	0.0	57.4	1.4	-3.0	0.0	0.0	24.0	0.0	0.0	-6.3
2863	441816.65	5025397.61	80.04	0	D	A	71.8	4.3	0.0	0.0	0.0	57.3	1.4	-3.0	0.0	0.0	24.0	0.0	0.0	-3.7
2871	441819.55	5025398.71	80.00	0	D	A	71.8	5.5	0.0	0.0	0.0	57.2	1.4	-3.0	0.0	0.0	24.1	0.0	0.0	-2.4
2880	441822.63	5025399.88	79.96	0	D	A	71.8	4.8	0.0	0.0	0.0	57.1	1.3	-3.0	0.0	0.0	24.1	0.0	0.0	-3.0
2889	441824.84	5025400.71	79.94	0	D	A	71.8	2.3	0.0	0.0	0.0	57.0	1.3	-3.0	0.0	0.0	24.2	0.0	0.0	-5.4
2897	441826.04	5025401.17	79.92	0	D	A	71.8	-0.6	0.0	0.0	0.0	56.9	1.3	-3.0	0.0	0.0	24.2	0.0	0.0	-8.3
2905	441801.71	5025391.97	80.22	1	D	A	71.8	2.4	0.0	0.0	0.0	58.3	1.5	-3.0	0.0	0.0	24.5	0.0	2.0	-9.2
2910	441803.36	5025392.59	80.20	1	D	A	71.8	2.5	0.0	0.0	0.0	58.4	1.5	-3.0	0.0	0.0	24.5	0.0	2.1	-9.2
2916	441805.12	5025393.26	80.17	1	D	A	71.8	3.0	0.0	0.0	0.0	58.5	1.5	-3.0	0.0	0.0	24.5	0.0	2.1	-8.9
2923	441806.96	5025393.95	80.15	1	D	A	71.8	2.9	0.0	0.0	0.0	58.5	1.5	-3.0	0.0	0.0	24.5	0.0	2.1	-9.0
2931	441808.53	5025394.54	80.13	1	D	A	71.8	1.5	0.0	0.0	0.0	58.6	1.5	-3.0	0.0	0.0	24.4	0.0	2.5	-10.8

Sample CADNA/A Calculation at Receptor

Line Source, ISO 9613, Name: "Truck Movement to Building B", ID: "SS_TRKM_01"																				
Nr.	X	Y	Z	Refl.	DEN	Freq.	Lw	l/a	Optime	K0	Di	Adiv	Aatm	Agr	Afol	Ahous	Abar	Cmet	RL	Lr
	(m)	(m)	(m)			(Hz)	dB(A)	dB	dB	(dB)	(dB)	(dB)	(dB)	(dB)	(dB)	(dB)	(dB)	(dB)	(dB)	dB(A)
3034	441798.01	5025398.09	80.36	0	D	A	71.8	1.4	0.0	0.0	0.0	58.1	1.5	-3.0	0.0	0.0	24.4	0.0	0.0	-7.8
3043	441798.61	5025396.75	80.34	0	D	A	71.8	2.0	0.0	0.0	0.0	58.1	1.5	-3.0	0.0	0.0	24.4	0.0	0.0	-7.2
3051	441799.24	5025395.36	80.31	0	D	A	71.8	1.7	0.0	0.0	0.0	58.0	1.5	-3.0	0.0	0.0	24.4	0.0	0.0	-7.5
3060	441799.76	5025394.19	80.28	0	D	A	71.8	0.3	0.0	0.0	0.0	58.0	1.5	-3.0	0.0	0.0	24.4	0.0	0.0	-8.8
3068	441800.25	5025393.10	80.26	0	D	A	71.8	1.2	0.0	0.0	0.0	58.0	1.5	-3.0	0.0	0.0	24.4	0.0	0.0	-7.9
3075	441800.71	5025392.08	80.23	0	D	A	71.8	-0.4	0.0	0.0	0.0	58.0	1.5	-3.0	0.0	0.0	24.4	0.0	0.0	-9.5
3092	441798.43	5025397.16	80.34	1	D	A	71.8	1.0	0.0	0.0	0.0	58.3	1.5	-3.0	0.0	0.0	24.5	0.0	2.0	-10.7
3100	441798.92	5025396.06	80.32	1	D	A	71.8	0.7	0.0	0.0	0.0	58.3	1.5	-3.0	0.0	0.0	24.5	0.0	2.0	-11.0
3108	441799.48	5025394.83	80.29	1	D	A	71.8	1.9	0.0	0.0	0.0	58.3	1.5	-3.0	0.0	0.0	24.5	0.0	2.0	-9.8
3123	441800.47	5025392.61	80.25	1	D	A	71.8	0.6	0.0	0.0	0.0	58.3	1.5	-3.0	0.0	0.0	24.5	0.0	2.0	-11.0

Point Source, ISO 9613, Name: "HVAC 10T Unit", ID: "SS_BLDA_HVAC_01"																				
Nr.	X	Y	Z	Refl.	DEN	Freq.	Lw	l/a	Optime	K0	Di	Adiv	Aatm	Agr	Afol	Ahous	Abar	Cmet	RL	Lr
	(m)	(m)	(m)			(Hz)	dB(A)	dB	dB	(dB)	(dB)	(dB)	(dB)	(dB)	(dB)	(dB)	(dB)	(dB)	(dB)	dB(A)
892	441837.92	5025436.51	100.80	0	D	A	79.9	0.0	0.0	0.0	0.0	56.3	0.4	-3.0	0.0	0.0	8.7	0.0	0.0	17.4
892	441837.92	5025436.51	100.80	0	N	A	79.9	0.0	0.0	0.0	0.0	56.3	0.4	-3.0	0.0	0.0	8.7	0.0	0.0	17.4
895	441837.92	5025436.51	100.80	1	D	A	79.9	0.0	0.0	0.0	0.0	57.3	0.4	-3.0	0.0	0.0	9.2	0.0	2.0	14.0
895	441837.92	5025436.51	100.80	1	N	A	79.9	0.0	0.0	0.0	0.0	57.3	0.4	-3.0	0.0	0.0	9.2	0.0	2.0	14.0
907	441837.92	5025436.51	100.80	1	D	A	79.9	0.0	0.0	0.0	0.0	56.7	0.4	-3.0	0.0	0.0	8.6	0.0	2.0	15.3
907	441837.92	5025436.51	100.80	1	N	A	79.9	0.0	0.0	0.0	0.0	56.7	0.4	-3.0	0.0	0.0	8.6	0.0	2.0	15.3

Point Source, ISO 9613, Name: "Truck Idling at Loading Bay - Bldg A", ID: "SS_TRKI_02"																				
Nr.	X	Y	Z	Refl.	DEN	Freq.	Lw	l/a	Optime	K0	Di	Adiv	Aatm	Agr	Afol	Ahous	Abar	Cmet	RL	Lr
	(m)	(m)	(m)			(Hz)	dB(A)	dB	dB	(dB)	(dB)	(dB)	(dB)	(dB)	(dB)	(dB)	(dB)	(dB)	(dB)	dB(A)
913	441822.65	5025426.57	80.29	0	D	A	98.5	0.0	-10.8	0.0	0.0	57.0	1.0	-3.0	0.0	0.0	24.4	0.0	0.0	8.4

Line Source, ISO 9613, Name: "Truck Movement to Building A (North Side)", ID: "SS_TRKM_02"																				
Nr.	X	Y	Z	Refl.	DEN	Freq.	Lw	l/a	Optime	K0	Di	Adiv	Aatm	Agr	Afol	Ahous	Abar	Cmet	RL	Lr
	(m)	(m)	(m)			(Hz)	dB(A)	dB	dB	(dB)	(dB)	(dB)	(dB)	(dB)	(dB)	(dB)	(dB)	(dB)	(dB)	dB(A)
921	441819.30	5025425.80	80.37	0	D	A	69.3	2.0	0.0	0.0	0.0	57.1	1.3	-3.0	0.0	0.0	24.5	0.0	0.0	-8.6
930	441819.95	5025424.19	80.35	0	D	A	69.3	2.7	0.0	0.0	0.0	57.1	1.3	-3.0	0.0	0.0	24.5	0.0	0.0	-7.8
935	441820.49	5025422.83	80.33	0	D	A	69.3	0.2	0.0	0.0	0.0	57.1	1.3	-3.0	0.0	0.0	24.5	0.0	0.0	-10.4
941	441820.88	5025421.86	80.32	0	D	A	69.3	0.3	0.0	0.0	0.0	57.1	1.3	-3.0	0.0	0.0	24.5	0.0	0.0	-10.3
951	441821.27	5025420.88	80.31	0	D	A	69.3	0.2	0.0	0.0	0.0	57.0	1.3	-3.0	0.0	0.0	24.5	0.0	0.0	-10.4
961	441821.93	5025419.23	80.29	0	D	A	69.3	4.0	0.0	0.0	0.0	57.0	1.3	-3.0	0.0	0.0	24.5	0.0	0.0	-6.5
974	441822.60	5025417.56	80.27	0	D	A	69.3	0.3	0.0	0.0	0.0	57.0	1.3	-3.0	0.0	0.0	24.5	0.0	0.0	-10.1
982	441823.05	5025416.43	80.25	0	D	A	69.3	1.3	0.0	0.0	0.0	57.0	1.3	-3.0	0.0	0.0	24.4	0.0	0.0	-9.1
991	441823.52	5025415.28	80.24	0	D	A	69.3	0.5	0.0	0.0	0.0	57.0	1.3	-3.0	0.0	0.0	24.4	0.0	0.0	-9.9
998	441824.07	5025413.90	80.22	0	D	A	69.3	2.6	0.0	0.0	0.0	56.9	1.3	-3.0	0.0	0.0	24.4	0.0	0.0	-7.7
1005	441824.61	5025412.54	80.20	0	D	A	69.3	0.4	0.0	0.0	0.0	56.9	1.3	-3.0	0.0	0.0	24.4	0.0	0.0	-9.9
1017	441825.04	5025411.48	80.19	0	D	A	69.3	0.8	0.0	0.0	0.0	56.9	1.3	-3.0	0.0	0.0	24.4	0.0	0.0	-9.5
1027	441825.52	5025410.27	80.18	0	D	A	69.3	1.5	0.0	0.0	0.0	56.9	1.3	-3.0	0.0	0.0	24.4	0.0	0.0	-8.8
1038	441825.97	5025409.15	80.16	0	D	A	69.3	0.1	0.0	0.0	0.0	56.9	1.3	-3.0	0.0	0.0	24.4	0.0	0.0	-10.2
1045	441826.40	5025408.10	80.15	0	D	A	69.3	0.9	0.0	0.0	0.0	56.9	1.3	-3.0	0.0	0.0	24.4	0.0	0.0	-9.3
1056	441826.82	5025407.04	80.14	0	D	A	69.3	0.1	0.0	0.0	0.0	56.8	1.3	-3.0	0.0	0.0	24.4	0.0	0.0	-10.1
1070	441827.21	5025406.06	80.12	0	D	A	69.3	0.4	0.0	0.0	0.0	56.8	1.3	-3.0	0.0	0.0	24.3	0.0	0.0	-9.8
1081	441827.62	5025405.04	80.11	0	D	A	69.3	0.5	0.0	0.0	0.0	56.8	1.3	-3.0	0.0	0.0	24.3	0.0	0.0	-9.7
1091	441828.12	5025403.80	80.10	0	D	A	69.3	2.0	0.0	0.0	0.0	56.8	1.3	-3.0	0.0	0.0	24.3	0.0	0.0	-8.1
1101	441828.65	5025402.48	80.08	0	D	A	69.3	1.0	0.0	0.0	0.0	56.8	1.3	-3.0	0.0	0.0	24.3	0.0	0.0	-9.0
1108	441829.13	5025401.28	80.07	0	D	A	69.3	1.3	0.0	0.0	0.0	56.8	1.3	-3.0	0.0	0.0	24.3	0.0	0.0	-8.7
1117	441829.61	5025400.07	80.05	0	D	A	69.3	1.0	0.0	0.0	0.0	56.8	1.3	-3.0	0.0	0.0	24.2	0.0	0.0	-9.0
1127	441830.08	5025398.90	80.04	0	D	A	69.3	1.0	0.0	0.0	0.0	56.8	1.3	-3.0	0.0	0.0	24.2	0.0	0.0	-8.9
1137	441830.52	5025397.81	80.02	0	D	A	69.3	0.3	0.0	0.0	0.0	56.7	1.3	-3.0	0.0	0.0	24.2	0.0	0.0	-9.6
1143	441830.94	5025396.77	80.01	0	D	A	69.3	0.7	0.0	0.0	0.0	56.7	1.3	-3.0	0.0	0.0	24.1	0.0	0.0	-9.2
1150	441831.34	5025395.77	80.00	0	D	A	69.3	0.0	0.0	0.0	0.0	56.7	1.3	-3.0	0.0	0.0	24.1	0.0	0.0	-9.8
1157	441831.76	5025394.72	79.99	0	D	A	69.3	1.0	0.0	0.0	0.0	56.7	1.3	-3.0	0.0	0.0	24.1	0.0	0.0	-8.8
1167	441832.18	5025393.67	79.97	0	D	A	69.3	0.1	0.0	0.0	0.0	56.7	1.3	-3.0	0.0	0.0	24.0	0.0	0.0	-9.6
1178	441832.61	5025392.60	79.96	0	D	A	69.3	1.1	0.0	0.0	0.0	56.7	1.3	-3.0	0.0	0.0	24.0	0.0	0.0	-8.6
1193	441833.08	5025391.43	79.95	0	D	A	69.3	0.9	0.0	0.0	0.0	56.7	1.3	-3.0	0.0	0.0	24.0	0.0	0.0	-8.7
1203	441833.50	5025390.39	79.93	0	D	A	69.3	0.2	0.0	0.0	0.0	56.7	1.3	-3.0	0.0	0.0	23.9	0.0	0.0	-9.4
1213	441833.88	5025389.44	79.92	0	D	A	69.3	0.0	0.0	0.0	0.0	56.7	1.3	-3.0	0.0	0.0	23.9	0.0	0.0	-9.4
1222	441834.29	5025388.42	79.91	0	D	A	69.3	0.8	0.0	0.0	0.0	56.7	1.3	-3.0	0.0	0.0	23.8	0.0	0.0	-8.7
1233	441834.73	5025387.31	79.89	0	D	A	69.3	0.7	0.0	0.0	0.0	56.6	1.3	-3.0	0.0	0.0	23.8	0.0	0.0	-8.6
1243	441835.27	5025385.97	79.88	0	D	A	69.3	2.3	0.0	0.0	0.0	56.6	1.3	-3.0	0.0	0.0	23.7	0.0	0.0	-7.0

Line Source, ISO 9613, Name: "Truck Movement to Building A (North Side)", ID: "SS_TRKM_02"																				
Nr.	X	Y	Z	Refl.	DEN	Freq.	Lw	l/a	Optime	K0	Di	Adiv	Aatm	Agr	Afol	Ahous	Abar	Cmet	RL	Lr
	(m)	(m)	(m)			(Hz)	dB(A)	dB	dB	(dB)	(dB)	(dB)	(dB)	(dB)	(dB)	(dB)	(dB)	(dB)	(dB)	dB(A)
1252	441835.82	5025384.58	79.86	0	D	A	69.3	1.1	0.0	0.0	0.0	56.6	1.3	-3.0	0.0	0.0	23.6	0.0	0.0	-8.1
1260	441836.26	5025383.49	79.85	0	D	A	69.3	0.2	0.0	0.0	0.0	56.6	1.3	-3.0	0.0	0.0	23.4	0.0	0.0	-8.8
1269	441836.68	5025382.44	79.83	0	D	A	69.3	0.8	0.0	0.0	0.0	56.6	1.3	-3.0	0.0	0.0	23.4	0.0	0.0	-8.2
1276	441837.11	5025381.36	79.82	0	D	A	69.3	0.5	0.0	0.0	0.0	56.6	1.3	-3.0	0.0	0.0	23.3	0.0	0.0	-8.3
1286	441837.59	5025380.17	79.81	0	D	A	69.3	1.6	0.0	0.0	0.0	56.6	1.3	-3.0	0.0	0.0	23.3	0.0	0.0	-7.3
1296	441838.06	5025378.99	79.79	0	D	A	69.3	0.5	0.0	0.0	0.0	56.6	1.3	-3.0	0.0	0.0	23.1	0.0	0.0	-8.2
1306	441838.62	5025377.60	79.78	0	D	A	69.3	2.8	0.0	0.0	0.0	56.6	1.3	-3.0	0.0	0.0	23.1	0.0	0.0	-5.8
1315	441839.18	5025376.20	79.76	0	D	A	69.3	0.5	0.0	0.0	0.0	56.6	1.3	-3.0	0.0	0.0	23.0	0.0	0.0	-8.0
1325	441839.56	5025375.27	79.75	0	D	A	69.3	-0.4	0.0	0.0	0.0	56.6	1.3	-3.0	0.0	0.0	22.9	0.0	0.0	-8.9
1497	441838.08	5025374.47	79.77	0	D	A	69.3	1.9	0.0	0.0	0.0	56.6	1.3	-3.0	0.0	0.0	22.8	0.0	0.0	-6.5
1506	441837.61	5025375.73	79.79	0	D	A	69.3	0.6	0.0	0.0	0.0	56.7	1.3	-3.0	0.0	0.0	22.9	0.0	0.0	-8.0
1516	441837.17	5025376.91	79.80	0	D	A	69.3	1.4	0.0	0.0	0.0	56.7	1.3	-3.0	0.0	0.0	23.0	0.0	0.0	-7.3
1525	441836.75	5025378.04	79.82	0	D	A	69.3	0.2	0.0	0.0	0.0	56.7	1.3	-3.0	0.0	0.0	23.1	0.0	0.0	-8.4
1534	441836.38	5025379.03	79.83	0	D	A	69.3	0.2	0.0	0.0	0.0	56.7	1.3	-3.0	0.0	0.0	23.1	0.0	0.0	-8.5
1543	441836.00	5025380.06	79.84	0	D	A	69.3	0.5	0.0	0.0	0.0	56.7	1.3	-3.0	0.0	0.0	23.2	0.0	0.0	-8.3
1552	441835.59	5025381.15	79.85	0	D	A	69.3	0.7	0.0	0.0	0.0	56.7	1.3	-3.0	0.0	0.0	23.3	0.0	0.0	-8.2
1562	441835.18	5025382.25	79.87	0	D	A	69.3	0.7	0.0	0.0	0.0	56.7	1.3	-3.0	0.0	0.0	23.4	0.0	0.0	-8.3
1571	441834.76	5025383.36	79.88	0	D	A	69.3	0.8	0.0	0.0	0.0	56.7	1.3	-3.0	0.0	0.0	23.6	0.0	0.0	-8.4
1581	441834.13	5025385.05	79.90	0	D	A	69.3	3.8	0.0	0.0	0.0	56.7	1.3	-3.0	0.0	0.0	23.7	0.0	0.0	-5.5
1589	441833.53	5025386.66	79.92	0	D	A	69.3	0.2	0.0	0.0	0.0	56.7	1.3	-3.0	0.0	0.0	23.7	0.0	0.0	-9.2
1597	441833.16	5025387.66	79.93	0	D	A	69.3	0.3	0.0	0.0	0.0	56.7	1.3	-3.0	0.0	0.0	23.8	0.0	0.0	-9.2
1608	441832.78	5025388.67	79.94	0	D	A	69.3	0.4	0.0	0.0	0.0	56.7	1.3	-3.0	0.0	0.0	23.8	0.0	0.0	-9.1
1617	441832.40	5025389.70	79.95	0	D	A	69.3	0.4	0.0	0.0	0.0	56.7	1.3	-3.0	0.0	0.0	23.9	0.0	0.0	-9.2
1626	441831.99	5025390.80	79.97	0	D	A	69.3	1.0	0.0	0.0	0.0	56.7	1.3	-3.0	0.0	0.0	23.9	0.0	0.0	-8.6
1635	441831.57	5025391.93	79.98	0	D	A	69.3	0.6	0.0	0.0	0.0	56.7	1.3	-3.0	0.0	0.0	24.0	0.0	0.0	-9.1
1645	441831.18	5025392.97	79.99	0	D	A	69.3	0.4	0.0	0.0	0.0	56.7	1.3	-3.0	0.0	0.0	24.0	0.0	0.0	-9.3
1656	441830.77	5025394.05	80.00	0	D	A	69.3	0.8	0.0	0.0	0.0	56.8	1.3	-3.0	0.0	0.0	24.0	0.0	0.0	-8.9
1667	441830.37	5025395.13	80.02	0	D	A	69.3	0.3	0.0	0.0	0.0	56.8	1.3	-3.0	0.0	0.0	24.1	0.0	0.0	-9.5
1677	441829.95	5025396.26	80.03	0	D	A	69.3	1.3	0.0	0.0	0.0	56.8	1.3	-3.0	0.0	0.0	24.1	0.0	0.0	-8.6
1687	441829.52	5025397.41	80.04	0	D	A	69.3	0.5	0.0	0.0	0.0	56.8	1.3	-3.0	0.0	0.0	24.1	0.0	0.0	-9.4
1697	441829.13	5025398.47	80.06	0	D	A	69.3	0.6	0.0	0.0	0.0	56.8	1.3	-3.0	0.0	0.0	24.2	0.0	0.0	-9.4
1707	441828.66	5025399.72	80.07	0	D	A	69.3	1.8	0.0	0.0	0.0	56.8	1.3	-3.0	0.0	0.0	24.2	0.0	0.0	-8.2
1717	441828.15	5025401.09	80.09	0	D	A	69.3	1.5	0.0	0.0	0.0	56.8	1.3	-3.0	0.0	0.0	24.2	0.0	0.0	-8.6
1726	441827.68	5025402.35	80.10	0	D	A	69.3	1.0	0.0	0.0	0.0	56.8	1.3	-3.0	0.0	0.0	24.3	0.0	0.0	-9.1
1735	441827.27	5025403.45	80.11	0	D	A	69.3	0.4	0.0	0.0	0.0	56.8	1.3	-3.0	0.0	0.0	24.3	0.0	0.0	-9.7
1744	441826.87	5025404.53	80.13	0	D	A	69.3	0.8	0.0	0.0	0.0	56.9	1.3	-3.0	0.0	0.0	24.3	0.0	0.0	-9.4
1752	441826.46	5025405.62	80.14	0	D	A	69.3	0.5	0.0	0.0	0.0	56.9	1.3	-3.0	0.0	0.0	24.3	0.0	0.0	-9.7
1760	441826.05	5025406.73	80.15	0	D	A	69.3	0.9	0.0	0.0	0.0	56.9	1.3	-3.0	0.0	0.0	24.3	0.0	0.0	-9.3
1769	441825.64	5025407.80	80.17	0	D	A	69.3	0.2	0.0	0.0	0.0	56.9	1.3	-3.0	0.0	0.0	24.4	0.0	0.0	-10.0
1778	441825.25	5025408.85	80.18	0	D	A	69.3	0.7	0.0	0.0	0.0	56.9	1.3	-3.0	0.0	0.0	24.4	0.0	0.0	-9.6
1788	441824.85	5025409.93	80.19	0	D	A	69.3	0.5	0.0	0.0	0.0	56.9	1.3	-3.0	0.0	0.0	24.4	0.0	0.0	-9.8
1797	441824.48	5025410.93	80.20	0	D	A	69.3	0.0	0.0	0.0	0.0	56.9	1.3	-3.0	0.0	0.0	24.4	0.0	0.0	-10.3
1806	441824.07	5025412.02	80.22	0	D	A	69.3	1.2	0.0	0.0	0.0	56.9	1.3	-3.0	0.0	0.0	24.4	0.0	0.0	-9.1
1815	441823.53	5025413.46	80.23	0	D	A	69.3	2.5	0.0	0.0	0.0	57.0	1.3	-3.0	0.0	0.0	24.4	0.0	0.0	-7.9
1824	441823.01	5025414.87	80.25	0	D	A	69.3	0.9	0.0	0.0	0.0	57.0	1.3	-3.0	0.0	0.0	24.4	0.0	0.0	-9.5
1833	441822.50	5025416.23	80.26	0	D	A	69.3	2.3	0.0	0.0	0.0	57.0	1.3	-3.0	0.0	0.0	24.4	0.0	0.0	-8.2
1842	441822.02	5025417.52	80.28	0	D	A	69.3	0.3	0.0	0.0	0.0	57.0	1.3	-3.0	0.0	0.0	24.4	0.0	0.0	-10.2
1853	441821.48	5025418.97	80.30	0	D	A	69.3	3.0	0.0	0.0	0.0	57.0	1.3	-3.0	0.0	0.0	24.5	0.0	0.0	-7.5
1862	441820.86	5025420.63	80.32	0	D	A	69.3	1.9	0.0	0.0	0.0	57.1	1.3	-3.0	0.0	0.0	24.5	0.0	0.0	-8.7
1872	441820.41	5025421.84	80.33	0	D	A	69.3	0.2	0.0	0.0	0.0	57.1	1.3	-3.0	0.0	0.0	24.5	0.0	0.0	-10.3
1882	441820.04	5025422.82	80.34	0	D	A	69.3	0.1	0.0	0.0	0.0	57.1	1.3	-3.0	0.0	0.0	24.5	0.0	0.0	-10.4
1893	441819.66	5025423.85	80.35	0	D	A	69.3	0.7	0.0	0.0	0.0	57.1	1.3	-3.0	0.0	0.0	24.5	0.0	0.0	-9.9
1904	441819.14	5025425.23	80.37	0	D	A	69.3	2.5	0.0	0.0	0.0	57.1	1.3	-3.0	0.0	0.0	24.5	0.0	0.0	-8.2
1936	441836.42	5025378.93	79.83	1	D	A	69.3	3.6	0.0	0.0	0.0	57.6	1.4	-3.0	0.0	0.0	24.4	0.0	2.1	-9.6
1988	441833.74	5025386.11	79.91	1	D	A	69.3	2.2	0.0	0.0	0.0	57.7	1.4	-3.0	0.0	0.0	24.4	0.0	2.1	-11.0
3141	441819.59	5025427.10	80.37	0	D	A	69.3	3.3	0.0	0.0	0.0	57.1	1.3	-3.0	0.0	0.0	24.5	0.0	0.0	-7.3
3150	441821.21	5025427.80	80.34	0	D	A	69.3	1.4	0.0	0.0	0.0	57.0	1.3	-3.0	0.0	0.0	24.5	0.0	0.0	-9.2
3157	441822.34	5025428.29	80.33	0	D	A	69.3	0.4	0.0	0.0	0.0	57.0	1.3	-3.0	0.0	0.0	24.5	0.0	0.0	-10.1
3164	441824.56	5025429.25	80.29	0	D	A	69.3	5.7	0.0	0.0	0.0	56.9	1.3	-3.0	0.0	0.0	24.6	0.0	0.0	-4.7
3177	441825.10	5025429.43	80.28	0	D	A	69.3	4.2	0.0	0.0	0.0	56.9	1.3	-3.0	0.0	0.0	24.6	0.0	0.0	-6.2
3185	441823.08	5025428.47	80.31	0	D	A	69.3	2.7	0.0	0.0	0.0	57.0	1.3	-3.0	0.0	0.0	24.5	0.0	0.0	-7.8
3192	441821.67	5025427.81	80.33	0	D	A	69.3	1.0	0.0	0.0	0.0	57.0	1.3	-3.0	0.0	0.0	24.5	0.0	0.0	-9.5
3200	441820.05	5025427.04	80.36	0	D	A	69.3	3.6	0.0	0.0	0.0	57.1	1.3	-3.0	0.0	0.0	24.5	0.0	0.0	-7.0

Sample CADNA/A Calculation at Receptor

Point Source, ISO 9613, Name: "Truck Idling at Loading Bay - Bldg B", ID: "SS_TRKI_03"																				
Nr.	X	Y	Z	Refl.	DEN	Freq.	Lw	l/a	Optime	K0	Di	Adiv	Aatm	Agr	Afol	Ahous	Abar	Cmet	RL	Lr
	(m)	(m)	(m)			(Hz)	dB(A)	dB	dB	(dB)	(dB)	(dB)	(dB)	(dB)	(dB)	(dB)	(dB)	(dB)	(dB)	dB(A)
2756	441801.33	5025399.16	80.32	0	D	A	98.5	0.0	-10.8	0.0	0.0	57.9	1.1	-3.0	0.0	0.0	24.1	0.0	0.0	7.6
2764	441801.33	5025399.16	80.32	1	D	A	98.5	0.0	-10.8	0.0	0.0	58.5	1.2	-3.0	0.0	0.0	24.1	0.0	2.2	4.8

Point Source, ISO 9613, Name: "HVAC 10T Unit", ID: "SS_BLDB_HVAC_03"																				
Nr.	X	Y	Z	Refl.	DEN	Freq.	Lw	l/a	Optime	K0	Di	Adiv	Aatm	Agr	Afol	Ahous	Abar	Cmet	RL	Lr
	(m)	(m)	(m)			(Hz)	dB(A)	dB	dB	(dB)	(dB)	(dB)	(dB)	(dB)	(dB)	(dB)	(dB)	(dB)	(dB)	dB(A)
2774	441817.10	5025375.32	87.29	0	D	A	79.9	0.0	0.0	0.0	0.0	57.5	0.4	-3.0	0.0	0.0	12.8	0.0	0.0	12.2
2774	441817.10	5025375.32	87.29	0	N	A	79.9	0.0	0.0	0.0	0.0	57.5	0.4	-3.0	0.0	0.0	12.8	0.0	0.0	12.2

Point Source, ISO 9613, Name: "HVAC 10T Unit", ID: "SS_BLDB_HVAC_02"																				
Nr.	X	Y	Z	Refl.	DEN	Freq.	Lw	l/a	Optime	K0	Di	Adiv	Aatm	Agr	Afol	Ahous	Abar	Cmet	RL	Lr
	(m)	(m)	(m)			(Hz)	dB(A)	dB	dB	(dB)	(dB)	(dB)	(dB)	(dB)	(dB)	(dB)	(dB)	(dB)	(dB)	dB(A)
2954	441800.25	5025369.82	87.29	0	D	A	79.9	0.0	0.0	0.0	0.0	58.2	0.5	-3.0	0.0	0.0	11.6	0.0	0.0	12.6
2954	441800.25	5025369.82	87.29	0	N	A	79.9	0.0	0.0	0.0	0.0	58.2	0.5	-3.0	0.0	0.0	11.6	0.0	0.0	12.6

Point Source, ISO 9613, Name: "HVAC 10T Unit", ID: "SS_BLDB_HVAC_01"																				
Nr.	X	Y	Z	Refl.	DEN	Freq.	Lw	l/a	Optime	K0	Di	Adiv	Aatm	Agr	Afol	Ahous	Abar	Cmet	RL	Lr
	(m)	(m)	(m)			(Hz)	dB(A)	dB	dB	(dB)	(dB)	(dB)	(dB)	(dB)	(dB)	(dB)	(dB)	(dB)	(dB)	dB(A)
2963	441784.00	5025362.97	87.29	0	D	A	79.9	0.0	0.0	0.0	0.0	58.8	0.5	-3.0	0.0	0.0	10.1	0.0	0.0	13.4
2963	441784.00	5025362.97	87.29	0	N	A	79.9	0.0	0.0	0.0	0.0	58.8	0.5	-3.0	0.0	0.0	10.1	0.0	0.0	13.4

Sound Power Spectra

Name	ID	Type	1/3 Oktave Spectrum (dB)											Source	
			Weight.	31.5	63	125	250	500	1000	2000	4000	8000	A		lin
Large Trucks Delivery	HTRK_MOV	Lw		91	101	101	98	98	97	96	90	86	102.1	106.9	WSP Database
Large Trucks Idling	HTRK_IDLE	Lw		90	101	101	96	96	94	90	86	76	98.5	105.8	WSP Database
10 Ton HVAC Unit	York_10T	Lw	A			73	74	75	72	66	60	50	79.9	90.3	York KDB122 Specs
Forklift	FL_imp	Lw		99.5	102.5	103.5	100.5	97.5	92.5	90.5	89.5	83.5	99.7	108.4	WSP Database