

SERVICING & STORMWATER MANAGEMENT REPORT

2920 SHEFFIELD ROAD

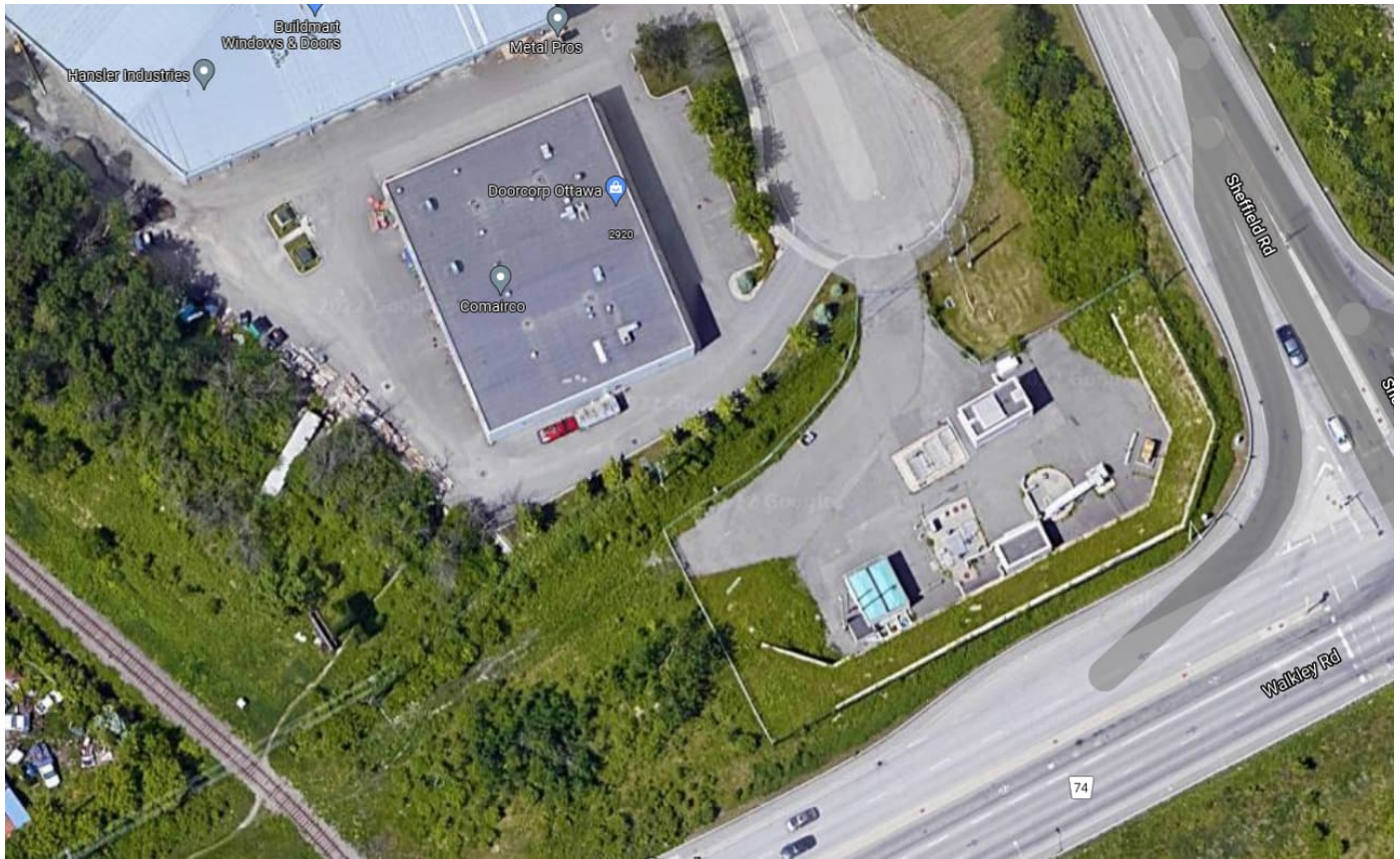

Project No.: CCO-22-0160

City File No.: D07-12-22-0037

Prepared for:

Ross & Anglin Ltd
2920 Sheffield Rd Unit 1
Ottawa, ON
K1B 1A4

Prepared by:

McIntosh Perry Consulting Engineers Ltd.
115 Walgreen Road
Carp, ON K0A 1L0

September 15th, 2022

TABLE OF CONTENTS

1.0	PROJECT DESCRIPTION	1
1.1	<i>Purpose</i>	1
1.2	<i>Site Description</i>	1
1.3	<i>Proposed Development and Statistics</i>	2
1.4	<i>Existing Conditions and Infrastructures</i>	2
1.5	<i>Approvals</i>	2
2.0	BACKGROUND STUDIES, STANDARDS, AND REFERENCES.....	3
2.1	<i>Background Reports / Reference Information</i>	3
2.2	<i>Applicable Guidelines and Standards</i>	3
3.0	PRE-CONSULTATION SUMMARY	4
4.0	WATERMAIN	5
4.1	<i>Existing Watermain</i>	5
4.2	<i>Proposed Watermain</i>	5
5.0	SANITARY DESIGN	7
5.1	<i>Existing Sanitary Sewer</i>	7
5.2	<i>Proposed Sanitary Sewer</i>	7
6.0	STORM SEWER DESIGN	9
6.1	<i>Existing Storm Sewers</i>	9
6.2	<i>Proposed Storm Sewers</i>	9
7.0	PROPOSED STORMWATER MANAGEMENT	10
7.1	<i>Design Criteria and Methodology</i>	10
7.2	<i>Runoff Calculations</i>	10
7.3	<i>Pre-Development Drainage</i>	11
7.4	<i>Post-Development Drainage</i>	11
7.5	<i>Quality Control</i>	12
8.0	EROSION AND SEDIMENT CONTROL.....	13
8.1	<i>Temporary Measures</i>	13
8.2	<i>Permanent Measures</i>	13

9.0	SUMMARY	14
10.0	RECOMMENDATION	15
11.0	STATEMENT OF LIMITATIONS	16

LIST OF TABLES

Table 1: Water Supply Design Criteria	5
Table 2: Summary of Estimated Water Demand	6
Table 3: Fire Protection Confirmation.....	6
Table 4: Sanitary Design Criteria.....	7
Table 5: Summary of Estimated Sanitary Flow	7
Table 6: Pre-Development Runoff Summary.....	11
Table 7: Post-Development Runoff Summary	11
Table 8: Roof Drainage Summary	12

APPENDICES

Appendix A: Site Location Plan

Appendix B: Background Documents

Appendix C: Watermain Calculations

Appendix D: Sanitary Calculations

Appendix E: Pre-Development Drainage Plan

Appendix F: Post-Development Drainage Plan

Appendix G: Stormwater Management Calculations

Appendix H: City of Ottawa Design Checklist

1.0 PROJECT DESCRIPTION

1.1 Purpose

McIntosh Perry (MP) has been retained by Ross & Anglin LTD to prepare this Servicing and Stormwater Management Report in support of the Site Plan Control process for the proposed development located at 2920 Sheffield Road within the City of Ottawa.

The main purpose of this report is to present a servicing and stormwater management design for the development in accordance with the recommendations and guidelines provided by the City of Ottawa (City), the Rideau Valley Conservation Authority (RVCA), and the Ministry of the Environment, Conservation and Parks (MECP). This report will address the water, sanitary and storm sewer servicing for the development, ensuring that existing and available services will adequately service the proposed development.

This report should be read in conjunction with the following drawings:

- CCO-22-0160, C101 – Grading & Drainage Plan
- CCO-22-0160, C102 – Site Servicing Plan
- CCO-22-0160, C103 – Erosion & Sediment Control Plan
- CCO-22-0160, PRE – Pre-Development Drainage Plan (*Appendix E*)
- CCO-22-0160, POST – Post-Development Drainage Plan (*Appendix F*)

1.2 Site Description

Figure 1: Site Map



The subject property, herein referred to as the site, is located at 2920 Sheffield Road within the Alta Vista ward. The site covers approximately 0.72 ha and is located along Sheffield Road. The site is zoned for Heavy Industrial use (IH). See Site Location Plan in *Appendix 'A'* for more details.

1.3 Proposed Development and Statistics

The proposed development consists of the addition of a 945 m² warehouse building. Parking and drive aisles will be extended from the existing parking lot with access from Sheffield road. Development is proposed within 0.35 ha of the site. Refer to *Site Plan* prepared by ES Architects Inc and included in *Appendix B* for further details.

1.4 Existing Conditions and Infrastructures

The site is currently developed containing an existing 2-storey stone and siding light industrial building with asphalt parking areas. The existing building is serviced via a 50 mm diameter water service and 250 mm diameter storm service connected to the municipal infrastructure within Sheffield Road. Sanitary is serviced via a 150 mm diameter service connected to the 675 mm concrete sanitary sewer located south of the site.

Sewer and watermain mapping collected from the City of Ottawa indicate that the following services exist across the property frontages within the adjacent municipal rights-of-way(s):

- ❖ Sheffield Road
 - 305 mm diameter CI watermain, and
 - 1200 mm diameter concrete storm sewer tributary to Ramsay Creek
- ❖ Walkley Road
 - 305 mm diameter DI watermain, and
 - 675 mm diameter concrete sanitary tributary to the South Ottawa Collector Sewer, and
 - 1500 mm diameter concrete storm tributary to Ramsay Creek

1.5 Approvals

The proposed development is subject to the City of Ottawa site plan control approval process. Site plan control requires the City to review, provided concurrence and approve the engineering design package. Permits to construct can be requested once the City has issued a site plan agreement.

An Environmental Compliance Approval (ECA) through the Ministry of Environment, Conservation and Parks (MECP) is anticipated due to the industrial usage of the site.

2.0 BACKGROUND STUDIES, STANDARDS, AND REFERENCES

2.1 Background Reports / Reference Information

As-built drawings of existing services, provided by the City of Ottawa Information centre, within the vicinity of the proposed site were reviewed in order to identify infrastructure available to service the proposed development.

A topographic survey (21527-21) of the site was completed by AOV and dated October 8th, 2021.

The Site Plan (A001) was prepared by ES Architects and dated August 2021 (*Site Plan*).

A geotechnical report was completed by SNC-Lavalin and dated March 2022.

2.2 Applicable Guidelines and Standards

City of Ottawa:

- ◆ Ottawa Sewer Design Guidelines, City of Ottawa, SDG002, October 2012. (*Ottawa Sewer Guidelines*)
 - Technical Bulletin ISTB-2014-01 City of Ottawa, February 2014. (*ISTB-2014-01*)
 - Technical Bulletin PIEDTB-2016-01 City of Ottawa, September 2016. (*PIEDTB-2016-01*)
 - Technical Bulletin ISTB-2018-01 City of Ottawa, January 2018. (*ISTB-2018-01*)
 - Technical Bulletin ISTB-2018-04 City of Ottawa, March 2018. (*ISTB-2018-04*)
 - Technical Bulletin ISTB-2019-02 City of Ottawa, February 2019. (*ISTB-2019-02*)
- ◆ Ottawa Design Guidelines – Water Distribution City of Ottawa, July 2010. (*Ottawa Water Guidelines*)
 - Technical Bulletin ISD-2010-2 City of Ottawa, December 15, 2010. (*ISD-2010-2*)
 - Technical Bulletin ISDTB-2014-02 City of Ottawa, May 2014. (*ISDTB-2014-02*)
 - Technical Bulletin ISTB-2018-02 City of Ottawa, March 2018. (*ISTB-2018-02*)
 - Technical Bulletin ISTB-2021-03 City of Ottawa, August 2021. (*ISTB-2021-03*)

Ministry of Environment, Conservation and Parks:

- ◆ Stormwater Planning and Design Manual, Ministry of the Environment, March 2003. (*MECP Stormwater Design Manual*)
- ◆ Design Guidelines for Sewage Works, Ministry of the Environment, 2008. (*MECP Sewer Design Guidelines*)

3.0 PRE-CONSULTATION SUMMARY

A pre-consultation meeting was held with City staff on September 2nd, 2021, regarding the proposed site servicing. Specific design parameters to be incorporated within this design include the following:

Pre-development and post-development flows shall be calculated using a time of concentration (T_c) no less than 10 minutes.

Control 5 through 100-year post-development flows to the 5-year pre-development flows with a combined C value to a maximum of 0.50.

Based on direction from the Rideau Valley Conservation Authority (RVCA), quality controls, up to an enhanced level of treatment, are required for this site.

4.0 WATERMAIN

4.1 Existing Watermain

The site is located within the 1E pressure zone, as per the Water Distribution System mapping included in *Appendix C*. There is one municipal fire hydrant on Sheffield Road available to service the development. Based on coordination with City staff, the municipal fire hydrant south of the site is also available to service the development. Refer to *Appendix C* for correspondence with the City.

4.2 Proposed Watermain

It is proposed to service the new building by extending the existing water service from the existing building. Refer to drawing *C102* for a detailed servicing layout.

Table 1, below, summarizes the water supply design criteria obtained from the *Ottawa Water Guidelines* and utilized for the water analysis. Heavy duty industrial flows have been assumed to provide a conservative estimate.

Table 1: Water Supply Design Criteria

Site Area	0.72 ha
Heavy Industrial	55,000 L/gross ha/day
Max Day Peaking Factor	1.5 x avg. day
Peak Hour Peaking Factor	1.8 x max. day

The Fire Underwriters Survey 1999 (FUS) method was utilized to estimate the required fire flow for the site. Fire flow requirements were calculated per City of Ottawa Technical Bulletin *ISTB-2018-02*. The following parameters were coordinated with the architect.

- ❖ Type of construction – Non-Combustible Construction
- ❖ Occupancy Type – Non-Combustible
- ❖ Sprinkler Protection – No Sprinkler System

The results of the calculations yielded a required fire flow of *7,000 L/min* (116.67 L/s). The detailed calculations for the FUS can be found in *Appendix C*.

The city provided the estimated water pressures at both the average day scenario, peak hour scenario, and the max day plus fire flow scenario for the demands indicated by the correspondence in *Appendix C*. Boundary condition results are based on light industrial usage. Demand type has since been revised to heavy industrial usage to provide a more conservative estimate, however this isn't anticipated to have a significant change on the resulting boundary condition results.

Table 2: Summary of Estimated Water Demand

Scenario	Proposed Demands (L/S)	Connection 1 HGL (m H ₂ O)* /kPa
Average Day Demand	0.46	54.1 / 530.8
Maximum Daily + Fire Flow Demand (FUS)	117.36	42.8 / 420.0
Maximum Daily + Fire Flow Demand (OBC)	60.69	47.3 / 464.1
Peak Hourly Demand	1.24	46.0 / 451.4

*Adjusted for an estimated ground elevation of 63.9m above the connection point.

The normal operating pressure range is anticipated to be 451.4 kPa to 530.8 kPa and will not be less than 275 kPa (40 psi) or exceed 689 kPa (100 psi).

To confirm the adequacy of fire flow to protect the proposed development, public fire hydrants within 150 m of the proposed building were analysed per City of Ottawa *ISTB 2018-02* Appendix I Table 1. The results are summarized below.

Table 3: Fire Protection Confirmation

Building	Fire Flow Demand (L/min.)	Fire Hydrant(s) within 75m (5,700 L/min)	Fire Hydrant(s) within 150m (3,800 L/min)	Combined Fire Flow (L/min.)
2920 Sheffield Road	7,000	FH1	FH2	9500

Based on City guidelines (*ISTB-2018-02*), the existing hydrants provide adequate protection for the proposed development. A hydrant coverage figure and correspondence regarding the accessibility and maintenance of FH1 can be found in *Appendix C*.

5.0 SANITARY DESIGN

5.1 Existing Sanitary Sewer

There is an existing 150 mm diameter service connection to the 675mm diameter concrete sanitary sewer located south of the site, which is tributary to the South Ottawa Collector Sewer. The existing service includes a maintenance hole located within the property. No changes are proposed to the existing sanitary sewer system.

5.2 Proposed Sanitary Sewer

A new 150 mm diameter gravity sanitary service will be connected to the existing service at the existing maintenance hole located within the property. Refer to drawing C102 for a detailed servicing layout.

Table 4, below, summarizes the wastewater design criteria identified by the *Ottawa Sewer Guidelines*.

Table 4: Sanitary Design Criteria

Design Parameter	Value
Site Area	0.72 ha
Industrial Area (Heavy)	55,000 L/gross ha/d
Industrial Peaking Factor	6.90
Extraneous Flow Allowance	0.33 L/s/ha

Table 5 below, summarizes the estimated wastewater flow from the proposed development. Refer to *Appendix D* for detailed calculations.

Table 5: Summary of Estimated Sanitary Flow

Design Parameter	Total Flow (L/s)
Total Estimated Average Dry Weather Flow	0.50
Total Estimated Peak Dry Weather Flow	3.21
Total Estimated Peak Wet Weather Flow	3.41

As noted above, the development is proposed to be serviced via the existing 150 mm sanitary service connection to the 675 mm concrete sanitary sewer south of the site. The proposed sanitary system will be connected to the existing system at the existing on-site maintenance hole (MHSA8770). Due to the complexity of the downstream network the City will need to advise of any downstream constraints.

The flow is constricted on the 150 mm sewer between the proposed MH1 and the existing MHSA8770. The full flowing capacity of a 150 mm diameter service at a 0.5% slope is estimated to be 11.23 L/s. Per *Table 5*, a peak wet weather flow of 3.41 L/s will be conveyed within the 150 mm diameter service, therefore the proposed system is sufficient sized for the development.

Based on the servicing plan for the existing building found in *Appendix B*, the existing 150 mm diameter sanitary service has a slope of 1.0% between MHSA8770 and the connection to the main. As demonstrated by the Sanitary Sewer Design Sheet included in *Appendix D*, the existing service has sufficient capacity to accommodate the additional flows from the proposed development.

6.0 STORM SEWER DESIGN

6.1 Existing Storm Sewers

Stormwater runoff from the existing building and parking lot is conveyed through a 250 mm diameter service connection to the 1200 mm diameter concrete storm sewer located within Sheffield Road, tributary to Ramsay Creek. Storm drainage within the proposed development area flows overland towards Sheffield Road through a ditch south of the property. Drainage within the ditch flows east towards a municipal DICB connected to the 1200 mm diameter storm sewer within Sheffield Road.

6.2 Proposed Storm Sewers

The proposed development will be serviced through a new 250 mm service connection to the existing 1500 mm diameter storm sewer south of the site.

Runoff collected on the roof of the proposed building will be stored and controlled internally using 4 roof drains. Roof drains will be used to limit the flow from the roof to the specified allowable release rate. For calculation purposes a Watts Accutrol roof drain was used to estimate a reasonable roof flow. Other products may be specified at detailed building design provided release rates and storage volumes are respected.

Runoff from the proposed surface parking lot and landscaped areas will be directed towards catch basins and catch basins maintenance holes. The storm flow will be treated for quality, stored, and controlled. Storm flows will be controlled by an inlet control device (ICD) to limit the flow to the specified allowable release rate.

Foundation drainage is proposed to be conveyed via a 250 mm storm service connected to the maintenance structure OGS1 without flow attenuation.

See CCO-22-0160 - *POST* include in *Appendix F* of this report for more details. The Stormwater Management design for the subject property will be outlined in *Section 7.0* of this report.

7.0 PROPOSED STORMWATER MANAGEMENT

7.1 Design Criteria and Methodology

As per *Section 6.2*, stormwater management for the proposed development will be provided by catch basin flow attenuation and roof storage. The controlled stormwater flow will be directed to the existing 1500 mm diameter storm sewer south of the site.

In summary, the following design criteria have been employed in developing the stormwater management design for the site as directed by the RVCA and City:

Quality Control

- Based on the RVCA pre-consultation notes, quality controls, up to an enhanced level of treatment, are required for the development.

Quantity Control

- Any storm events greater than the 5-year, up to 100-year, and including 100-year storm event must be detained on site.
- Post-development to be restricted to the 5-year storm event, based on a calculated time of concentration greater than 10 minutes and a combined maximum rational method coefficient of 0.50. Refer to *Section 7.2* for further details.

7.2 Runoff Calculations

Runoff calculations presented in this report are derived using the Rational Method, given as:

$$Q = 2.78CIA \text{ (L/s)}$$

Where:	C	= Runoff coefficient
	I	= Rainfall intensity in mm/hr (City of Ottawa IDF curves)
	A	= Drainage area in hectares

It is recognized that the Rational Method tends to overestimate runoff rates. As a result, the conservative calculation of runoff ensures that any SWM facility sized using this method is expected to function as intended. The following coefficients were used to develop an average C for each area:

Roofs/Concrete/Asphalt	0.90
Undeveloped and Grass	0.20

As per the *City of Ottawa - Sewer Design Guidelines*, the 5-year balanced 'C' value must be increased by 25% for a 100-year storm event to a maximum of 1.0.

7.3 Pre-Development Drainage

It has been assumed that the development area contains no stormwater management controls for flow attenuation. The estimated pre-development peak flows for the 5- and 100-year events are summarized below in *Table 6*. See CCO-22-0160 - *PRE* in *Appendix E* and *Appendix G* for calculations.

Table 6: Pre-Development Runoff Summary

Drainage Area	Area (ha)	Q (L/s)	
		5-Year	100-Year
A1	0.35	30.01	63.24

7.4 Post-Development Drainage

To meet the stormwater objectives, the development will contain flow attenuation via surface storage and rooftop storage.

Based on the criteria listed in *Section 7.1*, the development will be required to restrict flow to the 5-year storm event. It is estimated that the target release rate during the 100-year event will be *30.01 L/s*. See *Appendix G* for calculations.

The proposed site drainage limits are demonstrated on the Post-Development Drainage Area Plan. See CCO-22-0160 - *POST* in *Appendix F* of this report for more details. A summary of the post-development runoff calculations can be found below.

Table 7: Post-Development Runoff Summary

Drainage Area	Area (ha)	5-year Peak Flow (L/s)	100-year Peak Flow (L/s)	100-year Storage Required (m ³)	100-year Storage Available (m ³)
B1	0.04	9.49	18.15	-	-
B2	0.22	10.39	10.59	68.3	73.2
B3	0.09	1.26	1.26	54.2	63.8
Total	0.35	21.14	30.00	122.6	137.03

The flow from Area B1 will be directed to the existing stormwater infrastructure without restriction and will be compensated for in areas with attenuation.

Runoff for area B2 will flow overland towards the proposed catch basin systems. Stormwater will be restricted by a Tempest LMF85 ICD (or equivalent product) to a maximum release rate of *10.59 L/s*. The catch basin system will provide *73.2 m³* of surface storage.

Runoff from area B3 will be controlled and stored on the roof of the proposed building (B3) using 4 roof drains. Roof drains will be used to limit the flow from the roof to the specified allowable release rate. For calculation purposes a Watts Accutrol roof drain in the closed position was used to estimate a reasonable roof flow. Other products may be specified at detailed building design provided release rates and storage volumes are respected. As seen in *Table 8*, below, stormwater will be restricted to a maximum release rate of 1.26 L/s, allowing for a proposed 63.8 m³ of roof storage.

Table 8: Roof Drainage Summary

Drainage Area	Area (ha)	# of Roof Drains	Storage Depth (mm)		Flow Per Roof Drain (L/s)		Total Flow Rate (L/s)	
			5-Year	100-Year	5-Year	100-Year	5-Year	100-Year
B3	0.09	4	45	90	0.32	0.32	1.26	1.26

7.5 Quality Control

As noted in *Section 7.1*, quality controls are required for the development. Per drawing *C102*, an oil & grit separator is proposed to be installed at the downstream end of the proposed storm servicing. The oil & grit separator structure will provide an enhanced level of treatment (80% TSS removal) for the parking lot and landscapes areas (B2) and the rooftop (B3).

Storm runoff from area B1 will maintain existing drainage patterns. Runoff collected from area B1 will continue to flow overland towards the existing storm sewer system at 2920 Sheffield Road, where it will be treated for quality by an existing Stormceptor unit.

8.0 EROSION AND SEDIMENT CONTROL

8.1 Temporary Measures

Before construction begins, temporary silt fence, straw bale or rock flow check dams will be installed at all-natural runoff outlets from the property. It is crucial that these controls be maintained throughout construction and inspection of sediment and erosion control will be facilitated by the Contractor or Contract Administration staff throughout the construction period.

Silt fences will be installed where shown on the final engineering plans, specifically along the downstream property limits. The Contractor, at their discretion or at the instruction of the City, Conservation Authority or the Contract Administrator shall increase the quantity of sediment and erosion controls on-site to ensure that the site is operating as intended and no additional sediment finds its way off site. The rock flow, straw bale & silt fence check dams and barriers shall be inspected weekly and after rainfall events. Care shall be taken to properly remove sediment from the fences and check dams as required. Fibre roll barriers are to be installed at all existing curb inlet catch basins and filter fabric is to be placed under the grates of all existing catch basins and manholes along the frontage of the site and any new structures immediately upon installation. The measures for the existing/proposed structures are to be removed only after all areas have been paved. Care shall be taken at the removal stage to ensure that any silt that has accumulated is properly handled and disposed of. Removal of silt fences without prior removal of the sediments shall not be permitted.

Although not anticipated, work through winter months shall be closely monitored for erosion along sloped areas. Should erosion be noted, the Contractor shall be alerted and shall take all necessary steps to rectify the situation. Should the Contractor's efforts fail at remediating the eroded areas, the Contractor shall contact the City and/or Conservation Authority to review the site conditions and determine the appropriate course of action. As the ground begins to thaw, the Contractor shall place silt fencing at all required locations as soon as ground conditions warrant. Please see the *Site Grading, Drainage and Sediment & Erosion Control Plan* for additional details regarding the temporary measures to be installed and their appropriate OPSD references.

8.2 Permanent Measures

It is expected that the Contractor will promptly ensure that all disturbed areas receive topsoil and seed/sod and that grass be established as soon as possible. Any areas of excess fill shall be removed or levelled as soon as possible and must be located a sufficient distance from any watercourse to ensure that no sediment is washed out into the watercourse. As the vegetation growth within the site provides a key component to the control of sediment for the site, it must be properly maintained once established. Once the construction is complete, it will be up to the landowner to maintain the vegetation and ensure that the vegetation is not overgrown or impeded by foreign objects.

9.0 SUMMARY

- A new 945 m^2 building is proposed to be constructed west of the existing building at 2920 Sheffield Road. The development is proposed within 0.35 ha of the site.
- It is proposed to service the new building through the existing service connection for water and sanitary. A new storm service is proposed to collect and control drainage within the development area.
- It is proposed to service the development area via a series of a series of catch basin storage and roof storage. The storm system will connect to the existing 1500 mm diameter concrete storm sewer located south of the site.
- Storage for the 5- through 100-year storm events will be provided by catch basin storage and rooftop storage.
- Quality controls will be provided up to an enhanced level of treatment via an Oil and Grit separator.

10.0 RECOMMENDATION

Based on the information presented in this report, we recommend that City of Ottawa approve this Servicing and Stormwater Management report in support of the proposed development at 2920 Sheffield Road.

This report is respectfully being submitted for approval.

Regards,

McIntosh Perry Consulting Engineers Ltd.



Alison J. Gosling, P.Eng.
Project Engineer, Land Development
T: 613.714.4629
E: a.gosling@mcintoshperry.com

Francis J. Valenti, EIT.
Engineering Intern, Land Development
T: 613.808.2123
E: f.valenti@mcintoshperry.com

11.0 STATEMENT OF LIMITATIONS

This report was produced for the exclusive use of Ross & Anglin LTD. The purpose of the report is to assess the existing stormwater management system and provide recommendations and designs for the post-construction scenario that are in compliance with the guidelines and standards from the Ministry of the Environment, Parks and Climate Change, City of Ottawa and local approval agencies. McIntosh Perry reviewed the site information and background documents listed in Section 2.0 of this report. While the previous data was reviewed by McIntosh Perry and site visits were performed, no field verification/measures of any information were conducted.

Any use of this review by a third party, or any reliance on decisions made based on it, without a reliance report is the responsibility of such third parties. McIntosh Perry accepts no responsibility for damages, if any, suffered by any third party as a result of decisions or actions made based on this review.

The findings, conclusions and/or recommendations of this report are only valid as of the date of this report. No assurance is made regarding any changes in conditions subsequent to this date. If additional information is discovered or becomes available at a future date, McIntosh Perry should be requested to re-evaluate the conclusions presented in this report, and provide amendments, if required.

**APPENDIX A
KEY PLAN**

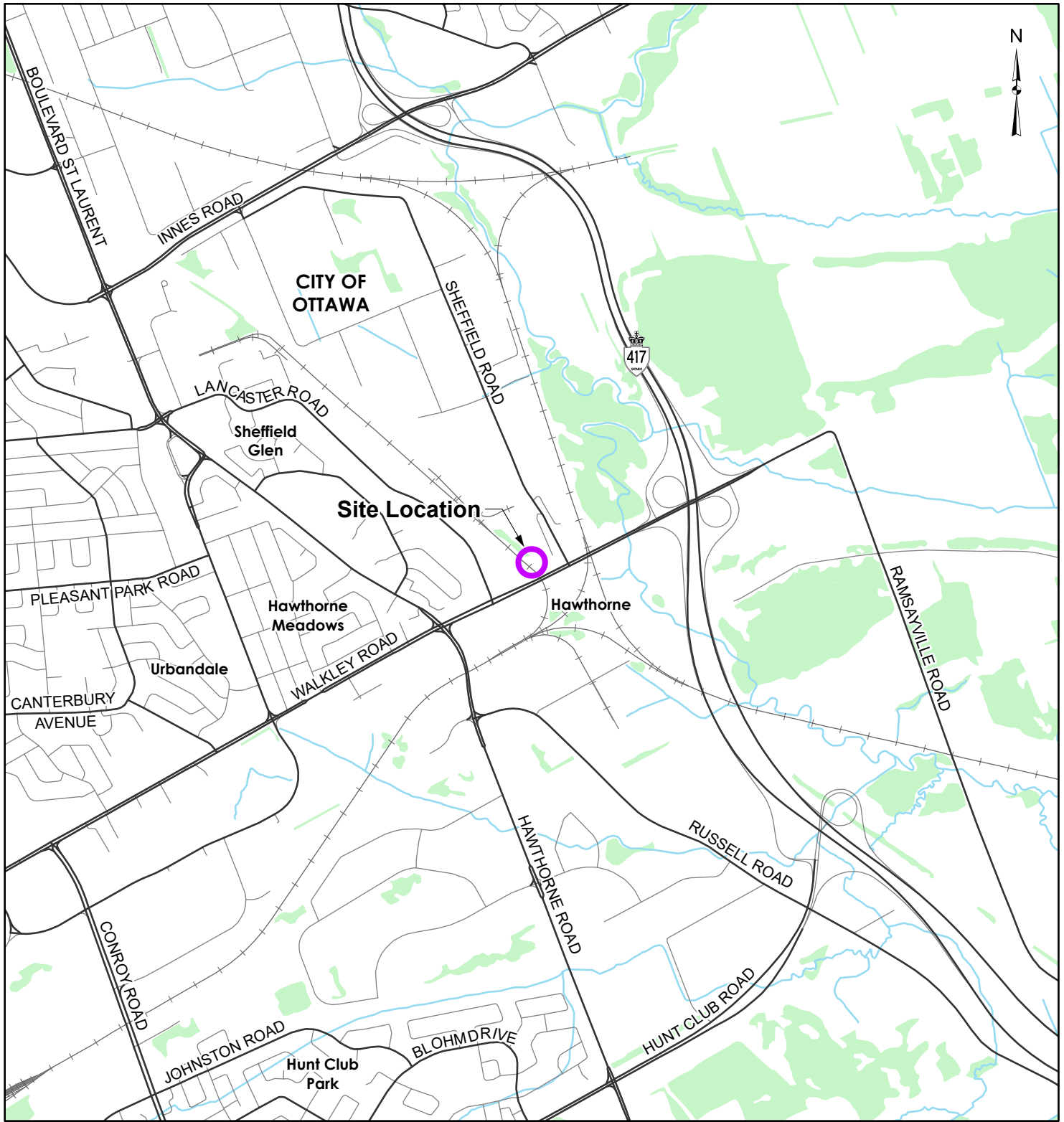

LEGEND

- Site Location
- Local Road
- Major Road
- Railroad
- Watercourse
- Wooded Area

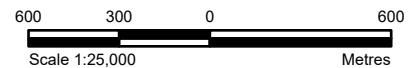

REFERENCE

GIS data provided by the Ontario Ministry of Northern Development, Mines, Natural Resources and Forestry, 2022.

CLIENT:	ROSS & ANGLIN LTD		
PROJECT:	2920 SHEFFIELD ROAD, OTTAWA, ON		
TITLE:	SITE LOCATION		
McINTOSH PERRY	PROJECT NO: CCO-22-0160	FIGURE:	
Date	Jan., 28, 2022	1	
GIS	EU		
Checked By	FV		

C:\Users\uncum\OneDrive\GIS - Documents\Projects\2022\CCO\CCO-22-0160\Ross and Anglin Ltd - Civil - 2020 Sheffield.aprx\Key Maps\LandDevelopment\CCO-22-0160 - OptionD - Site Location.aprx

**APPENDIX B
BACKGROUND DOCUMENTS**

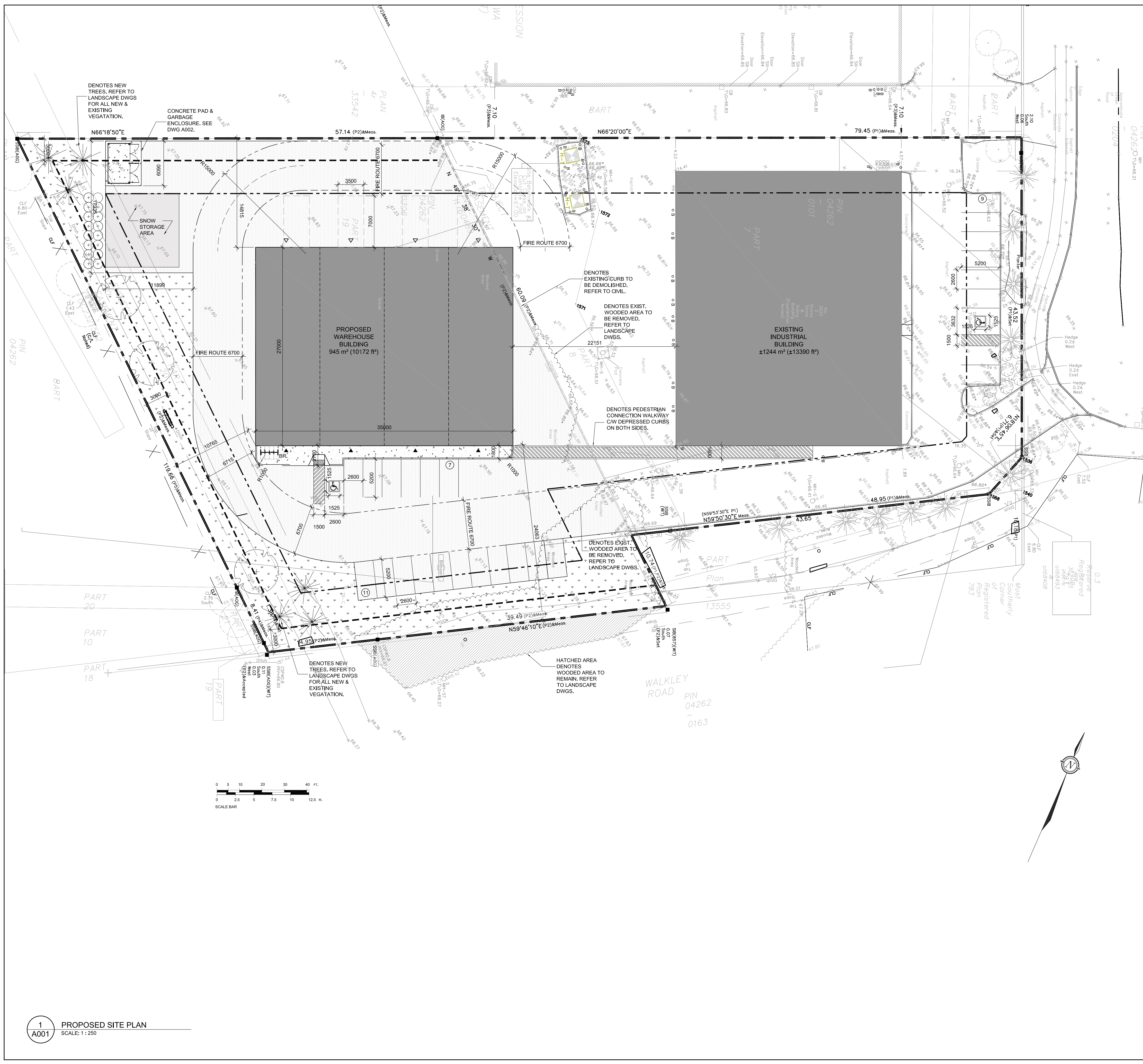

LEGEND

- PROPERTY BOUNDARY LINE.
- SET BACK LINE
- LANDSCAPE BUFFER
- FIRE ROUT LINES
- PROPOSED & EXISTING BUILDING
- ASPHALT (REFER TO CIVIL)
- CONCRETE SURFACE. REFER TO CIVIL DWGS.
- LANDSCAPED AREA
- DENOTES PAINTED PEDESTRIAN WALKWAYS
- ENTRANCE LOCATIONS.
- OH DOOR LOCATIONS
- CONCRETE CURB RAMP C/W TWSI
- BR. BICYCLE RACK (4 SPACES)

GENERAL NOTES:

- REFER TO "TOPOGRAPHIC PLAN OF SURVEY OF" PART OF LOT 24, CONCESSION 3 (OTTAWA FRONT), GEOGRAPHIC TOWNSHIP OF GLOUCESTER, CITY OF OTTAWA, SURVEYED BY ANNIS, OSULLIVAN, VOLLEBEK LTD. ONTARIO LAND SURVEYORS.

SITE DATA:

BUILDING AREA: NEW WAREHOUSE (1 STOREY) 945m²

GROSS FLOOR AREA: (City of Ottawa Zoning Bylaw) Gross floor area means the total area of each floor whether located above, at or below grade, measured from the interiors of outside walls and including floor area occupied by interior walls and floor area created by bay windows, but excluding:

- floor area occupied by shared mechanical, service and electrical equipment that serve the building; (By-law 2008-326)
- common hallways, corridors, stairwells, elevator shafts and other voids; steps and landings; (By-law 2008-326)
- bicycle parking; motor vehicle parking or loading facilities;
- common laundry, storage and washroom facilities that serve the building or tenants;
- common storage areas that are accessory to the principal use of the building; (By-law 2008-326)
- common amenity area and play areas accessory to a principle use on the lot; and (By-law 2008-326)
- living quarters for a caretaker of the building.

EXISTING MULTI TENANTS INDUSTRIAL NEW WAREHOUSE (1 STOREY): 945m²
 TOTAL: 2091m²

GROSS AREA: (Ontario Building Code definition) The total area of all floors above grade measured between the outside surfaces of exterior walls or between the outside surfaces of exterior walls and the centre line of firewalls, except that, in any occupancy other than a residential occupancy, where an access or a building service penetrates a firewall, measurements shall not be taken to the centre line of such firewall.

EXISTING MULTI TENANTS INDUSTRIAL NEW WAREHOUSE (1 STOREY): 1244m²
 TOTAL: 2189m²

ZONING:

1.0 ZONING DESIGNATIONS (Part 11):
 IH - HEAVY INDUSTRIAL ZONE

2.0 ZONING PROVISIONS:
 TABLE 201 - IH ZONE PROVISIONS:

	REQUIRED	PROVIDED
MINIMUM LOT WIDTH (m):	NO MIN.	43.52
MINIMUM LOT AREA (m ²):	4000	7,226
MINIMUM FRONT YARD SETBACK (m):	7.5	11.075
MINIMUM REAR YARD SETBACK (m):	7.5	10.759
MINIMUM INTERIOR SIDE YARD SETBACK (m):	7.5	14.832
MINIMUM CORNER SIDE YARD SETBACK (m):	7.5	24.047
MAXIMUM PRINCIPAL BUILDING HEIGHT (m):	22	7.12
MAXIMUM FLOOR SPACE INDEX	2	
MINIMUM WIDTH OF LANDSCAPING (m):	3	3

3.0 PARKING (Section 101):

Minimum Required:

INDUSTRIAL WAREHOUSE: 18 (0.8/100m² of GFA)
 TOTAL: 18

Existing provided:

STANDARD SPACE: 8
 BARRIER-FREE: 1
 TOTAL: 9

New Provided:

STANDARD SPACE: 17
 BARRIER-FREE: 1
 TOTAL: 18

TOTAL PROVIDED: 18

4.0 BICYCLE PARKING (Section 111):

Minimum Required:

INDUSTRIAL WAREHOUSE: 2 (1/1500m² of GFA)
 TOTAL: 2

Provided:

STANDARD SPACE: 4
 TOTAL: 4

5.0 LOADING (Section 113):

Minimum Required:

INDUSTRIAL WAREHOUSE: 1 (2000-4999m² of GFA)
 TOTAL: 1

Provided:

STANDARD SPACE (3.5m W X 7m L): (EXISTING) 4 + (NEW) 4
 TOTAL: 8

6.0 ACCESSIBLE PARKING PROVISION REQUIREMENTS
 (Parking Bylaw 2017-301, PART C Section 111):

Minimum Required:

1 TYPE A PARKING SPACE
 1 TYPE B PARKING SPACE

Provided:

1 TYPE A PARKING SPACE
 1 TYPE B PARKING SPACE

CLIENT

PROJECT NORTH

ISSUE	DESCRIPTION	DATE
03	ISSUED FOR SITE PLAN CONTROL	17/02/2022
02	ISSUED FOR COORDINATION/CLIENT REVIEW	28/09/2021
01	ISSUED FOR COORDINATION/CLIENT REVIEW	12/08/2021

IT IS THE RESPONSIBILITY OF THE APPROPRIATE CONTRACTOR TO CHECK AND VERIFY ALL DIMENSIONS ON SITE AND PROMPTLY REPORT ALL ERRORS AND/OR OMISSIONS TO THE CONSULTANT BEFORE WORK COMMENCES.

ALL WORK IS TO FOLLOW THE OBC 2012 AND ANY OTHER APPLICABLE CODES AND REGULATIONS.

DO NOT SCALE DRAWINGS.

PROFESSIONAL STAMP

PROJECT

2920 SHEFFIELD DEVELOPMENT OTTAWA, ON

DRAWING

PROPOSED SITE PLAN

PROJECT No:	033	REVISION:	02
DRAWN:	SL	DATE:	AUGUST 2021
APPROVED:	ES	SCALE:	AS SHOWN
DRAWING No:	A001		

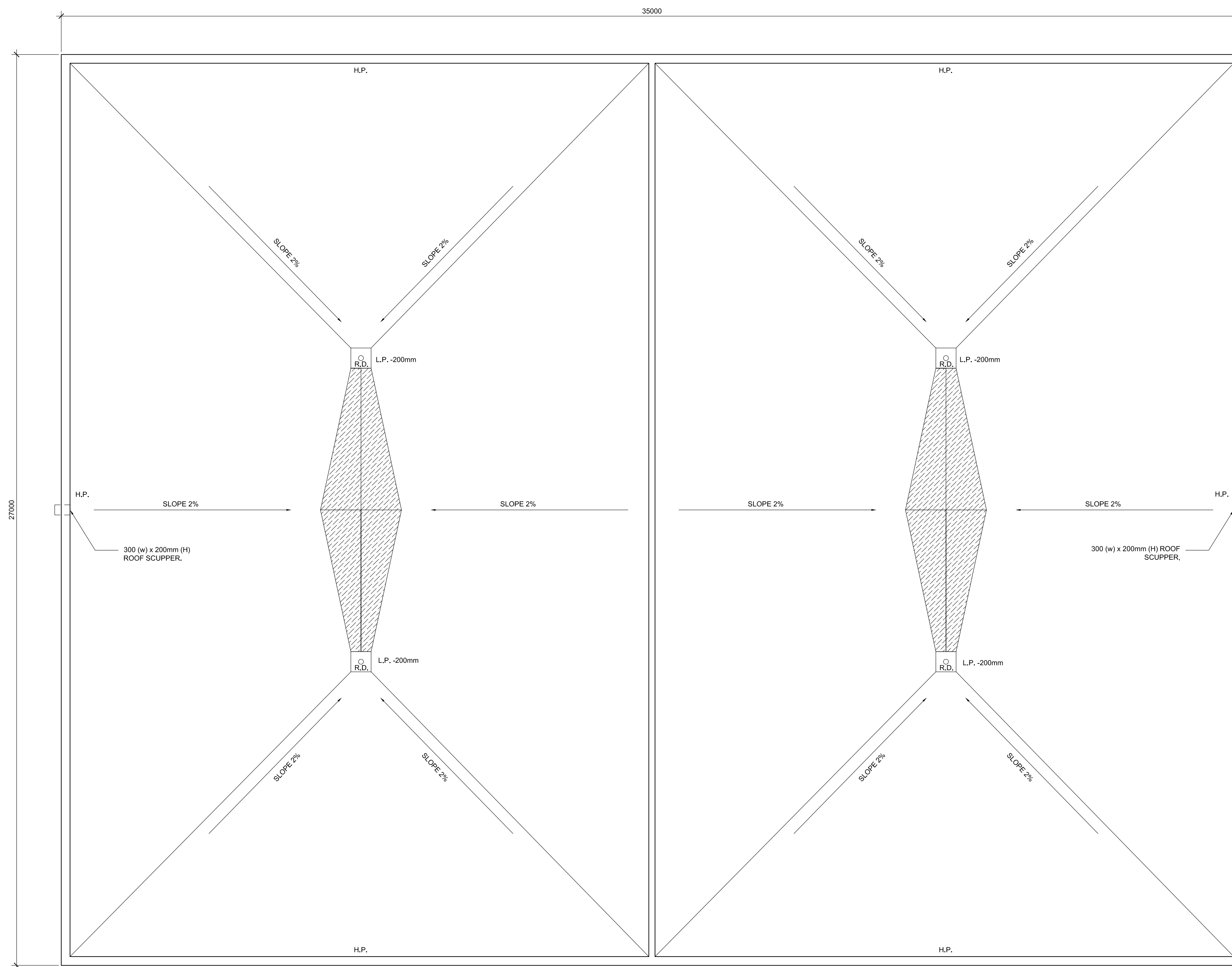

1 ROOF PLAN:
A203 SCALE: 1:75

CLIENT

PROJECT NORTH

ISSUE	DESCRIPTION	DATE
01	ISSUED FOR SITE PLAN CONTROL REVISIONS	19/09/2022

IT IS THE RESPONSIBILITY OF THE APPROPRIATE CONTRACTOR TO CHECK AND VERIFY ALL DIMENSIONS ON SITE AND PROMPTLY REPORT ALL ERRORS AND/OR OMISSIONS TO THE CONSULTANT BEFORE WORK COMMENCES.

ALL WORK IS TO FOLLOW THE OBC 2012 AND ANY OTHER APPLICABLE CODES AND REGULATIONS.

DO NOT SCALE DRAWINGS.

PROFESSIONAL STAMP

PROJECT

2920 SHEFFIELD
DEVELOPMENT
OTTAWA, ON

DRAWING

ROOF PLAN

PROJECT No:	033	REVISION:	00
DRAWING:	SL	DATE:	SEPTEMBER 2022
APPROVED:	ES	SCALE:	AS SHOWN

DRAWING No: **A203**

Francis Valenti

From: eric@es-arch.net
Sent: September 15, 2021 11:43 AM
To: 'Glenn Kavanagh'; Curtis Melanson; 'Rod Price'
Cc: 'Steve Lajeunesse'
Subject: FW: Pre-Application Consultation Follow-Up - 2920 Sheffield Road
Attachments: 2920 Sheffield - Pre-con Engineering Notes.pdf; 2920 Sheffield Option A (2).pdf; design_brief_submission requirements_2920 Sheffield.pdf; 210902_2920 Sheffield_PFP pre-app consult comments.pdf; Roof_Drain_Letter_Template.docx

Follow Up Flag: Follow up
Flag Status: Completed

Glenn and Team,

Fresh off the press are the Pre-Consultant comments and requirements as we prepare for an SPA submission. The next step is for Steve and I to update the site plan to suit and then layer in the Civil and Landscaping drawings.

Rod –

Once you have had a chance to review, please let us know if the City is off-side on anything they are asking.

Eric Schlange, Architect
B.A.S, M.Arch, OAA

es ARCHITECT
e: eric@es-arch.net
p: 613.203.3760

From: Ezzio, Sarah <sarah.ezzio@ottawa.ca>
Sent: September 15, 2021 11:37 AM
To: Rod Price <rortar9@gmail.com>
Cc: Harrold, Eric <eric.harrold@ottawa.ca>; van Wyk, Adrian <adrian.vanwyk@ottawa.ca>; Gervais, Josiane <josiane.gervais@ottawa.ca>; eric@es-arch.net
Subject: Pre-Application Consultation Follow-Up - 2920 Sheffield Road

Good morning Rod,

Please refer to the below notes regarding the Pre-Application Consultation Meeting held on September 2, 2021 for the site at 2920 Sheffield Road.

Project:

During the meeting, a proposal to develop a new, 945 square-metre warehouse building and the associated surface parking was discussed. The new warehouse is proposed to be located on the rear portion of the site, within the former rail corridor, and the existing warehouse building will be retained.

Below are staff's preliminary comments:

Policies/Designations of the site

- Official Plan – designated Urban Employment Area
- Zoning – Heavy Industrial, IH
 - Within Area C for Minimum Parking Requirements (Schedule 1A)

Engineering

- Please find the engineering pre-consult notes attached to this email.

Planning

- Minimize surface parking on the south side of the building.
- Overall, given the site's location to the 401 on ramp, this site offers an opportunity for intensification of warehouse uses.
- Include the parking calculations for both the existing and the proposed warehouse as well as the GFA of the existing building on the site plan.
- Please increase pedestrian connections. There is a walkway out front of existing building and a walkway along Sheffield, please integrate the sidewalks with the newly proposed sidewalk to improve the pedestrian experience. The accessibility of the site may also be improved by moving the pedestrian entrance to the front of the rear warehouse building.
- The minimum width of landscaped buffer per the ZBL is 3m, but please retain and provide landscape elements wherever possible.
- Please ensure the following items are shown on the site plan:
 - Snow storage areas,
 - Garbage enclosure details
 - Bicycle parking dimensions
 - Parking and loading space dimensions
 - Differentiate between existing/future features. Site Plan must show entire site.
- If there is an easement, we will be asking for verification from easement holder that proposed site works are permitted.
- Include accessible parking spaces per Ottawa's Accessibility Design Standards.
- Bicycle parking is required on the site at rates established by Section 111 – 1 per 1,500 m GFA
- Overhead hydro wires on the south of the site, consult with Hydro Ottawa that site works are acceptable.
- ESA is required.
- Consult with ward councilor, Jean Cloutier, and applicable community associations before application submission.

Urban Design

1. Please see the attached Design Brief Submission Requirements. A scoped Design Brief will be required, which may be combined with a Planning Rationale.
2. Landscaping
 - It is recommended that hard surfaces be kept to a minimum, except where required for parking, storage, or vehicle circulation.
 - A soft landscaped buffer is recommended along the rear and side lot lines.
 - It is recommended that new shrubs/trees be introduced along the south lot line to provide visual screening from Walkley Road.
3. Pedestrian and bicycle circulation
 - It is recommended that pedestrian circulation be carefully considered, and options explored to provide a connection between the proposed building and Sheffield Road.
 - It is recommended that bicycle parking be provided.
4. Sustainability
 - It is recommended that the applicant consider introducing sustainable design features, such as light coloured materials, swales, etc.

- Should you have any questions on the Urban Design comments, please contact Adrian van Wyk at Adrian.vanwyk@ottawa.ca

Transportation

- Follow Transportation Impact Assessment Guidelines
 - Submit a Screening form at your earliest convenience. A full Transportation Impact Assessment will be required if any of the triggers on the screening form are satisfied.
 - Start this process asap. The application will not be deemed complete until the submission of the draft step 1-4, including the functional draft RMA package (if applicable) and/or monitoring report (if applicable).
- Consider including a dedicated pedestrian path from the proposed site main entrance to the sidewalk along Sheffield.
- On site plan:
 - Show all details of the roads abutting the site up to and including the opposite curb; include such items as pavement markings, accesses and/or sidewalks.
 - Turning movement diagrams required for all accesses showing the largest vehicle to access/egress the site.
 - Turning movement diagrams required for internal movements (loading areas, garbage).
 - Show all curb radii measurements; ensure that all curb radii are reduced as much as possible.
 - Show dimensions for site elements (i.e. lane/aisle widths, access width and throat length, parking stalls, sidewalks, pedestrian pathways, etc.)
 - Clearly show loading areas and their dimensions.
 - Ensure all crosswalks located internally on the site provide a TWSI at the depressed curb, per requirements of the Integrated Accessibility Standards Regulation under the AODA.
 - Grey out any area that will not be impacted by this application.
- As the proposed site is commercial/institutional/industrial and for general public use, AODA legislation applies. Ensure the site conforms to these requirements. Consider using the City's Accessibility Design Standards.
- Should you have any follow-up questions on the Transportation comments, please feel free to contact Josiane Gervais at Josiane.Gervais@ottawa.ca

Rideau Valley Conservation Authority

- The proposed development must provide enhanced water quality protection (80% TSS Removal) as part of the development. Best management practices to maximize on-site water quality protection is encouraged where possible.
- There are no identified natural hazards, and the site is not regulated by the conservation authority (therefore no permits are required from our office).

Parks & Facilities Planning

- Please see parks and facilities planning comments attached.

Forestry & Trees

1. a Tree Conservation Report (TCR) must be supplied for review along with the suite of other plans/reports required by the City
 - a. an approved TCR is a requirement of Site Plan approval.
 - b. The TCR may be combined with the LP provided all information is supplied.
2. As of January 1 2021, any removal of privately-owned trees 10cm or larger in diameter, or publicly (City) owned trees of any diameter requires a tree permit issued under the Tree Protection Bylaw (Bylaw 2020 – 340); the permit will be based on an approved TCR and made available at or near plan approval.
3. The Planning Forester from Planning and Growth Management as well as foresters from Forestry Services will review the submitted TCR
 - a. If tree removal is required, both municipal and privately-owned trees will be addressed in a single permit issued through the Planning Forester

- b. Compensation may be required for city owned trees – if so, it will need to be paid prior to the release of the tree permit
4. the TCR must list all trees on site by species, diameter and health condition
5. please identify trees by ownership – private onsite, private on adjoining site, city owned, co-owned (trees on a property line)
6. the TCR must list all trees on adjacent sites if they have a critical root zone that extends onto the development site
7. If trees are to be removed, the TCR must clearly show where they are, and document the reason they cannot be retained
8. All retained trees must be shown and all retained trees within the area impacted by the development process must be protected as per City guidelines available at Tree Protection Specification or by searching Ottawa.ca
 - a. the location of tree protection fencing must be shown on a plan
 - b. show the critical root zone of the retained trees
 - c. if excavation will occur within the critical root zone, please show the limits of excavation
9. the City encourages the retention of healthy trees; if possible, please seek opportunities for retention of trees that will contribute to the design/function of the site.
10. For more information on the process or help with tree retention options, contact Mark Richardson mark.richardson@ottawa.ca or on City of Ottawa

LP tree planting requirements:

- For additional information on the following please contact tracy.smith@Ottawa.ca
- Minimum Setbacks
 - Maintain 1.5m from sidewalk or MUP/cycle track.
 - Maintain 2.5m from curb
 - Coniferous species require a minimum 4.5m setback from curb, sidewalk or MUP/cycle track/pathway.
 - Maintain 7.5m between large growing trees, and 4m between small growing trees. Park or open space planting should consider 10m spacing.
 - Adhere to Ottawa Hydro’s planting guidelines (species and setbacks) when planting around overhead primary conductors.
- Tree specifications
 - Minimum stock size: 50mm tree caliper for deciduous, 200cm height for coniferous.
 - Maximize the use of large deciduous species wherever possible to maximize future canopy coverage
 - Tree planting on city property shall be in accordance with the City of Ottawa’s Tree Planting Specification; and include watering and warranty as described in the specification (can be provided by Forestry Services).
 - Plant native trees whenever possible
 - No root barriers, dead-man anchor systems, or planters are permitted.
 - No tree stakes unless necessary (and only 1 on the prevailing winds side of the tree)
- Hard surface planting
 - Curb style planter is highly recommended
 - No grates are to be used and if guards are required, City of Ottawa standard (which can be provided) shall be used.
 - Trees are to be planted at grade
- Soil Volume
 - Please ensure adequate soil volumes are met:

Tree Type/Size	Single Tree Soil Volume (m3)	Multiple Tree Soil Volume (m3/tree)
Ornamental	15	9
Columnar	15	9
Small	20	12
Medium	25	15

Large	30	18
Conifer	25	15

Please note that these soil volumes are not applicable in cases with Sensitive Marine Clay.

- Sensitive Marine Clay
 - Please follow the City's 2017 Tree Planting in Sensitive Marine Clay guidelines

This proposal is subject to **Site Plan Control application** (Standard, Staff Approval). The required Plans & Study List is below. Please refer to the City's Site Plan Control By-Law to determine whether a site plan control application is required.

Required Plans and Studies:

- Geotechnical Investigation Report
- Stormwater Management and Site Servicing Report
- Site Servicing Plan
- Grading Plan
- Erosion and Sediment Control Plan
- Storm Drainage / Ponding Plan
- Roof Drain Control Letter (if rooftop storage is proposed). Template attached.
- ECA (if applicable)
- Site Plan
- Planning Cover Letter
- Landscape Plan
- TCR (Landscape Plan and TCR can be combined)
- Design Brief
- Plan of Survey
- Site Lighting Plan and letter will be required as condition of approval
- Building Elevations
- Phase I ESA
- Design Brief

Please refer to the links to "[Guide to preparing studies and plans](#)" and [fees](#) for general information. Additional information is available related to [building permits](#), [development charges](#), and the [Accessibility Design Standards](#). Be aware that other fees and permits may be required, outside of the development review process. You may obtain background drawings by contacting informationcentre@ottawa.ca.

These pre-con comments are valid for one year. If you submit a development application(s) after this time, you may be required to meet for another pre-consultation meeting and/or the submission requirements may change. You are as well encouraged to contact us for a follow-up meeting if the plan/concept will be further refined.

We are happy to discuss further or answer any follow-up questions.

All the best,

Sarah Ezzio

Planner I | Urbaniste I

Development Review (South Services) | Examen des projets d'aménagement (services sud)

Planning, Infrastructure and Economic Development | Services de planification, d'infrastructure et de développement économique

City of Ottawa | Ville d'Ottawa

 613.580.2400 ext./poste 23493

ottawa.ca/planning / ottawa.ca/urbanisme

Sarah Ezzio

Planner I | Urbaniste I

Development Review (South Services) | Examen des projets d'aménagement (services sud)

Planning, Infrastructure and Economic Development | Services de planification, d'infrastructure et de développement économique

City of Ottawa | Ville d'Ottawa

 613.580.2424 ext./poste 23493

ottawa.ca/planning / ottawa.ca/urbanisme

This e-mail originates from the City of Ottawa e-mail system. Any distribution, use or copying of this e-mail or the information it contains by other than the intended recipient(s) is unauthorized. Thank you.

Le présent courriel a été expédié par le système de courriels de la Ville d'Ottawa. Toute distribution, utilisation ou reproduction du courriel ou des renseignements qui s'y trouvent par une personne autre que son destinataire prévu est interdite. Je vous remercie de votre collaboration.

MEMO

Date: September 2, 2021

To /
Destinataire **Sarah Ezzio, Planner**

From /
Expéditeur **Eric Harrold, Project Manager, Infrastructure Approvals**

Subject /
Objet **Pre-Application Consultation
2920 Sheffield Road, Ward 18
Warehouse**

File No. PC2021-0306

The following are the engineering comments pertaining to the Pre-Consultation meeting for 2920 Sheffield (Site Plan Application) which was held on September 2nd.

List of Reports and Plans (Site Plan Control):

1. Site Servicing Plan
2. Grading Plan
3. Erosion and Sediment Control Plan
4. Storm Drainage / Ponding Plan
5. Stormwater Management and Site Servicing Report
6. Geotechnical Investigation Report
7. Roof Drain Control Letter (if rooftop storage is proposed)
8. ECA (if applicable)

Please note the following information regarding the engineering design submissions for the above noted site:

1. The Servicing Study Guidelines for Development Applications are available at the following address:
<https://ottawa.ca/en/city-hall/planning-and-development/how-develop-property/development-application-review-process-2/guide-preparing-studies-and-plans>
2. Servicing and site works shall be in accordance with the following documents:
 - Ottawa Sewer Design Guidelines (October 2012) and all the Technical Bulletins including, Technical Bulletin PIEDTB-2016-01 and ISTB-2018-01
 - Ottawa Design Guidelines – Water Distribution (2010) and Technical Bulletins ISD-2010-2, ISDTB-2014-02 and ISTB-2018-02
 - Geotechnical Investigation and Reporting Guidelines for Development Applications in the City of Ottawa (2007)
 - City of Ottawa Slope Stability Guidelines for Development Applications (revised 2012)
 - City of Ottawa Environmental Noise Control Guidelines (January, 2016)
 - City of Ottawa Park and Pathway Development Manual (2012)
 - City of Ottawa Accessibility Design Standards (2012)

- Ottawa Standard Tender Documents (latest version)
 - Ontario Provincial Standards for Roads & Public Works (2013)
3. Record drawings and utility plans are also available for purchase from the City (Contact the City's Information Centre by email at InformationCentre@ottawa.ca or by phone at (613) 580-2424 x 44455
4. The Stormwater Management Criteria, for the subject site, is to be based on the following:
- The 2-yr storm or 5-yr storm event using the IDF information derived from the Meteorological Services of Canada rainfall data, taken from the MacDonald Cartier Airport, collected 1966 to 1997.
 - For separated sewer system built pre-1970 the design of the storm sewers are based on a 2 year storm.
 - The pre-development runoff coefficient or a maximum equivalent 'C' of 0.5, whichever is less (§ 8.3.7.3).
 - A calculated time of concentration (Cannot be less than 10 minutes).
 - Flows to the storm sewer in excess of the 5-year storm release rate, up to and including the 100-year storm event, must be detained on site.
 - There may be area specific SWM Criteria within SWM &/or Sub-watershed studies that may apply, please check.
 - Quality control requirements to be provided by Rideau Valley Conservation Authority (RVCA).
 - **Please note that it is generally only acceptable to have one service connection per lot. It is preferred that the existing services for 2920 Sheffield are re-used (and/or upgraded as necessary) for the proposed warehouse. Please submit a conceptual servicing plan to the City's project manager so that the proposed servicing arrangement can be reviewed.**

5. Deep Services:

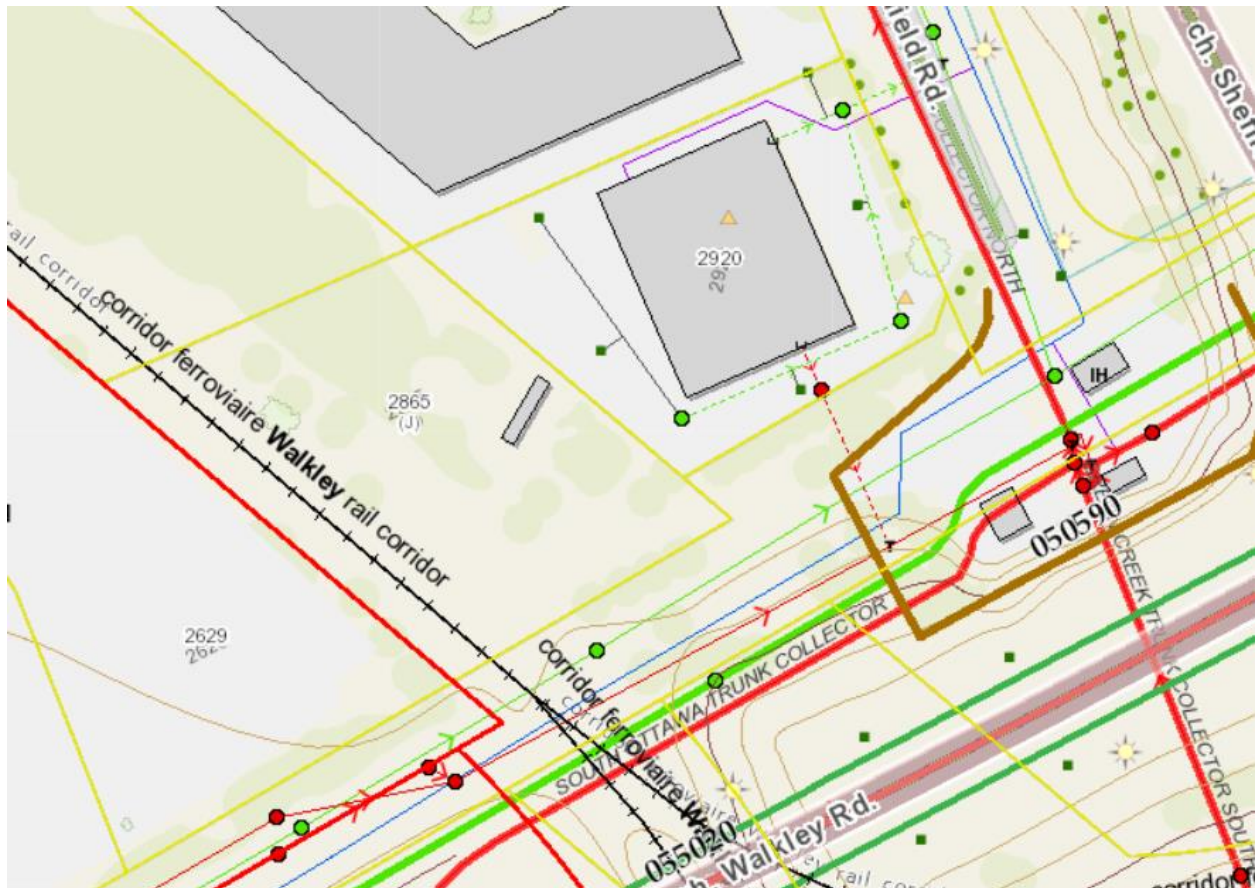

i. A plan view of the approximate services may be seen above. Services should ideally be grouped in a common trench to minimize the number of road cuts. The sizing of available future services is:

a. Connections (Sheffield Road):

i. Existing 1200 mm dia. STM (Conc.)

- ii. Existing 305 mm dia. Watermain (CI)
- b. Connections (Walkley Road)
 - i. Existing 1500 mm dia. STM (Conc.)
 - ii. Existing 305 mm dia. Watermain (DI)
 - iii. Existing 675 mm dia. SAN (Conc.)
- ii. *Provide existing servicing information and the recommended location for the proposed connections. Services should ideally be grouped in a common trench to minimize the number of road cuts.*
- iii. *Provide information on the monitoring manhole requirements – should be located in an accessible location on private property near the property line (ie. Not in a parking area).*
- iv. *Provide information on the type of connection permitted*

Sewer connections to be made above the springline of the sewermain as per:

- a. Std Dwg S11.1 for flexible main sewers – *connections made using approved tee or wye fittings.*
 - b. Std Dwg S11 (For rigid main sewers) – *lateral must be less than 50% the diameter of the sewermain,*
 - c. Std Dwg S11.2 (for rigid main sewers using bell end insert method) – *for larger diameter laterals where manufactured inserts are not available; lateral must be less than 50% the diameter of the sewermain,*
 - d. Connections to manholes permitted when the connection is to rigid main sewers where the lateral exceeds 50% the diameter of the sewermain. – Connect obvert to obvert with the outlet pipe unless pipes are a similar size.
 - e. *No submerged outlet connections.*
6. Civil consultant must request boundary conditions from the City's assigned Project Manager prior to first submission. Water Boundary condition requests must include the location of the service and the expected loads required by the proposed development. Please provide the following information:
- i. Location of service(s)
 - ii. Type of development and the amount of fire flow required (as per FUS, 1999).
 - iii. Average daily demand: ___ l/s.
 - iv. Maximum daily demand: ___ l/s.
 - v. Maximum hourly daily demand: ___ l/s.

- vi. Hydrant location and spacing to meet City's Water Design guidelines.
 - vii. Water supply redundancy will be required for more than 50 m³/day water demand. Provide watermain looped connection or with isolation valve to meet this requirement. Based on the proposed scope of the project, it is unlikely that this criteria will be exceeded.
7. Phase 1 Environmental Site Assessment (ESA) and Phase 2 ESAs must conform to clause 4.8.4 of the Official Plan that requires that development applications conform to Ontario Regulation 153/04. The ESA may provide recommendations where site contamination may be present. The recommendations from the ESA need to be coordinated with the servicing report to ensure compliance with the Sewer Use By-Law.
 8. MECP ECA Requirements – All development applications should be considered for an Environmental Compliance Approval (ECA) by the Ministry of the Environment, Conservation, and Parks (MECP);
 - a. The consultants determine if an approval for sewage works under Section 53 of OWRA is required and determines what type of application. The City's project manager may help confirm and coordinate with the MECP as required.
 - b. The project will be either transfer of review (standard), transfer of review (additional), direct submission, or exempt as per O. Reg. 525/98.
 - c. Pre-consultation is not required if applying for standard or additional works (Schedule A of the Agreement) under Transfer Review.
 - d. Pre-consultation with local District office of MECP is recommended for direct submission.
 - e. Consultant completes an MECP request form for a pre-consultation. Send request to moeccottawasewage@ontario.ca
 - f. ECA applications are required to be submitted online through the MECP portal. A business account required to submit ECA application. For more information visit <https://www.ontario.ca/page/environmental-compliance-approval>

NOTE: Site Plan Approval, or Draft Approval, is required before an application is sent to the MECP.
 9. Please contact RVCA for specific water quality requirements.
 10. General Engineering Submission requirements:
 - a. As per section 53 of the Professional Engineers Act, O. Reg 941/40, R.S.O. 1990, all documents prepared by engineers must be signed and dated on the seal.
 - b. All required plans are to be submitted on standard A1 size sheets (594mm x 841mm) sheets, utilizing a reasonable and appropriate metric scale as per City of Ottawa Servicing and Grading Plan Requirements: title blocks are to be placed on the right of the sheets and not along the bottom. Engineering plans may be combined, but the Site Plans must be provided separately. Plans shall include the survey monument used to confirm datum. Information shall be provided to enable a non-surveyor to locate the survey monument presented by the consultant.
 - c. All required plans & reports are to be provided in *.pdf format (at application submission and for any, and all, re-submissions)

Should you have any questions or require additional information, please contact me directly at (613) 580-2424, ext. 21447 or by email at eric.harrold@ottawa.ca.



CARLETON
PIN 15545-0000 (L7)
PART 5, PLAN 4R-7803

PART 6, PLAN 4R-7803

PART 4, PLAN 4R-7803

PART 2, PLAN 4R-7803

PART 3, PLAN 4R-7803

PART 1, PLAN 4R-7803

PART 7, PLAN 4R-7803

FINISHED FLOOR
ELEV. 66.85

PART 17,
PIN 04262-0225 (O1)
PLAN 5R-2313

PART 1, PLAN 5R-13555

PLAN 5R-13555

DEPTH AND ALIGNMENT OF EXISTING 150MM STORM AND ABANDONED 375mm SANITARY TO BE CONFIRMED IN THE FIELD PRIOR TO CONSTRUCTION. CONTRACTOR TO CHECK AND CONFIRM ANY PIPE CROSSING CONFLICTS WITH SANITARY CONNECTION.

SEE SANITARY SERVICE PROFILE DRAWING FOR ADDITIONAL INFORMATION

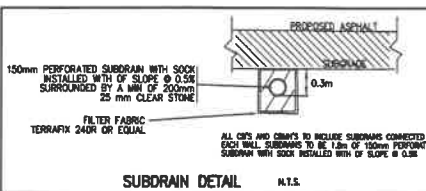

CATCHBASINS/CRIMANHOLES:
ALL C/S'S AND C/M'S TO INCLUDE SUBDRAINS CONNECTED AT EACH WALL. SUBDRAINS TO BE 1.8m OF 150mm PERFORATED SUBDRAIN WITH SOCK INSTALLED WITH SLOPE OF 0.5%

STATION	GRADE	TOP OF W/S (2.4m MIN COVER)
0+00	66.16	63.76
0+06	66.27	63.87
0+12	66.30	63.90
0+18	66.40	64.00
0+24	66.50	64.10
0+30	66.42	64.02
0+36	66.51	64.11
0+42	66.60	64.20
0+48	66.65	64.25
0+54	66.70	64.30
0+60	66.72	64.32

EROSION AND SILTATION CONTROL

- TOPSOIL TO BE DISPOSED OFF SITE.
- IF TOPSOIL IS LEFT ON SITE (e.g. STOCKPILED OR USED AS FILL) THEN THIS AREA MUST BE SEDED & SURROUNDED BY SILT FENCE.
- IF BUILDING CONSTRUCTION IS INTERRUPTED AND/OR INACTIVITY EXCEEDS 30 DAYS, STRIPPED/BAR AREAS WILL BE STABILIZED BY SEEDING.
- CONTRACTOR RESPONSIBLE FOR CONTROLLING MUD TRACKING AND SILT RUNOFF FROM SITE.
- EROSION AND SEDIMENT CONTROLS TO BE INSTALLED PRIOR TO START OF CONSTRUCTION AND MAINTAINED UNTIL SITE WORKS ARE COMPLETED AND STABILIZED.
- SILT FENCE AND SEDIMENT CONTROLS AT C/S'S AND M/F'S TO BE CHECKED AFTER STORMS AND CLEANED AS NECESSARY TO ENSURE EFFECTIVENESS.
- SEDIMENT TRAPS TO BE INSTALLED IN ALL C/S'S AND CLEANED AS NECESSARY TO ENSURE EFFECTIVENESS. OB SEDIMENT TRAPS TO BE REMOVED UPON COMPLETION OF BASE COURSE ASPHALT.
- CONTRACTOR RESPONSIBLE FOR CONTROLLING MUD TRACKING AND SILT RUNOFF FROM SITE.
- ALL SEDIMENT CONTROLS DEVICES MUST BE INSTALLED PRIOR TO COMMENCEMENT OF SITE GRADING WORKS. SEDIMENT CONTROLS MUST BE INSPECTED ON A REGULAR BASIS AND AFTER EVERY RAINFALL EVENT. REPAIRS MUST BE DONE IN A TIMELY MANNER TO PREVENT SEDIMENT FROM ENTERING THE WATER.

- SILT FENCE**
- SILT FENCE TO BE INSTALLED ALONG PERIMETER OF SITE.
 - SILTATION CONTROLS TO BE INSTALLED PRIOR TO THE START OF ANY WORK. SILT CONTROLS TO BE MAINTAINED UNTIL ALL WORK IS COMPLETED AND SITE IS STABILIZED.
 - SILT FENCE TO BE REINFORCED WITH STAIRED STRAIN BALES AS NECESSARY IN CONCENTRATED FLOW AREAS.

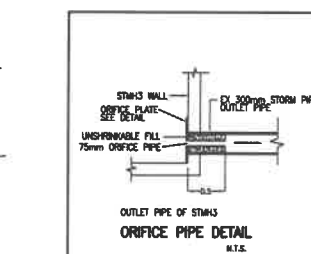
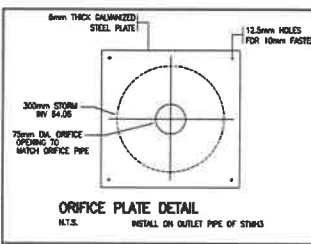

CONSTRUCTION NOTES:

- GENERAL**
 - SITE PLAN PROVIDED BY ARCHITECT
 - LEGAL SURVEY INFORMATION TAKEN FROM SITE PLAN
 - TOP SURVEY PROVIDED BY J.D. BARNES
 - ALL WORKS TO BE COMPLETED IN ACCORDANCE WITH THE LATEST CITY OF OTTAWA AND ONTARIO PROVINCIAL STANDARDS AND SPECIFICATIONS AND THE MINISTRY OF THE ENVIRONMENT AND ENERGY - LATEST EDITION.
 - THE CONTRACTOR IS RESPONSIBLE FOR LOCATING AND PROTECTING ALL EXISTING UTILITIES PRIOR TO AND DURING CONSTRUCTION.
 - THE SITE DIMENSIONS REFER TO ARCHITECTURAL SITE PLAN DRAWING.
 - FOR EXISTING SEALS INFORMATION REFER TO REPORTS.
 - CONTRACTOR RESPONSIBLE FOR OBTAINING ALL NECESSARY PERMITS PRIOR TO THE START OF CONSTRUCTION.
 - EXISTING ROAD AND SERVICES INFORMATION OBTAINED FROM TOPOGRAPHIC PLAN (BY OTHERS)
 - ALL RETAINING WALLS GREATER THAN 0.6m TO INCLUDE SAFETY DRAGS AS PER O.E.C.
- SEWERS**
 - BACKFILL & SEWER BEDDING AS OPSD 802.010, 802.013, 802.014
 - ALL BEDDING AND COVER MATERIAL TO BE GRANULAR 1/2" OR 19mm CRLS COMPACTED TO 95 PERCENT SPAWD.
 - CB LEADS TO BE ONE OF CONCRETE OR PVC THROUGHOUT.
 - STORM SEWER PIPE TO BE PVC SDR 35
 - SANITARY SEWER PIPE TO BE PVC SDR 26
- MANHOLES / CATCHBASINS**
 - STORM MANHOLES AS OPSD 701.010 WITH FRAME AND COVER AS OPSD 401.010 TYPE B.
 - ALL C/S'S AND C/M'S TO INCLUDE SUBDRAINS CONNECTED AT EACH WALL. SUBDRAINS TO BE 2.0m OF 150mm PERFORATED SUBDRAIN WITH SOCK INSTALLED WITH SLOPE OF 0.5%
 - PRECAST CATCHBASIN AS OPSD 705.005
 - WITH FRAME AND GRATE AS OPSD 400.02
 - STORM MANHOLE BEDDING TO BE TO COVER OF PIPE AS PER OPSD 701.010
 - SANITARY MANHOLE AS OPSD 701.010 WITH FRAME AND COVER AS OPSD 401.010 TYPE A.
- ENTRANCE / PAVEMENT DESIGN**
 - CONCRETE SIDEWALK AS OPSD 310.01
 - BARRIER CURB AS OPSD 802.11 W/RE SPECIFIED CONSTRUCTION ACCESS RESTRICTED TO LOCATION APPROVED BY CITY OF OTTAWA
- WATERMANS**
 - WATERMANS/SERVICES MIN. COVER 2.4m BELOW FINISHED GRADE.
 - WATER SERVICE TO BE INSTALLED AS PER CITY STANDARDS WITH GRANULAR 1/2" BEDDING AND COVER AS OPSD 110.022
 - THRUST BLOCKS REQUIRED AT ALL TEES, PLUGS, ELBOWS, ETC.
 - PVC WATERMAIN IN SIZES 100mm THROUGH TO 1200mm SHALL BE CLASS 150 DR15 CONFORMING TO ANSA C500. TRACER WIRE SHALL BE INSTALLED ON PVC WATERMAIN WITHIN THE ROAD ALLOWANCE. SIZE 50mm AND SMALLER TO BE TYPE 'C' COPPER
 - MINIMUM HORIZONTAL CLEARANCE BETWEEN SEWER AND WATER SERVICE IS 2.5m WHERE THE WATERMAIN PASSES OVER THE SEWER. MINIMUM VERTICAL CLEARANCE IS 0.15m AND CLEARANCE WHERE THE WATERMAIN PASSES UNDER THE SEWER.
 - CONTRACTOR TO CONFIRM THAT WATER CONNECTION VALVES ARE IN WORKING ORDER.
 - ALL WATERWORKS CONSTRUCTION SHALL CONFORM TO THE CURRENT STANDARDS OF THE CITY OF OTTAWA ENGINEERING DEPT.

ALL SURFACE WORKS WITHIN THE CITY GRID ALLOWANCE WHICH ARE DISTURBED DURING CONSTRUCTION SHALL BE RESTORED TO A CONDITION AT LEAST AS GOOD AS ORIGINAL TO THE SATISFACTION OF THE CITY ENGINEER, ALL AT NO COST TO THE CITY.

WATER SERVICES - TO ENSURE THAT S&T DRINKING WATER QUALITY STANDARDS ARE MET, SERVICE CONNECTIONS AND PRIVATE WATER DISTRIBUTION SYSTEMS ARE SUBJECT TO CLEANING, DISINFECTION, HYDROSTATIC TESTING PROCEDURES. THE CONTRACTOR SHOULD CONTACT THE CITY BUILDING DEPARTMENT FOR TESTING PROCEDURES.

CONTRACTOR TO CONFIRM ALL EXISTING UTILITIES ON SITE (DEPTH AND LOCATION) PRIOR TO START OF CONSTRUCTION. CONTRACTOR TO PROTECT AND/OR RELOCATE ANY UTILITIES AS NECESSARY TO SUIT PROPOSED WORKS. CONTRACTOR TO MAKE ALL NECESSARY ARRANGEMENTS WITH THE APPLICABLE UTILITY COMPANY FOR LOCATES, INSPECTIONS AND RELOCATES.

GRADING AND DRAINAGE NOTES:

- EXISTING GROUND ELEVATIONS TO BE MAINTAINED ALONG PERIMETER OF SITE UNLESS SPECIFIED OTHERWISE.
- ALL DISTURBED AREAS TO BE RESTORED TO EXISTING CONDITION OR BETTER. LANDSCAPE AREAS TO BE RESTORED WITH 100mm TOPSOIL AND NO. 1 HURSBURY SOIL.
- EMBANKMENTS MAXIMUM SLOPE 3:1
- GRASS SURFACE MINIMUM SLOPE 2.0%
- ASPHALT PAVEMENT / CONCRETE SURFACES MINIMUM SLOPE 1%
- ALL SURFACE DRAINAGE SHALL BE SELF CONTAINED, COLLECTED AND DISCHARGED AT A LOCATION TO BE APPROVED PRIOR TO THE ISSUANCE OF A BUILDING PERMIT. DRAINAGE OF ADJACENT PROPERTIES SHALL NOT BE ADVERSELY AFFECTED.
- SILT FENCE TO BE INSTALLED SOUTH AND WEST LIMITS OF THE SITE PRIOR TO START OF CONSTRUCTION. SILT FENCE TO BE MAINTAINED UNTIL SURFACE WORKS ARE COMPLETE AND SITE IS STABILIZED.

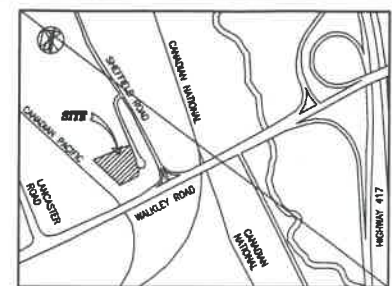
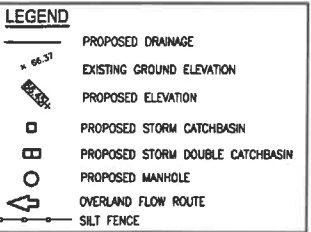
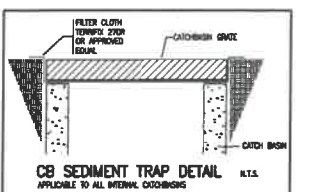
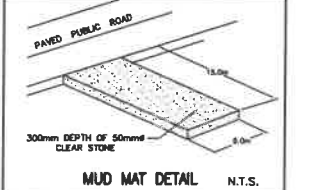

PROJECT STATISTIC

SITE AREA	3,411.28 m ²
GROSS FLOOR AREA	
1st FLOOR	1138.58 m ²
2nd FLOOR/MEZZANINE	101.53 m ²
TOTAL	1240.11 m ²
FLOOR AREA RATIO	1240.11 m ² 36.35%
COVERAGE	1138.58 m ² 33.37%
LANDSCAPED AREA	214.53 m ² 6.29%
PAVED AREA	2,058.17 m ² 60.34%

MUNICIPAL ADDRESS
2920 SHEFFIELD ROAD
LOT # 24, PLAN 4R-7803
OTTAWA, ONTARIO

REFERENCE DRAWINGS:
INFORMATION ON THIS DRAWING TAKEN FROM:
SURVEYOR'S REAL PROPERTY REPORT
PART 1 - PLAN SHOWING
PART OF LOT 24
CONCESSION 3 (OTTAWA FRONT)
(GEOGRAPHIC TOWNSHIP OF GLOUCESTER)
CITY OF OTTAWA
PREPARED BY: J. D. BARNES LIMITED

DATE	Revision	Initial
AUG. 27/09	ADDED STORMCEPTOR	WMS
JULY 27/09	REVISED AS PER CITY COMMENTS	WMS



Consulting Engineering Services - Land Development
SCHAD ENGINEERING
5 Aspen Crescent, Orangeville, Ontario L9V 1A1
BILL SCHAD, P.ENG. Tel:(519) 942-3032 • FAX:(519) 942-3062

ROSS & ANGLIN LTD.
PROPOSED INDUSTRIAL BUILDING
2920 SHEFFIELD ROAD
OTTAWA, ONTARIO

Sheet Title
SITE SERVICING AND GRADING PLAN

Scale	Date	Drawn by	File	Drawing Number
1:250	JULY 2009	WMS	2009-06	SSG1

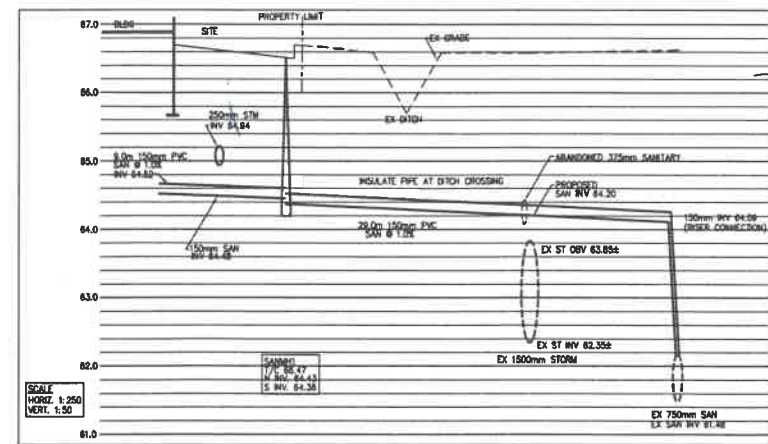

APPENDIX C
WATERMAIN CALCULATIONS

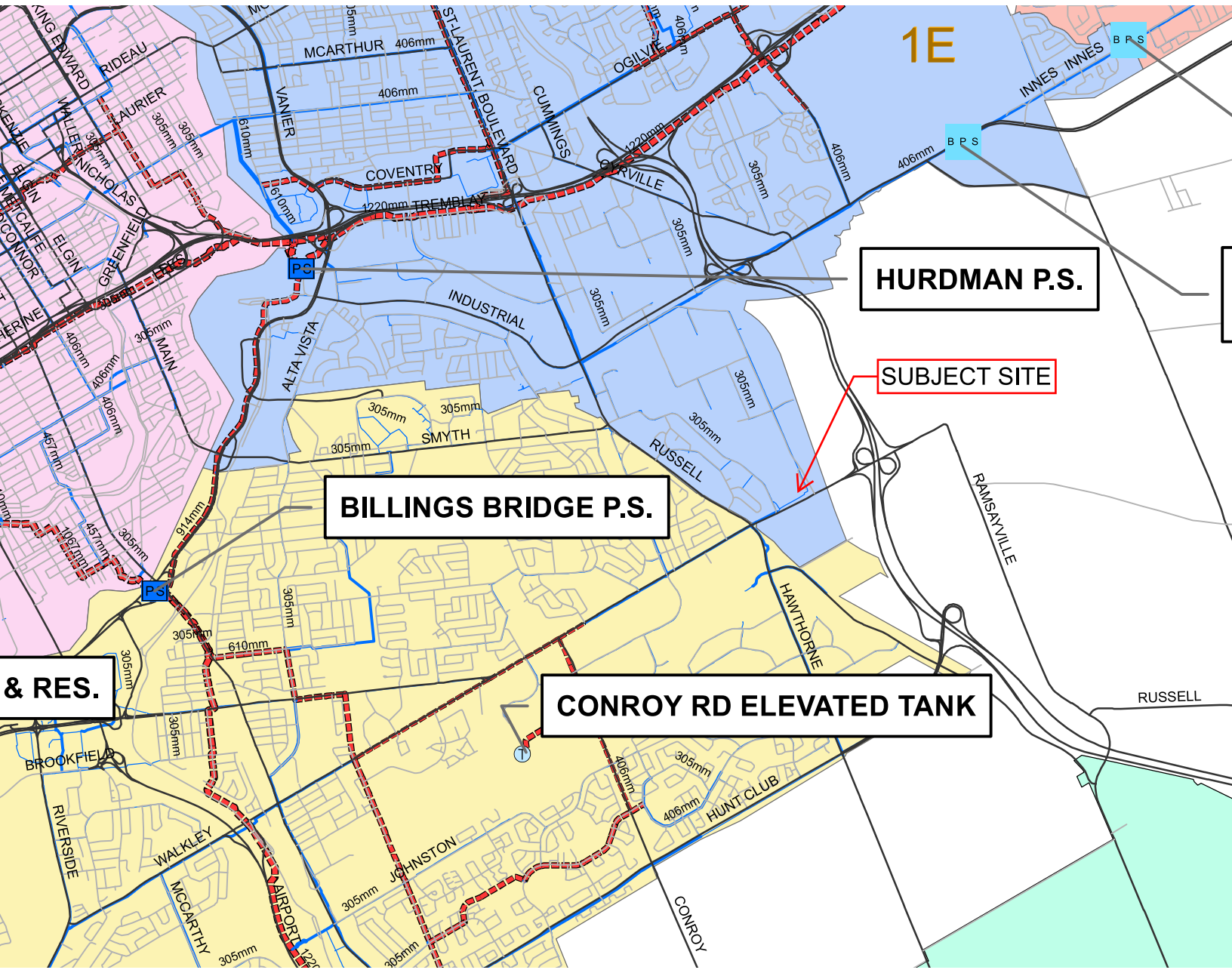

1E

IMNES INNES B P S

HURDMAN P.S.

SUBJECT SITE

BILLINGS BRIDGE P.S.

& RES.

CONROY RD ELEVATED TANK

RUSSELL

BROOKFIELD

HUNT CLUB

JOHNSTON

RIVERSIDE

WALKLEY

MCCARTHY

AIRPORT

CONROY

KING EDWARD

RIDEAU

LAURIER

WALKER

NICHOLAS

ELGIN

MEDICAL

CONNOR

HERVINE

MAIN

GREENFIELD

ALTA VISTA

SMYTH

RUSSELL

HAWTHORNE

INDUSTRIAL

COVENTRY

TREMPER

OGILVIE

CUMMINGS

ST LAURENT BOULEVARD

MCARTHUR

VANIER

COVENTRY

TREMPER

OGILVIE

CUMMINGS

ST LAURENT BOULEVARD

MCARTHUR

VANIER

COVENTRY

TREMPER

OGILVIE

CUMMINGS

ST LAURENT BOULEVARD

MCARTHUR

VANIER

COVENTRY

TREMPER

OGILVIE

McINTOSH PERRY

CP-22-0160 - 2920 Sheffield - Water Demands

Project:	2920 Sheffield
Project No.:	CP-22-0160
Designed By:	FV
Checked By:	AG
Date:	September 15, 2022
Site Area:	0.72 gross ha

Residential	NUMBER OF UNITS		UNIT RATE	
Single Family	homes		3.4	persons/unit
Semi-detached	homes		2.7	persons/unit
Townhouse	homes		2.7	persons/unit
Bachelor Apartment	units		1.4	persons/unit
1 Bedroom Apartment	units		1.4	persons/unit
2 Bedroom Apartment	units		2.1	persons/unit
3 Bedroom Apartment	units		3.1	persons/unit
Average Apartment	units		1.8	persons/unit
Total Population		0 persons		
Commercial		m2		
Industrial - Light		m2		
Industrial - Heavy		7226 m2		

AVERAGE DAILY DEMAND

DEMAND TYPE	AMOUNT	UNITS
Residential	280	L/c/d
Industrial - Light	35,000	L/gross ha/d
Industrial - Heavy	55,000	L/gross ha/d
Shopping Centres	2,500	L/(1000m ² /d)
Hospital	900	L/(bed/day)
Schools	70	L/(Student/d)
Trailer Park with no Hook-Ups	340	L/(space/d)
Trailer Park with Hook-Ups	800	L/(space/d)
Campgrounds	225	L/(campsite/d)
Mobile Home Parks	1,000	L/(Space/d)
Motels	150	L/(bed-space/d)
Hotels	225	L/(bed-space/d)
Tourist Commercial	28,000	L/gross ha/d
Other Commercial	28,000	L/gross ha/d
AVERAGE DAILY DEMAND	Residential	0.00 L/s
	Commercial/Industrial/Institutional	0.46 L/s

MAXIMUM DAILY DEMAND

DEMAND TYPE	AMOUNT	UNITS
Residential	9.5	x avg. day L/c/d
Industrial	1.5	x avg. day L/gross ha/d
Commercial	1.5	x avg. day L/gross ha/d
Institutional	1.5	x avg. day L/gross ha/d
MAXIMUM DAILY DEMAND	Residential	0.00 L/s
	Commercial/Industrial/Institutional	0.69 L/s

MAXIMUM HOUR DEMAND

DEMAND TYPE	AMOUNT	UNITS
Residential	14.3	x avg. day L/c/d
Industrial	1.8	x max. day L/gross ha/d
Commercial	1.8	x max. day L/gross ha/d
Institutional	1.8	x max. day L/gross ha/d
MAXIMUM HOUR DEMAND	Residential	0.00 L/s
	Commercial/Industrial/Institutional	1.24 L/s

WATER DEMAND DESIGN FLOWS PER UNIT COUNT

CITY OF OTTAWA - WATER DISTRIBUTION GUIDELINES, JULY 2010

AVERAGE DAILY DEMAND	0.46	L/s
MAXIMUM DAILY DEMAND	0.69	L/s
MAXIMUM HOUR DEMAND	1.24	L/s

McINTOSH PERRY

CP-22-0160 - 2920 Sheffield - OBC Fire Calculations

Project:	2920 Sheffield
Project No.:	CP-22-0160
Designed By:	FV
Checked By:	AG
Date:	September 15, 2022

Ontario 2006 Building Code Compendium (Div. B - Part 3)

Water Supply for Fire-Fighting - Store/Office & Warehouse Building

Building is classified as Group : D, E and F2 up to 2 Storeys (from table 3.2.2.55)

Building is of noncombustible construction with fire separations and fire-resistance ratings provided in accordance with subsections 3.2.2., including loadbearing walls, columns and arches

From Div. B A-3.2.5.7. of the Ontario Building Code - 3. Building On-Site Water Supply:

(a) $Q = K \times V \times Stot$

where:

Q = minimum supply of water in litres

K = water supply coefficient from Table 1

V = total building volume in cubic metres

Stot = total of spatial coefficient values from the property line exposures on all sides as obtained from the formula:

$Stot = 1.0 + [S_{side1} + S_{side2} + S_{side3} + \dots \text{etc.}]$

K	17	(from Table 1 pg A-31) (Worst case occupancy {E / F2} 'K' value used)				
V	6,728	(Total building volume in m ³)				
Stot	1.0	(From figure 1 pg A-32)				
Q =	114,382.80 L					

				From Figure 1 (A-32)
Snorth	14.815	m	0.0	
Seast	69.19	m	0.0	
Ssouth	24.063	m	0.0	
Swest	10.766	m	0.0	

*approximate distances

From Table 2: Required Minimum Water Supply Flow Rate (L/s)

3600 L/min	if Q > 108,000 L and < 135,000 L
951 gpm	

McINTOSH PERRY

CP-22-0160 - 2920 Sheffield - Fire Underwriters Survey

Project: 2920 Sheffield
 Project No.: CP-22-0160
 Designed By: FV
 Checked By: AG
 Date: September 15, 2022

From the Fire Underwriters Survey (1999)

From Part II – Guide for Determination of Required Fire Flow Copyright I.S.O.:
 Updated per City of Ottawa Technical Bulletin ISTB-2018-02

A. BASE REQUIREMENT (Rounded to the nearest 1000 L/min)

F = 220 x C x √A Where: F = Required fire flow in liters per minute
 C = Coefficient related to the type of construction.
 A = The total floor area in square meters (including all storey's, but excluding basements at least 50 percent below grade) in the building being considered.

Construction Type **Non-Combustible Construction**

C 0.8 A 1,890.0 m²

Calculated Fire Flow 7,651.4 L/min
 8,000.0 L/min

B. REDUCTION FOR OCCUPANCY TYPE (No Rounding)

From note 2, Page 18 of the Fire Underwriter Survey:
 Non-Combustible -25%

Fire Flow 6,000.0 L/min

C. REDUCTION FOR SPRINKLER TYPE (No Rounding)

Non-Sprinklered 0%

Reduction 0.0 L/min

D. INCREASE FOR EXPOSURE (No Rounding)

	Separation Distance (m)	Cons.of Exposed Wall	Length Exposed Adjacent Wall (m)	Height (Stories)	Length-Height Factor	
Exposure 1	20.1 to 30	Non-Combustible	62.9	2	125.8	10%
Exposure 2	20.1 to 30	Non-Combustible	36.58	2	73.2	9%
Exposure 3	>45	Non-Combustible	6.2	2	12.4	0%
Exposure 4	>45	Non-Combustible	43.9	2	87.8	0%
					% Increase*	19%

Increase* 1,140.0 L/min

E. Total Fire Flow (Rounded to the Nearest 1000 L/min)

Fire Flow 7,140.0 L/min
 Fire Flow Required** 7,000.0 L/min

*In accordance with Part II, Section 4, the Increase for separation distance is not to exceed 75%

**In accordance with Section 4 the Fire flow is not to exceed 45,000 L/min or be less than 2,000 L/min

McINTOSH PERRY

CP-22-0160 - 2920 Sheffield - Boundary Condition Unit Conversion

Project: 2920 Sheffield

Project No.: CP-22-0160

Designed By: FV

Checked By: AG

Date: September 15, 2022

Boundary Conditions Unit Conversion

2920 Sheffield

Scenario	Height (m)	Elevation (m)	m H ₂ O	PSI	kPa
Avg. DD	118.0	63.89	54.1	77.0	530.8
Fire Flow (60 L/s or 3600 L/min)	111.2	63.89	47.3	67.3	464.1
Fire Flow (116.7 L/s or 7002 L/min)	106.7	63.89	42.8	60.9	420.0
Peak Hour	109.9	63.89	46.0	65.5	451.4

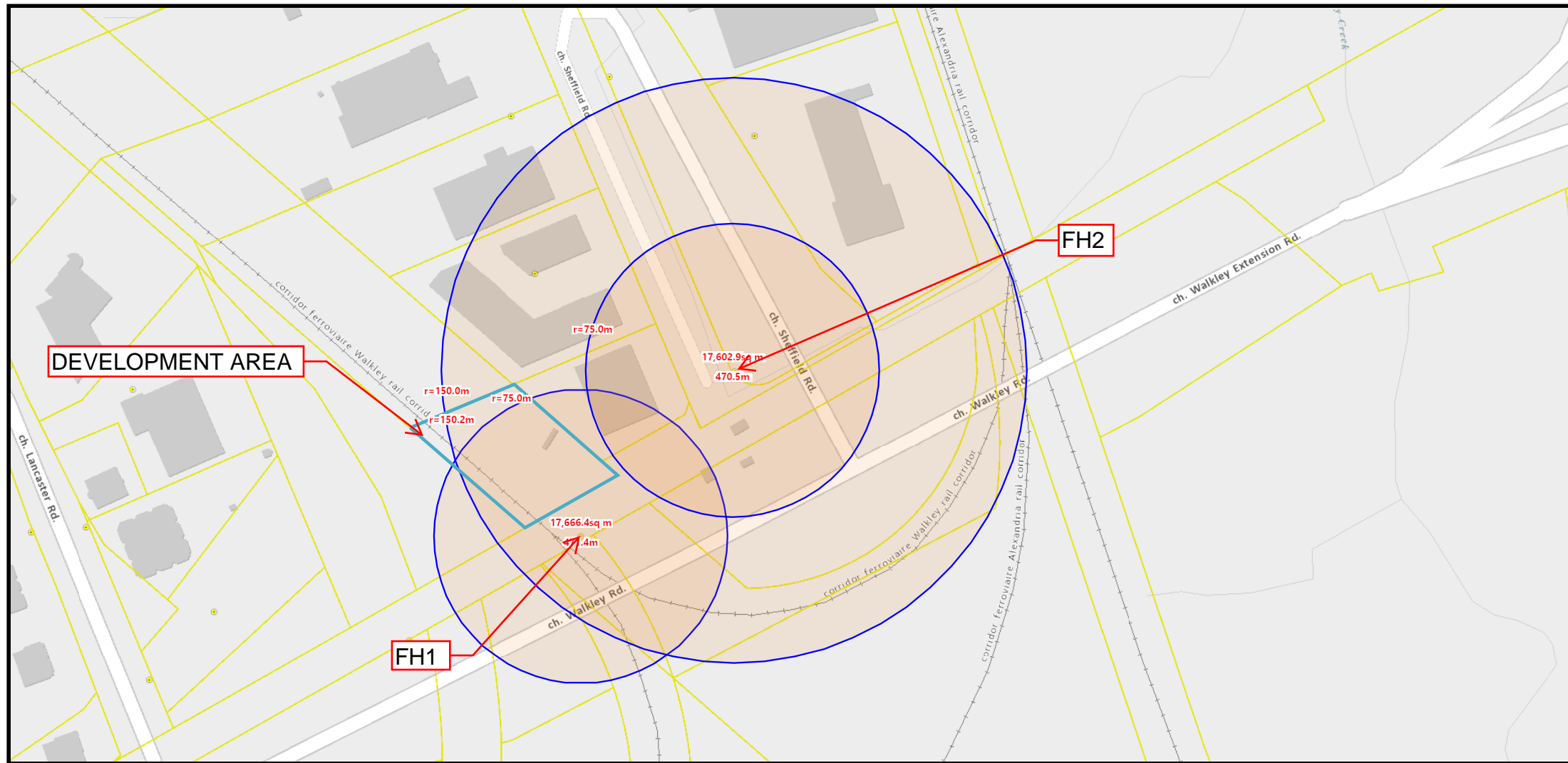

Francis Valenti

From: Harrold, Eric <eric.harrold@ottawa.ca>
Sent: December 15, 2021 3:20 PM
To: Curtis Melanson; Alison Gosling
Subject: RE: 22-0160 - 2920 Sheffield Rd - Servicing Strategy

Follow Up Flag: Follow up
Flag Status: Flagged

Hi Alison and Curtis,

I made a few calls internally and can hopefully provide some clarification. From speaking with the City's water group, apparently access to the hydrant adjacent to Walkley is in fact maintained by the City, and would therefore be available for use in the fire-flow calculations. With regards to the water servicing, only one connection to the watermain is permitted per site, so if the existing 50 mm service is insufficient it will need to be upsized to accommodate the higher demand. Sub-metering is an option if the owner needs to determine the independent usage of each building.

Please let me know if you have any further questions.

Best,
Eric
Eric Harrold, P.Eng
Planning, Infrastructure and Economic Development Department - Services de la Planification, de l'Infrastructure et du Développement Économique
Development Review
City of Ottawa | Ville d'Ottawa
110 Laurier Avenue West, Ottawa, ON | 110, Avenue. Laurier Ouest, Ottawa (Ontario) K1P 1J1
613.580.2424 ext./poste 21447, eric.harrold@ottawa.ca

From: Curtis Melanson <c.melanson@mcintoshperry.com>
Sent: December 15, 2021 11:28 AM
To: Alison Gosling <a.gosling@mcintoshperry.com>; Harrold, Eric <eric.harrold@ottawa.ca>
Subject: RE: 22-0160 - 2920 Sheffield Rd - Servicing Strategy

CAUTION: This email originated from an External Sender. Please do not click links or open attachments unless you recognize the source.

ATTENTION : Ce courriel provient d'un expéditeur externe. Ne cliquez sur aucun lien et n'ouvrez pas de pièce jointe, excepté si vous connaissez l'expéditeur.

Hi Eric,
In addition to Alison's email, what if the site provides a pathway/connection directly to the hydrant with a clause in the site plan agreement about maintenance of the pathway in the winter months?

Just a thought.

Thanks,

Curtis Melanson, C.E.T.

Practice Area Lead, Land Development

115 Walgreen Road, R.R. 3, Carp, ON K0A 1L0

T. 613.714.4621 | F. 613.836.3742 | C. 613.857.0784

c.melanson@mcintoshperry.com | www.mcintoshperry.com

McINTOSH PERRY

Turning Possibilities Into Reality

From: Alison Gosling <a.gosling@mcintoshperry.com>

Sent: December 15, 2021 10:09 AM

To: Harrold, Eric <eric.harrold@ottawa.ca>

Cc: Curtis Melanson <c.melanson@mcintoshperry.com>

Subject: RE: 22-0160 - 2920 Sheffield Rd - Servicing Strategy

Hi Eric,

Thank you for confirming. Do you know what the hydrant is expected to service?

Since the hydrant is not available, it is anticipated that a larger water service might be required. Would the City accept a connection to the 305mm diameter watermain if required for fire servicing? Updated figure attached for clarity.

Thank you,

Alison Gosling, P.Eng.

Project Engineer, Land Development

T. 613.714.4629

McINTOSH PERRY

Turning Possibilities Into Reality

From: Harrold, Eric <eric.harrold@ottawa.ca>

Sent: December 15, 2021 9:06 AM

To: Alison Gosling <a.gosling@mcintoshperry.com>

Cc: Curtis Melanson <c.melanson@mcintoshperry.com>

Subject: RE: 22-0160 - 2920 Sheffield Rd - Servicing Strategy

Hi Alison,

Based on the constraints you identified, I support your proposed servicing strategy of connecting to the 1500 mm storm sewer along Walkley.

With regards to the fire hydrant you identified, I suggest that it is not available, due to limited access during winter months. I do not believe there is a maintained access to this hydrant, and snow removal likely does not occur.

Best,

Eric

Eric Harrold, P.Eng

Planning, Infrastructure and Economic Development Department - Services de la Planification, de l'Infrastructure et du Développement Économique

Development Review

City of Ottawa | Ville d'Ottawa

110 Laurier Avenue West, Ottawa, ON | 110, Avenue. Laurier Ouest, Ottawa (Ontario) K1P 1J1

613.580.2424 ext./poste 21447, eric.harrold@ottawa.ca

From: Alison Gosling <a.gosling@mcintoshperry.com>

Sent: December 14, 2021 3:50 PM

To: Harrold, Eric <eric.harrold@ottawa.ca>

Cc: Curtis Melanson <c.melanson@mcintoshperry.com>

Subject: RE: 22-0160 - 2920 Sheffield Rd - Servicing Strategy

CAUTION: This email originated from an External Sender. Please do not click links or open attachments unless you recognize the source.

ATTENTION : Ce courriel provient d'un expéditeur externe. Ne cliquez sur aucun lien et n'ouvrez pas de pièce jointe, excepté si vous connaissez l'expéditeur.

Hi Eric,

The topographic survey indicates that the existing sewers are 250mm in diameter and are placed at a 0.01% slope. The slope is very minimal and as a result there is no capacity in the existing system to accommodate the development.

In addition to the storm servicing, can you confirm whether the existing hydrant (south west of the site) is available? Based on street view, it appears to be located beneath Walkley Rd. See figure below for reference.

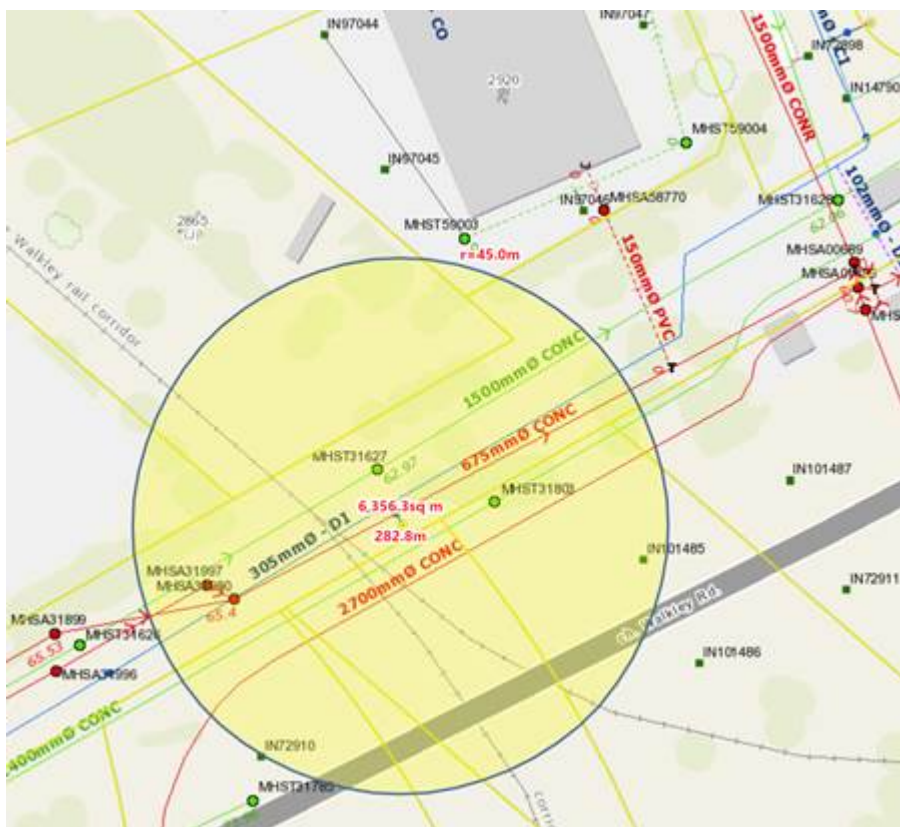

Thank you,

Alison Gosling, P.Eng.

Project Engineer, Land Development

115 Walgreen Road, Carp, ON, K0A 1L0

T. 613.714.4629

a.gosling@mcintoshperry.com | www.mcintoshperry.com

APPENDIX D
SANITARY CALCULATIONS

McINTOSH PERRY

CP-22-0160 - 2920 Sheffield Rd - Sanitary Demands

Project:	2920 Sheffield Rd
Project No.:	CP-22-0160
Designed By:	FV
Checked By:	AG
Date:	2022-09-15
Site Area	0.72 Gross ha

DESIGN PARAMETERS

Institutional/Commercial Peaking Factor	1.5	
Residential Peaking Factor	3.80	* Using Harmon Formula = $1 + (14 / (4 + P^{0.5})) * 0.8$
Industrial Peak Factor (Appendix 4b)	6.90	where P = population in thousands, Harmon's Correction Factor = 0.8
Mannings coefficient (n)	0.013	
Demand (per capita)	280	L/day
Infiltration allowance	0.33	L/s/ha

EXTRANEOUS FLOW ALLOWANCES

Infiltration / Inflow	Flow (L/s)
Dry	0.04
Wet	0.20
Total	0.24

AVERAGE DAILY DEMAND

DEMAND TYPE	AMOUNT	UNITS	POPULATION / AREA	Flow (L/s)
Residential	280	L/c/d	0	0.00
Industrial - Light**	35,000	L/gross ha/d		0.00
Industrial - Heavy**	55,000	L/gross ha/d	0.72	0.46
Commercial / Amenity	2,800	L/(1000m ² /d)	0	0.00
Hospital	900	L/(bed/day)		0
Schools	70	L/(Student/d)		0
Trailer Parks no Hook-Ups	340	L/(space/d)		0
Trailer Park with Hook-Ups	800	L/(space/d)		0
Campgrounds	225	L/(campsite/d)		0
Mobile Home Parks	1,000	L/(Space/d)		0
Motels	150	L/(bed-space/d)		0
Hotels	225	L/(bed-space/d)		0
Office	75	L/7.0m ² /d		0
Tourist Commercial	28,000	L/gross ha/d		0
Other Commercial	28,000	L/gross ha/d		0

AVERAGE RESIDENTIAL FLOW	0.00	L/s
PEAK RESIDENTIAL FLOW	0.00	L/s
Average Industrial	0.46	L/s
PEAK INSTITUTIONAL/COMMERCIAL FLOW	0.00	L/s
PEAK INDUSTRIAL FLOW	3.17	L/s
TOTAL PEAK ICI FLOW	3.17	L/s

TOTAL SANITARY DEMAND

TOTAL ESTIMATED AVERAGE DRY WEATHER FLOW	0.50	L/s
TOTAL ESTIMATED PEAK DRY WEATHER FLOW	3.21	L/s
TOTAL ESTIMATED PEAK WET WEATHER FLOW	3.41	L/s

** PEAK INDUSTRIAL FLOW PER CITY OF OTTAWA SEWER DESIGN GUIDELINES APPENDIX 4B

APPENDIX E
PRE-DEVELOPMENT DRAINAGE PLAN

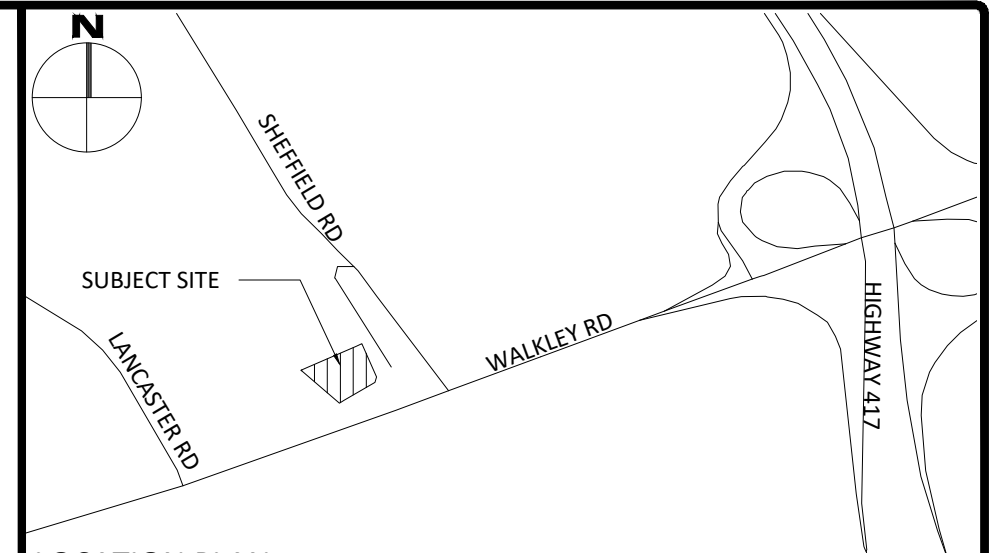
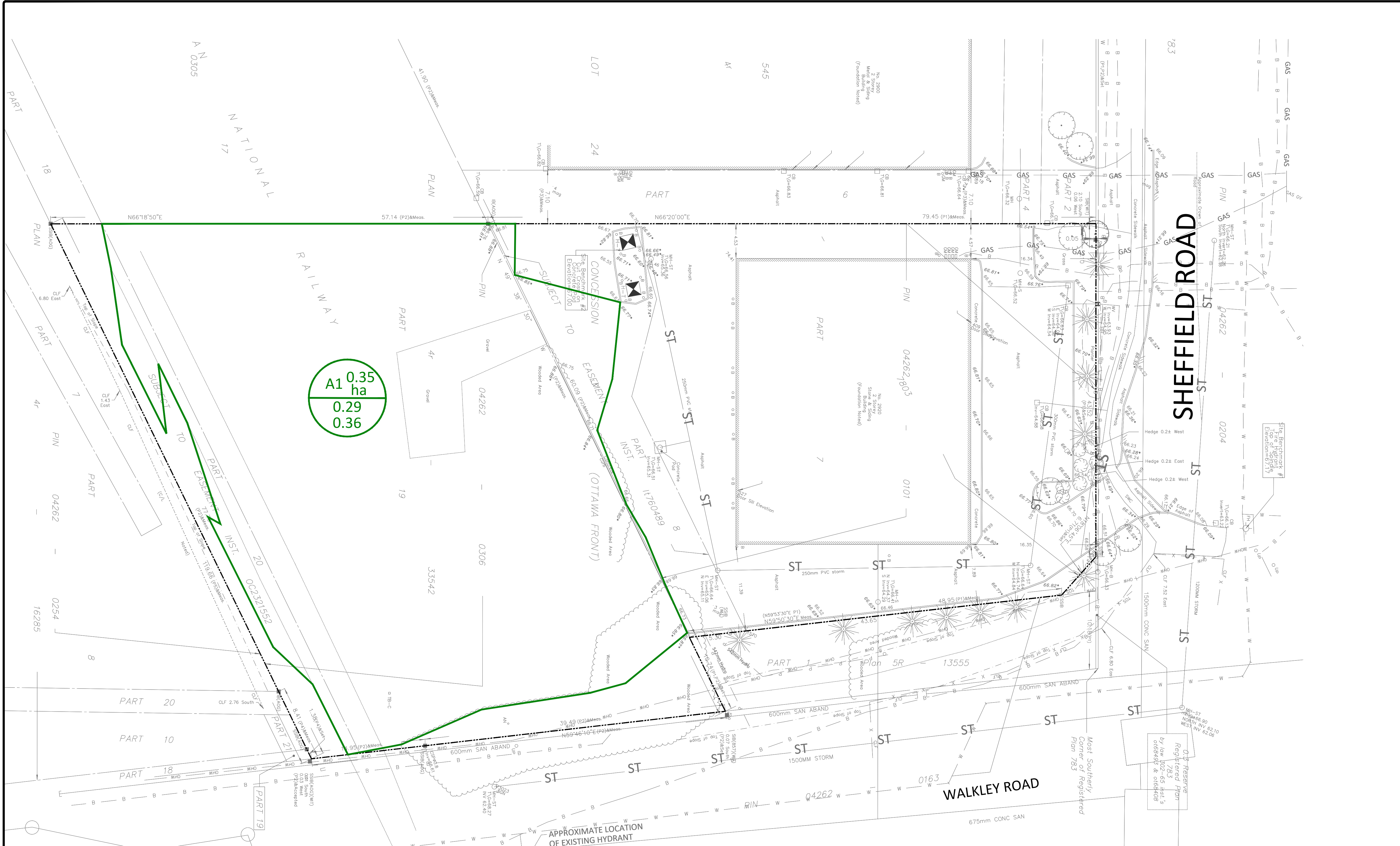

LEGEND

CONCRETE BARRIER CURB	LIMIT OF CONSTRUCTION
CONCRETE WALKWAY	DRAINAGE SWALE
PROPOSED ASPHALT	DRAINAGE DITCH
MUD MAT	UNLESS SPECIFIED
STORM SEWER MANHOLE	SURFACE ELEVATION
CATCHBASIN MANHOLE	SWALE ELEVATION
CATCHBASIN	TOP OF WALL ELEVATION
SANITARY SEWER MANHOLE	BOTTOM OF WALL ELEVATION
FIRE HYDRANT	OVERLAND FLOW ROUTE
WATER VALVE	SILT FENCE BARRIER
WATER METER	STRAW BALE CHECK DAM
REMOTE WATER METER	PAINTED PEDESTRIAN CONNECTION WALKWAY
PROPOSED LANDSCAPING WALL	5-YEAR PONDING
	100-YEAR PONDING
	DRAINAGE AREA LIMIT

FOR REVIEW ONLY
NOT FOR CONSTRUCTION

No.	Revisions	Date
3	REVISED PER CITY COMMENTS	SEP. 15, 2022
2	REVISED PER CITY COMMENTS	JUNE 24, 2022
1	REVISION 1	JAN 28, 2022

Check and verify all dimensions before proceeding with the work. Do not scale drawings.

SCALE 1:250

McINTOSH PERRY
115 Walgreen Road, RR3, Carp, ON K0A 1L0
Tel: 613-836-2184 Fax: 613-836-3742
www.mcintoshperry.com

Client: **ROSS AND ANGLIN LTD**
2920 SHEFFIELD ROAD
OTTAWA, ON K1B 1A4

Project: **2920 SHEFFIELD ROAD**

Drawing Title: **PRE-DEVELOPMENT DRAINAGE PLAN**

Scale: 1:250 Project Number: CCO-22-0160

Drawn By: R.R.R. Checked By: AG

Designed By: C.J.M. Drawing Number: PRE

- GENERAL NOTES**
- THE ORIGINAL TOPOGRAPHY, GROUND ELEVATION AND SURVEY DATA SHOWN ARE SUPPLIED FOR INFORMATION PURPOSES ONLY, AND IMPLY NO GUARANTEE OF ACCURACY. IT SHALL BE THE RESPONSIBILITY OF THE CONTRACTOR TO VERIFY ALL INFORMATION SHOWN.
 - THIS PLAN IS NOT A CADASTRAL SURVEY SHOWING LEGAL PROPERTY BOUNDARIES AND EASEMENTS. THE PROPERTY BOUNDARIES SHOWN HEREON HAVE BEEN DERIVED FROM INFORMATION SUPPLIED BY (OR SHOWN ON) AND CANNOT BE RELIED UPON TO BE ACCURATE OR COMPLETE. THE PRECISE LOCATION OF THE CURRENT PROPERTY BOUNDARIES AND EASEMENTS CAN ONLY BE DETERMINED BY AN UP-TO-DATE LAND TITLES SEARCH AND A SUBSEQUENT CADASTRAL SURVEY PERFORMED AND CERTIFIED BY AN ONTARIO LAND SURVEYOR.
 - THE CONTRACTOR IS TO OBTAIN AND PAY FOR ALL NECESSARY PERMITS AND APPROVALS FROM THE CITY BEFORE COMMENCING CONSTRUCTION.
 - THE CONTRACTOR IS RESPONSIBLE FOR ALL LAYOUT.
 - THE CONTRACTOR IS TO DETERMINE THE EXACT LOCATION, SIZE, MATERIAL AND ELEVATION OF ALL EXISTING UTILITIES PRIOR TO COMMENCING CONSTRUCTION. PROTECT AND ASSUME ALL RESPONSIBILITY FOR EXISTING UTILITIES WHETHER OR NOT SHOWN ON THESE DRAWINGS. IF THERE IS ANY DISCREPANCY THE CONTRACTOR IS TO NOTIFY THE ENGINEER PROMPTLY.
 - RESTORE ALL TRENCHES AND SURFACES OF PUBLIC ROAD ALLOWANCES TO CONDITION EQUAL OR BETTER THAN ORIGINAL CONDITION AND TO THE SATISFACTION OF THE CITY AUTHORITIES.
 - EXCAVATE AND DISPOSE OF ALL EXCESS EXCAVATED MATERIAL SUCH AS ASPHALT, CURBING AND DEBRIS, OFF SITE AS DIRECTED BY THE ENGINEER AND THE CITY.
 - TOPSOIL TO BE STRIPPED AND STOCKPILED FOR REHABILITATION. CLEAN FILL TO BE PLACED IN FILL AREAS AND COMPACTED TO 95% STANDARD PROCTOR DENSITY.
 - ALL DISTURBED AREAS TO BE RESTORED TO ORIGINAL CONDITION OR BETTER UNLESS OTHERWISE SPECIFIED.

- THE CONTRACTOR SHALL BE RESPONSIBLE FOR ALL TRAFFIC CONTROL AND SAFETY MEASURES DURING THE CONSTRUCTION PERIOD, INCLUDING THE SUPPLY, INSTALLATION, AND REMOVAL OF ALL NECESSARY SIGNAGE, DELINEATORS, MARKERS AND BARRIERS.
- DO NOT ALTER GRADING OF THE SITE WITHOUT PRIOR APPROVAL OF THE ENGINEER/CITY.
- ALL ROADWAY, PARKING LOT, AND GRADING WORKS TO BE UNDERTAKEN IN ACCORDANCE WITH CITY STANDARDS AND SPECIFICATIONS. THE CONTRACTOR IS TO PROVIDE POSITIVE DRAINAGE AWAY FROM THE BUILDING.
- CONTACT THE CITY FOR INSPECTION OF ROUGH GRADING OF PARKING LOTS, ROADWAYS AND LANDSCAPED AREAS PRIOR TO PLACEMENT OF ASPHALT AND TOPSOIL. ALL DEFICIENCIES NOTED SHALL BE RECTIFIED TO THE CITY'S SATISFACTION PRIOR TO PLACEMENT OF ANY ASPHALT, TOPSOIL, SEED & MULCH AND/OR SOD.
- ALL DIMENSIONS AND INVERTS MUST BE VERIFIED PRIOR TO CONSTRUCTION, IF THERE IS ANY DISCREPANCY THE CONTRACTOR IS TO NOTIFY THE ENGINEER PROMPTLY.
- ELECTRICAL, GAS, TELEPHONE AND TELEVISION SERVICE LOCATIONS ARE SUBJECT TO THE INDIVIDUAL AGENCY:
 - ELECTRICAL SERVICE - HYDRO ONE,
 - GAS SERVICE - ENBRIDGE,
 - TELEPHONE SERVICE - BELL CANADA,
 - TELEVISION SERVICE - ROGERS.
- INSTALLATION TO BE IN ACCORDANCE WITH CURRENT CODES AND STANDARDS OF APPROVAL AGENCIES HYDRO ONE, BELL AND THE CITY.
- CONTRACTOR TO ENSURE ALL APPLICABLE OPS SPECIFICATIONS ARE FOLLOWED DURING CONSTRUCTION.
- ALL PROPOSED CURB TO BE CONCRETE BARRIER CURB UNLESS OTHERWISE SPECIFIED.
- THIS PLAN MUST BE READ IN CONJUNCTION WITH THE GEOTECHNICAL INVESTIGATION COMPLETED BY QUALITAS OUTAOUAIS, DATED JANUARY 2007.

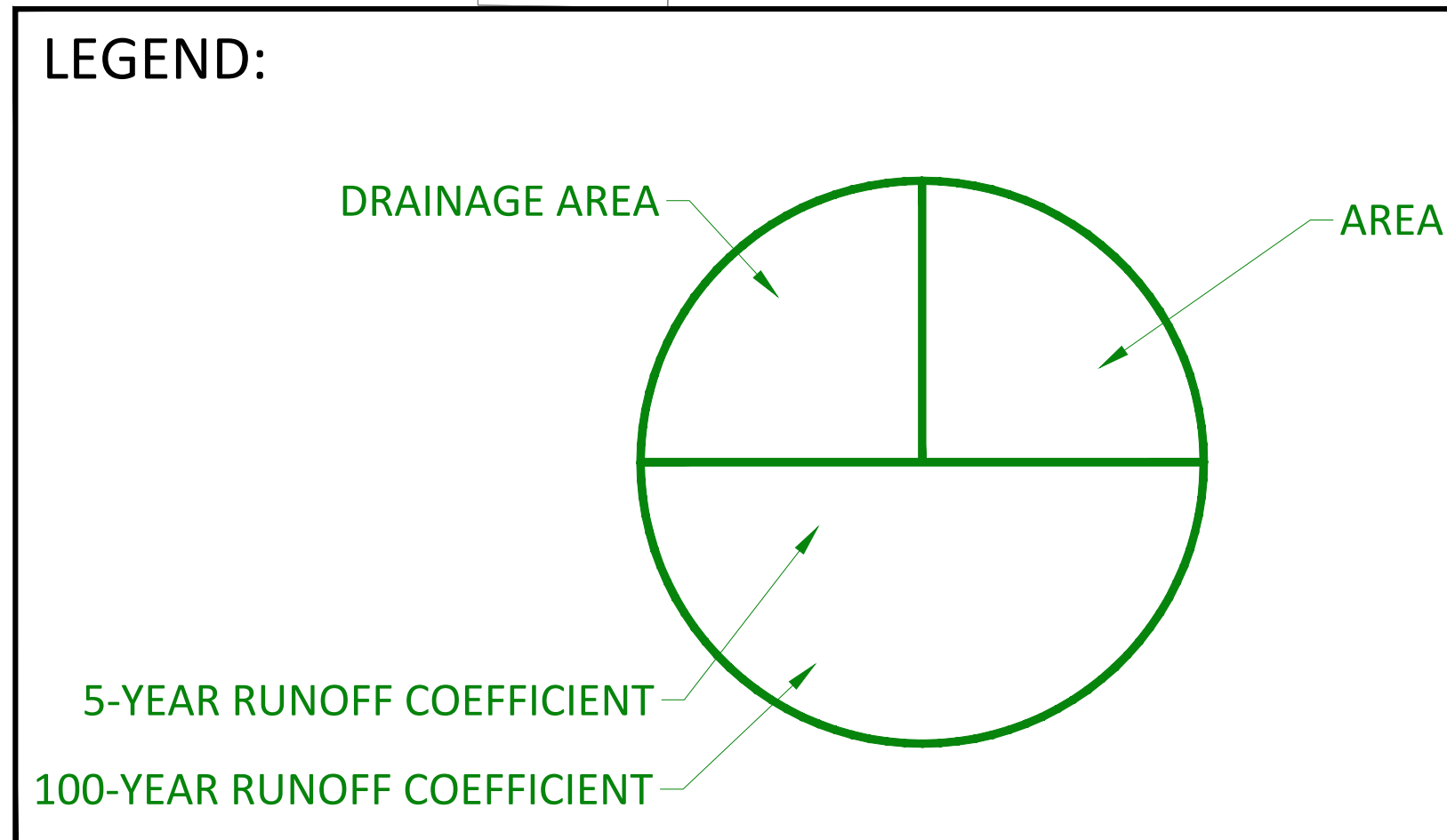

FILENAME: I:\01\Drawings\01 Project - Predevelopment\2022\0160\CCO-22-0160-01-00 Ross & Anglin - R.R.R. - 2920 Sheffield Road\11 - Drainage\CCO-22-0160 - Presentation.dwg
 DATE PLOTTED: Thursday, September 15, 2022, 1:55:45 PM
 USER: R.R.R.
 PLOT DEVICE: HP DesignJet T1100e

APPENDIX F
POST-DEVELOPMENT DRAINAGE PLAN

APPENDIX G
STORMWATER MANAGEMENT CALCULATIONS

McINTOSH PERRY

CO-22-0160 - 2920 Sheffield- SWM Calculations

1 of 5

Tc (min)	Intensity (mm/hr)	
	5-Year	100-Year
10	104.2	178.6
10	104.2	178.6

C-Values	
Impervious	0.90
Gravel	0.60
Pervious	0.20

Pre-Development Runoff Coefficient

Drainage Area	Impervious Area (m ²)	Gravel (m ²)	Pervious Area (m ²)	Average C (5-year)	Average C (100-year)
A1	169.36	525.02	2,843.37	0.29	0.36

Pre-Development Runoff Calculations

Drainage Area	Area (ha)	C 5-Year	C 100-Year	Tc (min)	Q (L/s)	
					5-Year	100-Year
A1	0.35	0.29	0.36	10	30.01	63.24
Total	0.35				30.01	63.24

Post-Development Runoff Coefficient

Drainage Area	Impervious Area (m ²)	Gravel (m ²)	Pervious Area (m ²)	Average C (5-year)	Average C (100-year)	
B1	351	0	58	0.80	0.89	Surface - Uncontrolled
B2	1,774	0	389	0.77	0.86	Surface - Controlled
B3	945	0	0	0.90	1.00	Roof

Post-Development Runoff Calculations

Drainage Area	Area (ha)	C 5-Year	C 100-Year	Tc (min)	Q (L/s)		
					5-Year	100-Year	
B1	0.04	0.80	0.89	10	9.49	18.15	Surface - Uncontrolled
B2	0.22	0.77	0.86	10	48.49	92.87	Surface - Controlled
B3	0.09	0.90	1.00	10	24.64	46.92	Roof
Total	0.35				57.98	111.01	

Required Restricted Flow

Drainage Area	Area (ha)	C 5-Year	Tc (min)	Q (L/s)
				5-Year
A1	0.35	0.29	10	30.01

Post-Development Restricted Runoff Calculations

Drainage Area	Unrestricted Flow (L/S)		Restricted Flow (L/S)		Storage Required (m ³)		Storage Provided (m ³)	
	5-year	100-Year	5-Year	100-Year	5-Year	100-Year	5-Year	100-Year
B1	9.49	18.15	9.49	18.15				
B2	48.49	92.87	10.39	10.59	26.8	68.3	33.6	73.2
B3	24.64	46.92	1.26	1.26	24.2	54.2	31.9	63.8
Total	82.62	157.94	21.14	30.00				

McINTOSH PERRY

CO-22-0160 - 2920 Sheffield- SWM Calculations

2 of 5

Storage Requirements for Area B2

5-Year Storm Event

Tc (min)	I (mm/hr)	Runoff (L/s) B2	Allowable Outflow (L/s)	Runoff to be Stored (L/s)	Storage Required (m ³)
10	104.2	48.49	10.39	38.10	22.86
20	70.3	32.72	10.39	22.33	26.79
30	53.9	25.08	10.39	14.69	26.45
40	44.2	20.57	10.39	10.18	24.43
50	37.7	17.54	10.39	7.15	21.46

Maximum Storage Required 5-year = 27 m³

100-Year Storm Event

Tc (min)	I (mm/hr)	Runoff (L/s) B2	Allowable Outflow (L/s)	Runoff to be Stored (L/s)	Storage Required (m ³)
10	178.6	92.89	10.59	82.30	49.38
20	120.0	62.41	10.59	51.82	62.19
30	91.9	47.80	10.59	37.21	66.97
40	75.1	39.06	10.59	28.47	68.33
50	64.0	33.29	10.59	22.70	68.09
60	55.9	29.07	10.59	18.48	66.54
70	49.8	25.90	10.59	15.31	64.30
80	45.0	23.40	10.59	12.81	61.51
90	41.1	21.38	10.59	10.79	58.24
100	37.9	19.71	10.59	9.12	54.73

Maximum Storage Required 100-year = 68 m³

5-Year Storm Event Storage Summary

Water Elev. (m) = 66.62					
Location	T/G	INV. (out)	Depth (m)	Head (m)	Volume (m ³)
CBMH3	66.40	64.04	0.22	2.46	33.6
CBMH4	66.40	63.86	0.22	2.63	

Storage Available (m³) = 33.61 *
Storage Required (m³) = 26.79

100-Year Storm Event Storage Summary

Water Elev. (m) = 66.70					
Location	T/G	INV. (out)	Depth (m)	Head (m)	Volume (m ³)
CBMH3	66.40	64.04	0.30	2.54	73.2
CBMH4	66.40	63.86	0.30	2.71	

Storage Available (m³) = 73.24 *
Storage Required (m³) = 68.33

*Available Storage calculated from AutoCAD

McINTOSH PERRY

CO-22-0160 - 2920 Sheffield- SWM Calculations

3 of 5

Storage Requirements for Area B3

5-Year Storm Event

Tc (min)	I (mm/hr)	Runoff (L/s) B3	Allowable Outflow (L/s)	Runoff to be Stored (L/s)	Storage Required (m ³)
40	44.2	10.45	1.26	9.19	22.06
50	37.7	8.92	1.26	7.65	22.96
60	32.9	7.78	1.26	6.52	23.47
70	29.4	6.95	1.26	5.69	23.90
80	26.6	6.29	1.26	5.03	24.14
90	24.3	5.75	1.26	4.49	24.22
100	22.4	5.30	1.26	4.04	24.22
110	20.8	4.92	1.26	3.66	24.14
120	19.5	4.61	1.26	3.35	24.12
130	18.3	4.33	1.26	3.07	23.92

Maximum Storage Required 5-year = 24 m³

100-Year Storm Event

Tc (min)	I (mm/hr)	Runoff (L/s) B3	Allowable Outflow (L/s)	Runoff to be Stored (L/s)	Storage Required (m ³)
150	27.6	7.25	1.26	5.99	53.92
160	26.2	6.89	1.26	5.62	53.98
170	25.0	6.57	1.26	5.31	54.14
180	23.9	6.28	1.26	5.02	54.20
190	22.9	6.02	1.26	4.76	54.22
200	22.0	5.78	1.26	4.52	54.23
210	21.1	5.54	1.26	4.28	53.97
220	20.4	5.36	1.26	4.10	54.11
230	19.7	5.18	1.26	3.92	54.03
240	19.0	4.99	1.26	3.73	53.73

Maximum Storage Required 100-year = 54 m³

5-Year Storm Event Storage Summary

Roof Storage			
Location	Area*	Depth	Volume (m ³)
Roof	708.75	0.045	31.89

Storage Available (m³) = 31.89
Storage Required (m³) = 24.22

100-Year Storm Event Storage Summary

Roof Storage			
Location	Area*	Depth	Volume (m ³)
Roof	708.75	0.090	63.79

Storage Available (m³) = 63.79
Storage Required (m³) = 54.23

*Area is 75% of the total roof area

McINTOSH PERRY

Roof Drain Flow (B3)

Roof Drains Summary		
Type of Control Device	Watts Drainage - Accutrol Weir (Fully Closed)	
Number of Roof Drains	4	
	5-Year	100-Year
Rooftop Storage (m ³)	31.89	63.79
Storage Depth (mm)	0.045	0.090
Flow (Per Roof Drain) (L/s)	0.32	0.32
Total Flow (L/s)	1.26	1.26

Flow Rate Vs. Build-Up (One Weir)	
Depth (mm)	Flow (L/s)
15	0.18
20	0.24
25	0.30
30	0.36
35	0.42
40	0.48
45	0.54
50	0.60
55	0.66

5 Year Storm

100 Year Storm

Roof Drain Flow		
Flow (l/s)	Storage Depth (mm)	Drains Flow (l/s)
0.19	15	0.76
0.25	20	1.01
0.32	25	1.26
0.32	30	1.26
0.32	35	1.26
0.32	40	1.26
0.32	45	1.26
0.32	50	1.26
0.32	55	1.26
0.32	60	1.26
0.32	65	1.26
0.32	70	1.26
0.32	75	1.26
0.32	80	1.26
0.32	85	1.26
0.32	90	1.26
0.32	95	1.26
0.32	100	1.26
0.32	105	1.26
0.32	110	1.26
0.32	115	1.26
0.32	120	1.26
0.32	125	1.26
0.32	130	1.26
0.32	135	1.26
0.32	140	1.26
0.32	145	1.26
0.32	150	1.26

100 Year Storm

*Roof Drain model to be Accutrol Weirs, See attached sheets
 *Roof Drain Flow information taken from Watts Drainage website

CALCULATING ROOF FLOW EXAMPLES

1 roof drain during a 5 year storm
 elevation of water = 25mm
 Flow leaving 1 roof drain = (1 x 0.30 L/s) = 0.30 L/s

1 roof drain during a 100 year storm
 elevation of water = 50mm
 Flow leaving 1 roof drain = (1 x 0.60 L/s) = 0.60 L/s

4 roof drains during a 5 year storm
 elevation of water = 25mm
 Flow leaving 4 roof drains = (4 x 0.30 L/s) = 1.20 L/s

4 roof drains during a 100 year storm
 elevation of water = 50mm
 Flow leaving 4 roof drains = (4 x 0.60 L/s) = 2.40 L/s

Note: The flow leaving through a restricted roof drain is based on flow vs. head information

McINTOSH PERRY

Time of Concentration Pre-Development

Drainage Area ID	Sheet Flow Distance (m)	Slope of Land (%)	Tc (min) (5-Year)	Tc (min) (100-Year)
A1	43	2.00	6	4

Therefore, a Tc of 10 can be used

$$Tc = (3.26(1.1-c)L^{0.5}/S^{0.33})$$

c = Balanced Runoff Coefficient

L = Length of drainage area

S = Average slope of watershed

STORM SEWER DESIGN SHEET

PROJECT: CO-22-0160
 LOCATION: 2920 Sheffield
 CLIENT:



LOCATION				CONTRIBUTING AREA (ha)				RATIONAL DESIGN FLOW										SEWER DATA										
1	2	3	4	5	6	7	8	9	10	11	12	13	14	15	16	17	18	19	20	21	22	23	24	25	26	27	28	
STREET	AREA ID	FROM MH	TO MH	C-VALUE	AREA	INDIV AC	CUMUL AC	INLET (min)	TIME IN PIPE	TOTAL (min)	i (5) (mm/hr)	i (10) (mm/hr)	i (100) (mm/hr)	5yr PEAK FLOW (L/s)	10yr PEAK FLOW (L/s)	100yr PEAK FLOW (L/s)	FIXED FLOW (L/s)	DESIGN FLOW (L/s)	CAPACITY (L/s)	LENGTH (m)	PIPE SIZE (mm)			SLOPE (%)	VELOCITY (m/s)	AVAIL CAP (5yr)		
																					DIA	W	H			(L/s)	(%)	
	B2	CB1	CBMH1	0.66	0.02	0.01	0.01	10.00	0.15	10.15	104.19	122.14	178.56	3.98					3.98	90.33	16.20	250			2.12	1.783	86.35	95.59%
	B2	CBMH1	CBMH2	0.66	0.02	0.01	0.02	10.15	0.11	10.26	103.40	121.21	177.19	7.10					7.10	82.77	10.56	250			1.78	1.633	75.67	91.42%
	B2	CBMH2	CBMH3	0.66	0.07	0.04	0.07	10.26	0.72	10.98	102.84	120.55	176.22	19.72					19.72	43.87	37.35	250			0.50	0.866	24.15	55.05%
	B2	CBMH3	CBMH4	0.66	0.07	0.05	0.12	10.98	0.37	11.35	99.29	116.37	170.09	32.12					32.12	52.27	22.92	250			0.71	1.032	20.15	38.55%
	B2	CBMH4	OGS	0.66	0.07	0.05	0.17	11.35	0.14	11.49	97.57	114.34	167.10	44.85				7.78	7.78	61.73	10.22	250			0.99	1.218	53.95	87.40%
	B3	Roof	OGS	0.90	0.09	0.09	0.09	10.00	0.23	10.23	104.19	122.14	178.56	24.64				2.10	2.10	62.04	17.22	250			1.00	1.224	59.94	96.62%
	B2+B3	OGS	Tie-In	0.00	0.00		0.25	11.49	0.09	11.58	96.94	113.60	166.01	67.47					9.88	124.39	13.70	250			4.02	2.455	114.51	92.06%
Definitions: Q = 2.78CIA, where: Q = Peak Flow in Litres per Second (L/s) A = Area in Hectares (ha) i = Rainfall intensity in millimeters per hour (mm/hr) [i = 998.071 / (TC+6.053)^0.814] 5 YEAR [i = 1174.184 / (TC+6.014)^0.816] 10 YEAR [i = 1735.688 / (TC+6.014)^0.820] 100 YEAR				Notes: 1. Mannings coefficient (n) = 0.013				Designed: FV				No. 1. Submission 1 2. Revised per New Site Plan				Revision				Date 2022-01-28 2022-09-15								
								Checked: AG																				
								Project No.: CO-22-0160												Date: 2022-01-28				Sheet No: 1 of 1				



Adjustable Accutrol Weir

Tag: _____

Adjustable Flow Control for Roof Drains

ADJUSTABLE ACCUTROL (for Large Sump Roof Drains only)

For more flexibility in controlling flow with heads deeper than 2", Watts Drainage offers the Adjustable Accutrol. The Adjustable Accutrol Weir is designed with a single parabolic opening that can be covered to restrict flow above 2" of head to less than 5 gpm per inch, up to 6" of head. To adjust the flow rate for depths over 2" of head, set the slot in the adjustable upper cone according to the flow rate required. Refer to Table 1 below.
 Note: Flow rates are directly proportional to the amount of weir opening that is exposed.

EXAMPLE:

For example, if the adjustable upper cone is set to cover 1/2 of the weir opening, flow rates above 2" of head will be restricted to 2-1/2 gpm per inch of head.

Therefore, at 3" of head, the flow rate through the Accutrol Weir that has 1/2 the slot exposed will be:
 [5 gpm (per inch of head) x 2 inches of head] + 2-1/2 gpm (for the third inch of head) = 12-1/2 gpm.

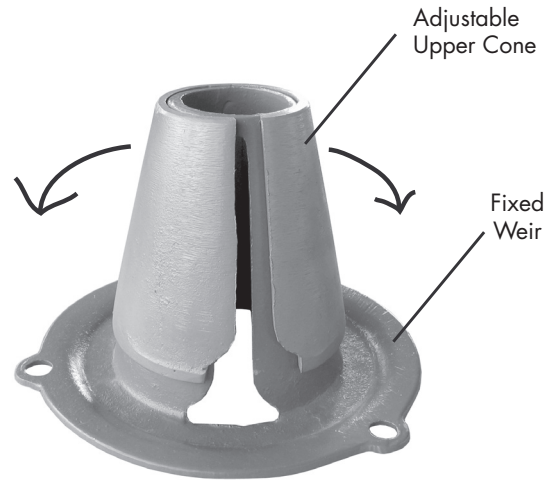
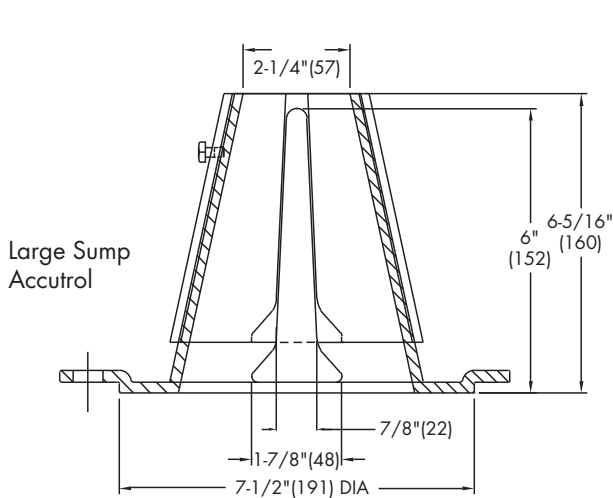

1/2 Weir Opening Exposed Shown Above

TABLE 1. Adjustable Accutrol Flow Rate Settings

Weir Opening Exposed	1"	2"	3"	4"	5"	6"
	Flow Rate (gallons per minute)					
Fully Exposed	5	10	15	20	25	30
3/4	5	10	13.75	17.5	21.25	25
1/2	5	10	12.5	15	17.5	20
1/4	5	10	11.25	12.5	13.75	15
Closed	5	5	5	5	5	5

Job Name _____
 Job Location _____
 Engineer _____

Contractor _____
 Contractor's P.O. No. _____
 Representative _____

Watts product specifications in U.S. customary units and metric are approximate and are provided for reference only. For precise measurements, please contact Watts Technical Service. Watts reserves the right to change or modify product design, construction, specifications, or materials without prior notice and without incurring any obligation to make such changes and modifications on Watts products previously or subsequently sold.

USA: Tel: (800) 338-2581 • Fax: (828) 248-3929 • Watts.com
 Canada: Tel: (905) 332-4090 • Fax: (905) 332-7068 • Watts.ca
 Latin America: Tel: (52) 81-1001-8600 • Fax: (52) 81-8000-7091 • Watts.com



Volume III: TEMPEST INLET CONTROL DEVICES

Municipal Technical
Manual Series



SECOND EDITION

LMF (Low to Medium Flow) ICD

HF (High Flow) ICD

MHF (Medium to High Flow) ICD



IPEX

by aliaxis

IPEX Tempest™ Inlet Control Devices

Municipal Technical Manual Series

Vol. I, 2nd Edition

© 2018 by IPEX. All rights reserved. No part of this book may be used or reproduced in any manner whatsoever without prior written permission.

For information contact: IPEX, Marketing,
1425 North Service Road East, Oakville, Ontario, Canada, L6H 1A7

The information contained here within is based on current information and product design at the time of publication and is subject to change without notification. IPEX does not guarantee or warranty the accuracy, suitability for particular applications, or results to be obtained therefrom.

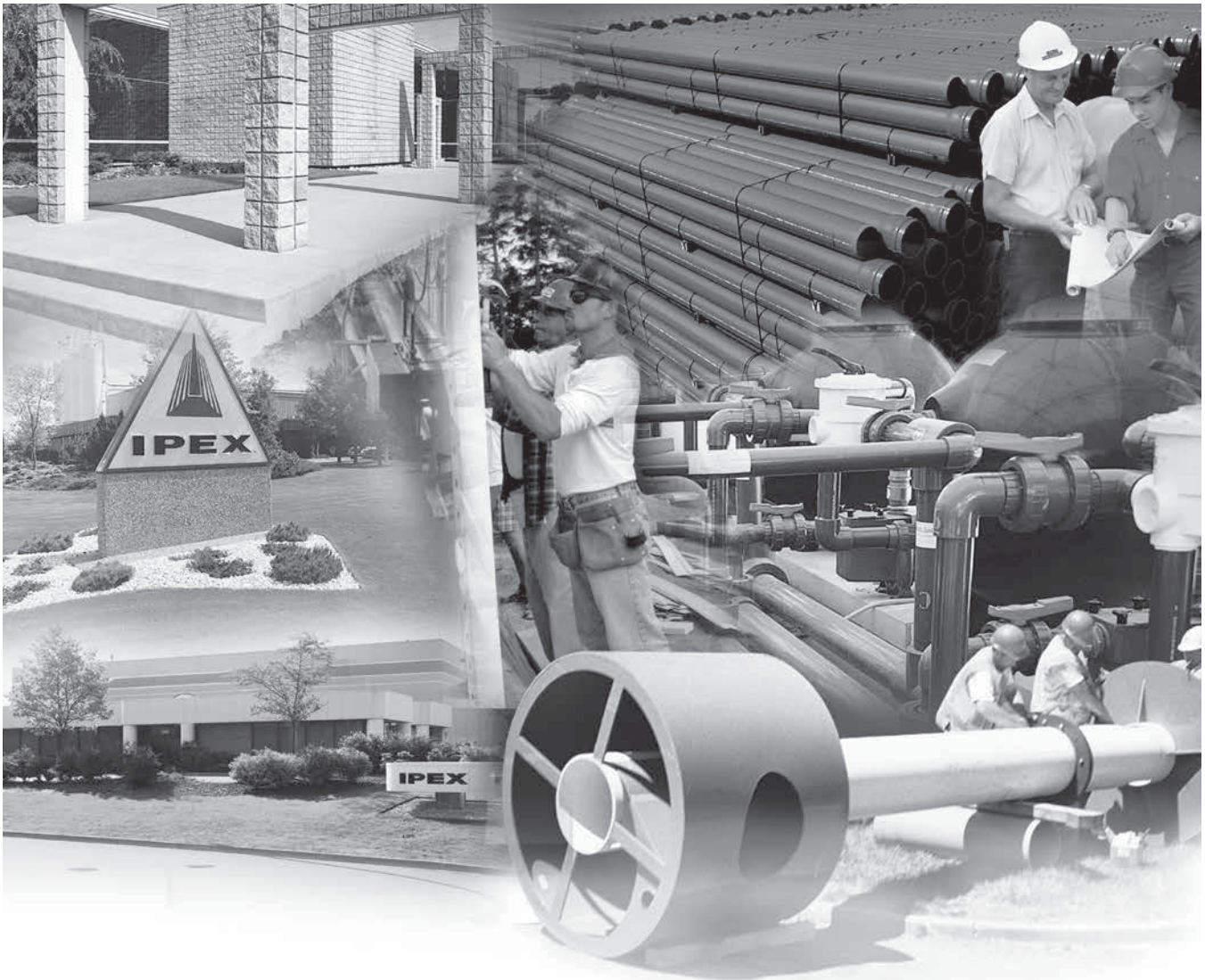

ABOUT IPEX

At IPEX, we have been manufacturing non-metallic pipe and fittings since 1951. We formulate our own compounds and maintain strict quality control during production. Our products are made available for customers thanks to a network of regional stocking locations throughout North America. We offer a wide variety of systems including complete lines of piping, fittings, valves and custom-fabricated items.

More importantly, we are committed to meeting our customers' needs. As a leader in the plastic piping industry, IPEX continually develops new products, modernizes manufacturing facilities and acquires innovative process technology. In addition, our staff take pride in their work, making available to customers their extensive thermoplastic knowledge and field experience. IPEX personnel are committed to improving the safety, reliability and performance of thermoplastic materials. We are involved in several standards committees and are members of and/or comply with the organizations listed on this page.

For specific details about any IPEX product, contact our customer service department.

CONTENTS

TEMPEST INLET CONTROL DEVICES Technical Manual

About IPEX

Section One:	Product Information: TEMPEST Low, Medium Flow (LMF) ICD	
	Purpose.....	4
	Product Description.....	4
	Product Function.....	4
	Product Construction.....	4
	Product Applications.....	4
	Chart 1: LMF 14 Preset Flow Curves.....	5
	Chart 2: LMF Flow Vs. ICD Alternatives.....	5
	Product Installation	
	Instructions to assemble a TEMPEST LMF ICD into a square catch basin:.....	6
	Instructions to assemble a TEMPEST LMF ICD into a round catch basin:.....	6
	Product Technical Specification	
	General.....	7
	Materials.....	7
	Dimensioning.....	7
	Installation.....	7
Section Two:	Product Information: TEMPEST High Flow (HF) & Medium, High Flow (MHF) ICD	
	Product Description.....	8
	Product Function.....	8
	Product Construction.....	8
	Product Applications.....	8
	Chart 3: HF & MHF Preset Flow Curves.....	9
	Product Installation	
	Instructions to assemble a TEMPEST HF or MHF ICD into a square catch basin:.....	10
	Instructions to assemble a TEMPEST HF or MHF ICD into a round catch basin:.....	10
	Instructions to assemble a TEMPEST HF Sump into a square or round catch basin:...	11
	Product Technical Specification	
	General.....	11
	Materials.....	11
	Dimensioning.....	11
	Installation.....	11

PRODUCT INFORMATION: TEMPEST LOW, MEDIUM FLOW (LMF) ICD

Purpose

To control the amount of storm water runoff entering a sewer system by allowing a specified flow volume out of a catch basin or manhole at a specified head. This approach conserves pipe capacity so that catch basins downstream do not become uncontrollably surcharged, which can lead to basement floods, flash floods and combined sewer overflows.

Product Description

Our LMF ICD is designed to accommodate catch basins or manholes with sewer outlet pipes 6" in diameter and larger. Any storm sewer larger than 12" may require custom modification. However, IPEX can custom build a TEMPEST device to accommodate virtually any storm sewer size.

Available in 14 preset flow curves, the LMF ICD has the ability to provide flow rates: 2lps – 17lps (31gpm – 270gpm)

Product Function

The LMF ICD vortex flow action allows the LMF ICD to provide a narrower flow curve using a larger orifice than a conventional orifice plate ICD, making it less likely to clog. When comparing flows at the same head level, the LMF ICD has the ability to restrict more flow than a conventional ICD during a rain event, preserving greater sewer capacity.

Product Construction

Constructed from durable PVC, the LMF ICD is light weight 8.9 Kg (19.7 lbs).

Product Applications

Will accommodate both square and round applications:

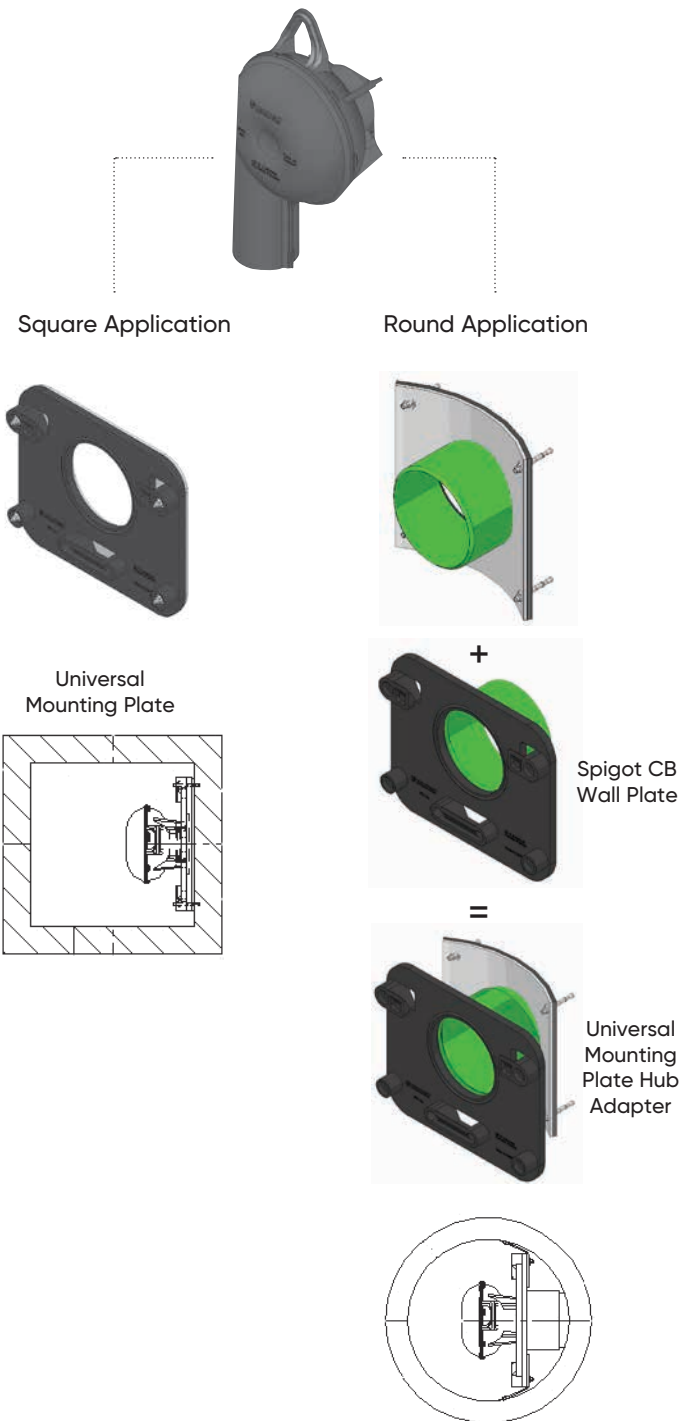

Chart 1: LMF 14 Preset Flow Curves

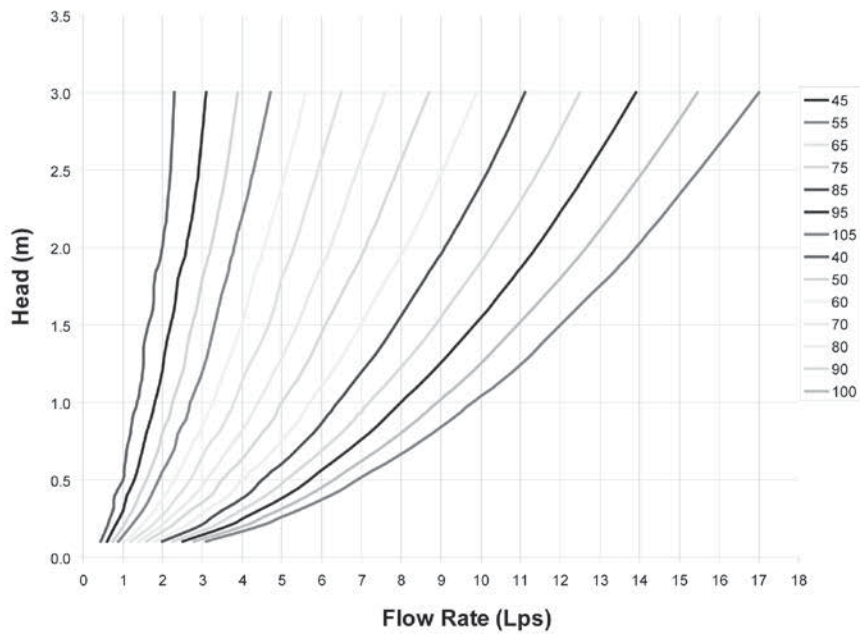
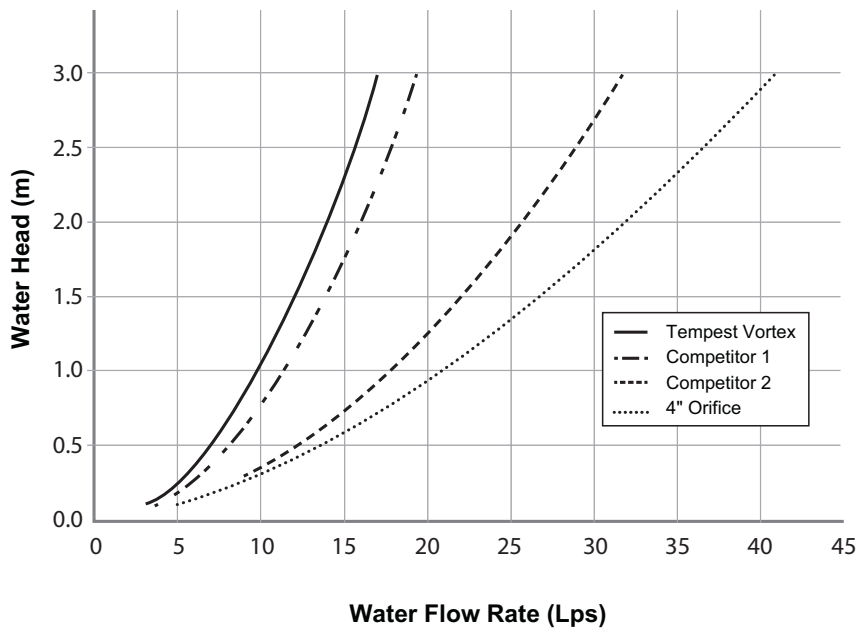

Chart 2: LMF Flow vs. ICD Alternatives



PRODUCT INSTALLATION

Instructions to assemble a TEMPEST LMF ICD into a Square Catch Basin:

STEPS:

1. Materials and tooling verification:
 - Tooling: impact drill, 3/8" concrete bit, torque wrench for 9/16" nut, hand hammer, level, and marker.
 - Material: (4) concrete anchor 3/8 x 3-1/2, (4) washers, (4) nuts, universal mounting plate, ICD device.
2. Use the mounting wall plate to locate and mark the hole (4) pattern on the catch basin wall. You should use a level to ensure that the plate is at the horizontal.
3. Use an impact drill with a 3/8" concrete bit to make the four holes at a minimum of 1-1/2" depth up to 2-1/2". Clean the concrete dust from the holes.
4. Install the anchors (4) in the holes by using a hammer. Thread the nuts on the top of the anchors to protect the threads when you hit the anchors with the hammer. Remove the nuts from the ends of the anchors.
5. Install the universal mounting plate on the anchors and screw the 4 nuts in place with a maximum torque of 40 N.m (30 lbf-ft). There should be no gap between the wall mounting plate and the catch basin wall.
6. From the ground above using a reach bar, lower the ICD device by hooking the end of the reach bar to the handle of the ICD device. Align the triangular plate portion into the mounting wall plate. Push down the device to be sure it has centered in to the universal mounting plate and has created a seal.



WARNING

- Verify that the outlet pipe doesn't protrude into the catch basin. If it does, cut down the pipe flush to the catch basin wall.
- Call your IPEX representative for more information or if you have any questions about our products.

Instructions to assemble a TEMPEST LMF ICD into a Round Catch Basin:

STEPS:

1. Materials and tooling verification.
 - Tooling: impact drill, 3/8" concrete bit, torque wrench for 9/16" nut, hand hammer, level and marker.
 - Material: (4) concrete anchor 3/8 x 3-1/2, (4) washers and (4) nuts, spigot CB wall plate, universal mounting plate hub adapter, ICD device.
2. Use the spigot catch basin wall plate to locate and mark the hole (4) pattern on the catch basin wall. You should use a level to ensure that the plate is at the horizontal.
3. Use an impact drill with a 3/8" concrete bit to make the four holes at a depth between 1-1/2" to 2-1/2". Clean the concrete dust from the holes.
4. Install the anchors (4) in the holes by using a hammer. Thread the nuts on the top of the anchors to protect the threads when you hit the anchors with the hammer. Remove the nuts from the ends of the anchors.
5. Install the CB spigot wall plate on the anchors and screw the 4 nuts in place with a maximum torque of 40 N.m (30 lbf-ft). There should be no gap between the spigot wall plate and the catch basin wall.
6. Apply solvent cement on the hub of the universal mounting plate, hub adapter and the spigot of the CB wall plate, then slide the hub over the spigot. Make sure the universal mounting plate is at the horizontal and its hub is completely inserted onto the spigot. Normally, the corners of the universal mounting plate hub adapter should touch the catch basin wall.
7. From ground above using a reach bar, lower the ICD device by hooking the end of the reach bar to the handle of the ICD device. Align the triangular plate portion into the mounting wall plate. Push down the device to be sure it has centered in to the mounting plate and has created a seal.



WARNING

- Verify that the outlet pipe doesn't protrude into the catch basin. If it does, cut back the pipe flush to the catch basin wall.
- The solvent cement which is used in this installation is to be approved for PVC.
- The solvent cement should not be used below 0°C (32°F) or in a high humidity environment. Refer to the IPEX solvent cement guide to confirm the required curing time or visit the IPEX Online Solvent Cement Training Course available at ipexna.com.
- Call your IPEX representative for more information or if you have any questions about our products.

PRODUCT TECHNICAL SPECIFICATION

General

Inlet control devices (ICD's) are designed to provide flow control at a specified rate for a given water head level and also provide odour and floatable control. All ICD's will be IPEX Tempest or approved equal.

All devices shall be removable from a universal mounting plate. An operator from street level using only a T-bar with a hook will be able to retrieve the device while leaving the universal mounting plate secured to the catch basin wall face. The removal of the TEMPEST devices listed above must not require any unbolting or special manipulation or any special tools.

High Flow (HF) Sump devices will consist of a removable threaded cap which can be accessible from street level with out entry into the catchbasin (CB). The removal of the threaded cap shall not require any special tools other than the operator's hand.

ICD's shall have no moving parts.

Materials

ICD's are to be manufactured from Polyvinyl Chloride (PVC) or Polyurethane material, designed to be durable enough to withstand multiple freeze-thaw cycles and exposure to harsh elements.

The inner ring seal will be manufactured using a Buna or Nitrile material with hardness between Duro 50 and Duro 70.

The wall seal is to be comprised of a 3/8" thick Neoprene Closed Cell Sponge gasket which is attached to the back of the wall plate.

All hardware will be made from 304 stainless steel.

Dimensioning

The Low Medium Flow (LMF), High Flow (HF) and the High Flow (HF) Sump shall allow for a minimum outlet pipe diameter of 200mm with a 600mm deep Catch Basin sump.

Installation

Contractor shall be responsible for securing, supporting and connecting the ICD's to the existing influent pipe and catchbasin/manhole structure as specified and designed by the Engineer.

PRODUCT INFORMATION: TEMPEST HF & MHF ICD

Product Description

Our HF, HF Sump and MHF ICD's are designed to accommodate catch basins or manholes with sewer outlet pipes 6" in diameter or larger. Any storm sewer larger than 12" may require custom modification. However, IPEX can custom build a TEMPEST device to accommodate virtually any storm sewer size.

Available in 5 preset flow curves, these ICDs have the ability to provide constant flow rates: 9lps (143 gpm) and greater

Product Function

TEMPEST HF (High Flow): designed to manage moderate to higher flows 15 L/s (240 gpm) or greater and prevent the propagation of odour and floatables. With this device, the cross-sectional area of the device is larger than the orifice diameter and has been designed to limit head losses. The HF ICD can also be ordered without flow control when only odour and floatable control is required.



TEMPEST HF (High Flow) Sump: The height of a sewer outlet pipe in a catch basin is not always conveniently located. At times it may be located very close to the catch basin floor, not providing enough sump for one of the other TEMPEST ICDs with universal back plate to be installed. In these applications, the HF Sump is offered. The HF Sump offers the same features and benefits as the HF ICD; however, is designed to raise the outlet in a square or round catch basin structure. When installed, the HF sump is fixed in place and not easily removed. Any required service to the device is performed through a clean-out located in the top of the device which can be often accessed from ground level.



TEMPEST MHF (Medium to High Flow): The MHF plate or plug is designed to control flow rates 9 L/s (143 gpm) or greater. It is not designed to prevent the propagation of odour and floatables.



Product Construction

The HF, HF Sump and MHF ICDs are built to be light weight at a maximum weight of 6.8 Kg (14.6 lbs).

Product Applications

The HF and MHF ICD's are available to accommodate both square and round applications:



Square Application

Universal Mounting Plate

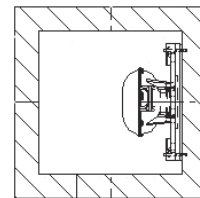

Round Application

Spigot CB Wall Plate

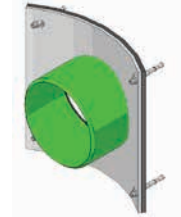

Universal Mounting Plate Hub Adapter



+

=

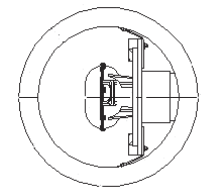

The HF Sump is available to accommodate low to no sump applications in both square and round catch basins:

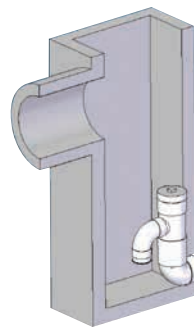

Square Catch Basin

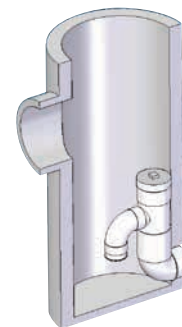

Round Catch Basin

Chart 3: HF & MHF Preset Flow Curves

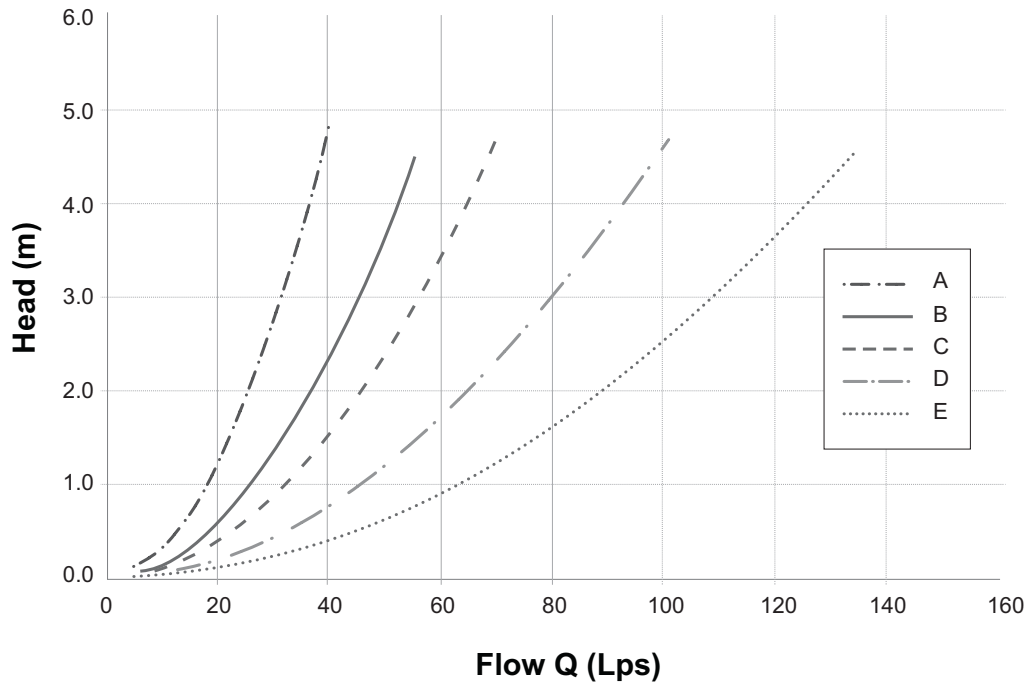

PRODUCT INSTALLATION

Instructions to assemble a TEMPEST HF or MHF ICD into a Square Catch Basin:

1. Materials and tooling verification:
 - Tooling: impact drill, 3/8" concrete bit, torque wrench for 9/16" nut, hand hammer, level, and marker.
 - Material: (4) concrete anchor 3/8 x 3-1/2, (4) washers, (4) nuts, universal mounting plate, ICD device
2. Use the mounting wall plate to locate and mark the hole (4) pattern on the catch basin wall. You should use a level to ensure that the plate is at the horizontal.
3. Use an impact drill with a 3/8" concrete bit to make the four holes at a minimum of 1-1/2" depth up to 2-1/2". Clean the concrete dust from the holes.
4. Install the anchors (4) in the holes by using a hammer. Thread the nuts on the top of the anchors to protect the threads when you hit the anchors with the hammer. Remove the nuts from the ends of the anchors.
5. Install the universal wall mounting plate on the anchors and screw the 4 nuts in place with a maximum torque of 40 N.m (30 lbf-ft). There should be no gap between the wall mounting plate and the catch basin wall.
6. From the ground above using a reach bar, lower the device by hooking the end of the reach bar to the handle of the ICD device. Align the triangular plate portion into the mounting wall plate. Push down the device to be sure it has centered in to the universal wall mounting plate and has created a seal.

WARNING

- Verify that the outlet pipe doesn't protrude into the catch basin. If it does, cut down the pipe flush to the catch basin wall.
- Call your IPEX representative for more information or if you have any questions about our products.

Instructions to assemble a TEMPEST HF or MHF ICD into a Round Catch Basin:

STEPS:

1. Materials and tooling verification.
 - Tooling: impact drill, 3/8" concrete bit, torque wrench for 9/16" nut, hand hammer, level and marker.
 - Material: (4) concrete anchor 3/8 x 3-1/2, (4) washers and (4) nuts, spigot CB wall plate, universal mounting plate hub adapter, ICD device.
2. Use the round catch basin spigot adaptor to locate and mark the hole (4) pattern on the catch basin wall. You should use a level to ensure that the plate is at the horizontal.
3. Use an impact drill with a 3/8" concrete bit to make the four holes at a depth between 1-1/2" to 2-1/2". Clean the concrete dust from the holes.
4. Install the anchors (4) in the holes by using a hammer. Thread the nuts on the top of the anchors to protect the threads when you hit the anchors with the hammer. Remove the nuts from the ends of the anchors.
5. Install the spigot CB wall plate on the anchors and screw the 4 nuts in place with a maximum torque of 40 N.m (30 lbf-ft). There should be no gap between the spigot CB wall plate and the catch basin wall.
6. Put solvent cement on the hub of the universal mounting plate, hub adapter and the spigot of the CB wall plate, then slide the hub over the spigot. Make sure the universal mounting plate is at the horizontal and its hub is completely inserted onto the spigot. Normally, the corners of the hub adapter should touch the catch basin wall.
7. From ground above using a reach bar, lower the device by hooking the end of the reach bar to the handle of the ICD device. Align the triangular plate portion into the mounting wall plate. Push down the device to be sure it has centered in to the wall mounting plate and has created a seal.

WARNING

- Verify that the outlet pipe doesn't protrude into the catch basin. If it does, cut down the pipe flush to the catch basin wall.
- The solvent cement which is used in this installation is to be approved for PVC.
- The solvent cement should not be used below 0°C (32°F) or in a high humidity environment. Refer to the IPEX solvent cement guide to confirm the required curing time or visit the IPEX Online Solvent Cement Training Course available at www.ipexinc.com.
- Call your IPEX representative for more information or if you have any questions about our products.

Instructions to assemble a TEMPEST HF Sump into a Square or Round Catch Basin:

STEPS:

1. Materials and tooling verification:
 - Tooling: impact drill, 3/8" concrete bit, torque wrench for 9/16" nut, hand hammer, level, mastic tape and metal strapping
 - Material: (2) concrete anchor 3/8 x 3-1/2, (2) washers, (2) nuts, HF Sump pieces (2).
2. Apply solvent cement to the spigot end of the top half of the sump. Apply solvent cement to the hub of the bottom half of the sump. Insert the spigot of the top half of the sump into the hub of the bottom half of the sump.
3. Install the 8" spigot of the device into the outlet pipe. Use the mastic tape to seal the device spigot into the outlet pipe. You should use a level to be sure that the fitting is standing at the vertical.
4. Use an impact drill with a 3/8" concrete bit to make a series of 2 holes along each side of the body throat. The depth of the hole should be between 1-1/2" to 2-1/2". Clean the concrete dust from the 2 holes.
5. Install the anchors (2) in the holes by using a hammer. Put the nuts on the top of the anchors to protect the threads when you hit the anchors. Remove the nuts from the ends of the anchors.
6. Cut the metal strapping to length and connect each end of the strapping to the anchors. Screw the nuts in place with a maximum torque of 40 N.m (30 lbf-ft). The device should be completely flush with the catch basin wall.



WARNING

- Verify that the outlet pipe doesn't protrude into the catch basin. If it does, cut down the pipe flush to the catch basin wall.
- The solvent cement which is used in this installation is to be approved for PVC.
- The solvent cement should not be used below 0°C (32°F) or in a high humidity environment. Refer to the IPEX solvent cement guide to confirm the required curing time or visit the IPEX Online Solvent Cement Training Course available at www.ipexinc.com.
- Call your IPEX representative for more information or if you have any questions about our products.

PRODUCT TECHNICAL SPECIFICATION

General

Inlet control devices (ICD's) are designed to provide flow control at a specified rate for a given water head level and also provide odour and floatable control where specified. All ICD's will be IPEX Tempest or approved equal.

All devices shall be removable from a universal mounting plate. An operator from street level using only a T-bar with a hook shall be able to retrieve the device while leaving the universal mounting plate secured to the catch basin wall face. The removal of the TEMPEST devices listed above shall not require any unbolting or special manipulation or any special tools.

High Flow (HF) Sump devices shall consist of a removable threaded cap which can be accessible from street level with out entry into the catchbasin (CB). The removal of the threaded cap shall not require any special tools other than the operator's hand.

ICD's shall have no moving parts.

Materials

ICD's are to be manufactured from Polyvinyl Chloride (PVC) or Polyurethane material, designed to be durable enough to withstand multiple freeze-thaw cycles and exposure to harsh elements.

The inner ring seal will be manufactured using a Buna or Nitrile material with hardness between Duro 50 and Duro 70.

The wall seal is to be comprised of a 3/8" thick Neoprene Closed Cell Sponge gasket which is attached to the back of the wall plate.

All hardware will be made from 304 stainless steel.

Dimensioning

The Low Medium Flow (LMF), High Flow (HF) and the High Flow (HF) Sump shall allow for a minimum outlet pipe diameter of 200mm with a 600mm deep Catch Basin sump.

Installation

Contractor shall be responsible for securing, supporting and connecting the ICD's to the existing influent pipe and catchbasin/manhole structure as specified and designed by the Engineer.

NOTES

SALES AND CUSTOMER SERVICE

IPEX USA LLC

Toll Free: (800) 463-9572

ipexna.com

About the IPEX Group of Companies

As leading suppliers of thermoplastic piping systems, the IPEX Group of Companies provides our customers with some of the largest and most comprehensive product lines. All IPEX products are backed by more than 50 years of experience. With state-of-the-art manufacturing facilities and distribution centers across North America, we have established a reputation for product innovation, quality, end-user focus and performance.

Markets served by IPEX group products are:

- Electrical systems
- Telecommunications and utility piping systems
- PVC, CPVC, PP, ABS, PEX, FR-PVDF and PE pipe and fittings (1/4" to 48")
- Industrial process piping systems
- Municipal pressure and gravity piping systems
- Plumbing and mechanical piping systems
- PE Electrofusion systems for gas and water
- Industrial, plumbing and electrical cements
- Irrigation systems

Products manufactured by IPEX Inc. and distributed in the United States by IPEX USA LLC.

Tempest™ is a trademark of IPEX Branding Inc.

This literature is published in good faith and is believed to be reliable. However it does not represent and/or warrant in any manner the information and suggestions contained in this brochure. Data presented is the result of laboratory tests and field experience.

A policy of ongoing product improvement is maintained. This may result in modifications of features and/or specifications without notice.



**APPENDIX H
CITY OF OTTAWA DESIGN CHECKLIST**

City of Ottawa

4. Development Servicing Study Checklist

The following section describes the checklist of the required content of servicing studies. It is expected that the proponent will address each one of the following items for the study to be deemed complete and ready for review by City of Ottawa Infrastructure Approvals staff.

The level of required detail in the Servicing Study will increase depending on the type of application. For example, for Official Plan amendments and re-zoning applications, the main issues will be to determine the capacity requirements for the proposed change in land use and confirm this against the existing capacity constraint, and to define the solutions, phasing of works and the financing of works to address the capacity constraint. For subdivisions and site plans, the above will be required with additional detailed information supporting the servicing within the development boundary.

4.1 General Content

Criteria	Location (if applicable)
<input type="checkbox"/> Executive Summary (for larger reports only).	N/A
<input type="checkbox"/> Date and revision number of the report.	On Cover
<input type="checkbox"/> Location map and plan showing municipal address, boundary, and layout of proposed development.	Appendix A
<input type="checkbox"/> Plan showing the site and location of all existing services.	Site Servicing Plan (C102)
<input type="checkbox"/> Development statistics, land use, density, adherence to zoning and official plan, and reference to applicable subwatershed and watershed plans that provide context to which individual developments must adhere.	1.1 Purpose 1.2 Site Description 6.0 Stormwater Management
<input type="checkbox"/> Summary of pre-consultation meetings with City and other approval agencies.	Appendix B
<input type="checkbox"/> Reference and confirm conformance to higher level studies and reports (Master Servicing Studies, Environmental Assessments, Community Design Plans), or in the case where it is not in conformance, the proponent must provide justification and develop a defensible design criteria.	1.1 Purpose 1.2 Site Description 6.0 Stormwater Management
<input type="checkbox"/> Statement of objectives and servicing criteria.	3.0 Pre-Consultation Summary

<input type="checkbox"/> Identification of existing and proposed infrastructure available in the immediate area.	N/A
<input type="checkbox"/> Identification of Environmentally Significant Areas, watercourses and Municipal Drains potentially impacted by the proposed development (Reference can be made to the Natural Heritage Studies, if available).	Site Grading Plan (C101)
<input type="checkbox"/> Concept level master grading plan to confirm existing and proposed grades in the development. This is required to confirm the feasibility of proposed stormwater management and drainage, soil removal and fill constraints, and potential impacts to neighbouring properties. This is also required to confirm that the proposed grading will not impede existing major system flow paths.	N/A
<input type="checkbox"/> Identification of potential impacts of proposed piped services on private services (such as wells and septic fields on adjacent lands) and mitigation required to address potential impacts.	N/A
<input type="checkbox"/> Proposed phasing of the development, if applicable.	N/A
<input type="checkbox"/> Reference to geotechnical studies and recommendations concerning servicing.	Section 2.0 Background Studies, Standards and References
<input type="checkbox"/> All preliminary and formal site plan submissions should have the following information: <ul style="list-style-type: none"> ○ Metric scale ○ North arrow (including construction North) ○ Key plan ○ Name and contact information of applicant and property owner ○ Property limits including bearings and dimensions ○ Existing and proposed structures and parking areas ○ Easements, road widening and rights-of-way ○ Adjacent street names 	Site Grading Plan (C101)

4.2 Development Servicing Report: Water

Criteria	Location (if applicable)
<input type="checkbox"/> Confirm consistency with Master Servicing Study, if available	N/A
<input type="checkbox"/> Availability of public infrastructure to service proposed development	N/A
<input type="checkbox"/> Identification of system constraints	N/A
<input type="checkbox"/> Identify boundary conditions	Appendix C
<input type="checkbox"/> Confirmation of adequate domestic supply and pressure	N/A
<input type="checkbox"/> Confirmation of adequate fire flow protection and confirmation that fire flow is calculated as per the Fire Underwriter’s Survey. Output should show available fire flow at locations throughout the development.	Appendix C
<input type="checkbox"/> Provide a check of high pressures. If pressure is found to be high, an assessment is required to confirm the application of pressure reducing valves.	N/A
<input type="checkbox"/> Definition of phasing constraints. Hydraulic modeling is required to confirm servicing for all defined phases of the project including the ultimate design	N/A
<input type="checkbox"/> Address reliability requirements such as appropriate location of shut-off valves	N/A
<input type="checkbox"/> Check on the necessity of a pressure zone boundary modification.	N/A
<input type="checkbox"/> Reference to water supply analysis to show that major infrastructure is capable of delivering sufficient water for the proposed land use. This includes data that shows that the expected demands under average day, peak hour and fire flow conditions provide water within the required pressure range	Appendix C, Section 4.2

<input type="checkbox"/> Description of the proposed water distribution network, including locations of proposed connections to the existing system, provisions for necessary looping, and appurtenances (valves, pressure reducing valves, valve chambers, and fire hydrants) including special metering provisions.	Site Servicing Plan (C101)
<input type="checkbox"/> Description of off-site required feeder mains, booster pumping stations, and other water infrastructure that will be ultimately required to service proposed development, including financing, interim facilities, and timing of implementation.	N/A
<input type="checkbox"/> Confirmation that water demands are calculated based on the City of Ottawa Design Guidelines.	Appendix C
<input type="checkbox"/> Provision of a model schematic showing the boundary conditions locations, streets, parcels, and building locations for reference.	N/A

4.3 Development Servicing Report: Wastewater

Criteria	Location (if applicable)
<input type="checkbox"/> Summary of proposed design criteria (Note: Wet-weather flow criteria should not deviate from the City of Ottawa Sewer Design Guidelines. Monitored flow data from relatively new infrastructure cannot be used to justify capacity requirements for proposed infrastructure).	N/A
<input type="checkbox"/> Confirm consistency with Master Servicing Study and/or justifications for deviations.	N/A
<input type="checkbox"/> Consideration of local conditions that may contribute to extraneous flows that are higher than the recommended flows in the guidelines. This includes groundwater and soil conditions, and age and condition of sewers.	N/A
<input type="checkbox"/> Description of existing sanitary sewer available for discharge of wastewater from proposed development.	Section 5.1 Existing Sanitary Sewer

<input type="checkbox"/> Verify available capacity in downstream sanitary sewer and/or identification of upgrades necessary to service the proposed development. (Reference can be made to previously completed Master Servicing Study if applicable)	N/A
<input type="checkbox"/> Calculations related to dry-weather and wet-weather flow rates from the development in standard MOE sanitary sewer design table (Appendix 'C') format.	N/A
<input type="checkbox"/> Description of proposed sewer network including sewers, pumping stations, and forcemains.	Section 5.2 Proposed Sanitary Sewer
<input type="checkbox"/> Discussion of previously identified environmental constraints and impact on servicing (environmental constraints are related to limitations imposed on the development in order to preserve the physical condition of watercourses, vegetation, soil cover, as well as protecting against water quantity and quality).	N/A
<input type="checkbox"/> Pumping stations: impacts of proposed development on existing pumping stations or requirements for new pumping station to service development.	N/A
<input type="checkbox"/> Forcemain capacity in terms of operational redundancy, surge pressure and maximum flow velocity.	N/A
<input type="checkbox"/> Identification and implementation of the emergency overflow from sanitary pumping stations in relation to the hydraulic grade line to protect against basement flooding.	N/A
<input type="checkbox"/> Special considerations such as contamination, corrosive environment etc.	N/A

4.4 Development Servicing Report: Stormwater Checklist

Criteria	Location (if applicable)
<input type="checkbox"/> Description of drainage outlets and downstream constraints including legality of outlets (i.e. municipal drain, right-of-way, watercourse, or private property)	Section 6.0 Stormwater Sewer Design & Section 7.0 Proposed Stormwater Management
<input type="checkbox"/> Analysis of available capacity in existing public infrastructure.	N/A
<input type="checkbox"/> A drawing showing the subject lands, its surroundings, the receiving watercourse, existing drainage patterns, and proposed drainage pattern.	Pre & Post-Development Plans
<input type="checkbox"/> Water quantity control objective (e.g. controlling post-development peak flows to pre-development level for storm events ranging from the 2 or 5-year event (dependent on the receiving sewer design) to 100-year return period); if other objectives are being applied, a rationale must be included with reference to hydrologic analyses of the potentially affected subwatersheds, taking into account long-term cumulative effects.	Section 6.0 Stormwater Sewer Design & Section 7.0 Proposed Stormwater Management
<input type="checkbox"/> Water Quality control objective (basic, normal or enhanced level of protection based on the sensitivities of the receiving watercourse) and storage requirements.	Section 6.0 Stormwater Sewer Design & Section 7.0 Proposed Stormwater Management
<input type="checkbox"/> Description of the stormwater management concept with facility locations and descriptions with references and supporting information.	Section 6.0 Stormwater Sewer Design & Section 7.0 Proposed Stormwater Management
<input type="checkbox"/> Set-back from private sewage disposal systems.	N/A
<input type="checkbox"/> Watercourse and hazard lands setbacks.	N/A
<input type="checkbox"/> Record of pre-consultation with the Ontario Ministry of Environment and the Conservation Authority that has jurisdiction on the affected watershed.	N/A
<input type="checkbox"/> Confirm consistency with sub-watershed and Master Servicing Study, if applicable study exists.	N/A
<input type="checkbox"/> Storage requirements (complete with calculations) and conveyance capacity for minor events (1:5-year return period) and major events (1:100-year return period).	Appendix G

<input type="checkbox"/> Identification of watercourses within the proposed development and how watercourses will be protected, or, if necessary, altered by the proposed development with applicable approvals.	Site Grading Plan
<input type="checkbox"/> Calculate pre-and post development peak flow rates including a description of existing site conditions and proposed impervious areas and drainage catchments in comparison to existing conditions.	Section 7.0 Proposed Stormwater Management Appendix G
<input type="checkbox"/> Any proposed diversion of drainage catchment areas from one outlet to another.	Section 6.0 Stormwater Sewer Design & Section 7.0 Proposed Stormwater Management
<input type="checkbox"/> Proposed minor and major systems including locations and sizes of stormwater trunk sewers, and stormwater management facilities.	Section 6.0 Stormwater Sewer Design & Section 7.0 Proposed Stormwater Management
<input type="checkbox"/> If quantity control is not proposed, demonstration that downstream system has adequate capacity for the post-development flows up to and including the 100-year return period storm event.	N/A
<input type="checkbox"/> Identification of potential impacts to receiving watercourses	N/A
<input type="checkbox"/> Identification of municipal drains and related approval requirements.	N/A
<input type="checkbox"/> Descriptions of how the conveyance and storage capacity will be achieved for the development.	Section 6.0 Stormwater Sewer Design & Section 7.0 Proposed Stormwater Management
<input type="checkbox"/> 100-year flood levels and major flow routing to protect proposed development from flooding for establishing minimum building elevations (MBE) and overall grading.	Site Grading Plan (C101)
<input type="checkbox"/> Inclusion of hydraulic analysis including hydraulic grade line elevations.	N/A

<input type="checkbox"/> Description of approach to erosion and sediment control during construction for the protection of receiving watercourse or drainage corridors.	Section 8.0 Sediment & Erosion Control
<input type="checkbox"/> Identification of floodplains – proponent to obtain relevant floodplain information from the appropriate Conservation Authority. The proponent may be required to delineate floodplain elevations to the satisfaction of the Conservation Authority if such information is not available or if information does not match current conditions.	N/A
<input type="checkbox"/> Identification of fill constraints related to floodplain and geotechnical investigation.	N/A

4.5 Approval and Permit Requirements: Checklist

The Servicing Study shall provide a list of applicable permits and regulatory approvals necessary for the proposed development as well as the relevant issues affecting each approval. The approval and permitting shall include but not be limited to the following:

Criteria	Location (if applicable)
<input type="checkbox"/> Conservation Authority as the designated approval agency for modification of floodplain, potential impact on fish habitat, proposed works in or adjacent to a watercourse, cut/fill permits and Approval under Lakes and Rivers Improvement Act. The Conservation Authority is not the approval authority for the Lakes and Rivers Improvement Act. Where there are Conservation Authority regulations in place, approval under the Lakes and Rivers Improvement Act is not required, except in cases of dams as defined in the Act.	N/A
<input type="checkbox"/> Application for Certificate of Approval (CofA) under the Ontario Water Resources Act.	N/A
<input type="checkbox"/> Changes to Municipal Drains.	N/A
<input type="checkbox"/> Other permits (National Capital Commission, Parks Canada, Public Works and Government Services Canada, Ministry of Transportation etc.)	N/A

4.6 Conclusion Checklist

Criteria	Location (if applicable)
<input type="checkbox"/> Clearly stated conclusions and recommendations	Section 9.0 Summary Section 10.0 Recommendations
<input type="checkbox"/> Comments received from review agencies including the City of Ottawa and information on how the comments were addressed. Final sign-off from the responsible reviewing agency.	All are stamped
<input type="checkbox"/> All draft and final reports shall be signed and stamped by a professional Engineer registered in Ontario	All are stamped