

# 951 Gladstone Avenue and 145 Loretta Avenue North Transportation Impact Assessment

Step 1 Screening Report

Step 2 Scoping Report

Step 3 Forecasting Report

Step 4 Strategy Report (revision #3)

Prepared for:

TIP Gladstone Limited Partnership  
200-485 Bank Street  
Ottawa, ON K2P 1Z2

Prepared by:



6 Plaza Court  
Ottawa, ON K2H 7W1

October 2022

PN: 2020-25

## Table of Contents

1	Screening .....	1
2	Existing and Planned Conditions .....	1
2.1	Proposed Development.....	1
2.2	Existing Conditions .....	4
2.2.1	Area Road Network .....	4
2.2.2	Existing Intersections.....	4
2.2.3	Existing Driveways .....	5
2.2.4	Cycling and Pedestrian Facilities.....	5
2.2.5	Existing Transit.....	7
2.2.6	Existing Area Traffic Management Measures.....	8
2.2.7	Existing Peak Hour Travel Demand.....	8
2.2.8	Collision Analysis .....	10
2.3	Planned Conditions.....	13
2.3.1	Changes to the Area Transportation Network .....	13
2.3.2	Other Study Area Developments.....	14
3	Study Area and Time Periods .....	15
3.1	Study Area .....	15
3.2	Time Periods .....	15
3.3	Horizon Years.....	15
4	Exemption Review .....	15
5	Development-Generated Travel Demand .....	16
5.1	Mode Shares.....	16
5.2	Trip Generation .....	16
5.3	Trip Distribution.....	18
5.4	Trip Assignment.....	18
6	Background Network Travel Demands.....	19
6.1	Transportation Network Plans .....	19
6.2	Background Growth.....	19
6.3	Other Developments .....	19
7	Demand Rationalization .....	20
7.1	Modal Share Sensitivity .....	20
8	Development Design .....	20
8.1	Design for Sustainable Modes.....	20
8.2	Circulation and Access.....	20
9	Parking.....	20
9.1	Parking Supply .....	20
10	Boundary Street Design.....	21
11	Access Intersections Design .....	21
11.1	Location and Design of Access.....	21
11.2	Intersection Control.....	21
11.3	Access Intersection Design .....	21
11.3.1	Future Total Access Intersection Operations .....	21

11.3.2	Access Intersection MMLOS .....	22
11.3.3	Recommended Design Elements .....	23
12	Transportation Demand Management .....	23
12.1	Context for TDM .....	23
12.2	Need and Opportunity.....	23
12.3	TDM Program .....	23
13	Neighbourhood Traffic Management.....	23
14	Transit.....	24
14.1	Route Capacity.....	24
14.2	Transit Priority .....	24
15	Network Intersection Design.....	24
15.1	Network Intersection Control.....	24
15.2	Network Intersection Design.....	25
15.2.1	Future Total Network Intersection Operations .....	25
15.2.2	Network Intersection MMLOS.....	26
15.2.3	Recommended Design Elements.....	26
16	Summary of Improvements Indicated and Modifications Options.....	26
17	Conclusion .....	29

## List of Figures

Figure 1: Area Context Plan .....	2
Figure 2: Concept Plan.....	3
Figure 3: Study Area Pedestrian Facilities .....	5
Figure 4: Study Area Cycling Facilities .....	6
Figure 5: Existing Pedestrian Volumes .....	6
Figure 6: Existing Cycling Volumes .....	7
Figure 7: Existing Study Area Transit Service.....	8
Figure 8: Existing Study Area Transit Stops .....	8
Figure 9: Existing Traffic Counts .....	9
Figure 10: Study Area Collision Records – Representation of 2015-2019.....	11
Figure 11: Gladstone Station District CDP Vision & Concept Options Report – Preferred Option: Perspective Looking North-East .....	14
Figure 12: New Site Generation Auto Volumes.....	19
Figure 13: Future Total Volumes .....	22

## Table of Tables

Table 1: Intersection Count Date.....	8
Table 2: Existing Intersection Operations.....	9
Table 3: Study Area Collision Summary, 2015-2019 .....	10
Table 4: Summary of Collision Locations, 2015-2019 .....	11
Table 5: Gladstone Avenue and Bayswater Avenue Collision Summary.....	12
Table 6: Gladstone Avenue and Preston Street Collision Summary.....	12

Table 7: Somerset Street W between Breezehill Avenue and Preston Street Collision Summary .....	13
Table 8: Exemption Review .....	15
Table 9: TRANS Trip Generation Manual Recommended Mode Shares – Ottawa West .....	16
Table 10: Proposed Development Mode Shares .....	16
Table 11: Trip Generation Person Trip Rates by Peak Period.....	17
Table 12: Total Residential Person Trip Generation by Peak Period.....	17
Table 13: Internal Capture Rates.....	17
Table 14: Residential Trip Generation by Mode.....	17
Table 15: OD Survey Distribution .....	18
Table 16: Proposed Parking Ratios .....	20
Table 17: Boundary Street MMLOS Analysis .....	21
Table 18: Future Total Access Intersection Operations .....	22
Table 19: Trip Generation by Transit Mode .....	24
Table 20: Future Total Network Intersection Operations .....	25
Table 21: Study Area Intersection MMLOS Analysis .....	26

## List of Appendices

- Appendix A – TIA Screening Form and Certification Form
- Appendix B – Turning Movement Count Data
- Appendix C – Synchro Intersection Worksheets – Existing Conditions
- Appendix D – Collision Data
- Appendix E – MMLOS Analysis
- Appendix F – Synchro Intersection Worksheets – Future Total Conditions
- Appendix G – TDM Checklist
- Appendix H – Signal Warrant – OTM Justification 7

## 1 Screening

This study has been prepared according to the City of Ottawa's 2017 Transportation Impact Assessment (TIA) Guidelines. A TIA report was submitted and approved for the zoning bylaw amendment in 2019. This report provides an update on the existing conditions, forecasting and network impact component and the submission of the design review component. Accordingly, the Step 1 Screening Form has been revised and is included as Appendix A, along with the Certification Form for TIA Study PM. This TIA will support the site plan application.

## 2 Existing and Planned Conditions

### 2.1 Proposed Development

The proposed development is located at 951 Gladstone Avenue and 145 Loretta Avenue North and has undergone an Official Plan and Zoning amendment to rezone the site from general industry (IG) zoning to mixed-use centre (MC). The existing land uses have been closed and previously included a brewery, jujitsu club, cross-fit gym, glass blowing, art studio, beer and wine supply, bread bakery, and other assorted industrial uses. The proposed site plan application consists of approximately 849 residential units, 193,015 sq. ft of office space (including the existing Standard Bread building, live-work space) and 17,611 sq. ft of retail space. A total of 560 parking spaces will be provided (30 are visitor spaces), with four at ground level and the remaining 556 in the two levels of underground parking. Parking spaces for bikes are provided in the underground parking levels totalling 503 spaces. The existing accesses will be removed from both properties with a new two-way general access between Towers 1 and 2, with a one-way loop extending past Tower 2 and 3 to Loretta Avenue North. A loading/move-in areas will be provided adjacent to the underground parking ramp, and an additional loading/move-in access will be provided north of the one-way general access loop. The frontage along Loretta Avenue North would formalize the curb edge and remove the paved shoulder and open access along the building frontage. The anticipated full build-out and occupancy horizon is 2026. Figure 1 illustrates the Study Area Context. Figure 2 illustrates the proposed concept plan.

Figure 1: Area Context Plan



Source: <http://maps.ottawa.ca/geoOttawa/> Accessed: March 21, 2021

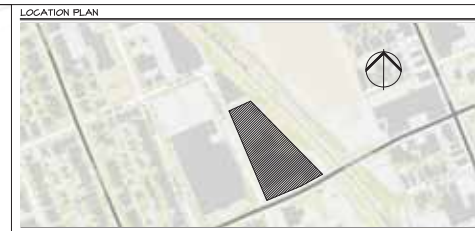
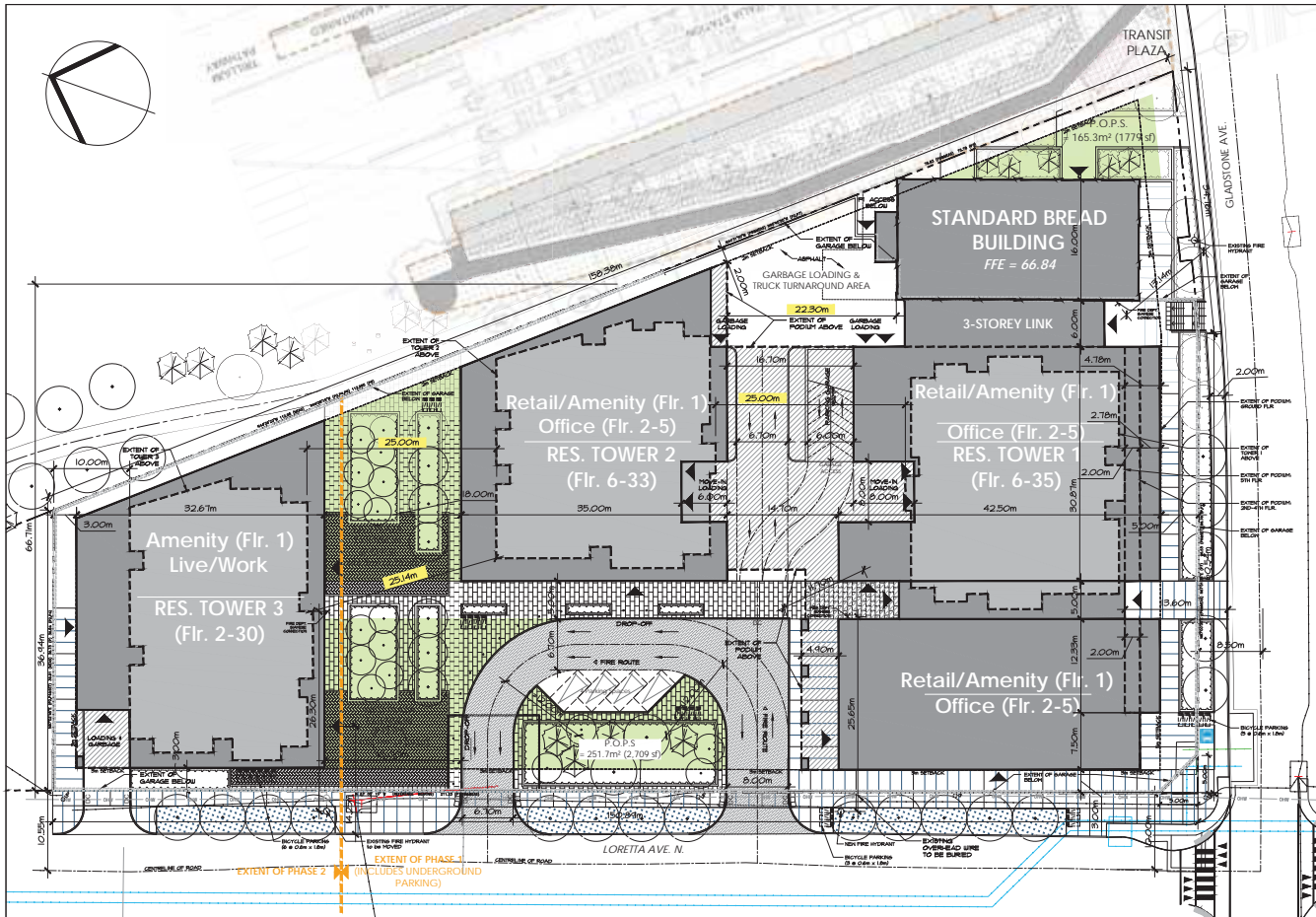

**SURVEY INFORMATION TAKEN FROM:**  
 SURVEYOR'S REAL PROPERTY REPORT  
 PART 1 - PLAN OF

**LEGEND**

BUS STOP	
EXISTING OVERHEAD WIRING (TO BE REMOVED)	
FIRE HYDRANT (EXISTING & NEW - as noted)	
EXISTING UTILITY POLE (TO BE REMOVED)	
PROPERTY LINE	
SETBACK LINE	
FIRE ROUTE	
PRIVATELY OWNED PUBLIC SPACE (P.O.P.S.)	
EXTENT OF GARAGE BELOW	

PART OF LOT 1 & LOTS 2 & 3 (WEST CHAMPAGNE AVENUE) BLOCK C AND LOTS 1, 2 & 3 (EAST LORETTA AVENUE) LOTS 4, 5, 6, 7 & 8 BLOCK C AND PART OF BLOCK C AND PART OF CHAMPAGNE STREET (CLOSED BY BY-LAW 4863)

REGISTERED PLAN T3  
 CITY OF OTTAWA

STANTEC GEOMATICS LTD, 2017

**Gladstone and Loretta Mixed-Use Hub  
 Draft Zoning Table**

MO[XXXX] YYYY-A	Requirement	Proposed
Minimum Lot Width (m)	No minimum	Complies
Minimum Lot Area (m <sup>2</sup> )	No minimum	Complies
Minimum Front Yard Setback (m)	5 metres, aside from Standard Bread Building (See S.YYY)	5m
Minimum Rear Yard Setback (m)	3 metres (See S.YYY)	3m
Interior Side Yard Setback (m)	2 metres, aside from Standard Bread Building (See S.YYY)	2m
Corner Side Yard Setback (m)	3 metres (See S.YYY)	3m
Minimum Building Height (m)	6.7m (See S.YYY)	Complies
Maximum Building Height (m)	0m to 132m (See S.YYY)	Complies
Maximum Floor Space Index	No maximum	N/A
Minimum Width of Landscaped Area	No minimum, except that where a yard is provided and not used for required driveways, alleys, parking, loading spaces or outdoor commercial patio, the whole yard must be landscaped	Complies
Minimum Tower Separation Distance	23 metres	Complies
Minimum Tower Podium Stepback Distance	2 metres	2m at Gladstone frontage only

Parking Requirements (Sec. 101, 102, 106, 111)	Requirement	Proposed
Area 2 of Schedule 1A	0 spaces/unit (residential) 0.1 spaces/unit, see first 12 units (visitor), but no more than 30	Surface: 4 P1: 271 P2: 273 Total: 548
Vehicle Space Dimensions	Must be 2.6m-3.1m by 5.2m Up to 40% of required parking aside from visitors spaces may be 2.4m x 4.6m	Complies
Bicycle Parking Bike Storage Office Retail Studio 1 space per 250m <sup>2</sup> GFA	0.5 x #all units = 424.5 bicycles 10 566 / 250 = 78.3 bicycles Total bicycle spaces: 503.8	503 spaces proposed

Bicycle Space Dimensions	Requirement	Proposed
Horizontal: 0.6m by 1.6m Vertical: 0.5m by 1.5m (max 50% of required spaces) Stacked: 0.37m by 1.5m	Complies	Complies
Drive Aisle Width (Double Traffic Lane)	Parking Lot: Minimum: 6.7m Parking Garage: Minimum: 6m Maximum: 6.7m	Complies
Amenity Space Requirements (Sec. 117)	Requirement	Proposed
Total: 6m <sup>2</sup> per unit Communal: 50% of total required	Total: 5,076 m <sup>2</sup> Communal: 2,538 m <sup>2</sup>	Rooftop Terrace (Communal): 1,441.5m <sup>2</sup> Indoor Amenity (Communal): 1,207.5m <sup>2</sup> Balconies: ~3,548.2m <sup>2</sup> POPS: 1,269.4m <sup>2</sup>



**PROJECT CONSULTANTS:**

- Owner / Applicant**  
 CLV GROUP  
 485 Bank Street, Suite 200  
 Ottawa, ON, K2P 1Z2
- PRC GROUP**  
 205-485 Bank Street  
 Ottawa, ON, K2P 1Z2
- Architect**  
 Hobin Architecture Inc.  
 63 Pamela Street  
 Ottawa, ON K1S 3K7
- Planning**  
 Futeren Planning & Design  
 360 Cooper Street, Suite 300  
 Ottawa, ON K2P 2H7
- Landscape**  
 CSW Landscape Architects Limited  
 319 McEwen Ave.  
 Ottawa, ON K1Z 0B9
- CIVIL**  
 WSP |  
 150 Slater Street  
 Ottawa, ON K1P 5M8
- Surveyor**  
 Stantec Geomatics Ltd.  
 400-1331 Clyde Ave.  
 Ottawa, ON K2C 3C4
- Geotechnical**  
 Patterson Group Inc.  
 154 Colonsdale Road South  
 Ottawa, ON K2E 7J5
- Transportation**  
 CGH Transportation Inc.  
 13 Markham Ave.  
 Ottawa, ON K2C 3Z1
- Heritage**  
 Commonwealth Historic Resource Management  
 53 Herriot Street  
 Perth, ON, K7H 1T5



NO.	DATE	REVISION
05	OCT. 10, 2022	SITE PLAN COMMENTS
04	MAR. 02, 2022	SITE PLAN COMMENTS
03	APR. 02, 2021	SITE PLAN
02	FEB. 12, 2020	ZONING & OPA
01	DEC. 04, 2019	CITY COMMENTS

It is the responsibility of the appropriate contractor to check and verify all dimensions on site and report all errors and/or omissions to the architect.

All contractors must comply with all pertinent codes and by-laws.

Do not scale drawings.

This drawing may not be used for construction unless signed.

Copyright reserved.



**PROJECT LOCATION:**  
 951 GLADSTONE AVE.  
 & 145 LORETTA AVE. NORTH

**DRAWING TITLE:**  
 SITE PLAN

**DRAWN BY:** TR  
**DATE:** 11/20/2022  
**SCALE:** 1:50  
**PROJECT:** 105  
**DRAWING NO.:** S1



007-12-21-0053

## 2.2 Existing Conditions

### 2.2.1 Area Road Network

*Preston Street:* Preston Street is a City of Ottawa arterial road with a two-lane urban cross-section, including parking lanes and auxiliary lanes at major intersections. The unposted speed limit is 50 km/h, and the Ottawa Official Plan reserves a 23.0 metre right-of-way.

*Somerset Street West:* Somerset Street West is a City of Ottawa arterial road with a two-lane cross-section, including sidewalks and on street parking. The unposted speed limit is 50 km/h, and the right-of-way is 20.0 metres. East of Breezehill Avenue, bike lanes are provided.

*Gladstone Avenue:* Gladstone Avenue is a City of Ottawa major collector road with a two-lane urban cross-section including sidewalks and a posted speed limit of 40 km/h. The current right-of-way is 20.0 metres, with additional width provided in proximity to the rail corridor.

*Bayswater Avenue:* Bayswater Avenue is a City of Ottawa collector road with a two-lane urban cross-section, including sidewalks and on-street parking. The posted speed limit is 30 km/h, and the right-of-way is 25.0 metres.

*Loretta Avenue North/Laurel Street:* Loretta Avenue N is a City of Ottawa local road with a two-lane urban cross-section including paved shoulders on the east side and a sidewalk on the west side. The posted speed is 40 km/h, and the right-of-way is 20.0 metres.

*Breezehill Avenue:* Breezehill Avenue is a City of Ottawa local road with a two-lane urban cross-section, including sidewalks, and parking on the east side of the road. The posted speed limit is 40 km/h, and the right-of-way is 20.0 metres.

### 2.2.2 Existing Intersections

The existing signalized area intersections within one kilometre of the site have been summarized below:

<i>Gladstone Avenue &amp; Bayswater Avenue</i>	The intersection of Gladstone Avenue and Bayswater Avenue is a signalized intersection with shared all movement lanes on each approach. No turn restrictions were noted.
<i>Gladstone Avenue &amp; Preston Street</i>	The intersection of Gladstone Avenue and Preston Street is a signalized intersection with auxiliary left-turn lanes on the northbound, westbound, and southbound approaches. Eastbound and southbound right turns on red are prohibited.
<i>Somerset Street West &amp; Breezehill Avenue</i>	The intersection of Somerset Street West and Breezehill Avenue is a minor stop-controlled intersection with shared movement lanes on all approaches. Bike lanes along Somerset Street West start/end on the east side of the intersection. No turn restrictions were noted.
<i>Gladstone Avenue &amp; Loretta Avenue North</i>	The intersection of Gladstone Avenue and Loretta Avenue N is a minor stop-controlled intersection with shared movement lanes on all approaches. No turn restrictions were noted.

*Laurel Street & Breezehill Avenue*

The intersection of Laurel Street and Breezehill Avenue is an all-way stop-controlled intersection with shared movement lanes on all approaches. No turn restrictions were noted.

2.2.3 Existing Driveways

Along Gladstone Avenue, a driveway to the City of Ottawa yard (175 Loretta Avenue North) is located opposite the existing Standard Bread access adjacent to the Trillium Rail Corridor, and an access to 950 Gladstone Avenue within 5.0 metres of the Loretta Avenue North intersection. Between Loretta Avenue North and Breezehill Avenue, an access loop is located on the north side of Gladstone Avenue to the Canadian Bank Note Limited, and five driveways are located on the south side.

Along Loretta Avenue North, two accesses are provided on the west side of the road for the Canadian Bank Note Limited site, and a single access is located north of the proposed site for 131 Loretta Avenue North. The paved shoulder is used for perpendicular parking along Loretta Avenue North as well.

2.2.4 Cycling and Pedestrian Facilities

Figure 3 illustrates the pedestrian facilities in the study area and Figure 4 illustrates the cycling facilities. Figure 5 and Figure 6 illustrate the existing pedestrian and cycling volumes within the study area.

Sidewalks are provided along both sides of the roadways in the study area with the exception of the east side of Breezehill Avenue between Gladstone Avenue and Laurel Street, on both sides of Laurel Street, and the east side of Loretta Avenue North. The Trillium Pathway is a multi-use pathway along the east side of the Trillium Rail Corridor.

The cycling network consists of the Trillium Pathway as a cross-town bikeway, suggested biking routes along Gladstone Avenue, Bayswater Avenue and Somerset Street W, including bike lanes on the bridge over the Trillium Rail Corridor.

Figure 3: Study Area Pedestrian Facilities

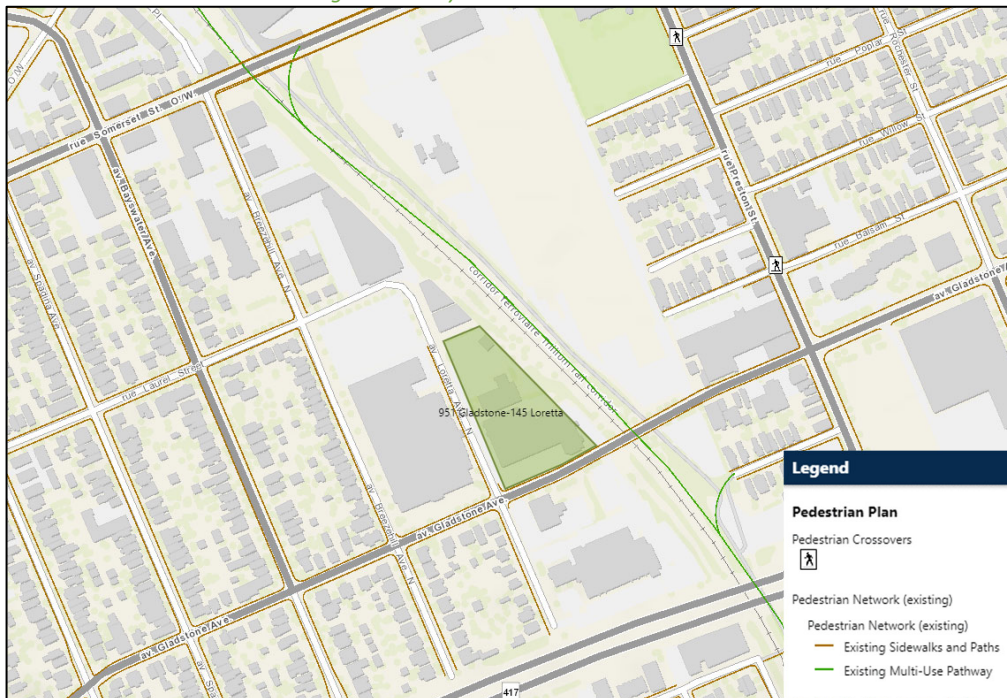

Source: <http://maps.ottawa.ca/geoOttawa/> Accessed: March 31, 2021

Figure 4: Study Area Cycling Facilities

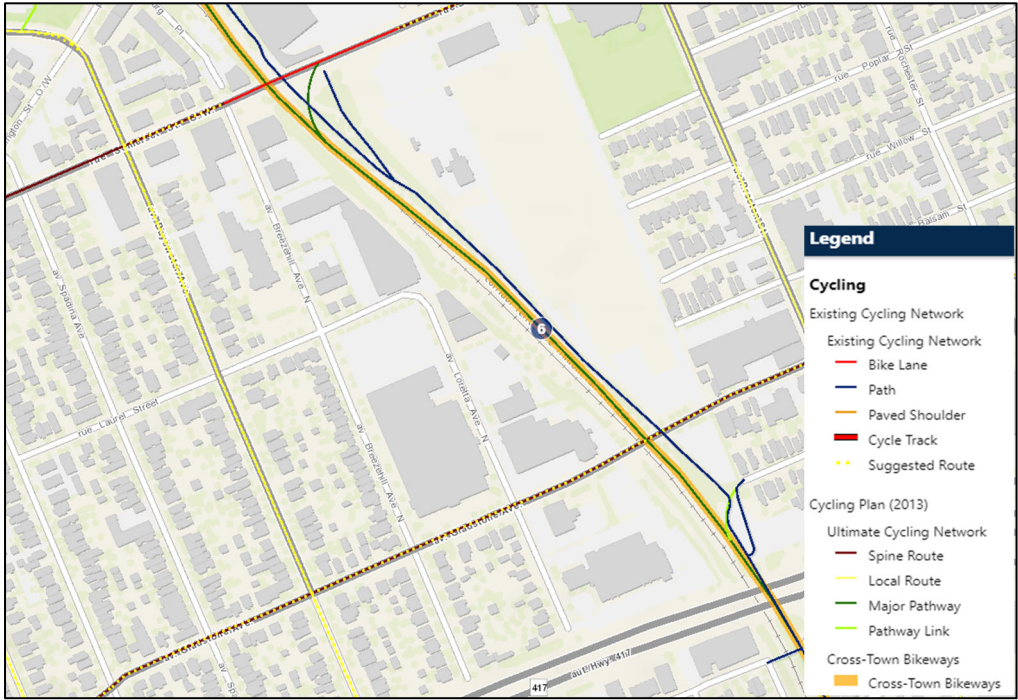

Source: <http://maps.ottawa.ca/geoOttawa/> Accessed: September 27, 2022

Figure 5: Existing Pedestrian Volumes

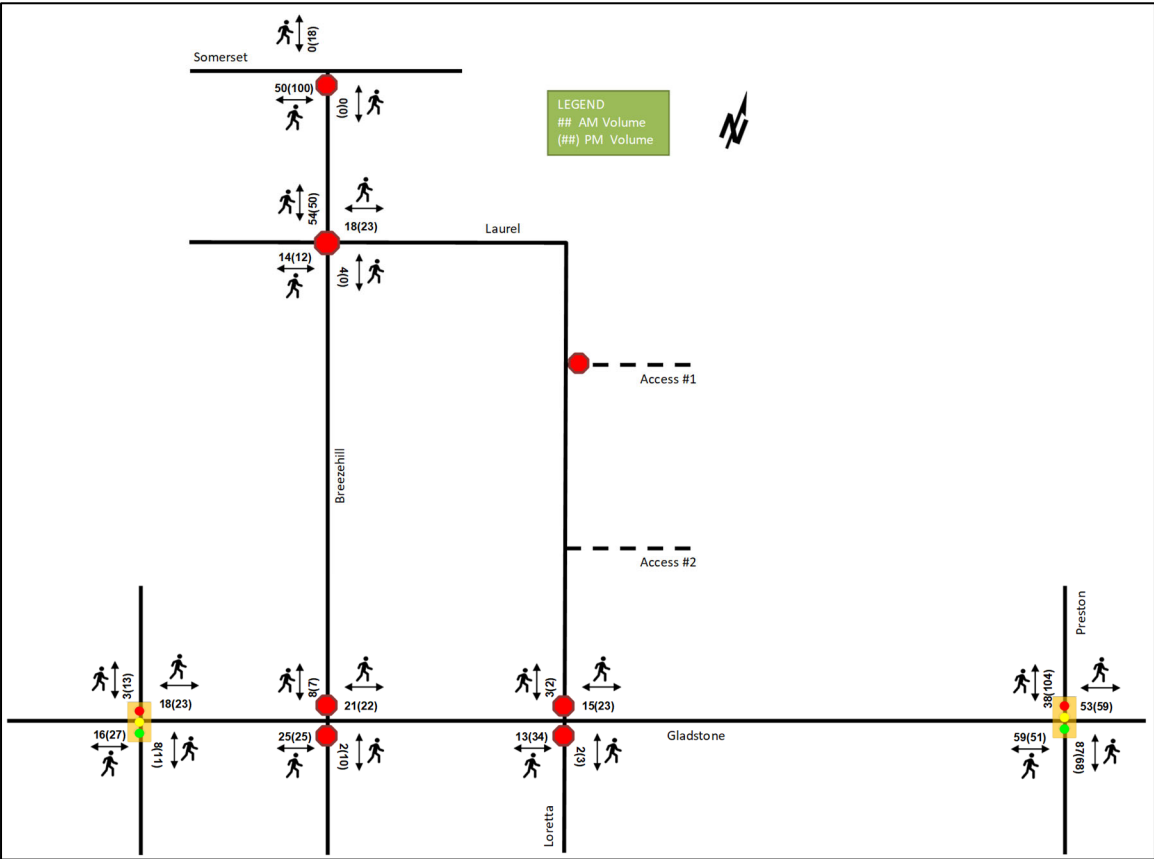
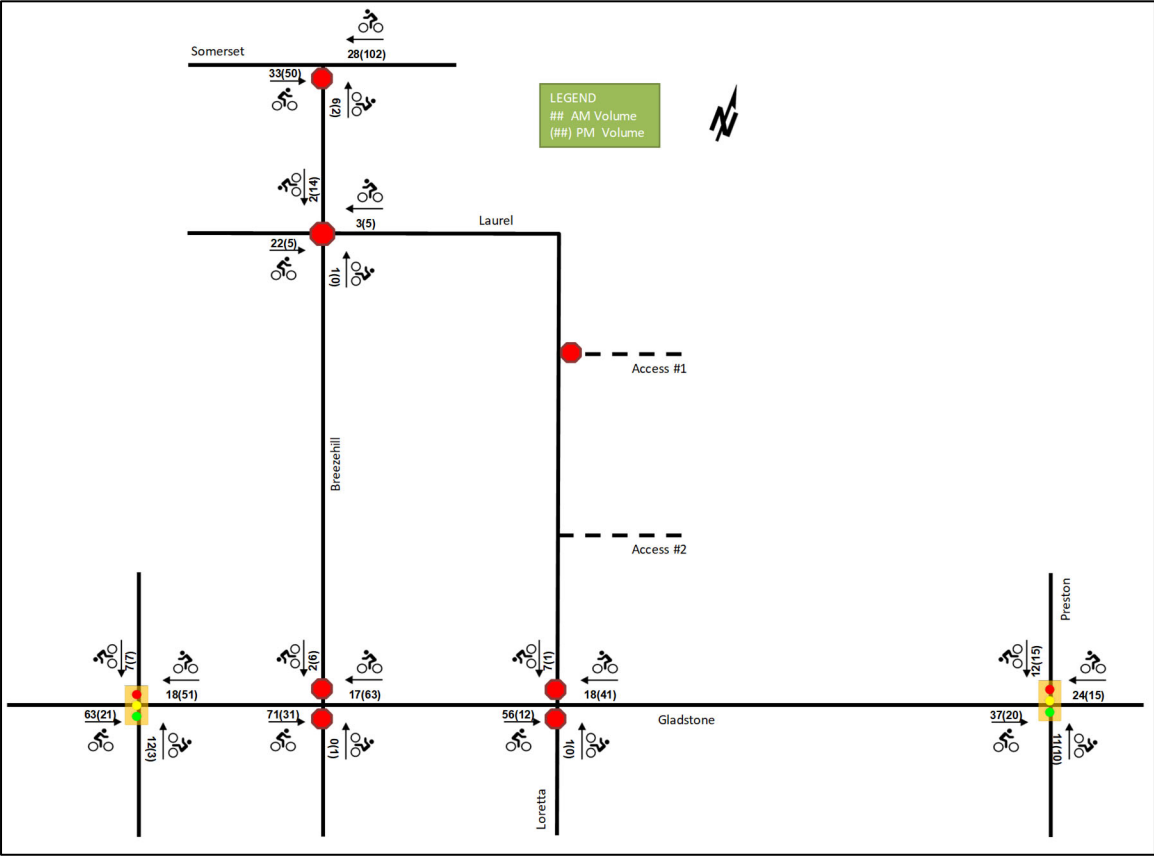

Figure 6: Existing Cycling Volumes



2.2.5 Existing Transit

Within the study area, the routes #11, #14 and #114 run along Gladstone Avenue, Somerset Street and Preston Street. The frequency of these routes within proximity of the proposed site currently are:

- Route #11 – every 10-15 minutes during the day and 20-30 minutes during the evening
- Route # 14 – every 15-20 minutes during the day and 20-30 minutes during the evening
- Route#85 – every 10-20 minutes during the day and 20-30 minutes during the evening
- Route # 114 – two trips during the AM peak to Rideau and two trips during the PM peak to Caldwell/Merivale

Figure 7 illustrates the transit system map in the study area and Figure 8 illustrates nearby transit stops.

Figure 7: Existing Study Area Transit Service

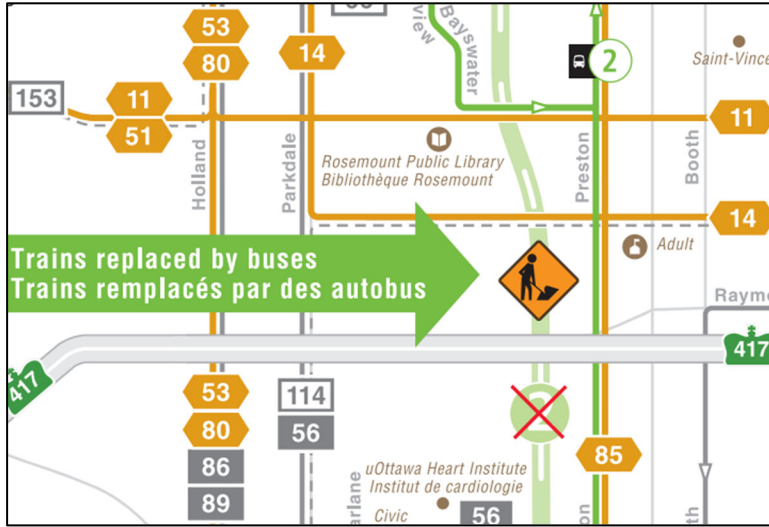

Source: <http://www.octranspo.com/> Accessed: September 27, 2022

Figure 8: Existing Study Area Transit Stops

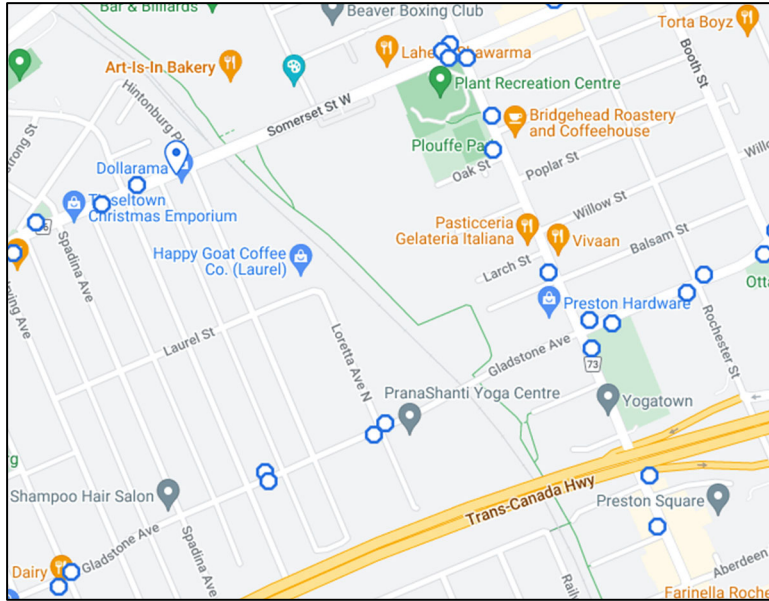

Source: <http://www.octranspo.com/> Accessed: September 27, 2022

2.2.6 Existing Area Traffic Management Measures

There are no existing area traffic management measures within the Study Area.

2.2.7 Existing Peak Hour Travel Demand

Existing turning movement counts were acquired from the City of Ottawa and new traffic count surveys for the existing Study Area intersection. Table 1 summarizes the intersection count dates and sources.

Table 1: Intersection Count Date

Intersection	Count Date	Source
Gladstone Avenue and Bayswater Avenue	Wednesday July 27, 2016	City of Ottawa
Gladstone Avenue and Breezehill Avenue	Wednesday, July 18, 2018	City of Ottawa
Gladstone Avenue and Loretta Avenue	Tuesday, April 23, 2019	The Traffic Specialist
Gladstone Avenue and Preston Street	Tuesday June 20, 2017	City of Ottawa

Intersection	Count Date	Source
Laurel Street and Breezehill Avenue	Tuesday, April 23, 2019	The Traffic Specialist
Somerset Street West and Breezehill Avenue	Thursday August 12, 2015	City of Ottawa

Figure 9 illustrates the existing traffic counts and Table 2 summarizes the existing intersection operations. The level of service for signalized intersections is based on the v/c calculation for individual lane movements and HCM 2000 v/c calculations for the overall intersection, and HCM average delay for unsignalized intersections. The volumes have been balanced through the network. Detailed turning movement count data is included in Appendix B and the Synchro worksheets are provided in Appendix C.

Figure 9: Existing Traffic Counts

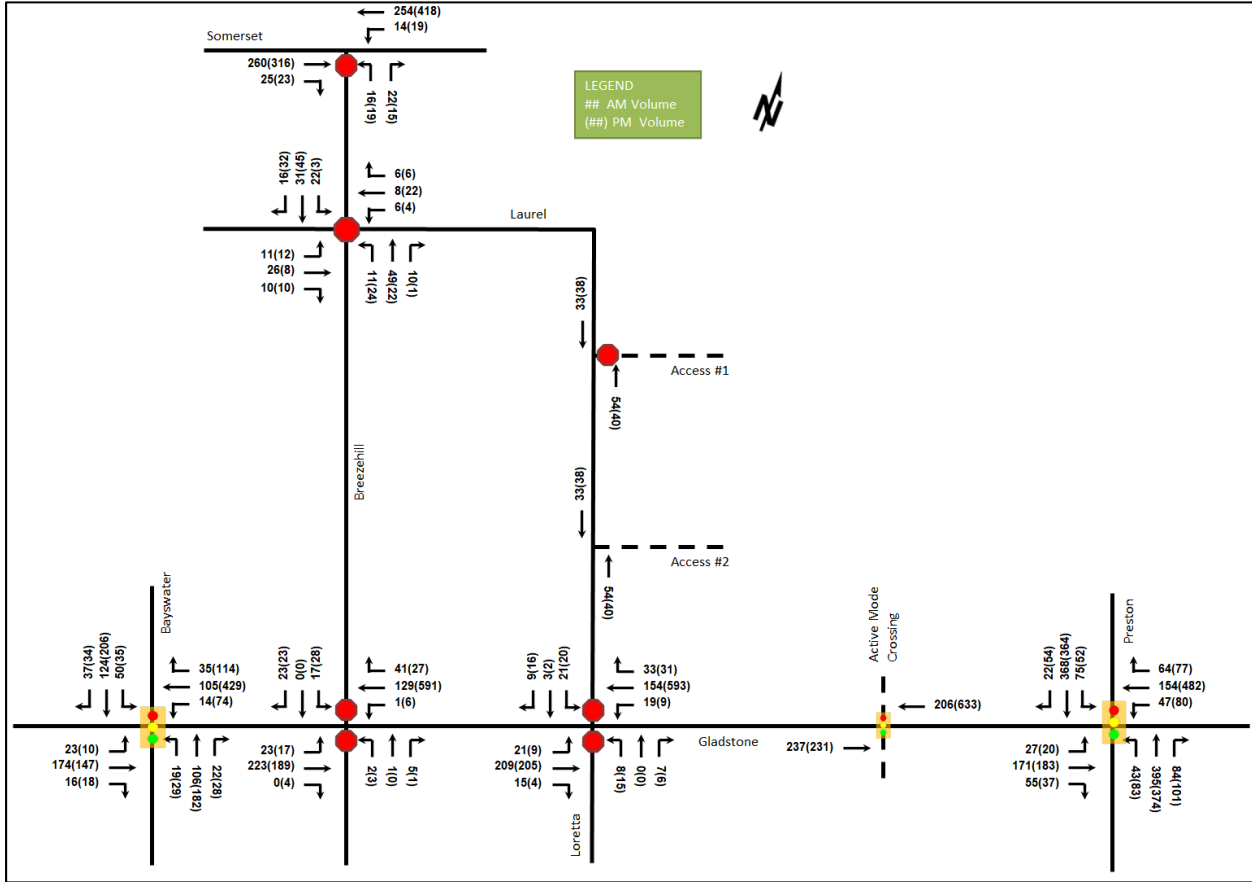

Table 2: Existing Intersection Operations

Intersection	Lane	AM Peak Hour				PM Peak Hour			
		LOS	V/C	Delay	Q (95th)	LOS	V/C	Delay	Q (95th)
Gladstone Avenue & Preston Street <i>Signalized</i>	EB	C	0.76	37.8	#57.3	A	0.50	20.0	47.8
	WBL	A	0.27	23.8	13.6	A	0.23	16.0	17.5
	WBT/R	A	0.59	25.9	43.1	E	0.91	40.2	#140.8
	NBL	A	0.11	8.5	7.6	A	0.39	19.7	19.0
	NBT/R	A	0.55	12.2	68.1	C	0.76	24.4	85.2
	SBL	A	0.23	10.3	12.8	A	0.29	17.7	12.7
	SBT/R	A	0.43	10.7	52.0	B	0.67	21.8	73.0
	<b>Overall</b>	<b>B</b>	<b>0.61</b>	<b>18.3</b>	-	-	<b>D</b>	<b>0.83</b>	<b>27.2</b>

Intersection	Lane	AM Peak Hour				PM Peak Hour			
		LOS	V/C	Delay	Q (95th)	LOS	V/C	Delay	Q (95th)
Gladstone Avenue & Loretta Avenue North <i>Unsignalized</i>	EB	A	0.02	7.8	0.8	A	0.01	9.2	0.0
	WB	A	0.02	7.8	0.8	A	0.01	7.9	0.0
	NB	B	0.03	11.9	0.8	C	0.09	20.3	2.3
	SB	B	0.08	12.9	1.5	C	0.15	20.3	3.8
	<b>Overall</b>	<b>A</b>	-	<b>1.8</b>	-	<b>A</b>	-	<b>1.5</b>	-
Gladstone Avenue & Breezehill Avenue <i>Unsignalized</i>	EB	A	0.02	7.7	0.8	A	0.02	9.2	0.8
	WB	A	0.00	7.8	0.0	A	0.01	7.8	0.0
	NB	B	0.02	11.2	0.0	C	0.02	19.6	0.8
	SB	B	0.07	11.3	1.5	C	0.20	20.9	5.3
	<b>Overall</b>	<b>A</b>	-	<b>1.5</b>	-	<b>A</b>	-	<b>1.5</b>	-
Gladstone Avenue & Bayswater Avenue <i>Signalized</i>	EB	A	0.31	11.3	27.8	A	0.23	8.5	19.8
	WB	A	0.23	8.9	18.4	D	0.85	25.5	#121.1
	NB	A	0.28	13.8	22.9	A	0.52	20.7	41.7
	SB	A	0.42	16.0	33.3	B	0.61	23.0	49.3
	<b>Overall</b>	<b>A</b>	<b>0.35</b>	<b>12.7</b>	-	<b>C</b>	<b>0.75</b>	<b>21.8</b>	-
Somerset Street W & Breezehill Avenue <i>Unsignalized</i>	EB	-	-	-	-	-	-	-	-
	WB	A	0.01	8.2	0.0	A	0.02	8.7	0.8
	NB	B	0.08	12.5	2.3	C	0.12	17.7	3.0
	<b>Overall</b>	<b>A</b>	-	<b>1.0</b>	-	<b>A</b>	-	<b>1.0</b>	-
Laurel Street & Breezehill Avenue <i>Unsignalized</i>	EB	A	0.06	7.5	1.5	A	0.04	7.3	0.8
	WB	A	0.03	7.3	0.8	A	0.04	7.4	0.8
	NB	A	0.09	7.5	2.3	A	0.06	7.5	1.5
	SB	A	0.09	7.5	2.3	A	0.10	7.3	2.3
	<b>Overall</b>	<b>A</b>	-	<b>7.5</b>	-	<b>A</b>	-	<b>7.4</b>	-

Notes: Saturation flow rate of 1800 veh/h/lane  
PHF = 0.90

m = metered queue  
# = volume for the 95th %ile cycle exceeds capacity

During both the AM and PM peak hours, the study area intersection operates well. No capacity issues are noted. The eastbound movements at the intersection of Gladstone Avenue and Preston Street may exhibit extended queues during AM peak. During the PM peak, the westbound queues at the Gladstone Avenue and Preston Street intersection may extend beyond the mid-block and to Rochester Street, and at the Gladstone Avenue and Bayswater Avenue intersection may extend beyond the Breezehill Avenue intersection.

### 2.2.8 Collision Analysis

Collision data have been acquired from the City of Ottawa open data website (data.ottawa.ca) for the recent five years for the surrounding study area road network. Table 3 summarizes the collision types and conditions in the study area, Figure 10 illustrates the intersections and segments analyzed, and Table 4 summarizes the total collisions for each of these locations. Collision data are included in Appendix D.

Table 3: Study Area Collision Summary, 2016-2020

		Number	%
<b>Total Collisions</b>		<b>63</b>	<b>100%</b>
<b>Classification</b>	Fatality	0	0%
	Non-Fatal Injury	25	40%
	Property Damage Only	38	60%
<b>Initial Impact Type</b>	Approaching	1	2%
	Angled	17	27%
	Rear end	12	19%
	Sideswipe	6	10%

		Number	%
<b>Total Collisions</b>		<b>63</b>	<b>100%</b>
	Turning Movement	13	21%
	SMV Unattended	4	6%
	SMV Other	8	13%
	Other	2	3%
<b>Road Surface Condition</b>	Dry	38	60%
	Wet	11	17%
	Loose Snow	4	6%
	Slush	6	10%
	Packed Snow	1	2%
	Ice	3	5%
<b>Pedestrian Involved</b>		<b>7</b>	<b>11%</b>
<b>Cyclists Involved</b>		<b>7</b>	<b>11%</b>

Figure 10: Study Area Collision Records – Representation of 2016-2020

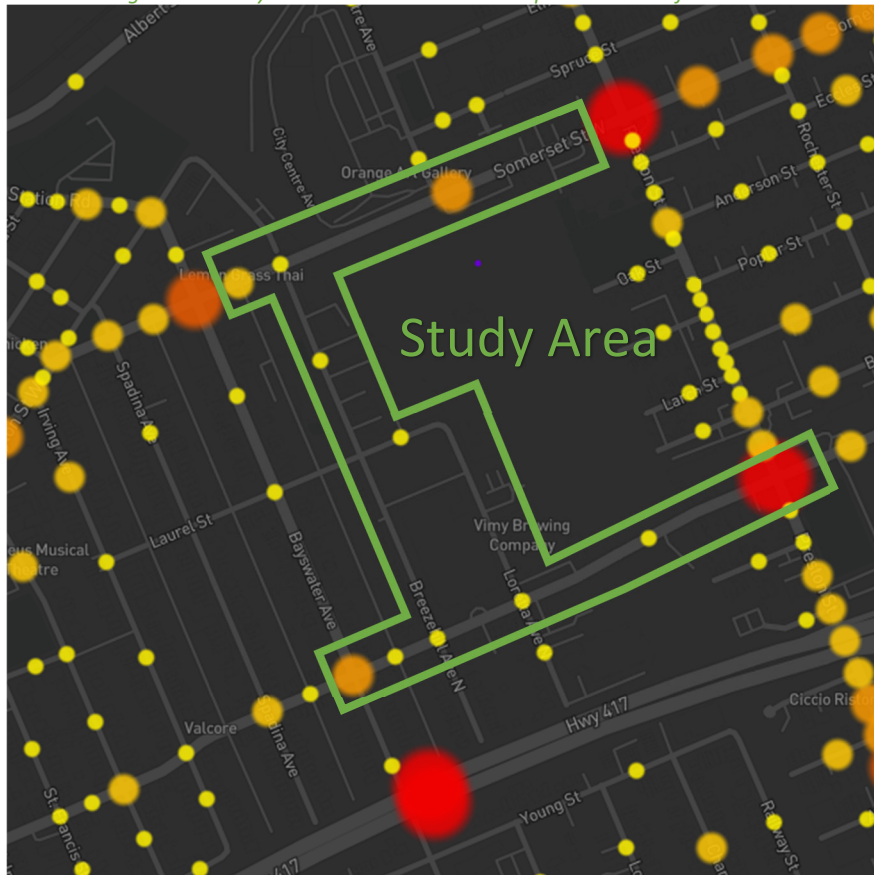

Table 4: Summary of Collision Locations, 2016-2020

Intersections / Segments	Number	%
<b>Gladstone Avenue @ Bayswater Avenue</b>	<b>14</b>	<b>22%</b>
<b>Gladstone Avenue @ Breezehill Avenue</b>	<b>3</b>	<b>5%</b>
<b>Gladstone Avenue @ Loretta Avenue</b>	<b>1</b>	<b>2%</b>
<b>Gladstone Avenue @ Preston Street</b>	<b>19</b>	<b>30%</b>
<b>Gladstone Avenue btwn Bayswater Avenue &amp; Breezehill Avenue N</b>	<b>2</b>	<b>3%</b>
<b>Gladstone Avenue btwn Loretta Avenue N &amp; Preston Street</b>	<b>3</b>	<b>5%</b>

Gladstone Avenue btwn Breezehill Avenue & Loretta Avenue	1	2%
Somerset Street W btwn Bayswater Avenue & Breezehill Avenue N	7	11%
Somerset Street W btwn Breezehill Avenue N & Preston Street	11	17%
Breezehill Avenue N btwn Somerset Street W & Laurel Street	1	2%
Laurel Street btwn Breezehill Avenue N & Loretta Avenue N	1	2%

Within the study area, the intersection of Gladstone Avenue at Bayswater Avenue and Gladstone Avenue at Preston Street, and the segment of Somerset Street W between Breezehill Avenue and Preston Street are noted to have experienced higher collisions than other intersections. Table 5, Table 6 and Table 7 summarize the collision types and conditions for each of these locations.

*Table 5: Gladstone Avenue and Bayswater Avenue Collision Summary*

		Number	%
<b>Total Collisions</b>		<b>14</b>	<b>100%</b>
<b>Classification</b>	<b>Fatality</b>	0	0%
	<b>Non-Fatal Injury</b>	5	36%
	<b>Property Damage Only</b>	9	64%
<b>Initial Impact Type</b>	<b>Angle</b>	5	35%
	<b>Rear end</b>	4	29%
	<b>Turning Movement</b>	3	21%
	<b>SMV Other</b>	2	14%
<b>Road Surface Condition</b>	<b>Dry</b>	9	64%
	<b>Wet</b>	2	14%
	<b>Loose Snow</b>	2	14%
	<b>Packed Snow</b>	1	7%
<b>Pedestrian Involved</b>		2	14%
<b>Cyclists Involved</b>		0	0%

The Gladstone Avenue and Bayswater Avenue intersection had a total of 14 collisions during the 2016-2020 time period, with nine involving property damage only and the remaining five having non-fatal injuries. The collision types are most represented by angled (five collisions) and rear-end (four collisions) and the remaining split between turning movement and single motor vehicle. The angled collisions may be subject to weather conditions as two are loose snow and one was wet weather conditions. Weather conditions do not affect collisions at this location. No other patterns are noted within the collision data and no mitigation is recommended.

*Table 6: Gladstone Avenue and Preston Street Collision Summary*

		Number	%
<b>Total Collisions</b>		<b>19</b>	<b>100%</b>
<b>Classification</b>	<b>Fatality</b>	0	0%
	<b>Non-Fatal Injury</b>	9	47%
	<b>Property Damage Only</b>	10	53%
<b>Initial Impact Type</b>	<b>Angle</b>	2	10%
	<b>Rear end</b>	6	32%
	<b>Sideswipe</b>	2	10%
	<b>Turning Movement</b>	4	21%
	<b>SMV Other</b>	5	26%
<b>Road Surface Condition</b>	<b>Dry</b>	9	47%
	<b>Wet</b>	4	21%
	<b>Loose Snow</b>	1	4%
	<b>Slush</b>	3	16%
	<b>Ice</b>	2	10%

	Number	%
<b>Total Collisions</b>	<b>19</b>	<b>100%</b>
<b>Pedestrian Involved</b>	4	21%
<b>Cyclists Involved</b>	2	10%

The Gladstone Avenue and Preston Street intersection had a total of 19 collisions during the 2016-2020 time period, with 10 involving property damage only and the remaining nine having non-fatal injuries. The collision types are most represented by rear-end (six collisions), SMV other (five collisions), and sideswipe, turning movement and angled with four or less each. Pedestrian and bicycles were involved in 31% of the collisions at the intersection and this aligns with the safety review completed by the City in 2020 for this intersection. Intersection improvements were recommended to include buffered/protected cycling approaches to the intersection, thermoplast bike crossing markings, truck aprons to reduce turn radii and reducing all approaches to single shared movement lanes. Weather conditions do not affect collisions at this location. No further review is required as part of this study.

*Table 7: Somerset Street W between Breezehill Avenue and Preston Street Collision Summary*

	Number	%	
<b>Total Collisions</b>	<b>11</b>	<b>100%</b>	
<b>Classification</b>	<b>Fatality</b>	0	0%
	<b>Non-Fatal Injury</b>	6	45%
	<b>Property Damage Only</b>	5	55%
<b>Initial Impact Type</b>	<b>Angle</b>	3	27%
	<b>Sideswipe</b>	3	27%
	<b>Turning Movement</b>	4	36%
	<b>SMV Unattended</b>	1	9%
<b>Road Surface Condition</b>	<b>Dry</b>	9	79%
	<b>Wet</b>	2	21%
<b>Pedestrian Involved</b>	0	0%	
<b>Cyclists Involved</b>	5	55%	

The Somerset Street W segment between Breezehill Avenue and Preston Street had a total of 11 collisions during the 2016-2020 time period, with five involving property damage only and six having non-fatal injuries. The collision types are evenly distributed with turning movements with four each, sideswipe and angled with three each and a single unattended vehicle. The collisions are assumed to be a result of the on-street parking and commercial/retail access located on the east side of the Trillium Line overpass, through a combination of parked cars, dooring, loading vehicles, infrequent access traffic and the Plant Recreation Centre access. This area also has shared road cycling facilities, where as the overpass has bike lanes west to Breezehill Avenue, and likely contributes to the cycling collision frequency of approximately one per year. Weather conditions do not affect collisions at this location. No further review is required as part of this study although the City should initiate a review for potential mitigation along Somerset Street, similar to the intersection study done for Somerset Street and Bayswater Avenue.

## 2.3 Planned Conditions

### 2.3.1 Changes to the Area Transportation Network

The subject development is within the Gladstone Station District CDP (2014) and as such, is subject to the development and planning vision outlined with the CDP. The CDP visioning option for the transit-oriented development node, illustrated in Figure 11, has the following new transportation infrastructure elements:

- Trillium LRT station plaza identified as a node/landmark/gateway for the community (estimated 2023)

- a multi-use crossing is proposed over the rail line between Gladstone Avenue and Laurel Street W
- a new road connection across the rail line between Laurel Street W and Oak Street

Beyond the station plaza, these improvements are not identified in the City's affordable network and no time frame is available for their construction.

Figure 11: Gladstone Station District CDP Vision & Concept Options Report – Preferred Option: Perspective Looking North-East

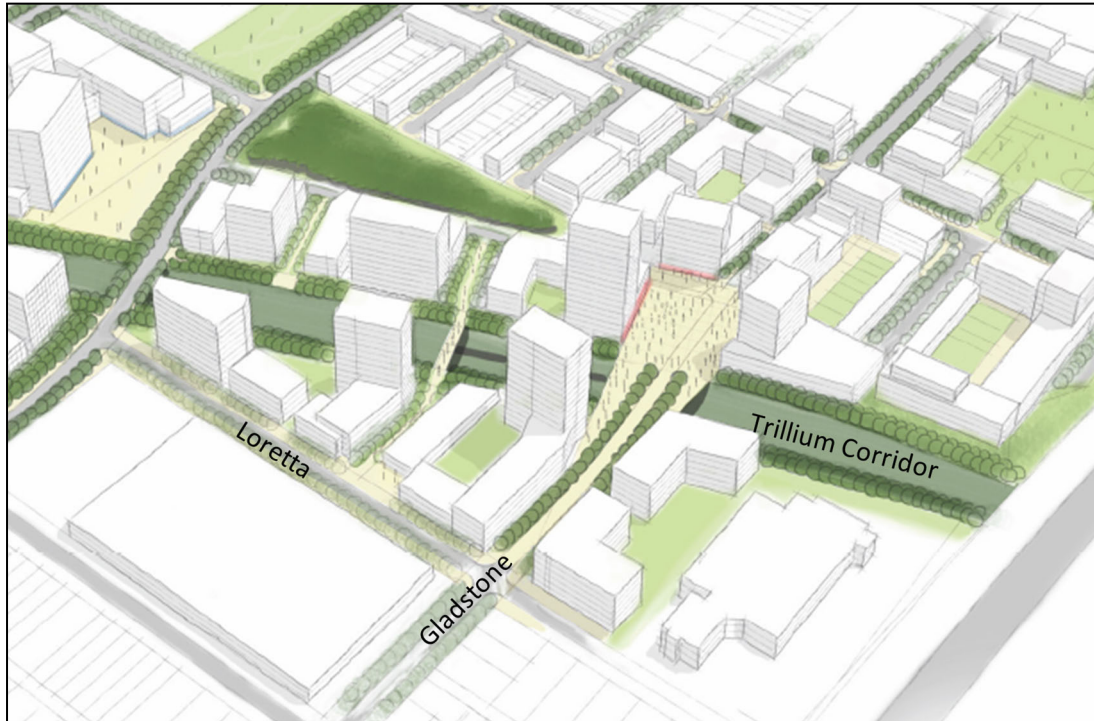

### 2.3.2 Other Study Area Developments

The following developments were available on Ottawa's devapps service at the time of this study. Files added subsequently should include this site within their background conditions.

#### *1040 and 1050 Somerset Street*

The combined site would include a 32-storey residential building between the Trillium Rail corridor and Breezehill Avenue, and a 23-storey residential building on the west side of Breezehill Avenue. Both sites would include ground floor commercial/retail and provide underground parking. Access to the 1040 site was proposed along Breezehill Avenue and a laneway access on Somerset Street West was proposed for the 1050 site. This application file has not advanced since 2013.

#### *989 Somerset Street*

The proposed development consists of a mixed-use building with ground floor retail and 127 residential units above. The transportation impact of this site will be primarily on Somerset Street West and Preston Street. In addition, this file has not advanced since 2014.

#### *975 Gladstone Avenue*

An addition to the existing Canada Bank Note building is proposed on the rear of the building, consisting of 947m<sup>2</sup> warehousing space and a 177m<sup>2</sup> secure interior loading bay. The planning rationale states that the addition supports the existing light industrial business and not generate any increase of vehicular trips.

#### *139-143 Balsam Street and 20 Larch Street*

The proposed demolish control applications was submitted to remove the existing buildings on site. The properties would remain in an interim condition until such time redevelopment occurs in accordance with the Gladstone Station CDP.

### 3 Study Area and Time Periods

#### 3.1 Study Area

The study area will include the intersections of:

- Gladstone Avenue at:
  - Bayswater Avenue
  - Breezehill Avenue
  - Loretta Avenue
  - Preston Street
- Breezehill Avenue at:
  - Laurel Street
  - Somerset Street
- Loretta Avenue at:
  - Site Access #1 (outbound)
  - Site Access #2 (inbound)

The boundary roads will be Gladstone Avenue and Loretta Avenue. The TRANS screenline SL-29 was reviewed during the zoning bylaw amendment application and no issues were noted. No additional screenline analysis will be provided within this TIA.

#### 3.2 Time Periods

As the proposed development is composed predominantly by residential and office, the AM and PM peak hours will be examined.

#### 3.3 Horizon Years

The anticipated build-out year is 2026. As a result, the full build-out plus five years horizon year is 2031.

### 4 Exemption Review

Table 8 summarizes the exemptions for this TIA.

*Table 8: Exemption Review*

Module	Element	Explanation	Exempt/Required
<b>Design Review Component</b>			
<b>4.1 Development Design</b>	4.1.2 Circulation and Access	Only required for site plans	Required
	4.2.3 New Street Networks	Only required for plans of subdivision	Exempt
<b>4.2 Parking</b>	4.2.1 Parking Supply	Only required for site plans	Required
	4.2.2 Spillover Parking	Only required for site plans where parking supply is 15% below unconstrained demand	Exempt
<b>Network Impact Component</b>			

Module	Element	Explanation	Exempt/Required
<b>4.5 Transportation Demand Management</b>	All Elements	Not required for site plans expected to have fewer than 60 employees and/or students on location at any given time	Required
<b>4.6 Neighbourhood Traffic Management</b>	4.6.1 Adjacent Neighbourhoods	Only required when the development relies on local or collector streets for access and total volumes exceed ATM capacity thresholds	Required
<b>4.8 Network Concept</b>		Only required when proposed development generates more than 200 person-trips during the peak hour in excess of equivalent volume permitted by established zoning	Exempt (site plan matches new zoning)

## 5 Development-Generated Travel Demand

### 5.1 Mode Shares

Examining the mode shares recommended in the TRANS Trip Generation Manual (2020) for the subject district, derived from the most recent National Capital Region Origin-Destination survey (OD Survey), the existing average district mode shares by land use for Ottawa West have been summarized in Table 9.

*Table 9: TRANS Trip Generation Manual Recommended Mode Shares – Ottawa West*

Travel Mode	Multi-Unit (High-Rise)		Commercial Generator	
	AM	PM	AM	PM
<b>Auto Driver</b>	28%	33%	55%	50%
<b>Auto Passenger</b>	11%	11%	11%	16%
<b>Transit</b>	41%	26%	11%	11%
<b>Cycling</b>	3%	7%	0%	5%
<b>Walking</b>	16%	23%	23%	18%
<b>Total</b>	<b>100%</b>	<b>100%</b>	<b>100%</b>	<b>100%</b>

Since the site is being within the TOD area, a higher transit mode is considered achievable at this location. A 24% shift to transit mode from the auto driver mode and six percent shift from the auto passenger mode is proposed for both residential and non-residential land uses. The modified mode share targets are proposed for the development and are summarized in Table 10.

*Table 10: Proposed Development Mode Shares*

Travel Mode	Multi-Unit (High-Rise)		Commercial Generator	
	AM	PM	AM	PM
<b>Auto Driver</b>	10%	15%	55%	50%
<b>Auto Passenger</b>	5%	5%	11%	16%
<b>Transit</b>	65%	50%	11%	11%
<b>Cycling</b>	3%	7%	0%	5%
<b>Walking</b>	16%	23%	23%	18%
<b>Total</b>	<b>100%</b>	<b>100%</b>	<b>100%</b>	<b>100%</b>

### 5.2 Trip Generation

This TIA has been prepared using the vehicle and person trip rates for the residential dwellings using the TRANS Trip Generation Manual (2020) and the vehicle trip rates and derived person trip rates for commercial component from the ITE Trip Generation Manual 10th Edition (2017) using the City-prescribed conversion factor of 1.28. Table

11 summarizes the person trip rates for the proposed residential land uses for each peak period and the person trip rates for the non-residential land uses by peak hour.

*Table 11: Trip Generation Person Trip Rates by Peak Period*

Land Use	Land Use Code	Peak Period	Person Trip Rates	Note
<b>Multi-Unit (High-Rise)</b>	221 & 222 (TRANS)	AM	0.80	Urban
		PM	0.90	
<b>General Office</b>	710 (ITE)	AM	1.38	ITE Harmonized
		PM	1.41	
<b>Shopping Centre</b>	820 (ITE)	AM	1.2	ITE Harmonized
		PM	4.88	

Using the above person trip rates, the total person trip generation has been estimated. Table 11 summarizes the total person trip generation for the residential land uses and for the non-residential land uses.

*Table 12: Total Development Person Trip Generation by Peak Period*

Land Use	Units / GFA	AM Peak Period			PM Peak Period		
		In	Out	Total	In	Out	Total
<b>Multi-Unit (High-Rise)</b>	849	210	469	679	443	321	764
<b>General Office</b>	193,015	229	37	266	44	228	272
<b>Shopping Centre</b>	17,611	13	8	21	41	45	86

Internal capture rates from the ITE Trip Generation Handbook 3<sup>rd</sup> Edition have been assigned to the development’s retail component for mixed-use developments. The rates summarized in Table 13 represent the percentage of trips to/from the office and retail use based on the residential component.

*Table 13: Internal Capture Rates*

Land Use	AM		PM	
	In	Out	In	Out
<b>Residential to/from General Office</b>	3%	1%	57%	2%
<b>Residential to/from Shopping Centre</b>	17%	14%	10%	26%

Using the above mode share targets for a TOD area, the internal capture, and the person trip rates, the person trips by mode have been projected. Trip generation by peak hour has been forecasted using the prescribed peak period conversion factors presented in the TRANS Trip Generation Manual (2020) for the residential component. Table 14 summarizes the residential trip generation and the non-residential trip generation by mode and peak hour.

*Table 14: Development Trip Generation by Mode*

Travel Mode		AM Peak Hour				PM Peak Hour			
		Mode Share	In	Out	Total	Mode Share	In	Out	Total
<b>Multi-Unit (High-Rise)</b>	Auto Driver	10%	10	23	33	15%	29	21	51
	Auto Passenger	5%	5	11	16	5%	10	7	17
	Transit	65%	75	168	243	50%	104	76	180
	Cycling	3%	3	8	11	7%	15	11	25
	Walking	16%	20	44	64	23%	53	38	92
	<b>Total</b>	<b>100%</b>	<b>113</b>	<b>254</b>	<b>367</b>	<b>100%</b>	<b>211</b>	<b>153</b>	<b>365</b>
<b>General Office</b>	Auto Driver	37%	82	14	96	32%	6	71	77
	Auto Passenger	5%	11	2	13	10%	2	22	24
	Transit	35%	78	13	91	35%	7	78	85

Travel Mode	AM Peak Hour				PM Peak Hour				
	Mode Share	In	Out	Total	Mode Share	In	Out	Total	
Cycling	0%	0	0	0	5%	1	11	12	
Walking	23%	51	9	60	18%	3	40	44	
Internal Capture	varies	-7	0	-7	varies	-25	-5	-30	
<b>Total</b>	<b>100%</b>	<b>229</b>	<b>38</b>	<b>267</b>	<b>100%</b>	<b>44</b>	<b>227</b>	<b>272</b>	
Shopping Centre	Auto Driver	37%	4	3	7	32%	12	10	22
	Auto Passenger	5%	1	0	1	10%	4	3	7
	Transit	35%	4	2	6	35%	13	12	25
	Cycling	0%	0	0	0	5%	2	2	4
	Walking	23%	3	2	4	18%	7	6	13
	Internal Capture	varies	-2	-1	-3	varies	-4	-12	-16
	<b>Total</b>	<b>100%</b>	<b>14</b>	<b>8</b>	<b>21</b>	<b>100%</b>	<b>42</b>	<b>45</b>	<b>87</b>
Total	Auto Driver	-	96	40	136	-	47	102	149
	Auto Passenger	-	17	13	30	-	16	32	48
	Transit	-	157	183	340	-	124	166	290
	Cycling	-	3	8	12	-	18	24	41
	Walking	-	74	55	127	-	63	84	149
	<b>Total</b>	<b>-</b>	<b>347</b>	<b>299</b>	<b>645</b>	<b>-</b>	<b>268</b>	<b>408</b>	<b>678</b>

As shown above, a total of 136 AM and 149 PM new peak hour two-way vehicle trips are projected as a result of the proposed development.

### 5.3 Trip Distribution

To understand the travel patterns of the subject development the OD Survey has been reviewed to determine the travel patterns for the Ottawa West area. Table 15 below summarizes the distributions.

Table 15: OD Survey Distribution

To/From	Ottawa West	Routing
North	5%	via Somerset (2.5% east and west)
South	30%	via Gladstone (15% west), Preston (15% south)
East	30%	via Gladstone (15% east), Preston (5% south), Preston (5% north), Gladstone (5% west to Hwy 417)
West	35%	via Laurel (5%) west, Somerset (5% west), Gladstone (25% west)
<b>Total</b>	<b>100%</b>	

Note: internal trips applied to west direction

### 5.4 Trip Assignment

Using the distribution outlined above, turning movement splits, and access to major transportation infrastructure, the trips generated by the site have been assigned to the study area road network. Figure 12 illustrates the new site generated volumes.

Figure 12: New Site Generation Auto Volumes

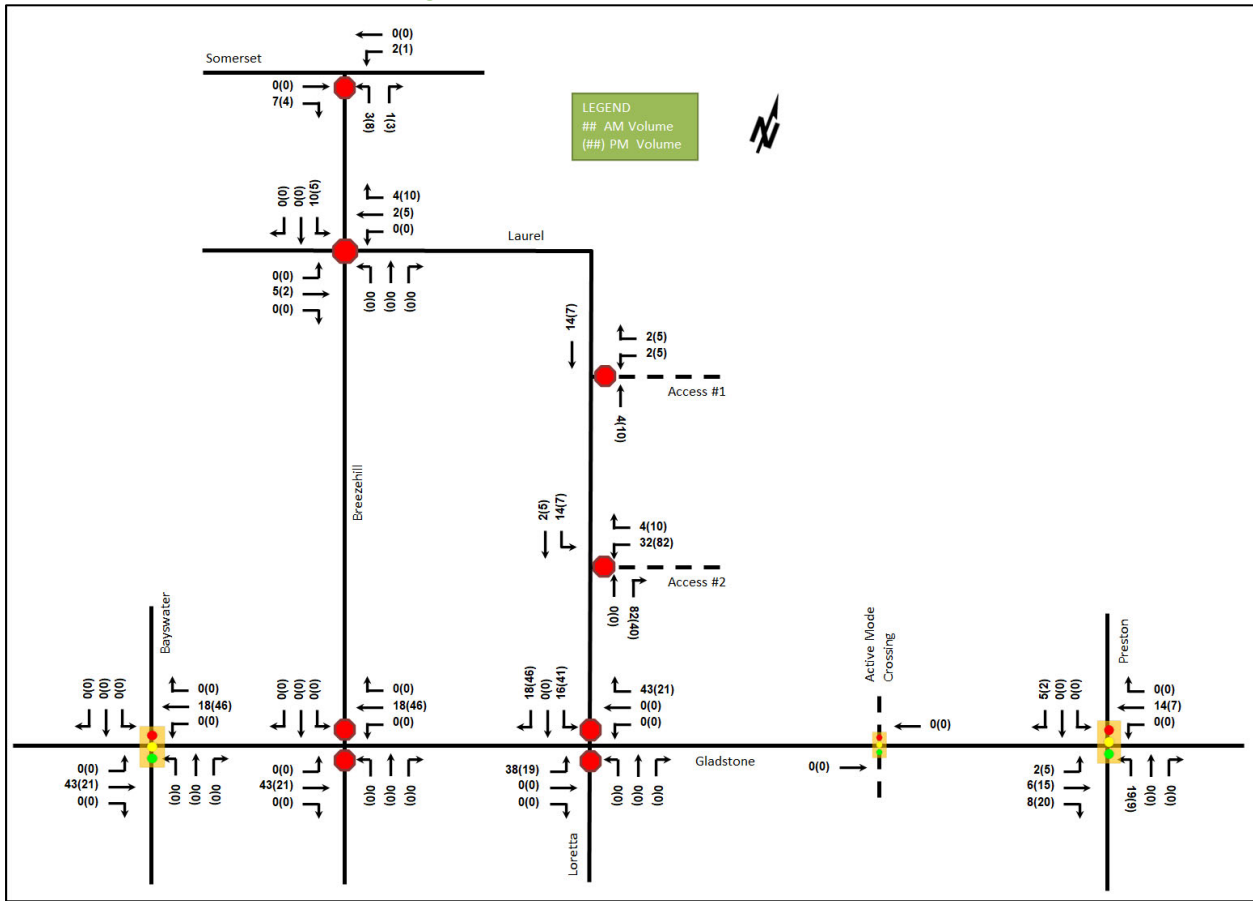

## 6 Background Network Travel Demands

### 6.1 Transportation Network Plans

The transportation network plans were discussed in Section 2.3.1. Beyond the opening of the Trillium LRT Corso Italia, no additional network changes have been included in the preparation of this TIA.

### 6.2 Background Growth

The auto demand within the inner area of Ottawa has been documented as decreasing over the past 10 years, resulting in reduced demand on many roadways. As such, no growth has been applied to the study area intersections. This is consistent with the zoning bylaw amendment TIA.

### 6.3 Other Developments

No background developments were explicitly considered as part of this TIA as no active files were documented within the area at the time. The future background traffic volumes are anticipated to remain the same as the existing conditions and no improvements are recommended.

## 7 Demand Rationalization

### 7.1 Modal Share Sensitivity

No capacity constraints have been noted at the study area intersections. As this development is targeted for a transit focus and meets the planned context of this area, rationalization for adjusted demand is not required for this TIA.

## 8 Development Design

### 8.1 Design for Sustainable Modes

The proposed development is a mixed-use development, with four surface parking spaces and 556 underground parking spaces. Of the total 560 parking spaces, 30 will be designated for visitor parking, 423 spaces for the residential component, 91 for the office and live-work components, and 16 for the retail component. It is anticipated that 423 bicycle parking spaces will be provided for the residential component and 80 bicycle spaces shared for the office, retail, and live-work components.

As part of the site plan, the plaza located between Towers 2 and 3 will provide access to the MUP on the west side of the Trillium LRT line, and the area between the Standard Bread and Trillium LRT line will be reconstructed as a pedestrian plaza for active mode connectivity to Corso Italia.

### 8.2 Circulation and Access

Vehicle access is provided via a two-way access on Loretta Avenue to the Towers 1 and 2 loading and underground garage and a one-way loop to the north that exits onto Loretta Avenue. The two-way access is 8.0m wide and the one-way loop is 6.7m wide. An additional access point is provided to Tower 3 from Loretta Avenue for move-in and garbage pick up. No general vehicle access is authorized at this access location. This additional access location is 6.0m in width. The one-way loop is designated as the fire route within the site. These accesses meet the Private Approach Bylaw widths.

The pedestrian and active mode access is provided along Gladstone Avenue for the Standard Bread building, retail components, and through connection into the site. Along Loretta Avenue, the lobby accesses are all located on the one-way loop.

The garbage truck, move in truck and fire truck turning movements can be accommodated on site.

## 9 Parking

### 9.1 Parking Supply

The site provides 423 parking spaces for the residential component, 30 visitor parking spaces, 91 parking spaces for the office and live-work components, and 16 parking spaces for the retail component. It is anticipated that 423 bicycle parking spaces will be provided for the residential component and 80 bicycle spaces shared for the office, retail, and live-work components. The resulting parking ratios for the site are summarized in Table 16. It is noted that the parking provisions are within a TOD zone and are below the maximum parking provisions.

*Table 16: Proposed Parking Ratios*

	<b>Residential</b>	<b>Office/Live-Work</b>	<b>Retail</b>
<b>Parking Ratio</b>	0.50 per unit	0.50 per 1076 sq. ft.	1.00 per 1076 sq. ft.

## 10 Boundary Street Design

Table 17 summarizes the MMLOS analysis for the boundary streets of Gladstone Avenue and Loretta Avenue N. The Gladstone Avenue existing and future conditions will be the same and are considered in one row and the Loretta Avenue N will be split between existing and future conditions. The boundary street analysis is based on the policy area of “within 600m of a rapid transit station”. The MMLOS worksheets has been provided in Appendix E.

Table 17: Boundary Street MMLOS Analysis

Segment	Pedestrian LOS		Bicycle LOS		Transit LOS		Truck LOS	
	PLOS	Target	BLOS	Target	TLOS	Target	TrLOS	Target
Gladstone Avenue	<b>C</b>	A	<b>D</b>	B	D	D	-	-
Loretta Avenue North (existing)	<b>F</b>	A	B	D	-	-	-	-
Loretta Avenue North (future)	A	A	B	D	-	-	-	-

Gladstone Avenue and the existing Loretta Avenue N segments do not meet the pedestrian MMLOS target. Gladstone Avenue would require reduced traffic and a boulevard of 0.5m or greater to meet the PLOS A target. The addition of a sidewalk and landscaping along the Loretta Avenue N frontage will meet the PLOS target.

Gladstone Avenue segment do not meet the bicycle MMLOS target. To meet the target, operating speed has to be reduced to less or equal to 40 km/h.

## 11 Access Intersections Design

### 11.1 Location and Design of Access

The vehicle access will be located along Loretta Avenue N on a two-way driveway to the underground ramp, and a one-way loop will extend north to exit onto Loretta Avenue N. A secondary garbage truck/move-in access for Tower 3 located at the north of the site. The inbound access is located approximately 55 metres north of Gladstone Avenue and will be 8.0 metres wide to accommodate all turning movements, and the outbound access is located approximately 105 metres north of Gladstone Avenue and will be 6.7 metres wide, permitting left and right turn lanes. The Tower 3 garbage/move-in access is located approximately 4 metres south of the northern property limit and is 6.0 metres wide.

The two-way access throat length is approximately 7.4 metres to the turn of the one-way loop radius and 20.7 metres to the first parking stall. The one-way outbound throat length is approximately 7.3 metre from the property line to the end the turn of the one-way loop radius and 26.2 metres to the first parking space. The Tower 3 garbage/move-in access provides approximately 10.6 metres from the property line to the loading door.

The 8.0m two-way access is noted to exceed the Private Approach Bylaw Section 25(d), but is required to permit truck northbound turning movements into the site from Loretta Avenue N.

### 11.2 Intersection Control

The outbound site access will include a stop sign control and one-way signage will be provided at each of the inbound and outbound access locations. No other access control is recommended for the site.

### 11.3 Access Intersection Design

#### 11.3.1 Future Total Access Intersection Operations

The future total intersection volumes are illustrated in Figure 13 and the access intersection operations are summarized below in Table 18. Synchro 11 has been used to model the unsignalized intersections and the HCM

2010 methodology was used for unsignalized intersection operations. The synchro worksheets have been provided in Appendix F.

Figure 13: Future Total Volumes

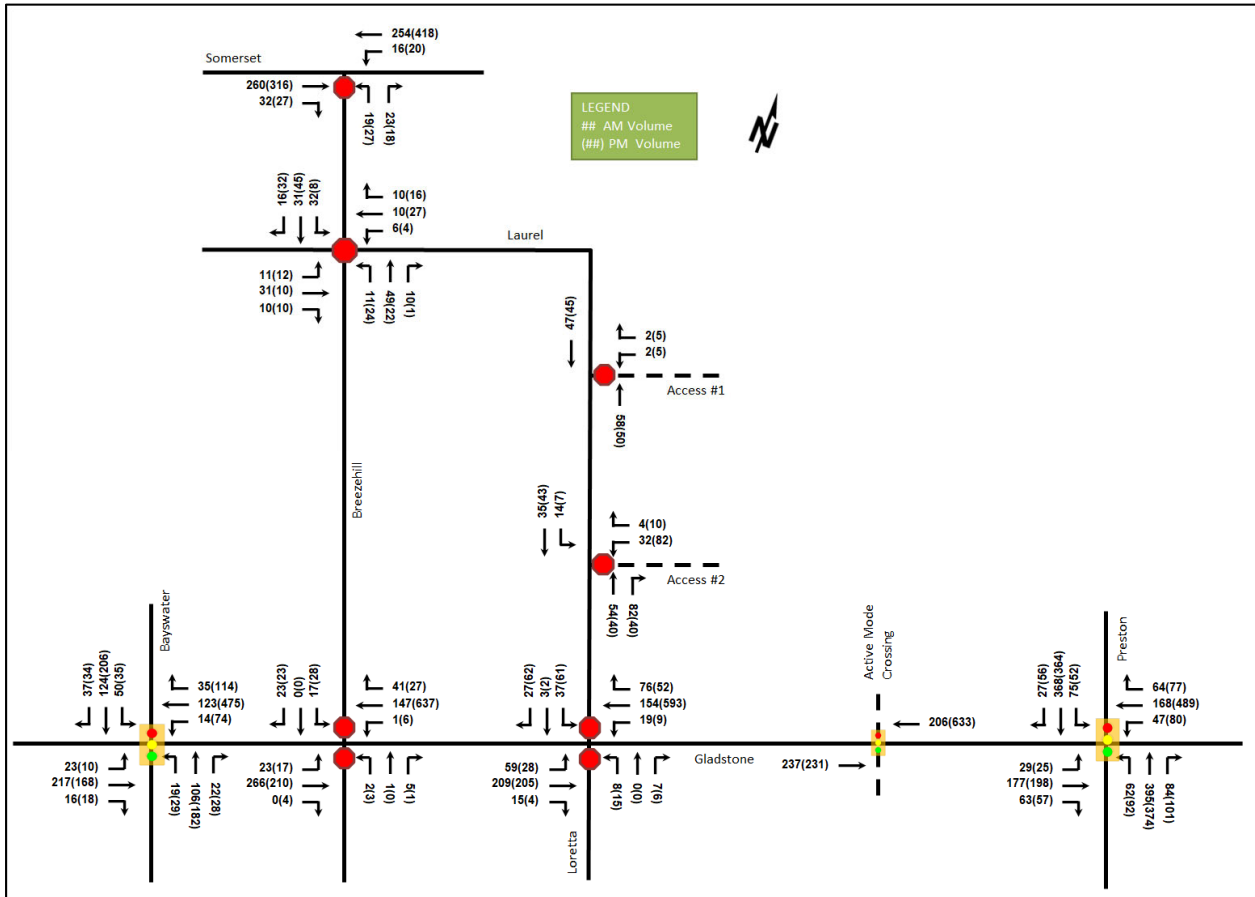

Table 18: Future Total Access Intersection Operations

Intersection	Lane	AM Peak Hour				PM Peak Hour			
		LOS	V/C	Delay	Q (95th)	LOS	V/C	Delay	Q (95th)
Access #1 & Loretta Avenue N Unsignalized	WBL	A	0.00	8.8	0.0	A	0.01	8.8	0.0
	NB	-	-	-	-	-	-	-	-
	SB	-	-	-	-	-	-	-	-
	<b>Overall</b>	<b>A</b>	-	<b>0.3</b>	-	<b>A</b>	-	<b>0.8</b>	-
Access #2 & Loretta Avenue N Unsignalized	WBL	A	0.04	9.5	0.8	A	0.10	9.5	2.2
	NB	-	-	-	-	-	-	-	-
	SB	A	0.01	7.5	0.0	A	0.01	7.4	0.0
	<b>Overall</b>	<b>A</b>	-	<b>2.0</b>	-	<b>A</b>	-	<b>4.2</b>	-

Notes: Saturation flow rate of 1800 veh/h/lane  
PHF = 1.00

m = metered queue  
# = volume for the 95th %ile cycle exceeds capacity

The access intersection operations for the future total horizon operate well.

### 11.3.2 Access Intersection MMLoS

No signalized intersections are used to access the proposed site.

### 11.3.3 Recommended Design Elements

The recommended access design elements remain consistent with City of Ottawa standards for access design for depressed curbs through the access locations and depressed sidewalks crossing the accesses. The inbound access is noted to be 8.0 metres for truck turning movements.

## 12 Transportation Demand Management

### 12.1 Context for TDM

The mode shares used within the TIA represent the planning level targets for a transit-oriented design (TOD) as the site is located within the Gladstone Station TOD design priority area.

For the residential land use, total bedrooms are estimated to be 1,242 and no age restrictions are noted. The retail and office land uses will be determined by lease options and are entirely dependant on tenants to determine the number and occupation of employees, and clients/customers travelling from the Ottawa-Gatineau area and within 2.0km of the site. It is noted that the existing tenants of the site may continue to stay and rent the provided retail/office space.

### 12.2 Need and Opportunity

The subject site has been assumed to rely predominantly on transit due to the proximity to the future Gladstone LRT Station. The development is planned to coincide with the Corso Italia construction. The convenience of the transit station should provide the opportunity to reach the forecast transit mode share, although incentives for new residential tenants exists within the TDM framework. Hard measures, such as reduced parking provisions, would limit the risk of higher auto mode shares being produced from the site.

### 12.3 TDM Program

The “suite of post occupancy TDM measures” has been summarized in the TDM checklists for both the residential and non-residential land uses. The checklist is provided in Appendix G.

The key TDM measures recommended include:

- Enhanced connectivity of pedestrians and cyclists to the adjacent network and adjacent Gladstone LRT station
- Engagement with local bike share programs (e.g., VeloGO) to include onsite space for bike rack/storage
- Posting of pedestrian, cycling, and transit information and maps at primary entrances/exits
- Unbundle parking cost from purchase or rental costs
- Inclusion of a 1-year Presto card for first time new residential tenants, along with a set time frame for this offer (e.g., 6-months) from the ‘opening’ of the building/tower

The City and the proponent may engage beyond the scope of the TIA process to confirm the elements and conditions required as part of the site plan approvals.

## 13 Neighbourhood Traffic Management

Gladstone Avenue is a major collector road and has a 600-vehicle threshold for two-way traffic volumes per the City’s TIA Guidelines. The existing Gladstone Avenue volumes exceed this threshold in both segments to the east and west of Loretta Avenue N by at least 140 percent. The site traffic will increase the two-way vehicles by 61 to the east of the site and 65 vehicles to the west of the site. The overall increase is not considered significant within the context of the existing Gladstone Avenue traffic. If a reduction is required to meet the TIA thresholds, the City

will be required to explore options to reduce Gladstone Avenue volumes by 250-300 vehicles during the peak hours.

Along Loretta Avenue N, the existing volumes are below the local road thresholds of 120 two-way vehicles. The segment of Loretta Avenue N from Gladstone Avenue to the outbound site access will exceed the local road threshold with the addition of the site traffic and the segment north of the site will remain below the threshold. As the segment between Gladstone Avenue and the site accesses will not have any accesses or adjacent land uses that would be negatively affected by the volumes and no mitigation is recommended. It is noted that the MMLOS analysis meets the area targets for Loretta Avenue N.

## 14 Transit

### 14.1 Route Capacity

In Section 5.1 the trip generation by mode was estimated, including an estimate of the number of transit trips that will be generated by the proposed development. Table 19 summarizes the transit trip generation.

Table 19: Trip Generation by Transit Mode

Travel Mode	Mode Share	AM Peak Period			PM Peak Period		
		In	Out	Total	In	Out	Total
Transit	Varies	157	182	339	124	165	289

The proposed development is anticipated to generate an additional 339 AM peak hour transit trips and 289 PM peak hour transit trips. From the trip distribution found in Section 5.3, these values can further be broken down, and Table summarized the transit ridership by direction and equivalent bus loads.

Table 20: Trip Generation by Transit Mode

Direction	AM Peak Period		PM Peak Period		Service Type	Equivalent Bus Loads
	In	Out	In	Out		
North	8	9	6	8	LRT	-
South	47	55	37	50	LRT	-
East	47	55	37	50	Bus, LRT	A standard bus
West	55	63	44	58	Bus, LRT	A standard bus

The City has indicated that the Trillium line can accommodate the additional ridership demand. If a maximum of 10% of the transit mode share utilizes the existing route #14, this may see the need for an additional single bus (55-person capacity) during the peak hours to accommodate the additional demand.

### 14.2 Transit Priority

No transit priority is required explicitly for this study.

## 15 Network Intersection Design

### 15.1 Network Intersection Control

No change to the existing signalized control is recommended for the network intersections. A signal warrant was completed for the Gladstone Avenue and Loretta Avenue N intersection and is provided in Appendix H.

## 15.2 Network Intersection Design

### 15.2.1 Future Total Network Intersection Operations

The future total network intersection operations are summarized below in Table 21. The level of service for signalized intersections is based on the v/c calculation for individual lane movements and HCM 2000 v/c calculations for the overall intersection, and HCM average delay for unsignalized intersections. The synchro worksheets have been provided in Appendix F.

Table 21: Future Total Network Intersection Operations

Intersection	Lane	AM Peak Hour				PM Peak Hour			
		LOS	V/C	Delay	Q (95th)	LOS	V/C	Delay	Q (95th)
<b>Gladstone Avenue &amp; Preston Street Signalized</b>	EB	C	0.72	36.3	28.0	A	0.58	20.1	51.2
	WBL	A	0.23	21.8	11.5	A	0.23	16.1	16.1
	WBT/R	A	0.55	24.3	38.1	D	0.88	37.3	#123.3
	NBL	A	0.13	9.4	10.5	A	0.32	17.2	17.8
	NBT/R	A	0.50	11.8	66.2	B	0.64	19.7	72.9
	SBL	A	0.19	10.4	12.9	A	0.20	15.0	10.7
	SBT/R	A	0.40	10.9	52.7	A	0.57	18.8	64.4
<b>Overall</b>	<b>A</b>	<b>0.56</b>	<b>17.8</b>	-	-	<b>C</b>	<b>0.75</b>	<b>24.3</b>	-
<b>Gladstone Avenue &amp; Active Mode Crossing Signalized</b>	EB	A	0.17	3.5	16.3	A	0.16	3.5	15.8
	WB	A	0.15	2.0	11.8	A	0.45	2.9	m27.1
	<b>Overall</b>	<b>A</b>	<b>0.16</b>	<b>2.8</b>	-	<b>A</b>	<b>0.42</b>	<b>3.0</b>	-
<b>Gladstone Avenue &amp; Loretta Avenue North Unsignalized</b>	EB	A	0.05	7.9	0.8	A	0.03	9.2	0.1
	WB	A	0.01	7.8	0.0	A	0.01	7.8	0.0
	NB	B	0.03	12.5	0.8	C	0.09	21.5	2.1
	SB	B	0.14	13.7	3.8	D	0.42	25.4	15.0
	<b>Overall</b>	<b>A</b>	-	<b>2.8</b>	-	<b>A</b>	-	<b>3.8</b>	-
<b>Gladstone Avenue &amp; Breezehill Avenue Unsignalized</b>	EB	A	0.02	7.8	0.8	A	0.02	9.1	0.8
	WB	A	0.00	7.9	0.0	A	0.01	7.8	0.0
	NB	B	0.01	11.3	0.0	C	0.02	18.9	0.0
	SB	B	0.07	11.3	1.6	C	0.18	19.9	4.5
	<b>Overall</b>	<b>A</b>	-	<b>1.4</b>	-	<b>A</b>	-	<b>1.4</b>	-
<b>Gladstone Avenue &amp; Bayswater Avenue Signalized</b>	EB	A	0.33	11.7	30.2	A	0.23	8.6	20.1
	WB	A	0.23	9.1	18.7	D	0.82	22.9	#114.3
	NB	A	0.25	13.2	20.6	A	0.47	19.6	37.4
	SB	A	0.37	15.1	29.6	A	0.55	21.3	43.5
	<b>Overall</b>	<b>A</b>	<b>0.34</b>	<b>12.3</b>	-	<b>C</b>	<b>0.71</b>	<b>19.9</b>	-
<b>Somerset Street W &amp; Breezehill Avenue Unsignalized</b>	EB	-	-	-	-	-	-	-	-
	WB	A	0.01	8.1	0.0	A	0.02	8.6	1.5
	NB	B	0.08	12.2	2.1	C	0.13	17.0	3.0
	<b>Overall</b>	<b>A</b>	-	<b>1.1</b>	-	<b>A</b>	-	<b>1.1</b>	-
<b>Laurel Street &amp; Breezehill Avenue Unsignalized</b>	EB	A	0.06	7.5	1.5	A	0.04	7.3	0.8
	WB	A	0.03	7.3	0.8	A	0.05	7.3	1.5
	NB	A	0.08	7.5	2.1	A	0.06	7.5	1.5
	SB	A	0.09	7.5	2.1	A	0.09	7.3	2.1
	<b>Overall</b>	<b>A</b>	-	<b>7.5</b>	-	<b>A</b>	-	<b>7.3</b>	-

Notes: Saturation flow rate of 1800 veh/h/lane  
PHF = 1.00

m = metered queue  
# = volume for the 95th %ile cycle exceeds capacity

The network intersection operations for the future total conditions operate similarly to the existing conditions. A slight increase in operations is noted due to the peak hour factor of 1.00 applied when compared to the existing conditions.

15.2.2 Network Intersection MMLOS

Table 22 summarizes the MMLOS analysis for the signalized network intersections and the existing and future conditions for are assumed to be the same and are considered in one row. The intersection analysis is based on the policy area of “within 600m of a rapid transit station”, which has the same targets as “within 330m of a school”. The MMLOS worksheets has been provided in Appendix E.

Table 22: Study Area Intersection MMLOS Analysis

Intersection	Pedestrian LOS		Bicycle LOS		Transit LOS		Truck LOS		Auto LOS	
	PLOS	Target	BLOS	Target	TLOS	Target	TrLOS	Target	ALOS	Target
Gladstone Avenue & Preston Street	E	A	D	B	E	D	E	D	C	E
Gladstone Avenue & Bayswater Avenue	D	A	B	B	D	D	-	-	C	E

The MMLOS targets will not be met for the pedestrian at both intersections and bicycle LOS, transit LOS, and truck LOS at the Gladstone Avenue and Preston Street intersection.

To meet the PLOS targets, the intersection of Gladstone Avenue and Bayswater Avenue could meet the area targets on the east and west sides of the intersection with a signage change to prohibit right-turns on red, and on the north and south sides of the intersection through protected left-turns on Gladstone Avenue or a combination of zebra hi-vis crossing markings and the prohibition of right-turns on red. These are considered City improvements and can be reviewed internally for potential implementation.

At the intersection of Gladstone Avenue and Preston Street, the PLOS cannot be met due to arterial road intersection limitations. It would require reconstruction of the intersection to reduce all pedestrian crossing distances to approximately 7.0 metres and include the additional implementation of on of the following items: protected left-turns, right-turn on red prohibition or raised pedestrian crossings. The bicycle LOS would require operating speed to be reduced to less than 40 km/h, the transit LOS would require delay to be reduced to below 30 seconds on all transit approach movements, and the truck LOS would require additional receiving lanes or corner radii to be increased to greater than 15 metres to meet the targets. No improvements are recommended for this intersection to meet the MMLOS targets.

15.2.3 Recommended Design Elements

No study area intersection design elements are proposed as part of this study.

16 Summary of Improvements Indicated and Modifications Options

The following summarizes the analysis and results presented in this TIA report:

Proposed Site and Screening

- The proposed site includes 849 residential units, 193,015 sq. ft of office space (including live-work space), and 17,611 sq. ft. of retail space (including the existing Standard Bread building)
- Accesses will be provided along Loretta Avenue N, with a two-way access and a one-way outbound loop to the north, with the Tower 3 garbage/loading access located separately to the north end of the site

- A pedestrian plaza is proposed at the corner of the development adjacent to Gladstone Avenue and the Trillium LRT corridor
- The development is proposed to be completed by 2026
- The trip generation and location triggers were met for the TIA Screening

### **Existing Conditions**

- Preston Street and Somerset Street W are arterial roads, Gladstone Avenue is a major collector road, and Bayswater Avenue is a collector road in the study area
- Sidewalks are generally provided on both sides of the study area roadways, with the exception of limited facilities along Loretta Avenue, no sidewalks on Laurel Street to the east of Breezehill Avenue and on the east side of Breezehill Avenue between Laurel Street and Gladstone Avenue
- Bike lanes are provided on Somerset Street W over the Trillium LRT corridor and Gladstone Avenue, Bayswater Avenue and Somerset Street W are suggested bike routes
- The Trillium Pathway runs along the east side of the Trillium LRT corridor
- The existing transit route #14 travels along Gladstone Avenue, route #11 along Somerset Street W and #85 along Preston Street
- No operational issues are noted for the study area intersections
- The study area intersections with higher collisions were reviewed and no specific mitigation recommendations are noted for the Gladstone Avenue and Bayswater Avenue intersection or Gladstone Avenue and Preston Street intersection, but additional review may be required by the City for Somerset Street W between Breezehill Avenue and Preston Street for cycling collisions

### **Development Generated Travel Demand**

- The proposed development is forecasted produce 616 two-way people trips during the AM peak period and 647 two-way people trips during the PM peak period
- Of the forecasted people trips, 136 two-way trips will be vehicle trips during the AM peak hour and 149 two-way trips will be vehicle trips during the PM peak hour
- Of the forecasted people trips, 339 two-way trips will be transit trips during the AM peak hour and 289 two-way trips will be transit trips during the PM peak hour
- Of the forecasted trips, 35% are anticipated to travel west, 30 to the east and south, and 5% to the north

### **Background Conditions**

- Adjacent developments have either been on hold for extended periods of time with an unknown horizon, or are too small to have a noticeable impact on the adjacent road network
- Additionally, the background growth in the Ottawa core has been decreasing and a 0% growth was assumed for the area
- The future background intersection operations are the same as the existing intersections

### **Development Design**

- The auto parking areas are to be located in two levels of underground parking and the bike parking will be internal to the building
- Pedestrian connections will be made along Gladstone Avenue and Loretta Avenue N, and a connection to the Trillium LRT corridor MUP will be made between Towers 2 and 3 and at the Gladstone Avenue pedestrian plaza to the LRT station

- Site access are compliant with the Private Approach By-Law

### **Parking**

- The site is proposed to provide a total of 560 parking spaces, split into 30 visitor spaces, 423 residential spaces, 91 office/live-work spaces and 16 retail parking spaces
- In addition, 423 bicycle parking spaces will be provided for the residential component and 80 bicycle spaces for the retail, office, and live-work components

### **Boundary Street Design**

- The boundary streets will not meet pedestrian MMLOS targets along Gladstone Avenue and the existing Loretta Avenue N, due to auto volumes and lack of boulevard space along Gladstone Avenue and no sidewalk currently provided along the frontage of Loretta Avenue N
- The addition of the sidewalk and boulevard on Loretta Avenue N will meet the pedestrian targets once the site is developed
- Gladstone Avenue segment do not meet the bicycle MMLOS target, which requires reduction of operating speed to be less or equal to 40 km/h

### **Access Intersections Design**

- A one-way loop access and garbage/move-in only access are proposed along Loretta Avenue N, the access will require a depressed curb and sidewalk through the access
- The outbound access will include a minor stop control and one-way signage will be provided on both the inbound and outbound accesses of the one-way loop
- No specific recommendations or design elements are required outside of typical site design

### **TDM**

- Supportive TDM measures to be included within the proposed development should include:
  - Enhanced connectivity of pedestrians and cyclists to the adjacent network and adjacent Gladstone LRT station
  - Engagement with local bike share programs (e.g., VeloGO) to include onsite space for bike rack/storage
  - Posting of pedestrian, cycling, and transit information and maps at primary entrances/exits
  - Unbundle parking cost from purchase or rental costs
  - Inclusion of a 1-year Presto card for first time new residential tenants, along with a set time frame for this offer (e.g., 6-months) from the 'opening' of the building/tower
- The City and the proponent may engage beyond the scope of the TIA process to confirm the elements and conditions required as part of the site plan approvals

### **Neighbourhood Traffic Management**

- Gladstone Avenue currently exceeds the City's TIA Guideline thresholds for a major collector road, and the City would be required to reduce the two-way traffic along Gladstone Avenue by 250-300 vehicles during the peak hours to achieve the prescribed thresholds
- Loretta Avenue N is currently under the City's TIA Guideline thresholds for a local road and is projected to remain under the threshold to the north upon the site build-out

- Between Gladstone Avenue and the outbound access of the one-way loop is forecasted to exceed the City's TIA Guideline thresholds for a local road, and due to limited impacts along the segment, no mitigation is recommended

#### Transit

- The City has confirmed the forecasted transit use/ridership can be accommodated on the Trillium LRT line
- An additional bus in each direction may be needed along Gladstone Avenue may be required during the peak hours for local routes
- No specific transit priority measures were considered as part of this development

#### Network Intersection Design

- Generally, the network intersections will operate similarly to the existing conditions
- The MMLOS targets will not be met for the pedestrian LOS at the Gladstone Avenue intersections at Bayswater Avenue and at Preston Street, the transit LOS and truck LOS at Preston Street
- At the intersection of Gladstone Avenue and Bayswater Avenue, the prohibition of right-turns on read for all approaches and the addition of zebra hi-vis crossing markings on the north and south sides of the intersection would be required to meet the pedestrian LOS, and are considered the responsibility of the City to implement should they require
- The bicycle LOS would require operating speed to be reduced to less than 40 km/h at the intersection of Gladstone Avenue and Preston Street
- The transit LOS would require delay to be reduced to below 30 seconds on all transit approach movements, and the truck LOS would require additional receiving lanes or corner radii to be increased to greater than 15 metres at the intersection of Gladstone Avenue and Preston Street
- No mitigation is recommended for the Gladstone Avenue and Preston Street intersection as reconstruction would be required to meet the pedestrian LOS targets and the truck LOS targets directly conflict with achieving the pedestrian LOS targets

## 17 Conclusion

It is recommended that, from a transportation perspective, the proposed development applications proceed.

Prepared By:

Reviewed By:



Andrew Harte, P.Eng.  
Senior Transportation Engineer

Christopher Gordon, P.Eng.  
Senior Transportation Engineer

# Appendix A

TIA Screening Form and PM Certification Form

City of Ottawa 2017 TIA Guidelines  
Step 1 - Screening Form

Date: 08-Apr-21  
Project Number: 2020-25  
Project Reference: 951 Gladstone & 145 Loretta

1.1 Description of Proposed Development	
Municipal Address	951 Gladstone Ave, 145 Loretta Ave N
Description of Location	Existing general industrial or retail/commercial uses, including the Standard Bread Building
Land Use Classification	Pending rezoning to Mixed-Use Centre
Development Size	Apartments: 843 units, Office: 198,165 sq. ft, Retail: 17,611 sq.ft (includes Standard Bread Building)
Accesses	One-way loop and garbage/move-in access on Loretta
Phase of Development	Single Phase
Buildout Year	2026
TIA Requirement	Full TIA Required

1.2 Trip Generation Trigger	
Land Use Type	Townhomes or apartments
Development Size	843 Units
Trip Generation Trigger	Yes

1.3 Location Triggers	
Does the development propose a new driveway to a boundary street that is designated as part of the City's Transit Priority, Rapid Transit or Spine Bicycle Networks?	No
Is the development in a Design Priority Area (DPA) or Transit-oriented Development (TOD) zone?	Yes
Location Trigger	Yes

1.4. Safety Triggers	
Are posted speed limits on a boundary street 80 km/hr or greater?	No
Are there any horizontal/vertical curvatures on a boundary street limits sight lines at a proposed driveway?	No
Is the proposed driveway within the area of influence of an adjacent traffic signal or roundabout (i.e. within 300 m of intersection in rural conditions, or within 150 m of intersection in urban/ suburban conditions)?	No
Is the proposed driveway within auxiliary lanes of an intersection?	No
Does the proposed driveway make use of an existing median break that serves an existing site?	No
Is there is a documented history of traffic operations or safety concerns on the boundary streets within 500 m of the development?	No
Does the development include a drive-thru facility?	No
Safety Trigger	No



## **TIA Plan Reports**

On 14 June 2017, the Council of the City of Ottawa adopted new Transportation Impact Assessment (TIA) Guidelines. In adopting the guidelines, Council established a requirement for those preparing and delivering transportation impact assessments and reports to sign a letter of certification.

Individuals submitting TIA reports will be responsible for all aspects of development-related transportation assessment and reporting, and undertaking such work, in accordance and compliance with the City of Ottawa's Official Plan, the Transportation Master Plan and the Transportation Impact Assessment (2017) Guidelines.

By submitting the attached TIA report (and any associated documents) and signing this document, the individual acknowledges that s/he meets the four criteria listed below.

### **CERTIFICATION**

1. I have reviewed and have a sound understanding of the objectives, needs and requirements of the City of Ottawa's Official Plan, Transportation Master Plan and the Transportation Impact Assessment (2017) Guidelines;
2. I have a sound knowledge of industry standard practice with respect to the preparation of transportation impact assessment reports, including multi modal level of service review;
3. I have substantial experience (more than 5 years) in undertaking and delivering transportation impact studies (analysis, reporting and geometric design) with strong background knowledge in transportation planning, engineering or traffic operations; and
4. I am either a licensed<sup>1</sup> or registered<sup>2</sup> professional in good standing, whose field of expertise [check  appropriate field(s)] is either transportation engineering  or transportation planning .

**1,2 License of registration body that oversees the profession is required to have a code of conduct and ethics guidelines that will ensure appropriate conduct and representation for transportation planning and/or transportation engineering works.**

City Of Ottawa  
Infrastructure Services and Community  
Sustainability  
Planning and Growth Management  
110 Laurier Avenue West, 4th fl.  
Ottawa, ON K1P 1J1  
Tel. : 613-580-2424  
Fax: 613-560-6006

Ville d'Ottawa  
Services d'infrastructure et Viabilité des  
collectivités  
Urbanisme et Gestion de la croissance  
110, avenue Laurier Ouest  
Ottawa (Ontario) K1P 1J1  
Tél. : 613-580-2424  
Télécopieur: 613-560-6006

Dated at Ottawa this 20 day of September, 2018.  
(City)

Name: Andrew Harte  
(Please Print)

Professional Title: Professional Engineer

  
\_\_\_\_\_  
Signature of Individual certifier that s/he meets the above four criteria

<b>Office Contact Information (Please Print)</b>
Address: 13 Markham Avenue
City / Postal Code: Ottawa / K2G 3Z1
Telephone / Extension: (613) 697-3797
E-Mail Address: Andrew.Harte@CGHTransportation.com



# Appendix B

Turning Movement Count Data



**Turning Movement Count - 15 Minute Summary Report**

**BAYSWATER AVE @ GLADSTONE AVE**

Survey Date: Wednesday, July 27, 2016

Total Observed U-Turns

Northbound: 0 Southbound: 0  
Eastbound: 0 Westbound: 0

Time Period	BAYSWATER AVE								GLADSTONE AVE								Grand Total		
	Northbound				Southbound				Eastbound				Westbound						
	LT	ST	RT	N TOT	LT	ST	RT	S TOT	STR TOT	LT	ST	RT	E TOT	LT	ST	RT		W TOT	STR TOT
07:00 07:15	0	13	3	16	11	31	6	48	64	5	22	3	30	2	11	6	19	49	113
07:15 07:30	2	21	2	25	3	23	3	29	54	5	21	3	29	2	18	5	25	54	108
07:30 07:45	1	19	2	22	10	32	2	44	66	9	24	3	36	3	21	8	32	68	134
07:45 08:00	2	25	7	34	8	35	5	48	82	5	26	3	36	4	14	4	22	58	140
08:00 08:15	3	20	5	28	18	30	11	59	87	5	30	1	42	3	19	7	29	71	158
08:15 08:30	5	32	3	40	8	29	7	44	84	7	28	4	39	1	22	9	32	71	155
08:30 08:45	3	24	7	34	10	32	15	57	91	5	23	8	36	5	26	10	41	77	166
08:45 09:00	8	30	7	45	14	33	4	51	96	6	25	3	34	5	38	9	52	86	182
09:00 09:15	3	27	8	38	9	24	7	40	78	7	28	3	38	5	19	8	32	70	148
09:15 09:30	4	18	10	32	10	28	9	47	79	3	29	2	34	2	20	8	30	64	143
09:30 09:45	7	13	8	28	10	14	5	29	57	6	23	5	34	3	21	7	31	65	122
09:45 10:00	4	12	5	21	9	19	2	30	51	5	24	3	32	1	25	6	32	64	115
11:30 11:45	4	28	5	37	2	21	5	28	65	2	27	2	31	12	24	10	46	77	142
11:45 12:00	5	15	14	34	10	23	6	39	73	1	30	3	34	5	46	14	65	99	172
12:00 12:15	6	25	9	40	8	28	8	44	84	5	28	0	33	7	35	8	50	83	167
12:15 12:30	6	17	5	28	8	23	13	44	72	4	26	4	34	6	38	15	59	93	165
12:30 12:45	7	28	10	45	5	18	3	26	71	8	29	4	41	3	27	8	38	77	148
12:45 13:00	7	27	13	47	10	15	4	29	76	3	26	5	34	7	28	10	45	79	155
13:00 13:15	3	14	3	20	7	24	4	35	55	4	30	3	37	4	32	16	52	89	144
13:15 13:30	5	20	8	33	10	17	4	31	64	9	33	4	46	2	38	10	50	96	160
15:00 15:15	4	48	5	57	10	30	9	49	106	6	32	3	41	7	27	11	45	86	192
15:15 15:30	2	53	3	58	6	42	8	56	114	8	20	8	36	9	35	28	70	106	220
15:30 15:45	1	52	7	60	4	38	2	44	104	7	28	2	37	11	60	35	106	143	247
15:45 16:00	4	46	5	55	8	25	6	39	94	5	25	5	35	9	40	23	78	113	207
16:00 16:15	6	57	7	70	12	35	10	57	127	11	30	6	47	13	69	33	115	162	289
16:15 16:30	7	44	3	54	9	47	9	65	119	8	26	1	35	24	66	27	117	152	271
16:30 16:45	8	44	8	60	5	69	9	83	143	7	26	8	41	11	66	32	109	150	293
16:45 17:00	8	37	10	55	9	55	6	70	125	4	18	3	25	26	66	22	114	139	264
17:00 17:15	9	40	2	51	6	58	15	79	130	9	26	6	41	22	57	27	106	147	277
17:15 17:30	5	36	10	51	9	37	12	58	109	9	23	6	38	16	73	26	115	153	262
17:30 17:45	3	28	5	36	6	35	8	49	85	11	29	5	45	11	50	13	74	119	204
17:45 18:00	6	26	9	41	10	28	10	48	89	6	21	2	29	5	38	11	54	83	172
<b>TOTAL:</b>	<b>148</b>	<b>939</b>	<b>208</b>	<b>1295</b>	<b>274</b>	<b>998</b>	<b>227</b>	<b>1499</b>	<b>2794</b>	<b>195</b>	<b>844</b>	<b>121</b>	<b>1160</b>	<b>246</b>	<b>1175</b>	<b>462</b>	<b>1883</b>	<b>3043</b>	<b>5837</b>

Note: U-Turns are included in Totals.

Comment:



**BAYSWATER AVE @ GLADSTONE AVE**

Count Date: Wednesday, July 27, 2016

Start Time: 07:00

Time Period	BAYSWATER AVE			GLADSTONE AVE			Grand Total
	Northbound	Southbound	Street Total	Eastbound	Westbound	Street Total	
07:00 08:00	6	2	8	29	14	43	51
08:00 09:00	12	7	19	63	18	81	100
09:00 10:00	5	0	5	19	15	34	39
11:30 12:30	2	0	2	11	14	25	27
12:30 13:30	2	0	2	10	0	10	12
15:00 16:00	3	4	7	10	9	19	26
16:00 17:00	3	7	10	21	51	72	82
17:00 18:00	11	11	22	35	40	75	97
<b>Total</b>	<b>44</b>	<b>31</b>	<b>75</b>	<b>198</b>	<b>161</b>	<b>359</b>	<b>434</b>

Comment:

Note: These volumes consists of bicycles only (no mopeds or motorcycles) and ARE NOT included in the Turning Movement Count Summary.



Transportation Services - Traffic Services  
Turning Movement Count - Full Study Diagram

BAYSWATER AVE @ GLADSTONE AVE

Survey Date: Wednesday, July 27, 2016

WO#: 36100  
Device: Miovision

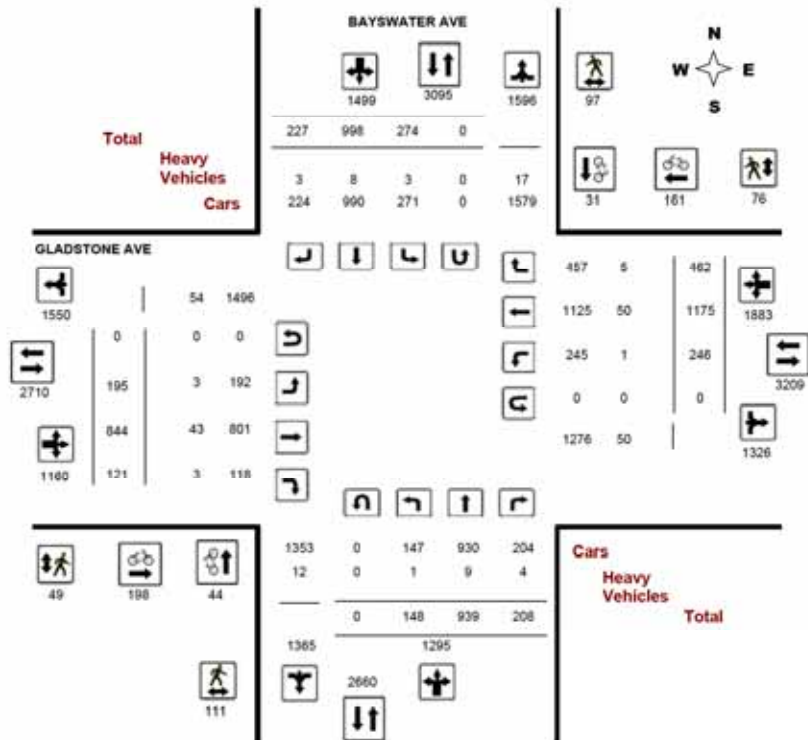

Comments



Transportation Services - Traffic Services

W.O.  
36100

Turning Movement Count - Heavy Vehicle Report

BAYSWATER AVE @ GLADSTONE AVE

Survey Date: Wednesday, July 27, 2016

Time Period	BAYSWATER AVE							GLADSTONE AVE							W TOT	STR TOT	Grand Total		
	Northbound			Southbound				Eastbound			Westbound								
	LT	ST	RT	N TOT	LT	ST	RT	S TOT	STR TOT	LT	ST	RT	E TOT	LT				ST	RT
07:00-08:00	0	0	1	1	1	1	0	2	3	2	2	0	4	1	8	0	9	13	16
08:00-09:00	0	2	0	2	0	3	1	4	6	0	4	2	6	0	7	1	8	14	20
09:00-10:00	0	1	0	1	0	1	0	1	2	0	4	0	4	0	5	0	5	9	11
11:30-12:30	0	1	3	4	1	0	1	2	6	0	6	0	6	0	8	2	10	16	22
12:30-13:30	1	5	0	6	1	2	0	3	9	0	9	1	10	0	9	0	9	19	28
15:00-16:00	0	0	0	0	0	0	0	0	0	0	9	0	9	0	3	2	5	14	14
16:00-17:00	0	0	0	0	0	0	1	1	1	1	6	0	7	0	6	0	6	13	14
17:00-18:00	0	0	0	0	0	1	0	1	1	0	3	0	3	0	4	0	4	7	8
<b>Sub Total</b>	<b>1</b>	<b>9</b>	<b>4</b>	<b>14</b>	<b>3</b>	<b>6</b>	<b>3</b>	<b>14</b>	<b>28</b>	<b>3</b>	<b>43</b>	<b>3</b>	<b>49</b>	<b>1</b>	<b>50</b>	<b>5</b>	<b>56</b>	<b>105</b>	<b>133</b>
<b>U-Turns (Heavy Vehicles)</b>	<b>0</b>	<b>0</b>	<b>0</b>	<b>0</b>	<b>0</b>	<b>0</b>	<b>0</b>	<b>0</b>	<b>0</b>	<b>0</b>	<b>0</b>	<b>0</b>	<b>0</b>	<b>0</b>	<b>0</b>	<b>0</b>	<b>0</b>	<b>0</b>	<b>0</b>
<b>Total</b>	<b>1</b>	<b>9</b>	<b>4</b>	<b>14</b>	<b>3</b>	<b>6</b>	<b>3</b>	<b>14</b>	<b>28</b>	<b>3</b>	<b>43</b>	<b>3</b>	<b>49</b>	<b>1</b>	<b>50</b>	<b>5</b>	<b>56</b>	<b>105</b>	<b>133</b>

Heavy Vehicles include Buses, Single-Unit Trucks and Articulated Trucks. Further, they ARE included in the Turning Movement Count Summary.



# Transportation Services - Traffic Services

Work Order  
36100

## Turning Movement Count - Pedestrian Volume Report

### BAYSWATER AVE @ GLADSTONE AVE

Count Date: Wednesday, July 27, 2016

Start Time: 07:00

Time Period	NB Approach (E or W Crossing)	SB Approach (E or W Crossing)	Total	EB Approach (N or S Crossing)	WB Approach (N or S Crossing)	Total	Grand Total
07:00 07:15	1	1	2	0	1	1	3
07:15 07:30	3	0	3	1	0	1	4
07:30 07:45	4	5	9	2	1	3	12
07:45 08:00	3	3	6	1	6	7	13
07:00 08:00	11	9	20	4	8	12	32
08:00 08:15	2	5	7	1	3	4	11
08:15 08:30	5	6	11	1	4	5	16
08:30 08:45	8	2	10	0	0	0	10
08:45 09:00	1	5	6	1	1	2	8
08:00 09:00	16	18	34	3	6	11	45
09:00 09:15	3	5	8	2	0	2	10
09:15 09:30	2	2	4	1	2	3	7
09:30 09:45	4	3	7	2	2	4	11
09:45 10:00	2	1	3	0	3	3	6
09:00 10:00	11	11	22	5	7	12	34
11:30 11:45	1	4	5	0	1	1	6
11:45 12:00	3	0	3	0	4	4	7
12:00 12:15	3	0	3	0	0	0	3
12:15 12:30	4	1	5	2	1	3	8
11:30 12:30	11	5	16	2	5	7	23
12:30 12:45	3	0	3	2	1	3	6
12:45 13:00	5	1	6	0	0	0	6
13:00 13:15	4	1	5	0	2	2	7
13:15 13:30	5	2	7	1	3	4	11
12:30 13:30	17	4	21	3	6	9	30
15:00 15:15	0	1	1	0	1	1	2
15:15 15:30	3	1	4	4	2	6	10
15:30 15:45	4	2	6	1	2	3	9
15:45 16:00	2	2	4	0	3	3	7
15:00 16:00	9	6	15	5	8	13	28
16:00 16:15	6	9	15	3	4	7	22
16:15 16:30	2	1	3	4	0	4	7
16:30 16:45	8	7	15	5	5	10	25
16:45 17:00	11	6	17	1	2	3	20
16:00 17:00	27	23	50	13	11	24	74
17:00 17:15	3	8	11	3	1	4	15
17:15 17:30	1	7	8	3	7	10	18
17:30 17:45	2	3	5	2	5	7	12
17:45 18:00	3	3	6	6	0	6	12
17:00 18:00	9	21	30	14	13	27	57
Total	111	97	208	49	76	125	333

Comment:



# Transportation Services - Traffic Services

Work Order  
36100

## Turning Movement Count - Full Study Summary Report

### BAYSWATER AVE @ GLADSTONE AVE

Survey Date: Wednesday, July 27, 2016

Total Observed U-Turns

AADT Factor

Northbound: 0      Southbound: 0  
Eastbound: 0      Westbound: 0

.90

#### Full Study

Period	BAYSWATER AVE						GLADSTONE AVE						WB TOT	STR TOT	Grand Total					
	Northbound			Southbound			Eastbound			Westbound										
	LT	ST	RT	NB TOT	LT	ST	RT	SB TOT	STR TOT	LT	ST	RT				EB TOT	LT	ST	RT	
07:00 08:00	5	78	14	97	32	121	16	169	266	24	95	12	131	11	64	23	98	229	495	
08:00 09:00	19	108	22	147	50	124	37	211	358	23	112	16	151	14	105	35	154	305	663	
09:00 10:00	18	70	31	119	38	85	23	148	265	21	104	13	138	11	85	29	125	263	528	
11:30 12:30	21	85	33	139	28	95	32	155	294	12	111	9	132	30	143	47	220	352	646	
12:30 13:30	22	89	34	145	32	74	15	121	266	24	118	16	158	16	125	42	183	341	607	
15:00 16:00	11	199	20	230	28	135	25	188	418	26	105	18	149	36	168	95	299	448	866	
16:00 17:00	29	182	28	239	35	206	34	275	514	30	100	18	148	74	267	114	455	603	1117	
17:00 18:00	23	130	26	179	31	158	45	234	413	35	99	19	153	54	218	77	349	502	915	
Sub Total	148	939	208	1295	274	998	227	1499	2794	195	844	121	1160	246	1175	462	1883	3043	5837	
U Turns				0				0	0				0					0	0	0
Total	148	939	208	1295	274	998	227	1499	2794	195	844	121	1160	246	1175	462	1883	3043	5837	
EQ 12hr	206	1305	289	1800	381	1387	316	2084	3884	271	1173	168	1612	342	1833	642	2617	4229	8113	
Note: These values are calculated by multiplying the totals by the appropriate expansion factor.													1.39							
AVG 12hr	185	1175	260	1620	343	1248	284	1875	3495	244	1056	151	1451	308	1470	578	2356	3807	7302	
Note: These volumes are calculated by multiplying the Equivalent 12 hr. totals by the AADT factor.													.90							
AVG 24hr	243	1539	341	2122	449	1836	372	2457	4579	320	1353	198	1981	403	1926	757	3086	4987	9566	
Note: These volumes are calculated by multiplying the Average Daily 12 hr. totals by 12 to 24 expansion factor.													1.31							

#### Comments:

Note: U-Turns provided for approach totals. Refer to 'U-Turn' Report for specific breakdown.



### Transportation Services - Traffic Services

#### Turning Movement Count - Peak Hour Diagram

#### BAYSWATER AVE @ GLADSTONE AVE

Survey Date: Wednesday, July 27, 2016

Start Time: 07:00

WO No: 36100

Device: Miovision

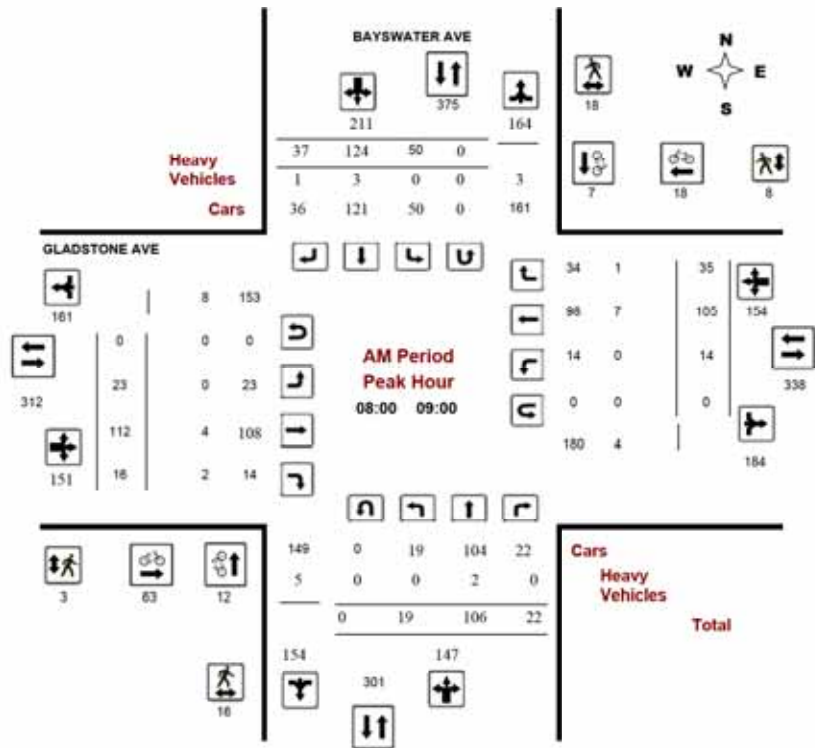

Comments



### Transportation Services - Traffic Services

#### Turning Movement Count - Peak Hour Diagram

#### BAYSWATER AVE @ GLADSTONE AVE

Survey Date: Wednesday, July 27, 2016

Start Time: 07:00

WO No: 36100

Device: Miovision

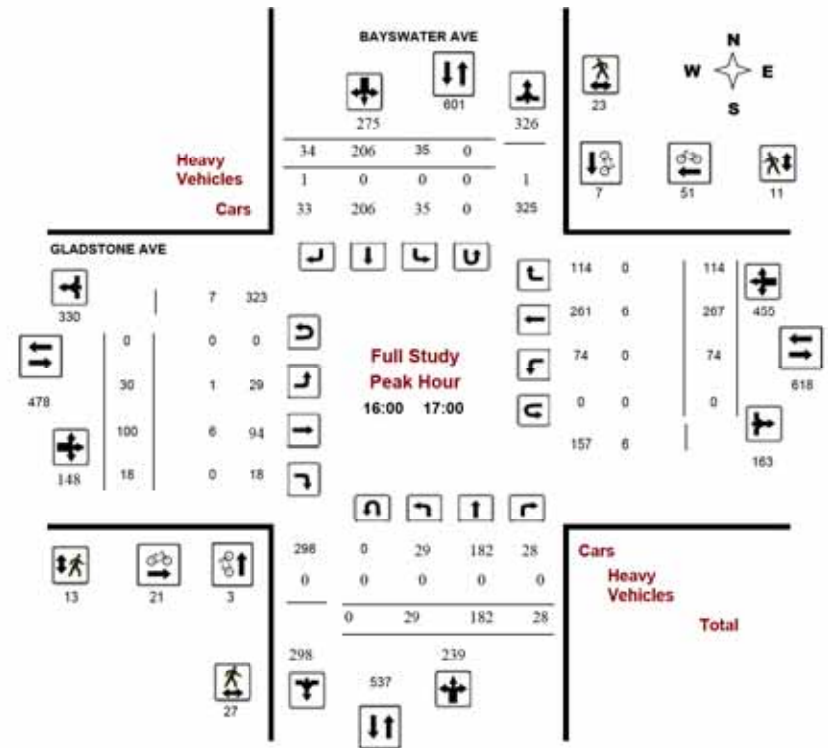

Comments



### Transportation Services - Traffic Services

#### Turning Movement Count - Peak Hour Diagram

#### BAYSWATER AVE @ GLADSTONE AVE

Survey Date: Wednesday, July 27, 2016

Start Time: 07:00

WO No: 36100

Device: Miovision

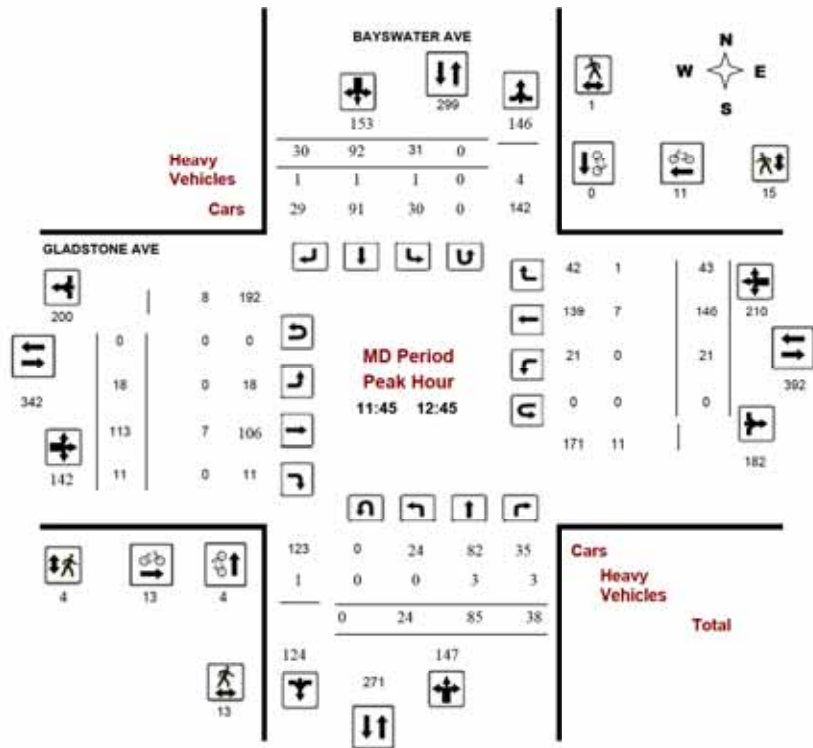

### Transportation Services - Traffic Services

#### Turning Movement Count - Peak Hour Diagram

#### BAYSWATER AVE @ GLADSTONE AVE

Survey Date: Wednesday, July 27, 2016

Start Time: 07:00

WO No: 36100

Device: Miovision

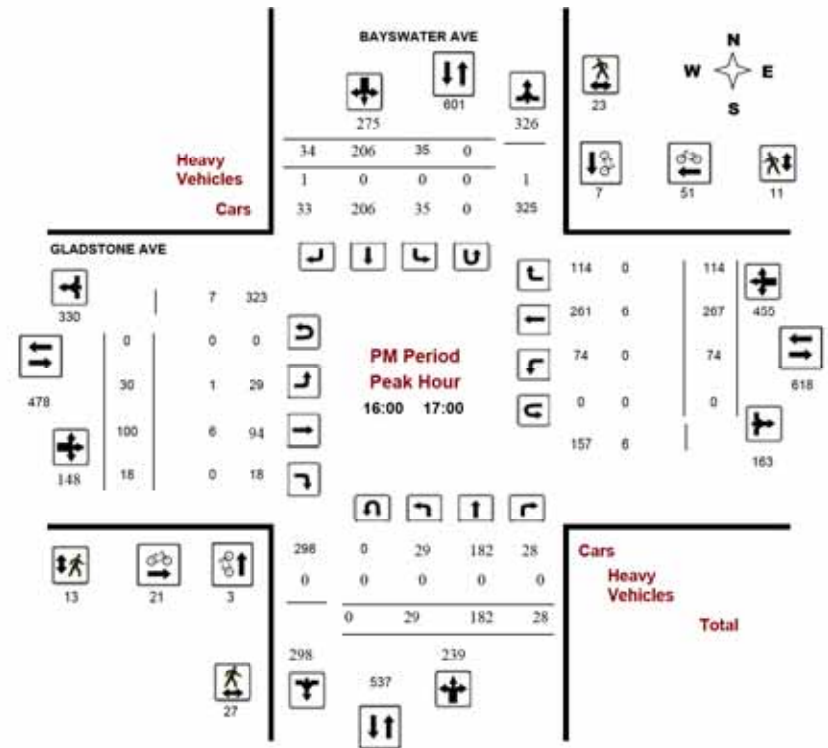



Turning Movement Count - 15 Min U-Turn Total Report

BAYSWATER AVE @ GLADSTONE AVE

Survey Date: Wednesday, July 27, 2016

Time Period	Northbound U-Turn Total	Southbound U-Turn Total	Eastbound U-Turn Total	Westbound U-Turn Total	Total
07:00 - 07:15	0	0	0	0	0
07:15 - 07:30	0	0	0	0	0
07:30 - 07:45	0	0	0	0	0
07:45 - 08:00	0	0	0	0	0
08:00 - 08:15	0	0	0	0	0
08:15 - 08:30	0	0	0	0	0
08:30 - 08:45	0	0	0	0	0
08:45 - 09:00	0	0	0	0	0
09:00 - 09:15	0	0	0	0	0
09:15 - 09:30	0	0	0	0	0
09:30 - 09:45	0	0	0	0	0
09:45 - 10:00	0	0	0	0	0
11:30 - 11:45	0	0	0	0	0
11:45 - 12:00	0	0	0	0	0
12:00 - 12:15	0	0	0	0	0
12:15 - 12:30	0	0	0	0	0
12:30 - 12:45	0	0	0	0	0
12:45 - 13:00	0	0	0	0	0
13:00 - 13:15	0	0	0	0	0
13:15 - 13:30	0	0	0	0	0
15:00 - 15:15	0	0	0	0	0
15:15 - 15:30	0	0	0	0	0
15:30 - 15:45	0	0	0	0	0
15:45 - 16:00	0	0	0	0	0
16:00 - 16:15	0	0	0	0	0
16:15 - 16:30	0	0	0	0	0
16:30 - 16:45	0	0	0	0	0
16:45 - 17:00	0	0	0	0	0
17:00 - 17:15	0	0	0	0	0
17:15 - 17:30	0	0	0	0	0
17:30 - 17:45	0	0	0	0	0
17:45 - 18:00	0	0	0	0	0
Total	0	0	0	0	0



Turning Movement Count  
Summary, AM and PM Peak Hour  
Flow Diagrams

Automobiles, Taxis, Light Trucks, Vans, SUV's, Motorcycles, Heavy Trucks, Buses, and School Buses

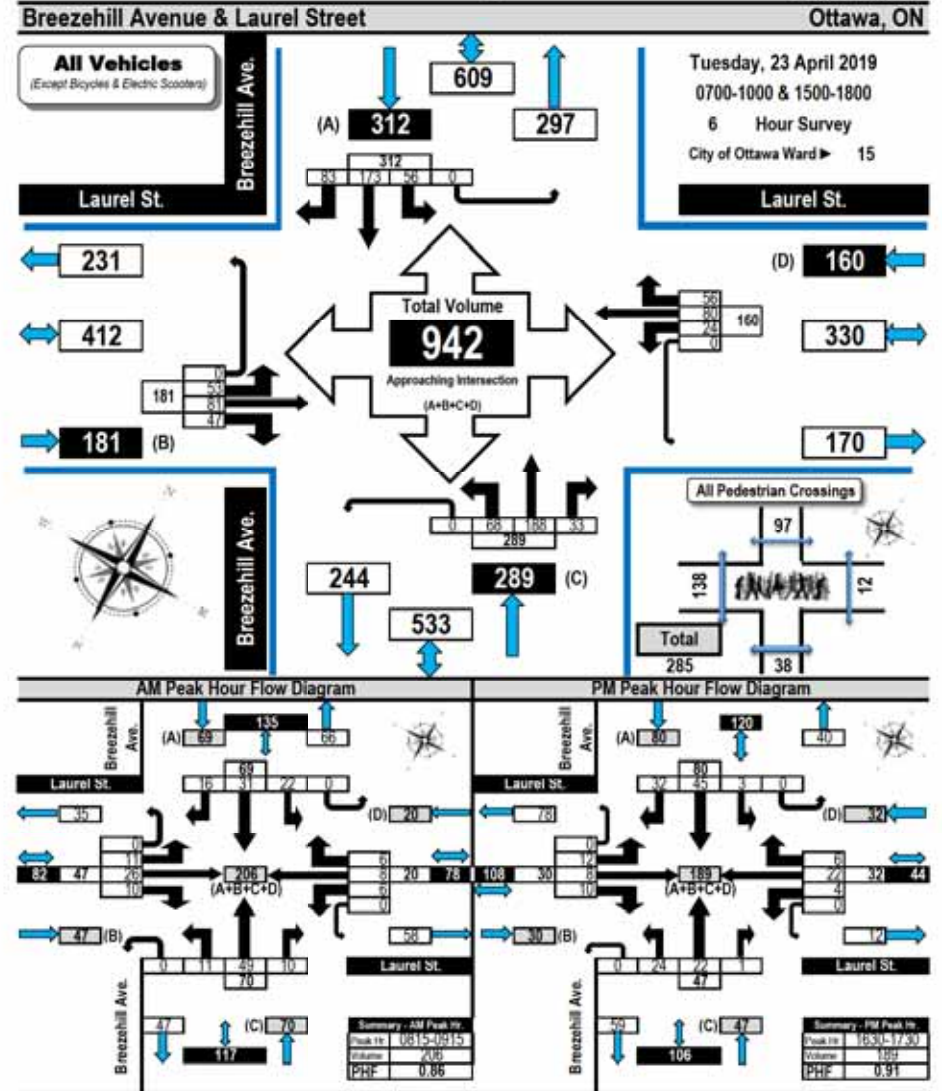



## Turning Movement Count Summary Report AADT and Expansion Factors

Automobiles, Taxis,  
Light Trucks, Vans,  
SUV's, Motorcycles,  
Heavy Trucks, Buses,  
and School Buses

### Breezhill Avenue & Laurel Street Ottawa, ON

Survey Date: Tuesday, 23 April 2019 Start Time: 0700 AADT Factor: 0.7  
Weather AM: Partly Cloudy +10°C Survey Duration: 6 Hrs. Survey Hours: 0700-1000 & 1500-1800  
Weather PM: Overcast +17°C Surveyor(s): Carmody

Time Period	Laurel St. Eastbound				Laurel St. Westbound				Breezhill Ave. Northbound				Breezhill Ave. Southbound				Street Total	Grand Total					
	LT	ST	RT	UT	LT	ST	RT	UT	LT	ST	RT	UT	LT	ST	RT	UT							
	E/B Tot				W/B Tot				N/B Tot				S/B Tot										
0700-0800	4	16	4	0	24	2	5	7	0	14	38	7	26	7	0	40	10	17	2	0	29	69	107
0800-0900	12	19	5	0	36	6	8	11	0	25	61	12	44	9	0	65	15	36	18	0	69	134	195
0900-1000	12	19	11	0	42	4	11	10	0	25	67	4	39	8	0	51	14	21	9	0	44	95	162
1500-1600	4	9	12	0	25	0	19	10	0	41	66	14	29	0	0	49	0	29	0	0	45	94	160
1600-1700	12	11	10	0	33	4	19	7	0	30	63	9	27	0	0	36	6	33	18	0	57	93	156
1700-1800	9	7	5	0	21	2	18	5	0	25	46	22	23	3	0	48	3	37	28	0	68	116	162
Totals	53	81	47	0	181	24	80	56	0	160	341	68	188	33	0	289	56	173	83	0	312	601	942

Equivalent 12 & 24-hour Vehicle Volumes Including the Annual Average Daily Traffic (AADT) Factor  
Applicable to the Day and Month of the Turning Movement Count

Expansion factors are applied exclusively to standard weekday 8-hour turning movement counts conducted during the hours of 0700h - 1000h, 1130h - 1330h and 1500h - 1800h

Equivalent 12-hour vehicle volumes. These volumes are calculated by multiplying the 8-hour totals by the 8 → 12 expansion factor of 1.39																								
Eq. 12 Hr	n/a	n/a	n/a	n/a	n/a	n/a	n/a	n/a	n/a	n/a	n/a	n/a	n/a	n/a	n/a	n/a	n/a	n/a	n/a	n/a	n/a	n/a	n/a	n/a
Average daily 12-hour vehicle volumes. These volumes are calculated by multiplying the equivalent 12-hour totals by the AADT factor of 0.7																								
AADT 12-hr	n/a	n/a	n/a	n/a	n/a	n/a	n/a	n/a	n/a	n/a	n/a	n/a	n/a	n/a	n/a	n/a	n/a	n/a	n/a	n/a	n/a	n/a	n/a	n/a
24-Hour AADT. These volumes are calculated by multiplying the average daily 12-hour vehicle volumes by the 12 → 24 expansion factor of 1.31																								
AADT 24 Hr	n/a	n/a	n/a	n/a	n/a	n/a	n/a	n/a	n/a	n/a	n/a	n/a	n/a	n/a	n/a	n/a	n/a	n/a	n/a	n/a	n/a	n/a	n/a	n/a

### AADT and expansion factors provided by the City of Ottawa

AM Peak Hour Factor →		0.86		Highest Hourly Vehicle Volume Between 0700h & 1000h																							
AM Peak Hr	LT	ST	RT	UT	TOT	LT	ST	RT	UT	TOT	S.TOT	LT	ST	RT	UT	TOT	LT	ST	RT	UT	TOT	S.TOT	G.TOT				
0815-0915	11	26	10	0	47	6	8	6	0	20	67	11	49	10	0	70	22	31	16	0	69	139	206				

PM Peak Hour Factor →		0.91		Highest Hourly Vehicle Volume Between 1500h & 1800h																							
PM Peak Hr	LT	ST	RT	UT	TOT	LT	ST	RT	UT	TOT	S.TOT	LT	ST	RT	UT	TOT	LT	ST	RT	UT	TOT	S.TOT	G.TOT				
1630-1730	12	8	10	0	30	4	22	6	0	32	62	24	22	1	0	47	3	45	32	0	80	127	189				

### Comments:

A cedar hedge growing along the property frontage on the southwest quadrant is creating a serious sightline problem. The majority of the cyclists as well as some drivers ignore the all-way stop control. Vehicles parked too close to the intersection on both Laurel Street, east of Breezhill Avenue and Breezhill Avenue, south of Laurel Street create a sightline problem.

### Notes:

1. Includes all vehicle types except bicycles, electric bicycles, and electric scooters.
2. When expansion and AADT factors are applied, the results will differ slightly due to rounding.



## Turning Movement Count Pedestrian Crossings Summary and Flow Diagram



### Breezhill Avenue & Laurel Street Ottawa, ON

#### Pedestrian Crossings

Tuesday, 23 April 2019  
0700-1000 & 1500-1800  
6 Hour Survey  
City of Ottawa Ward ▶ 15

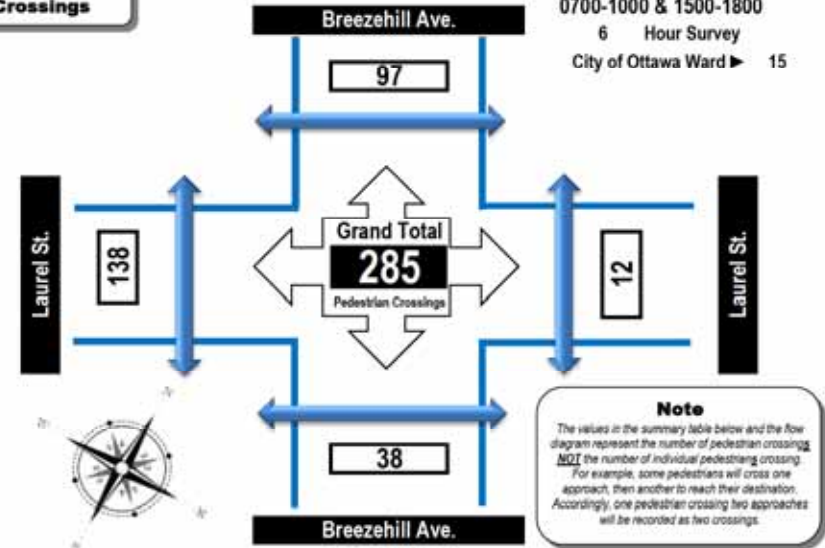

Time Period	West Side Crossing Laurel St.	East Side Crossing Laurel St.	Street Total	South Side Crossing Breezhill Ave.	North Side Crossing Breezhill Ave.	Street Total	Grand Total
0700-0800	5	1	6	3	8	11	17
0800-0900	54	4	58	14	18	32	90
0900-1000	2	0	2	0	4	4	6
1500-1600	50	0	50	12	23	35	85
1600-1700	12	1	13	2	22	24	37
1700-1800	15	6	21	7	22	29	50
Totals	138	12	150	38	97	135	285

### Comments:

A cedar hedge growing along the property frontage on the southwest quadrant is creating a serious sightline problem. The majority of the cyclists as well as some drivers ignore the all-way stop control. Vehicles parked too close to the intersection on both Laurel Street, east of Breezhill Avenue and Breezhill Avenue, south of Laurel Street create a sightline problem.



## Turning Movement Count Bicycle Summary Flow Diagram



**Breezhill Avenue & Laurel Street** Ottawa, ON

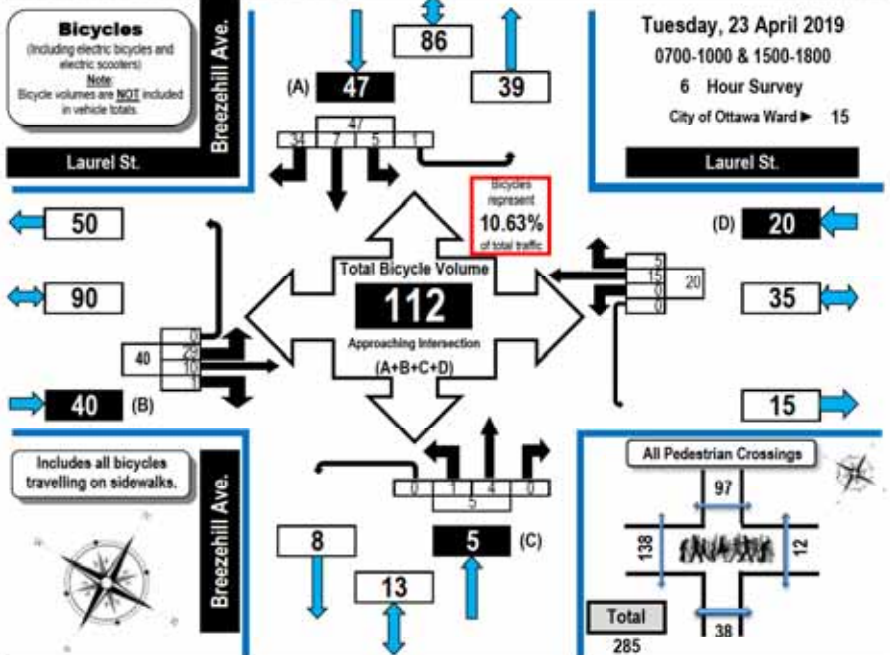

Time Period	Laurel St. Eastbound				Laurel St. Westbound				Breezhill Ave. Northbound				Breezhill Ave. Southbound				S. Tot	O. Tot
	LT	ST	RT	UT	LT	ST	RT	UT	LT	ST	RT	UT	LT	ST	RT	UT		
0700-0800	0	1	0	0	7	0	0	0	0	1	2	0	3	0	0	0	0	10
0800-0900	15	6	1	0	22	2	1	0	3	1	0	0	1	1	0	0	1	28
0900-1000	4	1	0	0	5	0	2	0	2	0	0	0	0	2	0	0	2	9
1500-1600	3	2	0	0	5	3	2	0	5	0	0	0	0	2	1	11	14	24
1600-1700	1	0	0	0	1	4	1	0	5	0	1	0	1	0	2	14	16	23
1700-1800	0	0	0	0	0	4	1	0	5	0	0	0	0	4	9	0	13	18
<b>Totals</b>	<b>29</b>	<b>10</b>	<b>1</b>	<b>0</b>	<b>40</b>	<b>15</b>	<b>5</b>	<b>0</b>	<b>20</b>	<b>1</b>	<b>4</b>	<b>0</b>	<b>5</b>	<b>5</b>	<b>7</b>	<b>34</b>	<b>1</b>	<b>112</b>

**Comments:**  
A cedar hedge growing along the property frontage on the southwest quadrant is creating a serious sightline problem. The majority of the cyclists as well as some drivers ignore the all-way stop control. Vehicles parked too close to the intersection on both Laurel Street, east of Breezhill Avenue and Breezhill Avenue, south of Laurel Street create a sightline problem.



## Turning Movement Count Heavy Vehicle Summary Flow Diagram

Heavy Trucks, Buses,  
and School Buses

**Breezhill Avenue & Laurel Street** Ottawa, ON

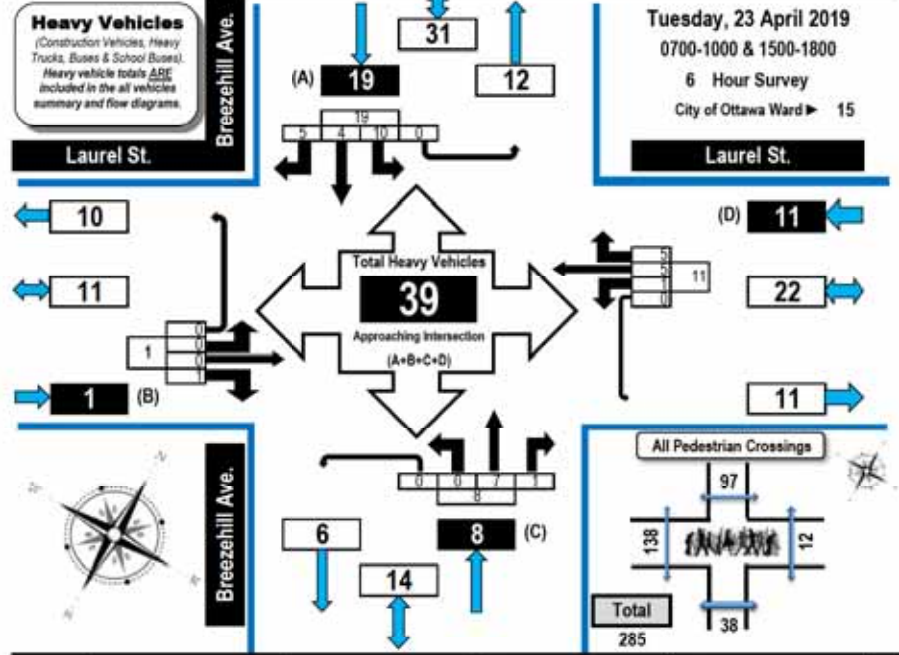

Time Period	Laurel St. Eastbound				Laurel St. Westbound				Breezhill Ave. Northbound				Breezhill Ave. Southbound				S. Tot	O. Tot
	LT	ST	RT	UT	LT	ST	RT	UT	LT	ST	RT	UT	LT	ST	RT	UT		
0700-0800	0	0	0	0	0	0	1	0	1	0	1	0	1	2	0	0	2	4
0800-0900	0	0	0	0	0	0	3	0	3	0	0	1	1	3	0	3	6	10
0900-1000	0	0	1	0	1	1	2	1	4	0	4	0	4	2	2	1	5	14
1500-1600	0	0	0	0	0	1	0	0	1	0	1	0	0	1	1	0	2	4
1600-1700	0	0	0	0	0	1	0	0	1	0	0	0	0	1	1	0	2	3
1700-1800	0	0	0	0	0	0	1	0	1	0	1	0	1	1	1	0	2	4
<b>Totals</b>	<b>0</b>	<b>0</b>	<b>1</b>	<b>0</b>	<b>1</b>	<b>5</b>	<b>5</b>	<b>0</b>	<b>11</b>	<b>0</b>	<b>7</b>	<b>1</b>	<b>8</b>	<b>10</b>	<b>4</b>	<b>5</b>	<b>19</b>	<b>39</b>

**Comments:**  
A cedar hedge growing along the property frontage on the southwest quadrant is creating a serious sightline problem. The majority of the cyclists as well as some drivers ignore the all-way stop control. Vehicles parked too close to the intersection on both Laurel Street, east of Breezhill Avenue and Breezhill Avenue, south of Laurel Street create a sightline problem.



Turning Movement Count - 15 Minute Summary Report

BREEZEHILL AVE @ GLADSTONE AVE

Survey Date: Wednesday, July 18, 2018

Total Observed U-Turns

Northbound: 0 Southbound: 0  
Eastbound: 0 Westbound: 0

Time Period	BREEZEHILL AVE									GLADSTONE AVE									Grand Total
	Northbound			Southbound			Eastbound			Westbound			W			Grand Total			
	LT	ST	RT	N TOT	LT	ST	RT	S TOT	STR TOT	LT	ST	RT	E TOT	LT	ST		RT	W TOT	
07:00 07:15	0	0	0	0	2	0	1	3	3	3	32	0	35	0	18	2	20	55	58
07:15 07:30	0	0	0	0	1	0	3	4	4	4	28	0	32	0	30	8	38	70	74
07:30 07:45	0	1	1	2	0	0	3	3	5	3	36	0	39	0	18	4	22	61	66
07:45 08:00	0	0	1	1	5	1	3	9	10	7	36	0	43	0	35	2	37	80	90
08:00 08:15	0	0	1	1	4	0	4	8	9	4	40	0	44	0	30	4	34	78	87
08:15 08:30	0	0	1	1	1	0	7	8	9	10	40	0	50	0	40	8	48	107	116
08:30 08:45	1	1	0	2	3	0	8	11	13	4	53	0	57	0	42	7	49	106	119
08:45 09:00	0	0	1	1	2	0	1	3	4	5	60	0	65	1	44	8	53	118	122
09:00 09:15	1	0	1	2	2	0	2	4	6	4	38	0	42	0	27	14	41	83	89
09:15 09:30	0	0	0	0	6	0	6	12	12	8	42	0	50	0	46	9	55	105	117
09:30 09:45	0	0	0	0	9	0	7	16	16	3	35	0	38	2	38	8	48	86	102
09:45 10:00	2	1	0	3	5	0	5	10	13	9	42	0	51	0	32	1	33	84	97
11:30 11:45	2	0	1	3	5	0	5	10	13	3	44	0	47	1	39	4	44	91	104
11:45 12:00	1	0	0	1	7	0	4	11	12	9	43	1	53	1	39	2	42	95	107
12:00 12:15	1	0	0	1	7	0	7	14	15	7	40	1	48	0	42	6	48	96	111
12:15 12:30	1	0	1	2	5	0	5	10	12	1	30	3	43	0	48	8	56	99	111
12:30 12:45	0	1	0	1	8	0	3	11	12	5	38	0	41	0	37	4	41	82	94
12:45 13:00	0	1	3	4	5	1	5	11	15	5	37	0	42	1	31	1	33	75	90
13:00 13:15	0	0	0	0	2	0	4	6	6	2	45	0	47	0	49	2	51	98	104
13:15 13:30	1	0	0	1	2	1	3	6	7	1	39	1	41	1	58	2	61	102	109
15:00 15:15	2	1	0	3	2	0	6	8	11	2	43	1	46	0	67	5	72	118	129
15:15 15:30	1	1	1	3	4	0	3	7	10	0	37	0	37	0	87	4	91	128	138
15:30 15:45	1	1	0	2	7	0	4	11	13	2	39	0	41	0	88	2	90	131	144
15:45 16:00	0	0	2	2	5	0	7	12	14	4	45	0	49	0	105	5	110	159	173
16:00 16:15	0	0	0	0	2	0	6	8	8	4	56	1	61	0	103	5	108	169	177
16:15 16:30	1	0	1	2	10	0	10	20	22	2	56	2	60	2	124	5	131	191	213
16:30 16:45	0	0	0	0	6	0	2	8	8	8	46	2	56	0	118	9	127	183	191
16:45 17:00	0	0	0	0	7	0	6	13	13	3	41	0	44	1	133	5	139	183	196
17:00 17:15	2	0	0	2	5	0	5	10	12	4	44	0	48	3	122	8	133	181	193
17:15 17:30	1	0	2	3	4	1	2	7	10	0	49	1	50	2	112	3	117	167	177
17:30 17:45	2	0	1	3	1	0	6	7	10	2	34	2	38	1	114	2	117	155	165
17:45 18:00	0	0	0	0	6	0	1	7	7	0	30	0	30	0	93	1	94	124	131
<b>TOTAL:</b>	<b>20</b>	<b>8</b>	<b>18</b>	<b>46</b>	<b>140</b>	<b>4</b>	<b>144</b>	<b>288</b>	<b>334</b>	<b>128</b>	<b>1334</b>	<b>15</b>	<b>1477</b>	<b>18</b>	<b>2009</b>	<b>158</b>	<b>2183</b>	<b>3660</b>	<b>3994</b>

Note: U-Turns are included in Totals.

Comment:



BREEZEHILL AVE @ GLADSTONE AVE

Count Date: Wednesday, July 18, 2018

Start Time: 07:00

Time Period	BREEZEHILL AVE			GLADSTONE AVE			Grand Total
	Northbound	Southbound	Street Total	Eastbound	Westbound	Street Total	
07:00 08:00	4	1	5	39	23	62	67
08:00 09:00	2	2	4	98	15	113	117
09:00 10:00	0	1	1	29	24	53	54
11:30 12:30	0	0	0	17	11	28	28
12:30 13:30	0	2	2	7	10	17	19
15:00 16:00	1	3	4	26	33	59	63
16:00 17:00	1	3	4	28	49	77	81
17:00 18:00	2	6	8	36	71	107	115
<b>Total</b>	<b>10</b>	<b>18</b>	<b>28</b>	<b>280</b>	<b>236</b>	<b>516</b>	<b>544</b>

Comment:

Note: These volumes consists of bicycles only (no mopeds or motorcycles) and ARE NOT included in the Turning Movement Count Summary.



Transportation Services - Traffic Services  
Turning Movement Count - Full Study Diagram

BREEZEHILL AVE @ GLADSTONE AVE

Survey Date: Wednesday, July 18, 2018

WO#: 37971  
Device: Miovision

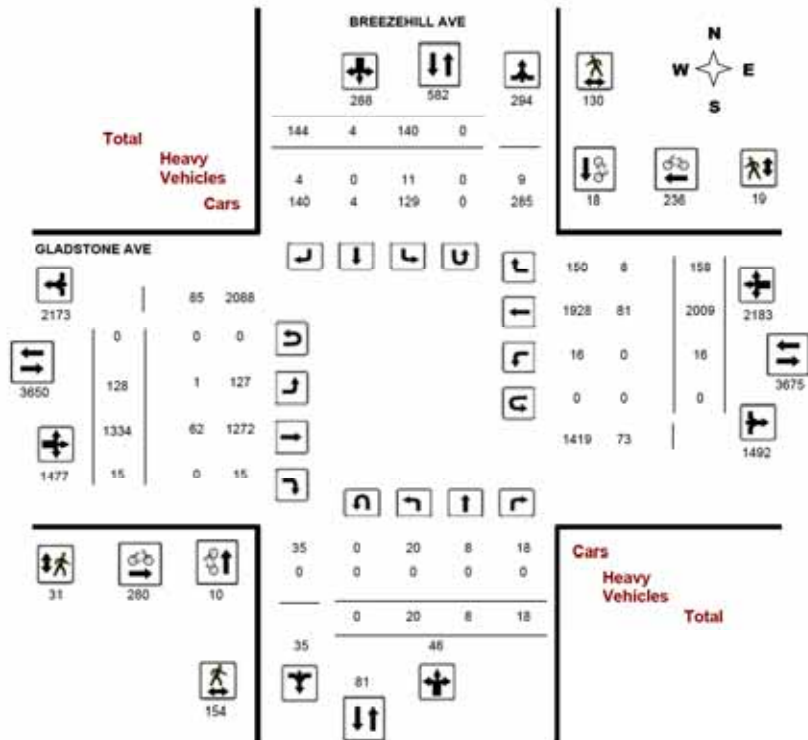

Comments



Transportation Services - Traffic Services

W.O.  
37971

Turning Movement Count - Heavy Vehicle Report

BREEZEHILL AVE @ GLADSTONE AVE

Survey Date: Wednesday, July 18, 2018

Time Period	BREEZEHILL AVE								GLADSTONE AVE								W TOT	STR TOT	Grand Total	
	Northbound				Southbound				Eastbound				Westbound							
	LT	ST	RT	N TOT	LT	ST	RT	S TOT	STR TOT	LT	ST	RT	E TOT	LT	ST	RT				
07:00	0	0	0	0	0	0	0	1	1	1	0	11	0	11	0	12	1	13	24	25
08:00	0	0	0	0	0	0	0	0	0	0	0	11	0	11	0	11	0	11	22	22
09:00	0	0	0	0	1	0	0	1	1	0	10	0	10	0	12	1	13	23	24	24
11:30	0	0	0	0	4	0	2	6	6	1	9	0	10	0	10	3	13	23	29	29
12:30	0	0	0	0	1	0	1	2	2	0	7	0	7	0	9	0	9	16	18	18
15:00	0	0	0	0	1	0	0	1	1	0	5	0	5	0	6	0	6	11	12	12
16:00	0	0	0	0	3	0	0	3	3	0	7	0	7	0	15	3	18	25	28	28
17:00	0	0	0	0	1	0	0	1	1	0	2	0	2	0	6	0	6	8	9	9
<b>Sub Total</b>	<b>0</b>	<b>0</b>	<b>0</b>	<b>0</b>	<b>11</b>	<b>0</b>	<b>4</b>	<b>15</b>	<b>15</b>	<b>1</b>	<b>62</b>	<b>0</b>	<b>63</b>	<b>0</b>	<b>81</b>	<b>8</b>	<b>89</b>	<b>152</b>	<b>167</b>	<b>167</b>
<b>U-Turns (Heavy Vehicles)</b>	<b>0</b>	<b>0</b>	<b>0</b>	<b>0</b>	<b>0</b>	<b>0</b>	<b>0</b>	<b>0</b>	<b>0</b>	<b>0</b>	<b>0</b>	<b>0</b>	<b>0</b>	<b>0</b>	<b>0</b>	<b>0</b>	<b>0</b>	<b>0</b>	<b>0</b>	<b>0</b>
<b>Total</b>	<b>0</b>	<b>0</b>	<b>0</b>	<b>0</b>	<b>11</b>	<b>0</b>	<b>4</b>	<b>15</b>	<b>15</b>	<b>1</b>	<b>62</b>	<b>0</b>	<b>63</b>	<b>0</b>	<b>81</b>	<b>8</b>	<b>89</b>	<b>152</b>	<b>167</b>	<b>167</b>

Heavy Vehicles include Buses, Single-Unit Trucks and Articulated Trucks. Further, they ARE included in the Turning Movement Count Summary.



# Transportation Services - Traffic Services

Work Order  
37971

## Turning Movement Count - Pedestrian Volume Report

### BREEZEHILL AVE @ GLADSTONE AVE

Count Date: Wednesday, July 18, 2018

Start Time: 07:00

Time Period	NB Approach (E or W Crossing)	SB Approach (E or W Crossing)	Total	EB Approach (N or S Crossing)	WB Approach (N or S Crossing)	Total	Grand Total
07:00 07:15	8	5	11	1	0	1	12
07:15 07:30	5	3	8	1	1	2	10
07:30 07:45	7	3	10	0	2	2	12
07:45 08:00	2	3	5	0	2	2	7
07:00 08:00	20	14	34	2	5	7	41
08:00 08:15	5	4	9	0	0	0	9
08:15 08:30	8	2	10	3	0	3	13
08:30 08:45	11	6	17	2	1	3	20
08:45 09:00	5	9	14	4	0	4	18
08:00 09:00	29	21	50	9	1	10	60
09:00 09:15	6	3	9	2	1	3	12
09:15 09:30	3	3	6	0	0	0	6
09:30 09:45	1	2	3	2	0	2	5
09:45 10:00	6	3	9	0	0	0	9
09:00 10:00	18	11	27	4	1	5	32
11:30 11:45	7	7	14	0	0	0	14
11:45 12:00	5	1	6	1	0	1	7
12:00 12:15	3	4	7	1	0	1	8
12:15 12:30	6	2	8	0	0	0	8
11:30 12:30	23	14	35	2	0	2	37
12:30 12:45	2	5	7	2	0	2	9
12:45 13:00	2	2	4	1	0	1	5
13:00 13:15	4	3	7	0	0	0	7
13:15 13:30	2	3	5	0	0	0	5
12:30 13:30	10	13	23	3	0	3	26
15:00 15:15	9	3	12	0	0	0	12
15:15 15:30	3	1	4	1	0	1	5
15:30 15:45	6	3	9	0	0	0	9
15:45 16:00	4	7	11	0	0	0	11
15:00 16:00	22	14	36	1	0	1	37
16:00 16:15	2	7	9	0	0	0	9
16:15 16:30	3	7	10	1	5	6	16
16:30 16:45	5	6	11	4	3	7	18
16:45 17:00	7	3	10	0	1	1	11
16:00 17:00	17	23	40	5	9	14	54
17:00 17:15	10	6	16	2	1	3	19
17:15 17:30	5	7	12	0	1	1	13
17:30 17:45	0	2	2	0	1	1	3
17:45 18:00	4	5	9	3	0	3	12
17:00 18:00	19	20	39	5	3	8	47
Total	154	130	284	31	19	50	334

Comment:



# Transportation Services - Traffic Services

Work Order  
37971

## Turning Movement Count - Full Study Summary Report

### BREEZEHILL AVE @ GLADSTONE AVE

Survey Date: Wednesday, July 18, 2018

Total Observed U-Turns

AADT Factor

Northbound: 0	Southbound: 0	.90
Eastbound: 0	Westbound: 0	

### Full Study

Period	BREEZEHILL AVE				GLADSTONE AVE				WB TOT	STR TOT	Grand Total								
	Northbound		Southbound		Eastbound		Westbound												
	LT	ST	RT	NB TOT	LT	ST	RT	SB TOT				STR TOT	LT	ST	RT	WB TOT	STR TOT		
07:00 08:00	0	1	2	3	8	1	10	19	22	17	132	0	149	0	101	16	117	266	283
08:00 09:00	1	1	3	5	10	0	20	30	35	23	202	0	225	1	156	27	184	489	444
09:00 10:00	3	1	1	5	22	0	20	42	47	24	137	0	181	2	143	32	177	358	405
11:30 12:30	5	0	2	7	24	0	21	45	52	20	166	5	191	2	168	20	190	381	433
12:30 13:30	1	2	3	6	17	2	15	34	40	13	157	1	171	2	175	9	186	357	397
15:00 16:00	4	3	3	10	18	0	20	38	48	8	164	1	173	0	347	16	363	536	584
16:00 17:00	1	0	1	2	25	0	24	49	51	17	199	5	221	3	478	24	505	726	777
17:00 18:00	5	0	3	8	16	1	14	31	39	0	157	3	166	6	441	14	461	627	666
Sub Total	20	8	18	46	140	4	144	288	334	128	1334	15	1477	16	2009	158	2183	3668	3994
U Turns				0				0	0				0				0	0	0
Total	20	8	18	46	140	4	144	288	334	128	1334	15	1477	16	2009	158	2183	3668	3994
EQ 12hr	28	11	25	64	195	6	200	400	464	178	1854	21	2053	22	2793	220	3034	5087	5551
Note: These values are calculated by multiplying the totals by the appropriate expansion factor.													1.39						
AVG 12hr	25	10	23	58	175	5	180	360	418	160	1699	19	1848	20	2513	198	2731	4579	4997
Note: These volumes are calculated by multiplying the Equivalent 12 hr. totals by the AADT factor.													.90						
AVG 24hr	33	13	29	75	229	7	236	472	547	210	2186	25	2421	26	3292	259	3578	5999	6546
Note: These volumes are calculated by multiplying the Average Daily 12 hr. totals by 12 to 24 expansion factor.													1.31						

### Comments:

Note: U-Turns provided for approach totals. Refer to 'U-Turn' Report for specific breakdown.



### Transportation Services - Traffic Services

#### Turning Movement Count - Peak Hour Diagram

#### BREEZEHILL AVE @ GLADSTONE AVE

Survey Date: Wednesday, July 18, 2018

Start Time: 07:00

WO No: 37971

Device: Miovision

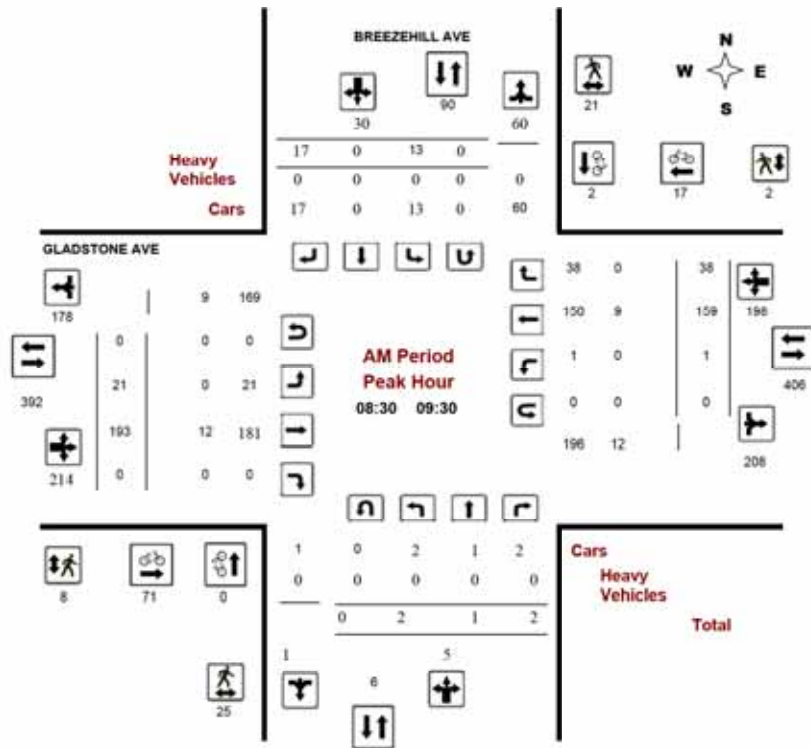

Comments



### Transportation Services - Traffic Services

#### Turning Movement Count - Peak Hour Diagram

#### BREEZEHILL AVE @ GLADSTONE AVE

Survey Date: Wednesday, July 18, 2018

Start Time: 07:00

WO No: 37971

Device: Miovision

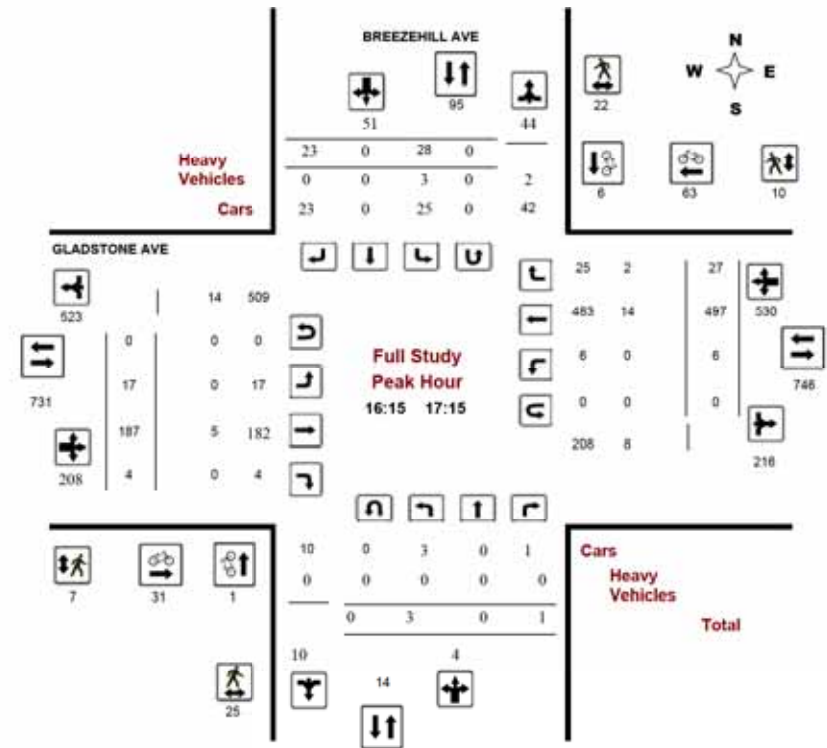

Comments



# Transportation Services - Traffic Services

## Turning Movement Count - Peak Hour Diagram

### BREEZEHILL AVE @ GLADSTONE AVE

Survey Date: Wednesday, July 18, 2018

Start Time: 07:00

WO No: 37971

Device: Miovision

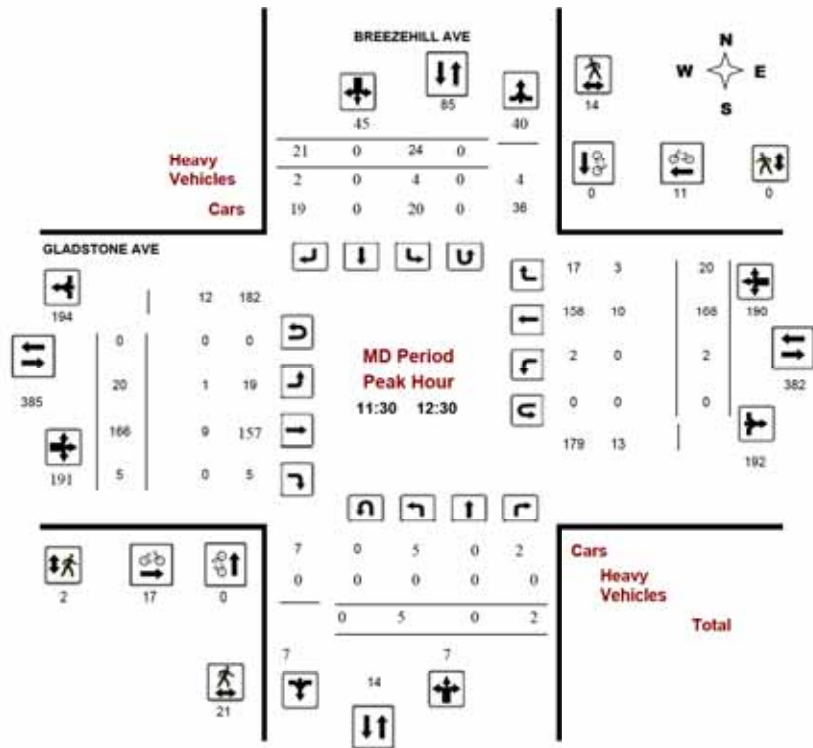

Comments



# Transportation Services - Traffic Services

## Turning Movement Count - Peak Hour Diagram

### BREEZEHILL AVE @ GLADSTONE AVE

Survey Date: Wednesday, July 18, 2018

Start Time: 07:00

WO No: 37971

Device: Miovision

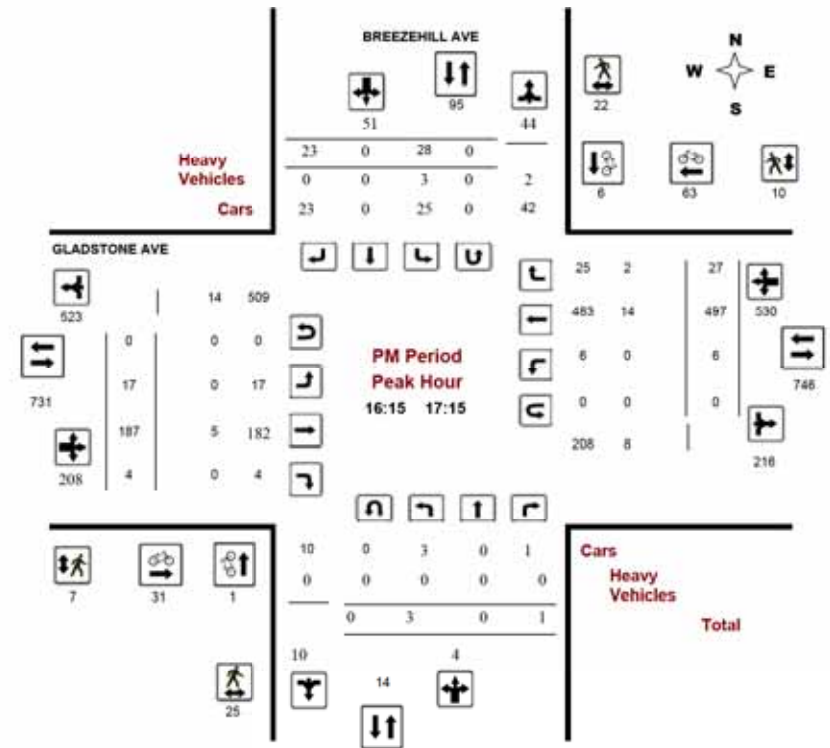

Comments



### Transportation Services - Traffic Services

Work Order  
37971

#### Turning Movement Count - 15 Min U-Turn Total Report

#### BREEZEHILL AVE @ GLADSTONE AVE

Survey Date: Wednesday, July 18, 2018

Time Period	Northbound U-Turn Total	Southbound U-Turn Total	Eastbound U-Turn Total	Westbound U-Turn Total	Total
07:00 07:15	0	0	0	0	0
07:15 07:30	0	0	0	0	0
07:30 07:45	0	0	0	0	0
07:45 08:00	0	0	0	0	0
08:00 08:15	0	0	0	0	0
08:15 08:30	0	0	0	0	0
08:30 08:45	0	0	0	0	0
08:45 09:00	0	0	0	0	0
09:00 09:15	0	0	0	0	0
09:15 09:30	0	0	0	0	0
09:30 09:45	0	0	0	0	0
09:45 10:00	0	0	0	0	0
11:30 11:45	0	0	0	0	0
11:45 12:00	0	0	0	0	0
12:00 12:15	0	0	0	0	0
12:15 12:30	0	0	0	0	0
12:30 12:45	0	0	0	0	0
12:45 13:00	0	0	0	0	0
13:00 13:15	0	0	0	0	0
13:15 13:30	0	0	0	0	0
15:00 15:15	0	0	0	0	0
15:15 15:30	0	0	0	0	0
15:30 15:45	0	0	0	0	0
15:45 16:00	0	0	0	0	0
16:00 16:15	0	0	0	0	0
16:15 16:30	0	0	0	0	0
16:30 16:45	0	0	0	0	0
16:45 17:00	0	0	0	0	0
17:00 17:15	0	0	0	0	0
17:15 17:30	0	0	0	0	0
17:30 17:45	0	0	0	0	0
17:45 18:00	0	0	0	0	0
<b>Total</b>	<b>0</b>	<b>0</b>	<b>0</b>	<b>0</b>	<b>0</b>



### Transportation Services - Traffic Services

W.O. 35301

#### Turning Movement Count - 15 Minute Summary Report

#### BREEZEHILL AVE @ SOMERSET ST

Survey Date: Thursday, August 13, 2015

Total Observed U-Turns

Northbound: 0 Southbound: 0  
Eastbound: 4 Westbound: 2

		BREEZEHILL AVE				SOMERSET ST													
		Northbound		Southbound		Eastbound		Westbound											
Time Period	LT	ST	RT	N TOT	LT	ST	RT	S TOT	STR TOT	LT	ST	RT	E TOT	LT	ST	RT	W TOT	STR TOT	Grand Total
07:00 07:15	2	0	2	4	0	0	0	0	4	0	27	5	32	3	21	0	24	56	60
07:15 07:30	0	0	6	6	0	0	0	0	6	0	29	3	32	2	35	0	37	69	75
07:30 07:45	2	0	3	5	0	0	0	0	5	0	53	2	55	1	35	0	36	91	96
07:45 08:00	2	0	4	6	0	0	0	0	6	0	62	3	65	4	54	0	58	123	129
08:00 08:15	3	0	6	9	0	0	0	0	9	0	65	5	70	4	56	0	60	130	139
08:15 08:30	4	0	5	9	0	0	0	0	9	0	92	3	95	4	42	0	46	141	150
08:30 08:45	3	0	4	7	0	0	0	0	7	0	54	5	59	3	40	0	43	102	109
08:45 09:00	3	0	9	12	0	0	0	0	12	0	64	4	68	4	50	0	54	122	134
09:00 09:15	3	0	6	9	0	0	0	0	9	0	63	8	71	5	68	0	73	144	153
09:15 09:30	5	0	4	9	0	0	0	0	9	0	62	4	66	5	53	0	58	124	133
09:30 09:45	6	0	7	13	0	0	0	0	13	0	76	3	79	2	66	0	68	147	160
09:45 10:00	2	0	5	7	0	0	0	0	7	0	59	10	70	2	67	0	69	139	146
11:30 11:45	5	0	2	7	0	0	0	0	7	0	81	2	83	3	74	0	77	160	167
11:45 12:00	9	0	3	12	0	0	0	0	12	0	81	3	84	5	69	0	74	158	170
12:00 12:15	7	0	12	19	0	0	0	0	19	0	78	8	86	12	80	0	92	178	197
12:15 12:30	4	0	8	12	0	0	0	0	12	0	69	4	74	5	70	0	75	149	161
12:30 12:45	6	0	3	9	0	0	0	0	9	0	71	5	76	2	64	0	66	142	151
12:45 13:00	1	0	4	5	0	0	0	0	5	0	80	9	89	5	72	0	77	166	171
13:00 13:15	4	0	3	7	0	0	0	0	7	0	65	7	72	2	66	0	68	140	147
13:15 13:30	5	0	5	10	0	0	0	0	10	0	49	5	54	6	86	0	92	146	156
15:00 15:15	6	0	2	8	0	0	0	0	8	0	65	5	70	2	74	0	76	146	154
15:15 15:30	7	0	6	13	0	0	0	0	13	0	66	2	68	5	69	0	94	162	175
15:30 15:45	8	0	8	16	0	0	0	0	16	0	58	4	62	3	93	0	96	158	174
15:45 16:00	4	0	2	6	0	0	0	0	6	0	61	4	66	6	75	0	81	147	153
16:00 16:15	2	0	7	9	0	0	0	0	9	0	73	3	76	5	96	0	101	177	186
16:15 16:30	3	0	5	8	0	0	0	0	8	0	87	7	94	7	108	0	115	209	217
16:30 16:45	5	0	3	8	0	0	0	0	8	0	65	8	73	4	104	0	109	182	190
16:45 17:00	3	0	4	7	0	0	0	0	7	0	86	3	89	6	114	0	120	209	216
17:00 17:15	8	0	3	11	0	0	0	0	11	0	78	5	83	2	92	0	94	177	188
17:15 17:30	4	0	3	7	0	0	0	0	7	0	78	3	81	7	113	0	121	202	209
17:30 17:45	4	0	5	9	0	0	0	0	9	0	64	3	68	7	110	0	117	185	194
17:45 18:00	2	0	6	8	0	0	0	0	8	0	76	2	78	3	93	0	96	174	182
<b>TOTAL:</b>	<b>132</b>	<b>0</b>	<b>155</b>	<b>287</b>	<b>0</b>	<b>0</b>	<b>0</b>	<b>0</b>	<b>287</b>	<b>0</b>	<b>2137</b>	<b>147</b>	<b>2288</b>	<b>136</b>	<b>2329</b>	<b>0</b>	<b>2467</b>	<b>4755</b>	<b>5042</b>

Note: U-Turns are included in Totals.

Comment:



**Transportation Services - Traffic Services**  
**Turning Movement Count - Cyclist Volume Report**

Work Order  
 35301

**BREEZEHILL AVE @ SOMERSET ST**

Count Date: Thursday, August 13, 2015

Start Time: 07:00

Time Period	BREEZEHILL AVE			SOMERSET ST			Grand Total
	Northbound	Southbound	Street Total	Eastbound	Westbound	Street Total	
07:00 08:00	6	0	6	38	24	62	68
08:00 09:00	17	0	17	99	39	138	155
09:00 10:00	6	0	6	33	28	61	67
11:30 12:30	4	0	4	28	25	53	57
12:30 13:30	2	0	2	21	30	51	53
15:00 16:00	3	0	3	41	34	75	78
16:00 17:00	3	0	3	50	79	129	132
17:00 18:00	4	0	4	59	101	160	164
<b>Total</b>	<b>45</b>	<b>0</b>	<b>45</b>	<b>369</b>	<b>360</b>	<b>729</b>	<b>774</b>

Comment:

Note: These volumes consists of bicycles only (no mopeds or motorcycles) and ARE NOT included in the Turning Movement Count Summary.



**Transportation Services - Traffic Services**  
**Turning Movement Count - Full Study Diagram**

**BREEZEHILL AVE @ SOMERSET ST**

Survey Date: Thursday, August 13, 2015

WO#: 35301  
 Device: Miovision

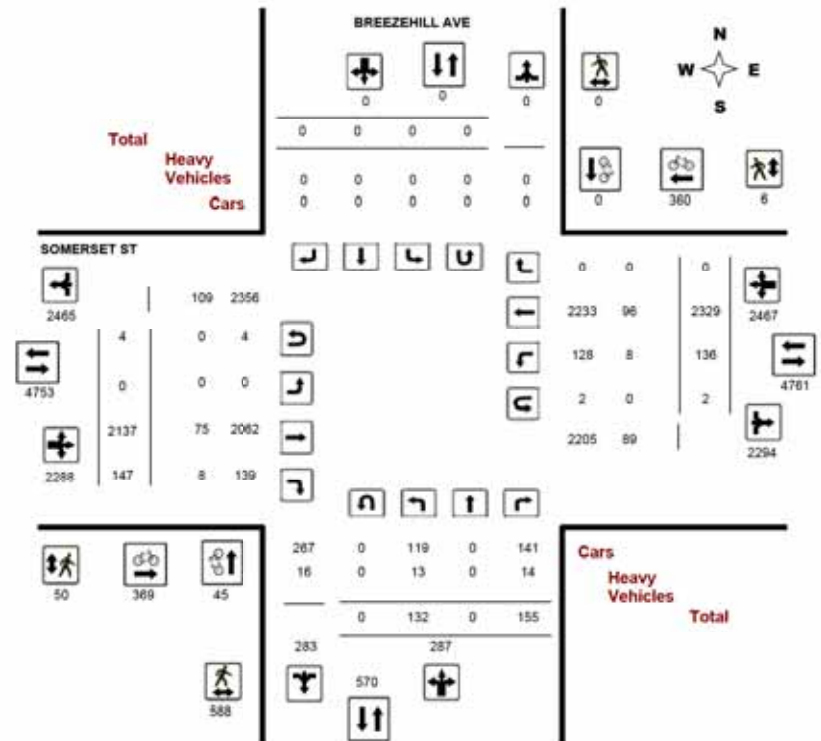

Comments



# Transportation Services - Traffic Services

W.O.  
35301

## Turning Movement Count - Heavy Vehicle Report

### BREEZEHILL AVE @ SOMERSET ST

Survey Date: Thursday, August 13, 2015

BREEZEHILL AVE										SOMERSET ST										Grand Total
Time Period	Northbound			Southbound			S TOT	STR TOT	Eastbound			Westbound			W TOT	STR TOT				
	LT	ST	RT	LT	ST	RT			LT	ST	RT	LT	ST	RT						
07:00 08:00	2	0	1	3	0	0	0	3	0	7	1	8	2	12	0	14	22	25		
08:00 09:00	1	0	2	3	0	0	0	3	0	12	0	12	1	15	0	16	28	31		
09:00 10:00	4	0	6	10	0	0	0	10	0	11	2	13	0	15	0	15	28	38		
11:30 12:30	4	0	2	6	0	0	0	6	0	10	0	10	4	11	0	15	25	31		
12:30 13:30	1	0	0	1	0	0	0	1	0	7	3	10	1	13	0	14	24	25		
15:00 16:00	1	0	3	4	0	0	0	4	0	11	0	11	0	15	0	15	26	30		
16:00 17:00	0	0	0	0	0	0	0	0	0	7	1	8	0	7	0	7	15	15		
17:00 18:00	0	0	0	0	0	0	0	0	0	10	1	11	0	8	0	8	19	19		
<b>Sub Total</b>	<b>13</b>	<b>0</b>	<b>14</b>	<b>27</b>	<b>0</b>	<b>0</b>	<b>0</b>	<b>27</b>	<b>0</b>	<b>75</b>	<b>8</b>	<b>83</b>	<b>8</b>	<b>96</b>	<b>0</b>	<b>104</b>	<b>187</b>	<b>214</b>		
<b>U-Turns (Heavy Vehicles)</b>	<b>0</b>	<b>0</b>	<b>0</b>	<b>0</b>	<b>0</b>	<b>0</b>	<b>0</b>	<b>0</b>	<b>0</b>	<b>0</b>	<b>0</b>	<b>0</b>	<b>0</b>	<b>0</b>	<b>0</b>	<b>0</b>	<b>0</b>	<b>0</b>		
<b>Total</b>	<b>13</b>	<b>0</b>	<b>14</b>	<b>27</b>	<b>0</b>	<b>0</b>	<b>0</b>	<b>27</b>	<b>0</b>	<b>75</b>	<b>8</b>	<b>83</b>	<b>8</b>	<b>96</b>	<b>0</b>	<b>104</b>	<b>187</b>	<b>214</b>		

Heavy Vehicles include Buses, Single-Unit Trucks and Articulated Trucks. Further, they ARE included in the Turning Movement Count Summary.



# Transportation Services - Traffic Services

Work Order  
35301

## Turning Movement Count - Pedestrian Volume Report

### BREEZEHILL AVE @ SOMERSET ST

Count Date: Thursday, August 13, 2015

Start Time: 07:00

Time Period	NB Approach (E or W Crossing)	SB Approach (E or W Crossing)	Total	EB Approach (N or S Crossing)	WB Approach (N or S Crossing)	Total	Grand Total
07:00 07:15	8	0	8	0	0	0	8
07:15 07:30	8	0	8	0	1	1	9
07:30 07:45	14	0	14	1	0	1	15
07:45 08:00	15	0	15	2	1	3	18
<b>07:00 08:00</b>	<b>45</b>	<b>0</b>	<b>45</b>	<b>3</b>	<b>2</b>	<b>5</b>	<b>50</b>
08:00 08:15	10	0	10	1	1	2	12
08:15 08:30	25	0	25	0	0	0	25
08:30 08:45	14	0	14	3	0	3	17
08:45 09:00	10	0	10	0	0	0	10
<b>08:00 09:00</b>	<b>59</b>	<b>0</b>	<b>59</b>	<b>4</b>	<b>1</b>	<b>5</b>	<b>64</b>
09:00 09:15	13	0	13	0	0	0	13
09:15 09:30	12	0	12	0	0	0	12
09:30 09:45	16	0	16	0	0	0	16
09:45 10:00	9	0	9	0	0	0	9
<b>09:00 10:00</b>	<b>50</b>	<b>0</b>	<b>50</b>	<b>0</b>	<b>0</b>	<b>0</b>	<b>50</b>
11:30 11:45	18	0	18	2	0	2	20
11:45 12:00	8	0	8	3	0	3	11
12:00 12:15	21	0	21	2	0	2	23
12:15 12:30	19	0	19	0	1	1	20
<b>11:30 12:30</b>	<b>66</b>	<b>0</b>	<b>66</b>	<b>7</b>	<b>1</b>	<b>8</b>	<b>74</b>
12:30 12:45	21	0	21	0	0	0	21
12:45 13:00	16	0	16	0	0	0	16
13:00 13:15	16	0	16	0	0	0	16
13:15 13:30	18	0	18	0	1	1	19
<b>12:30 13:30</b>	<b>71</b>	<b>0</b>	<b>71</b>	<b>0</b>	<b>1</b>	<b>1</b>	<b>72</b>
15:00 15:15	19	0	19	2	0	2	21
15:15 15:30	26	0	26	1	0	1	27
15:30 15:45	21	0	21	1	0	1	22
15:45 16:00	21	0	21	0	0	0	21
15:00 16:00	87	0	87	4	0	4	91
16:00 16:15	13	0	13	2	0	2	15
16:15 16:30	20	0	20	6	0	6	26
16:30 16:45	24	0	24	3	0	3	27
16:45 17:00	30	0	30	6	0	6	36
16:00 17:00	87	0	87	17	0	17	104
17:00 17:15	26	0	26	3	0	3	29
17:15 17:30	37	0	37	5	1	6	43
17:30 17:45	35	0	35	7	0	7	42
17:45 18:00	25	0	25	0	0	0	25
<b>17:00 18:00</b>	<b>123</b>	<b>0</b>	<b>123</b>	<b>15</b>	<b>1</b>	<b>16</b>	<b>139</b>
<b>Total</b>	<b>589</b>	<b>0</b>	<b>588</b>	<b>50</b>	<b>6</b>	<b>56</b>	<b>644</b>

Comment:



# Transportation Services - Traffic Services

Work Order  
35301

## Turning Movement Count - Full Study Summary Report

### BREEZEHILL AVE @ SOMERSET ST

Survey Date: Thursday, August 13, 2015

<b>Total Observed U-Turns</b>		<b>AADT Factor</b>
Northbound: 0	Southbound: 0	.90
Eastbound: 4	Westbound: 2	

#### Full Study

Period	BREEZEHILL AVE										SOMERSET ST										Grand Total
	Northbound					Southbound					Eastbound					Westbound					
	LT	ST	RT	NB TOT	STR TOT	LT	ST	RT	SB TOT	STR TOT	LT	ST	RT	EB TOT	STR TOT	LT	ST	RT	WB TOT	STR TOT	
07:00-08:00	6	0	15	21	0	0	0	0	0	21	0	171	13	184	10	145	0	155	339	360	
08:00-09:00	13	0	24	37	0	0	0	0	0	37	0	275	17	292	15	188	0	203	495	532	
09:00-10:00	18	0	22	38	0	0	0	0	0	38	0	200	25	285	14	254	0	268	553	591	
11:30-12:30	25	0	25	50	0	0	0	0	0	50	0	300	17	326	25	293	0	318	644	684	
12:30-13:30	16	0	15	31	0	0	0	0	0	31	0	265	26	291	15	288	0	303	594	625	
15:00-16:00	25	0	18	43	0	0	0	0	0	43	0	250	15	265	18	331	0	347	612	655	
16:00-17:00	13	0	19	32	0	0	0	0	0	32	0	311	21	332	22	422	0	444	776	808	
17:00-18:00	18	0	17	35	0	0	0	0	0	35	0	296	13	309	19	408	0	427	736	771	
<b>Sub Total</b>	<b>132</b>	<b>0</b>	<b>155</b>	<b>287</b>	<b>0</b>	<b>0</b>	<b>0</b>	<b>0</b>	<b>0</b>	<b>287</b>	<b>0</b>	<b>2137</b>	<b>147</b>	<b>2284</b>	<b>138</b>	<b>2329</b>	<b>0</b>	<b>2465</b>	<b>4749</b>	<b>5036</b>	
<b>U Turns</b>	<b>0</b>	<b>0</b>	<b>0</b>	<b>0</b>	<b>0</b>	<b>0</b>	<b>0</b>	<b>0</b>	<b>0</b>	<b>0</b>	<b>0</b>	<b>4</b>	<b>0</b>	<b>4</b>	<b>0</b>	<b>0</b>	<b>0</b>	<b>2</b>	<b>6</b>	<b>6</b>	
<b>Total</b>	<b>132</b>	<b>0</b>	<b>155</b>	<b>287</b>	<b>0</b>	<b>0</b>	<b>0</b>	<b>0</b>	<b>0</b>	<b>287</b>	<b>0</b>	<b>2137</b>	<b>147</b>	<b>2288</b>	<b>138</b>	<b>2329</b>	<b>0</b>	<b>2467</b>	<b>4755</b>	<b>5042</b>	
<b>EQ 12Hr</b>	<b>183</b>	<b>0</b>	<b>215</b>	<b>399</b>	<b>0</b>	<b>0</b>	<b>0</b>	<b>0</b>	<b>0</b>	<b>399</b>	<b>0</b>	<b>2970</b>	<b>204</b>	<b>3180</b>	<b>189</b>	<b>3237</b>	<b>0</b>	<b>3429</b>	<b>6609</b>	<b>7066</b>	
Note: These values are calculated by multiplying the totals by the appropriate expansion factor.											<b>1.39</b>										
<b>AVG 12Hr</b>	<b>185</b>	<b>0</b>	<b>194</b>	<b>359</b>	<b>0</b>	<b>0</b>	<b>0</b>	<b>0</b>	<b>0</b>	<b>359</b>	<b>0</b>	<b>2673</b>	<b>184</b>	<b>2862</b>	<b>170</b>	<b>2914</b>	<b>0</b>	<b>3086</b>	<b>5948</b>	<b>6367</b>	
Note: These volumes are calculated by multiplying the Equivalent 12 hr. totals by the AADT factor.											<b>.90</b>										
<b>AVG 24Hr</b>	<b>216</b>	<b>0</b>	<b>254</b>	<b>470</b>	<b>0</b>	<b>0</b>	<b>0</b>	<b>0</b>	<b>0</b>	<b>470</b>	<b>0</b>	<b>3502</b>	<b>241</b>	<b>3750</b>	<b>223</b>	<b>3817</b>	<b>0</b>	<b>4043</b>	<b>7793</b>	<b>8263</b>	
Note: These volumes are calculated by multiplying the Average Daily 12 hr. totals by 12 to 24 expansion factor.											<b>1.31</b>										

#### Comments:

Note: U-Turns provided for approach totals. Refer to 'U-Turn' Report for specific breakdown.



# Transportation Services - Traffic Services

## Turning Movement Count - Peak Hour Diagram

### BREEZEHILL AVE @ SOMERSET ST

Survey Date: Thursday, August 13, 2015

Start Time: 07:00

WO No: 35301

Device: Miovision

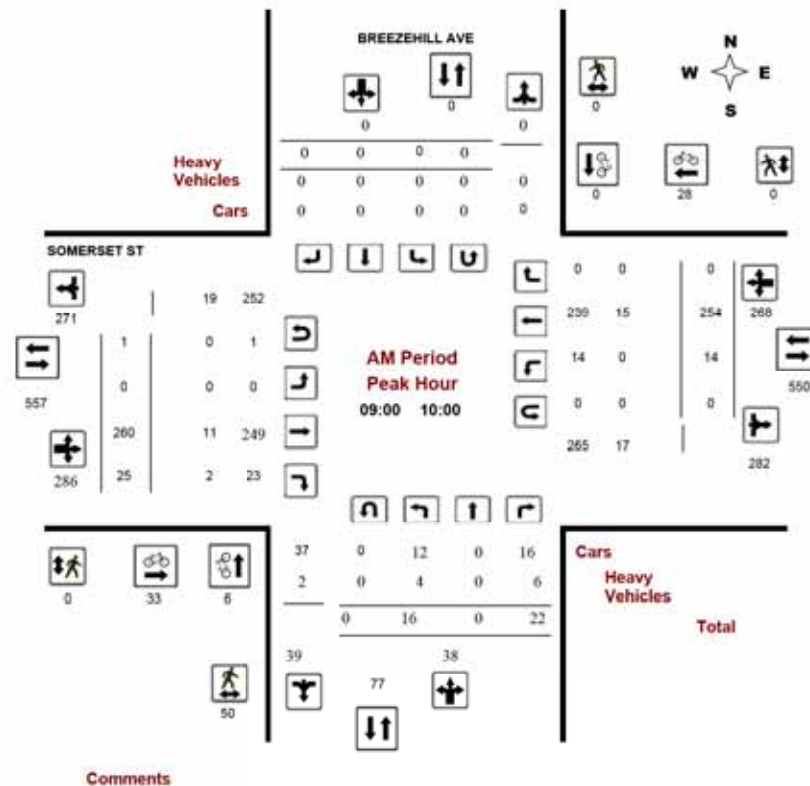





# Transportation Services - Traffic Services

## Turning Movement Count - Peak Hour Diagram

### BREEZEHILL AVE @ SOMERSET ST

Survey Date: Thursday, August 13, 2015

Start Time: 07:00

WO No: 35301

Device: Miovision

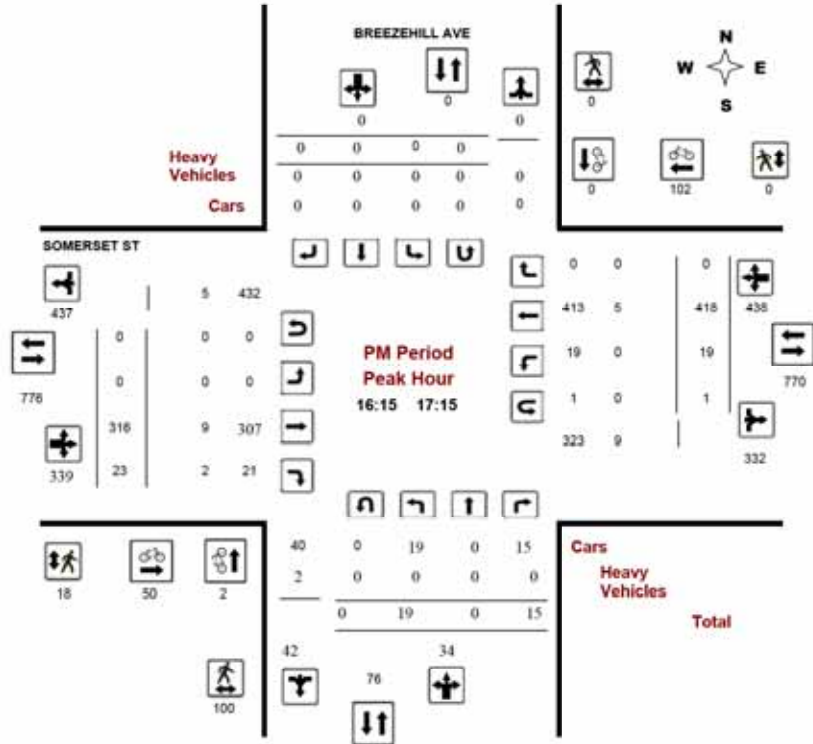

Comments



# Transportation Services - Traffic Services

Work Order 35301

## Turning Movement Count - 15 Min U-Turn Total Report

### BREEZEHILL AVE @ SOMERSET ST

Survey Date: Thursday, August 13, 2015

Time Period	Northbound U-Turn Total	Southbound U-Turn Total	Eastbound U-Turn Total	Westbound U-Turn Total	Total
07:00 - 07:15	0	0	0	0	0
07:15 - 07:30	0	0	0	0	0
07:30 - 07:45	0	0	0	0	0
07:45 - 08:00	0	0	0	0	0
08:00 - 08:15	0	0	0	0	0
08:15 - 08:30	0	0	0	0	0
08:30 - 08:45	0	0	0	0	0
08:45 - 09:00	0	0	0	0	0
09:00 - 09:15	0	0	0	0	0
09:15 - 09:30	0	0	0	0	0
09:30 - 09:45	0	0	0	0	0
09:45 - 10:00	0	0	1	0	1
11:30 - 11:45	0	0	0	0	0
11:45 - 12:00	0	0	0	0	0
12:00 - 12:15	0	0	0	0	0
12:15 - 12:30	0	0	1	0	1
12:30 - 12:45	0	0	0	0	0
12:45 - 13:00	0	0	0	0	0
13:00 - 13:15	0	0	0	0	0
13:15 - 13:30	0	0	0	0	0
15:00 - 15:15	0	0	0	0	0
15:15 - 15:30	0	0	0	0	0
15:30 - 15:45	0	0	0	0	0
15:45 - 16:00	0	0	1	0	1
16:00 - 16:15	0	0	0	0	0
16:15 - 16:30	0	0	0	0	0
16:30 - 16:45	0	0	0	1	1
16:45 - 17:00	0	0	0	0	0
17:00 - 17:15	0	0	0	0	0
17:15 - 17:30	0	0	0	1	1
17:30 - 17:45	0	0	1	0	1
17:45 - 18:00	0	0	0	0	0
<b>Total</b>	<b>0</b>	<b>0</b>	<b>4</b>	<b>2</b>	<b>6</b>



### Turning Movement Count Summary, AM and PM Peak Hour Flow Diagrams

Automobiles, Taxis, Light Trucks, Vans, SUV's, Motorcycles, Heavy Trucks, Buses, and School Buses

#### Gladstone Avenue & Loretta Avenue North Ottawa, ON

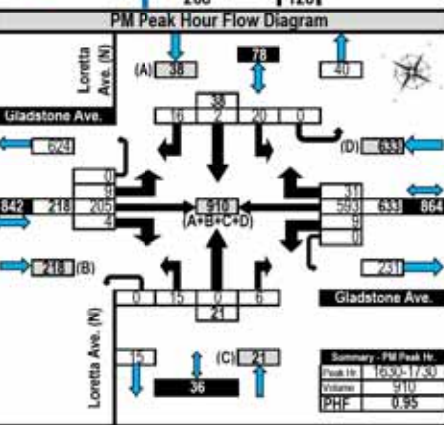
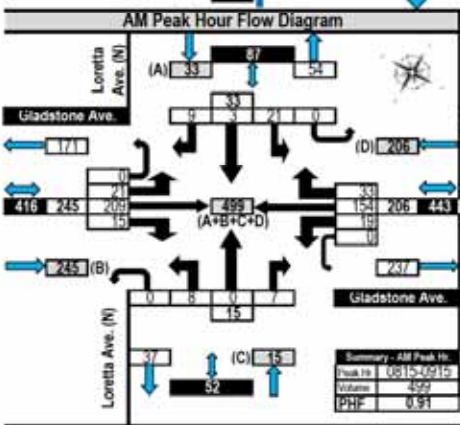
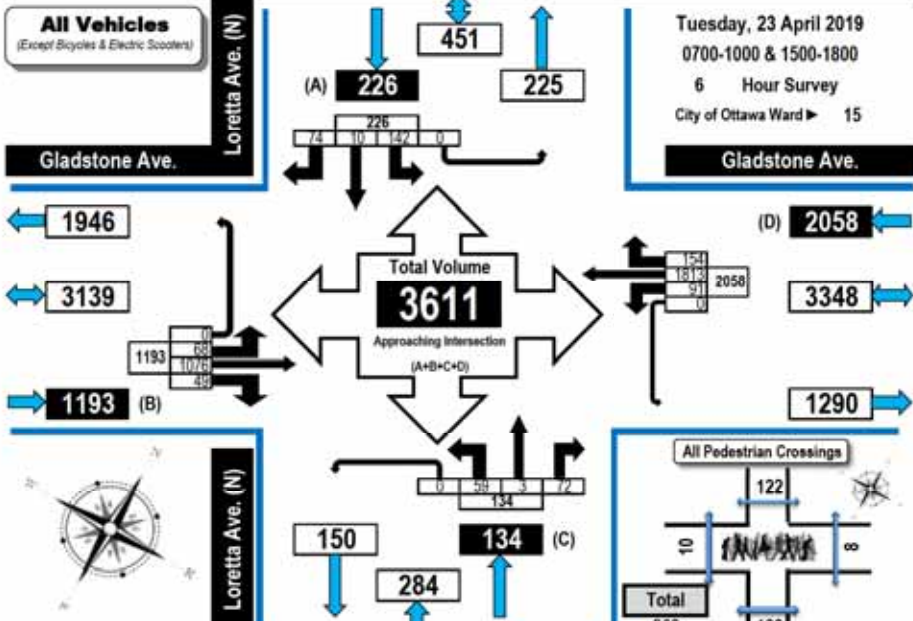

### Turning Movement Count Summary Report AADT and Expansion Factors

Automobiles, Taxis, Light Trucks, Vans, SUV's, Motorcycles, Heavy Trucks, Buses, and School Buses

#### Gladstone Avenue & Loretta Avenue North Ottawa, ON

Survey Date: Tuesday, 23 April 2019 Start Time: 0700 AADT Factor: 0.7  
 Weather AM: Partly Cloudy +10°C Survey Duration: 6 Hrs. Survey Hours: 0700-1000 & 1500-1800  
 Weather PM: Overcast +17°C Surveyor(s): Carmody

Time Period	Gladstone Ave. Eastbound					Gladstone Ave. Westbound					Loretta Ave. (N) Northbound					Loretta Ave. (N) Southbound					
	LT	ST	RT	UT	TOT	LT	ST	RT	UT	TOT	LT	ST	RT	UT	TOT	LT	ST	RT	UT	TOT	
0700-0800	6	142	18	0	166	22	112	24	0	158	324	1	0	6	0	7	13	3	4	0	20
0800-0900	17	214	9	0	240	19	140	35	0	194	434	8	0	10	0	18	20	2	3	0	25
0900-1000	16	168	11	0	195	24	160	27	0	211	406	2	0	7	0	9	14	2	11	0	27
1500-1600	10	174	5	0	189	13	356	22	0	393	582	20	1	35	0	62	39	1	24	0	64
1600-1700	9	188	2	0	199	4	525	18	0	547	746	11	1	10	0	22	37	1	20	0	58
1700-1800	10	190	4	0	204	9	518	28	0	555	759	11	1	4	0	16	19	1	12	0	32
<b>Totals</b>	<b>68</b>	<b>1076</b>	<b>49</b>	<b>0</b>	<b>1193</b>	<b>91</b>	<b>1813</b>	<b>154</b>	<b>0</b>	<b>2058</b>	<b>3251</b>	<b>59</b>	<b>3</b>	<b>72</b>	<b>0</b>	<b>134</b>	<b>142</b>	<b>10</b>	<b>74</b>	<b>0</b>	<b>226</b>

**Equivalent 12 & 24-hour Vehicle Volumes Including the Annual Average Daily Traffic (AADT) Factor**  
 Applicable to the Day and Month of the Turning Movement Count

**Expansion factors are applied exclusively to standard weekday 8-hour turning movement counts conducted during the hours of 0700h - 1000h, 1130h - 1330h and 1500h - 1800h**

Time Period	LT	ST	RT	UT	TOT	LT	ST	RT	UT	TOT	LT	ST	RT	UT	TOT	LT	ST	RT	UT	TOT
Equ. 12 Hr	n/a	n/a	n/a	n/a	n/a	n/a	n/a	n/a	n/a	n/a	n/a	n/a	n/a	n/a	n/a	n/a	n/a	n/a	n/a	n/a
AADT 12-hr	n/a	n/a	n/a	n/a	n/a	n/a	n/a	n/a	n/a	n/a	n/a	n/a	n/a	n/a	n/a	n/a	n/a	n/a	n/a	n/a
AADT 24 Hr	n/a	n/a	n/a	n/a	n/a	n/a	n/a	n/a	n/a	n/a	n/a	n/a	n/a	n/a	n/a	n/a	n/a	n/a	n/a	n/a

#### AADT and expansion factors provided by the City of Ottawa

AM Peak Hr	LT	ST	RT	UT	TOT	LT	ST	RT	UT	TOT	LT	ST	RT	UT	TOT	LT	ST	RT	UT	TOT	
0815-0915	21	209	15	0	245	19	154	33	0	206	451	8	0	7	0	15	21	3	9	0	33

PM Peak Hr	LT	ST	RT	UT	TOT	LT	ST	RT	UT	TOT	LT	ST	RT	UT	TOT	LT	ST	RT	UT	TOT	
1630-1730	9	205	4	0	218	9	593	31	0	633	851	15	0	6	0	21	20	2	16	0	38

**Comments:**  
 No traffic issues noted during survey.

**Notes:**  
 1. Includes all vehicle types except bicycles, electric bicycles, and electric scooters.  
 2. When expansion and AADT factors are applied, the results will differ slightly due to rounding.



## Turning Movement Count Pedestrian Crossings Summary and Flow Diagram



Gladstone Avenue & Loretta Avenue North Ottawa, ON

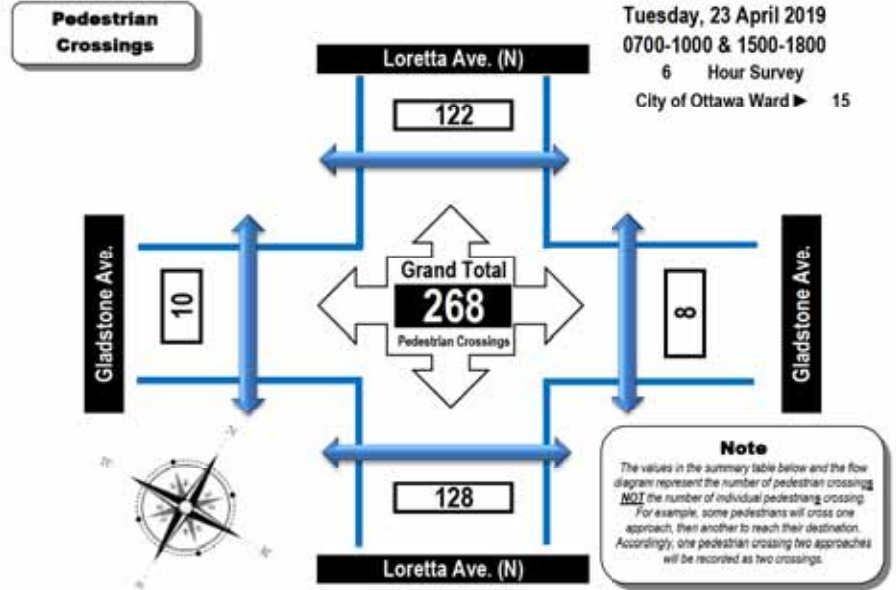

Time Period	West Side Crossing Gladstone Ave.	East Side Crossing Gladstone Ave.	Street Total	South Side Crossing Loretta Ave. (N)	North Side Crossing Loretta Ave. (N)	Street Total	Grand Total
0700-0800	6	2	8	13	15	28	36
0800-0900	2	2	4	14	16	30	34
0900-1000	0	0	0	16	17	33	33
1500-1600	0	1	1	24	23	47	48
1600-1700	0	0	0	27	28	55	55
1700-1800	2	3	5	34	23	57	62
<b>Totals</b>	<b>10</b>	<b>8</b>	<b>18</b>	<b>128</b>	<b>122</b>	<b>250</b>	<b>268</b>

Comments:  
No traffic issues noted during survey.



## Turning Movement Count Bicycle Summary Flow Diagram



Gladstone Avenue & Loretta Avenue North Ottawa, ON

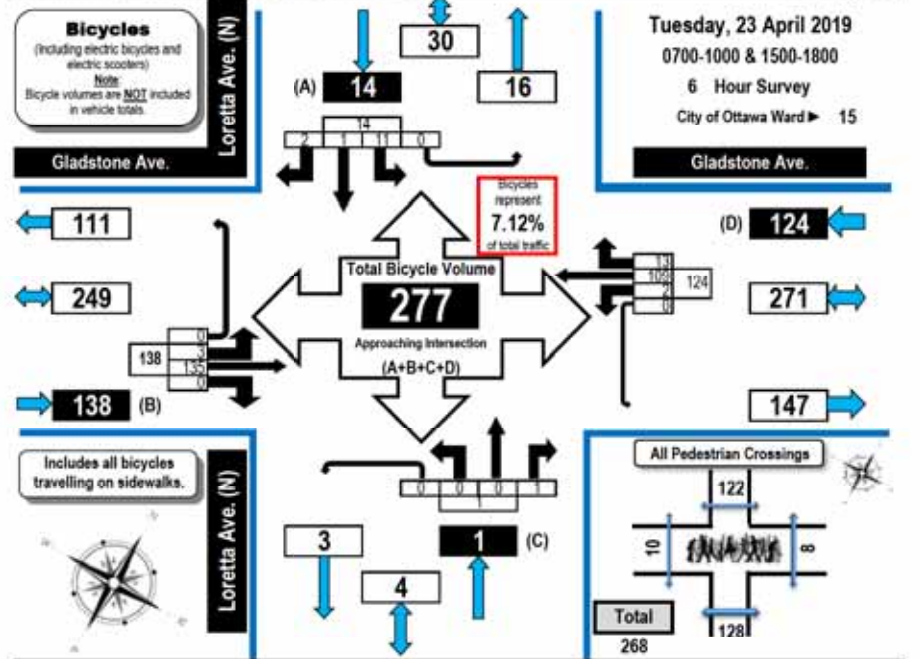

Time Period	Gladstone Ave. Eastbound					Gladstone Ave. Westbound					Loretta Ave. (N) Northbound					Loretta Ave. (N) Southbound					G.Tot.
	LT	ST	RT	UT	S.Tot.	LT	ST	RT	UT	S.Tot.	LT	ST	RT	UT	S.Tot.	LT	ST	RT	UT	S.Tot.	
0700-0800	0	26	0	0	26	0	9	1	0	10	0	0	0	0	0	1	1	0	0	2	38
0800-0900	1	55	0	0	56	1	15	2	0	18	0	0	1	0	1	7	0	0	0	7	82
0900-1000	0	15	0	0	15	0	8	0	0	8	0	0	0	0	0	1	0	0	0	1	24
1500-1600	1	10	0	0	11	0	14	1	0	15	0	0	0	0	0	1	0	1	0	2	28
1600-1700	1	17	0	0	18	1	29	2	0	32	0	0	0	0	0	1	0	0	0	1	51
1700-1800	0	12	0	0	12	0	34	7	0	41	0	0	0	0	0	0	0	1	0	1	54
<b>Totals</b>	<b>3</b>	<b>135</b>	<b>0</b>	<b>0</b>	<b>138</b>	<b>2</b>	<b>109</b>	<b>13</b>	<b>0</b>	<b>124</b>	<b>0</b>	<b>0</b>	<b>1</b>	<b>0</b>	<b>1</b>	<b>11</b>	<b>1</b>	<b>2</b>	<b>0</b>	<b>14</b>	<b>277</b>

Comments:  
No traffic issues noted during survey.



### Turning Movement Count Heavy Vehicle Summary Flow Diagram

Heavy Trucks, Buses,  
and School Buses

#### Gladstone Avenue & Loretta Avenue North Ottawa, ON

**Heavy Vehicles**  
(Construction Vehicles, Heavy Trucks, Buses & School Buses).  
Heavy vehicle totals **ARE** included in all vehicles summary and flow diagrams.

Gladstone Ave.

Loretta Ave. (N)

Tuesday, 23 April 2019  
0700-1000 & 1500-1800  
6 Hour Survey  
City of Ottawa Ward 15

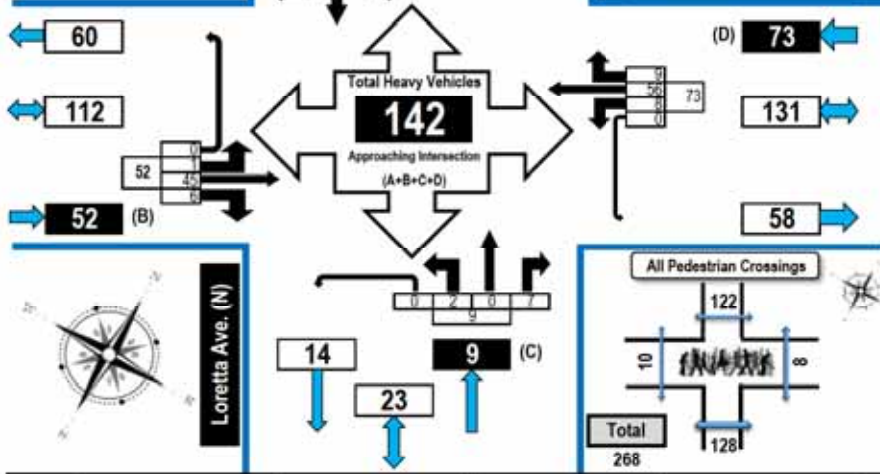

Gladstone Ave. Eastbound					Gladstone Ave. Westbound					Loretta Ave. (N) Northbound					Loretta Ave. (N) Southbound				
LT	ST	RT	UT	S. Tot	LT	ST	RT	UT	S. Tot	LT	ST	RT	UT	S. Tot	LT	ST	RT	UT	S. Tot

0700-0800	0	6	2	0	8	1	7	1	0	9	0	0	1	0	1	0	0	0	0	18
0800-0900	0	8	1	0	9	0	10	3	0	13	0	0	4	0	4	2	0	0	0	28
0900-1000	1	14	1	0	16	2	15	3	0	20	0	0	0	0	0	1	0	2	0	39
1500-1600	0	6	1	0	7	3	7	1	0	11	0	0	2	0	2	1	0	0	0	21
1600-1700	0	5	1	0	6	1	10	0	0	11	2	0	0	0	2	1	0	0	0	20
1700-1800	0	6	0	0	6	1	7	1	0	9	0	0	0	0	0	1	0	0	0	16
<b>Totals</b>	<b>1</b>	<b>45</b>	<b>6</b>	<b>0</b>	<b>52</b>	<b>8</b>	<b>56</b>	<b>9</b>	<b>0</b>	<b>73</b>	<b>2</b>	<b>0</b>	<b>7</b>	<b>0</b>	<b>9</b>	<b>6</b>	<b>0</b>	<b>2</b>	<b>0</b>	<b>142</b>

Comments:  
No traffic issues noted during survey.



### Transportation Services - Traffic Services w.o. 37132 Turning Movement Count - 15 Minute Summary Report

#### GLADSTONE AVE @ PRESTON ST

Survey Date: Tuesday, June 20, 2017  
Total Observed U-Turns:  
Northbound: 0 Southbound: 0  
Eastbound: 1 Westbound: 0

Time Period	PRESTON ST Northbound				PRESTON ST Southbound				GLADSTONE AVE Eastbound				GLADSTONE AVE Westbound				Grand Total		
	LT	ST	RT	TOT	LT	ST	RT	TOT	LT	ST	RT	TOT	LT	ST	RT	TOT			
07:00-07:15	12	66	16	94	12	82	2	96	190	4	25	10	39	10	27	19	56	95	285
07:15-07:30	3	78	19	100	14	104	3	121	221	2	24	8	34	10	23	12	45	79	300
07:30-07:45	13	85	15	113	10	70	4	84	197	3	29	13	45	8	25	12	45	90	287
07:45-08:00	13	95	15	123	17	90	7	114	237	11	32	10	53	13	24	14	51	104	341
08:00-08:15	12	99	17	128	19	85	3	107	235	7	39	16	62	13	28	21	62	124	359
08:15-08:30	14	100	27	141	18	91	10	119	260	9	56	19	84	17	40	17	74	158	418
08:30-08:45	9	120	21	150	20	81	3	114	264	5	52	14	71	6	49	14	69	140	404
08:45-09:00	10	94	16	120	16	78	0	94	214	10	50	13	73	12	41	16	69	142	356
09:00-09:15	13	81	20	114	21	106	10	139	253	5	27	13	45	12	35	17	64	109	362
09:15-09:30	19	61	18	98	23	94	8	125	223	8	27	12	47	12	40	21	73	120	343
09:30-09:45	14	79	17	110	24	84	11	119	229	9	25	10	45	21	26	15	62	107	336
09:45-10:00	9	73	19	101	18	75	3	94	195	4	30	11	45	11	38	17	66	111	306
11:30-11:45	8	70	20	98	20	63	4	87	185	5	24	14	43	29	22	20	71	114	299
11:45-12:00	9	67	23	99	15	69	13	117	216	2	36	12	52	27	53	27	107	159	375
12:00-12:15	13	79	21	113	11	84	11	106	219	5	35	13	53	30	41	28	99	152	371
12:15-12:30	11	89	25	125	16	67	5	88	213	5	35	14	54	22	44	29	95	149	362
12:30-12:45	7	53	19	79	18	67	11	126	205	6	33	13	52	21	34	27	82	134	339
12:45-13:00	16	63	27	106	21	77	4	102	208	8	32	19	59	22	44	25	91	150	358
13:00-13:15	13	89	19	121	14	83	9	106	227	9	40	19	68	24	44	21	89	157	384
13:15-13:30	12	73	22	107	29	75	8	112	219	10	35	11	56	21	41	21	83	139	358
15:00-15:15	15	84	29	128	8	95	8	111	239	5	39	26	70	24	62	27	113	183	422
15:15-15:30	21	118	24	163	17	97	9	123	286	6	40	11	57	16	64	15	95	152	438
15:30-15:45	12	98	16	126	13	73	10	96	222	5	39	14	58	26	92	20	138	196	418
15:45-16:00	13	108	16	137	12	86	6	104	241	10	48	14	72	19	96	15	130	202	443
16:00-16:15	27	118	19	164	15	83	9	107	271	4	40	8	52	22	97	14	133	185	456
16:15-16:30	14	104	22	140	12	95	10	117	257	3	48	11	62	18	107	20	145	207	464
16:30-16:45	16	83	29	128	9	86	8	103	231	6	51	13	70	24	101	20	145	215	446
16:45-17:00	22	92	23	137	15	103	10	128	265	3	43	6	52	18	114	24	156	208	473
17:00-17:15	24	95	27	146	16	80	21	117	263	8	45	8	61	20	117	13	150	211	474
17:15-17:30	12	79	24	115	7	85	8	100	215	1	40	9	50	24	100	20	144	194	409
17:30-17:45	13	86	31	130	15	71	7	93	223	8	48	8	64	26	85	25	136	200	423
17:45-18:00	13	84	12	109	6	84	11	111	220	8	45	12	65	27	78	20	125	190	410
<b>TOTAL:</b>	<b>432</b>	<b>2763</b>	<b>668</b>	<b>3863</b>	<b>499</b>	<b>2735</b>	<b>246</b>	<b>3480</b>	<b>7343</b>	<b>194</b>	<b>1214</b>	<b>404</b>	<b>1813</b>	<b>605</b>	<b>1832</b>	<b>626</b>	<b>3063</b>	<b>4876</b>	<b>12219</b>

Note: U-Turns are included in Totals. Comment:



**Transportation Services - Traffic Services**  
**Turning Movement Count - Cyclist Volume Report**

Work Order  
37132

**GLADSTONE AVE @ PRESTON ST**

Count Date: Tuesday, June 20, 2017

Start Time: 07:00

Time Period	PRESTON ST			GLADSTONE AVE			Grand Total
	Northbound	Southbound	Street Total	Eastbound	Westbound	Street Total	
07:00 08:00	0	8	8	19	14	33	41
08:00 09:00	10	14	24	47	25	72	96
09:00 10:00	7	8	15	15	21	36	51
11:30 12:30	5	9	14	10	8	18	32
12:30 13:30	8	10	18	4	14	18	36
15:00 16:00	8	8	16	17	15	32	48
16:00 17:00	11	13	24	20	42	62	86
17:00 18:00	7	8	15	27	38	65	80
<b>Total</b>	<b>56</b>	<b>78</b>	<b>134</b>	<b>159</b>	<b>177</b>	<b>336</b>	<b>470</b>

Comment:

Note: These volumes consists of bicycles only (no mopeds or motorcycles) and ARE NOT included in the Turning Movement Count Summary.



**Transportation Services - Traffic Services**  
**Turning Movement Count - Full Study Diagram**

**GLADSTONE AVE @ PRESTON ST**

Survey Date: Tuesday, June 20, 2017

WO#: 37132  
Device: Miovision

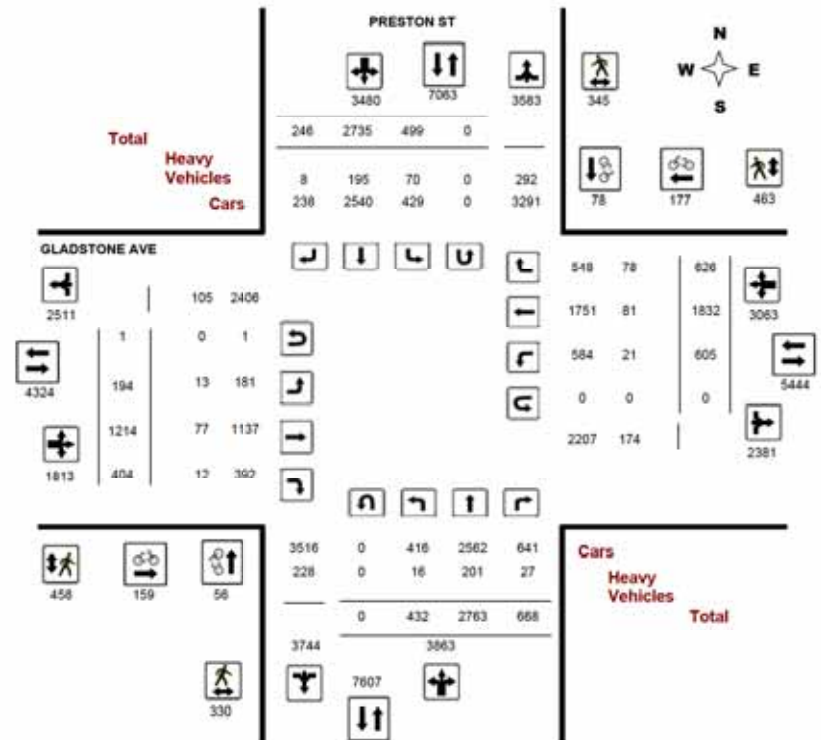

Comments



# Transportation Services - Traffic Services

W.O.  
37132

## Turning Movement Count - Heavy Vehicle Report

### GLADSTONE AVE @ PRESTON ST

Survey Date: Tuesday, June 20, 2017

Time Period	PRESTON ST									GLADSTONE AVE									Grand Total
	Northbound			Southbound			S TOT	STR TOT	Eastbound			Westbound			W TOT	STR TOT			
	LT	ST	RT	LT	ST	RT			LT	ST	RT	LT	ST	RT					
07:00 08:00	1	26	5	32	13	22	1	36	68	2	12	1	15	0	9	5	14	29	97
08:00 09:00	1	28	5	34	11	26	0	37	71	4	10	3	17	4	12	10	26	43	114
09:00 10:00	4	33	5	42	12	40	0	52	94	2	12	4	18	3	13	12	28	46	140
11:30 12:30	1	25	2	28	8	29	4	39	67	1	9	1	11	3	9	14	26	37	104
12:30 13:30	5	27	2	34	15	22	0	37	71	1	10	2	13	7	11	11	29	42	113
15:00 16:00	3	27	4	34	3	24	3	30	64	3	6	1	10	3	12	8	23	33	97
16:00 17:00	1	21	3	25	7	18	0	25	50	0	11	0	11	0	9	11	20	31	81
17:00 18:00	0	14	1	15	3	14	0	17	32	0	7	0	7	1	6	7	14	21	53
<b>Sub Total</b>	<b>16</b>	<b>201</b>	<b>27</b>	<b>244</b>	<b>70</b>	<b>195</b>	<b>8</b>	<b>273</b>	<b>517</b>	<b>13</b>	<b>77</b>	<b>12</b>	<b>102</b>	<b>21</b>	<b>81</b>	<b>78</b>	<b>180</b>	<b>282</b>	<b>799</b>
<b>U-Turns (Heavy Vehicles)</b>	<b>0</b>									<b>0</b>									<b>0</b>
<b>Total</b>	<b>16</b>	<b>201</b>	<b>27</b>	<b>244</b>	<b>70</b>	<b>195</b>	<b>8</b>	<b>273</b>	<b>517</b>	<b>13</b>	<b>77</b>	<b>12</b>	<b>102</b>	<b>21</b>	<b>81</b>	<b>78</b>	<b>180</b>	<b>282</b>	<b>799</b>

Heavy Vehicles include Buses, Single-Unit Trucks and Articulated Trucks. Further, they ARE included in the Turning Movement Count Summary.



# Transportation Services - Traffic Services

Work Order  
37132

## Turning Movement Count - Pedestrian Volume Report

### GLADSTONE AVE @ PRESTON ST

Count Date: Tuesday, June 20, 2017

Start Time: 07:00

Time Period	NB Approach (E or W Crossing)	SB Approach (E or W Crossing)	Total	EB Approach (N or S Crossing)	WB Approach (N or S Crossing)	Total	Grand Total
07:00 07:15	1	3	4	1	3	4	8
07:15 07:30	7	5	12	3	4	7	19
07:30 07:45	7	10	17	8	12	20	37
07:45 08:00	19	6	25	12	14	26	51
<b>07:00 08:00</b>	<b>34</b>	<b>24</b>	<b>58</b>	<b>24</b>	<b>33</b>	<b>57</b>	<b>115</b>
08:00 08:15	10	7	17	9	16	25	42
08:15 08:30	8	9	17	4	15	19	36
08:30 08:45	26	22	48	21	40	61	109
08:45 09:00	13	16	29	10	23	33	62
<b>08:00 09:00</b>	<b>57</b>	<b>54</b>	<b>111</b>	<b>44</b>	<b>94</b>	<b>138</b>	<b>249</b>
09:00 09:15	12	6	18	3	9	12	30
09:15 09:30	8	8	14	5	14	19	33
09:30 09:45	4	9	13	9	3	12	25
09:45 10:00	9	10	19	10	12	22	41
<b>09:00 10:00</b>	<b>33</b>	<b>31</b>	<b>64</b>	<b>27</b>	<b>38</b>	<b>65</b>	<b>129</b>
11:30 11:45	9	4	13	8	14	22	35
11:45 12:00	8	9	17	11	9	20	37
12:00 12:15	14	13	27	18	13	31	58
12:15 12:30	14	9	23	27	8	35	58
<b>11:30 12:30</b>	<b>45</b>	<b>35</b>	<b>80</b>	<b>64</b>	<b>44</b>	<b>108</b>	<b>188</b>
12:30 12:45	10	9	19	16	20	36	55
12:45 13:00	8	8	16	13	16	29	45
13:00 13:15	6	11	17	20	14	34	51
13:15 13:30	4	6	10	12	12	24	34
<b>12:30 13:30</b>	<b>28</b>	<b>34</b>	<b>62</b>	<b>61</b>	<b>62</b>	<b>123</b>	<b>185</b>
15:00 15:15	6	7	13	16	14	30	43
15:15 15:30	9	11	20	10	19	29	49
15:30 15:45	10	5	15	17	11	28	43
15:45 16:00	21	11	32	11	13	24	56
<b>15:00 16:00</b>	<b>46</b>	<b>34</b>	<b>80</b>	<b>54</b>	<b>57</b>	<b>111</b>	<b>191</b>
16:00 16:15	8	14	22	22	14	36	58
16:15 16:30	10	15	25	20	16	36	61
16:30 16:45	10	16	26	33	22	55	81
16:45 17:00	16	12	28	28	12	40	68
<b>16:00 17:00</b>	<b>44</b>	<b>57</b>	<b>101</b>	<b>103</b>	<b>64</b>	<b>167</b>	<b>268</b>
17:00 17:15	15	18	31	23	18	41	72
17:15 17:30	13	17	30	18	22	40	70
17:30 17:45	9	18	27	13	8	21	48
17:45 18:00	6	25	31	27	23	50	81
<b>17:00 18:00</b>	<b>43</b>	<b>76</b>	<b>119</b>	<b>81</b>	<b>71</b>	<b>152</b>	<b>271</b>
<b>Total</b>	<b>330</b>	<b>345</b>	<b>675</b>	<b>458</b>	<b>463</b>	<b>921</b>	<b>1596</b>

Comment:



# Transportation Services - Traffic Services

Work Order  
37132

## Turning Movement Count - Full Study Summary Report

### GLADSTONE AVE @ PRESTON ST

Survey Date: Tuesday, June 20, 2017

<b>Total Observed U-Turns</b>		<b>AADT Factor</b>
Northbound: 0	Southbound: 0	.90
Eastbound: 1	Westbound: 0	

#### Full Study

Period	PRESTON ST								GLADSTONE AVE								Grand Total		
	Northbound				Southbound				Eastbound				Westbound						
	LT	ST	RT	NB TOT	LT	ST	RT	SB TOT	STR TOT	LT	ST	RT	EB TOT	LT	ST	RT		WB TOT	
07:00-08:00	41	324	65	430	53	345	16	415	845	20	110	41	171	41	99	57	197	368	1213
08:00-09:00	45	413	81	539	73	345	16	434	973	31	197	62	290	48	158	66	274	564	1537
09:00-10:00	55	294	74	423	84	361	32	477	900	26	109	48	181	58	139	70	285	448	1346
11:30-12:30	41	305	89	435	62	303	33	398	833	17	132	53	202	108	160	104	372	574	1467
12:30-13:30	48	278	87	413	62	332	32	446	859	33	140	62	235	60	163	94	345	580	1439
15:00-16:00	81	408	85	554	50	351	33	434	888	26	166	85	257	85	314	77	476	733	1721
16:00-17:00	79	397	93	569	51	367	37	455	1024	16	182	38	236	82	419	78	579	815	1839
17:00-18:00	62	344	94	500	44	330	47	421	921	25	178	37	240	97	380	78	555	795	1716
<b>Sub Total</b>	<b>432</b>	<b>2763</b>	<b>668</b>	<b>3863</b>	<b>499</b>	<b>2735</b>	<b>246</b>	<b>3480</b>	<b>7343</b>	<b>194</b>	<b>1214</b>	<b>404</b>	<b>1812</b>	<b>605</b>	<b>1832</b>	<b>626</b>	<b>3063</b>	<b>4875</b>	<b>12218</b>
<b>U Turns</b>				<b>0</b>				<b>0</b>	<b>0</b>				<b>1</b>				<b>0</b>	<b>1</b>	<b>1</b>
<b>Total</b>	<b>432</b>	<b>2763</b>	<b>668</b>	<b>3863</b>	<b>499</b>	<b>2735</b>	<b>246</b>	<b>3480</b>	<b>7343</b>	<b>194</b>	<b>1214</b>	<b>404</b>	<b>1813</b>	<b>605</b>	<b>1832</b>	<b>626</b>	<b>3063</b>	<b>4876</b>	<b>12219</b>

EQ 12hr 600 3841 920 5378 694 3602 342 4837 16207 270 1687 582 2526 841 2546 670 4258 6778 16985

Note: These values are calculated by multiplying the totals by the appropriate expansion factor. **1.39**

AVG 12hr 540 3457 836 4833 634 3421 308 4353 9186 243 1519 505 2268 757 2292 783 3832 6100 15286

Note: These volumes are calculated by multiplying the Equivalent 12 hr. totals by the AADT factor. **.90**

AVG 24hr 708 4528 1095 6331 818 4482 403 5793 12634 318 1900 662 2971 991 3002 1026 5628 7991 20625

Note: These volumes are calculated by multiplying the Average Daily 12 hr. totals by 12 to 24 expansion factor. **1.31**

#### Comments:

Note: U-Turns provided for approach totals. Refer to 'U-Turn' Report for specific breakdown.



# Transportation Services - Traffic Services

## Turning Movement Count - Peak Hour Diagram

### GLADSTONE AVE @ PRESTON ST

Survey Date: Tuesday, June 20, 2017

WO No: 37132

Start Time: 07:00

Device: Miovision

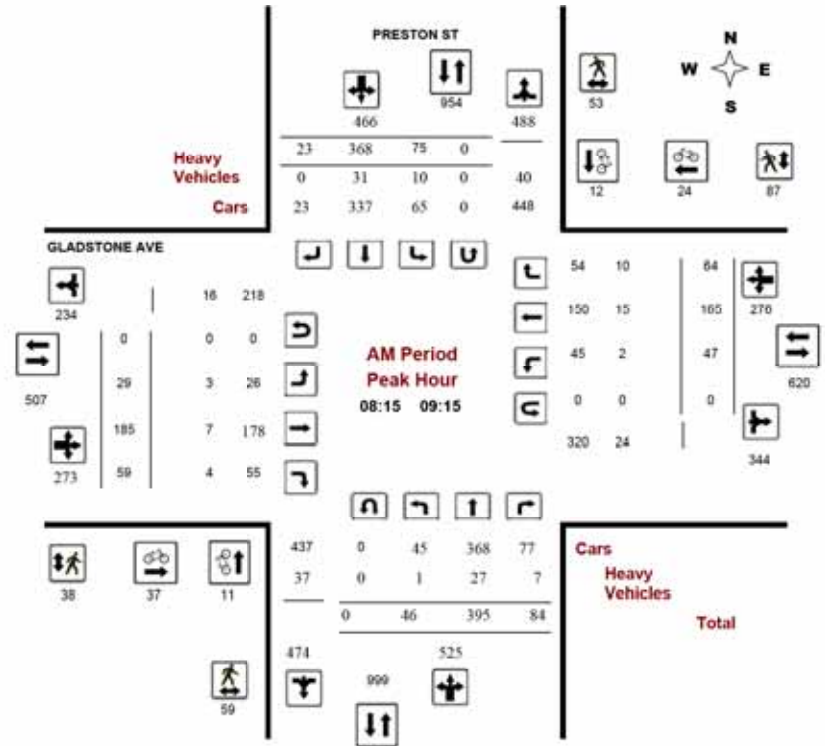



### Transportation Services - Traffic Services

#### Turning Movement Count - Peak Hour Diagram

#### GLADSTONE AVE @ PRESTON ST

Survey Date: Tuesday, June 20, 2017

Start Time: 07:00

WO No: 37132

Device: Miovision

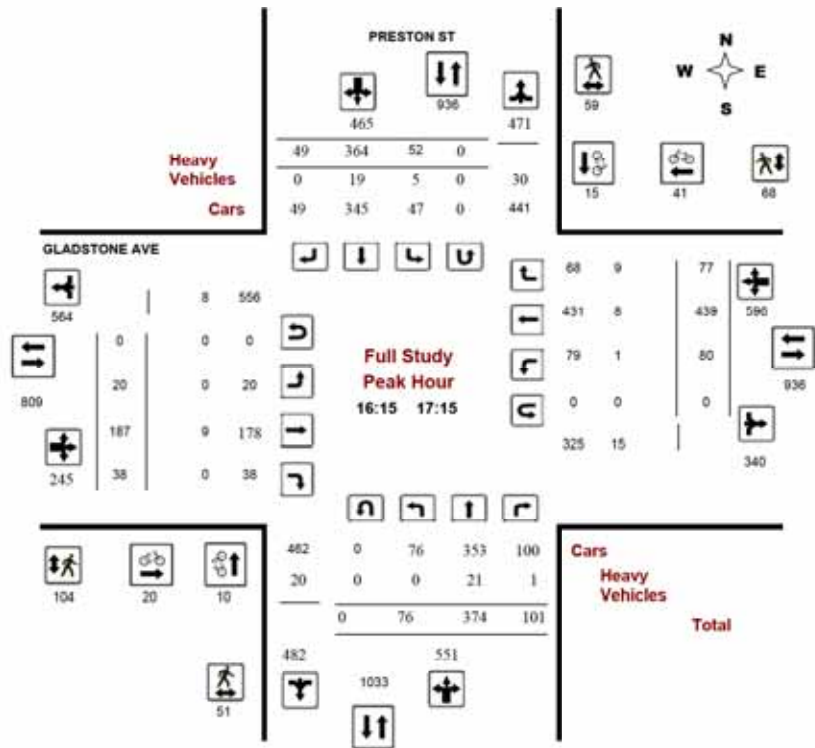

### Transportation Services - Traffic Services

#### Turning Movement Count - Peak Hour Diagram

#### GLADSTONE AVE @ PRESTON ST

Survey Date: Tuesday, June 20, 2017

Start Time: 07:00

WO No: 37132

Device: Miovision

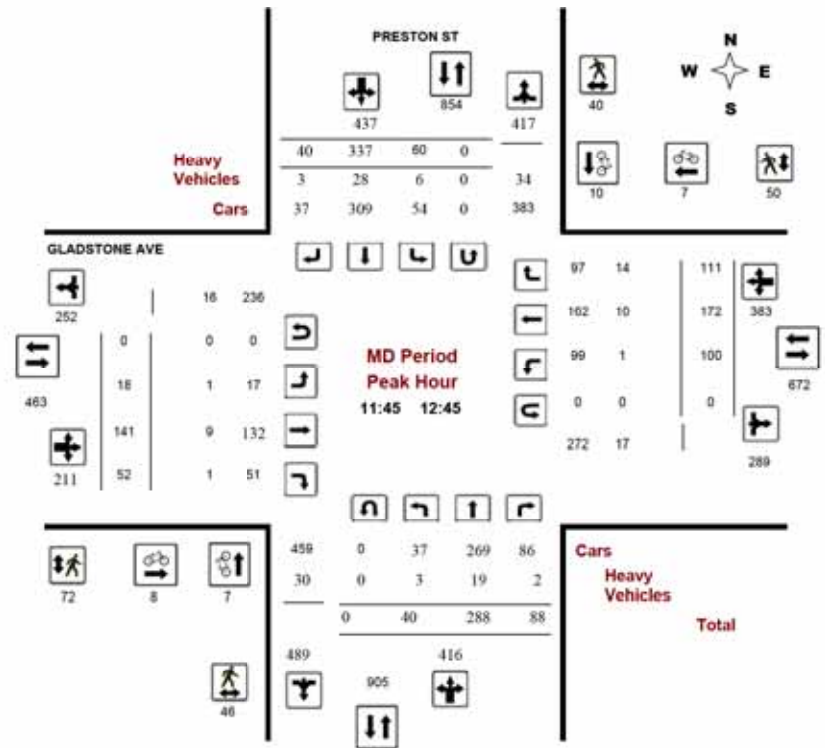



# Transportation Services - Traffic Services

## Turning Movement Count - Peak Hour Diagram

### GLADSTONE AVE @ PRESTON ST

Survey Date: Tuesday, June 20, 2017

Start Time: 07:00

WO No: 37132

Device: Miovision

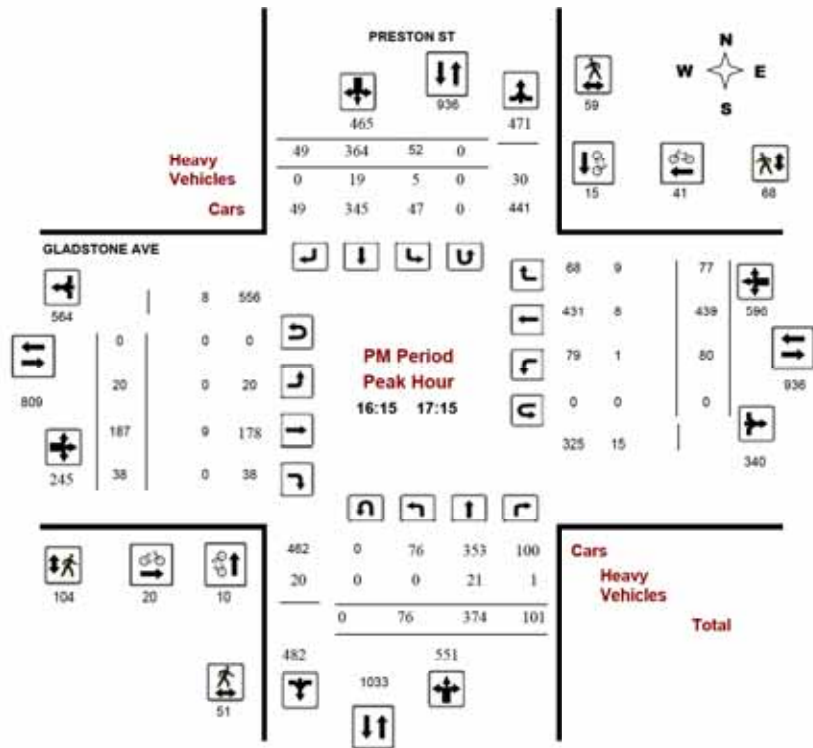

# Transportation Services - Traffic Services

Work Order 37132

## Turning Movement Count - 15 Min U-Turn Total Report

### GLADSTONE AVE @ PRESTON ST

Survey Date: Tuesday, June 20, 2017

Time Period	Northbound U-Turn Total	Southbound U-Turn Total	Eastbound U-Turn Total	Westbound U-Turn Total	Total
07:00 - 07:15	0	0	0	0	0
07:15 - 07:30	0	0	0	0	0
07:30 - 07:45	0	0	0	0	0
07:45 - 08:00	0	0	0	0	0
08:00 - 08:15	0	0	0	0	0
08:15 - 08:30	0	0	0	0	0
08:30 - 08:45	0	0	0	0	0
08:45 - 09:00	0	0	0	0	0
09:00 - 09:15	0	0	0	0	0
09:15 - 09:30	0	0	0	0	0
09:30 - 09:45	0	0	1	0	1
09:45 - 10:00	0	0	0	0	0
11:30 - 11:45	0	0	0	0	0
11:45 - 12:00	0	0	0	0	0
12:00 - 12:15	0	0	0	0	0
12:15 - 12:30	0	0	0	0	0
12:30 - 12:45	0	0	0	0	0
12:45 - 13:00	0	0	0	0	0
13:00 - 13:15	0	0	0	0	0
13:15 - 13:30	0	0	0	0	0
15:00 - 15:15	0	0	0	0	0
15:15 - 15:30	0	0	0	0	0
15:30 - 15:45	0	0	0	0	0
15:45 - 16:00	0	0	0	0	0
16:00 - 16:15	0	0	0	0	0
16:15 - 16:30	0	0	0	0	0
16:30 - 16:45	0	0	0	0	0
16:45 - 17:00	0	0	0	0	0
17:00 - 17:15	0	0	0	0	0
17:15 - 17:30	0	0	0	0	0
17:30 - 17:45	0	0	0	0	0
17:45 - 18:00	0	0	0	0	0
<b>Total</b>	<b>0</b>	<b>0</b>	<b>1</b>	<b>0</b>	<b>1</b>

# Appendix C

Synchro Intersection Worksheets – Existing Conditions

951 Gladstone & 145 Loretta  
Existing - AM Peak Hour

951 Gladstone & 145 Loretta  
Existing - AM Peak Hour

951 Gladstone & 145 Loretta  
Existing - AM Peak Hour

Lanes, Volumes, Timings  
2: Preston & Gladstone

951 Gladstone & 145 Loretta  
Existing - AM Peak Hour

Intersection	1.5											
Initial Delay, s/veh	1.5											
Movement	EBL	EBT	EBR	WBL	WBT	WBR	NBL	NBT	NBR	SBT	SBR	
Lane Configurations	23	223	0	1	129	41	2	1	5	17	0	23
Traffic Vol, veh/h	23	223	0	1	129	41	2	1	5	17	0	23
Future Vol, veh/h	23	223	0	1	129	41	2	1	5	17	0	23
Conflicting Peds, #/hr	21	0	25	25	0	21	8	0	2	2	0	8
Sign Control	Free	Free	Free	Free	Free	Free	Free	Free	Free	Free	Free	Free
RT Channelized	-	-	-	-	-	-	-	-	-	-	-	-
Storage Length	-	-	-	-	-	-	-	-	-	-	-	-
Veh in Median Storage, #	-	-	-	-	-	-	-	-	-	-	-	-
Grade, %	-	-	-	-	-	-	-	-	-	-	-	-
Peak Hour Factor	90	90	90	90	90	90	90	90	90	90	90	90
Heavy Vehicles, %	2	2	2	2	2	2	2	2	2	2	2	2
Mgmt Flow	26	248	0	1	143	46	2	1	6	19	0	26
Major/Minor	Major1	Major2	Minor1	Minor2	Minor1	Minor2	Minor1	Minor2	Minor1	Minor2	Minor1	Minor2
Conflicting Flow All	210	0	0	273	0	0	514	537	275	495	514	195
Stage 1	-	-	-	-	-	-	-	325	325	-	189	189
Stage 2	-	-	-	-	-	-	-	189	212	-	306	325
Critical Hwy	4.12	-	-	4.12	-	-	7.12	6.52	6.22	7.12	6.52	6.22
Critical Hwy Stg 1	-	-	-	-	-	-	-	6.12	5.52	-	6.12	5.52
Critical Hwy Stg 2	-	-	-	-	-	-	-	6.12	5.52	-	6.12	5.52
Follow-up Hwy	2.218	-	-	2.218	-	-	3.518	4.018	3.318	3.518	4.018	3.318
Pol Cap-1 Maneuver	1361	-	-	1290	-	-	471	450	764	485	464	846
Stage 1	-	-	-	-	-	-	-	687	649	-	813	744
Stage 2	-	-	-	-	-	-	-	813	727	-	704	649
Platoon blocked, %	-	-	-	-	-	-	-	-	-	-	-	-
Mov Cap-1 Maneuver	1339	-	-	1265	-	-	437	424	748	463	437	827
Mov Cap-2 Maneuver	-	-	-	-	-	-	-	437	424	-	463	437
Stage 1	-	-	-	-	-	-	-	658	622	-	781	731
Stage 2	-	-	-	-	-	-	-	782	715	-	680	622
Approach	EB	WB	NB	WB	NB	SB	SB	SB	SB	SB	SB	SB
HCM Control Delay, s	0.7	0	0	11.2	11.2	11.3	11.3	11.3	11.3	11.3	11.3	11.3
HCM LOS	B	B	B	B	B	B	B	B	B	B	B	B
Minor Lane/Major Mvmt	NBLn1	EBL	EBT	EBR	WBL	WBT	WBR	SBLn1	SBLn1	SBLn1	SBLn1	SBLn1
Capacity (veh/h)	587	1339	-	-	1265	-	-	620	620	620	620	620
HCM Lane V/C Ratio	0.015	0.019	-	-	0.001	-	-	0.072	0.072	0.072	0.072	0.072
HCM Control Delay (s)	11.2	7.7	0	-	7.8	0	-	11.3	11.3	11.3	11.3	11.3
HCM Lane LOS	B	A	A	A	A	A	A	B	B	B	B	B
HCM 95th %ile Q(veh)	0	0.1	-	-	0	-	-	0.2	0.2	0.2	0.2	0.2

Lane Group	EBL	EBT	EBR	WBL	WBT	WBR	NBL	NBT	NBR	SBT	SBR
Lane Configurations	27	171	55	47	154	64	43	395	84	75	368
Traffic Volume (vph)	27	171	55	47	154	64	43	395	84	75	368
Future Volume (vph)	27	171	55	47	154	64	43	395	84	75	368
Satd. Flow (prot)	0	1616	0	1658	1588	0	1658	1643	0	1658	1722
Flt P/Permitted	0.936			0.487			0.465				0.389
Satd. Flow (perm)	0	1507	0	791	1588	0	782	1643	0	635	1722
Lane Group Flow (vph)	0	281	0	52	242	0	48	532	0	83	433
Turn Type	Perm	NA	Perm	NA	Perm	NA	Perm	NA	Perm	NA	Perm
Protected Phases	4	4	8	8	8	8	2	2	2	6	6
Permitted Phases	4	4	8	8	8	8	2	2	2	6	6
Detector Phase	4	4	8	8	8	8	2	2	2	6	6
Switch Phase	4	4	8	8	8	8	2	2	2	6	6
Minimum Initial (s)	10.0	10.0	10.0	10.0	10.0	10.0	10.0	10.0	10.0	10.0	10.0
Minimum Split (s)	24.5	24.5	24.5	24.5	24.5	23.7	23.7	23.7	23.7	23.7	23.7
Total Split (s)	25.0	25.0	25.0	25.0	25.0	45.0	45.0	45.0	45.0	45.0	45.0
Total Spill (%)	35.7%	35.7%	35.7%	35.7%	35.7%	64.3%	64.3%	64.3%	64.3%	64.3%	64.3%
Yellow Time (s)	3.0	3.0	3.0	3.0	3.0	3.3	3.3	3.3	3.3	3.3	3.3
All-Red Time (s)	3.5	3.5	3.5	3.5	3.5	2.4	2.4	2.4	2.4	2.4	2.4
Lost Time Adjust (s)	0.0	0.0	0.0	0.0	0.0	0.0	0.0	0.0	0.0	0.0	0.0
Total Lost Time (s)	6.5	6.5	6.5	6.5	6.5	5.7	5.7	5.7	5.7	5.7	5.7
Lead-Lag Optimize?											
Recall Mode	None	None	None	None	None	None	None	None	None	None	None
Act Effct Green (s)	17.3	17.3	17.3	17.3	17.3	17.3	17.3	17.3	17.3	17.3	17.3
Actuated G/C Ratio	0.25	0.25	0.25	0.25	0.25	0.58	0.58	0.58	0.58	0.58	0.58
v/c Ratio	0.76	0.76	0.76	0.76	0.76	0.11	0.11	0.11	0.11	0.11	0.11
Control Delay	37.8	37.8	37.8	37.8	37.8	23.8	23.8	23.8	23.8	23.8	23.8
Queue Delay	0.0	0.0	0.0	0.0	0.0	0.0	0.0	0.0	0.0	0.0	0.0
Total Delay	37.8	37.8	37.8	37.8	37.8	23.8	23.8	23.8	23.8	23.8	23.8
LOS	D	D	D	D	D	C	C	C	C	C	C
Approach Delay	37.8	37.8	37.8	37.8	37.8	25.5	25.5	25.5	25.5	25.5	25.5
Approach LOS	D	D	D	D	D	C	C	C	C	C	C
Queue Length 50th (m)	33.3	33.3	33.3	33.3	33.3	5.4	23.8	2.7	38.4	5.0	30.0
Queue Length 95th (m)	#57.3	#57.3	#57.3	#57.3	#57.3	13.6	43.1	7.6	68.1	12.8	52.0
Internal Link Dist (m)	300.5	300.5	300.5	300.5	300.5	149.8	149.8	149.8	149.8	149.8	149.8
Turn Bay Length (m)	37.5	37.5	37.5	37.5	37.5	24.0	24.0	24.0	24.0	24.0	24.0
Base Capacity (vph)	414	414	414	414	414	217	457	461	979	374	1015
Starvation Cap Reductn	0	0	0	0	0	0	0	0	0	0	0
Spillback Cap Reductn	0	0	0	0	0	0	0	0	0	0	0
Storage Cap Reductn	0	0	0	0	0	0	0	0	0	0	0
Reduced v/c Ratio	0.68	0.68	0.68	0.68	0.68	0.24	0.53	0.10	0.54	0.22	0.43
Intersection Summary											
Cycle Length: 70											
Actuated Cycle Length: 70											
Offset: 37 (53%), Referenced to phase 2:NBTL and 6:SBTL, Start of Green											
Natural Cycle: 60											
Control Type: Actuated-Coordinated											

Lanes, Volumes, Timings  
 2: Preston & Gladstone

951 Gladstone & 145 Loretta  
 Existing - AM Peak Hour

Maximum v/c Ratio: 0.76  
 Intersection Signal Delay: 18.3  
 Intersection LOS: B  
 Intersection Capacity Utilization 86.4%  
 ICU Level of Service E  
 Analysis Period (min) 15  
 # 95th percentile volume exceeds capacity, queue may be longer.  
 Queue shown is maximum after two cycles.



HCM 2010 TWSC  
 3: Breezehill & Somerset

951 Gladstone & 145 Loretta  
 Existing - AM Peak Hour

Intersection	1									
Int Delay, s/veh										
Movement	EBT	EBR	WBL	WBT	NBL	NBR				
Lane Configurations	Tb 4 W									
Traffic Vol, veh/h	260	25	14	254	16	22				
Future Vol, veh/h	260	25	14	254	16	22				
Conflicting Peds, #/hr	0	50	50	0	0	0				
Sign Control	Free	Free	Free	Free	Stop	Stop				
RT Channelized	-	None	-	None	-	None				
Storage Length	-	-	-	-	-	0				
Veh in Median Storage, #	0	-	-	0	0	0				
Grade, %	0	-	-	0	0	0				
Peak Hour Factor	90	90	90	90	90	90				
Heavy Vehicles, %	2	2	2	2	2	2				
Mvmt Flow	289	28	16	282	18	24				
Major/Minor	Major1	Major2	Minor1							
Conflicting Flow All	0	0	367	0	667	353				
Stage 1	-	-	-	-	353	-				
Stage 2	-	-	-	-	314	-				
Critical Hdwy	-	-	4.12	-	6.42	6.22				
Critical Hdwy Stg 1	-	-	-	-	5.42	-				
Critical Hdwy Stg 2	-	-	-	-	5.42	-				
Follow-up Hdwy	-	2.218	-	3.518	3.318	-				
Pl Cap-1 Maneuver	-	-	1192	-	424	691				
Stage 1	-	-	-	-	711	-				
Stage 2	-	-	-	-	741	-				
Platoon blocked, %	-	-	-	-	-	-				
Mov Cap-1 Maneuver	-	-	1146	-	401	664				
Mov Cap-2 Maneuver	-	-	-	-	401	-				
Stage 1	-	-	-	-	683	-				
Stage 2	-	-	-	-	728	-				
Approach	EB	WB	NB							
HCM Control Delay, s	0	0.4	12.5							
HCM LOS	B									
Minor Lane/Major Mvmt	NBLn1	EBT	EBR	WBL	WBT					
Capacity (veh/h)	520	-	-	1146	-					
HCM Lane V/C Ratio	0.081	-	-	0.014	-					
HCM Control Delay (s)	12.5	-	-	8.2	0					
HCM Lane LOS	B	-	-	A	A					
HCM 95th %tile Q(veh)	0.3	-	-	0	-					

HCM 2010 TWSC  
6: Loretta & Gladstone

951 Gladstone & 145 Loretta  
Existing - AM Peak Hour

Intersection	1.8											
Init Delay, s/veh	1.8											
Movement	EBL	EBT	EBR	WBL	WBT	WBR	NBL	NBT	NBR	SBL	SBT	SBR
Lane Configurations	21	209	15	19	154	33	8	0	7	21	3	9
Traffic Vol, veh/h	21	209	15	19	154	33	8	0	7	21	3	9
Future Vol, veh/h	15	0	13	13	0	15	3	0	2	2	0	3
Conflicting Peds, #/hr	Free	Free	Free	Free	Free	Free	Free	Free	Free	Free	Free	Free
Sign Control	-	-	-	-	-	-	-	-	-	-	-	-
RT Channelized	-	-	-	-	-	-	-	-	-	-	-	-
Storage Length	-	-	-	-	-	-	-	-	-	-	-	-
Veh in Median Storage, #	-	-	-	-	-	-	-	-	-	-	-	-
Grade, %	-	-	-	-	-	-	-	-	-	-	-	-
Peak Hour Factor	90	90	90	90	90	90	90	90	90	90	90	90
Heavy Vehicles, %	2	2	2	2	2	2	2	2	2	2	2	2
Mvmt Flow	23	232	17	21	171	37	9	0	8	23	3	10
Major/Minor	Major1	Major2	Major1	Major2	Major1	Major2	Minor1	Minor2	Minor1	Minor2	Minor1	Minor2
Conflicting Flow All	223	0	0	262	0	0	541	565	256	540	555	208
Stage 1	-	-	-	-	-	-	300	300	-	247	247	-
Stage 2	-	-	-	-	-	-	241	265	-	293	308	-
Critical Hdwy	4.12	-	-	4.12	-	-	7.12	6.52	6.22	7.12	6.52	6.22
Critical Hdwy Stg 1	-	-	-	-	-	-	6.12	5.52	-	6.12	5.52	-
Critical Hdwy Stg 2	-	-	-	-	-	-	6.12	5.52	-	6.12	5.52	-
Follow-up Hdwy	2.218	-	-	2.218	-	-	3.518	4.018	3.318	3.518	4.018	3.318
Pol Cap-1 Maneuver	1346	-	-	1302	-	-	452	434	783	453	440	832
Stage 1	-	-	-	-	-	-	709	666	-	757	702	-
Stage 2	-	-	-	-	-	-	762	689	-	715	660	-
Platoon blocked, %	-	-	-	-	-	-	-	-	-	-	-	-
Mov Cap-1 Maneuver	1330	-	-	1289	-	-	425	408	774	429	414	820
Mov Cap-2 Maneuver	-	-	-	-	-	-	425	408	-	429	414	-
Stage 1	-	-	-	-	-	-	688	646	-	734	680	-
Stage 2	-	-	-	-	-	-	733	668	-	693	640	-
Approach	EB	WB	NB	WB	NB	SB						
HCM Control Delay, s	0.7	0.7	11.9	11.9	12.9	12.9						
HCM LOS	B						B					
Minor Lane/Major Mvmt	NBLn1	EBL	EBT	EBR	WBL	WBR	NBLn1	NBLn2	EBLn1	EBLn2	WBLn1	WBLn2
Capacity (veh/h)	538	1330	-	-	1289	-	-	-	-	491	-	-
HCM Lane V/C Ratio	0.031	0.018	-	-	0.016	-	-	-	-	0.075	-	-
HCM Control Delay (s)	11.9	7.8	0	-	7.8	0	-	-	-	12.9	-	-
HCM Lane LOS	B	A	A	A	A	A	A	A	A	B	A	A
HCM 95th %ile Q(veh)	0.1	0.1	-	-	0.1	-	-	-	-	0.2	-	-

HCM 2010 AWSC  
7: Breezehill & Laurel

951 Gladstone & 145 Loretta  
Existing - AM Peak Hour

Intersection	7.5											
Intersection LOS	A											
Movement	EBL	EBT	EBR	WBL	WBT	WBR	NBL	NBT	NBR	SBL	SBT	SBR
Lane Configurations	11	26	10	6	8	6	11	49	10	22	31	16
Traffic Vol, veh/h	11	26	10	6	8	6	11	49	10	22	31	16
Future Vol, veh/h	0.90	0.90	0.90	0.90	0.90	0.90	0.90	0.90	0.90	0.90	0.90	0.90
Peak Hour Factor	0.90	0.90	0.90	0.90	0.90	0.90	0.90	0.90	0.90	0.90	0.90	0.90
Heavy Vehicles, %	2	2	2	2	2	2	2	2	2	2	2	2
Mvmt Flow	12	29	11	7	9	7	12	54	11	24	34	18
Number of Lanes	0	1	0	0	1	0	0	1	0	0	1	0
Approach	EB	WB	EB	WB	NB	NB	SB	SB	SB	NB	NB	SB
Opposing Approach	WB	EB	WB	EB	SB	EB	SB	SB	SB	NB	NB	SB
Opposing Lanes	1	1	1	1	1	1	1	1	1	1	1	1
Conflicting Approach Left	SB	SB	NB	NB	EB	EB	WB	WB	WB	WB	WB	WB
Conflicting Lanes Left	1	1	1	1	1	1	1	1	1	1	1	1
Conflicting Approach Right	NB	SB	SB	SB	WB	WB	EB	EB	EB	EB	EB	EB
Conflicting Lanes Right	1	1	1	1	1	1	1	1	1	1	1	1
HCM Control Delay	7.5	7.3	7.3	7.3	7.5	7.5	7.5	7.5	7.5	7.5	7.5	7.5
HCM LOS	A	A	A	A	A	A	A	A	A	A	A	A
Lane	NBLn1	EBLn1	WBLn1	WBLn1	SBLn1	SBLn1						
Vol Left, %	16%	23%	30%	30%	32%	32%						
Vol Thru, %	70%	55%	40%	45%	45%	45%						
Vol Right, %	14%	21%	30%	30%	23%	23%						
Sign Control	Stop	Stop	Stop	Stop	Stop	Stop						
Traffic Vol by Lane	70	47	20	69	69	69						
LT Vol	11	11	6	22	22	22						
Through Vol	49	26	8	31	31	31						
RT Vol	10	10	6	16	16	16						
Lane Flow Rate	78	52	22	77	77	77						
Geometry Grp	1	1	1	1	1	1						
Degree of Uln (X)	0.088	0.06	0.025	0.086	0.086	0.086						
Departure Headway (Ht)	4.067	4.136	4.12	4.047	4.047	4.047						
Convergence, Y/N	Yes	Yes	Yes	Yes	Yes	Yes						
Cap	875	855	857	879	879	879						
Service Time	2.12	2.212	2.204	2.101	2.101	2.101						
HCM Lane V/C Ratio	0.089	0.061	0.026	0.088	0.088	0.088						
HCM Control Delay	7.5	7.5	7.3	7.5	7.5	7.5						
HCM Lane LOS	A	A	A	A	A	A						
HCM 95th %ile Q	0.3	0.2	0.1	0.3	0.3	0.3						

Lanes, Volumes, Timings  
8: Bayswater & Gladstone

951 Gladstone & 145 Loretta  
Existing - AM Peak Hour

Lane Group	EBL	EBT	EBR	WBL	WBT	WBR	NBL	NBT	NBR	SBL	SBT	SBR
Lane Configurations	23	174	16	14	105	35	19	106	22	50	124	37
Traffic Volume (vph)	23	174	16	14	105	35	19	106	22	50	124	37
Future Volume (vph)	0	1706	0	0	1657	0	0	1688	0	0	1673	0
Satd. Flow (prot)	0.960			0.966			0.946				0.894	
Flt Permitted	9			32			16				20	
Satd. Flow (RTOR)	0	237	0	0	172	0	0	163	0	0	235	0
Lane Group Flow (vph)	Perm	NA	Perm	NA	Perm	NA	Perm	NA	Perm	NA	Perm	NA
Turn Types	2	2	2	6	6	6	8	8	8	4	4	4
Permitted Phases	2	2	2	6	6	6	8	8	8	4	4	4
Detector Phase	2	2	2	6	6	6	8	8	8	4	4	4
Switch Phase	10.0	10.0	10.0	10.0	10.0	10.0	10.0	10.0	10.0	10.0	10.0	10.0
Minimum Initial (s)	22.5	22.5	22.5	22.5	22.5	22.5	22.5	22.5	22.5	22.5	22.5	22.5
Minimum Split (s)	33.0	33.0	33.0	33.0	33.0	33.0	33.0	33.0	33.0	33.0	33.0	33.0
Total Split (%)	55.0%	55.0%	55.0%	55.0%	55.0%	55.0%	45.0%	45.0%	45.0%	45.0%	45.0%	45.0%
Total Split (s)	3.0	3.0	3.0	3.0	3.0	3.0	3.3	3.3	3.3	3.3	3.3	3.3
Yellow Time (s)	2.5	2.5	2.5	2.5	2.5	2.5	2.0	2.0	2.0	2.0	2.0	2.0
All-Red Time (s)	0.0	0.0	0.0	0.0	0.0	0.0	0.0	0.0	0.0	0.0	0.0	0.0
Lost Time Adjust (s)	5.5	5.5	5.5	5.5	5.5	5.5	5.3	5.3	5.3	5.3	5.3	5.3
Total Lost Time (s)												
Lead/Lag Optimize?												
Recall Mode	C-Max	C-Max	C-Max	C-Max	C-Max	C-Max	Max	Max	Max	Max	Max	Max
Act Effct Green (s)	27.5	27.5	27.5	27.5	27.5	27.5	21.7	21.7	21.7	21.7	21.7	21.7
Actuated g/C Ratio	0.46	0.46	0.46	0.46	0.46	0.46	0.36	0.36	0.36	0.36	0.36	0.36
v/c Ratio	0.31	0.23	0.23	0.23	0.23	0.23	0.28	0.42	0.42	0.42	0.42	0.42
Control Delay	11.3	8.9	8.9	13.8	13.8	13.8	16.0	16.0	16.0	16.0	16.0	16.0
Queue Delay	0.0	0.0	0.0	0.0	0.0	0.0	0.0	0.0	0.0	0.0	0.0	0.0
Total Delay	11.3	8.9	8.9	13.8	13.8	13.8	16.0	16.0	16.0	16.0	16.0	16.0
LOS	B	A	A	B	B	B	B	B	B	B	B	B
Approach Delay	11.3	8.9	8.9	13.8	13.8	13.8	16.0	16.0	16.0	16.0	16.0	16.0
Approach LOS	B	A	A	B	B	B	B	B	B	B	B	B
Queue Length 50th (m)	14.8	8.6	8.6	11.1	11.1	11.1	17.1	17.1	17.1	17.1	17.1	17.1
Queue Length 95th (m)	27.8	18.4	18.4	22.9	22.9	22.9	33.3	33.3	33.3	33.3	33.3	33.3
Internal Link Dist (m)	95.1	81.5	81.5	119.0	119.0	119.0	98.4	98.4	98.4	98.4	98.4	98.4
Turn Bay Length (m)												
Base Capacity (vph)	757	753	753	591	591	591	558	558	558	558	558	558
Starvation Cap Reductn	0	0	0	0	0	0	0	0	0	0	0	0
Spillback Cap Reductn	0	0	0	0	0	0	0	0	0	0	0	0
Storage Cap Reductn	0	0	0	0	0	0	0	0	0	0	0	0
Reduced v/c Ratio	0.31	0.23	0.23	0.28	0.28	0.28	0.42	0.42	0.42	0.42	0.42	0.42

Intersection Summary

Cycle Length: 60
Actuated Cycle Length: 60
Offset: 29 (48%), Referenced to phase 2:EBTL and 6:WBTL, Start of Green
Natural Cycle: 45
Control Type: Actuated-Coordinated

Lanes, Volumes, Timings  
8: Bayswater & Gladstone

951 Gladstone & 145 Loretta  
Existing - AM Peak Hour

Maximum v/c Ratio: 0.42
Intersection Signal Delay: 12.7
Intersection Capacity Utilization: 46.5%
Analysis Period (min): 15
Intersection LOS: B
ICU Level of Service: A

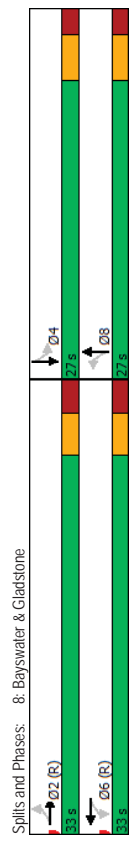

951 Gladstone & 145 Loretta  
Existing - PM Peak Hour

951 Gladstone & 145 Loretta  
Existing - PM Peak Hour

951 Gladstone & 145 Loretta  
Existing - PM Peak Hour

951 Gladstone & 145 Loretta  
Existing - PM Peak Hour

951 Gladstone & 145 Loretta  
Existing - PM Peak Hour

Intersection	1.5											
Initial Delay, s/veh	1.5											
Initial Delay, s/veh	1.5											
Movement	EBL	EBT	EBR	WBL	WBT	WBR	NBL	NBT	NBR	SBL	SBT	SBR
Lane Configurations	17	189	4	6	591	27	3	0	1	28	0	23
Traffic Vol, veh/h	17	189	4	6	591	27	3	0	1	28	0	23
Future Vol, veh/h	22	0	25	25	0	22	7	0	10	10	0	7
Conflicting Peds, #/hr	Free	Free	Free	Free	Free	Free	Free	Free	Free	Free	Free	Free
Sign Control	-	-	-	-	-	-	-	-	-	-	-	-
RT Channelized	-	-	-	-	-	-	-	-	-	-	-	-
Storage Length	-	-	-	-	-	-	-	-	-	-	-	-
Veh in Median Storage, #	-	-	-	-	-	-	-	-	-	-	-	-
Grade, %	-	-	-	-	-	-	-	-	-	-	-	-
Peak Hour Factor	90	90	90	90	90	90	90	90	90	90	90	90
Heavy Vehicles, %	2	2	2	2	2	2	2	2	2	2	2	2
Mgmt Flow	19	210	4	7	657	30	3	0	1	31	0	26
Major/Minor	Major1	Major2	Minor1	Minor2	Minor1	Minor2	Minor1	Minor2	Minor1	Minor2	Minor1	Minor2
Conflicting Flow All	709	0	0	239	0	0	981	998	247	969	985	701
Stage 1	-	-	-	-	-	-	-	275	275	-	708	708
Stage 2	-	-	-	-	-	-	-	706	723	-	261	277
Critical Hwy	4.12	-	-	4.12	-	-	7.12	6.52	6.22	7.12	6.52	6.22
Critical Hwy Slg 1	-	-	-	-	-	-	-	6.12	5.52	-	6.12	5.52
Critical Hwy Slg 2	-	-	-	-	-	-	-	6.12	5.52	-	6.12	5.52
Follow-up Hwy	2.218	-	-	2.218	-	-	3.518	4.018	3.318	3.518	4.018	3.318
Pl Cap-1 Maneuver	890	-	-	1328	-	-	229	244	792	233	248	439
Stage 1	-	-	-	-	-	-	-	731	683	-	426	438
Stage 2	-	-	-	-	-	-	-	427	431	-	744	681
Platoon blocked, %	-	-	-	-	-	-	-	-	-	-	-	-
Mov Cap-1 Maneuver	875	-	-	1302	-	-	205	227	771	221	231	429
Mov Cap-2 Maneuver	-	-	-	-	-	-	-	205	227	-	221	231
Stage 1	-	-	-	-	-	-	-	699	653	-	408	427
Stage 2	-	-	-	-	-	-	-	396	420	-	719	651
Approach	EB	WB	NB	SB	EB	WB	NB	SB	EB	WB	NB	SB
HCM Control Delay, s	0.7	0.1	19.6	20.9	0.1	19.6	20.9	0.1	19.6	20.9	0.1	19.6
HCM LOS	C	C	C	C	C	C	C	C	C	C	C	C
Minor Lane/Major Mgmt	NBLn1	EBL	EBT	EBR	WBL	WBT	WBR	NBLn1	NBT	NBR	SBL	SBT
Capacity (veh/h)	251	875	-	-	1302	-	-	283	-	-	-	-
HCM Lane V/C Ratio	0.018	0.022	-	-	0.005	-	-	0.2	-	-	-	-
HCM Control Delay (s)	19.6	9.2	0	-	7.8	0	-	20.9	-	-	-	-
HCM Lane LOS	C	A	A	A	A	A	A	C	A	A	A	A
HCM 95th %ile Q(veh)	0.1	0.1	-	-	0	-	-	0.7	-	-	-	-

Lane Group	EBL	EBT	EBR	WBL	WBT	WBR	NBL	NBT	NBR	SBL	SBT	SBR
Lane Configurations	20	183	37	80	482	77	83	374	101	52	364	54
Traffic Volume (vph)	20	183	37	80	482	77	83	374	101	52	364	54
Future Volume (vph)	0	1663	0	1658	1671	0	1658	1633	0	1658	1661	0
Satd. Flow (prot)	0.778	0.595	0.355	0.355	0.355	0.355	0.355	0.355	0.355	0.355	0.355	0.355
FI/PI Permitted	0	1299	0	968	1671	0	568	1633	0	483	1661	0
Satd. Flow (perm)	0	266	0	89	622	0	92	528	0	58	464	0
Lane Group Flow (vph)	Perm	NA	Perm	NA	Perm	NA	Perm	NA	Perm	NA	Perm	NA
Turn Type	4	4	4	8	8	8	2	2	2	6	6	6
Protected Phases	4	4	4	8	8	8	2	2	2	6	6	6
Permitted Phases	4	4	4	8	8	8	2	2	2	6	6	6
Detector Phase	4	4	4	8	8	8	2	2	2	6	6	6
Switch Phase	4	4	4	8	8	8	2	2	2	6	6	6
Minimum Initial (s)	10.0	10.0	10.0	10.0	10.0	10.0	10.0	10.0	10.0	10.0	10.0	10.0
Minimum Split (s)	24.5	24.5	24.5	24.5	24.5	24.5	23.7	23.7	23.7	23.7	23.7	23.7
Total Split (s)	33.0	33.0	33.0	33.0	33.0	33.0	37.0	37.0	37.0	37.0	37.0	37.0
Total Spill (%)	47.1%	47.1%	47.1%	47.1%	47.1%	47.1%	52.9%	52.9%	52.9%	52.9%	52.9%	52.9%
Yellow Time (s)	3.0	3.0	3.0	3.0	3.0	3.0	3.3	3.3	3.3	3.3	3.3	3.3
All-Red Time (s)	3.5	3.5	3.5	3.5	3.5	3.5	2.4	2.4	2.4	2.4	2.4	2.4
Lost Time Adjust (s)	0.0	0.0	0.0	0.0	0.0	0.0	0.0	0.0	0.0	0.0	0.0	0.0
Total Lost Time (s)	6.5	6.5	6.5	6.5	6.5	6.5	5.7	5.7	5.7	5.7	5.7	5.7
Lead-Lag Optimize?	None	None	None	None	None	None	C	C	C	C	C	C
Recall Mode	None	None	None	None	None	None	C	C	C	C	C	C
Act Effct Green (s)	28.4	28.4	28.4	28.4	28.4	28.4	29.4	29.4	29.4	29.4	29.4	29.4
Actuated G/C Ratio	0.41	0.41	0.41	0.41	0.41	0.41	0.42	0.42	0.42	0.42	0.42	0.42
v/c Ratio	0.50	0.50	0.50	0.50	0.50	0.50	0.39	0.39	0.39	0.39	0.39	0.39
Control Delay	20.0	20.0	20.0	20.0	20.0	20.0	19.7	19.7	19.7	19.7	19.7	19.7
Queue Delay	0.0	0.0	0.0	0.0	0.0	0.0	0.0	0.0	0.0	0.0	0.0	0.0
Total Delay	20.0	20.0	20.0	20.0	20.0	20.0	19.7	19.7	19.7	19.7	19.7	19.7
LOS	C	C	C	B	D	B	C	C	C	B	C	C
Approach Delay	20.0	20.0	20.0	37.2	37.2	37.2	23.7	23.7	23.7	21.4	21.4	21.4
Approach LOS	C	C	C	D	D	D	C	C	C	C	C	C
Queue Length 50th (m)	23.7	23.7	23.7	7.0	68.6	7.0	8.5	57.0	8.5	5.1	49.8	49.8
Queue Length 95th (m)	47.8	47.8	47.8	17.5	#140.8	17.5	19.0	85.2	19.0	12.7	73.0	73.0
Internal Link Dist (m)	300.5	300.5	300.5	149.8	149.8	149.8	122.5	122.5	122.5	139.6	139.6	139.6
Turn Bay Length (m)	37.5	37.5	37.5	37.5	37.5	37.5	24.0	24.0	24.0	28.0	28.0	28.0
Base Capacity (vph)	527	527	527	392	686	392	253	744	253	215	742	742
Starvation Cap Reductn	0	0	0	0	0	0	0	0	0	0	0	0
Spillback Cap Reductn	0	0	0	0	0	0	0	0	0	0	0	0
Storage Cap Reductn	0	0	0	0	0	0	0	0	0	0	0	0
Reduced v/c Ratio	0.50	0.50	0.50	0.23	0.91	0.23	0.36	0.71	0.36	0.27	0.63	0.63
Intersection Summary												
Cycle Length: 70												
Actuated Cycle Length: 70												
Offset: 40 (57%), Referenced to phase 2:NBTL and 6:SBTL, Start of Green												
Natural Cycle: 65												
Control Type: Actuated-Coordinated												

Lanes, Volumes, Timings  
 2: Preston & Gladstone

951 Gladstone & 145 Loretta  
 Existing - PM Peak Hour

Maximum v/c Ratio: 0.91  
 Intersection Signal Delay: 27.2  
 Intersection LOS: C  
 Intersection Capacity Utilization 83.9%  
 ICU Level of Service E  
 Analysis Period (min) 15  
 # 95th percentile volume exceeds capacity, queue may be longer.  
 Queue shown is maximum after two cycles.



HCM 2010 TWSC  
 3: Breezehill & Somerset

951 Gladstone & 145 Loretta  
 Existing - PM Peak Hour

Intersection	1																																																																																																																																																																						
In/Out Delay, s/veh																																																																																																																																																																							
Movement	EBT	EBR	WBL	WBT	NBL	NBR																																																																																																																																																																	
Lane Configurations	<table border="0"> <tr> <td>EBT</td><td>EBR</td><td>WBL</td><td>WBT</td><td>NBL</td><td>NBR</td> <td></td><td></td><td></td><td></td><td></td><td></td> </tr> <tr> <td>316</td><td>23</td><td>19</td><td>418</td><td>19</td><td>15</td> <td></td><td></td><td></td><td></td><td></td><td></td> </tr> <tr> <td>Traffic Vol. veh/h</td> <td>316</td><td>23</td><td>19</td><td>418</td><td>19</td><td>15</td> <td></td><td></td><td></td><td></td><td></td> </tr> <tr> <td>Future Vol. veh/h</td> <td>316</td><td>23</td><td>19</td><td>418</td><td>19</td><td>15</td> <td></td><td></td><td></td><td></td><td></td> </tr> <tr> <td>Conflicting Peds. #/hr</td> <td>0</td><td>100</td><td>100</td><td>0</td><td>19</td><td>0</td> <td></td><td></td><td></td><td></td><td></td> </tr> <tr> <td>Sign Control</td> <td>Free</td><td>Free</td><td>Free</td><td>Free</td><td>Stop</td><td>Stop</td> <td></td><td></td><td></td><td></td><td></td> </tr> <tr> <td>RT Channelized</td> <td>-</td><td>None</td><td>-</td><td>None</td><td>-</td><td>None</td> <td></td><td></td><td></td><td></td><td></td> </tr> <tr> <td>Storage Length</td> <td>-</td><td>-</td><td>-</td><td>-</td><td>-</td><td>0</td> <td></td><td></td><td></td><td></td><td></td> </tr> <tr> <td>Veh in Median Storage, #</td> <td>0</td><td>-</td><td>-</td><td>0</td><td>0</td><td>-</td> <td></td><td></td><td></td><td></td><td></td> </tr> <tr> <td>Grade, %</td> <td>0</td><td>-</td><td>-</td><td>0</td><td>0</td><td>-</td> <td></td><td></td><td></td><td></td><td></td> </tr> <tr> <td>Peak Hour Factor</td> <td>90</td><td>90</td><td>90</td><td>90</td><td>90</td><td>90</td> <td></td><td></td><td></td><td></td><td></td> </tr> <tr> <td>Heavy Vehicles, %</td> <td>2</td><td>2</td><td>2</td><td>2</td><td>2</td><td>2</td> <td></td><td></td><td></td><td></td><td></td> </tr> <tr> <td>Mvmt Flow</td> <td>351</td><td>26</td><td>21</td><td>464</td><td>21</td><td>17</td> <td></td><td></td><td></td><td></td><td></td> </tr> </table>											EBT	EBR	WBL	WBT	NBL	NBR							316	23	19	418	19	15							Traffic Vol. veh/h	316	23	19	418	19	15						Future Vol. veh/h	316	23	19	418	19	15						Conflicting Peds. #/hr	0	100	100	0	19	0						Sign Control	Free	Free	Free	Free	Stop	Stop						RT Channelized	-	None	-	None	-	None						Storage Length	-	-	-	-	-	0						Veh in Median Storage, #	0	-	-	0	0	-						Grade, %	0	-	-	0	0	-						Peak Hour Factor	90	90	90	90	90	90						Heavy Vehicles, %	2	2	2	2	2	2						Mvmt Flow	351	26	21	464	21	17					
EBT	EBR	WBL	WBT	NBL	NBR																																																																																																																																																																		
316	23	19	418	19	15																																																																																																																																																																		
Traffic Vol. veh/h	316	23	19	418	19	15																																																																																																																																																																	
Future Vol. veh/h	316	23	19	418	19	15																																																																																																																																																																	
Conflicting Peds. #/hr	0	100	100	0	19	0																																																																																																																																																																	
Sign Control	Free	Free	Free	Free	Stop	Stop																																																																																																																																																																	
RT Channelized	-	None	-	None	-	None																																																																																																																																																																	
Storage Length	-	-	-	-	-	0																																																																																																																																																																	
Veh in Median Storage, #	0	-	-	0	0	-																																																																																																																																																																	
Grade, %	0	-	-	0	0	-																																																																																																																																																																	
Peak Hour Factor	90	90	90	90	90	90																																																																																																																																																																	
Heavy Vehicles, %	2	2	2	2	2	2																																																																																																																																																																	
Mvmt Flow	351	26	21	464	21	17																																																																																																																																																																	
Major/Minor	Major1	Major2	Minor1																																																																																																																																																																				
Conflicting Flow All	0	0	477	0	989	464																																																																																																																																																																	
Stage 1	-	-	-	-	464	-																																																																																																																																																																	
Stage 2	-	-	-	-	525	-																																																																																																																																																																	
Critical Hdwy	-	-	4.12	-	6.42	6.22																																																																																																																																																																	
Critical Hdwy Stg 1	-	-	-	-	5.42	-																																																																																																																																																																	
Critical Hdwy Stg 2	-	-	-	-	5.42	-																																																																																																																																																																	
Follow-up Hdwy	-	2.218	-	3.518	3.318	-																																																																																																																																																																	
Pol Cap-1 Maneuver	-	-	1085	-	274	598																																																																																																																																																																	
Stage 1	-	-	-	-	633	-																																																																																																																																																																	
Stage 2	-	-	-	-	593	-																																																																																																																																																																	
Platoon blocked, %	-	-	-	-	-	-																																																																																																																																																																	
Mov Cap-1 Maneuver	-	-	1001	-	242	552																																																																																																																																																																	
Mov Cap-2 Maneuver	-	-	-	-	242	-																																																																																																																																																																	
Stage 1	-	-	-	-	584	-																																																																																																																																																																	
Stage 2	-	-	-	-	568	-																																																																																																																																																																	
Approach	EB	WB	NB																																																																																																																																																																				
HCM Control Delay, s	0	0.4	17.7																																																																																																																																																																				
HCM LOS	C																																																																																																																																																																						
Minor Lane/Major Mvmt	NBLn1	EBT	EBR	WBL	WBT																																																																																																																																																																		
Capacity (veh/h)	322	-	-	1001	-																																																																																																																																																																		
HCM Lane V/C Ratio	0.117	-	-	0.021	-																																																																																																																																																																		
HCM Control Delay (s)	17.7	-	-	8.7	0																																																																																																																																																																		
HCM Lane LOS	C	-	-	A	A																																																																																																																																																																		
HCM 95th %tile Q(veh)	0.4	-	-	0.1	-																																																																																																																																																																		

HCM 2010 TWSC  
6: Loretta & Gladstone

951 Gladstone & 145 Loretta  
Existing - PM Peak Hour

Intersection	1.5											
Int'l Delay, s/veh	7.4											
Intersection LOS	A											
Movement	EBL	EBT	EBR	WBL	WBT	WBR	NBL	NBT	NBR	SBL	SBT	SBR
Lane Configurations	9	205	4	9	593	31	15	0	6	20	2	16
Traffic Vol, veh/h	9	205	4	9	593	31	15	0	6	20	2	16
Future Vol, veh/h	23	0	34	0	23	0	23	0	3	3	0	2
Conflicting Peds, #/hr	Free	Free	Free	Free	Free	Free	Free	Free	Free	Free	Free	Free
Sign Control	-	-	-	-	-	-	-	-	-	-	-	-
RT Channelized	-	-	-	-	-	-	-	-	-	-	-	-
Storage Length	-	-	-	-	-	-	-	-	-	-	-	-
Veh in Median Storage, #	-	-	-	-	-	-	-	-	-	-	-	-
Grade, %	-	-	-	-	-	-	-	-	-	-	-	-
Peak Hour Factor	90	90	90	90	90	90	90	90	90	90	90	90
Heavy Vehicles, %	2	2	2	2	2	2	2	2	2	2	2	2
Mvmt Flow	10	228	4	10	659	34	17	0	7	22	2	18
Major/Minor	Major1	Major2	Major1	Major2	Major1	Major2	Minor1	Minor2	Minor1	Minor2	Minor1	Minor2
Conflicting Flow All	716	0	0	266	0	0	992	1020	267	976	1005	701
Stage 1	-	-	-	-	-	-	-	-	-	-	-	-
Stage 2	-	-	-	-	-	-	-	-	-	-	-	-
Critical Hdwy	412	-	-	412	-	-	712	652	622	712	652	622
Critical Hdwy Stg 1	-	-	-	-	-	-	612	552	-	612	552	-
Critical Hdwy Stg 2	-	-	-	-	-	-	612	552	-	612	552	-
Follow-up Hdwy	2,218	-	-	2,218	-	-	3,518	4,018	3,318	3,518	4,018	3,318
Pol Cap-1 Maneuver	885	-	-	1,298	-	-	225	237	772	230	241	439
Stage 1	-	-	-	-	-	-	723	676	-	420	433	-
Stage 2	-	-	-	-	-	-	426	425	-	748	675	-
Platoon blocked, %	-	-	-	-	-	-	-	-	-	-	-	-
Mov Cap-1 Maneuver	869	-	-	1,264	-	-	204	221	750	219	225	430
Mov Cap-2 Maneuver	-	-	-	-	-	-	204	221	-	219	225	-
Stage 1	-	-	-	-	-	-	695	650	-	407	420	-
Stage 2	-	-	-	-	-	-	400	412	-	730	649	-
Approach	EB	WB	WB	EB	WB	WB	NB	NB	SB	SB	SB	SB
HCM Control Delay, s	0.4	0.1	0.1	20.3	20.3	20.3	20.3	20.3	20.3	20.3	20.3	20.3
HCM LOS	C	C	C	C	C	C	C	C	C	C	C	C
Minor Lane/Major Mvmt	NBLn1	EBL	EBT	EBR	WBL	WBT	WBR	SBLn1	SBT	SBR	SBLn1	SBT
Capacity (veh/h)	258	869	-	-	1264	-	-	-	-	277	-	-
HCM Lane V/C Ratio	0.09	0.012	-	-	0.008	-	-	-	-	0.152	-	-
HCM Control Delay (s)	20.3	9.2	0	-	7.9	0	-	-	-	20.3	-	-
HCM Lane LOS	C	A	A	A	A	A	A	A	A	A	A	A
HCM 95th %ile Q(veh)	0.3	0	-	-	0	-	-	-	-	0.5	-	-

HCM 2010 AWSC  
7: Breezehill & Laurel

951 Gladstone & 145 Loretta  
Existing - PM Peak Hour

Intersection	7.4											
Intersection LOS	A											
Movement	EBL	EBT	EBR	WBL	WBT	WBR	NBL	NBT	NBR	SBL	SBT	SBR
Lane Configurations	12	8	10	4	22	6	24	22	1	3	45	32
Traffic Vol, veh/h	12	8	10	4	22	6	24	22	1	3	45	32
Future Vol, veh/h	0.90	0.90	0.90	0.90	0.90	0.90	0.90	0.90	0.90	0.90	0.90	0.90
Peak Hour Factor	2	2	2	2	2	2	2	2	2	2	2	2
Heavy Vehicles, %	13	9	11	4	24	7	27	24	1	3	50	36
Mvmt Flow	0	1	0	0	1	0	0	1	0	1	0	1
Approach	EB	WB	WB	EB	WB	WB	NB	NB	SB	SB	SB	SB
Opposing Approach	WB	EB	EB	WB	WB	WB	SB	SB	SB	NB	NB	NB
Opposing Lanes	1	1	1	1	1	1	1	1	1	1	1	1
Conflicting Approach Left	SB	SB	NB	NB	EB	EB	EB	WB	WB	WB	WB	WB
Conflicting Lanes Left	1	1	1	1	1	1	1	1	1	1	1	1
Conflicting Approach Right	NB	SB	SB	WB	WB	WB	EB	EB	EB	EB	EB	EB
Conflicting Lanes Right	1	1	1	1	1	1	1	1	1	1	1	1
HCM Control Delay	7.3	7.4	7.4	7.4	7.4	7.4	7.5	7.3	7.3	7.3	7.3	7.3
HCM LOS	A	A	A	A	A	A	A	A	A	A	A	A
Lane	NBLn1	EBLn1	WBLn1	WBLn1	SBLn1	SBLn1	NBLn1	NBLn1	SBLn1	SBLn1	SBLn1	SBLn1
Vol Left, %	51%	40%	12%	4%	4%	4%	4%	4%	4%	4%	4%	4%
Vol Thru, %	47%	27%	69%	56%	56%	56%	56%	56%	56%	56%	56%	56%
Vol Right, %	2%	33%	19%	40%	40%	40%	40%	40%	40%	40%	40%	40%
Sign Control	Stop	Stop	Stop	Stop	Stop	Stop	Stop	Stop	Stop	Stop	Stop	Stop
Traffic Vol by Lane	47	30	32	80	80	80	80	80	80	80	80	80
LT Vol	24	12	4	3	3	3	3	3	3	3	3	3
Through Vol	22	8	22	45	45	45	45	45	45	45	45	45
RT Vol	1	10	6	32	32	32	32	32	32	32	32	32
Lane Flow Rate	52	33	36	89	89	89	89	89	89	89	89	89
Geometry Grp	1	1	1	1	1	1	1	1	1	1	1	1
Degree of Uln (X)	0.061	0.038	0.041	0.095	0.095	0.095	0.095	0.095	0.095	0.095	0.095	0.095
Departure Headway (Ht)	4.212	4.085	4.116	3.862	3.862	3.862	3.862	3.862	3.862	3.862	3.862	3.862
Convergence, Y/N	Yes	Yes	Yes	Yes	Yes	Yes	Yes	Yes	Yes	Yes	Yes	Yes
Cap	846	867	861	923	923	923	923	923	923	923	923	923
Service Time	2.26	2.153	2.183	1.908	1.908	1.908	1.908	1.908	1.908	1.908	1.908	1.908
HCM Lane V/C Ratio	0.061	0.038	0.042	0.096	0.096	0.096	0.096	0.096	0.096	0.096	0.096	0.096
HCM Control Delay	7.5	7.3	7.4	7.3	7.3	7.3	7.3	7.3	7.3	7.3	7.3	7.3
HCM Lane LOS	A	A	A	A	A	A	A	A	A	A	A	A
HCM 95th %ile Q	0.2	0.1	0.1	0.1	0.1	0.1	0.1	0.1	0.1	0.1	0.1	0.1

Lanes, Volumes, Timings  
8: Bayswater & Gladstone

951 Gladstone & 145 Loretta  
Existing - PM Peak Hour

Lane Group	EBL	EBT	EBR	WBL	WBT	WBR	NBL	NBT	NBR	SBL	SBT	SBR
Lane Configurations	10	147	18	74	429	114	29	182	28	35	206	34
Traffic Volume (vph)	10	147	18	74	429	114	29	182	28	35	206	34
Future Volume (vph)	0	1701	0	0	1661	0	0	1698	0	0	1694	0
Satd. Flow (prot)	0.960			0.937			0.938				0.934	
Flt Permitted												
Satd. Flow (perm)	0	1636	0	0	1558	0	0	1600	0	0	1589	0
Satd. Flow (RTOR)	14			28			12				12	
Lane Group Flow (vph)	0	194	0	0	686	0	0	265	0	0	306	0
Turn Types	Perm	NA	Perm	NA	Perm	NA	Perm	NA	Perm	NA	Perm	NA
Protected Phases	2	2	6	6	6	6	8	8	8	4	4	4
Permitted Phases	2	2	6	6	6	6	8	8	8	4	4	4
Detector Phase												
Switch Phase												
Minimum Initial (s)	10.0	10.0	10.0	10.0	10.0	10.0	10.0	10.0	10.0	10.0	10.0	10.0
Minimum Split (s)	22.5	22.5	22.5	22.5	22.5	22.5	22.5	22.5	22.5	22.5	22.5	22.5
Total Split (s)	36.0	36.0	36.0	36.0	36.0	36.0	36.0	36.0	36.0	36.0	36.0	36.0
Total Split (%)	60.0%	60.0%	60.0%	60.0%	60.0%	60.0%	60.0%	60.0%	60.0%	60.0%	60.0%	60.0%
Yellow Time (s)	3.0	3.0	3.0	3.0	3.0	3.0	3.3	3.3	3.3	3.3	3.3	3.3
All-Red Time (s)	2.5	2.5	2.5	2.5	2.5	2.5	2.0	2.0	2.0	2.0	2.0	2.0
Lost Time Adjust (s)	0.0	0.0	0.0	0.0	0.0	0.0	0.0	0.0	0.0	0.0	0.0	0.0
Total Lost Time (s)	5.5	5.5	5.5	5.5	5.5	5.5	5.3	5.3	5.3	5.3	5.3	5.3
Lead/Lag Optimize?												
Recall Mode	C-Max	C-Max	C-Max	C-Max	C-Max	C-Max	Max	Max	Max	Max	Max	Max
Act Effct Green (s)	30.5	30.5	30.5	30.5	30.5	30.5	18.7	18.7	18.7	18.7	18.7	18.7
Actuated g/C Ratio	0.51	0.51	0.51	0.51	0.51	0.51	0.31	0.31	0.31	0.31	0.31	0.31
v/c Ratio	0.23	0.23	0.23	0.85	0.85	0.85	0.52	0.52	0.61	0.61	0.61	0.61
Control Delay	8.5	8.5	8.5	25.5	25.5	25.5	20.7	20.7	23.0	23.0	23.0	23.0
Queue Delay	0.0	0.0	0.0	0.0	0.0	0.0	0.0	0.0	0.0	0.0	0.0	0.0
Total Delay	8.5	8.5	8.5	25.5	25.5	25.5	20.7	20.7	23.0	23.0	23.0	23.0
LOS	A	A	A	C	C	C	C	C	C	C	C	C
Approach Delay	8.5	8.5	8.5	25.5	25.5	25.5	20.7	20.7	23.0	23.0	23.0	23.0
Approach LOS	A	A	A	C	C	C	C	C	C	C	C	C
Queue Length 50th (m)	10.1	10.1	10.1	57.9	57.9	57.9	22.4	22.4	27.0	27.0	27.0	27.0
Queue Length 95th (m)	19.8	19.8	19.8	#121.1	#121.1	#121.1	41.7	41.7	49.3	49.3	49.3	49.3
Internal Link Dist (m)	95.1	95.1	95.1	81.5	81.5	81.5	119.0	119.0	98.4	98.4	98.4	98.4
Turn Bay Length (m)												
Base Capacity (vph)	838	838	838	805	805	805	506	506	503	503	503	503
Starvation Cap Reductn	0	0	0	0	0	0	0	0	0	0	0	0
Spillback Cap Reductn	0	0	0	0	0	0	0	0	0	0	0	0
Storage Cap Reductn	0	0	0	0	0	0	0	0	0	0	0	0
Reduced v/c Ratio	0.23	0.23	0.23	0.85	0.85	0.85	0.52	0.52	0.61	0.61	0.61	0.61

Intersection Summary

Cycle Length: 60
Actuated Cycle Length: 60
Offset: 63 (88%), Referenced to phase 2:EBTL and 6:WBTL, Start of Green
Natural Cycle: 60
Control Type: Actuated-Coordinated

Lanes, Volumes, Timings  
8: Bayswater & Gladstone

951 Gladstone & 145 Loretta  
Existing - PM Peak Hour

Maximum v/c Ratio: 0.85	Intersection LOS: C
Intersection Signal Delay: 21.8	ICU Level of Service: E
Intersection Capacity Utilization: 84.1%	
Analysis Period (min): 15	
# 95th percentile volume exceeds capacity, queue may be longer.	
Queue shown is maximum after two cycles.	

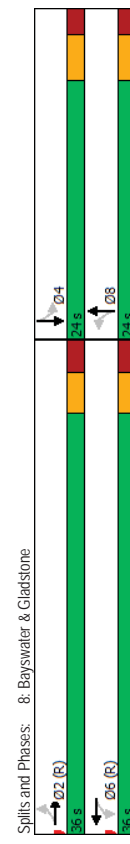

# Appendix D

Collision Data

Accident ID	Accident Date	Accident Location	Accident Description	Classification of Accident	Initial Impact Type	Environment	Control	Light	Non-Surface Control	Traffic Control	Traffic Control Control	No. of Vehicles	No. of Bicycles	No. of Motorcycles	No. of Pedestrians	Max Injury	No. of Fatal	No. of Major	No. of Minor	No. of Property Damage	Uninsured	Uninsured	Object	
16-1048	2018-09-02	@ GLADSTONE AVE @ GLADSTONE AVE (0006164)	03 - Non-fatal injury	03 - Rear end	02 - Rain	01 - Daylight	02 - Wet	01 - Traffic signal	01 - Functioning	01 - Functioning	01 - Functioning	2	0	0	0	0	0	0	1	3600015	5029479	45.40256	-75.718230	236
16-1153	2018-11-12	6:01 PM BAYSWATER AVE @ GLADSTONE AVE (0006164)	03 - P.D. only	03 - Rear end	01 - Clear	01 - Daylight	01 - Dry	01 - Traffic signal	01 - Functioning	01 - Functioning	01 - Functioning	2	0	0	0	0	0	0	0	3600014	5029481	45.40259	-75.718205	1764
16-6478	2016-06-14	5:42 PM BAYSWATER AVE @ GLADSTONE AVE (0006164)	03 - P.D. only	03 - Rear end	01 - Clear	01 - Daylight	01 - Dry	01 - Traffic signal	01 - Functioning	01 - Functioning	01 - Functioning	2	0	0	0	0	0	0	0	3600018	5029479	45.40276	-75.7182245	10683
17-10664	2017-10-14	12:20 PM BAYSWATER AVE @ GLADSTONE AVE (0006164)	03 - P.D. only	05 - Turning movement	01 - Clear	01 - Daylight	02 - Wet	01 - Traffic signal	01 - Functioning	01 - Functioning	01 - Functioning	2	0	0	0	0	0	0	0	3600017	5029478	45.40256	-75.7182189	271
17-12510	2017-11-28	7:06 PM BAYSWATER AVE @ GLADSTONE AVE (0006164)	03 - Non-fatal injury	03 - Rear end	01 - Clear	01 - Daylight	01 - Dry	01 - Traffic signal	01 - Functioning	01 - Functioning	01 - Functioning	3	0	0	0	0	0	0	0	3600017	5029480	45.40284	-75.7182179	2606
17-1798	2017-02-12	1:39 PM BAYSWATER AVE @ GLADSTONE AVE (0006164)	03 - P.D. only	02 - Angle	03 - Snow	01 - Daylight	03 - Loose snow	01 - Traffic signal	01 - Functioning	01 - Functioning	01 - Functioning	2	0	0	0	0	0	0	0	3600022	5029479	45.40275	-75.7182117	5525
17-8459	2017-08-22	2:29 PM BAYSWATER AVE @ GLADSTONE AVE (0006164)	03 - P.D. only	05 - Turning movement	01 - Clear	01 - Daylight	01 - Dry	01 - Traffic signal	01 - Functioning	01 - Functioning	01 - Functioning	2	0	0	0	0	0	0	0	3600023	5029480	45.40278	-75.7182302	2461
18-5291	2018-05-16	6:10 PM BAYSWATER AVE @ GLADSTONE AVE (0006164)	03 - P.D. only	03 - Rear end	01 - Clear	01 - Daylight	01 - Dry	01 - Traffic signal	01 - Functioning	01 - Functioning	01 - Functioning	2	0	0	0	0	0	0	0	3600007	5029480	45.40278	-75.7182308	9109
19-12278	2019-10-10	8:47 AM BAYSWATER AVE @ GLADSTONE AVE (0006164)	03 - P.D. only	05 - Turning movement	01 - Clear	01 - Daylight	01 - Dry	01 - Traffic signal	01 - Functioning	01 - Functioning	01 - Functioning	2	0	0	0	0	0	0	0	3600007	5029480	45.40258	-75.7182312	2433
19-12867	2019-10-24	4:42 PM BAYSWATER AVE @ GLADSTONE AVE (0006164)	03 - Non-fatal injury	07 - SWV other	01 - Clear	01 - Daylight	01 - Dry	01 - Traffic signal	01 - Functioning	01 - Functioning	01 - Functioning	1	0	0	0	0	0	0	0	3600005	5029479	45.40279	-75.7182323	3863
19-2759	2019-02-14	7:58 PM BAYSWATER AVE @ GLADSTONE AVE (0006164)	03 - Non-fatal injury	07 - SWV other	01 - Clear	01 - Daylight	02 - Packed snow	01 - Traffic signal	01 - Functioning	01 - Functioning	01 - Functioning	1	0	0	0	0	0	0	0	3600006	5029480	45.40279	-75.7182322	8818
19-938	2019-01-18	9:50 AM BAYSWATER AVE @ GLADSTONE AVE (0006164)	02 - Angle	02 - Angle	03 - Snow	01 - Daylight	03 - Loose snow	01 - Traffic signal	01 - Functioning	01 - Functioning	01 - Functioning	2	0	0	0	0	0	0	0	3600007	5029480	45.40278	-75.7182304	15137
20-332	2020-01-09	1:06 PM BAYSWATER AVE @ GLADSTONE AVE (0006164)	03 - P.D. only	02 - Angle	01 - Clear	01 - Daylight	01 - Dry	01 - Traffic signal	01 - Functioning	01 - Functioning	01 - Functioning	2	0	0	0	0	0	0	0	3600006	5029480	45.40278	-75.7182321	2044
20-8328	2020-11-03	1:17 PM BAYSWATER AVE @ GLADSTONE AVE (0006164)	03 - Non-fatal injury	01 - Clear	01 - Clear	01 - Daylight	01 - Dry	01 - Traffic signal	01 - Functioning	01 - Functioning	01 - Functioning	2	0	0	0	0	0	0	0	3600007	5029480	45.40278	-75.7182309	8791
16-10156	2016-09-29	Unknown BREZEZHILL AVE @ N BOWN SOMERSET ST W & LAUREL ST ( _3A24A)	03 - P.D. only	06 - SMV unattended veh	01 - Clear	00 - Unknown	00 - Unknown	00 - Unknown	00 - Unknown	00 - Unknown	00 - Unknown	1	0	0	0	0	0	0	0	3600021	5029740	45.40401	-75.7183008	887
16-12776	2016-12-07	3:25 PM BREZEZHILL AVE @ GLADSTONE AVE (0006286)	03 - Non-fatal injury	05 - Turning movement	01 - Clear	01 - Daylight	02 - Wet	02 - Stop sign	01 - Functioning	01 - Functioning	01 - Functioning	2	0	0	0	0	0	0	0	3600987	5029524	45.40266	-75.7169704	3922
18-4887	2018-06-28	4:27 PM BREZEZHILL AVE @ GLADSTONE AVE (0006286)	03 - P.D. only	02 - Angle	01 - Clear	01 - Daylight	01 - Dry	02 - Stop sign	01 - Functioning	01 - Functioning	01 - Functioning	2	0	0	0	0	0	0	0	3600986	5029524	45.40266	-75.7169739	11793
19-7449	2019-06-14	11:13 PM BREZEZHILL AVE @ GLADSTONE AVE (0006286)	03 - P.D. only	02 - Angle	01 - Clear	01 - Daylight	01 - Dry	02 - Stop sign	01 - Functioning	01 - Functioning	01 - Functioning	2	0	0	0	0	0	0	0	3600986	5029524	45.40266	-75.7169749	13624
18-6984	2018-06-15	10:18 PM GLADSTONE AVE @ LORETTA AVE (0006092)	03 - Non-fatal injury	07 - SWV other	01 - Clear	01 - Daylight	01 - Dry	02 - Stop sign	01 - Functioning	01 - Functioning	01 - Functioning	1	0	0	0	0	0	0	0	3600987	5029586	45.40433	-75.7157280	10938
16-1852	2016-02-12	5:40 PM GLADSTONE AVE @ PRESTON ST (0002212)	03 - P.D. only	03 - Rear end	03 - Snow	05 - Dusk	03 - Loose snow	01 - Traffic signal	01 - Functioning	01 - Functioning	01 - Functioning	2	0	0	0	0	0	0	0	3604885	5029713	45.40434	-75.7159586	4507
16-3967	2016-04-01	6:23 AM GLADSTONE AVE @ PRESTON ST (0002212)	02 - Non-fatal injury	03 - Rear end	01 - Clear	01 - Daylight	01 - Dry	03 - Down	02 - Wet	01 - Traffic signal	01 - Functioning	1	0	0	0	0	0	0	0	3604881	5029712	45.40431	-75.7159633	7133
16-7075	2016-06-29	9:45 AM GLADSTONE AVE @ PRESTON ST (0002212)	03 - P.D. only	07 - SWV other	01 - Clear	01 - Daylight	01 - Dry	01 - Traffic signal	01 - Functioning	01 - Functioning	01 - Functioning	1	0	0	0	0	0	0	0	3604882	5029713	45.40434	-75.7159699	10192
16-7984	2016-07-26	3:25 PM GLADSTONE AVE @ PRESTON ST (0002212)	03 - Non-fatal injury	07 - SWV other	01 - Clear	01 - Daylight	01 - Dry	01 - Traffic signal	01 - Functioning	01 - Functioning	01 - Functioning	1	0	0	0	0	0	0	0	3604885	5029713	45.40436	-75.7159587	11863
16-8456	2016-08-10	9:45 AM GLADSTONE AVE @ PRESTON ST (0002212)	03 - Rear end	01 - Clear	01 - Clear	01 - Daylight	01 - Dry	01 - Traffic signal	01 - Functioning	01 - Functioning	01 - Functioning	1	0	0	0	0	0	0	0	3604885	5029713	45.40432	-75.7159687	12352
16-8418	2016-08-09	6:15 PM GLADSTONE AVE @ PRESTON ST (0002212)	03 - Non-fatal injury	05 - Turning movement	01 - Clear	01 - Daylight	01 - Dry	01 - Traffic signal	01 - Functioning	01 - Functioning	01 - Functioning	2	0	0	0	0	0	0	0	3604885	5029713	45.40432	-75.7159687	12612
17-10763	2017-10-22	2:18 PM GLADSTONE AVE @ PRESTON ST (0002212)	03 - P.D. only	02 - Angle	01 - Clear	01 - Daylight	01 - Dry	01 - Traffic signal	00 - Unknown	00 - Unknown	00 - Unknown	2	0	0	0	0	0	0	0	3604887	5029712	45.40463	-75.7159559	606
17-14172	2017-12-27	9:15 AM GLADSTONE AVE @ PRESTON ST (0002212)	03 - P.D. only	05 - Turning movement	03 - Snow	01 - Daylight	06 - Ice	01 - Traffic signal	01 - Functioning	01 - Functioning	01 - Functioning	2	0	0	0	0	0	0	0	3604889	5029713	45.40434	-75.7159528	4504
18-11703	2018-11-05	5:14 PM GLADSTONE AVE @ PRESTON ST (0002212)	03 - Non-fatal injury	07 - SWV other	02 - Rain	01 - Daylight	02 - Wet	01 - Traffic signal	01 - Functioning	01 - Functioning	01 - Functioning	1	0	0	0	0	0	0	0	3604887	5029713	45.40432	-75.7159558	1310
18-3956	2018-08-04	2:25 PM GLADSTONE AVE @ PRESTON ST (0002212)	03 - Non-fatal injury	07 - SWV other	01 - Clear	01 - Daylight	01 - Dry	01 - Traffic signal	01 - Functioning	01 - Functioning	01 - Functioning	1	0	0	0	0	0	0	0	3604884	5029712	45.40436	-75.7159604	7922
18-596	2018-01-10	2:17 PM GLADSTONE AVE @ PRESTON ST (0002212)	03 - Rear end	01 - Clear	01 - Clear	01 - Daylight	04 - Slush	01 - Traffic signal	01 - Functioning	01 - Functioning	01 - Functioning	2	0	0	0	0	0	0	0	3604887	5029713	45.40432	-75.7159558	10256
18-6961	2018-06-29	7:26 AM GLADSTONE AVE @ PRESTON ST (0002212)	03 - Non-fatal injury	05 - Turning movement	01 - Clear	01 - Daylight	01 - Dry	01 - Traffic signal	01 - Functioning	01 - Functioning	01 - Functioning	2	0	0	0	0	0	0	0	3604887	5029713	45.40432	-75.7159668	11461
19-11148	2019-10-31	2:18 PM GLADSTONE AVE @ PRESTON ST (0002212)	03 - P.D. only	02 - Angle	01 - Clear	01 - Daylight	01 - Dry	01 - Traffic signal	01 - Functioning	01 - Functioning	01 - Functioning	1	0	0	0	0	0	0	0	3604887	5029713	45.40432	-75.7159558	3397
19-1517	2019-01-25	8:27 AM GLADSTONE AVE @ PRESTON ST (0002212)	03 - Rear end	01 - Clear	01 - Clear	01 - Daylight	04 - Slush	01 - Traffic signal	01 - Functioning	01 - Functioning	01 - Functioning	2	0	0	0	0	0	0	0	3604887	5029713	45.40431	-75.7159665	5615
19-1541	2019-01-26	5:14 PM GLADSTONE AVE @ PRESTON ST (0002212)	03 - P.D. only	03 - Rear end	01 - Clear	01 - Snow	05 - Dusk	06 - Ice	01 - Traffic signal	00 - Unknown	00 - Unknown	2	0	0	0	0	0	0	0	3604886	5029713	45.40432	-75.7159649	6290
19-7022	2019-06-03	9:08 AM GLADSTONE AVE @ PRESTON ST (0002212)	03 - P.D. only	04 - Sidewipe	01 - Clear	01 - Daylight	01 - Dry	01 - Traffic signal	01 - Functioning	01 - Functioning	01 - Functioning	2	0	0	0	0	0	0	0	3604888	5029712	45.40461	-75.7159548	13830
20-16	2020-01-01	6:00 PM GLADSTONE AVE @ PRESTON ST (0002212)	03 - P.D. only	02 - Angle	01 - Clear	01 - Daylight	02 - Wet	01 - Traffic signal	01 - Functioning	01 - Functioning	01 - Functioning	2	0	0	0	0	0	0	0	3604887	5029713	45.40432	-75.7159558	424
20-3408	2020-03-06	7:31 AM GLADSTONE AVE @ PRESTON ST (0002212)	03 - Non-fatal injury	03 - Rear end	01 - Clear	01 - Daylight	04 - Slush	01 - Traffic signal	01 - Functioning	01 - Functioning	01 - Functioning	2	0	0	0	0	0	0	0	3604887	5029713	45.40432	-75.7159558	2843
20-5581	2020-07-15	9:01 PM GLADSTONE AVE @ PRESTON ST (0002212)	03 - Non-fatal injury	05 - Turning movement	01 - Clear	01 - Daylight	01 - Dry	01 - Traffic signal	01 - Functioning	01 - Functioning	01 - Functioning	2	1	0	0	0	0	0	0	3604887	5029713	45.40432	-75.7159558	5753
19-9701	2019-08-10	4:41 PM GLADSTONE AVE @ BOWN BAYSWATER AVE & BREZEZHILL AVE N ( _3A239)	03 - P.D. only	99 - Other	01 - Clear	01 - Daylight	01 - Dry	00 - No control	00 - No control	00 - No control	00 - No control	2	0	0	0	0	0	0	0	3606885	5029519	45.40226	-75.7171049	16207
20-5307	2020-07-03	3:15 PM GLADSTONE AVE @ BOWN BAYSWATER AVE & BREZEZHILL AVE N ( _3A239)	03 - P.D. only	03 - Rear end	01 - Clear	01 - Daylight	01 - Dry	00 - No control	00 - No control	00 - No control	00 - No control	2	0	0	0	0	0	0	0	360074	5029513	45.40269	-75.7172899	4474
20-2726	2020-02-22	10:21 AM GLADSTONE AVE @ BOWN BREEZEZHILL AVE N & LORETTA AVE ( _3A239)	03 - P.D. only	99 - Other	01 - Clear	01 - Daylight	01 - Dry	00 - No control	00 - No control	00 - No control	00 - No control	2	0	0	0	0	0	0	0	3601888	5029566	45.03318	-75.7180854	1704
18-12366	2018-11-17	6:30 PM GLADSTONE AVE @ BOWN LORETTA AVE N & PRESTON ST ( _3A231H)	03 - P.D. only	04 - Sidewipe	01 - Clear	01 - Daylight	02 - Wet	00 - No control	00 - No control	00 - No control	00 - No control	2	0	0	0	0	0	0	0	366413	5029680	45.40447	-75.7129392	4751
18-2157	2																							

# Appendix E

MMLOS Analysis

### Multi-Modal Level of Service - Intersections Form

Consultant  
Scenario  
Comments

CGH Transportation Inc
Existing and Future

Project  
Date

2020-25
12/20/2021

INTERSECTIONS		Gladstone @ Bayswater				Gladstone @ Preston			
Crossing Side		NORTH	SOUTH	EAST	WEST	NORTH	SOUTH	EAST	WEST
Pedestrian	Lanes	4	3	3	3	4	4	5	0 - 2
	Median	No Median - 2.4 m	No Median - 2.4 m	No Median - 2.4 m	No Median - 2.4 m	No Median - 2.4 m	No Median - 2.4 m	No Median - 2.4 m	No Median - 2.4 m
	Conflicting Left Turns	Permissive	Permissive	Permissive	Permissive	Permissive	Permissive	Permissive	Permissive
	Conflicting Right Turns	Permissive or yield control	Permissive or yield control	Permissive or yield control	Permissive or yield control	Permissive or yield control	Permissive or yield control	Permissive or yield control	Permissive or yield control
	Right Turns on Red (RTor) ?	RTOR allowed	RTOR allowed	RTOR allowed	RTOR allowed	RTOR allowed	RTOR prohibited	RTOR prohibited	RTOR allowed
	Ped Signal Leading Interval?	No	No	No	No	no	no	no	No
	Right Turn Channel	No Channel	No Channel	No Channel	No Channel	No Channel	No Channel	No Channel	No Channel
	Corner Radius	5-10m	5-10m	5-10m	5-10m	5-10m	5-10m	10-15m	5-10m
	Crosswalk Type	Std transverse markings	Std transverse markings	Zebra stripe hi-vis markings	Zebra stripe hi-vis markings	Textured/coloured pavement	Textured/coloured pavement	Textured/coloured pavement	Textured/coloured pavement
	<b>PETSI Score</b>	<b>54</b>	<b>71</b>	<b>74</b>	<b>74</b>	<b>57</b>	<b>60</b>	<b>43</b>	<b>89</b>
	<b>Ped. Exposure to Traffic LoS</b>	<b>D</b>	<b>C</b>	<b>C</b>	<b>C</b>	<b>D</b>	<b>C</b>	<b>E</b>	<b>B</b>
	Cycle Length	60	60	60	60	70	70	70	70
	Effective Walk Time	22	22	11	11	28	28	11	11
	<b>Average Pedestrian Delay</b>	<b>12</b>	<b>12</b>	<b>20</b>	<b>20</b>	<b>13</b>	<b>13</b>	<b>25</b>	<b>25</b>
<b>Pedestrian Delay LoS</b>	<b>B</b>	<b>B</b>	<b>C</b>	<b>C</b>	<b>B</b>	<b>B</b>	<b>C</b>	<b>C</b>	
<b>Level of Service</b>	<b>D</b>	<b>C</b>	<b>C</b>	<b>C</b>	<b>D</b>	<b>C</b>	<b>E</b>	<b>C</b>	
		<b>D</b>				<b>E</b>			
Approach From		NORTH	SOUTH	EAST	WEST	NORTH	SOUTH	EAST	WEST
Bicycle	Bicycle Lane Arrangement on Approach	Mixed Traffic	Mixed Traffic	Mixed Traffic	Mixed Traffic	Mixed Traffic	Mixed Traffic	Mixed Traffic	Mixed Traffic
	Right Turn Lane Configuration								
	Right Turning Speed								
	<b>Cyclist relative to RT motorists</b>	<b>#N/A</b>	<b>#N/A</b>	<b>#N/A</b>	<b>#N/A</b>	<b>#N/A</b>	<b>#N/A</b>	<b>#N/A</b>	<b>#N/A</b>
	<b>Separated or Mixed Traffic</b>	<b>Mixed Traffic</b>	<b>Mixed Traffic</b>	<b>Mixed Traffic</b>	<b>Mixed Traffic</b>	<b>Mixed Traffic</b>	<b>Mixed Traffic</b>	<b>Mixed Traffic</b>	<b>Mixed Traffic</b>
	Left Turn Approach	No lane crossed	No lane crossed	No lane crossed	No lane crossed	One lane crossed	One lane crossed	One lane crossed	No lane crossed
	Operating Speed	≤ 40 km/h	≤ 40 km/h	> 40 to ≤ 50 km/h	> 40 to ≤ 50 km/h	> 40 to ≤ 50 km/h	> 40 to ≤ 50 km/h	> 40 to ≤ 50 km/h	> 40 to ≤ 50 km/h
<b>Left Turning Cyclist</b>	<b>B</b>	<b>B</b>	<b>B</b>	<b>B</b>	<b>D</b>	<b>D</b>	<b>D</b>	<b>B</b>	
<b>Level of Service</b>	<b>#N/A</b>	<b>#N/A</b>	<b>#N/A</b>	<b>#N/A</b>	<b>#N/A</b>	<b>#N/A</b>	<b>#N/A</b>	<b>#N/A</b>	
		<b>#N/A</b>				<b>#N/A</b>			
Transit	Average Signal Delay			≤ 30 sec	≤ 20 sec	≤ 20 sec	≤ 20 sec	≤ 40 sec	≤ 40 sec
	<b>Level of Service</b>	<b>-</b>	<b>-</b>	<b>D</b>	<b>C</b>	<b>C</b>	<b>C</b>	<b>E</b>	<b>E</b>
		<b>D</b>				<b>E</b>			
Truck	Effective Corner Radius					10 - 15 m	10 - 15 m	10 - 15 m	
	Number of Receiving Lanes on Departure from Intersection					1	1	1	
	<b>Level of Service</b>	<b>-</b>	<b>-</b>	<b>-</b>	<b>-</b>	<b>E</b>	<b>E</b>	<b>E</b>	<b>-</b>
		<b>-</b>				<b>E</b>			
Auto	Volume to Capacity Ratio		0.71 - 0.80				0.71 - 0.80		
	<b>Level of Service</b>	<b>C</b>				<b>C</b>			

# Multi-Modal Level of Service - Segments Form

Consultant  
Scenario  
Comments

<b>CGH Transportation Inc</b>
<b>Existing and Future</b>

Project  
Date

<b>2020-25</b>
<b>4/7/2021</b>

SEGMENTS			Gladstone	Loretta (frontage)	Loretta (frontage)
			1	2	3
<b>Pedestrian</b>	Sidewalk Width	<b>C</b>	≥ 2 m	no sidewalk	≥ 2 m
	Boulevard Width		< 0.5	n/a	0.5 - 2 m
	Avg Daily Curb Lane Traffic Volume		> 3000	≤ 3000	≤ 3000
	Operating Speed		> 30 to 50 km/h	> 30 to 50 km/h	> 30 to 50 km/h
	On-Street Parking		no	yes	no
	<b>Exposure to Traffic PLoS</b>		<b>C</b>	<b>F</b>	<b>A</b>
	Effective Sidewalk Width		2.0 m		
	Pedestrian Volume		500 ped /hr		
<b>Crowding PLoS</b>	<b>B</b>	-	-		
<b>Level of Service</b>	<b>C</b>	-	-		
<b>Bicycle</b>	Type of Cycling Facility	<b>D</b>	Mixed Traffic	Mixed Traffic	Mixed Traffic
	Number of Travel Lanes		2-3 lanes total	≤ 2 (no centreline)	≤ 2 (no centreline)
	Operating Speed		>40 to <50 km/h	>40 to <50 km/h	>40 to <50 km/h
	<b># of Lanes &amp; Operating Speed LoS</b>		<b>D</b>	<b>B</b>	<b>B</b>
	Bike Lane (+ Parking Lane) Width				
	<b>Bike Lane Width LoS</b>		-	-	-
	Bike Lane Blockages				
	<b>Blockage LoS</b>		-	-	-
	Median Refuge Width (no median = < 1.8 m)		< 1.8 m refuge	< 1.8 m refuge	< 1.8 m refuge
	No. of Lanes at Unsignalized Crossing		≤ 3 lanes	≤ 3 lanes	≤ 3 lanes
	Sidestreet Operating Speed		>40 to 50 km/h	≤ 40 km/h	≤ 40 km/h
<b>Unsignalized Crossing - Lowest LoS</b>	<b>B</b>	<b>A</b>	<b>A</b>		
<b>Level of Service</b>	<b>D</b>	<b>B</b>	<b>B</b>		
<b>Transit</b>	Facility Type	<b>D</b>	Mixed Traffic		
	Friction or Ratio Transit:Posted Speed		Vt/Vp ≥ 0.8		
	<b>Level of Service</b>		<b>D</b>	-	-
<b>Truck</b>	Truck Lane Width	<b>-</b>			
	Travel Lanes per Direction				
<b>Level of Service</b>	<b>-</b>	-	-		
<b>Auto</b>	<b>Level of Service</b>	<b>Not Applicable</b>			

# Appendix F

Synchro Intersection Worksheets – Future Total Conditions

951 Gladstone & 145 Loretta  
Future Total-AM Peak Hour

951 Gladstone & 145 Loretta  
Future Total-AM Peak Hour

951 Gladstone & 145 Loretta  
Future Total-AM Peak Hour

Lanes, Volumes, Timings  
2: Preston & Gladstone

Lanes, Volumes, Timings  
2: Preston & Gladstone

Intersection	1.4													
Initial Delay, s/veh														
Movement	EBL	EBT	EBR	WBL	WBT	WBR	NBL	NBT	NBR	SBL	SBT	SBR		
Lane Configurations	23	266	0	1	147	41	2	1	5	17	0	23		
Traffic Vol. veh/h	23	266	0	1	147	41	2	1	5	17	0	23		
Future Vol. veh/h	23	266	0	1	147	41	2	1	5	17	0	23		
Conflicting Peds. #/hr	25	0	25	0	25	0	25	0	25	0	25	0		
Sign Control	Free	Free	Free	Free	Free	Free	Free	Free	Free	Free	Free	Free		
RT Channelized	-	-	-	-	-	-	-	-	-	-	-	-		
Storage Length	-	-	-	-	-	-	-	-	-	-	-	-		
Veh in Median Storage, #	-	-	-	-	-	-	-	-	-	-	-	-		
Grade, %	-	-	-	-	-	-	-	-	-	-	-	-		
Peak Hour Factor	100	100	100	100	100	100	100	100	100	100	100	100		
Heavy Vehicles, %	2	2	2	2	2	2	2	2	2	2	2	2		
Mgmt Flow	23	266	0	1	147	41	2	1	5	17	0	23		
Major/Minor	Major1	Major2	Major1	Minor1	Minor2	Minor2	Minor2	Minor2	Minor2	Minor2	Minor2	Minor2		
Conflicting Flow All	213	0	0	291	0	0	526	552	293	512	532	201		
Stage 1	-	-	-	-	-	-	337	337	-	195	195	-		
Stage 2	-	-	-	-	-	-	189	215	-	317	337	-		
Critical Hwy	412	-	-	412	-	-	712	652	622	712	652	622		
Critical Hwy Stg 1	-	-	-	-	-	-	612	552	-	612	552	-		
Critical Hwy Stg 2	-	-	-	-	-	-	612	552	-	612	552	-		
Follow-up Hwy	2218	-	-	2218	-	-	3518	4018	3318	3518	4018	3318		
Pol Cap-1 Maneuver	1357	-	-	1271	-	-	462	442	746	472	453	840		
Stage 1	-	-	-	-	-	-	677	641	-	807	739	-		
Stage 2	-	-	-	-	-	-	813	725	-	694	641	-		
Platoon blocked, %	-	-	-	-	-	-	-	-	-	-	-	-		
Mov Cap-1 Maneuver	1331	-	-	1246	-	-	431	416	730	451	427	819		
Mov Cap-2 Maneuver	-	-	-	-	-	-	431	416	-	451	427	-		
Stage 1	-	-	-	-	-	-	651	616	-	716	724	-		
Stage 2	-	-	-	-	-	-	784	711	-	673	616	-		
Approach	EB	WB	NB	SB	SB	SB	SB	SB	SB	SB	SB	SB		
HCM Control Delay, s	0.6	0	11.3	11.3	11.3	11.3	11.3	11.3	11.3	11.3	11.3	11.3		
HCM LOS	B	B	B	B	B	B	B	B	B	B	B	B		
Minor Lane/Major Mvmt	NBLn1	EBL	EBT	EBR	WBL	WBT	WBR	SBLn1	SBLn1	SBLn1	SBLn1	SBLn1		
Capacity (veh/h)	576	1331	-	-	1246	-	-	608	-	-	-	-		
HCM Lane V/C Ratio	0.014	0.017	-	-	0.001	-	-	0.066	-	-	-	-		
HCM Control Delay (s)	11.3	7.8	0	-	7.9	0	-	11.3	-	-	-	-		
HCM Lane LOS	B	A	A	-	A	-	-	B	-	-	-	-		
HCM 95th %ile Q(veh)	0	0.1	-	-	0	-	-	0.2	-	-	-	-		

Lane Group	EBL	EBT	EBR	WBL	WBT	WBR	NBL	NBT	NBR	SBL	SBT	SBR
Lane Configurations	29	177	63	47	168	64	62	395	84	75	368	27
Traffic Volume (vph)	29	177	63	47	168	64	62	395	84	75	368	27
Future Volume (vph)	0	197	0	1658	1590	0	1658	1643	0	1658	1715	0
Satd. Flow (prot)	0.938	0.938	0.508	0.508	0.494	0.494	0.494	0.494	0.494	0.494	0.427	0.427
Flt P/Permitted	0	1491	0	816	1590	0	826	1643	0	690	1715	0
Satd. Flow (perm)	0	269	0	47	232	0	62	479	0	75	395	0
Lane Group Flow (vph)	Perm	NA	Perm	NA	Perm	NA	Perm	NA	Perm	NA	Perm	NA
Turn Type	4	4	4	8	8	8	2	2	2	6	6	6
Protected Phases	4	4	4	8	8	8	2	2	2	6	6	6
Permitted Phases	4	4	4	8	8	8	2	2	2	6	6	6
Detector Phase	4	4	4	8	8	8	2	2	2	6	6	6
Switch Phase	4	4	4	8	8	8	2	2	2	6	6	6
Minimum Initial (s)	10.0	10.0	10.0	10.0	10.0	10.0	10.0	10.0	10.0	10.0	10.0	10.0
Minimum Split (s)	24.5	24.5	24.5	24.5	24.5	24.5	23.7	23.7	23.7	23.7	23.7	23.7
Total Split (s)	25.0	25.0	25.0	25.0	25.0	25.0	45.0	45.0	45.0	45.0	45.0	45.0
Total Spill (%)	35.7%	35.7%	35.7%	35.7%	35.7%	35.7%	64.3%	64.3%	64.3%	64.3%	64.3%	64.3%
Yellow Time (s)	3.0	3.0	3.0	3.0	3.0	3.0	3.3	3.3	3.3	3.3	3.3	3.3
All-Red Time (s)	3.5	3.5	3.5	3.5	3.5	3.5	2.4	2.4	2.4	2.4	2.4	2.4
Lost Time Adjust (s)	0.0	0.0	0.0	0.0	0.0	0.0	0.0	0.0	0.0	0.0	0.0	0.0
Total Lost Time (s)	6.5	6.5	6.5	6.5	6.5	6.5	5.7	5.7	5.7	5.7	5.7	5.7
Lead-Lag												
Lead-Lag Optimize?												
Recall Mode	None	None	None	None	None	None	C-Min	C-Min	C-Min	C-Min	C-Min	C-Min
Act Effct Green (s)	17.6	17.6	17.6	17.6	17.6	17.6	40.2	40.2	40.2	40.2	40.2	40.2
Actuated G/C Ratio	0.25	0.25	0.25	0.25	0.25	0.25	0.57	0.57	0.57	0.57	0.57	0.57
v/c Ratio	0.72	0.72	0.72	0.23	0.55	0.13	0.13	0.50	0.19	0.19	0.40	0.40
Control Delay	36.3	36.3	36.3	21.8	24.3	9.4	11.8	10.4	10.4	10.4	10.9	10.9
Queue Delay	0.0	0.0	0.0	0.0	0.0	0.0	0.0	0.0	0.0	0.0	0.0	0.0
Total Delay	36.3	36.3	36.3	21.8	24.3	9.4	11.8	10.4	10.4	10.4	10.9	10.9
LOS	D	D	D	C	C	C	A	B	B	B	B	B
Approach Delay	36.3	36.3	36.3	23.9	23.9	11.5	11.5	10.8	10.8	10.8	10.8	10.8
Approach LOS	D	D	D	C	C	C	B	B	B	B	B	B
Queue Length 50th (m)	39.1	39.1	39.1	4.9	23.0	3.4	32.3	4.3	4.3	4.3	26.1	26.1
Queue Length 95th (m)	28.0	28.0	28.0	11.5	38.1	10.5	66.2	12.9	12.9	12.9	52.7	52.7
Internal Link Dist (m)	140.4	140.4	140.4	149.8	149.8	149.8	122.5	122.5	122.5	122.5	139.6	139.6
Turn Bay Length (m)	37.5	37.5	37.5	37.5	37.5	37.5	24.0	24.0	24.0	24.0	28.0	28.0
Base Capacity (vph)	422	422	422	231	470	490	966	966	409	1018	1018	1018
Starvation Cap Reductn	0	0	0	0	0	0	0	0	0	0	0	0
Spillback Cap Reductn	0	0	0	0	0	0	0	0	0	0	0	0
Storage Cap Reductn	0	0	0	0	0	0	0	0	0	0	0	0
Reduced v/c Ratio	0.64	0.64	0.64	0.20	0.49	0.13	0.49	0.18	0.18	0.18	0.39	0.39
Intersection Summary												
Cycle Length: 70												
Actuated Cycle Length: 70												
Offset: 37 (53%), Referenced to phase 2:NBTL and 6:SBTL, Start of Green												
Natural Cycle: 55												
Control Type: Actuated-Coordinated												

Lanes, Volumes, Timings  
2: Preston & Gladstone

HCM Signalized Intersection Capacity Analysis  
2: Preston & Gladstone

951 Gladstone & 145 Loretta  
Future Total-AM Peak Hour

Maximum v/c Ratio: 0.72  
Intersection Signal Delay: 17.8  
Intersection Capacity Utilization 88.3%  
Analysis Period (min) 15

Future Total-AM Peak Hour  
EBL EBT EBR WBL WBT WBR NBL NBT NBR SBL SBT SBR

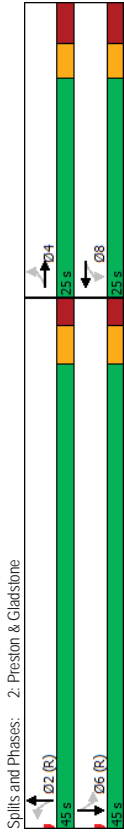

Movement	EBL	EBT	EBR	WBL	WBT	WBR	NBL	NBT	NBR	SBL	SBT	SBR
Lane Configurations												
Traffic Volume (vph)	29	177	63	47	168	64	62	395	84	75	368	27
Future Volume (vph)	29	177	63	47	168	64	62	395	84	75	368	27
Ideal Flow (vphpl)	1800	1800	1800	1800	1800	1800	1800	1800	1800	1800	1800	1800
Total Lost time (s)	6.5	6.5	6.5	6.5	6.5	6.5	5.7	5.7	5.7	5.7	5.7	5.7
Lane Util. Factor	1.00	1.00	1.00	1.00	1.00	1.00	1.00	1.00	1.00	1.00	1.00	1.00
Frpb, ped/bikes	0.95	1.00	0.95	1.00	0.95	1.00	0.97	0.97	1.00	0.99	1.00	0.99
Flpb, ped/bikes	0.99	0.92	1.00	0.96	1.00	0.96	1.00	0.97	1.00	0.93	1.00	0.99
Flt	0.97	1.00	0.96	1.00	0.96	1.00	0.95	0.95	1.00	0.95	1.00	0.99
Fill Protected	1581	1528	1588	1588	1589	1642	1534	1715	1534	1715	1534	1715
Satd. Flow (prot)	0.94	0.51	1.00	0.49	1.00	0.43	1.00	0.43	1.00	0.43	1.00	0.43
Fill Permitted	1491	817	1588	826	1642	690	1715	690	1715	690	1715	690
Satd. Flow (perm)	1.00	1.00	1.00	1.00	1.00	1.00	1.00	1.00	1.00	1.00	1.00	1.00
Peak-hour factor, PHF	29	177	63	47	168	64	62	395	84	75	368	27
Adj. Flow (vph)	0	0	0	0	20	0	0	11	0	0	0	0
RTOR Reduction (vph)	0	269	0	47	212	0	62	468	0	75	395	0
Lane Group Flow (vph)	59	65	65	59	40	87	87	87	87	87	87	40
Confl. Peds. (#/hr)	44	44	44	44	29	29	11	11	11	11	11	12
Confl. Bikes (#/hr)												
Turn Type	Perm	NA	NA	Perm	NA	NA	Perm	NA	Perm	NA	Perm	NA
Protected Phases	4			8			2				6	
Permitted Phases	4			8			2				6	
Actuated Green, G (s)	17.6			17.6			40.2				40.2	
Effective Green, g (s)	17.6			17.6			40.2				40.2	
Actuated g/C Ratio	0.25			0.25			0.57				0.57	
Clearance Time (s)	6.5			6.5			5.7				5.7	
Vehicle Extension (s)	3.0			3.0			3.0				3.0	
Lane Grp Cap (vph)	374			205			474				396	
v/s Ratio Prot	c0.18			0.13			c0.29				0.23	
v/c Ratio	0.72			0.23			0.13				0.19	
Uniform Delay, d1	23.9			20.8			6.9				7.1	
Progression Factor	1.08			1.00			1.00				1.00	
Incremental Delay, d2	6.5			0.6			0.6				1.1	
Delay (s)	32.2			21.4			7.4				8.2	
Level of Service	C			C			A				A	
Approach Delay (s)	32.2			23.6			10.4				9.3	
Approach LOS	C			C			B				A	
Intersection Summary												
HCM 2000 Control Delay	16.2 HCM 2000 Level of Service B											
HCM 2000 Volume to Capacity ratio	0.56											
Actuated Cycle Length (s)	70.0											
Intersection Capacity Utilization	88.3% ICU Level of Service E											
Analysis Period (min)	15											
c Critical Lane Group												

HCM 2010 TWSC  
3: Brezezhill & Somersset

951 Gladstone & 145 Loretta  
Future Total-AM Peak Hour

951 Gladstone & 145 Loretta  
Future Total-AM Peak Hour

Intersection																				
Int Delay, s/veh	1.1																			
Movement	EBT	EBR	WBL	WBT	NBL	NBR														
Lane Configurations	<table border="0"> <tr> <td>260</td><td>32</td><td>16</td><td>254</td><td>19</td><td>23</td> <td>4</td><td>W</td><td colspan="2"></td> </tr> </table>										260	32	16	254	19	23	4	W		
260	32	16	254	19	23	4	W													
Traffic Vol, veh/h	260	32	16	254	19	23														
Future Vol, veh/h	260	32	16	254	19	23														
Conflicting Peds, #/hr	0	50	50	0	0	0														
Sign Control	Free	Free	Free	Free	Stop	Stop														
RT Channelized	-	None	-	None	-	None														
Storage Length	-	-	-	-	-	0														
Veh in Median Storage, #	0	-	-	0	0	-														
Grade, %	0	-	-	0	0	-														
Peak Hour Factor	100	100	100	100	100	100														
Heavy Vehicles, %	2	2	2	2	2	2														
Mvmt Flow	260	32	16	254	19	23														
Major/Minor	Major1	Major2	Minor1																	
Conflicting Flow All	0	0	342	0	612	326														
Stage 1	-	-	-	326	-	-														
Stage 2	-	-	-	286	-	-														
Critical Hdwy	-	-	4.12	-	6.42	6.22														
Critical Hdwy Stg 1	-	-	-	-	5.42	-														
Critical Hdwy Stg 2	-	-	-	-	5.42	-														
Follow-up Hdwy	-	-	2.218	-	3.518	3.318														
Pot Cap-1 Maneuver	-	-	1217	-	456	715														
Stage 1	-	-	-	731	-	-														
Stage 2	-	-	-	763	-	-														
Platoon blocked, %	-	-	-	-	-	-														
Mov Cap-1 Maneuver	-	-	1170	-	431	687														
Mov Cap-2 Maneuver	-	-	-	431	-	-														
Stage 1	-	-	-	702	-	-														
Stage 2	-	-	-	751	-	-														
Approach	EB	WB	NB																	
HCM Control Delay, s	0	0.5	12.2																	
HCM LOS	B																			
Minor Lane/Major Mvmt	NBLn1	EBT	EBR	WBL	WBT															
Capacity (veh/h)	541	-	-	1170	-															
HCM Lane V/C Ratio	0.078	-	-	0.014	-															
HCM Control Delay (s)	12.2	-	-	8.1	0															
HCM Lane LOS	B	-	-	A	A															
HCM 95th %ile Q(veh)	0.3	-	-	0	-															

Intersection																				
Int Delay, s/veh	0.3																			
Movement	WBL	WBR	NBT	NBR	SBL	SBT														
Lane Configurations	<table border="0"> <tr> <td>2</td><td>2</td><td>58</td><td>0</td><td>0</td><td>47</td> <td>4</td><td>W</td><td colspan="2"></td> </tr> </table>										2	2	58	0	0	47	4	W		
2	2	58	0	0	47	4	W													
Traffic Vol, veh/h	2	2	58	0	0	47														
Future Vol, veh/h	2	2	58	0	0	47														
Conflicting Peds, #/hr	0	0	0	0	0	0														
Sign Control	Stop	Stop	Free	Free	Free	Free														
RT Channelized	-	None	-	None	-	None														
Storage Length	0	-	-	-	-	-														
Veh in Median Storage, #	0	-	0	-	-	0														
Grade, %	0	-	0	-	-	0														
Peak Hour Factor	100	100	100	100	100	100														
Heavy Vehicles, %	2	2	2	2	2	2														
Mvmt Flow	2	2	58	0	0	47														
Major/Minor	Minor1	Major1	Major2																	
Conflicting Flow All	105	58	0	-	-	-														
Stage 1	58	-	-	-	-	-														
Stage 2	47	-	-	-	-	-														
Critical Hdwy	6.42	6.22	-	-	-	-														
Critical Hdwy Stg 1	5.42	-	-	-	-	-														
Critical Hdwy Stg 2	5.42	-	-	-	-	-														
Follow-up Hdwy	3.518	3.318	-	-	-	-														
Pot Cap-1 Maneuver	893	1008	-	0	0	-														
Stage 1	965	-	0	0	-	-														
Stage 2	975	-	0	0	-	-														
Platoon blocked, %	-	-	-	-	-	-														
Mov Cap-1 Maneuver	893	1008	-	-	-	-														
Mov Cap-2 Maneuver	893	-	-	-	-	-														
Stage 1	965	-	-	-	-	-														
Stage 2	975	-	-	-	-	-														
Approach	WB	NB	SB																	
HCM Control Delay, s	8.8	0	0																	
HCM LOS	A																			
Minor Lane/Major Mvmt	NBTWBLn1	SBT																		
Capacity (veh/h)	-	947	-																	
HCM Lane V/C Ratio	-	0.004	-																	
HCM Control Delay (s)	-	8.8	-																	
HCM Lane LOS	-	A	-																	
HCM 95th %ile Q(veh)	-	0	-																	

HCM 2010 TWSC  
5: Loretta & Access #2  
951 Gladstone & 145 Loretta  
Future Total-AM Peak Hour

Intersection	2.8											
Int Delay, s/wch	2.8											
Movement	EBL	EBT	EBR	WBL	WBT	WBR	NBL	NBT	NBR	SBL	SBT	SBR
Lane Configurations	4											
Traffic Vol, veh/h	59	209	15	19	154	76	8	0	7	37	3	27
Future Vol, veh/h	59	209	15	19	154	76	8	0	7	37	3	27
Conflicting Peds, #/hr	25	0	14	14	0	25	3	0	3	3	0	3
Sign Control	Free	Free	Free	Free	Free	Free	Free	Free	Free	Free	Free	Free
RT Channelized	-	-	None	-	-	None	-	-	None	-	-	None
Storage Length	-	-	-	-	-	-	-	-	-	-	-	-
Veh in Median Storage, #	-	0	-	-	-	0	-	-	0	-	-	0
Grade, %	-	0	-	-	-	0	-	-	0	-	-	0
Peak Hour Factor	100	100	100	100	100	100	100	100	100	100	100	100
Heavy Vehicles, %	2	2	2	2	2	2	2	2	2	2	2	2
Mvmt Flow	59	209	15	19	154	76	8	0	7	37	3	27
Major/Minor	Major1	Major2	Major1	Minor1	Minor2	Major1	Minor1	Minor2	Major1	Minor1	Minor2	Major1
Conflicting Flow All	255	0	0	238	0	0	597	642	234	596	611	220
Stage 1	-	-	-	-	-	-	349	349	-	255	255	-
Stage 2	-	-	-	-	-	-	248	293	-	341	356	-
Critical Hdwy	4.12	-	-	4.12	-	-	7.12	6.52	6.22	7.12	6.52	6.22
Critical Hdwy Stg 1	-	-	-	-	-	-	6.12	5.52	-	6.12	5.52	-
Critical Hdwy Stg 2	-	-	-	-	-	-	6.12	5.52	-	6.12	5.52	-
Follow-up Hdwy	2.218	-	-	2.218	-	-	3.518	4.018	3.318	3.518	4.018	3.318
Pot Cap-1 Maneuver	1310	-	-	1329	-	-	415	392	805	415	409	820
Stage 1	-	-	-	-	-	-	667	633	-	749	696	-
Stage 2	-	-	-	-	-	-	756	670	-	674	629	-
Platoon blocked, %	-	-	-	-	-	-	-	-	-	-	-	-
Mov Cap-1 Maneuver	1285	-	-	1315	-	-	373	354	794	381	369	802
Mov Cap-2 Maneuver	-	-	-	-	-	-	373	354	-	381	369	-
Stage 1	-	-	-	-	-	-	625	593	-	696	671	-
Stage 2	-	-	-	-	-	-	713	646	-	631	589	-
Approach	EB	WB	NB	WB	NB	SB	WB	NB	SB	WB	NB	SB
HCM Control Delay, s	1.7	0.6	12.5	13.7	13.7	13.7	13.7	13.7	13.7	13.7	13.7	13.7
HCM LOS	B	B	B	B	B	B	B	B	B	B	B	B
Minor Lane/Major Mvmt	NBLn1	EBL	EBT	EBR	WBL	WBT	WBR	NBLn1	NBLn1	NBLn1	NBLn1	NBLn1
Capacity (veh/h)	496	1285	-	-	1315	-	-	482	-	-	-	-
HCM Lane V/C Ratio	0.03	0.046	-	-	0.014	-	-	0.139	-	-	-	-
HCM Control Delay (s)	12.5	7.9	0	-	7.8	0	-	13.7	-	-	-	-
HCM Lane LOS	B	A	A	A	A	A	A	B	-	-	-	-
HCM 95th %ile Q(veh)	0.1	0.1	-	-	0	-	-	0.5	-	-	-	-

HCM 2010 TWSC  
6: Loretta & Gladstone  
951 Gladstone & 145 Loretta  
Future Total-AM Peak Hour

Intersection	2.8											
Int Delay, s/wch	2.8											
Movement	EBL	EBT	EBR	WBL	WBT	WBR	NBL	NBT	NBR	SBL	SBT	SBR
Lane Configurations	4											
Traffic Vol, veh/h	59	209	15	19	154	76	8	0	7	37	3	27
Future Vol, veh/h	59	209	15	19	154	76	8	0	7	37	3	27
Conflicting Peds, #/hr	25	0	14	14	0	25	3	0	3	3	0	3
Sign Control	Free	Free	Free	Free	Free	Free	Free	Free	Free	Free	Free	Free
RT Channelized	-	-	None	-	-	None	-	-	None	-	-	None
Storage Length	-	-	-	-	-	-	-	-	-	-	-	-
Veh in Median Storage, #	-	0	-	-	-	0	-	-	0	-	-	0
Grade, %	-	0	-	-	-	0	-	-	0	-	-	0
Peak Hour Factor	100	100	100	100	100	100	100	100	100	100	100	100
Heavy Vehicles, %	2	2	2	2	2	2	2	2	2	2	2	2
Mvmt Flow	59	209	15	19	154	76	8	0	7	37	3	27
Major/Minor	Major1	Major2	Major1	Minor1	Minor2	Major1	Minor1	Minor2	Major1	Minor1	Minor2	Major1
Conflicting Flow All	255	0	0	238	0	0	597	642	234	596	611	220
Stage 1	-	-	-	-	-	-	349	349	-	255	255	-
Stage 2	-	-	-	-	-	-	248	293	-	341	356	-
Critical Hdwy	4.12	-	-	4.12	-	-	7.12	6.52	6.22	7.12	6.52	6.22
Critical Hdwy Stg 1	-	-	-	-	-	-	6.12	5.52	-	6.12	5.52	-
Critical Hdwy Stg 2	-	-	-	-	-	-	6.12	5.52	-	6.12	5.52	-
Follow-up Hdwy	2.218	-	-	2.218	-	-	3.518	4.018	3.318	3.518	4.018	3.318
Pot Cap-1 Maneuver	1310	-	-	1329	-	-	415	392	805	415	409	820
Stage 1	-	-	-	-	-	-	667	633	-	749	696	-
Stage 2	-	-	-	-	-	-	756	670	-	674	629	-
Platoon blocked, %	-	-	-	-	-	-	-	-	-	-	-	-
Mov Cap-1 Maneuver	1285	-	-	1315	-	-	373	354	794	381	369	802
Mov Cap-2 Maneuver	-	-	-	-	-	-	373	354	-	381	369	-
Stage 1	-	-	-	-	-	-	625	593	-	696	671	-
Stage 2	-	-	-	-	-	-	713	646	-	631	589	-
Approach	EB	WB	NB	WB	NB	SB	WB	NB	SB	WB	NB	SB
HCM Control Delay, s	1.7	0.6	12.5	13.7	13.7	13.7	13.7	13.7	13.7	13.7	13.7	13.7
HCM LOS	B	B	B	B	B	B	B	B	B	B	B	B
Minor Lane/Major Mvmt	NBLn1	EBL	EBT	EBR	WBL	WBT	WBR	NBLn1	NBLn1	NBLn1	NBLn1	NBLn1
Capacity (veh/h)	496	1285	-	-	1315	-	-	482	-	-	-	-
HCM Lane V/C Ratio	0.03	0.046	-	-	0.014	-	-	0.139	-	-	-	-
HCM Control Delay (s)	12.5	7.9	0	-	7.8	0	-	13.7	-	-	-	-
HCM Lane LOS	B	A	A	A	A	A	A	B	-	-	-	-
HCM 95th %ile Q(veh)	0.1	0.1	-	-	0	-	-	0.5	-	-	-	-

HCM 2010 AWSC  
7: Breezehill & Laurel

951 Gladstone & 145 Loretta  
Future Total-AM Peak Hour

Intersection	Delay, s/veh	7.5										
Intersection LOS	A											
Movement	EBL	EBT	EBR	WBL	WBT	WBR	NBL	NBT	NBR	SBL	SBT	SBR
Lane Configurations	11	31	10	6	10	10	11	49	10	32	31	16
Traffic Vol, veh/h	11	31	10	6	10	10	11	49	10	32	31	16
Future Vol, veh/h	1.00	1.00	1.00	1.00	1.00	1.00	1.00	1.00	1.00	1.00	1.00	1.00
Peak Hour Factor	2	2	2	2	2	2	2	2	2	2	2	2
Heavy Vehicles, %	11	31	10	6	10	10	11	49	10	32	31	16
Mount Flow	0	1	0	0	1	0	0	1	0	0	1	0
Number of Lanes												
Approach	EB	WB	WB	EB	WB	NB	NB	SB	SB	NB	NB	
Opposing Approach	1	1	1	1	1	1	1	1	1	1	1	
Opposing Lanes	SB	NB	WB	EB	WB	EB	WB	WB	WB	WB	WB	
Conflicting Approach Left	1	1	1	1	1	1	1	1	1	1	1	
Conflicting Lanes Left	NB	SB	WB	EB	WB	EB	WB	WB	WB	WB	WB	
Conflicting Approach Right	1	1	1	1	1	1	1	1	1	1	1	
Conflicting Lanes Right	1	1	1	1	1	1	1	1	1	1	1	
HCM Control Delay	7.5	7.3	7.3	7.3	7.5	7.5	7.5	7.5	7.5	7.5	7.5	
HCM LOS	A	A	A	A	A	A	A	A	A	A	A	

Lane	NBLnt	EBLnt1	WBLnt1	SBLnt1	SBLnt
Vol Left, %	16%	21%	23%	41%	
Vol Thru, %	70%	60%	38%	39%	
Vol Right, %	14%	19%	38%	20%	
Sign Control	Stop	Stop	Stop	Stop	
Traffic Vol by Lane	70	52	26	79	
LT Vol	11	11	6	32	
Through Vol	49	31	10	31	
RT Vol	10	10	10	16	
Lane Flow Rate	70	52	26	79	
Geometry Grp	1	1	1	1	
Degree of UHl (X)	0.079	0.06	0.029	0.09	
Departure Headway (Hd)	4.075	4.137	4.046	4.082	
Convergence, Y/N	Yes	Yes	Yes	Yes	
Cap	872	855	872	871	
Service Time	2.131	2.214	2.13	2.136	
HCM Lane V/C Ratio	0.08	0.061	0.03	0.091	
HCM Control Delay	7.5	7.5	7.3	7.5	
HCM Lane LOS	A	A	A	A	
HCM 95th-ile Q	0.3	0.2	0.1	0.3	

Lanes, Volumes, Timings  
8: Bayswater & Gladstone

951 Gladstone & 145 Loretta  
Future Total-AM Peak Hour

Lane Group	EBL	EBT	EBR	WBL	WBT	WBR	NBL	NBT	NBR	SBL	SBT	SBR
Lane Configurations	23	217	16	14	123	35	19	106	22	50	124	37
Traffic Volume (vph)	23	217	16	14	123	35	19	106	22	50	124	37
Future Volume (vph)	0	1713	0	0	1666	0	0	1687	0	0	1673	0
Satd. Flow (prot)	0.968			0.970								
Flt P/Permitted	0	1661	0	0	1620	0	0	1612	0	0	1522	0
Satd. Flow (RT OR)	7			28								
Satd. Flow (RT OR)	0	256	0	0	172	0	0	147	0	0	211	0
Lane Group Flow (vph)	Perm	NA	Perm	NA	Perm	NA	Perm	NA	Perm	NA	Perm	NA
Turn Types	2	2	2	6	6	6	8	8	8	4	4	4
Protected Phases	2	2	2	6	6	6	8	8	8	4	4	4
Permitted Phases	2	2	2	6	6	6	8	8	8	4	4	4
Detector Phase	2	2	2	6	6	6	8	8	8	4	4	4
Switch Phase												
Minimum Initial (s)	10.0	10.0	10.0	10.0	10.0	10.0	10.0	10.0	10.0	10.0	10.0	10.0
Minimum Split (s)	22.5	22.5	22.5	22.5	22.5	22.5	22.5	22.5	22.5	22.5	22.5	22.5
Total Split (s)	33.0	33.0	33.0	33.0	33.0	33.0	33.0	33.0	33.0	33.0	33.0	33.0
Total Spill (%)	55.0%	55.0%	55.0%	55.0%	55.0%	55.0%	45.0%	45.0%	45.0%	45.0%	45.0%	45.0%
Yellow Time (s)	3.0	3.0	3.0	3.0	3.0	3.0	3.3	3.3	3.3	3.3	3.3	3.3
All-Red Time (s)	2.5	2.5	2.5	2.5	2.5	2.5	2.0	2.0	2.0	2.0	2.0	2.0
Lost Time Adjust (s)	0.0	0.0	0.0	0.0	0.0	0.0	0.0	0.0	0.0	0.0	0.0	0.0
Total Lost Time (s)	5.5	5.5	5.5	5.5	5.5	5.5	5.3	5.3	5.3	5.3	5.3	5.3
Lead/Lag Optimize?												
Recall Mode	C-Max	C-Max	C-Max	C-Max	C-Max	C-Max	Max	Max	Max	Max	Max	Max
Act Effct Green (s)	27.5	27.5	27.5	27.5	27.5	27.5	21.7	21.7	21.7	21.7	21.7	21.7
Actuated g/C Ratio	0.46	0.46	0.46	0.46	0.46	0.46	0.36	0.36	0.36	0.36	0.36	0.36
v/c Ratio	0.33	0.33	0.23	0.23	0.23	0.25	0.25	0.25	0.25	0.25	0.25	0.25
Control Delay	11.7	9.1	9.1	13.2	13.2	13.2	15.1	15.1	15.1	15.1	15.1	15.1
Queue Delay	0.0	0.0	0.0	0.0	0.0	0.0	0.0	0.0	0.0	0.0	0.0	0.0
Total Delay	11.7	9.1	9.1	13.2	13.2	13.2	15.1	15.1	15.1	15.1	15.1	15.1
LOS	B	A	A	B	B	B	B	B	B	B	B	B
Approach Delay	11.7	9.1	9.1	13.2	13.2	13.2	15.1	15.1	15.1	15.1	15.1	15.1
Approach LOS	B	A	A	B	B	B	B	B	B	B	B	B
Queue Length 50th (m)	16.4	8.9	8.9	18.7	18.7	18.7	20.6	20.6	20.6	20.6	20.6	20.6
Queue Length 95th (m)	30.2	18.7	18.7	20.6	20.6	20.6	29.6	29.6	29.6	29.6	29.6	29.6
Internal Link Dist (m)	95.1	81.5	81.5	119.0	119.0	119.0	98.4	98.4	98.4	98.4	98.4	98.4
Turn Bay Length (m)												
Base Capacity (vph)	765	757	757	593	593	593	563	563	563	563	563	563
Starvation Cap Reductn	0	0	0	0	0	0	0	0	0	0	0	0
Spillback Cap Reductn	0	0	0	0	0	0	0	0	0	0	0	0
Storage Cap Reductn	0	0	0	0	0	0	0	0	0	0	0	0
Reduced v/c Ratio	0.33	0.23	0.23	0.25	0.25	0.25	0.37	0.37	0.37	0.37	0.37	0.37
Intersection Summary												
Cycle Length: 60												
Actuated Cycle Length: 60												
Offset: 29 (48%), Referenced to phase 2,EBTL and 6,WBTL, Start of Green												
Natural Cycle: 45												
Control Type: Actuated-Coordinated												

Lanes, Volumes, Timings  
8: Bayswater & Gladstone

HCM Signalized Intersection Capacity Analysis  
8: Bayswater & Gladstone

951 Gladstone & 145 Loretta  
Future Total-AM Peak Hour

Maximum v/c Ratio: 0.37  
Intersection Signal Delay: 12.3  
Intersection Capacity Utilization 49.2%  
Analysis Period (min) 15

EBL EBT EBR WBL WBT WBR NBL NBT SBL SBT SBR  
Future Total-AM Peak Hour

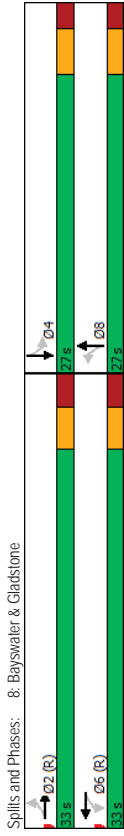

Movement	EBL	EBT	EBR	WBL	WBT	WBR	NBL	NBT	SBL	SBT	SBR
Lane Configurations											
Traffic Volume (vph)	23	217	16	14	123	35	19	106	22	50	124
Future Volume (vph)	23	217	16	14	123	35	19	106	22	50	124
Ideal Flow (vphpl)	1800	1800	1800	1800	1800	1800	1800	1800	1800	1800	1800
Total Lost time (s)	5.5			5.5			5.3				5.3
Lane Util. Factor	1.00	1.00	1.00	1.00	1.00	1.00	1.00	1.00	1.00	1.00	1.00
Frb. ped/bikes	0.99			0.99			0.99				0.99
Fllb. ped/bikes	1.00	1.00	1.00	1.00	1.00	1.00	1.00	1.00	1.00	1.00	1.00
Frt	0.99			0.97			0.98				0.98
Flt Protected	1.00	1.00	1.00	1.00	1.00	1.00	1.00	1.00	1.00	1.00	1.00
Satd. Flow (prot)	1707			1662			1685				1668
Flt Permitted	0.97			0.97			0.95				0.90
Satd. Flow (perm)	1661			1619			1612				1522
Peak-hour factor, PHF	1.00	1.00	1.00	1.00	1.00	1.00	1.00	1.00	1.00	1.00	1.00
Adj. Flow (vph)	23	217	16	14	123	35	19	106	22	50	124
RTOR Reduction (vph)	0	4	0	0	15	0	0	11	0	0	13
Lane Group Flow (vph)	0	252	0	0	157	0	0	136	0	0	198
Confl. Peds. (#/hr)	20	16	16	20	3	10	10	10	10	10	3
Confl. Bikes (#/hr)	65			21			12				7

Turn Type	Perm	NA	Perm	NA	Perm	NA	Perm	NA	Perm	NA
Protected Phases	2		6		8					
Permitted Phases	2		6		8		4			
Actuated Green, G (s)	27.5		27.5		21.7		21.7			
Effective Green, g (s)	27.5		27.5		21.7		21.7			
Actuated g/C Ratio	0.46		0.46		0.36		0.36			
Clearance Time (s)	5.5		5.5		5.3		5.3			
Vehicle Extension (s)	3.0		3.0		3.0		3.0			
Lane Grp Cap (vph)	761		742		583		550			
v/s Ratio Prot	c0.15		0.10		0.08		c0.13			
v/c Ratio	0.33		0.21		0.23		0.36			
Uniform Delay, d1	10.4		9.7		13.4		14.1			
Progression Factor	1.00		1.00		1.00		1.00			
Incremental Delay, d2	1.2		0.6		0.9		1.8			
Delay (s)	11.5		10.4		14.3		15.9			
Level of Service	B		B		B		B			
Approach Delay (s)	11.5		10.4		14.3		15.9			
Approach LOS	B		B		B		B			

Intersection Summary	Value	Level of Service
HCM 2000 Control Delay	13.0	B
HCM 2000 Volume to Capacity ratio	0.34	
Actuated Cycle Length (s)	60.0	
Intersection Capacity Utilization	49.2%	A
Analysis Period (min)	15	
c Critical Lane Group		

Intersection Summary	Value	Level of Service
HCM 2000 Control Delay	13.0	B
HCM 2000 Volume to Capacity ratio	0.34	
Actuated Cycle Length (s)	60.0	
Intersection Capacity Utilization	49.2%	A
Analysis Period (min)	15	
c Critical Lane Group		

Lanes, Volumes, Timings  
9: Gladstone

Lanes, Volumes, Timings  
9: Gladstone

951 Gladstone & 145 Loretta  
Future Total-AM Peak Hour

951 Gladstone & 145 Loretta  
Future Total-AM Peak Hour

Lane Group	EBL	EFT	EBR	WBL	WBT	WBR	NBL	NBT	NBR	SBL	SBT	SBR
Lane Configurations												
Traffic Volume (vph)	0	237	0	0	206	0	0	0	0	0	0	0
Future Volume (vph)	0	237	0	0	206	0	0	0	0	0	0	0
Satd. Flow (prot)	0	1745	0	0	1745	0	0	0	0	0	0	0
Flt Permitted												
Satd. Flow (perm)	0	1745	0	0	1745	0	0	0	0	0	0	0
Satd. Flow (RTOR)												
Lane Group Flow (vph)	0	237	0	0	206	0	0	0	0	0	0	0
Turn Type	NA	NA	NA	NA	NA	NA	NA	NA	NA	NA	NA	NA
Protected Phases	2	2	2	6	6	6	6	6	6	6	6	6
Permitted Phases												
Detector Phase	2	2	2	6	6	6	6	6	6	6	6	6
Switch Phase												
Minimum Initial (s)	10.0	10.0	10.0	10.0	10.0	10.0	10.0	10.0	10.0	10.0	10.0	10.0
Minimum Split (s)	22.5	22.5	22.5	22.5	22.5	22.5	22.5	22.5	22.5	22.5	22.5	22.5
Total Split (s)	50.0	50.0	50.0	50.0	50.0	50.0	50.0	50.0	50.0	50.0	50.0	50.0
Total Split (%)	71.4%	71.4%	71.4%	71.4%	71.4%	71.4%	71.4%	71.4%	71.4%	71.4%	71.4%	71.4%
Yellow Time (s)	3.0	3.0	3.0	3.0	3.0	3.0	3.0	3.0	3.0	3.0	3.0	3.0
All-Red Time (s)	1.9	1.9	1.9	1.9	1.9	1.9	1.9	1.9	1.9	1.9	1.9	1.9
Lost Time Adjust (s)	0.0	0.0	0.0	0.0	0.0	0.0	0.0	0.0	0.0	0.0	0.0	0.0
Total Lost Time (s)	4.9	4.9	4.9	4.9	4.9	4.9	4.9	4.9	4.9	4.9	4.9	4.9
Lead/Lag												
Lead-Lag Optimize?												
Recall Mode	C-Max	C-Max	C-Max	C-Max	C-Max	C-Max	C-Max	C-Max	C-Max	C-Max	C-Max	C-Max
Act Effct Green (s)	56.8	56.8	56.8	56.8	56.8	56.8	56.8	56.8	56.8	56.8	56.8	56.8
Actuated g/C Ratio	0.81	0.81	0.81	0.81	0.81	0.81	0.81	0.81	0.81	0.81	0.81	0.81
v/c Ratio	0.17	0.17	0.17	0.15	0.15	0.15	0.15	0.15	0.15	0.15	0.15	0.15
Control Delay	0.0	3.5	2.0	0.0	2.0	0.0	0.0	0.0	0.0	0.0	0.0	0.0
Queue Delay	0.0	0.0	0.0	0.0	0.0	0.0	0.0	0.0	0.0	0.0	0.0	0.0
Total Delay	3.5	3.5	2.0	0.0	2.0	0.0	0.0	0.0	0.0	0.0	0.0	0.0
LOS	A	A	A	A	A	A	A	A	A	A	A	A
Approach Delay	3.5	3.5	2.0	0.0	2.0	0.0	0.0	0.0	0.0	0.0	0.0	0.0
Approach LOS	A	A	A	A	A	A	A	A	A	A	A	A
Queue Length 50th (m)	9.3	9.3	3.2	0.0	3.2	0.0	0.0	0.0	0.0	0.0	0.0	0.0
Queue Length 95th (m)	16.3	16.3	11.8	0.0	11.8	0.0	0.0	0.0	0.0	0.0	0.0	0.0
Internal Link Dist (m)	136.1	136.1	140.4	0.0	140.4	0.0	0.0	0.0	0.0	0.0	0.0	0.0
Turn Bay Length (m)				3.1	3.1							12.7
Base Capacity (vph)	1416	1416	1416	1416	1416	1416	1416	1416	1416	1416	1416	1416
Starvation Cap Reductn	0	0	0	0	0	0	0	0	0	0	0	0
Spillback Cap Reductn	0	0	0	0	0	0	0	0	0	0	0	0
Storage Cap Reductn	0	0	0	0	0	0	0	0	0	0	0	0
Reduced v/c Ratio	0.17	0.17	0.15	0.15	0.15	0.15	0.15	0.15	0.15	0.15	0.15	0.15
Intersection Summary												
Cycle Length: 70												
Actuated Cycle Length: 70												
Offset: 0 (0%), Referenced to phase 2:EFT and 6:WBT, Start of Green												
Natural Cycle: 45												
Control Type: Actuated-Coordinated												

Lanes, Volumes, Timings  
9. Gladstone

HCM Signalized Intersection Capacity Analysis  
9. Gladstone

951 Gladstone & 145 Loretta  
Future Total-AM Peak Hour

Maximum v/c Ratio: 0.17  
Intersection Signal Delay: 2.8  
Intersection Capacity Utilization: 17.3%  
Analysis Period (min): 15

Future Total-AM Peak Hour  
SBR SBT SBL NBR NBL NBT NBL WBR WBT WBL EBR EBT EBL

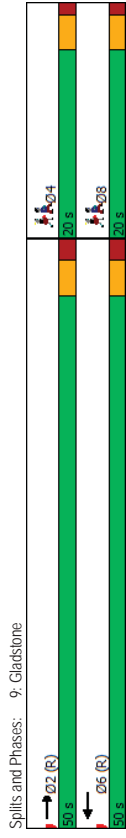

Movement	EBL	EBT	EBR	WBL	WBT	WBR	NBL	NBT	NBR	SBL	SBT	SBR	
Lane Configurations													
Traffic Volume (vph)	0	237	0	0	206	0	0	0	0	0	0	0	
Future Volume (vph)	0	237	0	0	206	0	0	0	0	0	0	0	
Ideal Flow (vphpl)	1800	1800	1800	1800	1800	1800	1800	1800	1800	1800	1800	1800	
Total Lost time (s)	4.9				4.9								
Lane Util. Factor	1.00	1.00	1.00	1.00	1.00	1.00	1.00	1.00	1.00	1.00	1.00	1.00	
Flt	1.00	1.00	1.00	1.00	1.00	1.00	1.00	1.00	1.00	1.00	1.00	1.00	
Flt Protected	1.00	1.00	1.00	1.00	1.00	1.00	1.00	1.00	1.00	1.00	1.00	1.00	
Satd. Flow (prot)	1745	1745	1745	1745	1745	1745	1745	1745	1745	1745	1745	1745	
Flt Permitted	1.00	1.00	1.00	1.00	1.00	1.00	1.00	1.00	1.00	1.00	1.00	1.00	
Satd. Flow (perm)	1745	1745	1745	1745	1745	1745	1745	1745	1745	1745	1745	1745	
Peak-hour factor, PHF	1.00	1.00	1.00	1.00	1.00	1.00	1.00	1.00	1.00	1.00	1.00	1.00	
Adj. Flow (vph)	0	237	0	0	206	0	0	0	0	0	0	0	
RTOR Reduction (vph)	0	0	0	0	0	0	0	0	0	0	0	0	
Lane Group Flow (vph)	0	237	0	0	206	0	0	0	0	0	0	0	
Turn Type	NA	NA	NA	NA	NA	NA	NA	NA	NA	NA	NA	NA	
Protected Phases	2				6								
Permitted Phases													
Actuated Green, G (s)	53.2				53.2								
Effective Green, g (s)	53.2				53.2								
Actuated g/C Ratio	0.76				0.76								
Clearance Time (s)	4.9				4.9								
Vehicle Extension (s)	3.0				3.0								
Lane Grp Cap (vph)	1326				1326								
v/s Ratio Prot	c0.14				0.12								
v/c Ratio	0.18				0.16								
Uniform Delay, d1	2.3				2.3								
Progression Factor	1.00				0.56								
Incremental Delay, d2	0.3				0.2								
Delay (s)	2.6				1.5								
Level of Service	A				A								
Approach Delay (s)	2.6				1.5							0.0	
Approach LOS	A				A							A	
<b>Intersection Summary</b>													
HCM 2000 Control Delay	2.1											HCM 2000 Level of Service	A
HCM 2000 Volume to Capacity ratio	0.16												
Actuated Cycle Length (s)	70.0											Sum of lost time (s)	9.0
Intersection Capacity Utilization	17.3%											ICU Level of Service	A
Analysis Period (min)	15												
c. Critical Lane Group													

951 Gladstone & 145 Loretta  
Future Total - PM Peak Hour

Lanes, Volumes, Timings  
2: Preston & Gladstone

951 Gladstone & 145 Loretta  
Future Total - PM Peak Hour

Intersection	1.4														
Init Delay, s/veh															
Movement	EBL	EBT	EBR	WBL	WBT	WBR	NBL	NBT	NBR	SBL	SBT	SBR			
Lane Configurations															
Traffic Vol, veh/h	17	210	4	6	637	27	3	0	1	28	0	23			
Future Vol, veh/h	17	210	4	6	637	27	3	0	1	28	0	23			
Conflicting Peds, #/hr	26	0	25	0	25	0	26	7	0	10	10	0	7		
Sign Control	Free	Free	Free	Free	Free	Free	Free	Free	Free	Free	Free	Free	Stop	Stop	
RT Channelized	-	-	None	-	-	None	-	-	None	-	-	None	-	None	
Storage Length	-	-	-	-	-	-	-	-	-	-	-	-	-	-	
Veh in Median Storage, #	-	0	-	-	0	-	-	-	0	-	-	0	-	-	
Grade, %	-	0	-	-	0	-	-	-	0	-	-	0	-	-	
Peak Hour Factor	100	100	100	100	100	100	100	100	100	100	100	100	-	-	
Heavy Vehicles, %	2	2	2	2	2	2	2	2	2	2	2	2	-	-	
Mvmt Flow	17	210	4	6	637	27	3	0	1	28	0	23	-	-	
Major/Minor	Major1	Major2	Minor1	Minor2	Minor1	Minor2	Minor1	Minor2	Minor1	Minor2	Minor1	Minor2			
Conflicting Flow All	690	0	0	239	0	0	952	973	247	946	962	684			
Stage 1	-	-	-	-	-	-	-	271	271	-	689	689	-	-	
Stage 2	-	-	-	-	-	-	-	681	702	-	257	273	-	-	
Critical Hdwy	412	-	-	412	-	-	712	652	622	712	652	622			
Critical Hdwy Stg 1	-	-	-	-	-	-	-	612	552	-	612	552	-	-	
Critical Hdwy Stg 2	-	-	-	-	-	-	-	612	552	-	612	552	-	-	
Follow-up Hdwy	2.218	-	-	2.218	-	-	3.518	4.018	3.318	3.518	4.018	3.318			
Pot Cap-1 Maneuver	905	-	-	1328	-	-	239	252	792	241	256	449			
Stage 1	-	-	-	-	-	-	-	735	685	-	436	446	-	-	
Stage 2	-	-	-	-	-	-	-	440	440	-	748	684	-	-	
Platoon blocked, %	-	-	-	-	-	-	-	-	-	-	-	-	-	-	
Mov Cap-1 Maneuver	887	-	-	1302	-	-	216	235	771	229	239	438			
Mov Cap-2 Maneuver	-	-	-	-	-	-	-	216	235	-	229	239	-	-	
Stage 1	-	-	-	-	-	-	-	705	657	-	418	434	-	-	
Stage 2	-	-	-	-	-	-	-	412	428	-	725	656	-	-	
Approach	EB	WB	NB	SB	WB	NB	SB	WB	NB	SB	WB	NB	SB		
HCM Control Delay, s	0.7	0.1	18.9	19.9	18.9	19.9	19.9	19.9	19.9	19.9	19.9	19.9			
HCM LOS	C	C	C	C	C	C	C	C	C	C	C	C			
Minor Lane/Major Mvmt	NBLn1	EBL	EBT	EBR	WBL	WBT	WBR	SBLn1	EBL	EBT	EBR	SBLn1			
Capacity (veh/h)	263	887	-	-	1302	-	-	292	263	887	-	292			
HCM Lane V/C Ratio	0.015	0.019	-	-	0.005	-	-	0.175	0.015	0.019	-	0.175			
HCM Control Delay (s)	18.9	9.1	0	-	7.8	0	-	19.9	18.9	9.1	0	19.9			
HCM Lane LOS	C	A	A	A	A	A	A	C	C	A	A	C			
HCM 95th %ile Q(veh)	0	0.1	-	-	0	-	-	0.6	0	0.1	-	0.6			

Lane Group	EBL	EBT	EBR	WBL	WBT	WBR	NBL	NBT	NBR	SBL	SBT	SBR
Lane Configurations												
Traffic Volume (vph)	25	198	57	80	489	77	92	374	101	52	364	56
Future Volume (vph)	25	198	57	80	489	77	92	374	101	52	364	56
Satd. Flow (prot)	0	1639	0	1658	1665	0	1658	1633	0	1658	1657	0
FltP/Permitted	0.778			0.572			0.415					0.361
Satd. Flow (perm)	0	1275	0	933	1665	0	655	1633	0	597	1657	0
Lane Group Flow (vph)	0	280	0	80	566	0	92	475	0	52	420	0
Turn Types	Perm	NA	Perm	NA	Perm	NA	Perm	NA	Perm	NA	Perm	NA
Permitted Phases	4	4	8	8	8	8	2	2	2	6	6	6
Detector Phase	4	4	8	8	8	8	2	2	2	6	6	6
Switch Phase	4	4	8	8	8	8	2	2	2	6	6	6
Minimum Initial (s)	10.0	10.0	10.0	10.0	10.0	10.0	10.0	10.0	10.0	10.0	10.0	10.0
Minimum Split (s)	24.5	24.5	24.5	24.5	24.5	24.5	23.7	23.7	23.7	23.7	23.7	23.7
Total Split (s)	33.0	33.0	33.0	33.0	33.0	33.0	37.0	37.0	37.0	37.0	37.0	37.0
Total Spill (%)	47.1%	47.1%	47.1%	47.1%	47.1%	47.1%	52.9%	52.9%	52.9%	52.9%	52.9%	52.9%
Yellow Time (s)	3.0	3.0	3.0	3.0	3.0	3.0	3.3	3.3	3.3	3.3	3.3	3.3
All-Red Time (s)	3.5	3.5	3.5	3.5	3.5	3.5	2.4	2.4	2.4	2.4	2.4	2.4
Lost Time Adjust (s)	0.0	0.0	0.0	0.0	0.0	0.0	0.0	0.0	0.0	0.0	0.0	0.0
Total Lost Time (s)	6.5	6.5	6.5	6.5	6.5	6.5	5.7	5.7	5.7	5.7	5.7	5.7
Lead-Lag Optimize?												
Recall Mode	None	None	None	None	None	None	C	C	C	C	C	C
Act Effct Green (s)	26.7	26.7	26.7	26.7	26.7	26.7	31.1	31.1	31.1	31.1	31.1	31.1
Actuated G/C Ratio	0.38	0.38	0.38	0.38	0.38	0.38	0.44	0.44	0.44	0.44	0.44	0.44
v/c Ratio	0.58	0.23	0.88	0.23	0.88	0.32	0.64	0.64	0.20	0.57	0.20	0.57
Control Delay	20.1	20.1	16.1	37.3	17.2	17.2	19.7	19.7	15.0	18.8	15.0	18.8
Queue Delay	0.0	0.0	0.0	0.0	0.0	0.0	0.0	0.0	0.0	0.0	0.0	0.0
Total Delay	20.1	20.1	16.1	37.3	17.2	17.2	19.7	19.7	15.0	18.8	15.0	18.8
LOS	C	C	B	D	B	D	B	B	B	B	B	B
Approach Delay	20.1	20.1	34.7	19.3	19.3	19.3	19.3	19.3	18.4	18.4	18.4	18.4
Approach LOS	C	C	C	C	C	C	C	C	C	C	C	C
Queue Length 50th (m)	19.1	6.3	60.3	8.1	47.9	8.1	47.9	47.9	4.3	42.8	4.3	42.8
Queue Length 95th (m)	51.2	16.1	#123.3	17.8	72.9	17.8	72.9	72.9	10.7	64.4	10.7	64.4
Internal Link Dist (m)	137.4			149.8			122.5				139.6	
Turn Bay Length (m)				37.5			24.0				28.0	
Base Capacity (vph)	503	368	665	301	766	301	766	766	274	763	274	763
Starvation Cap Reductn	0	0	0	0	0	0	0	0	0	0	0	0
Spillback Cap Reductn	0	0	0	0	0	0	0	0	0	0	0	0
Storage Cap Reductn	0	0	0	0	0	0	0	0	0	0	0	0
Reduced v/c Ratio	0.56	0.22	0.85	0.31	0.62	0.31	0.62	0.62	0.19	0.55	0.19	0.55
Intersection Summary												
Cycle Length: 70												
Actuated Cycle Length: 70												
Offset: 40 (57%), Referenced to phase 2:NBTL and 6:SBTL, Start of Green												
Natural Cycle: 55												
Control Type: Actuated-Coordinated												

Lanes, Volumes, Timings  
 2: Preston & Gladstone

HCM Signalized Intersection Capacity Analysis  
 2: Preston & Gladstone

951 Gladstone & 145 Loretta  
 Future Total - PM Peak Hour

Maximum v/c Ratio: 0.88  
 Intersection Signal Delay: 24.3  
 Intersection Capacity Utilization 89.6%  
 Analysis Period (min) 15  
 # 95th percentile volume exceeds capacity, queue may be longer.  
 Queue shown is maximum after two cycles.

Future Total - PM Peak Hour  
 EBL EBT EBR WBL WBT WBR NBL NBT NBR SBL SBT SBR  
 Lane Configurations  
 Traffic Volume (vph)  
 Future Volume (vph)  
 Ideal Flow (vph)  
 Total Lost time (s)  
 Lane Util. Factor  
 Frpb, ped/bikes  
 Flbb, ped/bikes  
 Frt  
 Fil Protected  
 Sald. Flow (prot)  
 Fil Permitted  
 Sald. Flow (perm)  
 Peak-hour factor, PHF  
 Adj. Flow (vph)  
 RTOR Reduction (vph)  
 Lane Group Flow (vph)  
 Confl. Peds. (#/hr)  
 Confl. Bikes (#/hr)

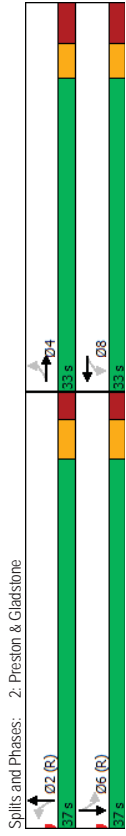

Movement	EBL	EBT	EBR	WBL	WBT	WBR	NBL	NBT	NBR	SBL	SBT	SBR
Lane Util. Factor	1.00	1.00	1.00	1.00	1.00	1.00	1.00	1.00	1.00	1.00	1.00	1.00
Frpb, ped/bikes	0.97	1.00	0.97	1.00	0.97	1.00	0.97	1.00	0.97	1.00	0.97	1.00
Flbb, ped/bikes	1.00	0.93	1.00	0.93	1.00	0.90	1.00	0.90	1.00	0.95	1.00	0.98
Frt	0.97	1.00	0.98	1.00	0.98	1.00	0.97	1.00	0.97	1.00	0.98	1.00
Fil Protected	1.00	1.00	0.95	1.00	0.95	1.00	0.95	1.00	0.95	1.00	0.95	1.00
Sald. Flow (prot)	1631	1549	1664	1500	1633	1570	1657	1570	1657	1570	1657	1570
Fil Permitted	0.78	0.57	1.00	0.41	1.00	0.36	1.00	0.36	1.00	0.57	1.00	0.36
Sald. Flow (perm)	1274	933	1664	655	1633	597	1657	597	1657	655	1633	597
Peak-hour factor, PHF	1.00	1.00	1.00	1.00	1.00	1.00	1.00	1.00	1.00	1.00	1.00	1.00
Adj. Flow (vph)	25	198	57	80	489	77	92	374	101	52	364	56
RTOR Reduction (vph)	0	0	0	0	8	0	0	14	0	0	0	0
Lane Group Flow (vph)	0	280	0	80	558	0	92	461	0	52	420	0
Confl. Peds. (#/hr)	73	51	51	73	106	68	68	106	68	68	106	68
Confl. Bikes (#/hr)	27	27	27	21	21	21	21	21	21	21	21	21

Turn Type	Perm	NA	NA	Perm	NA	Perm	NA	Perm	NA	Perm	NA
Protected Phases	4		8		2		6		6		6
Permitted Phases	4		8		2		6		6		6
Actuated Green, G (s)	26.7	26.7	26.7	31.1	31.1	31.1	31.1	31.1	31.1	31.1	31.1
Effective Green, g (s)	26.7	26.7	26.7	31.1	31.1	31.1	31.1	31.1	31.1	31.1	31.1
Actuated g/C Ratio	0.38	0.38	0.38	0.44	0.44	0.44	0.44	0.44	0.44	0.44	0.44
Clearance Time (s)	6.5	6.5	6.5	5.7	5.7	5.7	5.7	5.7	5.7	5.7	5.7
Vehicle Extension (s)	3.0	3.0	3.0	3.0	3.0	3.0	3.0	3.0	3.0	3.0	3.0
Lane Grp Cap (vph)	485	355	634	291	725	265	736	265	736	265	736
v/s Ratio Prot	0.22	0.09	0.14	0.32	0.28	0.09	0.25	0.09	0.25	0.09	0.25
v/c Ratio	0.58	0.23	0.88	0.32	0.64	0.20	0.57	0.20	0.57	0.20	0.57
Uniform Delay, d1	17.2	14.7	20.2	12.6	15.1	11.8	14.5	11.8	14.5	11.8	14.5
Progression Factor	0.87	1.00	1.00	1.00	1.00	1.00	1.00	1.00	1.00	1.00	1.00
Incremental Delay, d2	1.7	0.3	13.5	2.8	4.2	1.7	3.2	1.7	3.2	1.7	3.2
Delay (s)	16.6	15.0	33.6	15.4	19.3	13.5	17.7	13.5	17.7	13.5	17.7
Level of Service	B	B	C	B	B	B	B	B	B	B	B
Approach Delay (s)	16.6		31.3		18.7		17.2		17.2		17.2
Approach LOS	B		C		B		B		B		B

Intersection Summary	Value	Level of Service
HCM 2000 Control Delay	22.2	C
HCM 2000 Volume to Capacity ratio	0.75	
Actuated Cycle Length (s)	70.0	12.2
Intersection Capacity Utilization	89.6%	E
Analysis Period (min)	15	
c Critical Lane Group		

HCM 2010 TWSC  
3: Breezehill & Somersset  
951 Gladstone & 145 Loretta  
Future Total - PM Peak Hour

Intersection	1.1																																																																																																																																		
Int Delay, s/veh	EBT	EBR	WBL	WBT	NBL	NBR																																																																																																																													
Movement	316	27	20	418	27	18																																																																																																																													
Lane Configurations	<table border="0"> <tr> <td>Traffic Vol, veh/h</td> <td>316</td> <td>27</td> <td>20</td> <td>418</td> <td>27</td> <td>18</td> <td colspan="4"></td> </tr> <tr> <td>Future Vol, veh/h</td> <td>316</td> <td>27</td> <td>20</td> <td>418</td> <td>27</td> <td>18</td> <td colspan="4"></td> </tr> <tr> <td>Conflicting Peds, #/hr</td> <td>0</td> <td>100</td> <td>100</td> <td>0</td> <td>19</td> <td>0</td> <td colspan="4"></td> </tr> <tr> <td>Sign Control</td> <td>Free</td> <td>Free</td> <td>Free</td> <td>Free</td> <td>Stop</td> <td>Stop</td> <td colspan="4"></td> </tr> <tr> <td>RT Channelized</td> <td>-</td> <td>None</td> <td>-</td> <td>None</td> <td>-</td> <td>None</td> <td colspan="4"></td> </tr> <tr> <td>Storage Length</td> <td>-</td> <td>-</td> <td>-</td> <td>-</td> <td>-</td> <td>0</td> <td colspan="4"></td> </tr> <tr> <td>Veh in Median Storage, #</td> <td>0</td> <td>-</td> <td>-</td> <td>0</td> <td>0</td> <td>-</td> <td colspan="4"></td> </tr> <tr> <td>Grade, %</td> <td>0</td> <td>-</td> <td>-</td> <td>0</td> <td>0</td> <td>-</td> <td colspan="4"></td> </tr> <tr> <td>Peak Hour Factor</td> <td>100</td> <td>100</td> <td>100</td> <td>100</td> <td>100</td> <td>100</td> <td colspan="4"></td> </tr> <tr> <td>Heavy Vehicles, %</td> <td>2</td> <td>2</td> <td>2</td> <td>2</td> <td>2</td> <td>2</td> <td colspan="4"></td> </tr> <tr> <td>Mvmt Flow</td> <td>316</td> <td>27</td> <td>20</td> <td>418</td> <td>27</td> <td>18</td> <td colspan="4"></td> </tr> </table>										Traffic Vol, veh/h	316	27	20	418	27	18					Future Vol, veh/h	316	27	20	418	27	18					Conflicting Peds, #/hr	0	100	100	0	19	0					Sign Control	Free	Free	Free	Free	Stop	Stop					RT Channelized	-	None	-	None	-	None					Storage Length	-	-	-	-	-	0					Veh in Median Storage, #	0	-	-	0	0	-					Grade, %	0	-	-	0	0	-					Peak Hour Factor	100	100	100	100	100	100					Heavy Vehicles, %	2	2	2	2	2	2					Mvmt Flow	316	27	20	418	27	18				
Traffic Vol, veh/h	316	27	20	418	27	18																																																																																																																													
Future Vol, veh/h	316	27	20	418	27	18																																																																																																																													
Conflicting Peds, #/hr	0	100	100	0	19	0																																																																																																																													
Sign Control	Free	Free	Free	Free	Stop	Stop																																																																																																																													
RT Channelized	-	None	-	None	-	None																																																																																																																													
Storage Length	-	-	-	-	-	0																																																																																																																													
Veh in Median Storage, #	0	-	-	0	0	-																																																																																																																													
Grade, %	0	-	-	0	0	-																																																																																																																													
Peak Hour Factor	100	100	100	100	100	100																																																																																																																													
Heavy Vehicles, %	2	2	2	2	2	2																																																																																																																													
Mvmt Flow	316	27	20	418	27	18																																																																																																																													

Major/Minor	Major1	Major2	Minor1							
Conflicting Flow All	0	0	443	0	907	430				
Stage 1	-	-	-	-	430	-				
Stage 2	-	-	-	-	477	-				
Critical Hdwy	-	-	4.12	-	6.42	6.22				
Critical Hdwy Stg 1	-	-	-	-	5.42	-				
Critical Hdwy Stg 2	-	-	-	-	5.42	-				
Follow-up Hdwy	-	-	2.218	-	3.518	3.318				
Pot Cap-1 Maneuver	-	-	1117	-	306	625				
Stage 1	-	-	-	-	656	-				
Stage 2	-	-	-	-	624	-				
Platoon blocked, %	-	-	-	-	-	-				
Mov Cap-1 Maneuver	-	-	1030	-	271	576				
Mov Cap-2 Maneuver	-	-	-	-	271	-				
Stage 1	-	-	-	-	605	-				
Stage 2	-	-	-	-	600	-				
Approach	EB	WB	NB							
HCM Control Delay, s	0	0.4	17							
HCM LOS	C									
Minor Lane/Major Mvmt	NBLn1	EBT	EBR	WBL	WBT					
Capacity (veh/h)	344	-	-	1030	-					
HCM Lane V/C Ratio	0.131	-	-	0.019	-					
HCM Control Delay (s)	17	-	-	8.6	0					
HCM Lane LOS	C	-	-	A	A					
HCM 95th %ile Q(veh)	0.4	-	-	0.1	-					

HCM 2010 TWSC  
4: Loretta & Access #1  
951 Gladstone & 145 Loretta  
Future Total - PM Peak Hour

Intersection	0.8																																																																																																																																		
Int Delay, s/veh	WBL	WBR	NBT	NBR	SBL	SBT																																																																																																																													
Movement	5	5	50	0	0	45																																																																																																																													
Lane Configurations	<table border="0"> <tr> <td>Traffic Vol, veh/h</td> <td>5</td> <td>5</td> <td>50</td> <td>0</td> <td>0</td> <td>45</td> <td colspan="4"></td> </tr> <tr> <td>Future Vol, veh/h</td> <td>5</td> <td>5</td> <td>50</td> <td>0</td> <td>0</td> <td>45</td> <td colspan="4"></td> </tr> <tr> <td>Conflicting Peds, #/hr</td> <td>0</td> <td>0</td> <td>0</td> <td>0</td> <td>0</td> <td>0</td> <td colspan="4"></td> </tr> <tr> <td>Sign Control</td> <td>Stop</td> <td>Stop</td> <td>Free</td> <td>Free</td> <td>Free</td> <td>Free</td> <td colspan="4"></td> </tr> <tr> <td>RT Channelized</td> <td>-</td> <td>None</td> <td>-</td> <td>None</td> <td>-</td> <td>None</td> <td colspan="4"></td> </tr> <tr> <td>Storage Length</td> <td>0</td> <td>-</td> <td>-</td> <td>-</td> <td>-</td> <td>-</td> <td colspan="4"></td> </tr> <tr> <td>Veh in Median Storage, #</td> <td>0</td> <td>-</td> <td>0</td> <td>-</td> <td>-</td> <td>0</td> <td colspan="4"></td> </tr> <tr> <td>Grade, %</td> <td>0</td> <td>-</td> <td>0</td> <td>-</td> <td>-</td> <td>0</td> <td colspan="4"></td> </tr> <tr> <td>Peak Hour Factor</td> <td>100</td> <td>100</td> <td>100</td> <td>100</td> <td>100</td> <td>100</td> <td colspan="4"></td> </tr> <tr> <td>Heavy Vehicles, %</td> <td>2</td> <td>2</td> <td>2</td> <td>2</td> <td>2</td> <td>2</td> <td colspan="4"></td> </tr> <tr> <td>Mvmt Flow</td> <td>5</td> <td>5</td> <td>50</td> <td>0</td> <td>0</td> <td>45</td> <td colspan="4"></td> </tr> </table>										Traffic Vol, veh/h	5	5	50	0	0	45					Future Vol, veh/h	5	5	50	0	0	45					Conflicting Peds, #/hr	0	0	0	0	0	0					Sign Control	Stop	Stop	Free	Free	Free	Free					RT Channelized	-	None	-	None	-	None					Storage Length	0	-	-	-	-	-					Veh in Median Storage, #	0	-	0	-	-	0					Grade, %	0	-	0	-	-	0					Peak Hour Factor	100	100	100	100	100	100					Heavy Vehicles, %	2	2	2	2	2	2					Mvmt Flow	5	5	50	0	0	45				
Traffic Vol, veh/h	5	5	50	0	0	45																																																																																																																													
Future Vol, veh/h	5	5	50	0	0	45																																																																																																																													
Conflicting Peds, #/hr	0	0	0	0	0	0																																																																																																																													
Sign Control	Stop	Stop	Free	Free	Free	Free																																																																																																																													
RT Channelized	-	None	-	None	-	None																																																																																																																													
Storage Length	0	-	-	-	-	-																																																																																																																													
Veh in Median Storage, #	0	-	0	-	-	0																																																																																																																													
Grade, %	0	-	0	-	-	0																																																																																																																													
Peak Hour Factor	100	100	100	100	100	100																																																																																																																													
Heavy Vehicles, %	2	2	2	2	2	2																																																																																																																													
Mvmt Flow	5	5	50	0	0	45																																																																																																																													

Major/Minor	Minor1	Major1	Major2								
Conflicting Flow All	95	50	0	-	-	-					
Stage 1	50	-	-	-	-	-					
Stage 2	45	-	-	-	-	-					
Critical Hdwy	6.42	6.22	-	-	-	-					
Critical Hdwy Stg 1	5.42	-	-	-	-	-					
Critical Hdwy Stg 2	5.42	-	-	-	-	-					
Follow-up Hdwy	3,518	3,318	-	-	-	-					
Pot Cap-1 Maneuver	905	1018	-	0	0	-					
Stage 1	972	-	-	0	0	-					
Stage 2	977	-	-	0	0	-					
Platoon blocked, %	-	-	-	-	-	-					
Mov Cap-1 Maneuver	905	1018	-	-	-	-					
Mov Cap-2 Maneuver	905	-	-	-	-	-					
Stage 1	972	-	-	-	-	-					
Stage 2	977	-	-	-	-	-					
Approach	WB	NB	SB								
HCM Control Delay, s	8.8	0	0								
HCM LOS	A										
Minor Lane/Major Mvmt	NBTWBLn1	SBT									
Capacity (veh/h)	-	958	-								
HCM Lane V/C Ratio	-	0.01	-								
HCM Control Delay (s)	-	8.8	-								
HCM Lane LOS	-	A	-								
HCM 95th %ile Q(veh)	-	0	-								

HCM 2010 TWSC  
5: Loretta & Access #2

951 Gladstone & 145 Loretta  
6: Loretta & Gladstone

Future Total - PM Peak Hour

Future Total - PM Peak Hour

Intersection	4.2																
Int Delay, s/veh	3.8																
Movement	WBL	WBR	NBT	NBR	SBL	SBT	EBL	EBT	EBR	WBL	WBR	NBL	NBR	SBL	SBT	SBR	
Lane Configurations	4																
Traffic Vol, veh/h	82	10	40	40	7	43	28	205	4	9	593	15	0	6	61	2	62
Future Vol, veh/h	82	10	40	40	7	43	28	205	4	9	593	15	0	6	61	2	62
Conflicting Peds, #/hr	0	0	0	0	0	0	36	0	35	35	0	36	2	0	4	4	0
Sign Control	Stop	Stop	Free	Free	Free	Free	Free	Free	Free	Free	Free	Free	Free	Free	Free	Free	Free
RT Channelized	-	None	-	None	-	None	-	None	-	None	-	None	-	None	-	None	-
Storage Length	0	-	-	-	-	-	-	-	-	-	-	-	-	-	-	-	-
Veh in Median Storage, #	0	-	0	-	-	0	-	0	-	-	0	-	-	-	0	-	-
Grade, %	0	-	0	-	-	0	-	0	-	-	0	-	-	-	0	-	-
Peak Hour Factor	100	100	100	100	100	100	100	100	100	100	100	100	100	100	100	100	100
Heavy Vehicles, %	2	2	2	2	2	2	2	2	2	2	2	2	2	2	2	2	2
Mvmt Flow	82	10	40	40	7	43	28	205	4	9	593	15	0	6	61	2	62
Major/Minor	Minor1	Major1	Major1	Major2													
Conflicting Flow All	117	60	0	80	0	681	0	0	244	0	0	969	997	246	943	973	657
Stage 1	60	-	-	-	-	-	-	-	-	-	-	298	298	-	673	673	-
Stage 2	57	-	-	-	-	-	-	-	-	-	-	671	699	-	270	300	-
Critical Hdwy	6.42	6.22	-	4.12	-	4.12	-	4.12	-	4.12	-	7.12	6.52	6.22	7.12	6.52	6.22
Critical Hdwy Stg 1	5.42	-	-	-	-	-	-	-	-	-	-	6.12	5.52	-	6.12	5.52	-
Critical Hdwy Stg 2	5.42	-	-	-	-	-	-	-	-	-	-	6.12	5.52	-	6.12	5.52	-
Follow-up Hdwy	3.518	3.318	-	2.218	-	2.218	-	2.218	-	2.218	-	3.518	4.018	3.318	3.518	4.018	3.318
Pot Cap-1 Maneuver	879	1005	-	1518	-	912	-	1322	-	1322	-	233	244	793	243	252	465
Stage 1	963	-	-	-	-	711	667	-	-	-	-	711	667	-	445	454	-
Stage 2	966	-	-	-	-	446	442	-	-	-	-	446	442	-	736	666	-
Platoon blocked, %	-	-	-	-	-	-	-	-	-	-	-	-	-	-	-	-	-
Mov Cap-1 Maneuver	875	1005	-	1518	-	887	-	1286	-	1286	-	187	220	769	225	227	451
Mov Cap-2 Maneuver	875	-	-	-	-	-	-	-	-	-	-	187	220	-	225	227	-
Stage 1	963	-	-	-	-	-	-	-	-	-	-	667	626	-	417	436	-
Stage 2	961	-	-	-	-	-	-	-	-	-	-	378	425	-	702	625	-
Approach	WB	NB	SB														
HCM Control Delay, s	9.5	0	1														
HCM LOS	A																
Minor Lane/Major Mvmt	NBT	NBR	WBLn1	SBL	SBT												
Capacity (veh/h)	-	-	887	1518	-	239	887	-	1286	-	-	299	-	-	-	-	-
HCM Lane V/C Ratio	-	-	0.104	0.005	-	0.088	0.032	-	0.007	-	-	0.418	-	-	-	-	-
HCM Control Delay (s)	-	-	9.5	7.4	0	21.5	9.2	0	7.8	0	-	25.4	-	-	-	-	-
HCM Lane LOS	-	-	A	A	A	C	A	A	A	A	-	D	-	-	-	-	-
HCM 95th %ile Q(veh)	-	-	0.3	0	-	0.3	0.1	-	0	-	-	0	-	-	-	-	-

7: Breezehill & Laurel

951 Gladstone & 145 Loretta  
Future Total - PM Peak Hour

Intersection	shveh	7.3
Intersection Delay	A	

Movement	EBL	EBT	EBR	WBL	WBT	WBR	NBL	NBT	NBR	SBL	SBT	SBR
Lane Configurations	12	10	10	4	27	16	24	22	1	8	45	45
Traffic Vol, veh/h	12	10	10	4	27	16	24	22	1	8	45	45
Future Vol, veh/h	12	10	10	4	27	16	24	22	1	8	45	45
Peak Hour Factor	1.00	1.00	1.00	1.00	1.00	1.00	1.00	1.00	1.00	1.00	1.00	1.00
Heavy Vehicles, %	2	2	2	2	2	2	2	2	2	2	2	2
Mgmt Flow	12	10	10	4	27	16	24	22	1	8	45	45
Number of Lanes	0	1	0	0	1	0	0	1	0	0	1	0

Approach	EB	WB	WB	NB	NB	SB	SB
Opposing Approach	WB	EB	WB	EB	WB	WB	NB
Opposing Lanes	1	1	1	1	1	1	1
Conflicting Approach Left	SB	NB	NB	EB	EB	WB	WB
Conflicting Lanes Left	1	1	1	1	1	1	1
Conflicting Approach Right	NB	SB	SB	WB	WB	EB	EB
Conflicting Lanes Right	1	1	1	1	1	1	1
HCM Control Delay	7.3	7.3	7.3	7.5	7.5	7.3	7.3
HCM LOS	A	A	A	A	A	A	A

Lane	NBLnt	EBLnt1	WBLnt1	SBLnt1	SBLnt
Vol Left, %	51%	38%	9%	9%	
Vol Thru, %	47%	31%	57%	53%	
Vol Right, %	2%	31%	34%	38%	
Sign Control	Stop	Stop	Stop	Stop	
Traffic Vol by Lane	47	32	47	85	
LT Vol	24	12	4	8	
Through Vol	22	10	27	45	
RT Vol	1	10	16	32	
Lane Flow Rate	47	32	47	85	
Geometry Grp	1	1	1	1	
Degree of UHl (X)	0.055	0.036	0.052	0.092	
Departure Headway (Hd)	4.226	4.088	4	3.899	
Convergence, Y/N	Yes	Yes	Yes	Yes	
Cap	843	867	887	914	
Service Time	2.275	2.153	2.063	1.946	
HCM Lane V/C Ratio	0.056	0.037	0.053	0.093	
HCM Control Delay	7.5	7.3	7.3	7.3	
HCM Lane LOS	A	A	A	A	
HCM 95th-ile Q	0.2	0.1	0.2	0.3	

8: Bayswater & Gladstone

951 Gladstone & 145 Loretta  
Future Total - PM Peak Hour

Lane Group	EBL	EBT	EBR	WBL	WBT	WBR	NBL	NBT	NBR	SBL	SBT	SBR
Lane Configurations	10	168	18	74	475	114	29	182	28	35	206	34
Traffic Volume (vph)	10	168	18	74	475	114	29	182	28	35	206	34
Future Volume (vph)	0	1705	0	0	1665	0	0	1697	0	0	1694	0
Satd. Flow (prot)	0.966				0.942			0.935				0.934
Flt P/Permitted	0	1651	0	0	1571	0	0	1594	0	0	1589	0
Satd. Flow (RTOR)	12				25			12			12	
Lane Group Flow (vph)	0	196	0	0	663	0	0	239	0	0	275	0
Turn Types	Perm	NA	Perm	NA	Perm	NA	Perm	NA	Perm	NA	Perm	NA
Protected Phases	2	2	2	6	6	6	8	8	8	4	4	4
Permitted Phases	2	2	2	6	6	6	8	8	8	4	4	4
Detector Phase	2	2	2	6	6	6	8	8	8	4	4	4
Switch Phase												
Minimum Initial (s)	10.0	10.0	10.0	10.0	10.0	10.0	10.0	10.0	10.0	10.0	10.0	10.0
Minimum Split (s)	22.5	22.5	22.5	22.5	22.5	22.5	22.5	22.5	22.5	22.5	22.5	22.5
Total Split (s)	36.0	36.0	36.0	36.0	36.0	36.0	36.0	36.0	36.0	36.0	36.0	36.0
Total Spill (%)	60.0%	60.0%	60.0%	60.0%	60.0%	60.0%	60.0%	60.0%	60.0%	60.0%	60.0%	60.0%
Yellow Time (s)	3.0	3.0	3.0	3.0	3.0	3.0	3.3	3.3	3.3	3.3	3.3	3.3
All-Red Time (s)	2.5	2.5	2.5	2.5	2.5	2.5	2.0	2.0	2.0	2.0	2.0	2.0
Lost Time Adjust (s)	0.0	0.0	0.0	0.0	0.0	0.0	0.0	0.0	0.0	0.0	0.0	0.0
Total Lost Time (s)	5.5	5.5	5.5	5.5	5.5	5.5	5.3	5.3	5.3	5.3	5.3	5.3

Lead-Lag Optimize?	Recall Mode	C-Max	C-Max	C-Max	Max	Max
Act Effct Green (s)	30.5	30.5	30.5	18.7	18.7	18.7
Actuated g/C Ratio	0.51	0.51	0.51	0.31	0.31	0.31
v/c Ratio	0.23	0.82	0.82	0.47	0.55	0.55
Control Delay	8.6	22.9	22.9	19.6	21.3	21.3
Queue Delay	0.0	0.0	0.0	0.0	0.0	0.0
Total Delay	8.6	22.9	22.9	19.6	21.3	21.3
LOS	A	C	C	B	C	C
Approach Delay	8.6	22.9	22.9	19.6	21.3	21.3
Approach LOS	A	C	C	B	C	C
Queue Length 50th (m)	10.3	54.4	54.4	19.8	23.6	23.6
Queue Length 95th (m)	20.1	#114.3	#114.3	37.4	43.5	43.5
Internal Link Dist (m)	95.1	81.5	81.5	119.0	98.4	98.4
Turn Bay Length (m)						
Base Capacity (vph)	845	810	810	505	503	503
Starvation Cap Reductn	0	0	0	0	0	0
Spillback Cap Reductn	0	0	0	0	0	0
Storage Cap Reductn	0	0	0	0	0	0
Reduced v/c Ratio	0.23	0.82	0.82	0.47	0.55	0.55

Intersection Summary	Cycle Length: 60	Actuated Cycle Length: 60	Offset: 53 (88%), Referenced to phase 2,EBTL and 6,WBTL, Start of Green	Natural Cycle: 60	Control Type: Actuated-Coordinated
----------------------	------------------	---------------------------	---	-------------------	------------------------------------

Lanes, Volumes, Timings  
8: Bayswater & Gladstone

HCM Signalized Intersection Capacity Analysis  
8: Bayswater & Gladstone

951 Gladstone & 145 Loretta  
Future Total - PM Peak Hour

Maximum v/c Ratio: 0.82  
 Intersection Signal Delay: 19.9  
 Intersection LOS: B  
 Intersection Capacity Utilization 86.7%  
 ICU Level of Service E  
 Analysis Period (min) 15  
 # 95th percentile volume exceeds capacity, queue may be longer.  
 Queue shown is maximum after two cycles.

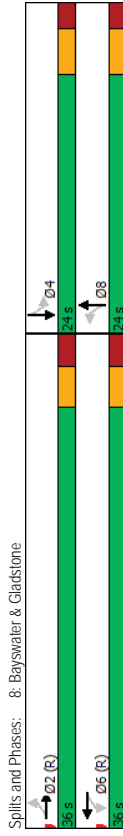

Movement	EBL	EBT	EBR	WBL	WBT	WBR	NBL	NBT	NBR	SBL	SBT	SBR	
Lane Configurations													
Traffic Volume (vph)	10	168	18	74	475	114	29	182	28	35	206	34	
Future Volume (vph)	10	168	18	74	475	114	29	182	28	35	206	34	
Ideal Flow (vphpl)	1800	1800	1800	1800	1800	1800	1800	1800	1800	1800	1800	1800	
Total Lost time (s)	5.5			5.5			5.3					5.3	
Lane Util. Factor	1.00	1.00	1.00	1.00	1.00	1.00	1.00	1.00	1.00	1.00	1.00	1.00	
Frb. ped/bikes	0.99			0.98			0.99				0.99	0.99	
Flbb. ped/bikes	1.00			1.00			1.00				1.00	1.00	
Frt	0.99			0.98			0.98				0.98	0.98	
Flt Protected	1.00			0.99			0.99				0.99	0.99	
Satd. Flow (prot)	1704			1658			1695				1691	1691	
Flt Permitted	0.97			0.94			0.94				0.94	0.93	
Satd. Flow (perm)	1651			1571			1595				1589	1589	
Peak-Hour factor, PHF	1.00	1.00	1.00	1.00	1.00	1.00	1.00	1.00	1.00	1.00	1.00	1.00	
Adj. Flow (vph)	10	168	18	74	475	114	29	182	28	35	206	34	
RTOR Reduction (vph)	0	6	0	0	12	0	0	8	0	0	8	0	
Lane Group Flow (vph)	0	190	0	0	651	0	0	231	0	0	267	0	
Confl. Peds. (#/hr)	25	27	27	27	25	13	13	13	13	13	13	13	
Confl. Bikes (#/hr)	24			54			3				7		
Turn Type	Perm	NA	NA	Perm	NA	Perm	NA	Perm	NA	Perm	NA	NA	
Protected Phases	2			6			8				4		
Permitted Phases	2			6			8				4		
Actuated Green, G (s)	30.5			30.5			18.7				18.7		
Effective Green, g (s)	30.5			30.5			18.7				18.7		
Actuated g/C Ratio	0.51			0.51			0.31				0.31		
Clearance Time (s)	5.5			5.5			5.3				5.3		
Vehicle Extension (s)	3.0			3.0			3.0				3.0		
Lane Grp Cap (vph)	839			798			497				495		
v/s Ratio Prot													
v/s Ratio Perm	0.12			c0.41			0.14				c0.17		
v/c Ratio	0.23			0.82			0.46				0.54		
Uniform Delay, d1	8.2			12.4			16.6				17.1		
Progression Factor	1.00			1.00			1.00				1.00		
Incremental Delay, d2	0.6			9.0			3.1				4.2		
Delay (s)	8.8			21.4			19.7				21.2		
Level of Service	A			C			B				C		
Approach Delay (s)	8.8			21.4			19.7				21.2		
Approach LOS	A			C			B				C		
<b>Intersection Summary</b>													
HCM 2000 Control Delay	19.3											HCM 2000 Level of Service	B
HCM 2000 Volume to Capacity ratio	0.71												
Actuated Cycle Length (s)	60.0											Sum of lost time (s)	10.8
Intersection Capacity Utilization	86.7%											ICU Level of Service	E
Analysis Period (min)	15												
c Critical Lane Group													

Lanes, Volumes, Timings  
9: Gladstone

Lanes, Volumes, Timings  
9: Gladstone

Future Total - PM Peak Hour

Future Total - PM Peak Hour

Lane Group	EBL	EBT	EBR	WBL	WBT	WBR	NBL	NBT	NBR	SBL	SBT	SBR
Lane Configurations												
Traffic Volume (vph)	0	231	0	0	633	0	0	0	0	0	0	0
Future Volume (vph)	0	231	0	0	633	0	0	0	0	0	0	0
Satd. Flow (prot)	0	1745	0	0	1745	0	0	0	0	0	0	0
Flt Permitted												
Satd. Flow (perm)	0	1745	0	0	1745	0	0	0	0	0	0	0
Satd. Flow (RTOR)												
Lane Group Flow (vph)	0	231	0	0	633	0	0	0	0	0	0	0
Turn Type	NA	NA			NA							
Protected Phases	2				6							
Permitted Phases												
Detector Phase	2				6							
Switch Phase												
Minimum Initial (s)	10.0				10.0							
Minimum Split (s)	22.5				22.5							
Total Split (s)	50.0				50.0							
Total Split (%)	71.4%				71.4%							
Yellow Time (s)	3.0				3.0							
All-Red Time (s)	1.9				1.9							
Lost Time Adjust (s)	0.0				0.0							
Total Lost Time (s)	4.9				4.9							
Lead/Lag												
Lead-Lag Optimize?												
Recall Mode	C-Max				C-Max							
Act Effct Green (s)	56.8				56.8							
Actuated g/C Ratio	0.81				0.81							
v/c Ratio	0.16				0.45							
Control Delay	3.5				2.9							
Queue Delay	0.0				0.0							
Total Delay	3.5				2.9							
LOS	A				A							
Approach Delay	3.5				2.9							
Approach LOS	A				A							
Queue Length 50th (m)	9.0				18.4							
Queue Length 95th (m)	15.8				m27.1							
Internal Link Dist (m)	139.1				137.4							
Turn Bay Length (m)										12.7		
Base Capacity (vph)	1416				1416							
Starvation Cap Reductn	0				0							
Spillback Cap Reductn	0				0							
Storage Cap Reductn	0				0							
Reduced v/c Ratio	0.16				0.45							
Intersection Summary												
Cycle Length: 70												
Actuated Cycle Length: 70												
Offset: 0 (0%), Referenced to phase 2:EBT and 6:WBT, Start of Green												
Natural Cycle: 50												
Control Type: Actuated-Coordinated												

97. Gladstone 951 Gladstone & 145 Loretta Future Total - PM Peak Hour

Maximum v/c Ratio: 0.45  
 Intersection Signal Delay: 3.0  
 Intersection Capacity Utilization: 39.3%  
 Analysis Period (min): 15  
 Volume for 95th percentile queue is metered by upstream signal.

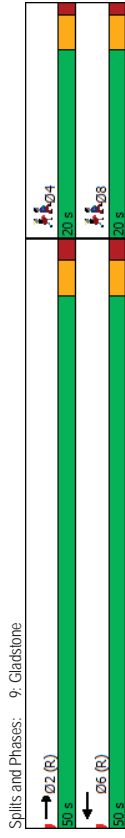

97. Gladstone HCM Signalized Intersection Capacity Analysis 951 Gladstone & 145 Loretta Future Total - PM Peak Hour

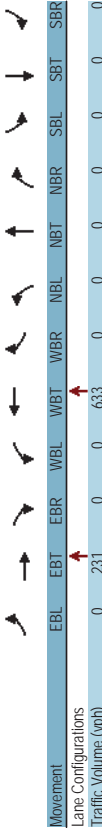

Movement	EBL	EBT	EBR	WBL	WBT	WBR	NBL	NBT	NBR	SBL	SBT	SBR
Lane Configurations												
Traffic Volume (vph)	0	231	0	0	633	0	0	0	0	0	0	0
Future Volume (vph)	0	231	0	0	633	0	0	0	0	0	0	0
Ideal Flow (vphpl)	1800	1800	1800	1800	1800	1800	1800	1800	1800	1800	1800	1800
Total Lost time (s)	4.9				4.9							
Lane Util. Factor	1.00	1.00	1.00	1.00	1.00	1.00	1.00	1.00	1.00	1.00	1.00	1.00
Frb. ped/bikes	1.00	1.00	1.00	1.00	1.00	1.00	1.00	1.00	1.00	1.00	1.00	1.00
Fllb. ped/bikes	1.00	1.00	1.00	1.00	1.00	1.00	1.00	1.00	1.00	1.00	1.00	1.00
Frt	1.00	1.00	1.00	1.00	1.00	1.00	1.00	1.00	1.00	1.00	1.00	1.00
Flt Protected	1.00	1.00	1.00	1.00	1.00	1.00	1.00	1.00	1.00	1.00	1.00	1.00
Satd. Flow (prot)	1745	1745	1745	1745	1745	1745	1745	1745	1745	1745	1745	1745
Flt Permitted	1.00	1.00	1.00	1.00	1.00	1.00	1.00	1.00	1.00	1.00	1.00	1.00
Satd. Flow (perm)	1745	1745	1745	1745	1745	1745	1745	1745	1745	1745	1745	1745
Peak-hour factor, PHF	1.00	1.00	1.00	1.00	1.00	1.00	1.00	1.00	1.00	1.00	1.00	1.00
Adj. Flow (vph)	0	231	0	0	633	0	0	0	0	0	0	0
RTOR Reduction (vph)	0	0	0	0	0	0	0	0	0	0	0	0
Lane Group Flow (vph)	0	231	0	0	633	0	0	0	0	0	0	0
Confl. Peds. (#/hr)	44	30	30	44	62	44	62	55	55	62	62	80
Confl. Bikes (#/hr)	10	10	10	10	10	10	10	80	80	10	10	80
Turn Type	NA	NA	NA	NA	NA	NA	NA	NA	NA	NA	NA	NA
Protected Phases	2	6										
Permitted Phases												
Actuated Green, G (s)	53.2	53.2	53.2	53.2	53.2	53.2	53.2	53.2	53.2	53.2	53.2	53.2
Effective Green, g (s)	53.2	53.2	53.2	53.2	53.2	53.2	53.2	53.2	53.2	53.2	53.2	53.2
Actuated g/C Ratio	0.76	0.76	0.76	0.76	0.76	0.76	0.76	0.76	0.76	0.76	0.76	0.76
Clearance Time (s)	4.9	4.9	4.9	4.9	4.9	4.9	4.9	4.9	4.9	4.9	4.9	4.9
Vehicle Extension (s)	3.0	3.0	3.0	3.0	3.0	3.0	3.0	3.0	3.0	3.0	3.0	3.0
Lane Grp Cap (vph)	1326	1326	1326	1326	1326	1326	1326	1326	1326	1326	1326	1326
v/s Ratio Prot	0.13	0.36										
v/s Ratio Perm	0.17	0.48										
v/c Ratio	2.3	3.2										
Uniform Delay, d1	1.00	0.51										
Progression Factor	0.3	0.8										
Incremental Delay, d2	2.6	2.4										
Delay (s)	A	A										
Level of Service	2.6	2.4										
Approach Delay (s)	A	A										
Approach LOS	A	A										
Intersection Summary												
HCM 2000 Control Delay	2.5	HCM 2000 Level of Service										
HCM 2000 Volume to Capacity ratio	0.42	A										
Actuated Cycle Length (s)	70.0	Sum of lost time (s)										
Intersection Capacity Utilization	39.3%	ICU Level of Service										
Analysis Period (min)	15	A										
c Critical Lane Group												

# Appendix G

TDM Checklist

**TDM Measures Checklist:**  
*Non-Residential Developments (office, institutional, retail or industrial)*

**Legend**

**BASIC** The measure is generally feasible and effective, and in most cases would benefit the development and its users

**BETTER** The measure could maximize support for users of sustainable modes, and optimize development performance

**★** The measure is one of the most dependably effective tools to encourage the use of sustainable modes

TDM measures: <i>Non-residential developments</i>		Check if proposed & add descriptions
<b>1. TDM PROGRAM MANAGEMENT</b>		
<b>1.1 Program coordinator</b>		
BASIC ★	1.1.1 Designate an internal coordinator, or contract with an external coordinator	<input checked="" type="checkbox"/>
<b>1.2 Travel surveys</b>		
BETTER	1.2.1 Conduct periodic surveys to identify travel-related behaviours, attitudes, challenges and solutions, and to track progress	<input type="checkbox"/>
<b>2. WALKING AND CYCLING</b>		
<b>2.1 Information on walking/cycling routes &amp; destinations</b>		
BASIC	2.1.1 Display local area maps with walking/cycling access routes and key destinations at major entrances	<input checked="" type="checkbox"/>
<b>2.2 Bicycle skills training</b>		
<i>Commuter travel</i>		
BETTER ★	2.2.1 Offer on-site cycling courses for commuters, or subsidize off-site courses	<input type="checkbox"/>
<b>2.3 Valet bike parking</b>		
<i>Visitor travel</i>		
BETTER	2.3.1 Offer secure valet bike parking during public events when demand exceeds fixed supply (e.g. for festivals, concerts, games)	<input type="checkbox"/>

**TDM measures: *Non-residential developments***

TDM measures: <i>Non-residential developments</i>		Check if proposed & add descriptions
<b>3. TRANSIT</b>		
<b>3.1 Transit information</b>		
BASIC	3.1.1 Display relevant transit schedules and route maps at entrances	<input checked="" type="checkbox"/>
BASIC	3.1.2 Provide online links to OC Transpo and STO information	<input checked="" type="checkbox"/>
BETTER	3.1.3 Provide real-time arrival information display at entrances	<input type="checkbox"/>
<b>3.2 Transit fare incentives</b>		
<i>Commuter travel</i>		
BETTER	3.2.1 Offer preloaded PRESTO cards to encourage commuters to use transit	<input checked="" type="checkbox"/>
BETTER ★	3.2.2 Subsidize or reimburse monthly transit pass purchases by employees	<input type="checkbox"/>
<i>Visitor travel</i>		
BETTER	3.2.3 Arrange inclusion of same-day transit fare in price of tickets (e.g. for festivals, concerts, games)	<input type="checkbox"/>
<b>3.3 Enhanced public transit service</b>		
<i>Commuter travel</i>		
BETTER	3.3.1 Contract with OC Transpo to provide enhanced transit services (e.g. for shift changes, weekends)	<input type="checkbox"/>
<i>Visitor travel</i>		
BETTER	3.3.2 Contract with OC Transpo to provide enhanced transit services (e.g. for festivals, concerts, games)	<input type="checkbox"/>
<b>3.4 Private transit service</b>		
<i>Commuter travel</i>		
BETTER	3.4.1 Provide shuttle service when OC Transpo cannot offer sufficient quality or capacity to serve demand (e.g. for shift changes, weekends)	<input type="checkbox"/>
<i>Visitor travel</i>		
BETTER	3.4.2 Provide shuttle service when OC Transpo cannot offer sufficient quality or capacity to serve demand (e.g. for festivals, concerts, games)	<input type="checkbox"/>

TDM measures: Non-residential developments		Check if proposed & add descriptions
<b>4. RIDESHARING</b>		
<i>Commuter travel</i>		
<b>BASIC</b> ★	4.1.1 Provide a dedicated ridesharing portal at OttawaRideMatch.com	<input type="checkbox"/>
<b>4.2 Carpool parking price incentives</b>		
<i>Commuter travel</i>		
<b>BETTER</b>	4.2.1 Provide discounts on parking costs for registered carpools	<input type="checkbox"/>
<b>4.3 Vanpool service</b>		
<i>Commuter travel</i>		
<b>BETTER</b>	4.3.1 Provide a vanpooling service for long-distance commuters	<input type="checkbox"/>
<b>5. CARSHARING &amp; BIKESHARING</b>		
<b>5.1 Bikeshare stations &amp; memberships</b>		
<b>BETTER</b>	5.1.1 Contract with provider to install on-site bikeshare station for use by commuters and visitors	<input checked="" type="checkbox"/>
<i>Commuter travel</i>		
<b>BETTER</b>	5.1.2 Provide employees with bikeshare memberships for local business travel	<input type="checkbox"/>
<b>5.2 Carshare vehicles &amp; memberships</b>		
<i>Commuter travel</i>		
<b>BETTER</b>	5.2.1 Contract with provider to install on-site carshare vehicles and promote their use by tenants	<input checked="" type="checkbox"/>
<b>BETTER</b>	5.2.2 Provide employees with carshare memberships for local business travel	<input type="checkbox"/>
<b>6. PARKING</b>		
<b>6.1 Priced parking</b>		
<i>Commuter travel</i>		
<b>BASIC</b> ★	6.1.1 Charge for long-term parking (daily, weekly, monthly)	<input type="checkbox"/>
<b>BASIC</b>	6.1.2 Unbundle parking cost from lease rates at multi-tenant sites	<input checked="" type="checkbox"/>
<i>Visitor travel</i>		
<b>BETTER</b>	6.1.3 Charge for short-term parking (hourly)	<input checked="" type="checkbox"/>

TDM measures: Non-residential developments		Check if proposed & add descriptions
<b>7. TDM MARKETING &amp; COMMUNICATIONS</b>		
<b>7.1 Multimodal travel information</b>		
<i>Commuter travel</i>		
<b>BASIC</b> ★	7.1.1 Provide a multimodal travel option information package to new/relocating employees and students	<input checked="" type="checkbox"/>
<i>Visitor travel</i>		
<b>BETTER</b> ★	7.1.2 Include multimodal travel option information in invitations or advertising that attract visitors or customers (e.g. for festivals, concerts, games)	<input type="checkbox"/>
<b>7.2 Personalized trip planning</b>		
<i>Commuter travel</i>		
<b>BETTER</b> ★	7.2.1 Offer personalized trip planning to new/relocating employees	<input type="checkbox"/>
<b>7.3 Promotions</b>		
<i>Commuter travel</i>		
<b>BETTER</b>	7.3.1 Deliver promotions and incentives to maintain awareness, build understanding, and encourage trial of sustainable modes	<input type="checkbox"/>
<b>8. OTHER INCENTIVES &amp; AMENITIES</b>		
<b>8.1 Emergency ride home</b>		
<i>Commuter travel</i>		
<b>BETTER</b> ★	8.1.1 Provide emergency ride home service to non-driving commuters	<input type="checkbox"/>
<b>8.2 Alternative work arrangements</b>		
<i>Commuter travel</i>		
<b>BASIC</b> ★	8.2.1 Encourage flexible work hours	<input type="checkbox"/>
<b>BETTER</b>	8.2.2 Encourage compressed workweeks	<input type="checkbox"/>
<b>BETTER</b> ★	8.2.3 Encourage telework	<input type="checkbox"/>
<b>8.3 Local business travel options</b>		
<i>Commuter travel</i>		
<b>BASIC</b> ★	8.3.1 Provide local business travel options that minimize the need for employees to bring a personal car to work	<input type="checkbox"/>
<b>8.4 Commuter incentives</b>		
<i>Commuter travel</i>		
<b>BETTER</b>	8.4.1 Offer employees a taxable, mode-neutral commuting allowance	<input type="checkbox"/>
<b>8.5 On-site amenities</b>		
<i>Commuter travel</i>		
<b>BETTER</b>	8.5.1 Provide on-site amenities/services to minimize mid-day or mid-commute errands	<input type="checkbox"/>

**TDM Measures Checklist:**  
*Residential Developments (multi-family, condominium or subdivision)*

**Legend**

**BASIC** The measure is generally feasible and effective, and in most cases would benefit the development and its users

**BETTER** The measure could maximize support for users of sustainable modes, and optimize development performance

**\*** The measure is one of the most dependably effective tools to encourage the use of sustainable modes

TDM measures: Residential developments		Check if proposed & add descriptions
<b>1. TDM PROGRAM MANAGEMENT</b>		
<b>1.1 Program coordinator</b>		
BASIC	1.1.1 Designate an internal coordinator, or contract with an external coordinator	<input checked="" type="checkbox"/>
<b>1.2 Travel surveys</b>		
BETTER	1.2.1 Conduct periodic surveys to identify travel-related behaviours, attitudes, challenges and solutions, and to track progress	<input checked="" type="checkbox"/>
<b>2. WALKING AND CYCLING</b>		
<b>2.1 Information on walking/cycling routes &amp; destinations</b>		
BASIC	2.1.1 Display local area maps with walking/cycling access routes and key destinations at major entrances (multi-family, condominium)	<input checked="" type="checkbox"/>
<b>2.2 Bicycle skills training</b>		
BETTER	2.2.1 Offer on-site cycling courses for residents, or subsidize off-site courses	<input type="checkbox"/>

TDM measures: Residential developments		Check if proposed & add descriptions
<b>3. TRANSIT</b>		
<b>3.1 Transit information</b>		
BASIC	3.1.1 Display relevant transit schedules and route maps at entrances (multi-family, condominium)	<input checked="" type="checkbox"/>
BETTER	3.1.2 Provide real-time arrival information display at entrances (multi-family, condominium)	<input type="checkbox"/>
<b>3.2 Transit fare incentives</b>		
BASIC	3.2.1 Offer PRESTO cards preloaded with one monthly transit pass on residence purchase/move-in, to encourage residents to use transit	<input type="checkbox"/>
BETTER	3.2.2 Offer at least one year of free monthly transit passes on residence purchase/move-in	<input checked="" type="checkbox"/>
<b>3.3 Enhanced public transit service</b>		
BETTER	3.3.1 Contract with OC Transpo to provide early transit services until regular services are warranted by occupancy levels (subdivision)	<input type="checkbox"/>
<b>3.4 Private transit service</b>		
BETTER	3.4.1 Provide shuttle service for seniors homes or lifestyle communities (e.g. scheduled mall or supermarket runs)	<input type="checkbox"/>
<b>4. CARSHARING &amp; BIKESHARING</b>		
<b>4.1 Bikeshare stations &amp; memberships</b>		
BETTER	4.1.1 Contract with provider to install on-site bikeshare station (multi-family)	<input checked="" type="checkbox"/>
BETTER	4.1.2 Provide residents with bikeshare memberships, either free or subsidized (multi-family)	<input type="checkbox"/>
<b>4.2 Carshare vehicles &amp; memberships</b>		
BETTER	4.2.1 Contract with provider to install on-site carshare vehicles and promote their use by residents	<input checked="" type="checkbox"/>
BETTER	4.2.2 Provide residents with carshare memberships, either free or subsidized	<input type="checkbox"/>
<b>5. PARKING</b>		
<b>5.1 Priced parking</b>		
BASIC	5.1.1 Unbundle parking cost from purchase price (condominium)	<input checked="" type="checkbox"/>
BASIC	5.1.2 Unbundle parking cost from monthly rent (multi-family)	<input checked="" type="checkbox"/>

TDM measures: Residential developments		Check if proposed & add descriptions
<b>6. TDM MARKETING &amp; COMMUNICATIONS</b>		
<b>6.1 Multimodal travel information</b>		
BASIC ★	6.1.1 Provide a multimodal travel option package to new residents	<input type="checkbox"/>
<b>6.2 Personalized trip planning</b>		
BETTER ★	6.2.1 Offer personalized trip planning to new residents	<input type="checkbox"/>

**TDM-Supportive Development Design and Infrastructure Checklist: Non-Residential Developments (office, institutional, retail or industrial)**

**Legend**

**REQUIRED** The Official Plan or Zoning By-law provides related guidance that must be followed

**BASIC** The measure is generally feasible and effective, and in most cases would benefit the development and its users

**BETTER** The measure could maximize support for users of sustainable modes, and optimize development performance

TDM-supportive design & infrastructure measures: Non-residential developments		Check if completed & add descriptions, explanations or plan/drawing references
<b>1. WALKING &amp; CYCLING: ROUTES</b>		
<b>1.1 Building location &amp; access points</b>		
BASIC	1.1.1 Locate building close to the street, and do not locate parking areas between the street and building entrances	<input checked="" type="checkbox"/>
BASIC	1.1.2 Locate building entrances in order to minimize walking distances to sidewalks and transit stops/stations	<input checked="" type="checkbox"/>
BASIC	1.1.3 Locate building doors and windows to ensure visibility of pedestrians from the building, for their security and comfort	<input checked="" type="checkbox"/>
<b>1.2 Facilities for walking &amp; cycling</b>		
REQUIRED	1.2.1 Provide convenient, direct access to stations or major stops along rapid transit routes within 600 metres; minimize walking distances from buildings to rapid transit; provide pedestrian-friendly, weather-protected (where possible) environment between rapid transit accesses and building entrances; ensure quality linkages from sidewalks through building entrances to integrated stops/stations (see Official Plan policy 4.3.3)	<input checked="" type="checkbox"/>
REQUIRED	1.2.2 Provide safe, direct and attractive pedestrian access from public sidewalks to building entrances through such measures as: reducing distances between public sidewalks and major building entrances; providing walkways from public streets to major building entrances; within a site, providing walkways along the front of adjoining buildings; between adjacent buildings, and connecting areas where people may congregate, such as courtyards and transit stops; and providing weather protection through canopies, colonnades, and other design elements wherever possible (see Official Plan policy 4.3.12)	<input checked="" type="checkbox"/>

TDM-supportive design & infrastructure measures: Non-residential developments		Check if completed & add descriptions, explanations or plan/drawing references
REQUIRED	1.2.3 Provide sidewalks of smooth, well-drained walking surfaces of contrasting materials or treatments to differentiate pedestrian areas from vehicle areas, and provide marked pedestrian crosswalks at intersection sidewalks (see <i>Official Plan policy 4.3.10</i> )	<input checked="" type="checkbox"/>
REQUIRED	1.2.4 Make sidewalks and open space areas easily accessible through features such as gradual grade transition, depressed curbs at street corners and convenient access to extra-wide parking spaces and ramps (see <i>Official Plan policy 4.3.10</i> )	<input checked="" type="checkbox"/>
REQUIRED	1.2.5 Include adequately spaced inter-block/street cycling and pedestrian connections to facilitate travel by active transportation. Provide links to the existing or planned network of public sidewalks, multi-use pathways and on-road cycle routes. Where public sidewalks and multi-use pathways intersect with roads, consider providing traffic control devices to give priority to cyclists and pedestrians (see <i>Official Plan policy 4.3.11</i> )	<input checked="" type="checkbox"/>
BASIC	1.2.6 Provide safe, direct and attractive walking routes from building entrances to nearby transit stops	<input checked="" type="checkbox"/>
BASIC	1.2.7 Ensure that walking routes to transit stops are secure, visible, lighted, shaded and wind-protected wherever possible	<input checked="" type="checkbox"/>
BASIC	1.2.8 Design roads used for access or circulation by cyclists using a target operating speed of no more than 30 km/h, or provide a separated cycling facility	<input type="checkbox"/>
<b>1.3 Amenities for walking &amp; cycling</b>		
BASIC	1.3.1 Provide lighting, landscaping and benches along walking and cycling routes between building entrances and streets, sidewalks and trails	<input checked="" type="checkbox"/>
BASIC	1.3.2 Provide wayfinding signage for site access (where required, e.g. when multiple buildings or entrances exist) and egress (where warranted, such as when directions to reach transit stops/stations, trails or other common destinations are not obvious)	<input checked="" type="checkbox"/>

TDM-supportive design & infrastructure measures: Non-residential developments		Check if completed & add descriptions, explanations or plan/drawing references
<b>2. WALKING &amp; CYCLING: END-OF-TRIP FACILITIES</b>		
<b>2.1 Bicycle parking</b>		
REQUIRED	2.1.1 Provide bicycle parking in highly visible and lighted areas, sheltered from the weather wherever possible (see <i>Official Plan policy 4.3.6</i> )	<input checked="" type="checkbox"/>
REQUIRED	2.1.2 Provide the number of bicycle parking spaces specified for various land uses in different parts of Ottawa; provide convenient access to main entrances or well-used areas (see <i>Zoning By-law Section 111</i> )	<input checked="" type="checkbox"/>
REQUIRED	2.1.3 Ensure that bicycle parking spaces and access aisles meet minimum dimensions; that no more than 50% of spaces are vertical spaces; and that parking racks are securely anchored (see <i>Zoning By-law Section 111</i> )	<input type="checkbox"/>
BASIC	2.1.4 Provide bicycle parking spaces equivalent to the expected number of commuter cyclists (assuming the cycling mode share target is met), plus the expected peak number of customer/visitor cyclists	<input type="checkbox"/>
BETTER	2.1.5 Provide bicycle parking spaces equivalent to the expected number of commuter and customer/visitor cyclists, plus an additional buffer (e.g. 25 percent extra) to encourage other cyclists and ensure adequate capacity in peak cycling season	<input type="checkbox"/>
<b>2.2 Secure bicycle parking</b>		
REQUIRED	2.2.1 Where more than 50 bicycle parking spaces are provided for a single office building, locate at least 25% of spaces within a building/structure, a secure area (e.g. supervised parking lot or enclosure) or bicycle lockers (see <i>Zoning By-law Section 111</i> )	<input checked="" type="checkbox"/>
BETTER	2.2.2 Provide secure bicycle parking spaces equivalent to the expected number of commuter cyclists (assuming the cycling mode share target is met)	<input type="checkbox"/>
<b>2.3 Shower &amp; change facilities</b>		
BASIC	2.3.1 Provide shower and change facilities for the use of active commuters	<input type="checkbox"/>
BETTER	2.3.2 In addition to shower and change facilities, provide dedicated lockers, grooming stations, drying racks and laundry facilities for the use of active commuters	<input type="checkbox"/>
<b>2.4 Bicycle repair station</b>		
BETTER	2.4.1 Provide a permanent bike repair station, with commonly used tools and an air pump, adjacent to the main bicycle parking area (or secure bicycle parking area, if provided)	<input checked="" type="checkbox"/>

TDM-supportive design & infrastructure measures: Non-residential developments		Check if completed & add descriptions, explanations or plan/drawing references
<b>3. TRANSIT</b>		
<b>3.1 Customer amenities</b>		
BASIC	3.1.1 Provide shelters, lighting and benches at any on-site transit stops	<input type="checkbox"/>
BASIC	3.1.2 Where the site abuts an off-site transit stop and insufficient space exists for a transit shelter in the public right-of-way, protect land for a shelter and/or install a shelter	<input type="checkbox"/>
BETTER	3.1.3 Provide a secure and comfortable interior waiting area by integrating any on-site transit stops into the building	<input checked="" type="checkbox"/>
<b>4. RIDESHARING</b>		
<b>4.1 Pick-up &amp; drop-off facilities</b>		
BASIC	4.1.1 Provide a designated area for carpool drivers (plus taxis and ride-hailing services) to drop off or pick up passengers without using fire lanes or other no-stopping zones	<input type="checkbox"/>
<b>4.2 Carpool parking</b>		
BASIC	4.2.1 Provide signed parking spaces for carpools in a priority location close to a major building entrance, sufficient in number to accommodate the mode share target for carpools	<input type="checkbox"/>
BETTER	4.2.2 At large developments, provide spaces for carpools in a separate, access-controlled parking area to simplify enforcement	<input type="checkbox"/>
<b>5. CARSHARING &amp; BIKESHARING</b>		
<b>5.1 Carshare parking spaces</b>		
BETTER	5.1.1 Provide carshare parking spaces in permitted non-residential zones, occupying either required or provided parking spaces (see Zoning By-law Section 94)	<input checked="" type="checkbox"/>
<b>5.2 Bikeshare station location</b>		
BETTER	5.2.1 Provide a designated bikeshare station area near a major building entrance, preferably lighted and sheltered with a direct walkway connection	<input checked="" type="checkbox"/>

TDM-supportive design & infrastructure measures: Non-residential developments		Check if completed & add descriptions, explanations or plan/drawing references
<b>6. PARKING</b>		
<b>6.1 Number of parking spaces</b>		
REQUIRED	6.1.1 Do not provide more parking than permitted by zoning, nor less than required by zoning, unless a variance is being applied for	<input checked="" type="checkbox"/>
BASIC	6.1.2 Provide parking for long-term and short-term users that is consistent with mode share targets, considering the potential for visitors to use off-site public parking	<input type="checkbox"/>
BASIC	6.1.3 Where a site features more than one use, provide shared parking and reduce the cumulative number of parking spaces accordingly (see Zoning By-law Section 104)	<input checked="" type="checkbox"/>
BETTER	6.1.4 Reduce the minimum number of parking spaces required by zoning by one space for each 13 square metres of gross floor area provided as shower rooms, change rooms, locker rooms and other facilities for cyclists in conjunction with bicycle parking (see Zoning By-law Section 111)	<input type="checkbox"/>
<b>6.2 Separate long-term &amp; short-term parking areas</b>		
BETTER	6.2.1 Separate short-term and long-term parking areas using signage or physical barriers, to permit access controls and simplify enforcement (i.e. to discourage employees from parking in visitor spaces, and vice versa)	<input type="checkbox"/>
<b>7. OTHER</b>		
<b>7.1 On-site amenities to minimize off-site trips</b>		
BETTER	7.1.1 Provide on-site amenities to minimize mid-day or mid-commute errands	<input type="checkbox"/>

**TDM-Supportive Development Design and Infrastructure Checklist:  
Residential Developments (multi-family or condominium)**

Legend	
REQUIRED	The Official Plan or Zoning By-law provides related guidance that must be followed
BASIC	The measure is generally feasible and effective, and in most cases would benefit the development and its users
BETTER	The measure could maximize support for users of sustainable modes, and optimize development performance

TDM-supportive design & infrastructure measures: Residential developments		Check if completed & add descriptions, explanations or plan/drawing references
<b>1. WALKING &amp; CYCLING: ROUTES</b>		
<b>1.1 Building location &amp; access points</b>		
BASIC	1.1.1 Locate building close to the street, and do not locate parking areas between the street and building entrances	<input checked="" type="checkbox"/>
BASIC	1.1.2 Locate building entrances in order to minimize walking distances to sidewalks and transit stops/stations	<input checked="" type="checkbox"/>
BASIC	1.1.3 Locate building doors and windows to ensure visibility of pedestrians from the building, for their security and comfort	<input checked="" type="checkbox"/>
<b>1.2 Facilities for walking &amp; cycling</b>		
REQUIRED	1.2.1 Provide convenient, direct access to stations or major stops along rapid transit routes within 600 metres; minimize walking distances from buildings to rapid transit; provide pedestrian-friendly, weather-protected (where possible) environment between rapid transit accesses and building entrances; ensure quality linkages from sidewalks through building entrances to integrated stops/stations (see <i>Official Plan policy 4.3.3</i> )	<input checked="" type="checkbox"/>
REQUIRED	1.2.2 Provide safe, direct and attractive pedestrian access from public sidewalks to building entrances through such measures as: reducing distances between public sidewalks and major building entrances; providing walkways from public streets to major building entrances; within a site, providing walkways along the front of adjoining buildings, between adjacent buildings, and connecting areas where people may congregate, such as courtyards and transit stops; and providing weather protection through canopies, colonnades, and other design elements wherever possible (see <i>Official Plan policy 4.3.12</i> )	<input checked="" type="checkbox"/>

TDM-supportive design & infrastructure measures: Residential developments		Check if completed & add descriptions, explanations or plan/drawing references
REQUIRED	1.2.3 Provide sidewalks of smooth, well-drained walking surfaces of contrasting materials or treatments to differentiate pedestrian areas from vehicle areas, and provide marked pedestrian crosswalks at intersection sidewalks (see <i>Official Plan policy 4.3.10</i> )	<input checked="" type="checkbox"/>
REQUIRED	1.2.4 Make sidewalks and open space areas easily accessible through features such as gradual grade transition, depressed curbs at street corners and convenient access to extra-wide parking spaces and ramps (see <i>Official Plan policy 4.3.10</i> )	<input checked="" type="checkbox"/>
REQUIRED	1.2.5 Include adequately spaced inter-block/street cycling and pedestrian connections to facilitate travel by active transportation. Provide links to the existing or planned network of public sidewalks, multi-use pathways and on-road cycle routes. Where public sidewalks and multi-use pathways intersect with roads, consider providing traffic control devices to give priority to cyclists and pedestrians (see <i>Official Plan policy 4.3.11</i> )	<input checked="" type="checkbox"/>
BASIC	1.2.6 Provide safe, direct and attractive walking routes from building entrances to nearby transit stops	<input checked="" type="checkbox"/>
BASIC	1.2.7 Ensure that walking routes to transit stops are secure, visible, lighted, shaded and wind-protected wherever possible	<input checked="" type="checkbox"/>
BASIC	1.2.8 Design roads used for access or circulation by cyclists using a target operating speed of no more than 30 km/h, or provide a separated cycling facility	<input type="checkbox"/>
<b>1.3 Amenities for walking &amp; cycling</b>		
BASIC	1.3.1 Provide lighting, landscaping and benches along walking and cycling routes between building entrances and streets, sidewalks and trails	<input checked="" type="checkbox"/>
BASIC	1.3.2 Provide wayfinding signage for site access (where required, e.g. when multiple buildings or entrances exist) and egress (where warranted, such as when directions to reach transit stops/stations, trails or other common destinations are not obvious)	<input checked="" type="checkbox"/>

TDM-supportive design & infrastructure measures: Residential developments		Check if completed & add descriptions, explanations or plan/drawing references
<b>2. WALKING &amp; CYCLING: END-OF-TRIP FACILITIES</b>		
<b>2.1 Bicycle parking</b>		
<b>REQUIRED</b> 2.1.1	Provide bicycle parking in highly visible and lighted areas, sheltered from the weather wherever possible (see <i>Official Plan policy 4.3.6</i> )	<input checked="" type="checkbox"/>
<b>REQUIRED</b> 2.1.2	Provide the number of bicycle parking spaces specified for various land uses in different parts of Ottawa; provide convenient access to main entrances or well-used areas (see <i>Zoning By-law Section 111</i> )	<input checked="" type="checkbox"/>
<b>REQUIRED</b> 2.1.3	Ensure that bicycle parking spaces and access aisles meet minimum dimensions, that no more than 50% of spaces are vertical spaces, and that parking racks are securely anchored (see <i>Zoning By-law Section 111</i> )	<input type="checkbox"/>
<b>BASIC</b> 2.1.4	Provide bicycle parking spaces equivalent to the expected number of resident-owned bicycles, plus the expected peak number of visitor cyclists	<input type="checkbox"/>
<b>REQUIRED</b> 2.2	<b>Secure bicycle parking</b>	
<b>REQUIRED</b> 2.2.1	Where more than 50 bicycle parking spaces are provided for a single residential building, locate at least 25% of spaces within a building/structure, a secure area (e.g. supervised parking lot or enclosure) or bicycle lockers (see <i>Zoning By-law Section 111</i> )	<input checked="" type="checkbox"/>
<b>BETTER</b> 2.2.2	Provide secure bicycle parking spaces equivalent to at least the number of units at condominiums or multi-family residential developments	<input type="checkbox"/>
<b>BETTER</b> 2.3	<b>Bicycle repair station</b>	
<b>BETTER</b> 2.3.1	Provide a permanent bike repair station, with commonly used tools and an air pump, adjacent to the main bicycle parking area (or secure bicycle parking area, if provided)	<input checked="" type="checkbox"/>
<b>3. TRANSIT</b>		
<b>3.1 Customer amenities</b>		
<b>BASIC</b> 3.1.1	Provide shelters, lighting and benches at any on-site transit stops	<input type="checkbox"/>
<b>BASIC</b> 3.1.2	Where the site abuts an off-site transit stop and insufficient space exists for a transit shelter in the public right-of-way, protect land for a shelter and/or install a shelter	<input type="checkbox"/>
<b>BETTER</b> 3.1.3	Provide a secure and comfortable interior waiting area by integrating any on-site transit stops into the building	<input checked="" type="checkbox"/>

TDM-supportive design & infrastructure measures: Residential developments		Check if completed & add descriptions, explanations or plan/drawing references
<b>4. RIDESHARING</b>		
<b>4.1 Pick-up &amp; drop-off facilities</b>		
<b>BASIC</b> 4.1.1	Provide a designated area for carpool drivers (plus taxis and ride-hailing services) to drop off or pick up passengers without using fire lanes or other no-stopping zones	<input type="checkbox"/>
<b>5. CARSHARING &amp; BIKESHARING</b>		
<b>5.1 Carshare parking spaces</b>		
<b>BETTER</b> 5.1.1	Provide up to three carshare parking spaces in an R3, R4 or RS Zone for specified residential uses (see <i>Zoning By-law Section 94</i> )	<input type="checkbox"/>
<b>BETTER</b> 5.2	<b>Bikeshare station location</b>	
<b>BETTER</b> 5.2.1	Provide a designated bikeshare station area near a major building entrance, preferably lighted and sheltered with a direct walkway connection	<input checked="" type="checkbox"/>
<b>6. PARKING</b>		
<b>REQUIRED</b> 6.1	<b>Number of parking spaces</b>	
<b>REQUIRED</b> 6.1.1	Do not provide more parking than permitted by zoning, nor less than required by zoning, unless a variance is being applied for	<input checked="" type="checkbox"/>
<b>BASIC</b> 6.1.2	Provide parking for long-term and short-term users that is consistent with mode share targets, considering the potential for visitors to use off-site public parking	<input type="checkbox"/>
<b>BASIC</b> 6.1.3	Where a site features more than one use, provide shared parking and reduce the cumulative number of parking spaces accordingly (see <i>Zoning By-law Section 104</i> )	<input checked="" type="checkbox"/>
<b>BETTER</b> 6.1.4	Reduce the minimum number of parking spaces required by zoning by one space for each 13 square metres of gross floor area provided as shower rooms, change rooms, locker rooms and other facilities for cyclists in conjunction with bicycle parking (see <i>Zoning By-law Section 111</i> )	<input type="checkbox"/>
<b>BETTER</b> 6.2	<b>Separate long-term &amp; short-term parking areas</b>	
<b>BETTER</b> 6.2.1	Provide separate areas for short-term and long-term parking (using signage or physical barriers) to permit access controls and simplify enforcement (i.e. to discourage residents from parking in visitor spaces, and vice versa)	<input type="checkbox"/>

# Appendix H

Signal Warrant – OTM Justification 7

Gladstone Ave @ Loretta Ave N  
 Future Total

**Justification #7**

Justification	Description	Minimum Requirement		Minimum Requirement		Compliance			Signal
		1 Lane Highway		2 or More Lanes		Numerical	Sectional	Entire %	
		Free Flow	Restr. Flow	Free Flow	Restr. Flow				
1. Minimum Vehicular Volume	A. Vehicle volume, all approaches (average hour)	480	720	600	900	413	57%	34%	No
	B. Vehicle volume, along minor streets (average hour)	120	170	120	170	57	34%		
2. Delay to Cross Traffic	A. Vehicle volumes, major street (average hour)	480	720	600	900	356	49%	42%	No
	B. Combined vehicle and pedestrian volume crossing artery from minor streets (average hour)	50	75	50	75	32	42%		

Notes

1. Refer to OTM Book 12, pg 92, Mar 2012
2. Lowest section percentage governs justification
3. Average hourly volumes estimated from peak hour volumes,  $AHV = PM/2$  or  $(AM + PM) / 4$ , including amplification factors
4. T-intersection factor corrected, applies only to 1B