



# Site Servicing and Stormwater Management Report

## Riverside South School Rev 1

Brian Good and Solarium Avenue, Ottawa, Ontario



Prepared for



City of Ottawa  
Infrastructure Services and Community Sustainability  
110 Laurier Ave. West, 4th floor, Mail Code 01-14  
Ottawa, Ontario, K1P 1J1



## Rev 1 SUBMISSION Oct 10, 2022

---

### Table of Contents

1	Introduction .....	3
1.1	Design Drawings .....	3
2	Objective .....	3
3	<b>Stormwater Management</b> .....	3
3.1	Pre-Development Conditions .....	3
3.2	Allowable Release Rate .....	3
3.3	Post-Development Conditions .....	4
3.4	Storm Sewer Pipe Design .....	4
3.5	Stormwater Quality Control .....	4
3.6	Stormwater Quantity Control .....	4
4	<b>Sanitary Servicing</b> .....	5
5	<b>Water</b> .....	5
5.1	Domestic Water Demand .....	5
5.2	Fire Flow Demand .....	6
❖	<b>Appendix A</b>	<b>Drawings and Figures</b>
❖	<b>Appendix B</b>	<b>Stormwater Management Calculations</b>
❖	<b>Appendix C</b>	<b>Sanitary Servicing Calculations</b>
❖	<b>Appendix D</b>	<b>Fire Flow Demand Calculations</b>
❖	<b>Appendix E</b>	<b>Pre-Consultation &amp; Development Servicing Study Checklist</b>
❖	<b>Appendix F</b>	<b>Roof Drain and ICD Product Data Sheets</b>
❖	<b>Appendix G</b>	<b>Boundary Conditions &amp; Pressure check (pending)</b>
❖	<b>Appendix H</b>	<b>Subdivision Documents</b>

---

# 1 Introduction

Jp2g Consultants Inc. was retained by PRTY Architects Inc. to complete a Site Servicing and Stormwater Management Report suitable for the City of Ottawa Site Plan Control Application, for the Ottawa Catholic School Board development located at the southeast corner of Brian Good and Solarium Avenue intersection Ottawa, ON.

The site is approximately **2.74 ha** in size and is bound by Briand Good and Solarium Avenue on the east and south property limits respectively. The proposed development includes the construction of a new one-storey school with no basement, and associated parking and landscaped areas. The roof area is approximately **4,721 m<sup>2</sup>**.

A Pre-Consultation meeting was held with City of Ottawa staff on July 25, 2022, to determine the project constraints and requirements. The following report details the site servicing & stormwater management calculations used for capacity, water quantity and quality control in accordance with the City of Ottawa's requirements.

## 1.1 Design Drawings

The following reference civil design drawings are included.

- C1 – Site Servicing Plan
- C2 – Site Grading, Erosion and Sedimentation Control
- C3 – Details
- Figure 1 – Pre-Development Storm Drainage Areas
- Figure 2 – Post-Development Storm Drainage Areas
- Figure 3 – Fire Hydrant Coverage Area

## 2 Objective

This study will outline the servicing requirements for the development and identify the impact of the development on the existing municipal services, including water, storm and sanitary.

The stormwater management plan is to control post-development peak flows to pre-determined levels, and detain onsite, stormwater up to and including the 100-year storm event with a 20% increase of rainfall intensity without affecting adjacent lands, and to provide clean runoff to minimize pollution of the downstream receiving watercourse.

## 3 Stormwater Management

### 3.1 Pre-Development Conditions

The existing site is in an undeveloped parcel bounded by residential developments to the east, south, and west, and a park to the north. A **2400mm** storm sewer at **0.18%** slope is constructed by others on Solarium Avenue at the south side of the site.

### 3.2 Allowable Release Rate

The stormwater management design criteria for this site are based on the IBI's storm drainage plan for design brief River's Edge at Riverside South - Phase 1 dated June 2020. According to the storm drainage plan see PDF page 143 for storm area drawing 501 of IBI report). A post-development allowable release rate of **Q<sub>allowable</sub> = 410 l/s** was determined, using a predevelopment runoff coefficient of 0.7, and the 2-year storm intensity, see attached **Appendix B**.



### 3.3 Post-Development Conditions

The proposed site development includes a new school building, asphalt parking, hard surface walkways and landscaped areas. Site storm drainage will be conveyed to the existing 2400mm dia. storm sewer on Solarium Avenue. The storm water will be managed to limit the 100-year post-development flow rate to the pre-allocated release rate identified in section 3.2.

The site development area is approximately 2.74 ha with a post-development average weighted run-off coefficient of **C = 0.40** and **C = 0.47** for the 5-year and 100-year storm events, respectively. Refer to calculations in **Appendix B**. Stormwater management techniques are required to reduce peak flows from the area, given that post-development peak flows will exceed the pre-allocated allowable release rate of **410 l/s**.

### 3.4 Storm Sewer Pipe Design

Pipe diameter sizing was based on the **5-year** storm event, in accordance with City requirements. Under 5-year conditions, the storm sewers are not in surcharged conditions (i.e., flow/capacity <100%).

### 3.5 Stormwater Quality Control

Based on the pre-consultation meeting and communication with the Rideau Valley Conservation Authority, no additional stormwater quality control is required for this site. We understand that the existing storm sewer system is treated downstream for quality control by the Riverside South Stormwater Management Ponds to an enhanced level of service (80% TSS removal).

### 3.6 Stormwater Quantity Control

Post-development peak flows will be controlled on the building's roof, in the proposed parking area and in the school yard by installing flow restrictors at the outlet of storm structures CB-1, CB-2, CB-3, and CBMH-3, limiting the outlet discharge for all structures as follows:

**Table 1: Allowable Release Rate Breakdown**

ID	Description	Flows	
		5-Year Event	100-Year Event
	Allowable Release Rate (Section 3.2)	<b>410 L/s</b>	<b>410 L/s</b>
1.2.1	Uncontrolled overland surface flow	<b>29.3 L/s</b>	<b>59.29 L/s</b>
1.2.2	Uncontrolled Network Flow	<b>81.4 L/s</b>	<b>155.4 L/s</b>
1.2.3	Controlled Network Allowable Release Rate	<b>299.3 L/s</b>	<b>195.3 L/s*</b>
1.2.3.4	Total Network Allowable Flow	<b>276.5 L/s</b>	<b>350.6 L/s</b>

\* Note: Must be controlled to net-allowable 100-year.



**Table 2: Actual Release Rate Breakdown**

ID	Description	Flows	
		5-Year Event	100-Year Event
	Allowable Release Rate (Section 3.2)	410 L/s	410 L/s
1.2.1	Uncontrolled overland surface flow	29.3 L/s	59.3 L/s
1.2.2	Uncontrolled Network Flow	81.4 L/s	155.4 L/s
1.2.3	Controlled Network Release Rate	193.9 L/s	193.9 L/s
1.2.4	Summation of Released Flows	304.3 L/s	408.6 L/s

Site runoff is contributed from two components: uncontrolled watersheds releasing directly off the site overland, and the storm sewer network releasing flows into the 2400mm dia. On Solarium Avenue. The storm system comprises of controlled watersheds with ICDs at the inlet of catch basins, and two uncontrolled watersheds at CBMH-2 and CBMH-1. To meet the site's allowable release rate, the controlled watershed flows were restricted to the stringent requirement, 195.1 L/s, as shown in table 1. In this manner, the actual release rates for the 5 year, and 100 year storms were 304.6 L/s and 408.6 L/s respectively, exceeding the 410 L/s requirement.

The maximum ponding depth in parking lots will be less than 350mm for the 100-year + 20% event. The maximum ponding limits generated from the ICD's are indicated on drawing **C2 – Grading Plan**. In the event the capacity of this system is exceeded, emergency runoff will overflow onto Solarium Avenue from the parking lot entrance as shown on drawing **C2**. Flow will also be detained on the school roof by installing parabolic weirs, (Watts Drainage Adjustable Flow Control for Roof Drains, or equivalent approved product), at the 21 proposed roof drains limiting the total flow from the roof to **39.69 L/s**. Each flow control roof drain will restrict flow to **1.89 L/s** Refer to **Appendix G product data sheets**.

## 4 Sanitary Servicing

A new **200mm** sanitary sewer will connect to the existing **200mm** sanitary sewer on Solarium Avenue. Sanitary sewers at 1.0% slope will convey the sanitary flows through the site, where a 5.6% last segment of sewer will connect the school's sanitary system to the existing sanitary manhole **MH505A** on Solarium Avenue. Refer to drawing **C1 – Site Servicing Plan**.

Peak sanitary flow for the site is calculated to be **2.24 l/s**. The new **200mm** sanitary sewers at **1.0%** slope will have a full flow capacity of **32.8 l/s**. The peak flows for the site are within the allocated sanitary flows based on IBI's sanitary sewer design sheet in Appendix C of Design Brief, Rivers Edge Phase 1 Riverside South Community. The full flow capacities indicate it is sufficient to handle the new development sanitary flows. The sanitary demand was calculated based on the *City of Ottawa Sewer Design Guidelines 2012* and *Technical Bulletins 2018*. Refer to **Appendix C** for full calculations.

## 5 Water

The school facility requires more than 50 m<sup>3</sup> per day, therefore twining of the water connection is proposed from the existing 300mm watermain on Brian Good Avenue to supply the building and the future private fire hydrant on site.

### 5.1 Domestic Water Demand

The water demand for the new school is calculated based on Table 4.2 of the *City of Ottawa Design Guidelines for Water Distribution*.



### **Design Criteria:**

The total population for the subject school is 1024 persons, including all students and staff in the main building and portables.

- Average daily demand for schools = 70 l/student/day
- Maximum school occupancy = 1,024 persons (staff and students)
- Maximum Day Factor (Institutional) = 1.5
- Maximum Hour Factor (Institutional) = 1.8

Average Daily Demand:  $\frac{70 \text{ l/student/day} \times 1024 \text{ population}}{24 \text{ hrs/day} \times 3600 \text{ s/hr}} = 0.83 \text{ l/s}$  (71.68 m<sup>3</sup> per day)

Maximum Daily Demand:  $0.83 \text{ l/s} \times 1.5 = 1.25 \text{ l/s}$

Maximum Hour Demand:  $1.25 \text{ l/s} \times 1.8 = 2.25 \text{ l/s}$

## **5.2 Fire Flow Demand**

There are four (4) fire hydrants along the frontage of the property and a proposed future private fire hydrant which will provide fire protection to the site (building and future portables). Two (2) along Solarium Avenue and another two (2) along Brian Good Avenue. The new building will be equipped with an automatic sprinkler system. Based on the Fire Underwriters Survey Method 2020, the fire flow demand for the new school is calculated to be:

Fire Flow Demand: **100.0 l/s** (Refer to Appendix D – Fire Flow Calculations).

---

Prepared By:



Ali Sammour, M.Eng., P.Eng., PMP  
Manager Civil Engineering  
Jp2g Consultants Inc.  
Email: [alis@jp2g.com](mailto:alis@jp2g.com)  
613 828 7800  
1150 Morrison Drive, Suite 410 Ottawa, Ontario, K2H 8S9



## **Appendix A - Drawings and Figures**

**LEGEND**

- PROPERTY LINE
- EXISTING BUILDING
- DEPRESSED CURB
- BREAK OF SLOPE - NEW
- NEW FENCE
- EXISTING SANITARY SEWER
- EXISTING STORM SEWER
- EXISTING WATERMAIN
- NEW SANITARY SEWER
- NEW STORM SEWER
- NEW WATERMAIN
- NEW SILT FENCE
- SWALE
- BERM
- NEW LIGHT DUTY ASPHALT
- NEW HEAVY DUTY ASPHALT
- NEW CONCRETE SIDEWALK
- NEW GRASS
- NEW REINFORCED GRASS
- NEW INSULATION
- MILLING & OVERLAY 50mm THICK
- HEAVY DUTY ASPHALT AS PER CITY SPECS
- NEW GRAVEL
- NEW MULCH
- SEE SHEET NUMBER "CS"
- EX-CB EXISTING CATCHBASIN
- EX-MH EXISTING MANHOLES
- CB-# NEW CATCHBASIN
- CBMH-# NEW CATCHBASIN MANHOLE
- SAMH-# NEW SANITARY MANHOLE
- STMH-# NEW STORM MANHOLE
- WV NEW WATER VALVE
- NI NEW INLET CONTROL DEVICE
- RD NEW ROOF DRAIN
- SC NEW SCUPPER
- NEW SIAMESE CONNECTION

- GENERAL NOTES**
- DESIGN AND CONSTRUCTION IS TO BE IN ACCORDANCE WITH MOST RECENT ONTARIO BUILDING CODE.
  - THE CONTRACTOR IS RESPONSIBLE FOR CHECKING AND VERIFYING ALL DIMENSIONS WITH RESPECT TO SITE CONDITIONS AND ALL MATERIALS TO THE PROJECT. ANY DISCREPANCY SHALL BE REPORTED TO THE ENGINEER.
  - THIS DRAWING IS TO BE READ IN CONJUNCTION WITH ALL MATERIAL RELEVANT TO THE PROJECT.
  - ADDITIONAL DRAWINGS MAY BE ISSUED FOR CLARIFICATION TO ASSIST PROPER EXECUTION OF WORK. SUCH DRAWINGS WILL HAVE THE SAME MEANING AND INTENT AS IF THEY WERE INCLUDED WITH THE CONTRACT DOCUMENTS.
  - CONTRACTOR MUST COMPLY WITH LOCAL BY-LAWS, ONTARIO OCCUPATIONAL HEALTH AND SAFETY ACT AND ALL REGULATIONS SET BY AUTHORITIES HAVING JURISDICTION. IN CASE OF CONFLICT OR DISCREPANCY, THE MORE STRINGENT REQUIREMENTS SHALL APPLY.
  - CONTRACTOR RESPONSIBLE FOR OBTAINING ALL REQUIRED UTILITY LOCATES, DAYLIGHTING, INSPECTIONS, PERMITS, AND APPROVALS INCLUDING ALL ASSOCIATED COSTS. LOCATION OF EXISTING UTILITIES ARE APPROXIMATE ONLY AND BASED ON BEST AVAILABLE INFORMATION.

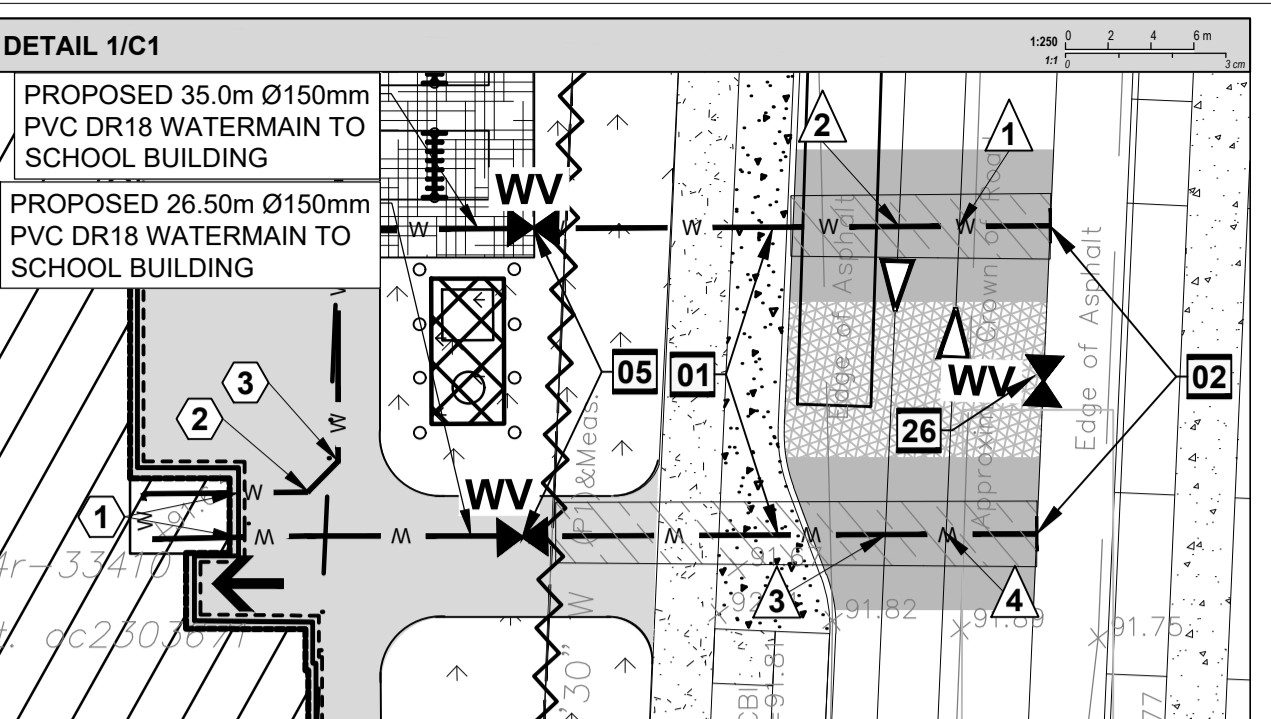

**DRAWING NOTES**

- SUPPLY AND INSTALL NEW 2x150mm Ø PVC DR18 WATER MAIN SERVICE, MINIMUM 2.4m COVER, OTHERWISE PROVIDE H40 THERMAL INSULATION IN ACCORDANCE WITH CITY OF OTTAWA STANDARD DETAIL DRAWING W22. CONTRACTOR SHALL BE RESPONSIBLE FOR OBTAINING AND PAYING FOR A WATER PERMIT FROM THE CITY OF OTTAWA FOR INSPECTION, DISINFECTION (CHLORINATION) AND TESTING. COORDINATE NEW WATER SERVICE CONNECTION WITH MECHANICAL PLANS.
- INSTALLATION OF NEW SERVICE CONNECTION TEE 2x150mm Ø PVC TO EXISTING MUNICIPAL WATERMAIN TO BE COMPLETED BY CITY OF OTTAWA FORCES. EXCAVATION, BACKFILL AND RE-INSTATEMENT BY CONTRACTOR.
- CONTRACTOR TO CONFIRM INVERT LEVEL IN EXISTING SANITARY MANHOLE.
- INSTALL FOUR WAY 3.0m LONG 100mm Ø PERFORATED SUBDRAIN WRAPPED IN GEOTEXTILE SOCK EXTENDING FROM CB/CBMH AT PAVEMENT SUBGRADE LEVEL. PROVIDE WATER TIGHT CONNECTION.
- SUPPLY AND INSTALL NEW 150mm WATER VALVE AT PROPERTY LINE. VALVEBOX ASSEMBLY AS PER CITY OF OTTAWA STANDARD DETAIL DRAWING W24 AND W50.
- SUPPLY AND INSTALL WATTS ROOF DRAIN CONTROLS TO BE INSTALLED ON ROOF DRAINS. MAXIMUM DISCHARGE 38.69 l/s TOTAL. MAXIMUM ROOF PONDING DEPTH 0.15m. REFER TO MECHANICAL FOR SPECIFIC WEIR SETTINGS. 5 YEAR PONDING VOLUME: 53m³, 100 YEAR PONDING VOLUME: 146m³.
- NEW TRANSFORMER AND BOLLARDS.
- SUPPLY AND INSTALL NEW INLET CONTROL DEVICE FLOW REGULATOR AT CATCHBASIN MANHOLE. CBMH-3 OUTLET. MAXIMUM DISCHARGE 86.40 l/s AT 2.16m HEAD AND ORIFICE DIAMETER AT 160mm.
- SUPPLY AND INSTALL NEW INLET CONTROL DEVICE FLOW REGULATOR AT CATCHBASIN. CB-1 OUTLET. MAXIMUM DISCHARGE 33.00 l/s AT 1.10m HEAD AND ORIFICE DIAMETER AT 122mm.
- CONTRACTOR TO CONFIRM INVERT LEVEL IN EXISTING STORM SEWER.
- INSTALL NEW MONITORING STORM MANHOLE. STMH-1 AND 450mm Ø STORM SEWER PIPE TO CONNECT THE EXISTING 2400mm STORM SEWER.
- INSTALL NEW MONITORING SANITARY MANHOLE SAMH-1 AND 200mm Ø SANITARY SEWER PIPE TO CONNECT THE EXISTING SANITARY MANHOLE.
- PROVIDE 100mm HIGH LOAD RIGID INSULATION PLACED WITHIN SUBGRADE. INSULATION SHALL BE 2.0m WIDE ABOVE PIPE WHERE INDICATED.
- CONNECT STORM SEWER TO BUILDING AT INVERT 90.35.
- CONNECT SANITARY SEWER TO BUILDING AT INVERT 90.35.
- NEW PERIMETER FOUNDATION DRAINAGE (REFER TO ARCHITECTURAL) TO BE CONNECTED TO THE NEW STORM SEWER.
- EDGE BERM.
- SUPPLY AND INSTALL NEW 250mm Ø PERFORATED DRAIN PIPE c/w FILTER SOCK AS PER CITY DETAIL S9. CONNECT SUBDRAIN TO CBMH-3. PROVIDE WATER TIGHT CONNECTION.
- ALL WATERMAIN SHALL BE PROVIDED WITH TRACER WIRE AS PER CITY OF OTTAWA STANDARD DETAILS AND SPECIFICATIONS.
- INSTALL UNDERGROUND CAP WITH METAL BOX FOR CONNECTION TO THE FUTURE FIRE HYDRANT VALVE.
- NEW SIAMESE CONNECTION.
- SUPPLY AND INSTALL BACKFLOW VALVES ON SANITARY AND STORM BUILDING CONNECTION AS PER CITY OF OTTAWA REQUIREMENT. CONTRACTOR TO PROVIDE SHOP DRAWINGS FOR PROPLEX PROCO 790 DUCK BILL TYPE AS FOLLOWS:
  - SANITARY BACKWATER VALVE, 8" SIZE (200mm).
  - STORM BACKWATER VALVE, 12" SIZE (300mm).
  - VALVE CLAMP LOCATIONS AT DISCHARGE.
- SUPPLY AND INSTALL NEW INLET CONTROL DEVICE FLOW REGULATOR AT CATCHBASIN. CBM-3 OUTLET. MAXIMUM DISCHARGE 16.40 l/s AT 1.12m HEAD AND ORIFICE DIAMETER AT 85mm.
- SUPPLY AND INSTALL NEW INLET CONTROL DEVICE FLOW REGULATOR AT CATCHBASIN. CB-3 OUTLET. MAXIMUM DISCHARGE 18.40 l/s AT 1.16m HEAD AND ORIFICE DIAMETER AT 90mm.
- SUBDRAINS SHOULD BE INSTALLED ON THE SIDES OF THE ACCESS ROAD AND PARKING AREA. SEE GEOTECHNICAL NOTES AND REFER TO GEOTECHNICAL REPORT.
- SUPPLY AND INSTALL NEW 300mm WATER VALVE AS PER CITY OF OTTAWA STANDARD DETAILS.

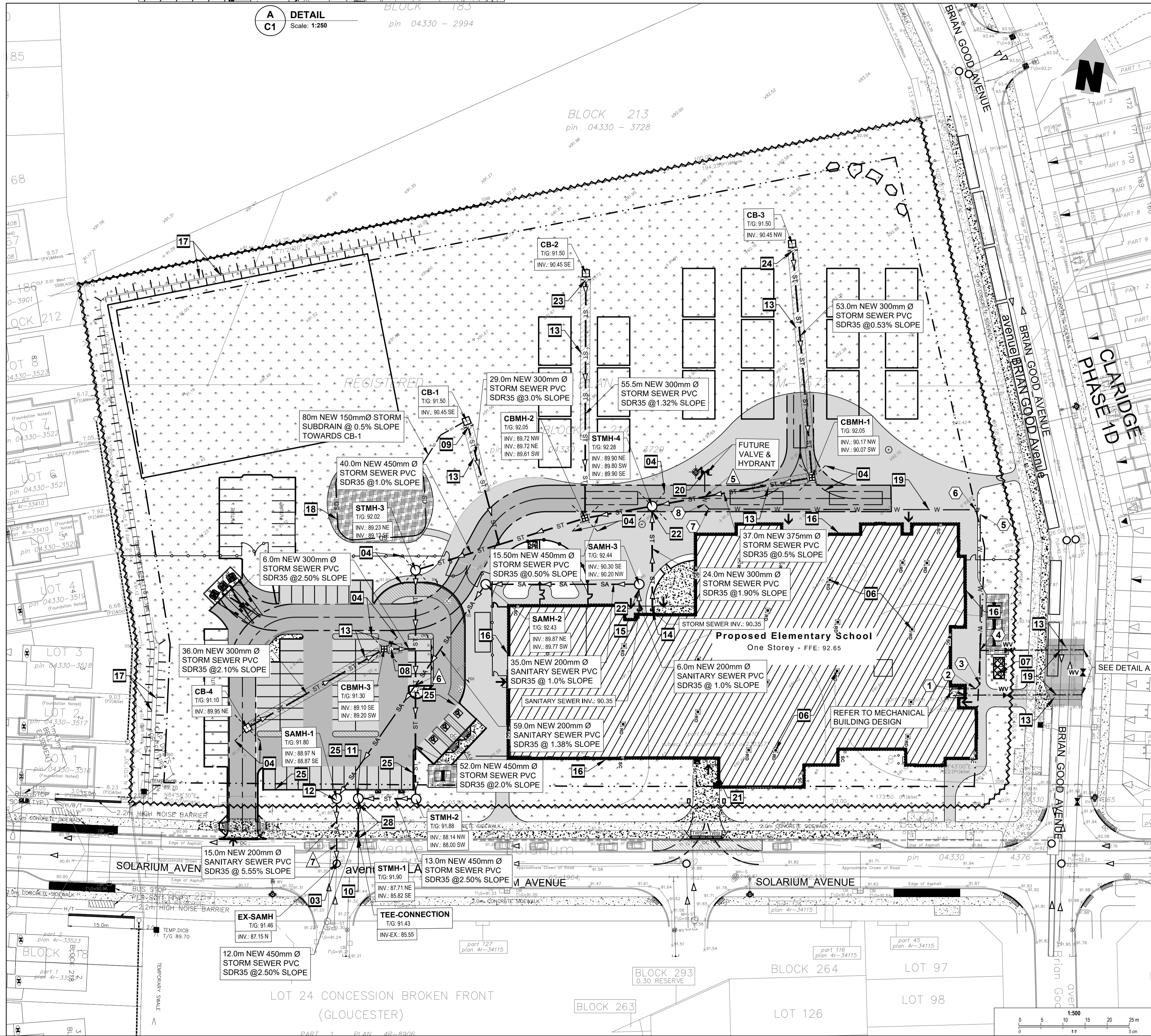

**Jp2g Consultants Inc.**  
 ENGINEERS - PLANNERS - PROJECT MANAGERS  
 1150 Morrison Drive, Suite 410, Ottawa, ONT.  
 Phone: (613) 828-7800 Fax: (613) 828-2900  
 Jp2g No.: 20-1095D



1	ISSUED FOR SITE PLAN CONTROL REV-1	2022-10-10
No.	Description	YYYY-MM-DD



Client: **P R PYE & RICHARDS - TEMPRANO & YOUNG ARCHITECTS INC.**  
 824 Meath St. Suite 200 613.724.7700  
 Ottawa, ON K1Z 6E8 info@prty.ca

Project: **OCSB Riverside South Elementary School**  
 Solarium & Brian Good, Ottawa, Ontario

Drawing Title: **Site Servicing Plan**

Do not scale. Refer any dimensional errors and/or possible trade interference/conflict to the architect for clarification prior to commencement of the work. The conditions of the contract apply.

Project No.	Drawing No.
Scale: <b>As shown</b>	<b>C1</b>
Drawn By: <b>R.I.</b>	
Checked: <b>A.S.</b>	
Date	Revision No.



LEGEND	
	PROPERTY LINE
	EXISTING BUILDING
	BREAK OF SLOPE - NEW
	NEW FENCE
	EXISTING SANITARY SEWER
	EXISTING STORM SEWER
	EXISTING WATERMAIN
	NEW SANITARY SEWER
	NEW STORM SEWER
	NEW WATERMAIN
	SWALE
	BERM
	NEW LIGHT DUTY ASPHALT
	NEW HEAVY DUTY ASPHALT
	NEW CONCRETE SIDEWALK
	NEW GRASS
	NEW REINFORCED GRASS
	MILLING & OVERLAY 50mm THICK HEAVY DUTY ASPHALT AS PER CITY SPECS
	NEW GRAVEL
	NEW MULCH
	NEW SILT FENCE
	DEPRESSED CURB
	EXISTING CATCHBASIN
	EXISTING MANHOLES
	NEW CATCHBASIN
	NEW CATCHBASIN MANHOLE
	NEW SANITARY MANHOLE
	NEW STORM MANHOLE
	NEW WATER VALVE
	NEW TRANSFORMER PAD
	EXISTING GRADE
	NEW GRADE
	NEW SLOPE
	OVERLAND FLOW ROUTE
	TOP OF CURB
	BOTTOM OF CURB
	NEW SIAMSESE CONNECTION

- ### GENERAL NOTES
- DESIGN AND CONSTRUCTION IS TO BE IN ACCORDANCE WITH MOST RECENT ONTARIO BUILDING CODE.
  - THE CONTRACTOR IS RESPONSIBLE FOR CHECKING AND VERIFYING ALL DIMENSIONS WITH RESPECT TO SITE CONDITIONS AND ALL MATERIALS TO THE PROJECT. ANY DISCREPANCY SHALL BE REPORTED TO THE ENGINEER.
  - THIS DRAWING IS TO BE READ IN CONJUNCTION WITH ALL MATERIAL RELEVANT TO THE PROJECT.
  - ADDITIONAL DRAWINGS MAY BE ISSUED FOR CLARIFICATION TO ASSIST PROPER EXECUTION OF WORK. SUCH DRAWINGS WILL HAVE THE SAME MEANING AND INTENT AS IF THEY WERE INCLUDED WITH THE CONTRACT DOCUMENTS.
  - CONTRACTOR MUST COMPLY WITH LOCAL BY-LAWS, ONTARIO OCCUPATIONAL HEALTH AND SAFETY ACT AND ALL REGULATIONS SET BY AUTHORITIES HAVING JURISDICTION. IN CASE OF CONFLICT OR DISCREPANCY, THE MORE STRINGENT REQUIREMENTS SHALL APPLY.
  - CONTRACTOR RESPONSIBLE FOR OBTAINING ALL REQUIRED UTILITY LOCATES, DAYLIGHTING, INSPECTIONS, PERMITS, AND APPROVALS, INCLUDING ALL ASSOCIATED COSTS. LOCATION OF EXISTING UTILITIES ARE APPROXIMATE ONLY AND BASED ON BEST AVAILABLE INFORMATION.

- ### DRAWING NOTES
- INSTALL SILT FENCE IN ACCORDANCE WITH OPSD 219.130.
  - MATCH EXISTING GRADES AT PROPERTY LINE AND LIMITS OF WORK.
  - INSTALL HEAVY DUTY PAVEMENT IN ACCORDANCE WITH DETAIL 2/3 ACCORDINGLY. REINSTATE GRADES TO THE INTO EXISTING AND PROVIDE POSITIVE DRAINAGE TOWARDS STORM STRUCTURES.
  - INSTALL LIGHT DUTY PAVEMENT IN ACCORDANCE WITH DETAIL 1/3 ACCORDINGLY. REINSTATE GRADES TO THE INTO EXISTING AND PROVIDE POSITIVE DRAINAGE TOWARDS STORM STRUCTURES.
  - GRADES TO SLOPE AWAY FROM THE BUILDING TO PROVIDE POSITIVE DRAINAGE.
  - ANY DISTURBED AREA WITHIN THE RIGHT-OF-WAY SHALL BE REINSTATED TO EQUAL OR BETTER CONDITION TO THE SATISFACTION OF THE CITY OF OTTAWA.
  - PROTECT EXISTING MANHOLES AND CATCHBASINS USING A FILTER SOCK OR FILTER BASE IN ACCORDANCE WITH DETAIL 4/3.
  - CONSTRUCT ENTRANCE IN ACCORDANCE WITH CITY OF OTTAWA STANDARD DETAIL DRAWING SC7.1 - CURB RETURN ENTRANCES.
  - PAVEMENT TO BE WITHIN 12mm OF DOOR.
  - PROVIDE MAXIMUM 4:1 SLOPE.
  - NEW EXTENSION OF EXISTING SIDEWALK MAINTAIN EXISTING BARRIER CURB. PROVIDE DOWELS AND JOINTS BETWEEN EXISTING AND NEW SIDEWALK EXTENSION AS APPLICABLE PER CITY OF OTTAWA STANDARD DETAILS R4, R5 AND R6. CONTRACTOR SHALL ENSURE THE STRUCTURAL INTEGRITY OF EXISTING CONCRETE SIDEWALK AND EXISTING CURB BARRIER THAT WILL REMAIN IN PLACE AND ITS UNDERLYING GRANULAR BASE WHEN COMPACTING THE SUBGRADE AND GRANULAR BASE OF THE NEW SIDEWALK EXTENSION.
  - CONTRACTOR TO PROVIDE TRENCH BOX FOR EXCAVATION IN PROXIMITY OF MUNICIPAL RIGHT OF WAY.
  - INSTALL NEW DEPRESSED CURBS AS PER CITY STANDARDS.

- ### EROSION AND SEDIMENT CONTROL NOTES
- THE CONTRACTOR SHALL IMPLEMENT BEST MANAGEMENT PRACTICES TO PROVIDE PROTECTION OF THE AREA DRAINAGE SYSTEM AND THE RECEIVING WATER COURSE, DURING CONSTRUCTION ACTIVITIES. THIS INCLUDES LIMITING THE AMOUNT OF EXPOSED SOIL, INSTALLING SILT FENCES AND OTHER EFFECTIVE SEDIMENT TRAPS, AND INSTALLING AND MAINTAINING MUD MATS FOR OUTGOING CONSTRUCTION TRAFFIC DURING CONSTRUCTION ACTIVITIES.
  - PREVENT SOIL LOSS DURING CONSTRUCTION (BY STORM WATER RUNOFF OR WIND EROSION).
  - PROTECT TOPSOIL BY STOCKPILING FOR REUSE.
  - PREVENT SEDIMENTATION OF STORM SEWERS AND RECEIVING STREAMS.
  - PREVENT AIR POLLUTION FROM DUST AND PARTICULATE MATTER.
  - ALL STORM MANHOLES AND CATCHBASIN MANHOLES TO HAVE 300mm SUMPS; ALL CATCHBASINS TO HAVE 600mm SUMPS.
  - INSTALL FILTER BAG INSERT IN ALL STORM MANHOLES AND CATCH BASINS IMPACTED DURING CONSTRUCTION, INCLUDING CATCH BASINS IN THE RIGHT OF WAY.
  - SEDIMENT AND EROSION CONTROL MEASURES MAY BE MODIFIED IN THE FIELD AT THE DISCRETION OF THE CITY OF OTTAWA INSPECTOR OR CONSERVATION AUTHORITY.
  - STORM WATER PUMPED INTO CITY SERVICE SHALL FLOW THROUGH A FILTER SOCK.
  - THE CONTRACTOR ACKNOWLEDGES THAT FAILURE TO IMPLEMENT APPROPRIATE EROSION AND SEDIMENTATION CONTROL MEASURES MAY BE SUBJECT TO PENALTIES IMPOSED BY ANY APPLICABLE REGULATORY AGENCY.

- ### GEOTECHNICAL NOTES
- A GEOTECHNICAL ENGINEER LICENSED IN THE PROVINCE OF ONTARIO SHALL INSPECT ALL SUBGRADE SURFACES FOR FOOTING AND TRENCHES, PIPE BEDDING, CLAY SEALS AND PAVEMENT STRUCTURES PRIOR TO CONSTRUCTION.
  - IT IS STRICTLY RECOMMENDED TO REFER GEOTECHNICAL INVESTIGATION REPORT - GEOTECHNICAL INVESTIGATION - PROPOSED RIVERSIDE SOUTH ELEMENTARY SCHOOL, BRIAN GOOD AVENUE AND SOLARIUM AVENUE, OTTAWA, ONTARIO - PREPARED BY EXP SERVICES INC.
  - STRINGENT CONSTRUCTION CONTROL PROCEDURES SHOULD BE MAINTAINED TO ENSURE THAT UNDERLYING SUBGRADE MOISTURE AND DENSITY CONDITIONS ARE ACHIEVED.
  - SHOULD SURFACE AND SUBSURFACE WATER SEEPAGE OCCUR INTO THE EXCAVATIONS COLLECT ANY WATER ENTERING THE EXCAVATIONS AND REMOVE IT BY PUMPING FROM SUMP.
  - THE SUBDRAINS ILLUSTRATED ON PLANS ARE SCHEMATIC. FULL SCHEME OF SUBDRAINS SHOULD BE INSTALLED ON BOTH SIDES OF THE ACCESS ROADS. SUBDRAINS MUST BE INSTALLED IN THE PROPOSED PARKING AREA AND ACCESS ROADWAY AT LOW POINTS AND SHOULD BE CONTINUOUS BETWEEN CATCHBASINS TO INTERCEPT EXCESS SURFACE AND SUBSURFACE MOISTURE AND TO PREVENT SUBGRADE SOFTENING. THE LOCATION, SIZE AND EXTENT OF SUBDRAINS REQUIRED WITHIN THE PAVED AREAS SHOULD BE SUBMITTED BY CONTRACTOR AND REVIEWED BY THE GEOTECHNICAL ENGINEER IN CONJUNCTION WITH THE PROPOSED SITE GRADING.
  - IT IS RECOMMENDED THAT THE PIPE BEDDING BE 300 MM THICK AND CONSIST OF OPSR GRANULAR A. THE BEDDING MATERIAL SHOULD BE PLACED ALONG THE SIDES AND ON TOP OF THE PIPE TO PROVIDE A MINIMUM COVER OF 300 MM. THE BEDDING SHOULD BE COMPACTED TO AT LEAST 98 PERCENT OF THE SPMD.
  - IF THE BACKFILL IN THE SERVICE TRENCHES WILL CONSIST OF GRANULAR FILL, CLAY SEALS SHOULD BE INSTALLED IN THE SERVICE TRENCHES AT SELECT INTERVALS (SPACING) AS PER CITY OF OTTAWA DRAWING NO. S8. THE SEALS SHOULD BE 1 M WIDE, EXTEND OVER THE ENTIRE TRENCH WIDTH AND FROM THE BOTTOM OF THE TRENCH TO THE UNDERSIDE OF THE PAVEMENT STRUCTURE. THE CLAY SHOULD BE COMPACTED TO 95 PERCENT SPMD. THE PURPOSE OF THE CLAY SEALS IS TO PREVENT THE PERMANENT LOWERING OF THE GROUNDWATER LEVEL. CLAY SEAL LOCATIONS SHALL BE APPROVED BY THE GEOTECHNICAL ENGINEER.
  - BACKFILL AROUND STRUCTURES MANHOLES AND CATCHBASINS SHOULD CONSIST OF FREE-DRAINING GRANULAR MATERIAL CONFORMING TO OPSR GRANULAR B TYPE II IN ORDER TO MINIMIZE DIFFERENTIAL MOVEMENT BETWEEN PAVEMENT AND CATCHBASIN/MANHOLE DUE TO FROST ACTION. WEEP HOLES SHOULD BE PROVIDED IN THE CATCH BASIN/MANHOLES TO FACILITATE DRAINAGE OF ANY WATER THAT MAY ACCUMULATE IN THE GRANULAR FILL.
  - SPECIAL PROVISIONS SHOULD BE ALLOWED BY CONTRACTOR FOR LOADING CONDITIONS ON PAVEMENT STRUCTURES DURING CONSTRUCTION SUCH AS RESTRICTED LANES, HALF-LADDS DURING PAVING AND/OR TEMPORARY CONSTRUCTION ROADWAYS ESPECIALLY IF CONSTRUCTION TIME SPANS THROUGH UNFAVORABLE WEATHER PERIOD.
  - IT IS RECOMMENDED THAT A GEOTEXTILE BE PLACED ON THE SURFACE OF THE SUBGRADE PRIOR TO PLACEMENT OF ANY GRANULAR SUB-BASE. THIS MUST BE ALLOWED FOR BY THE CONTRACTOR AND INSTALLED WHEN DIRECTED BY THE GEOTECHNICAL ENGINEER.
  - WEAKER SUBGRADE MAY DEVELOP AT SUBGRADE LEVEL OF SERVICE TRENCHES. IT IS RECOMMENDED TO PROVIDE ADDITIONAL GRANULAR SUB-BASE, OPSR GRANULAR B TYPE II, AND GEOTEXTILE AT SUBGRADE LEVEL TO THE SATISFACTION OF THE GEOTECHNICAL ENGINEER. FOR PIPE BEDDING REQUIREMENTS REFER TO GEOTECHNICAL REPORT.
  - THE PROPOSED PARKING AREA AND ACCESS ROADS SHOULD BE STRIPPED OF ALL EXISTING FILL, SURFACE AND BURIED TOPSOIL (ORGANIC LAYERS, ORGANIC STAINED SOILS AND OTHER OBVIOUSLY UNSUITABLE MATERIAL). THE SUBGRADE SHOULD BE PROPERLY SHAPED, CROWNED, THEN PROOF ROLLED WITH A HEAVY VIBRATORY ROLLER IN THE FULL-TIME PRESENCE OF A REPRESENTATIVE OF THE GEOTECHNICAL ENGINEER'S OFFICE. ANY SOFT OR SPRONGY SUBGRADE AREAS DETECTED SHOULD BE SUB EXCAVATED AND PROPERLY REPAIRED WITH SUITABLE APPROVED BACKFILL COMPACTED TO 95 PERCENT SPMD (ASTM D698-12E2).
  - THE GRANULAR MATERIALS USED FOR PAVEMENT CONSTRUCTION SHOULD CONFORM TO ONTARIO PROVINCIAL STANDARD SPECIFICATIONS (OPSS 1010) FOR GRANULAR A AND GRANULAR B TYPE II AND SHOULD BE COMPACTED TO 100 PERCENT OF THE SPMD.
  - THE ASPHALTIC CONCRETE USED, AND ITS PLACEMENT SHOULD MEET OPS 1150 OR 1151 REQUIREMENTS. IT SHOULD BE COMPACTED FROM 92 PERCENT TO 97 PERCENT OF THE MDD (ASTM D2024). ASPHALT PLACEMENT SHOULD BE IN ACCORDANCE WITH OPS 310 AND OPS 313.
  - TO MINIMIZE SETTLEMENT OF THE PAVEMENT STRUCTURE OVER SERVICE TRENCHES, THE TRENCH BACKFILL MATERIAL WITHIN THE FROST ZONE, TO 1.8 M DEPTH BELOW FINAL GRADE, SHOULD MATCH THE EXISTING MATERIAL ALONG THE TRENCH WALLS TO MINIMIZE DIFFERENTIAL FROST HEAVING OF THE SUBGRADE SOIL. PROVIDED THIS MATERIAL IS COMPACTIBLE. OTHERWISE, FROST TAPERS MAY BE REQUIRED.
  - THE MUNICIPAL SERVICES SHOULD BE INSTALLED IN SHORT OPEN TRENCH SECTIONS THAT ARE EXCAVATED AND BACKFILLED THE SAME DAY.
  - TRENCH BACKFILL AND SUBGRADE FILL SHOULD CONSIST OF OPS 1010 GRANULAR B TYPE II FOR THE PLAY STRUCTURE AND OPS 1010 SELECT SUBGRADE MATERIAL (SSM) FOR THE SPORTS FIELD, PARKING LOT AND ACCESS ROADS, PLACED IN 300 MM THICK LIFTS AND EACH LIFT COMPACTED TO 95 PERCENT SPMD; AND FILL FOR LANDSCAPED AREAS SHOULD BE CLEAN FILL, FREE OF DEBRIS, TOPSOIL (ORGANIC SOIL), COBBLES AND BOLDERS PLACED IN 300 MM THICK LIFTS AND EACH LIFT COMPACTED TO 92 PERCENT SPMD.

- Limit of 100+20% year ponding**  
100 year Allowable release rate 86.40 L/s  
100 year Ponding Elevation 91.43  
100 year Ponding depth 0.33m  
100 year Ponding volume 68m<sup>3</sup>  
5 year No Surface Ponding
- Limit of 100 year ponding**  
100 year Allowable release rate 86.40 L/s  
100 year Ponding Elevation 91.40  
100 year Ponding depth 0.30m  
100 year Ponding volume 48m<sup>3</sup>  
5 year No Surface Ponding

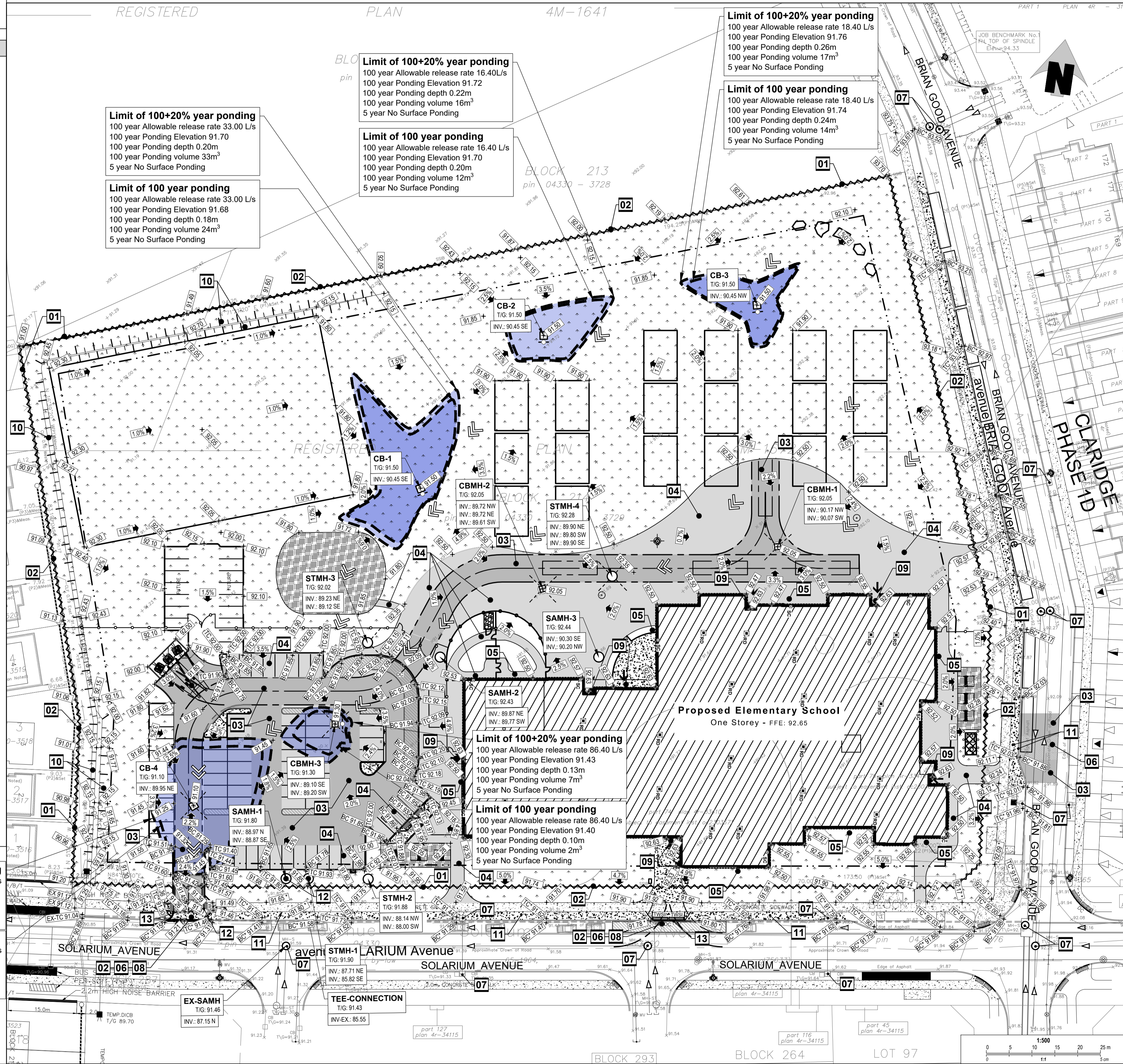

- Limit of 100+20% year ponding**  
100 year Allowable release rate 33.00 L/s  
100 year Ponding Elevation 91.70  
100 year Ponding depth 0.20m  
100 year Ponding volume 33m<sup>3</sup>  
5 year No Surface Ponding
- Limit of 100 year ponding**  
100 year Allowable release rate 33.00 L/s  
100 year Ponding Elevation 91.68  
100 year Ponding depth 0.18m  
100 year Ponding volume 24m<sup>3</sup>  
5 year No Surface Ponding

- Limit of 100+20% year ponding**  
100 year Allowable release rate 16.40 L/s  
100 year Ponding Elevation 91.72  
100 year Ponding depth 0.22m  
100 year Ponding volume 16m<sup>3</sup>  
5 year No Surface Ponding
- Limit of 100 year ponding**  
100 year Allowable release rate 16.40 L/s  
100 year Ponding Elevation 91.70  
100 year Ponding depth 0.20m  
100 year Ponding volume 12m<sup>3</sup>  
5 year No Surface Ponding

- Limit of 100+20% year ponding**  
100 year Allowable release rate 18.40 L/s  
100 year Ponding Elevation 91.76  
100 year Ponding depth 0.26m  
100 year Ponding volume 17m<sup>3</sup>  
5 year No Surface Ponding
- Limit of 100 year ponding**  
100 year Allowable release rate 18.40 L/s  
100 year Ponding Elevation 91.74  
100 year Ponding depth 0.24m  
100 year Ponding volume 14m<sup>3</sup>  
5 year No Surface Ponding

- Limit of 100+20% year ponding**  
100 year Allowable release rate 86.40 L/s  
100 year Ponding Elevation 91.43  
100 year Ponding depth 0.13m  
100 year Ponding volume 7m<sup>3</sup>  
5 year No Surface Ponding
- Limit of 100 year ponding**  
100 year Allowable release rate 86.40 L/s  
100 year Ponding Elevation 91.40  
100 year Ponding depth 0.10m  
100 year Ponding volume 2m<sup>3</sup>  
5 year No Surface Ponding



**Jp2g Consultants Inc.**  
ENGINEERS - PLANNERS - PROJECT MANAGERS  
1150 Morrison Drive, Suite 410, Ottawa, ONT.  
Phone: (613) 828-7800 Fax: (613) 828-2900  
Job No: 20-1095D



No.	Description	YYYY-MM-DD
1	ISSUED FOR SITE PLAN CONTROL REV-1	2022-10-10

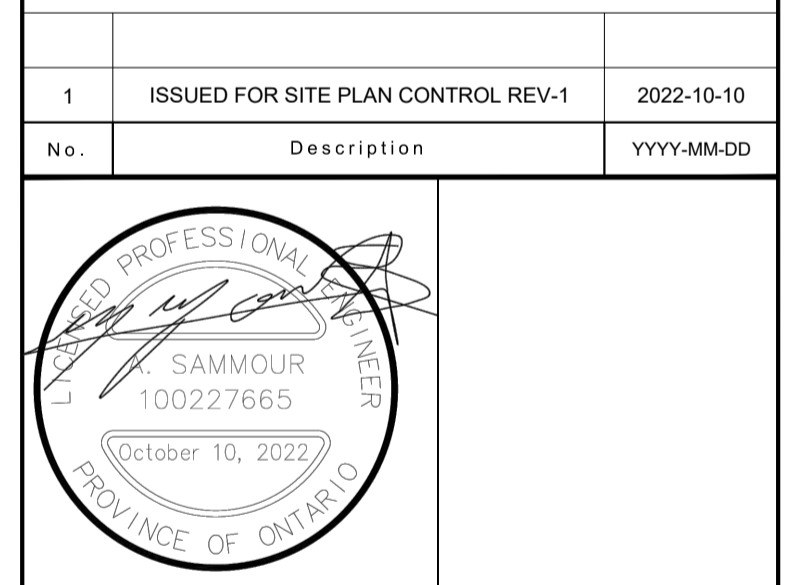

Client: **P R PYE & RICHARDS - TEMPRANO & YOUNG ARCHITECTS INC.**  
824 Meath St. Suite 200 613.724.7700  
Ottawa, ON K1Z 6E8 info@prty.ca

Project: **OCSB Riverside South Elementary School**  
Solarium & Brian Good, Ottawa, Ontario

Drawing Title: **Site Grading, Erosion and Sediment Control Plan**

Do not scale. Refer any dimensional errors and/or possible trade interference/conflict to the architect for clarification prior to commencement of the work. The conditions of the contract apply.

Project No.	Drawing No.
Scale: As shown	<b>C2</b>
Drawn By: R.I.	
Checked: A.S.	
Date:	

Revision No.

**General Notes**

- DRAWINGS TO BE READ IN CONJUNCTION WITH ARCHITECTURAL AND LANDSCAPE DRAWINGS
- ALL SERVICES, MATERIALS, CONSTRUCTION METHODS AND INSTALLATIONS SHALL BE IN ACCORDANCE WITH THE LATEST STANDARDS AND REGULATIONS OF THE CITY OF OTTAWA STANDARD SPECIFICATIONS AND DRAWINGS, ONTARIO PROVINCIAL SPECIFICATION STANDARD SPECIFICATION (OPSS) AND ONTARIO PROVINCIAL STANDARD DRAWINGS (OPSD), UNLESS OTHERWISE SPECIFIED, TO THE SATISFACTION OF THE CITY AND THE CONSULTANT
- THE POSITION OF EXISTING POLE LINES, CONDUITS, WATERMANS, SEWERS AND OTHER UNDERGROUND AND ABOVEGROUND UTILITIES, STRUCTURES AND APPURTENANCES IS NOT NECESSARILY SHOWN ON THE CONTRACT DRAWING, AND WHERE SHOWN, THE ACCURACY OF THE POSITION OF SUCH UTILITIES AND STRUCTURES IS NOT GUARANTEED. PRIOR TO CONSTRUCTION, THE CONTRACTOR SHALL SATISFY HIMSELF OF THE EXACT LOCATION OF ALL SUCH UTILITIES AND STRUCTURES, AND SHALL ASSUME ALL LIABILITY FOR DAMAGE TO THEM DURING THE COURSE OF CONSTRUCTION, ANY RELOCATION OF EXISTING UTILITIES REQUIRED BY THE DEVELOPMENT OF SUBJECT LANDS IS TO BE UNDERTAKEN AT CONTRACTOR'S EXPENSE.
- THE CONTRACTOR MUST NOTIFY ALL EXISTING UTILITY COMPANY OFFICIALS FIVE (5) BUSINESS DAYS PRIOR TO START OF CONSTRUCTION AND HAVE ALL EXISTING UTILITIES AND SERVICES LOCATED IN THE FIELD OR EXPOSED PRIOR TO THE START OF CONSTRUCTION, INCLUDING BUT NOT LIMITED TO POWER, COMMUNICATION AND GAS LINES.
- ALL TRENCHING AND EXCAVATIONS TO BE IN ACCORDANCE WITH THE LATEST REVISIONS OF THE OCCUPATIONAL HEALTH AND SAFETY ACT AND REGULATIONS FOR CONSTRUCTION PROJECTS AND AS PER THE RECOMMENDATIONS INCLUDED IN THE GEOTECHNICAL REPORT.
- REFER TO ARCHITECTS PLANS FOR BUILDING DIMENSIONS, LAYOUT AND REMOVALS. REFER TO LANDSCAPE PLAN FOR LANDSCAPED DETAILS AND OTHER RELEVANT INFORMATION. ALL INFORMATION SHALL BE CONFIRMED PRIOR TO COMMENCEMENT OF CONSTRUCTION.
- TOPOGRAPHIC SURVEY COMPLETED AND PROVIDED BY FARLEY, SMITH AND DENNIS SURVEYING LTD., FILE NO. 482-20, DATED OCTOBER 1, 2020. CONTRACTOR TO VERIFY IN THE FIELD PRIOR TO CONSTRUCTION OF ANY WORK AND NOTIFY THE ENGINEER OF ANY DISCREPANCIES.
- ALL ELEVATIONS ARE GEODETIC AND UTILIZE METRIC UNITS. VERIFY THAT JOB BENCHMARKS HAVE NOT BEEN ALTERED OR DISTURBED.
- ALL GROUND SURFACES SHALL BE EVENLY GRADED WITHOUT PONDING AREAS AND WITHOUT LOW POINTS EXCEPT WHERE APPROVED SWALE OR CATCH BASIN OUTLETS ARE PROVIDED.
- ALL EDGES OF DISTURBED PAVEMENT SHALL BE SAW CUT TO FORM A NEAT AND STRAIGHT LINE PRIOR TO PLACING NEW PAVEMENT. PAVEMENT REINSTATEMENT SHALL BE WITH STEP JOINTS OF 500mm WIDTH MINIMUM.
- ALL DISTURBED AREAS OUTSIDE PROPOSED GRADING LIMITS TO BE RESTORED TO ORIGINAL ELEVATIONS AND CONDITIONS UNLESS OTHERWISE SPECIFIED. ALL RESTORATION SHALL BE COMPLETED WITH THE GEOTECHNICAL REQUIREMENTS FOR BACKFILL AND COMPACTION.
- ABUTTING PROPERTY GRADES TO BE MATCHED UNLESS OTHERWISE SHOWN.
- CONTRACTOR SHALL OBTAIN AND PAY FOR ALL NECESSARY PERMITS AND APPROVALS FROM THE MUNICIPAL AUTHORITIES PRIOR TO COMMENCING CONSTRUCTION, INCLUDING WATER PERMIT AND ROAD CUT PERMIT.
- MINIMIZE DISTURBANCE TO EXISTING VEGETATION DURING THE EXECUTION OF ALL WORKS.
- EXCAVATE AND REMOVE ALL ORGANIC MATERIAL AND DEBRIS LOCATED WITHIN THE PROPOSED BUILDING, PARKING AND ROADWAY LOCATIONS. ALL EXCESS SOIL MANAGEMENT, TESTING AND DISPOSAL MUST COMPLY WITH CURRENT OREG. 406/19. ALL ASSOCIATED COSTS ARE TO BE BORNE BY THE CONTRACTOR.
- AT PROPOSED UTILITY CONNECTION POINTS AND CROSSINGS (I.E. STORM SEWER, SANITARY SEWER, WATER, ETC.) THE CONTRACTOR SHALL DETERMINE THE PRECISE LOCATION AND DEPTH OF EXISTING UTILITIES AND REPORT ANY DISCREPANCIES OR CONFLICTS TO THE ENGINEER BEFORE COMMENCING WORK.
- CONTRACTOR TO OBTAIN POST-CONSTRUCTION TOPOGRAPHIC SURVEY, COMPLETED BY OLS OR P.ENG CONFIRMING COMPLIANCE WITH DESIGN GRADING AND SERVICES SURVEY IS TO INCLUDE LOCATION AND INVERTS FOR BURIED UTILITIES.
- ABIDE BY RECOMMENDATIONS OF GEOTECHNICAL REPORT REPORT ANY VARIATIONS IN OBSERVED CONDITIONS FROM THOSE INCLUDED IN REPORT.
- REPORT REFERENCES:  
1. GEOTECHNICAL INVESTIGATION PREPARED BY EXP SERVICES INC., PROJECT NO.: OTT-00245378-R0, DATED NOVEMBER 11, 2020.
- PROVIDE CCTV INSPECTION REPORT FOR ALL SEWERS AND CATCHBASIN LEADS 200mm DIAMETER AND LARGER. REPEAT CCTV INSPECTION FOLLOWING RECTIFICATION OF ANY DEFICIENCIES.

**Notes: Sanitary Sewer and Manholes**

- ALL SANITARY SEWER, SANITARY SEWER APPURTENANCES AND CONSTRUCTION METHODS SHALL CONFORM TO THE CURRENT CITY OF OTTAWA STANDARDS AND SPECIFICATIONS. PROVIDE CCTV INSPECTION REPORTS FOR ALL NEW SANITARY PIPING. PROVIDE DYE TESTING FOR NEW SERVICES.
- SANITARY SEWER PIPE SIZE: 150mm DIAMETER AND GREATER TO BE PVC-SR-35 UNLESS SPECIFIED OTHERWISE WITH RUBBER GASKET TYPE JOINTS IN CONFORMANCE WITH CSA B-182.2.3.4.
- SEWER BEDDING AS PER CITY OF OTTAWA DETAIL S6.
- ALL SANITARY MANHOLES 1200mm IN DIAMETER TO BE AS PER OPSD 701.01. FRAME AND COVER TO BE AS PER CITY OF OTTAWA STANDARD S25 AND S24.
- MAINTENANCE HOLE BENCHING AND PIPE OPENING ALTERNATIVES AS PER THE OPSD 701.021
- ANY SANITARY SEWER WITH LESS THAN 2.0m COVER REQUIRES THERMAL INSULATION AS PER CITY OF OTTAWA STANDARD W22, OR APPROVED BY THE ENGINEER.

**Notes: Storm Sewer and Manholes**

- ALL STORM SEWER MATERIALS AND CONSTRUCTION METHODS SHALL CONFORM TO THE CURRENT CITY OF OTTAWA STANDARDS AND SPECIFICATIONS. PROVIDE CCTV INSPECTION REPORTS FOR ALL NEW STORM SEWERS, SERVICES AND CB LEADS.
- STORM SEWERS 450mm DIAMETER AND SMALLER SHALL BE PVC-SR-35, WITH RUBBER GASKET PER CSA A-257.3.
- STORM SEWER LARGER THAN 450mm SHALL BE REINFORCED CONCRETE CLASS 100.
- SEWER BEDDING AS PER CITY OF OTTAWA DETAIL S6.
- ALL STORM MANHOLES TO BE AS PER MANHOLE AND CATCHBASIN SCHEDULE.
- ANY NEW OR EXISTING STORM SEWER WITH LESS THAN 2.0m COVER REQUIRES THERMAL INSULATION AS PER CITY OF OTTAWA STANDARD W22, OR APPROVED BY THE ENGINEER.
- CB IN LANDSCAPE AREAS SHALL BE AS PER CITY OF OTTAWA STANDARD S29, S30 AND S31.
- ALL CATCHBASIN LEADS TO BE MINIMUM 200mm DIAMETER AT MINIMUM 1.0% SLOPE UNLESS OTHERWISE SPECIFIED.
- STORM CATCHBASINS AS PER OPSD 705.010 AND FRAME COVER AS PER CITY STANDARD DRAWINGS S19. STORM CATCHBASIN AS INDICATED IN TABLE WITH SLUMP ADJUSTMENT SECTIONS SHALL BE AS PER OPSD 704.010.
- INSTALLATION OF FLOW CONTROL ICDS TO BE VERIFIED BY QUALITY VERIFICATION ENGINEER RETAINED BY CONTRACTOR.

**Parking Lot and Work in Public Rights of Way**

- \*\* CONTRACTOR IS RESPONSIBLE FOR ALL INSTALLATION, MONITORING, REPAIR AND REMOVAL OF ALL EROSION AND SEDIMENT CONTROL FEATURES.\*\***
- PRIOR TO START OF CONSTRUCTION:
    - INSTALL SILT FENCE IN LOCATION SHOWN ON DWG C2.
    - INSTALL FILTER FABRIC OR SILT SACK FILTERS IN ALL THE CATCHBASINS AND MANHOLES TO REMAIN DURING CONSTRUCTION WITHIN THE SITE (SEE TYPICAL DETAILS).
    - INSPECT MEASURES IMMEDIATELY AFTER INSTALLATION.
  - DURING CONSTRUCTION:
    - MINIMIZE THE EXTENT OF DISTURBED AREAS AND THE DURATION OF EXPOSURE AND IMPACTS TO EXISTING GRADING.
    - PERMETER VEGETATION TO REMAIN IN PLACE UNTIL PERMANENT STORM WATER MANAGEMENT IS IN PLACE OTHERWISE, IMMEDIATELY INSTALL SILT FENCE WHEN THE EXISTING SITE IS DISTURBED AT THE PERIMETER.
    - PROTECT DISTURBED AREAS FROM OVERLAND FLOW BY PROVIDING TEMPORARY SWALES TO THE SATISFACTION OF THE FIELD ENGINEER. TIE-IN TEMPORARY SWALE TO EXISTING C&S AS REQUIRED.
    - PROVIDE TEMPORARY COVER SUCH AS SEEDING OR MULCHING IF DISTURBED AREA WILL NOT BE REHABILITATED WITHIN 30 DAYS.
    - INSPECT SILT FENCES, FILTER FABRIC FILTERS AND CATCH BASIN SUMPMS WEEKLY AND WITHIN 24 HOURS AFTER A STORM EVENT. CLEAN AND REPAIR WHEN NECESSARY.
    - DRAWING TO BE REVIEWED AND REVISED AS REQUIRED DURING CONSTRUCTION.
    - EROSION CONTROL FENCING TO BE ALSO INSTALLED AROUND THE BASE OF ALL STOCKPILES.
    - DO NOT LOCATE TOPSOIL PILES AND EXCAVATION MATERIAL CLOSER THAN 2.5m FROM ANY PAVED SURFACE, OR ONE WHICH IS TO BE PAVED BEFORE THE PILE IS REMOVED. ALL TOPSOIL PILES ARE TO BE SEEDED IF THEY ARE TO REMAIN ON SITE LONG ENOUGH FOR SEEDS TO GROW (LONGER THAN 30 DAYS).
    - CONTROL WIND-BLOWN DUST OFF SITE BY SEEDING TOPSOIL PILES AND OTHER AREAS TEMPORARILY (PROVIDE WATERING AS REQUIRED AND TO THE SATISFACTION OF THE ENGINEER).
    - NO ALTERNATE METHODS OF EROSION PROTECTION SHALL BE PERMITTED UNLESS APPROVED BY THE FIELD ENGINEER.
    - CITY ROADWAY AND SIDEWALK TO BE CLEANED OF ALL SEDIMENT FROM VEHICULAR TRACKING AS REQUIRED.
    - DURING WET CONDITIONS, TIRES OF ALL VEHICLE/EQUIPMENT LEAVING THE SITE ARE TO BE SCRAPPED.
    - ANY MUD/MATERIAL TRACKED ONTO THE ROAD SHALL BE REMOVED IMMEDIATELY BY HAND OR RUBBER TIRE LOADER.
    - TAKE ALL NECESSARY STEPS TO PREVENT BUILDING MATERIAL, CONSTRUCTION DEBRIS OR WASTE BEING SPILLED OR TRACKED ONTO ADJUTING PROPERTIES OR PUBLIC STREETS DURING CONSTRUCTION AND PROCEED IMMEDIATELY TO CLEAN UP ANY AREAS SO AFFECTED.
    - ALL NECESSARY STEPS TO PREVENT BUILDING MATERIAL, CONSTRUCTION DEBRIS OR WASTE BEING SPILLED OR TRACKED ONTO ADJUTING PROPERTIES OR PUBLIC STREETS DURING CONSTRUCTION AND PROCEED IMMEDIATELY TO CLEAN UP ANY AREAS SO AFFECTED.
    - THE CONTRACTOR SHALL IMPLEMENT BEST MANAGEMENT PRACTICES, TO PROVIDE FOR PROTECTION OF THE AREA DRAINAGE SYSTEM AND THE RECEIVING WATERCOURSE, DURING CONSTRUCTION ACTIVITIES. THE CONTRACTOR ACKNOWLEDGES THAT FAILURE TO IMPLEMENT APPROPRIATE EROSION AND SEDIMENT CONTROL MEASURES MAY BE SUBJECT TO PENALTIES IMPOSED BY ANY APPLICABLE REGULATORY AGENCY.

**Notes: Watermain**

- ALL WATERMAIN AND WATERMAIN APPURTENANCES, MATERIALS, CONSTRUCTION AND TESTING METHODS SHALL CONFORM TO THE CURRENT CITY OF OTTAWA STANDARDS AND SPECIFICATIONS.
- ALL WATERMAIN 300mm DIAMETER AND SMALLER TO BE POLY VINYL CHLORIDE (PVC) CLASS 150 DR 18 MEETING AWWA SPECIFICATION C900.
- ALL WATERMAIN TO BE INSTALLED AT MINIMUM COVER OF 2.4m BELOW FINISHED GRADE. WHERE WATERMANS CROSS UNDER OTHER UTILITIES, A MINIMUM 0.30m CLEARANCE SHALL BE MAINTAINED. WHERE WATERMANS CROSS UNDER OTHER UTILITIES, A MINIMUM 0.50m CLEARANCE SHALL BE MAINTAINED. WHERE THE MINIMUM SEPARATION CANNOT BE ACHIEVED, THE WATERMAIN SHALL BE INSTALLED AS PER CITY OF OTTAWA STANDARDS W25 AND W25.2. WHERE 2.4m MINIMUM DEPTH CANNOT BE ACHIEVED, THERMAL INSULATION SHALL BE PROVIDED AS PER CITY OF OTTAWA STANDARD W22. WHERE A WATERMAIN IS IN CLOSE PROXIMITY TO AN OPEN STRUCTURE, THERMAL INSULATION SHALL BE PROVIDED AS PER CITY OF OTTAWA STANDARD W23.
- CONCRETE THRUST BLOCKS AND MECHANICAL RESTRAINTS ARE TO BE INSTALLED AT ALL TEES, BENDS, HYDRANTS, REDUCERS, ENDS OF MAINS AND CONNECTIONS 100mm AND LARGER, IN ACCORDANCE WITH CITY OF OTTAWA STANDARDS W25.3 & W25.4.
- CATHODIC PROTECTION REQUIRED FOR ALL IRON FITTINGS AS PER CITY OF OTTAWA STANDARD W40 & W42.
- ALL VALVES AND VALVE BOXES AND CHAMBERS, HYDRANTS, AND HYDRANT VALVES AND ASSEMBLES SHALL BE INSTALLED AS PER CITY OF OTTAWA STANDARD.
- FIRE HYDRANT LOCATION AND INSTALLATION AS PER CITY OF OTTAWA STANDARD W18 & W19. CONTRACTOR TO PROVIDE FLOW TEST AND PAINTING OF NEW HYDRANT IN ACCORDANCE WITH CITY STANDARDS.
- IF WATER MAIN MUST BE DEFLECTED TO MEET ALIGNMENT, ENSURE THAT THE AMOUNT OF DEFLECTION USED IS LESS THAN HALF THAT RECOMMENDED BY THE MANUFACTURER.

**Parking Lot and Work in Public Rights of Way**

- CONTRACTOR TO REINSTATE ROAD CUTS AS PER CITY OF OTTAWA DETAIL R10.
- CONTRACTOR TO PREPARE SUBGRADE, INCLUDING PROOFROLLING, TO THE SATISFACTION OF THE GEOTECHNICAL CONSULTANT PRIOR TO THE COMMENCEMENT OF PLACEMENT OF GRANULAR B MATERIAL.
- FILL TO BE PLACED AND COMPACTED PER THE GEOTECHNICAL REPORT REQUIREMENTS.
- CONTRACTOR TO SUPPLY, PLACE AND COMPACT GRANULAR B MATERIAL IN ACCORDANCE WITH THE RECOMMENDATIONS OF THE GEOTECHNICAL CONSULTANT. CONTRACTOR TO PROVIDE CONSULTANT WITH SAMPLES OF GRANULAR B MATERIAL FOR TESTING AND CERTIFICATION FROM THE GEOTECHNICAL CONSULTANT THAT THE MATERIAL MEETS THE GRADATION REQUIREMENTS SPECIFIED IN THE GEOTECHNICAL REPORT.
- GRANULAR A MATERIAL TO BE PLACED ONLY UPON APPROVAL BY THE GEOTECHNICAL CONSULTANT OF GRANULAR B PLACEMENT.
- CONTRACTOR TO SUPPLY, PLACE AND COMPACT GRANULAR A MATERIAL IN ACCORDANCE WITH THE RECOMMENDATIONS OF THE GEOTECHNICAL CONSULTANT. CONTRACTOR TO PROVIDE CONSULTANT WITH SAMPLES OF GRANULAR A MATERIAL FOR TESTING AND CERTIFICATION FROM THE GEOTECHNICAL CONSULTANT THAT THE MATERIAL MEETS THE GRADATION REQUIREMENTS SPECIFIED IN THE GEOTECHNICAL REPORT.
- ASPHALT MATERIAL TO BE PLACED ONLY UPON APPROVAL BY THE GEOTECHNICAL CONSULTANT OF GRANULAR A PLACEMENT.
- CONTRACTOR TO SUPPLY, PLACE AND COMPACT ASPHALT MATERIAL IN ACCORDANCE WITH THE RECOMMENDATIONS OF THE GEOTECHNICAL CONSULTANT. CONTRACTOR TO PROVIDE CONSULTANT WITH SAMPLES OF ASPHALT MATERIAL FOR TESTING AND CERTIFICATION FROM THE GEOTECHNICAL CONSULTANT THAT THE MATERIAL MEETS THE REQUIREMENTS SPECIFIED IN THE GEOTECHNICAL REPORT.
- CONTRACTOR IS RESPONSIBLE FOR ESTABLISHING LINE AND GRADE IN ACCORDANCE WITH THE PLANS, AND FOR PROVIDING THE CONSULTANT WITH VERIFICATION PRIOR TO PLACEMENT.
- ALL EXCESS MATERIAL TO BE HAULED OFF-SITE AND DISPOSED OF AT AN APPROVED DUMP SITE. SHOULD THE CONTRACTOR DISCOVER ANY HAZARDOUS MATERIAL, CONTRACTOR IS TO NOTIFY CONSULTANT, CONSULTANT TO DETERMINE APPROPRIATE DISPOSAL METHOD/LOCATION.
- PAVEMENT STRUCTURE (MATERIAL TYPES AND THICKNESS) FOR HEAVY DUTY AND LIGHT DUTY AREAS TO BE AS SPECIFIED IN THE GEOTECHNICAL REPORT AND SHOWN ON THE PLANS.

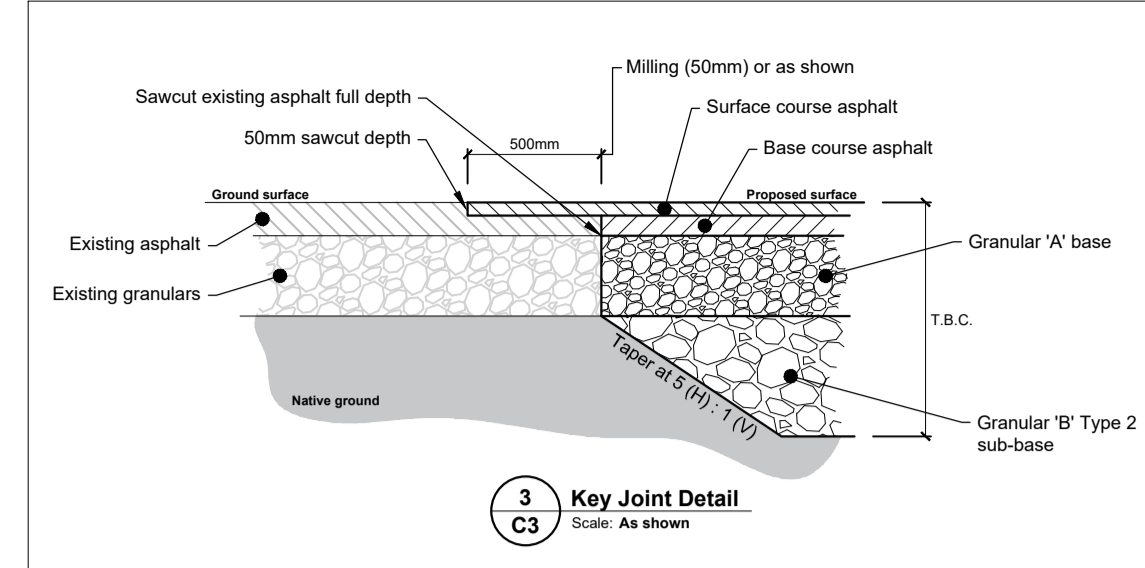
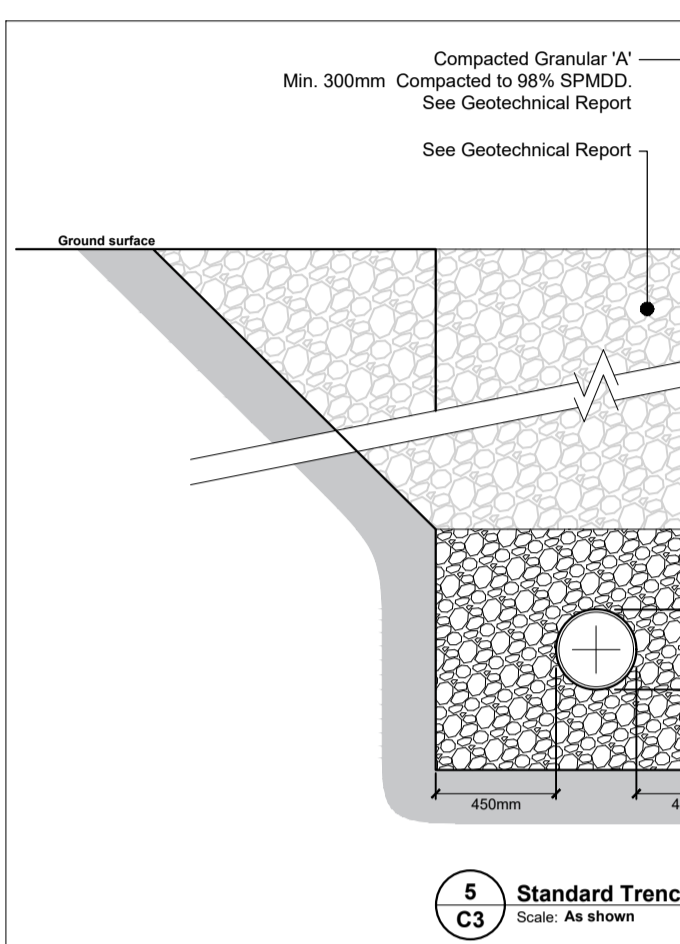
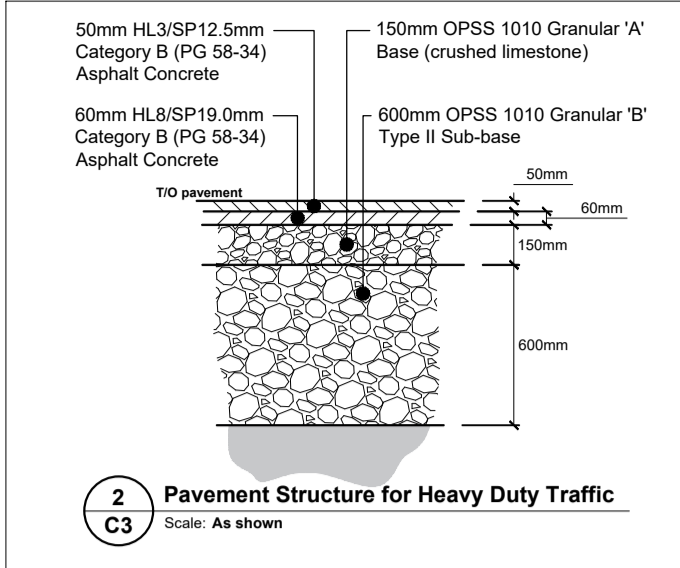
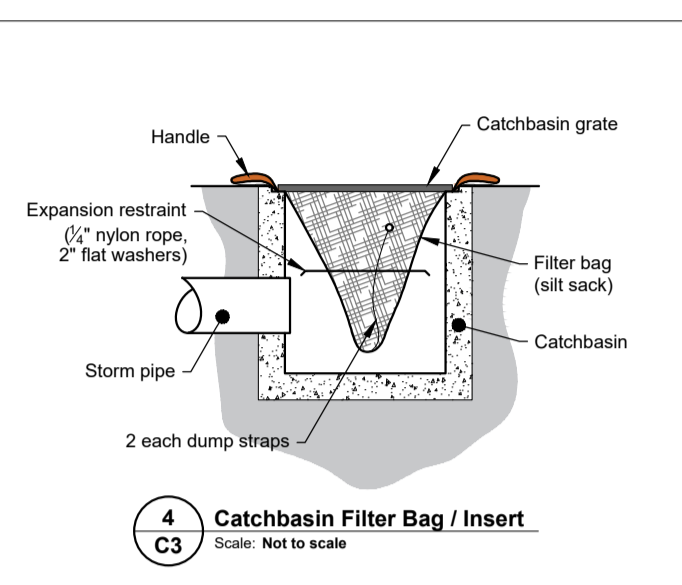
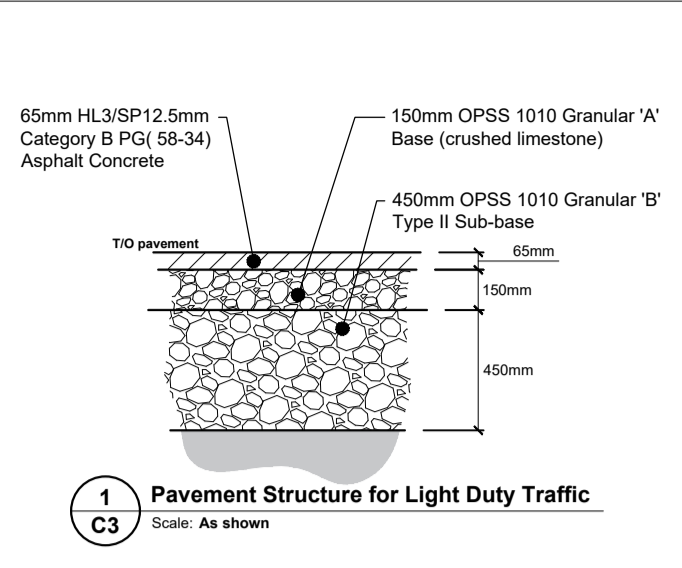

MANHOLE AND CATCHBASIN SCHEDULE				
STRUCTURE ID	TOP OF FRAME ELEVATION (m)	PIPE INVERT ELEVATION (m)	STRUCTURE SIZE (mm) / OPSD No.	FRAME (CITY OF OTTAWA)
CB-1	91.500	90.45 SE	600 x 600 / 705.010	S19
CB-2	91.500	90.45 SE	600 x 600 / 705.010	S19
CB-3	91.500	90.45 NW	600 x 600 / 705.010	S19
CB-4	91.100	89.95 NE	600 x 600 / 705.010	S19
CBMH-1	92.050	90.17 NW / 90.07 SW	1200 / 701.010	S25 / S28.1
CBMH-2	92.050	89.72 NW / 89.72 NE / 89.61 SW	1200 / 701.010	S25 / S28.1
CBMH-3	91.300	89.10 SE / 89.20 SW	1200 / 701.010	S25 / S28.1
STMH-1	91.900	87.71 NE / 85.82 SE	1500 / 701.011 / 1003-010 (DROP PIPE STRUCTURE)	S25 / S24
STMH-2	91.880	88.14 NW / 80.00 SW	1200 / 701.010	S25 / S24
STMH-3	92.020	89.23 NE / 89.12 SE	1200 / 701.010	S25 / S24
STMH-4	92.280	89.90 NE / 89.80 SW / 89.90 SE	1200 / 701.010	S25 / S24
SAMH-1	91.800	88.97 N / 88.87 SE	1200 / 701.010	S25 / S24.1
SAMH-2	92.430	89.87 NE / 89.77 SW	1200 / 701.010	S25 / S24.1
SAMH-3	92.440	90.30 SE / 90.20 NW	1200 / 701.010	S25 / S24.1

CROSSING TABLE					
LOCATION	OVER / UNDER	T/G	INVERT	OBVERT	CLEARANCE (m)
△	NEW WATERMAIN - EXISTING SANITARY SEWER	92.03	89.73 (WM)	89.23 (SANITARY)	0.50
△	NEW WATERMAIN - EXISTING STORM SEWER	92.00	89.68 (WM)	88.83 (STORM)	0.85
△	NEW WATERMAIN - NEW STORM SEWER	91.88	89.73 (WM)	88.73 (STORM)	1.00
△	NEW WATERMAIN - EXISTING SANITARY SEWER	91.92	89.74 (WM)	89.24 (SANITARY)	0.50
△	NEW STORM SEWER - NEW WATERMAIN	92.41	89.97 (STORM)	89.47 (WM)	0.50
△	NEW SANITARY SEWER - NEW STORM SEWER	91.56	89.50 (SANITARY)	89.10 (STORM)	0.40
△	NEW SANITARY SEWER - EXISTING STORM SEWER	91.38	88.50 (SANITARY)	86.50 (STORM)	2.00

WATER SERVICE TABLE			
ID	DESCRIPTION	FINISHED GRADE (m)	T/O WATERMAIN (m)
①	BUILDING CONNECTION	92.650	90.250
②	45° HORIZONTAL BEND	92.480	90.070
③	45° HORIZONTAL BEND	92.460	90.070
④	TEE 150X150MM	92.440	90.030
⑤	45° HORIZONTAL BEND	92.560	90.160
⑥	45° HORIZONTAL BEND	92.570	90.160
⑦	45° HORIZONTAL BEND	92.430	90.030
⑧	45° HORIZONTAL BEND	92.420	90.030

NOTE: PROVIDE MINIMUM 2.4m COVER OVER T/O WATERMAIN TO FINISHED GRADE. OTHERWISE PROVIDE THERMAL INSULATION HL40 AS PER DETAIL Z/C1.



**Jp2g Consultants Inc.**  
ENGINEERS - PLANNERS - PROJECT MANAGERS  
1150 Morrison Drive, Suite 410, Ottawa, ONT.  
Phone: (613) 828-7620 Fax: (613) 828-2900  
Jp2g No.: 20-1095D



No.	Description	YYYY-MM-DD
1	ISSUED FOR SITE PLAN CONTROL REV-1	2022-10-10

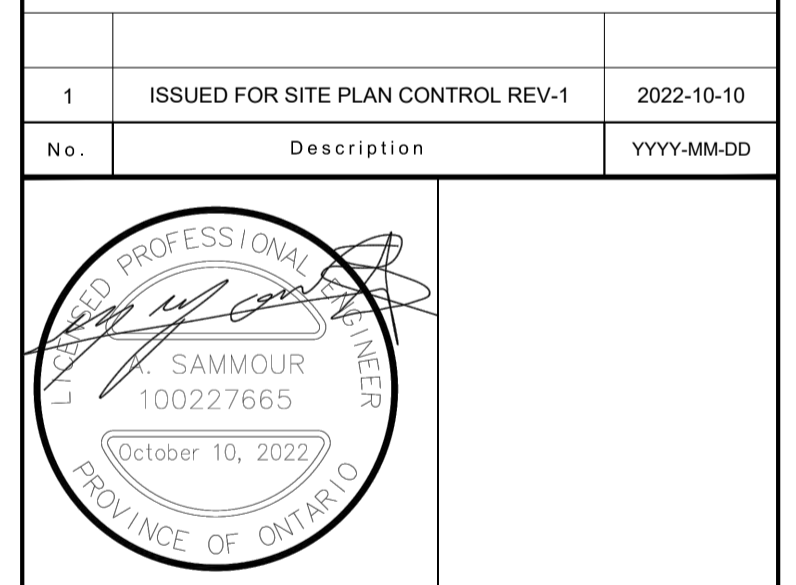

Client: **P R PYE & RICHARDS - TEMPRANO & YOUNG ARCHITECTS INC.**  
824 Meath St. Suite 200 613. 724. 7700  
Ottawa, ON K1Z 6E8 info@prty.ca

Project: **OCSB Riverside South Elementary School**  
Solarium & Brian Good, Ottawa, Ontario

Drawing Title: **Details, Notes and Schedules**

Project No.	Drawing No.
Scale: <b>As shown</b>	<b>C3</b>
Drawn By: <b>R.I.</b>	
Checked: <b>A.S.</b>	
Date	

LEGEND

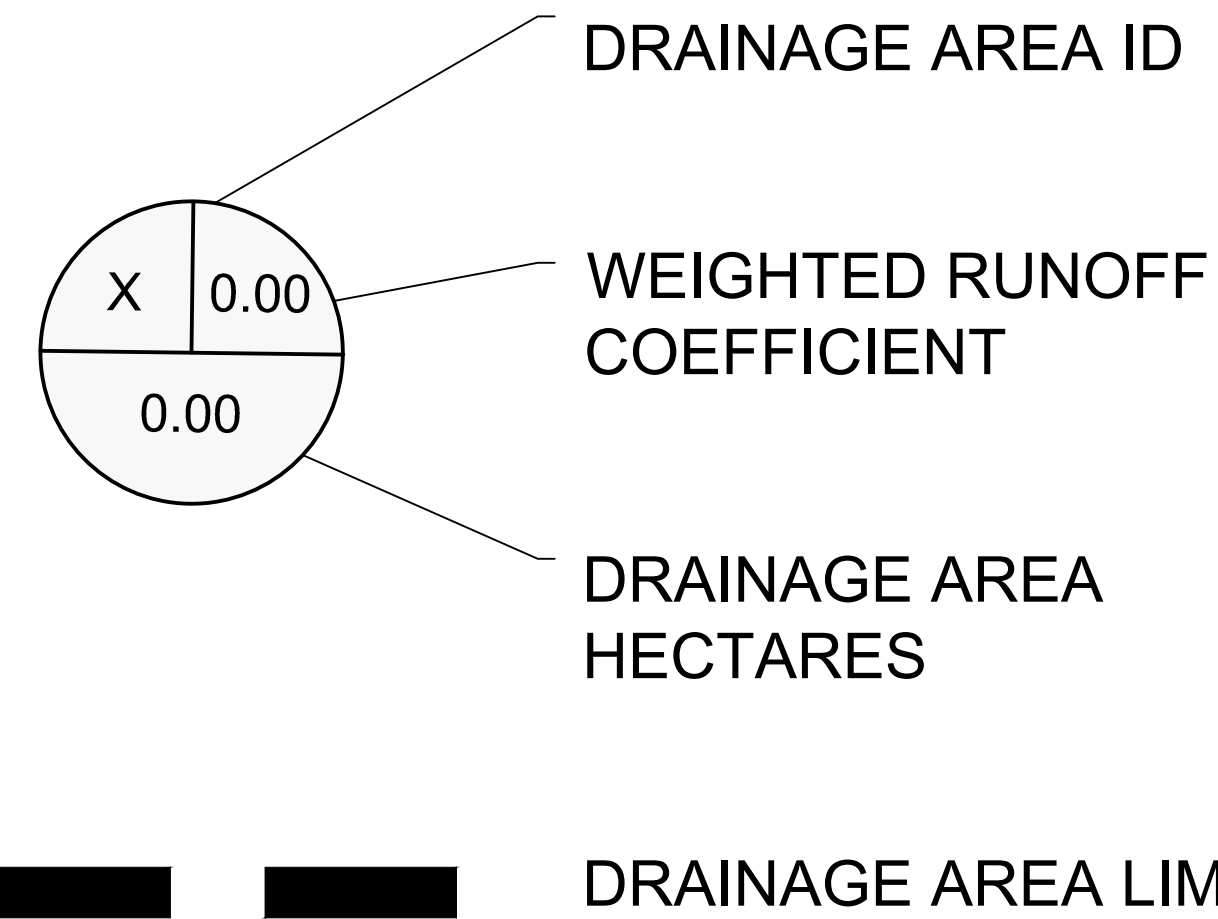

\* ALLOWABLE RELEASE RATE = 410 l/s .  
REFER TO PRE-CONSULTING MEETING NOTES : JULY 25th,2022 .

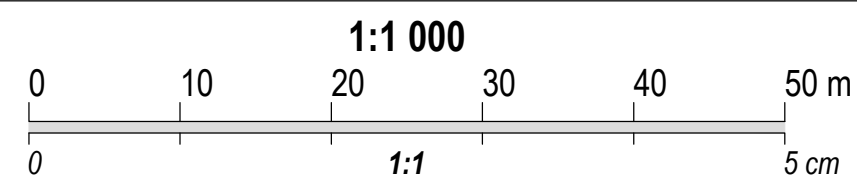
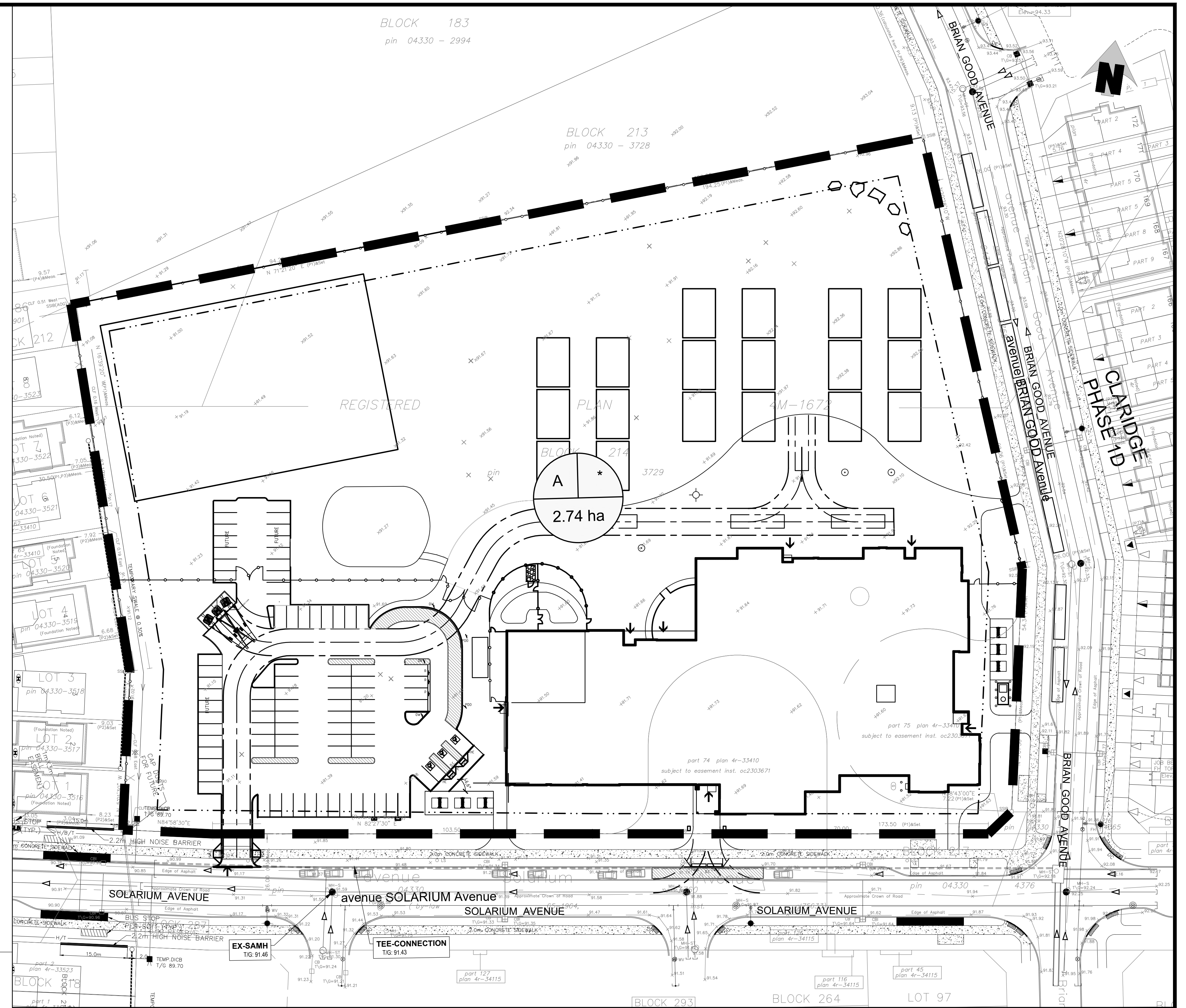

**Jp2g Consultants Inc.**  
ENGINEERS • PLANNERS • PROJECT MANAGERS

12 INTERNATIONAL DRIVE, PEMBROKE, ON Phone: (613)735-2507, Fax:(613)735-4513  
1150 MORRISON DRIVE, SUITE 410, OTTAWA, ON Phone: (613)828-7800, Fax: (613)828-2600

**OCSB RIVERSIDE SOUTH ELEMENTARY SCHOOL**  
**Solarium & Brian Good, ONTARIO**

**FIGURE 1 PRE-DEVELOPMENT DRAINAGE AREAS**

DESIGNED: AS	PROJECT No.: 20-1095D
DRAFTED: RI	REVISION DATE:
CHECKED: AS	APPROVED: AS
SCALE: 1:1000	REVISION No.: 1

**LEGEND**

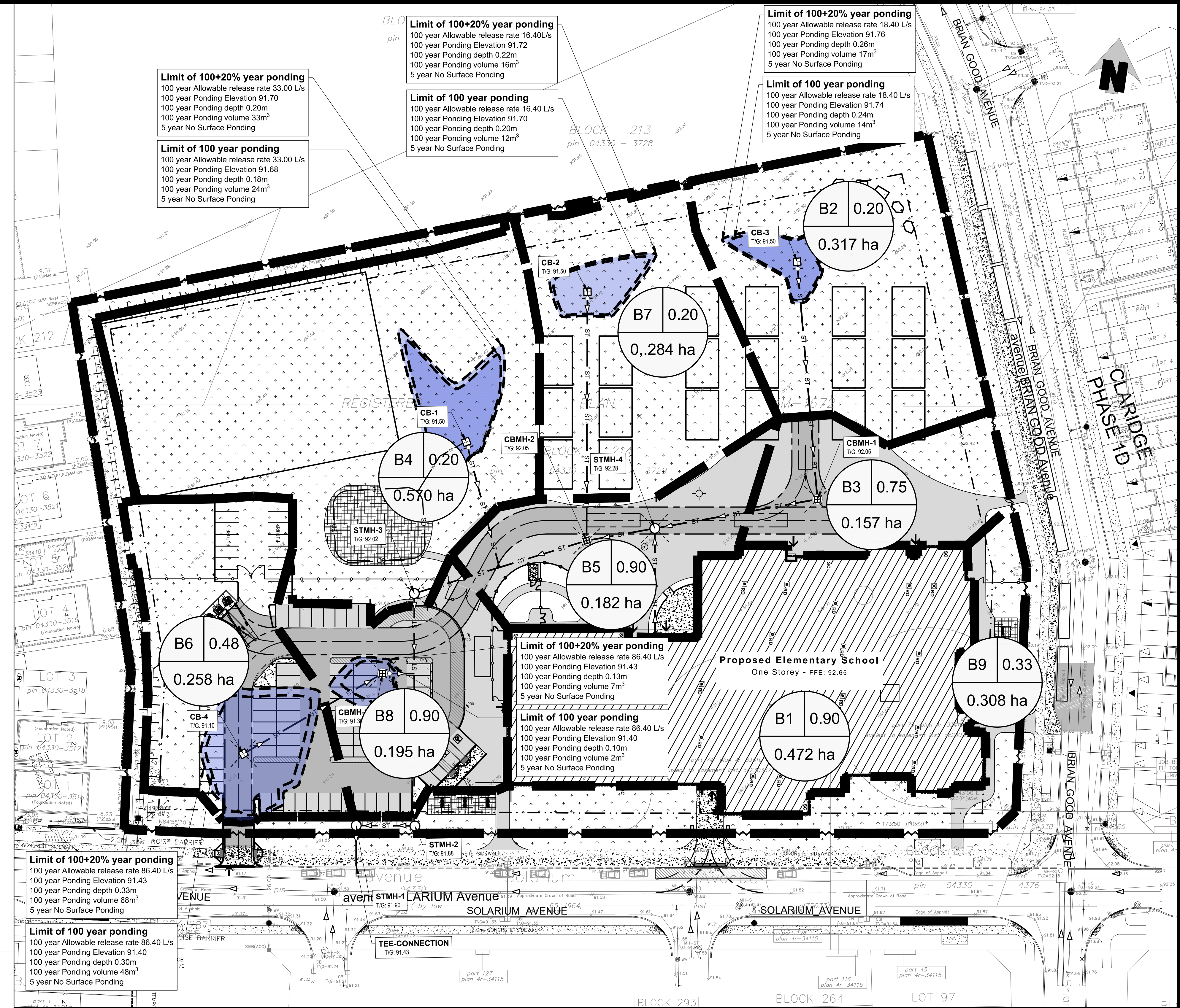
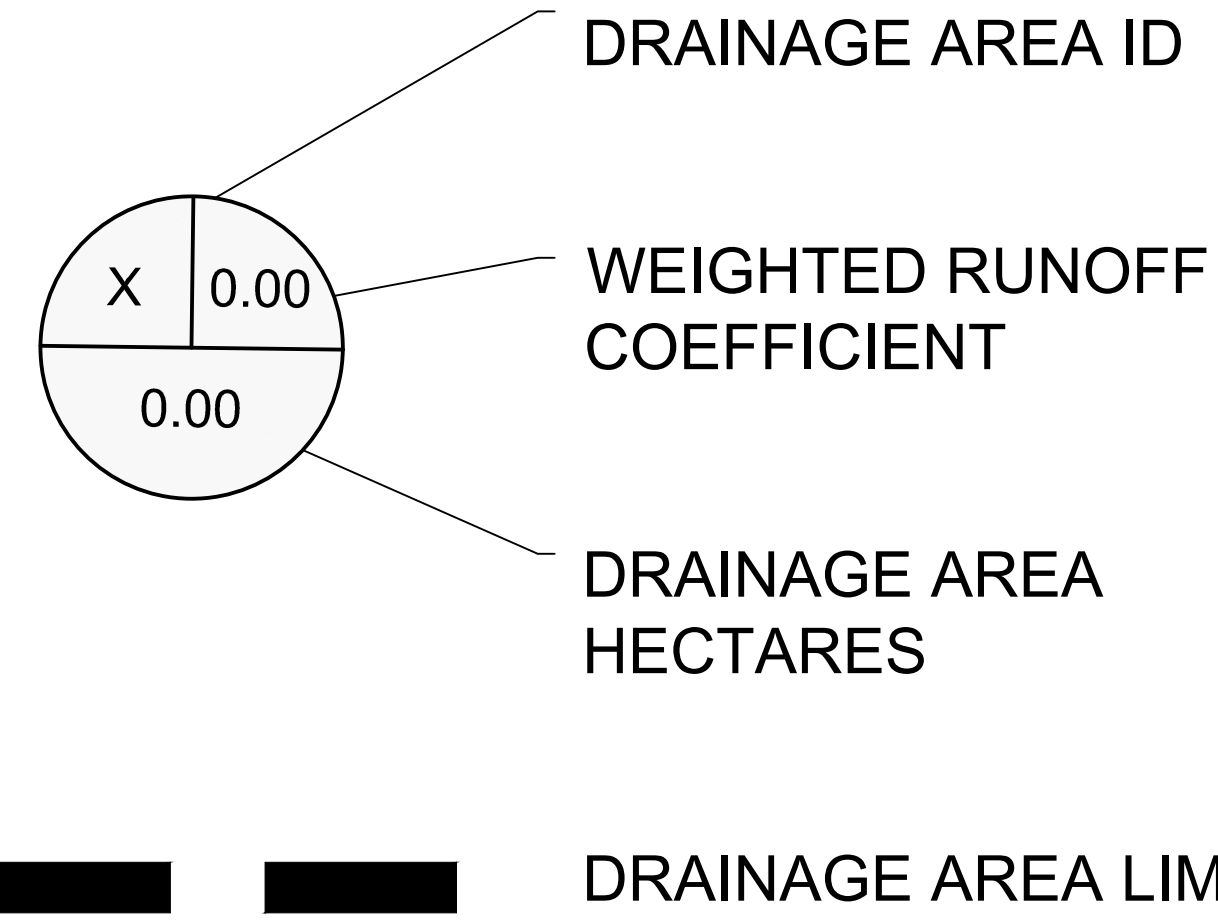

**Jp2g Consultants Inc.**  
 ENGINEERS • PLANNERS • PROJECT MANAGERS

12 INTERNATIONAL DRIVE, PEMBROKE, ON  
 Phone: (613)735-2507, Fax: (613)735-4513

1150 MORRISON DRIVE, SUITE 410, OTTAWA, ON  
 Phone: (613)828-7800, Fax: (613)828-2600

**OCSB RIVERSIDE SOUTH ELEMENTARY SCHOOL**  
 Solarium & Brian Good, ONTARIO

**FIGURE 2 POST-DEVELOPMENT DRAINAGE AREAS**

DESIGNED: AS	PROJECT No.: 20-1095D
DRAFTED: RI	REVISION DATE:
CHECKED: AS	APPROVED: AS
SCALE: 1:1000	REVISION No.: 1

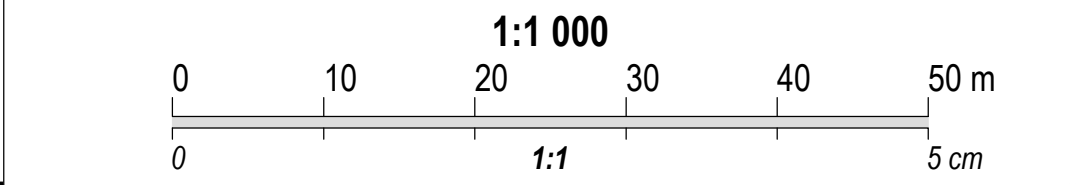
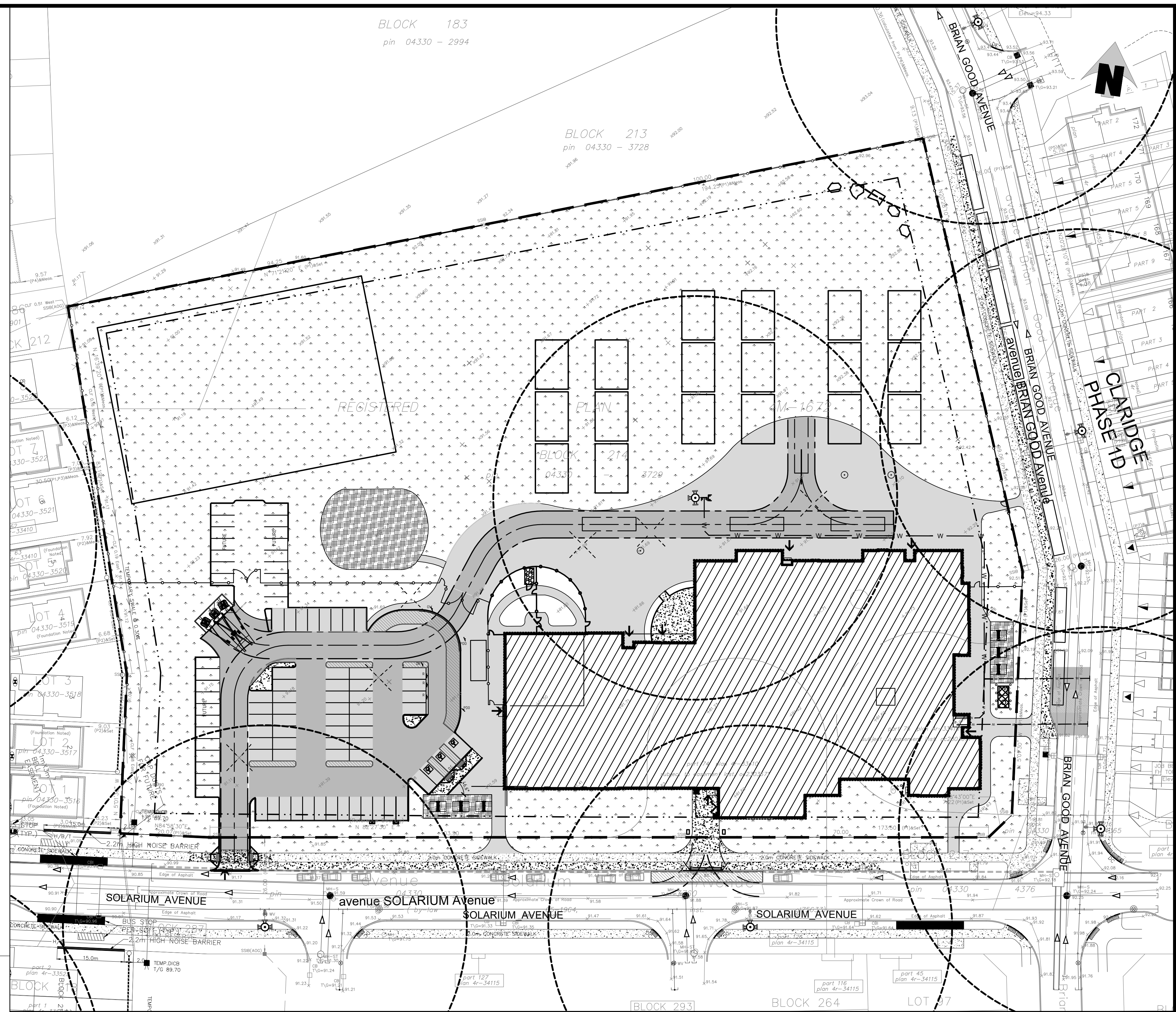
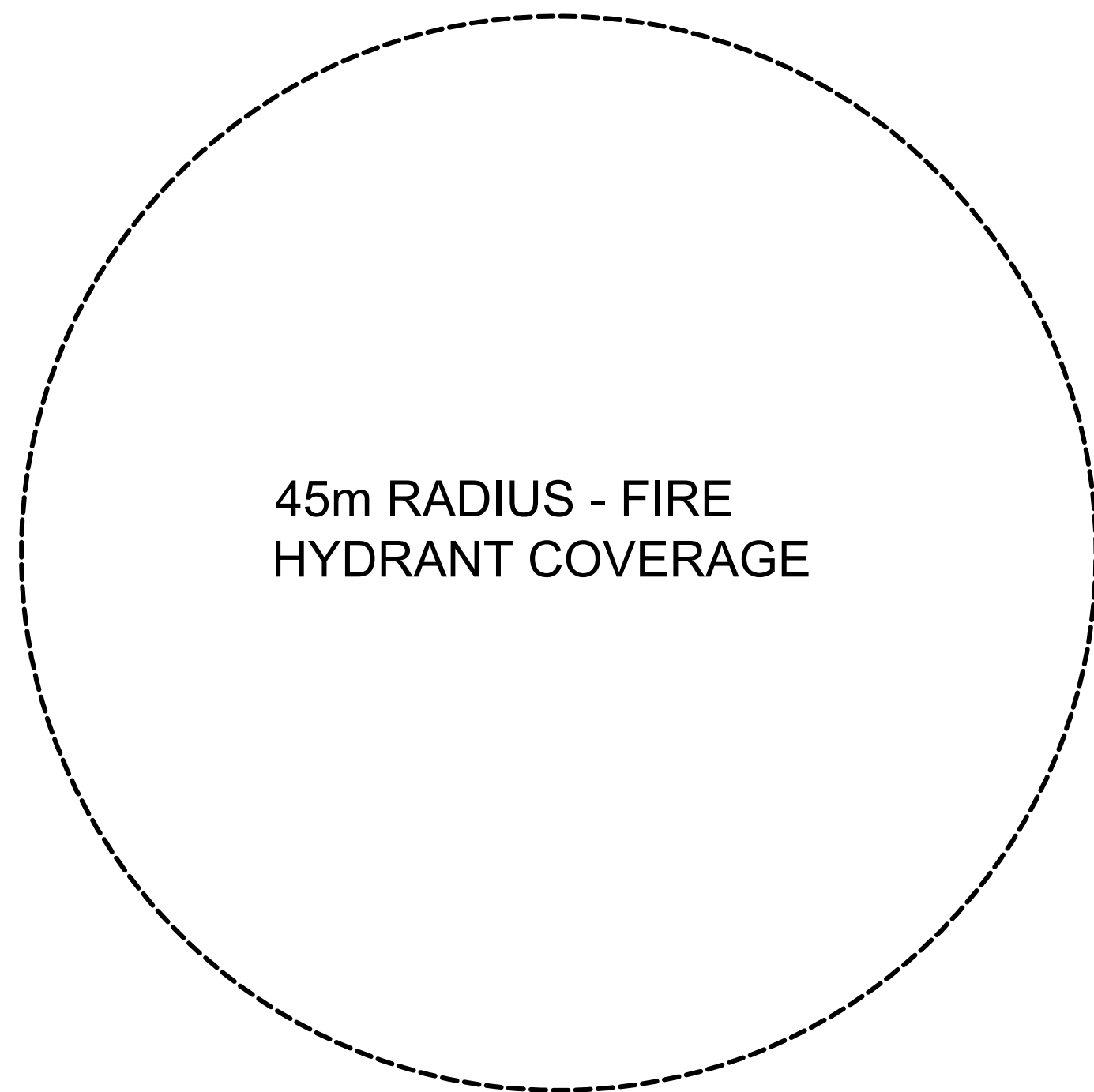

**Jp2g Consultants Inc.**  
ENGINEERS • PLANNERS • PROJECT MANAGERS

12 INTERNATIONAL DRIVE, PEMBROKE, ON  
Phone: (613)735-2507, Fax: (613)735-4513

1150 MORRISON DRIVE, SUITE 410, OTTAWA, ON  
Phone: (613)828-7800, Fax: (613)828-2600

**OCSB RIVERSIDE SOUTH ELEMENTARY SCHOOL**  
**Solarium & Brian Good, ONTARIO**

**FIGURE 3 FIRE HYDRANT COVERAGE AREA**

DESIGNED: AS	PROJECT No.: 20-1095D
DRAFTED: RI	REVISION DATE:
CHECKED: AS	APPROVED: AS
SCALE: 1:1000	REVISION No.: 1



## **Appendix B - Stormwater Management Calculations**

**Appendix B - Storm Sewer Design Sheet**

**B.1.1 - Allowable release rate**

ID	Description	Type	Areas (m <sup>2</sup> )		Total (m <sup>2</sup> )	C <sub>pre-2-yr</sub>
			C <sub>0.90</sub>	C <sub>0.20</sub>		
A	Property Grounds	uncontrolled	0	27422	27422	0.7
			0	27422	27422	

\*including 25% increase as per City of Ottawa Sewer Design Guidelines

Using the data for the site from the preconsultation meeting notes

The maximum allowable release rate allocated for this site is:

Q<sub>allowable (2-year)</sub> = **410** l/s (Provided in pre-consultation notes)  
 Total Area, A = **2.74** ha

Estimated time of concentration, t<sub>c</sub> = **10.0** minutes \*\*\*As per City of Ottawa Sewer Design Guidelines (Section 5.4.5.2)  
 Based on Ottawa IDF curve, i<sub>2-years</sub> = 732.951 / (t<sub>c</sub>+6.199)<sup>0.810</sup>  
**76.8** mm/hr

**B.1.2 - Post-development release rate**

ID	Description	Type	Areas (m <sup>2</sup> )		Total (m <sup>2</sup> )	C <sub>post-5-yr</sub>	C <sub>post-100-yr</sub> <sup>+</sup>
			C <sub>0.90</sub>	C <sub>0.20</sub>			
B1	New School Building Roof	controlled	4721	0	4721	0.90	1.00
B6	CB-4 catchment	controlled	1016	1566	2582	0.48	0.55
B8	CBMH-3 Catchment	controlled	1949	0	1949	0.90	1.00
B4	CB-1 Catchment	controlled	0	5700	5700	0.20	0.25
B5	CBMH-2 catchment	uncontrolled	1820	0	1820	0.90	1.00
B7	CB-2 catchment	controlled	0	2836	2836	0.20	0.25
B3	CBMH-1 catchment	uncontrolled	1226	343	1569	0.75	0.84
B2	CB-3 catchment	controlled	0	3165	3165	0.20	0.25
B9	Overland fronts	uncontrolled	566	2515	3081	0.33	0.39
			<b>11297</b>	<b>16125</b>	<b>27422</b>	<b>0.40</b>	<b>0.47</b>

\*including 25% increase as per City of Ottawa Sewer Design Guidelines

Calculations for post-development runoff coefficient

C<sub>post-5-yr (col. D)</sub> = (column A \* 0.9 + column B \* 0.2) / column C  
 C<sub>post-100-yr (col. E)</sub> = (column A \* 1.0 + column B \* 0.2\*1.25) / column C  
 Note: 0.90 x 1.25 = 1.125, use max. 1.0

Calculations for average weighted runoff coefficient

C<sub>post-5-yr</sub> = 0.40  
 C<sub>post-100-yr</sub> = 0.47

Estimated time of concentration, t<sub>c</sub> = **10.0** minutes \*\*\*As per City of Ottawa Sewer Design Guidelines (Section 5.4.5.2)  
 Based on Ottawa IDF curve, i<sub>5-years</sub> = 998.071 / (t<sub>c</sub>+6.053)<sup>0.814</sup>  
**104.2** mm/hr  
 Based on Ottawa IDF curve, i<sub>100-years</sub> = 1735.688 / (t<sub>c</sub>+6.014)<sup>0.820</sup>  
**178.6** mm/hr

**B.1.2.1a - Uncontrolled Overland Surface Flow**

Uncontrolled area, Overland Fronts **0.308** ha  
 5-year Runoff coefficient, i<sub>5-yr-uncontrolled</sub> **0.33**  
 100-year Runoff coefficient, i<sub>100-yr-uncontrolled</sub> **0.39**  
 Uncontrolled overland surface Release Rate 5-year **29.3** l/s **A**  
 Uncontrolled overland surface Release Rate 100-year **59.3** l/s **B**

**B.1.2.1b - Uncontrolled Network Flow**

B3 Uncontrolled CBMH-1 **0.157** ha  
 5-year Runoff coefficient, i<sub>5-yr-uncontrolled</sub> **0.75**  
 100-year Runoff coefficient, i<sub>100-yr-uncontrolled</sub> **0.84**  
 Uncontrolled overland surface Release Rate 5-year **33.9** l/s **C**  
 Uncontrolled overland surface Release Rate 100-year **65.1** l/s **D**  
 B5 Uncontrolled CBMH-2 **0.182** ha  
 5-year Runoff coefficient, i<sub>5-yr-uncontrolled</sub> **0.90**  
 100-year Runoff coefficient, i<sub>100-yr-uncontrolled</sub> **1.00**  
 Uncontrolled overland surface Release Rate 5-year **47.4** l/s **E**  
 Uncontrolled overland surface Release Rate 100-year **90.3** l/s **F**  
 Total uncontrolled Network Flow 5-year **81.4** l/s **C+E**  
 Total uncontrolled Network Flow 100-year **155.4** l/s **D+F**

**B.1.2.2 - Allowable release rate for Controlled network flow**

Total uncontrolled flow ( surface + network) 5 year **110.7** l/s **A+C+E**  
 Total uncontrolled flow ( surface + network) 100 year **214.7** l/s **B+D+F**  
 Q<sub>net-allowable 5-year</sub> = **299.2** l/s  
 \*Q<sub>net-allowable 100-year</sub> = **195.1** l/s **G : Must be controlled to net-allowable 100-year**  
 Accordingly, the allowable uncontrolled ( 5 year) + controlled flow in network is **276.5** l/s **G+C+E** (see storm sewer design sheet)  
 Accordingly, the allowable uncontrolled ( 100 year) + controlled flow in network is **350.6** l/s

**B.1.3 - Post-development onsite storage**

**B.1.3.1 - Estimated detention Roof B1**

Area **0.472** ha  
 5-year Runoff coefficient **0.90**  
 100-year Runoff coefficient **1.00**  
 Roof Drains **39.69** l/s 21 roof drains at 30 GPM at 6" head, each drain = 1.89 l/s at 150mm head (scuppers level)

**Table 1.3.1a - 5-year estimated detention Building Roof**

	Time (minutes)	I <sub>5-years</sub> (mm/hr)	Q <sub>actual</sub> (l/s)	Q <sub>allowable</sub> (l/s)	Q <sub>stored</sub> (l/s)	V <sub>stored</sub> (m <sup>3</sup> )
	10	104.2	123.1	39.7	83.4	50.0
peak V <sub>stored</sub> →	15	83.6	98.7	39.7	59.0	53.1
	20	70.3	83.0	39.7	43.3	51.9
	25	60.9	71.9	39.7	32.2	48.4
	30	53.9	63.7	39.7	24.0	43.2
	35	48.5	57.3	39.7	17.6	37.0
	40	44.2	52.2	39.7	12.5	30.0
	45	40.6	48.0	39.7	8.3	22.4
	50	37.7	44.5	39.7	4.8	14.4
	55	35.1	41.5	39.7	1.8	5.9
	60	32.9	38.9	39.7	-0.8	-2.8
Therefore		<b>53</b>	<b>m<sup>3</sup> estimated roof detention</b>			

**Table 1.3.1b - 100-year estimated detention Building Roof**

	Time (min)	I <sub>100-years</sub> (mm/hr)	Q <sub>actual</sub> (l/s)	Q <sub>allowable</sub> (l/s)	Q <sub>stored</sub> (l/s)	V <sub>stored</sub> (m <sup>3</sup> )
	10	178.6	234.3	39.7	194.7	116.8
	15	142.9	187.5	39.7	147.8	133.1
	20	120.0	157.4	39.7	117.7	141.3
peak V <sub>stored</sub> →	25	103.8	136.3	39.7	96.6	144.9
	30	91.9	120.6	39.7	80.9	145.6
	35	82.6	108.4	39.7	68.7	144.2
	40	75.1	98.6	39.7	58.9	141.4
	45	69.1	90.6	39.7	50.9	137.5
	50	64.0	83.9	39.7	44.2	132.7
	55	59.6	78.3	39.7	38.6	127.3
	60	55.9	73.4	39.7	33.7	121.2
Therefore		<b>146</b>	<b>m<sup>3</sup> estimated yard detention</b>			

**B.1.3.2 - Estimated detention CB-4 +CBMH-3 (surface Storage) B6+B8 Parking Lot**

Area **0.453** ha  
 5-year Runoff coefficient **0.66**  
 100-year Runoff coefficient **0.74**  
 Install flow control downstream in CBMH-3 **86.40** l/s

**Table 1.3.2a - 5-year estimated detention in Parking and West School Yard**

	Time (minutes)	I <sub>5-years</sub> (mm/hr)	Q <sub>actual</sub> (l/s)	Q <sub>allowable</sub> (l/s)	Q <sub>stored</sub> (l/s)	V <sub>stored</sub> (m <sup>3</sup> )
	10	104.2	86.4	86.4	0.0	0.0
peak V <sub>stored</sub> →	15	83.6	69.3	86.4	-17.1	-15.4
	20	70.3	58.2	86.4	-28.2	-33.8
	25	60.9	50.5	86.4	-35.9	-53.9
	30	53.9	44.7	86.4	-41.7	-75.1
	35	48.5	40.2	86.4	-46.2	-97.0
	40	44.2	36.6	86.4	-49.8	-119.5
	45	40.6	33.7	86.4	-52.7	-142.4
	50	37.7	31.2	86.4	-55.2	-165.6
	55	35.1	29.1	86.4	-57.3	-189.0
	60	32.9	27.3	86.4	-59.1	-212.7
Therefore		<b>0</b>	<b>m<sup>3</sup> estimated yard detention</b>			



**Table 1.3.2b - 100-year estimated detention in Parking and West School Yard**

Time (min)	$I_{100\text{-years}}$ (mm/hr)	$Q_{\text{actual}}$ (l/s)	$Q_{\text{allowable}}$ (l/s)	$Q_{\text{stored}}$ (l/s)	$V_{\text{stored}}$ (m <sup>3</sup> )
10	178.6	166.6	86.4	80.2	48.1
15	142.9	133.3	86.4	46.9	42.2
20	120.0	111.9	86.4	25.5	30.6
25	103.8	96.9	86.4	10.5	15.7
30	91.9	85.7	86.4	-0.7	-1.2
35	82.6	77.0	86.4	-9.4	-19.6
40	75.1	70.1	86.4	-16.3	-39.1
45	69.1	64.4	86.4	-22.0	-59.3
50	64.0	59.7	86.4	-26.7	-80.2
55	59.6	55.6	86.4	-30.8	-101.5
60	55.9	52.2	86.4	-34.2	-123.3

Therefore **48** m<sup>3</sup> estimated yard detention

**Table 1.3.2b - 100-year (+ 20%) estimated detention in Parking and West School Yard (surface Storage)**

Time (min)	$I_{100\text{-years} \times 120\%}$ (mm/hr)	$Q_{\text{actual}}$ (l/s)	$Q_{\text{allowable}}$ (l/s)	$Q_{\text{stored}}$ (l/s)	$V_{\text{stored}}$ (m <sup>3</sup> )
10	214.3	199.9	86.4	113.5	68.1
15	171.5	160.0	86.4	73.6	66.2
20	143.9	134.3	86.4	47.9	57.5
25	124.6	116.3	86.4	29.9	44.8
30	110.2	102.9	86.4	16.5	29.6
35	99.1	92.5	86.4	6.1	12.7
40	90.2	84.1	86.4	-2.3	-5.4
45	82.9	77.3	86.4	-9.1	-24.5
50	76.7	71.6	86.4	-14.8	-44.4
55	71.5	66.8	86.4	-19.6	-64.8
60	67.1	62.6	86.4	-23.8	-85.7

Therefore **68** m<sup>3</sup> estimated yard detention

**B.1.3.5 - Estimated detention CB-1 (Surface Storage) B4**

Total controlled Area **0.570** ha  
 5-year Runoff coefficient **0.20**  
 100-year Runoff coefficient **0.25**  
 Install flow control at CB-1 **33.00** l/s

**Table 1.3.4a - 5-year estimated detention North West Soccer Field**

Time (minutes)	$I_{5\text{-years}}$ (mm/hr)	$Q_{\text{actual}}$ (l/s)	$Q_{\text{allowable}}$ (l/s)	$Q_{\text{stored}}$ (l/s)	$V_{\text{stored}}$ (m <sup>3</sup> )
10	104.2	33.0	33.0	0.0	0.0
15	83.6	26.5	33.0	-6.5	-5.9
20	70.3	22.3	33.0	-10.7	-12.9
25	60.9	19.3	33.0	-13.7	-20.6
30	53.9	17.1	33.0	-15.9	-28.6
35	48.5	15.4	33.0	-17.6	-37.0
40	44.2	14.0	33.0	-19.0	-45.6
45	40.6	12.9	33.0	-20.1	-54.3
50	37.7	11.9	33.0	-21.1	-63.2
55	35.1	11.1	33.0	-21.9	-72.2
60	32.9	10.4	33.0	-22.6	-81.2

Therefore **0** m<sup>3</sup> estimated yard detention

**Table 1.3.4b - 100-year estimated detention North Soccer Field (underground Storage)**

Time (min)	$I_{100\text{-years}}$ (mm/hr)	$Q_{\text{actual}}$ (l/s)	$Q_{\text{allowable}}$ (l/s)	$Q_{\text{stored}}$ (l/s)	$V_{\text{stored}}$ (m <sup>3</sup> )
10	178.6	70.7	33.0	37.7	22.6
15	142.9	56.6	33.0	23.6	21.2
20	120.0	47.5	33.0	14.5	17.4
25	103.8	41.1	33.0	8.1	12.2
30	91.9	36.4	33.0	3.4	6.1
35	82.6	32.7	33.0	-0.3	-0.6
40	75.1	29.8	33.0	-3.2	-7.8
45	69.1	27.4	33.0	-5.6	-15.2
50	64.0	25.3	33.0	-7.7	-23.0
55	59.6	23.6	33.0	-9.4	-31.0
60	55.9	22.1	33.0	-10.9	-39.1

Therefore **23** m<sup>3</sup> estimated yard detention

**Table 1.3.4b - 100-year (+ 20%) estimated detention North Soccer Field (underground Storage)**

Time (min)	$I_{100\text{-years}}$ (mm/hr)	$Q_{\text{actual}}$ (l/s)	$Q_{\text{allowable}}$ (l/s)	$Q_{\text{stored}}$ (l/s)	$V_{\text{stored}}$ (m <sup>3</sup> )
10	214.3	84.9	33.0	51.9	31.1
15	171.5	67.9	33.0	34.9	31.4
20	143.9	57.0	33.0	24.0	28.8
25	124.6	49.4	33.0	16.4	24.5
30	110.2	43.7	33.0	10.7	19.2
35	99.1	39.3	33.0	6.3	13.1
40	90.2	35.7	33.0	2.7	6.5
45	82.9	32.8	33.0	-0.2	-0.5
50	76.7	30.4	33.0	-2.6	-7.8
55	71.5	28.3	33.0	-4.7	-15.4
60	67.1	26.6	33.0	-6.4	-23.1

Therefore **31** m<sup>3</sup> estimated yard detention

**B.1.3.6 - Estimated detention CB-2 ( surface Storage) BZ**

Total controlled Area **0.284** ha

5-year Runoff coefficient **0.20**  
 100-year Runoff coefficient **0.25**  
 Install flow control after CB-2 **16.40** l/s

**Table 1.3.4a - 5-year estimated detention in Middle Rear Yard**

	Time (minutes)	$i_{5\text{-years}}$ (mm/hr)	$Q_{\text{actual}}$ (l/s)	$Q_{\text{allowable}}$ (l/s)	$Q_{\text{stored}}$ (l/s)	$V_{\text{stored}}$ (m <sup>3</sup> )
peak $V_{\text{stored}}$ →	10	104.2	16.4	16.4	0.0	0.0
	15	83.6	13.2	16.4	-3.2	-2.9
	20	70.3	11.1	16.4	-5.3	-6.4
	25	60.9	9.6	16.4	-6.8	-10.2
	30	53.9	8.5	16.4	-7.9	-14.2
	35	48.5	7.7	16.4	-8.7	-18.4
	40	44.2	7.0	16.4	-9.4	-22.6
	45	40.6	6.4	16.4	-10.0	-27.0
	50	37.7	5.9	16.4	-10.5	-31.4
	55	35.1	5.5	16.4	-10.9	-35.8
	60	32.9	5.2	16.4	-11.2	-40.3

Therefore **0** m<sup>3</sup> estimated yard detention

**Table 1.3.4b - 100-year estimated detention in Parking Area (surface + underground Storage)**

	Time (min)	$i_{100\text{-years}}$ (mm/hr)	$Q_{\text{actual}}$ (l/s)	$Q_{\text{allowable}}$ (l/s)	$Q_{\text{stored}}$ (l/s)	$V_{\text{stored}}$ (m <sup>3</sup> )
peak $V_{\text{stored}}$ →	10	178.6	35.2	16.4	18.8	11.3
	15	142.9	28.2	16.4	11.8	10.6
	20	120.0	23.6	16.4	7.2	8.7
	25	103.8	20.5	16.4	4.1	6.1
	30	91.9	18.1	16.4	1.7	3.1
	35	82.6	16.3	16.4	-0.1	-0.3
	40	75.1	14.8	16.4	-1.6	-3.8
	45	69.1	13.6	16.4	-2.8	-7.5
	50	64.0	12.6	16.4	-3.8	-11.4
	55	59.6	11.8	16.4	-4.6	-15.3
	60	55.9	11.0	16.4	-5.4	-19.4

Therefore **11** m<sup>3</sup> estimated yard detention

**Table 1.3.4b - 100-year (+ 20%) estimated detention in Parking Area (surface + underground Storage)**

	Time (min)	$i_{100\text{-years}}$ (mm/hr)	$Q_{\text{actual}}$ (l/s)	$Q_{\text{allowable}}$ (l/s)	$Q_{\text{stored}}$ (l/s)	$V_{\text{stored}}$ (m <sup>3</sup> )
peak $V_{\text{stored}}$ →	10	214.3	42.2	16.4	25.8	15.5
	15	171.5	33.8	16.4	17.4	15.7
	20	143.9	28.4	16.4	12.0	14.4
	25	124.6	24.6	16.4	8.2	12.2
	30	110.2	21.7	16.4	5.3	9.6
	35	99.1	19.5	16.4	3.1	6.6
	40	90.2	17.8	16.4	1.4	3.3
	45	82.9	16.3	16.4	-0.1	-0.2
	50	76.7	15.1	16.4	-1.3	-3.8
	55	71.5	14.1	16.4	-2.3	-7.6
	60	67.1	13.2	16.4	-3.2	-11.4

Therefore **16** m<sup>3</sup> estimated yard detention

**B.1.3.7 - Estimated detention CB-3 (Surface Storage) B2**

Area **0.316** ha  
 5-year Runoff coefficient **0.20**  
 100-year Runoff coefficient **0.25**  
 Install flow control after CB-3 **18.40** l/s

**Table 1.3.2a - 5-year estimated detention East Rear Yard**

	Time (minutes)	$i_{5\text{-years}}$ (mm/hr)	$Q_{\text{actual}}$ (l/s)	$Q_{\text{allowable}}$ (l/s)	$Q_{\text{stored}}$ (l/s)	$V_{\text{stored}}$ (m <sup>3</sup> )
peak $V_{\text{stored}}$ →	10	104.2	18.3	18.4	-0.1	0.0
	15	83.6	14.7	18.4	-3.7	-3.3
	20	70.3	12.4	18.4	-6.0	-7.2
	25	60.9	10.7	18.4	-7.7	-11.5
	30	53.9	9.5	18.4	-8.9	-16.0
	35	48.5	8.5	18.4	-9.9	-20.7
	40	44.2	7.8	18.4	-10.6	-25.5
	45	40.6	7.1	18.4	-11.3	-30.4
	50	37.7	6.6	18.4	-11.8	-35.3
	55	35.1	6.2	18.4	-12.2	-40.3
	60	32.9	5.8	18.4	-12.6	-45.4

Therefore **0** m<sup>3</sup> estimated yard detention

**Table 1.3.2b - 100-year estimated detention East Soccer Field (underground Storage)**

	Time (min)	$i_{100\text{-years}}$ (mm/hr)	$Q_{\text{actual}}$ (l/s)	$Q_{\text{allowable}}$ (l/s)	$Q_{\text{stored}}$ (l/s)	$V_{\text{stored}}$ (m <sup>3</sup> )
peak $V_{\text{stored}}$ →	10	178.6	39.3	18.4	20.9	12.5
	15	142.9	31.4	18.4	13.0	11.7
	20	120.0	26.4	18.4	8.0	9.6
	25	103.8	22.8	18.4	4.4	6.7
	30	91.9	20.2	18.4	1.8	3.3
	35	82.6	18.2	18.4	-0.2	-0.5
	40	75.1	16.5	18.4	-1.9	-4.5
	45	69.1	15.2	18.4	-3.2	-8.7
	50	64.0	14.1	18.4	-4.3	-13.0
	55	59.6	13.1	18.4	-5.3	-17.4
	60	55.9	12.3	18.4	-6.1	-22.0

Therefore **13** m<sup>3</sup> estimated yard detention

**Table 1.3.2b - 100-year (+ 20%) estimated detention East Soccer Field (underground Storage)**

	Time (min)	$i_{100\text{-years}}$ (mm/hr)	$Q_{\text{actual}}$ (l/s)	$Q_{\text{allowable}}$ (l/s)	$Q_{\text{stored}}$ (l/s)	$V_{\text{stored}}$ (m <sup>3</sup> )
peak $V_{\text{stored}} \rightarrow$	10	214.3	47.1	18.4	28.7	17.2
	15	171.5	37.7	18.4	19.3	17.4
	20	143.9	31.7	18.4	13.3	15.9
	25	124.6	27.4	18.4	9.0	13.5
	30	110.2	24.2	18.4	5.8	10.5
	35	99.1	21.8	18.4	3.4	7.1
	40	90.2	19.8	18.4	1.4	3.4
	45	82.9	18.2	18.4	-0.2	-0.5
	50	76.7	16.9	18.4	-1.5	-4.6
	55	71.5	15.7	18.4	-2.7	-8.8
	60	67.1	14.8	18.4	-3.6	-13.1

Therefore **17** m<sup>3</sup> estimated yard detention

#### B.1.4 - Site storage

	required (m3)			Ponding depth (m)	Available (m3)	
	5-year required (m3)	100-year required (m3)	100+20%-year required (m3)		Ponding area (m2)	Surface Available (m3)
<b>100+20% year storage / ponding depth</b>						
Roof Detention ( B1) surface	53			0.15	4721	236
CB-4 and CBMH-3 Parking and West School Yard B6+B8 Parking Lot	0		68	0.33	554	68
CB-1 North West Soccer Field B4	0		31	0.20	491	33
CB-2 Middle Rear Yard B7	0		16	0.22	222	16
CB-3 East Rear Yard B2	0		17	0.26	200	17

( add 7cum storage over rim level of CBMH3)

	required (m3)			Ponding depth (m) 100 year	Ponding area (m2)	Surface Available (m3)
	5-year required (m3)	100-year required (m3)	100+20%-year required (m3)			
<b>100 year storage / ponding depth</b>						
Roof Detention ( B1) surface	53	146		0.15	4721.00	236
CB-4 and CBMH-3 Parking and West School Yard	0	48		0.30	464	48
CB-1 North West Soccer Field	0	23		0.18	397	24
CB-2 Middle Rear Yard	0	11		0.20	183	12
CB-3 East Rear Yard	0	13		0.24	172	14

( add 2cum storage over rim level of CBMH3)



**B.1.5 - Storm Sewer Pipe Design ( 5 YEARS)**

<u>Definitions</u>		<u>Rational Method</u>	<u>Notes</u>
Manning's Coefficient =	0.013	Q = 2.78 CIA (l/s), where	1) Used City of Ottawa IDF Curve
Return Frequency (yrs) =	5	C= Runoff Coefficient	2) Min. velocity = 0.8 m/sec
1 acre = 0.4047 hectares		i = Rainfall Intensity (mm/hr)	3) Max. velocity = 6.0 m/sec
		A = Areas in Hectares (ha)	

LOCATION		AREA (ha)		Total	FLOW				SEWER DATA									
From	To	C=	C=	C=	Individual	Cum.	tc	i <sub>5 years</sub>	Flow <sub>5 years</sub>	Dia.	Slope	Length	Capacity	Velocity	Sect. Time	Tot. Time	Utilization	
		0.90	0.20	1.10	2.78CA	2.78CA	(min.)	(mm/hr)	(l/s)	(mm)	(%)	(m)	(full) (l/s)	(full) (m/s)	(minutes)	(minutes)	(%)	
CB-3	CBMH-1	ICD						10.0	104.2	18.4	300	0.53	53.2	70.4	1.0	0.9	10.9	26
CBMH-1	STMH-4	0.123	0.034	0.16	0.326	0.326	10.0	104.2	52.3	375	0.50	36.8	124.0	1.1	0.5	10.5	42	
ROOF DRAINS	STMH-4	ROOF DRAINS						10.0	104.2	39.7	300	1.90	23.7	133.3	1.9	0.2	10.2	30
STMH-4	CBMH-2	ICD						10.5	101.4	92.0	450	0.50	15.4	201.6	1.3	0.2	10.7	46
CB-2	CBMH-2	ICD						10.0	104.2	16.4	300	1.32	55.5	111.1	1.6	0.6	10.6	15
CBMH-2	NODE	0.182	0.000	0.182	0.455		10.0	104.2	155.9	450	1.00	20.4	285.1	1.8	0.2	10.2	55	
CB-1	NODE	ICD						10.0	104.2	33.0	300	3.00	29.0	167.5	2.4	0.2	10.2	20
NODE	STMH-3	ICD						11.6	96.4	188.9	450	1.00	20.2	285.1	1.8	0.2	11.8	66
STMH-3	NODE	ICD						10.2	103.2	188.9	450	2.00	16.4	403.2	2.5	0.1	10.3	47
CB-4	CBMH-3	0.102	0.157	0.258	0.341		10.0	104.2	60.9	300	2.10	35.8	140.1	2.0	0.3	10.3	43	
CBMH-3	NODE	ICD						10.3	102.6	86.4	300	2.50	6.0	152.9	2.2	0.0	10.3	57
NODE	STMH-2	ICD						10.3	102.6	275.3	450	2.00	34.0	403.2	2.5	0.2	10.5	68
STMH-2	STMH-1	ICD						10.5	101.5	275.3	450	2.50	13.0	450.8	2.8	0.1	10.6	61
STMH-1	SOLARIUM	ICD						10.6	101.1	275.3	450	2.50	11.9	450.8	2.8	0.1	10.7	61

ICD / Roof drain Flow control installed

<b>Controlled l/s</b>	193.9	less than	195.1	(OK)
<b>Total controlled + uncontrolled in network l/s</b>	275.3	less than	276.5	(OK)

Orifice Diameter Calculation



**Design Parameters\***

Pipe Area Formula:  $A = Q / (C(2gh)^{0.5})$

Pipe Diameter Formula:  $A = (\pi \cdot d^2) / 4$   
 $d = \sqrt{(4 \cdot A / \pi)}$

d = Orifice diameter (m)

A = Pipe area (m<sup>2</sup>)

C = 0.61

g = 9.81 (m/s<sup>2</sup>)

h = head of ponding from the centroid of the pipe invert (m)

Q = Max. flow through pipe (l/s)

**CBMH-3**

Elevation at Top of Ponding	Elevation at Pipe Invert	Size of Outlet Pipe	Head from Centroid (h)
(m)	(m)	(mm)	(m)
91.43	89.10	300.0	2.180

Max Flow (Q)	Coefficient (C)	g	Head from Centroid (h)	Pipe Area (A)	Orifice Diameter (d)	Orifice Diameter (d)
(l/s)	-	(m/s <sup>2</sup> )	(m)	(m <sup>2</sup> )	m	mm
86.4	0.61	9.8	2.18	0.022	0.166	166

**CB-1**

Elevation at Top of Ponding	Elevation at Pipe Invert	Size of Outlet Pipe	Head from Centroid (h)
(m)	(m)	(mm)	(m)
91.70	90.45	300.0	1.100

Max Flow (Q)	Coefficient (C)	g	Head from Centroid (h)	Pipe Area (A)	Orifice Diameter (d)	Orifice Diameter (d)
(l/s)	-	(m/s <sup>2</sup> )	(m)	(m <sup>2</sup> )	m	mm
33.0	0.61	9.8	1.10	0.012	0.122	122

**CB-2**

Elevation at Top of Ponding	Elevation at Pipe Invert	Size of Outlet Pipe	Head from Centroid (h)
(m)	(m)	(mm)	(m)
91.72	90.45	300.0	1.120

Max Flow (Q)	Coefficient (C)	g	Head from Centroid (h)	Pipe Area (A)	Orifice Diameter (d)	Orifice Diameter (d)
(l/s)	-	(m/s <sup>2</sup> )	(m)	(m <sup>2</sup> )	m	mm
16.4	0.61	9.8	1.12	0.006	0.085	85

**CB-3**

Elevation at Top of Ponding	Elevation at Pipe Invert	Size of Outlet Pipe	Head from Centroid (h)
(m)	(m)	(mm)	(m)
91.76	90.45	300.0	1.160

Max Flow (Q)	Coefficient (C)	g	Head from Centroid (h)	Pipe Area (A)	Orifice Diameter (d)	Orifice Diameter (d)
(l/s)	-	(m/s <sup>2</sup> )	(m)	(m <sup>2</sup> )	m	mm
18.4	0.61	9.8	1.16	0.006	0.090	90



## **Appendix C - Sanitary Servicing Calculations**

Appendix C - Sanitary Sewer Design Sheet

C.1.1 - Peak Flow Design Based on Site Area

Definitions

Manning's Coefficient (n) = 0.013

Manning's Formula

$Q = A \cdot R^{2/3} \cdot S^{1/2} / n$  (l/s), where

A = Areas in Hectares (ha)

R = Hydraulic Radius (m)

S = Slope

Design Parameters\*

1) Average Daily Flow = 280 L/p/day

2) Commercial/Institutional Flow = 28,000 L/ha/day

3) Maximum Residential Peak Factor = 4

4) Commercial/Institutional Peak Factor = 1.50

5) Extraneous Flow = 0.33L/s/ha

6) Minimum Velocity = 0.6 m/s

Designed RI

Checked AS

Location			Residential Flow							Institutional Flow				Infiltration Flow		Total Flow		Sewer Data					
Note	From	To	Area (ha)	Units	Population	Cumulative		Average Flow (l/s)	Peak Flow (l/s)	Area (ha)		Average Flow (l/s)	Peak Flow (l/s)	Area (ha)		Inf. Flow (l/s)	Average Flow (l/s)	Peak Flow (l/s)	Dia. (mm)	Slope	Capacity (full) (l/s)	Velocity (full) (m/s)	Utilization (%)
						Area	Population			Individual	Cumulative			Individual	Cumulative								
School	School	SAMH-1	0.00	0	0	0.00	0	0.00	0.00	2.74	2.74	0.89	1.33	2.74	2.74	0.90	1.79	2.24	200	1.00%	32.8	1.0	6.8
School	SAMH-1	SAMH-2	0.00	0	0	0.00	0	0.00	0.00	2.74	2.74	0.89	1.33	2.74	2.74	0.90	1.79	2.24	200	1.00%	32.8	1.0	6.8
School	SAMH-2	SAMH-3	0.00	0	0	0.00	0	0.00	0.00	2.74	2.74	0.89	1.33	2.74	2.74	0.90	1.79	2.24	200	1.00%	32.8	1.0	6.8
Municipal Connection	SAMH-3	Ex. MH																2.24	200	5.60%	77.6	2.5	2.9

\* City of Ottawa Sewer Design Guidelines, Section 4 - Sanitary Sewer Systems



## **Appendix D - Fire Flow Demand Calculations**



**Appendix D- Fire Flow Demand Requirements**

**D.1.1 - Fire Flow Demand Requirements (Fire Underwriters Survey (FUS Guidelines))**

**Fire Flow Formula**

Estimated Fire Flow Formula:  $F=220 \cdot C \cdot A^{1/2}$  (L/min)

- F = Required fire flow (L/min)
- C = Coefficient related to the type of construction
- C<sub>1.5</sub> = 1.5 for wood frame construction
- C<sub>1.0</sub> = 1.0 for ordinary construction
- C<sub>0.8</sub> = 0.8 for non-combustible construction
- C<sub>0.6</sub> = 0.6 for fire-resistive construction
- A = Total floor area in square metres

Designed  
Checked  
Dwg. Reference C1  
Jp2g project No 20-1095D

**New School Building**

**Design Parameters\***

Type of Building Construction = Type II (Noncombustible)

Floor Area\*\*\* = 4628.3 m<sup>2</sup>

Occupancy and Contents Class Limited combustible

Sprinkler System = Automatic sprinkler system conforming to NFPA standards

Sprinkler Building Coverage = Complete building coverage

Factor of Building Coverage X = 1

Number of Storeys = 1

**Exposure Parameters\***

	West	North	East	South	
Separation Distance =	over 30m	23.8	over 30m	over 30m	m
Length of Exposed Wall =	NA	85.9	NA	NA	m
Length-Height Factor =	NA	85.9	NA	NA	m-storeys (up to a maximum of 5-storeys)

Building Construction	Floor Area***	Coefficient	Adjustments (increases or decreases)										Final Adjusted Fire Flow	Final Adjusted Fire Flow	
			A		B = A +/- %		C = B x %		D = B x %						
			Fire Flow (F)	Occupancy	Sprinkler	Exposure***									
Type II (Noncombustible)	(m <sup>2</sup> )		(L/min)	%	Adjusted Fire Flow(s) (L/min)	%	Fire Adjustment Flow(s) (L/min)	West	North	East	South	Total Exposure	Fire Adjustment Flow(s) (L/min)	E = B - C + D (L/min)**	(L/s)
	4,628.3	0.8	12,000.0	-0.15	10,200.0	50%	5,100.0	0%	10%	0%	0%	10%	1,020.0	6,000.0	100.0

\*Water Supply for Public Protection (Fire Underwriters Survey, 2020).

\*\*\*Including all stories



## **Appendix E - Pre-Consultation & Development Servicing Study Checklist**

## APPLICANT'S STUDY AND PLAN IDENTIFICATION LIST

Legend: **S** indicates that the study or plan is required with application submission.

**A** indicates that the study or plan may be required to satisfy a condition of approval/draft approval.

For information and guidance on preparing required studies and plans refer [here](#):

S/A	ENGINEERING		S/A
S	1. Site Servicing Plan	2. Site Servicing Study / Assessment of Adequacy of Public Services	<input type="checkbox"/>
S	3. Grade Control and Drainage Plan	4. Geotechnical Study	S
<input type="checkbox"/>	5. Composite Utility Plan	6. Groundwater Impact Study	<input type="checkbox"/>
<input type="checkbox"/>	7. Servicing Options Report	8. Wellhead Protection Study	<input type="checkbox"/>
S	9. Transportation Impact Assessment (TIA)	10. Erosion and Sediment Control Plan	S
S	11. Servicing and Storm water Management Report / Brief	12. Hydro geological and Terrain Analysis	<input type="checkbox"/>
<input type="checkbox"/>	13. Hydraulic Water main Analysis	14. Noise Study	S
<input type="checkbox"/>	15. Roadway Modification Functional Design	16. Storm Drainage and Ponding Plan	S

S/A	PLANNING / DESIGN / SURVEY		S/A
<input type="checkbox"/>	17. Draft Plan of Subdivision	18. Plan Showing Layout of Parking Garage	<input type="checkbox"/>
<input type="checkbox"/>	19. Draft Plan of Condominium	20. Planning Rationale	S
S	21. Site Plan	22. Minimum Distance Separation (MDS)	<input type="checkbox"/>
<input type="checkbox"/>	23. Concept Plan Showing Proposed Land Uses and Landscaping	24. Agrology and Soil Capability Study	<input type="checkbox"/>
<input type="checkbox"/>	25. Concept Plan Showing Ultimate Use of Land	26. Cultural Heritage Impact Statement	<input type="checkbox"/>
S	27. Landscape Plan	28. Archaeological Resource Assessment Requirements: <b>S</b> (site plan) <b>A</b> (subdivision, condo)	<input type="checkbox"/>
S	29. Survey Plan	30. Shadow Analysis	<input type="checkbox"/>
S	31. Architectural Building Elevation Drawings (dimensioned)	32. Design Brief	S
<input type="checkbox"/>	33. Wind Analysis		<input type="checkbox"/>

S/A	ENVIRONMENTAL		S/A
S	34. Phase 1 Environmental Site Assessment	35. Impact Assessment of Adjacent Waste Disposal/Former Landfill Site	<input type="checkbox"/>
<input type="checkbox"/>	36. Phase 2 Environmental Site Assessment (depends on the outcome of Phase 1)	37. Assessment of Landform Features	<input type="checkbox"/>
<input type="checkbox"/>	38. Record of Site Condition	39. Mineral Resource Impact Assessment	<input type="checkbox"/>
<input type="checkbox"/>	40. Tree Conservation Report	41. Environmental Impact Statement / Impact Assessment of Endangered Species	<input type="checkbox"/>
<input type="checkbox"/>	42. Mine Hazard Study / Abandoned Pit or Quarry Study	43. Integrated Environmental Review (Draft, as part of Planning Rationale)	<input type="checkbox"/>

S/A	ADDITIONAL REQUIREMENTS		S/A
	44. Applicant's Public Consultation Strategy (may be provided as part of the Planning Rationale)	45. Site Lighting Plan	<input type="checkbox"/>
A	46. Site Lighting Certification Letter		

Meeting Date: July 25, 2022

Application Type: *Site Plan Control*

File Lead (Assigned Planner): Mélanie Gervais

Infrastructure Approvals Project Manager: Eric Harrold

Site Address (Municipal Address): 4720 Spratt (waiting for Solarium address)

\*Preliminary Assessment: 1  2  3  4  5

\*One (1) indicates that considerable major revisions are required before a planning application is submitted, while five (5) suggests that proposal appears to meet the City's key land use policies and guidelines. **This assessment is purely advisory and does not consider technical aspects of the proposal or in any way guarantee application approval.**

**It is important to note that the need for additional studies and plans may result during application review. If following the submission of your application, it is determined that material that is not identified in this checklist is required to achieve complete application status, in accordance with the Planning Act and Official Plan requirements, the Planning, Real Estate and Economic Development Department will notify you of outstanding material required within the required 30 day period. Mandatory pre-application consultation will not shorten the City's standard processing timelines, or guarantee that an application will be approved. It is intended to help educate and inform the applicant about submission requirements as well as municipal processes, policies, and key issues in advance of submitting a formal development application. This list is valid for one year following the meeting date. If the application is not submitted within this timeframe the applicant must again pre-consult with the Planning, Real Estate and Economic Development Department.**

### Description:

A Design Brief is the core submission document that illustrates how the development is designed to work with its existing and planned context, to improve its surroundings and also demonstrate how the proposal supports the overall goals of the Official Plan, relevant secondary plans, Council approved plans and design guidelines. The purpose of the Terms of Reference is to assist the applicant to organize and substantiate the design justification in support of the proposed development and to assist staff and the public in the review of the proposal.

### Authority to Request a Design Brief:

The *Planning Act* gives municipalities the authority to require that a Design Brief be prepared. Under Sections 22(4), (5) and Section 41(4) of the *Planning Act*, a Council has the authority to request such other information or material that the authority needs in order to evaluate and make a decision on an application. Section 5.2.6 of the Official Plan sets out the general requirement for a Design Brief.

### Preparation:

The Design Brief should be signed by an urban designer, licenced architect, landscape architect, or a full member of the Canadian Institute of Planners.

### When Required:

A Design Brief is required for a Site Plan Control planning application.

A Scoped Design Brief\* is required when the following planning applications are applied for and not accompanied by a Site Plan Control application:

- Official Plan Amendment
- Zoning By-law Amendment (exception: a change in use which does not result in an increase in height or massing)

The requirement and scope of a Design Brief will be determined at the formal pre-application consultation meeting. Should an application be required to go to the [Urban Design Review Panel \(UDRP\)](#), the Design Brief may be submitted as part of the submission materials to the panel.

### Contents for Design Brief Submissions:

A Design Brief will contain and/or address the points identified during the pre-consultation meeting. Failure to address the critical elements identified in the pre-consultation meeting may result in the application being considered incomplete.

\* A *Scoped Design Brief* is composed of:

- Section 1 should be combined into the *Planning Rationale* submission, and
- Section 2 items will be confirmed in the pre-application consultation meeting.

### SECTION 1

Application Submission:

Not Required

Required

State the: type of application, legal description, municipal address, purpose of the application and provide an overall vision statement and goals for the proposal.

Response to City Documents:

Not Required

Required

State the Official Plan land use designation for the subject property and demonstrate how the proposal conforms to the Official Plan as it relates to the design of the subject site. Reference specific policy numbers from the Official Plan to show consistency. Justify areas of non-compliance and explain why there is non-compliance.



State the applicable plans which apply to the subject proposal: community design plan, secondary plan, concept plan and design guideline. Reference the relevant design related polices within the applicable plans/guidelines and provide a comprehensive analysis as to how the proposed development incorporates the objectives or why it does not incorporate the objectives.

Context Plan:

Not Required

Required

Provide a contextual analysis that discusses/illustrates abutting properties, key destinations and linkages within a 100 meter radius (a larger radius may be requested for larger/more complex projects), such as transit stations, transportation networks for cars, cyclists, and pedestrians, focal points/nodes, gateways; parks/open spaces, topography, views towards the site, the urban pattern (streets, blocks), future and current proposals (if applicable), public art and heritage resources.



Photographs to illustrate existing site conditions and surrounding contexts. Include a map pinpointing (with numbers) where each photo is taken and correspond these numbers with the site photos. Arrows illustrating the direction the photo is taken is also useful.

### SECTION 2

#### Design Proposal:

The purpose of the Design Proposal is to show the building elevations, exterior details, transitions in form, treatment of the public realm and compatibility with adjacent buildings, using 3-D models, illustrations, diagrams, plans, and cross sections. Referencing Official Plan, Section 5.2.1, as determined at time of pre-application consultation meeting, submissions will need to address the following in the form of labelled graphics and written explanation:

#### **Massing and Scale**

Not Required

Required

#### *Images which show:*

#### Building massing – from:

- at least two sides set within its current context (showing the entire height and width of the building) **OR**
- all four sides set within its current context (showing the entire height and width of the building).

#### Views – of the entire block, from:

- at least two perspectives to show how the proposed building is set within its current context **OR**
- all four perspectives to show how the proposed building is set within its current context.

Building transition – to adjacent uses, with labelled explanation of the transition measures used.

Grading – if grades are an issue.

Alternative building massing – additional imagery and site layouts considered and provide justification for the ultimate proposal sought.

#### **Public Realm**

Not Required

Required

#### *Labelled graphics and a written explanation which show:*

Streetscape – cross sections which illustrate the street design and right of way (referencing the City’s design manuals).

Relationship to the public realm – illustrating how the first few storeys of the proposed development responds to and relates to the existing context (e.g. through a podium plan and first floor plan). This is to include detailed explanation on:

- Architectural responses
- Landscaping details
- Public art features (in accordance with Official Plan, Section 4.11)
- For developments in Design Priority Areas, detail the building and site features, (in accordance with Official Plan, Section 4.11) which will enhance the public realm. Provide explanation for features which are not provided.

### **Building Design**

Not Required

Required

Labelled graphics (e.g. building elevations and floor plans) and a written explanation which document the proposed exterior architectural details and design (in accordance with Official Plan, Section 5.2.1).



For high-rise development applications, detail the building design and massing and scale elements and how they relate to the proposed high-rise development (in accordance with Official Plan, Section 5.2.1).

### **Sustainability**

Not Required

Required

Any sustainable design features to be incorporated, such as green roofs or walls, sun traps, reflective or permeable surfaces.

### **Heritage**

Not Required

Required

How the building relates to the historic details, materials, site and setting of any existing historic resources on or adjacent to the subject property (if applicable).

### **Additional Contents:**

Some proponents may be requested to provide submission material which complements the Design Brief. These additional requirements could be incorporated into the Design Brief submission for ease of review. These will be identified at the time of application consultation meeting:

- Site Plan
- Landscape Plan
- Plan showing existing and proposed servicing
  - Shadow Analysis
  - Wind Analysis

### **Submission Requirements**

- Six hard copies and one digital copy

## **Formal Pre- Application Consultation Meeting Notes**

**File #: PC2022-0187**

**File Type: Site Plan Control**

**Location: Solarium & Brian Good**

**Wednesday, July 25, 2022 from 10:30 am – 11:30 am**

### **Attendees**

*City of Ottawa*

Melanie Gervais, File Lead

Ben Brummelhuis, Planning Student

Randolph Wang, Urban Designer

Eric Harrold, Infrastructure Project Manager

**Note:** Matthew Haley the Environmental Planner, Mike Giampa the Transportation Project Manager, Burl Walker the Parks Planner, and Mark Richardson the Forester for the Pre-application Consultation were not able to attend. Comments are added to this document and attached the email.

### **Notes & Comments**

*Planning Comments, Mélanie Gervais*

- Existing Official Plan – designated “General Urban Area” on Schedule B of the City of Ottawa’s Official Plan. The General Urban Area permits the development of a full range and choice of housing types to meet the needs of all ages, incomes, and life circumstances, in combination with conveniently located employment, retail, service, cultural, leisure, entertainment and institutional uses.
- In the New Official Plan, the subject site is identified as a “Suburban” Transect Policy Area. Under Section 5.4.1. (Policy 2), it states that the Suburban Transect is generally characterized by low-rise to mid-density development. Further, the Suburban (Southwest)Transect identifies the site as an “Neighbourhood”. Section 5.4.5 Provides direction to Neighbourhoods located within the Suburban Transect:
  - Generally, provides for up to 3 storeys height permission, and where appropriate 4 storey height permission to allow for higher density low-rise residential development.
  - Provides an emphasis on regulation the maximum built form envelope, based on the context, that frames the public right of way.



- The New Official Plan also includes City-Wide Policies that relate specifically to School Facilities (Section 4.1) – Policy 4.10.1 includes an emphasis on active travel, low vehicle speeds, covered and shaded bike parking, school lay-byes should be built with visually contrasting materials or colours and Policy 4.10.2 notes the City’s preference to locate schools and other neighbourhood uses close together such as daycares to provide convenient access to residents.
- The Riverside South CDP designates this property as School. The following guidelines have been created for schools:  
Section 2.3.6 which speaks to co-locating with parks, stormwater areas and other public facility and efforts should be made to share facilities.  
Section 6.5 speaks to the school built form where policies want fronting closing to street, walkways to connect entries to parking/bus/public sidewalk, bus loading as lay-byes in ROW, building reinforcing street corners, etc.
- Zoning Information: Split Zone Site - Minor Institutional Subzone A (I1A) and Residential Fourth Density Zone R4Z. Below is the zoning table for Subzone A with the required setbacks highlighted.

Table 170A - I1A Subzone provisions

I Zoning Mechanisms	Provisions		
	II Areas A and B on Schedule 1	III Abutting a residential zone in Area C on Schedule 1	IV Other cases
(a) Minimum Lot Width (m)	15		
(b) Minimum Lot Area (m <sup>2</sup> )	400		
(c) Minimum Front Yard Setback (m)	3	7.5	6
(d) Minimum Rear Yard Setback (m)	Abutting an R1, R2 or R3 Zone- 7.5 Other cases- 4.5	7.5	
(e) Minimum Interior Side Yard Setback (m)	7.5		3
(f) Minimum Corner Side Yard Setback (m)	4.5		
(g) Maximum Height (m)	15 (By-law 2017-303)		

- The City is happy to see the co-location of the daycare facility with the school, this is a positive step as identified in Policy 4.10.2 in the new Official Plan, which

encourages co-location of compatible land uses to encourage a walkable 15-minute neighbourhood.

- The zoning allows heights up to 15m (3-storeys) as of right. Please consider increasing the building height to three storeys to avoid future minor variance and site plan control applications in the future. Through the Building Better and Smarter Suburbs Initiative (Zoning By-law 2008-250: Omnibus Agreements Q3 2017 – Approved September 27, 2017), the City would like to see land efficiency on school sites.
- The new OP is encouraging school bus lay-byes and parent drop offs to be located on separate frontages, with visually contrasting materials or colours. It's great to see this being done, please consider making the lay-byes visual and stand out for children and families.
- In the new OP, Policy 4.10.1 includes encouragement of making it safe and easy to walk, bike or take transit to school through supportive site and neighbourhood design. Please consider adding a pedestrian pathway from the school to the adjacent park.
- The site is within Area C on Schedule 1A of the Zoning By-law (Areas for Minimum Parking Space Requirements). Please ensure the minimum parking space rates as set out in Section 101 are met for both school sites and daycare facilities. Please include these details on the site plan. There may be opportunities to have shared parking provisions between the school and park facilities, provided a shared parking agreement is in place.
- Include accessible stalls ([https://documents.ottawa.ca/sites/documents/files/documents/accessibility\\_design\\_standards\\_en.pdf](https://documents.ottawa.ca/sites/documents/files/documents/accessibility_design_standards_en.pdf)) and any EV charging locations of preferred green vehicle stalls.
- There is a requirement to provide a minimum amount of bicycle parking spaces on the site, see Section 111 of the Zoning By-law for applicable rates and citing requirements. Please ensure bike parking is covered, shaded and in a safe location and closest to the nearest possible building entrance. Please note that mulch within the bicycle parking area is ok if the bicycle racks are properly anchored as per Section 111 Subsection 10 "Where four or more bicycle parking spaces are provided in a common parking area, each bicycle parking space must contain a parking rack that is securely anchored to the ground and attached to a heavy base such as concrete." (Provide details on the Landscape Plan.)

*Infrastructure Project Manager Comments, Eric Harrold*

*List of Reports and Plans (Site Plan Control):*

- Site Servicing Plan

- Grading and Drainage Plan
- Erosion and Sediment Control Plan
- Storm Drainage and Ponding Plan
- Geotechnical Report
- Servicing and Stormwater Management Report / Brief

Please note the following information regarding the engineering design submissions for the above noted site:

1. The Servicing Study Guidelines for Development Applications are available at the following address:

<https://ottawa.ca/en/city-hall/planning-and-development/how-develop-property/development-application-review-process-2/guide-preparing-studies-and-plans>

2. Servicing and site works shall be in accordance with the following documents:

- Ottawa Sewer Design Guidelines, Second Edition, (October 2012), including Technical Bulletins, ISDTB-2014-01, PIEDTB-2016-01, ISTB 2018-01, ISTB-2018-04, and ISTB-2019-02
- Ottawa Design Guidelines – Water Distribution, First Edition, (July 2010), including Technical Bulletins ISD-2010-2, ISDTB-2014-02, ISTB-2018-02, and ISTB-2021-03
- Geotechnical Investigation and Reporting Guidelines for Development Applications in the City of Ottawa (Revised 2008)
- City of Ottawa Slope Stability Guidelines for Development Applications (Revised 2012)
- City of Ottawa Environmental Noise Control Guidelines (January, 2016)
- City of Ottawa Hydrogeological and Terrain Analysis Guidelines (March 2021)
- City of Ottawa Park and Pathway Development Manual (2012)
- City of Ottawa Accessibility Design Standards (2012)
- Ottawa Standard Tender Documents (latest version)
- Ontario Provincial Standards for Roads & Public Works (2013)

3. Record drawings and utility plans are also available for purchase from the City (Contact the City's Information Centre by email at [geoinformation@ottawa.ca](mailto:geoinformation@ottawa.ca) or by phone at (613) 580-2424 x 44455

4. The Stormwater Management Criteria for the subject site is to be based on the following:

- The servicing criteria and design for this site is outlined in the **River's Edge – Phase 1 Design Brief**. Please refer to this report for servicing details and stormwater quantity objectives. Provide the following link

(<https://cmap466/documents/TECHNICAL%20LIBRARY/REPORTS/5000/R-5398.pdf>) to [geoinformation@ottawa.ca](mailto:geoinformation@ottawa.ca) in order to access the report.

- Stormwater is to be restricted to the 2 year modelled flow using an assumed runoff coefficient of 0.7, a drainage area of 2.74 hectares and a calculated time of concentration (cannot be less than 10 minutes).
- All major flow must be contained on site; ensure no overland flow for all storms up to and including the 100-year event.
- Stormwater quality criteria may apply; please consult with the RVCA.
- There may be area specific subwatershed studies which may apply; please verify.

### 5. Deep Services:

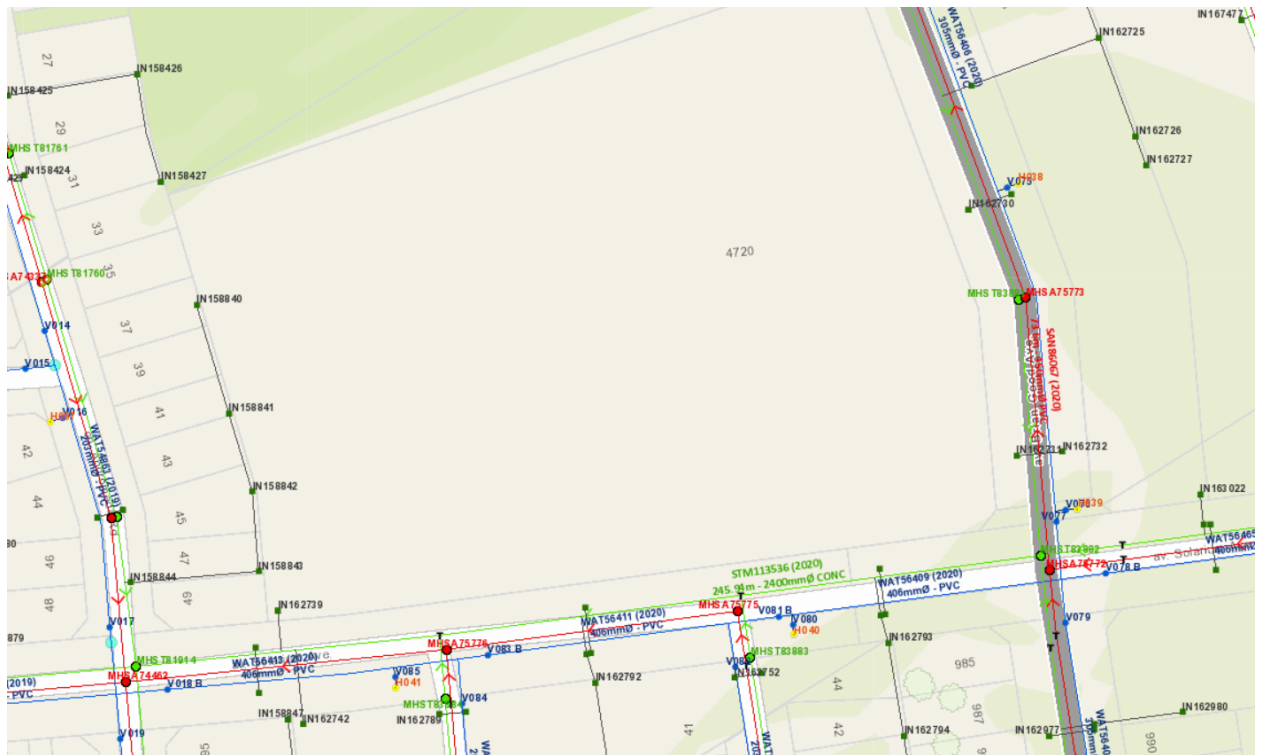

Hydrants



Hydrant Laterals



Water Pipes

— Public

--- Private

Valves

● Valve

■ TVS, A, D



i. *A plan view of the approximate services may be seen above. Services should ideally be grouped in a common trench to minimize the number of road cuts. The sizing of available future services is:*

a. **Connections:**

- i. 406 mm dia. Watermain (PVC) – Solarium
- ii. 450 mm dia. SAN (PVC) – Brian Goode \*
- iii. 2400 mm dia. STM (concrete) – Solarium

\* There is also a 200mm PVC sanitary sewer on Solarium which may be viable for connection. Please review the design sheets in the subdivision servicing report to confirm that there is adequate capacity to accommodate the proposed development, if this connection is to be used.

ii. *Provide existing servicing information and the recommended location for the proposed connections. Services should ideally be grouped in a common trench to minimize the number of road cuts.*

iii. *Provide information on the monitoring manhole requirements – should be located in an accessible location on private property near the property line (ie. Not in a parking area).*

iv. *Provide information on the type of connection permitted*

Sewer connections to be made above the springline of the sewermain as per:

- a. Std Dwg S11.1 for flexible main sewers – *connections made using approved tee or wye fittings.*
- b. Std Dwg S11 (For rigid main sewers) – *lateral must be less than 50% the diameter of the sewermain,*
- c. Std Dwg S11.2 (for rigid main sewers using bell end insert method) – *for larger diameter laterals where manufactured inserts are not available; lateral must be less than 50% the diameter of the sewermain,*
- d. Connections to manholes permitted when the connection is to rigid main sewers where the lateral exceeds 50% the diameter of the

sewermain. – Connect obvert to obvert with the outlet pipe unless pipes are a similar size.

e. *No submerged outlet connections.*

v. *Please provide estimated sanitary flows with the first submission, to allow the City to confirm whether there are any downstream capacity constraints.*

6. Civil consultant must request boundary conditions from the City's assigned Project Manager prior to first submission. Water Boundary condition requests must include the location of the service and the expected loads required by the proposed development. **Water boundary conditions should be based on the recently released 2020 Fire Underwriters Survey guidelines.** Please note that there is approximately a 3 week turnaround for boundary conditions results, so it is recommended that these be coordinated early on to avoid delays.

Please provide the following information:

- i. Location of service(s)
  - ii. Type of development and the amount of fire flow required (as per FUS, 2020).
  - iii. Average daily demand: \_\_\_ l/s.
  - iv. Maximum daily demand: \_\_\_ l/s.
  - v. Maximum hourly daily demand: \_\_\_ l/s.
  - vi. Hydrant location and spacing to meet City's Water Design guidelines.
  - vii. Water supply redundancy will be required for more than 50 m<sup>3</sup>/day water demand.
7. Phase 1 ESAs and Phase 2 ESAs must conform to clause 4.8.4 of the Official Plan that requires that development applications conform to Ontario Regulation 153/04.
8. All development applications should be considered for an Environmental Compliance Approval (ECA) by the Ministry of the Environment, Conservation, and Parks (MECP);
- a. The consultants determine if an approval for sewage works under Section 53 of OWRA is required and determines what type of application. The City's project manager may help confirm and coordinate with the MECP as required.
  - b. The project will be either transfer of review (standard), transfer of review (additional), direct submission, or exempt as per O. Reg. 525/98.
  - c. Pre-consultation is not required if applying for standard or additional works (Schedule A of the Agreement) under Transfer Review.

- d. Pre-consultation with local District office of MECP is recommended for direct submission.
- e. Consultant completes an MECP request form for a pre-consultation. Send request to [moeccottawasewage@ontario.ca](mailto:moeccottawasewage@ontario.ca)
- f. ECA applications are required to be submitted online through the MECP portal. A business account required to submit ECA application. For more information visit <https://www.ontario.ca/page/environmental-compliance-approval>

NOTE: Site Plan Approval, or Draft Approval, is required before an application is sent to the MECP.

9. General Engineering Submission requirements:

- a. As per section 53 of the Professional Engineers Act, O. Reg 941/40, R.S.O. 1990, all documents prepared by engineers must be signed and dated on the seal.
- b. All required plans are to be submitted on standard A1 size sheets (594mm x 841mm) sheets, utilizing a reasonable and appropriate metric scale as per City of Ottawa Servicing and Grading Plan Requirements: title blocks are to be placed on the right of the sheets and not along the bottom. Engineering plans may be combined, but the Site Plans must be provided separately. Plans shall include the survey monument used to confirm datum. Information shall be provided to enable a non-surveyor to locate the survey monument presented by the consultant.
- c. All required plans & reports are to be provided in \*.pdf format (at application submission and for any, and all, re-submissions)

Should you have any questions or require additional information, please contact me directly at (613) 580-2424, ext. 21447 or by email at [eric.harrold@ottawa.ca](mailto:eric.harrold@ottawa.ca).

*Urban Design Comments, Randolph Wang*

- A Design Brief is required. The Terms of Reference for the Design Brief is attached for convenience.
- Overall, the site plan layout is trending in the right direction. Here are a few detailed comments:
  - Provide continuous tree canopy along both Solarium & Brian Good.

- Maximize tree canopy coverage throughout the site where possible and reduce hard surfaces.
- Provide understory planting and foundation planting where appropriate.
- The amount of asphalt used on site is quite astonishing. Please consider:
  - Replacing asphalt with interlock pavers or concrete where possible.
  - Exploring colored asphalt options for visual interest and reducing urban heat island effects. Here are an interesting link regarding colored asphalt: [International Coloured Asphalt Foundation](#)
- The building looks playful graphically but is very flat spatially. Please consider:
  - Frames and shades around the windows that can add to the three-dimensional expression as well as to support sustainable design.
- Transitional materials between different colors and avoiding co-planarity.

*Transportation Project Manager Comments, Mike Giampa*

- A TIA is warranted. Steps 3 and 4 can be combined.
- The application will not be deemed complete until the submission of the draft step 2-4, including the functional draft RMA package (if applicable). Please note the RMA review process is experiencing significant delays. Although a full review of the TIA Strategy report (Step 4) is not required prior to an application, it is strongly recommended. Synchro files are required at Step 4.
- The corner sight triangle is to be: 5m x 5m
- A Road Noise Impact Study is required.
- The throat length requirements should follow the TAC guidelines.
- No ROW protection on Solarium and Brian Goode.
- Please indicate the municipal address on all reports and correspondence

*Environmental Planning Comments, Matthew Haley*

- Urban Heat Island Effect
- Please add features that reduce the urban heat island effect (see New OP 10.3.3) produced by the parking lot, asphalt apron and building footprint. For example, this impact can be reduced by adding large canopy trees, green roofs or vegetation walls, low heat absorbing materials/colours.
- Bird-safe Design
- The applicant team needs to consider the bird-safe design guidelines [https://documents.ottawa.ca/sites/documents/files/birdsafedesign\\_guidelines\\_en.pdf](https://documents.ottawa.ca/sites/documents/files/birdsafedesign_guidelines_en.pdf) and incorporate those elements into their design. Items to be include actions to make glass/glazing bird-safe, avoiding design traps (e.g., apparent flythroughs, entrapments, corner glass, etc.), consider structural hazards (e.g., glass railings, antennas, grate size, etc), landscaping that doesn't attract birds to



hazards, lighting design needs to consider bird-safe design. If there are a large number of windows (especially corner glass), please use bird-safe glazing as per the design guidelines.

*Forestry Comments, Mark Richardson*

- There aren't any trees on this site so a permit will not be needed and a TCR is not required.

LP tree planting requirements:

For additional information on the following please contact [tracy.smith@Ottawa.ca](mailto:tracy.smith@Ottawa.ca)

Minimum Setbacks

- Maintain 1.5m from sidewalk or MUP/cycle track or water service laterals.
- Maintain 2.5m from curb
- Coniferous species require a minimum 4.5m setback from curb, sidewalk or MUP/cycle track/pathway.
- Maintain 7.5m between large growing trees, and 4m between small growing trees. Park or open space planting should consider 10m spacing, except where otherwise approved in naturalization / afforestation areas. Adhere to Ottawa Hydro's planting guidelines (species and setbacks) when planting around overhead primary conductors.

Tree specifications

- Minimum stock size: 50mm tree caliper for deciduous, 200cm height for coniferous.
- Maximize the use of large deciduous species wherever possible to maximize future canopy coverage
- Tree planting on city property shall be in accordance with the City of Ottawa's Tree Planting Specification; and include watering and warranty as described in the specification (can be provided by Forestry Services).
- Plant native trees whenever possible
- No root barriers, dead-man anchor systems, or planters are permitted.
- No tree stakes unless necessary (and only 1 on the prevailing winds side of the tree)

Hard surface planting

- Curb style planter is highly recommended
- No grates are to be used and if guards are required, City of Ottawa standard (which can be provided) shall be used.
- Trees are to be planted at grade

Soil Volume

- Please document on the LP that adequate soil volumes can be met:

Tree Type/Size	Single Tree Soil Volume (m3)	Multiple Tree Soil Volume (m3/tree)
Ornamental	15	9
Columnar	15	9
Small	20	12
Medium	25	15
Large	30	18
Conifer	25	15

Please note that these soil volumes are not applicable in cases with Sensitive Marine Clay.

#### Sensitive Marine Clay

- Please follow the City's 2017 Tree Planting in Sensitive Marine Clay guidelines

#### Tree Canopy Cover

- The landscape plan shall show how the proposed tree planting will replace and increase canopy cover on the site over time, to support the City's 40% urban forest canopy cover target.
- At a site level, efforts shall be made to provide as much canopy cover as possible, through tree planting and tree retention, with an aim of 40% canopy cover at 40 years, as appropriate.
- Indicate on the plan the projected future canopy cover at 40 years for the site.

#### *Parks Planning Comments, Burl Walker*

- Parks and Facilities Planning is currently undertaking a legislated replacement of the Parkland Dedication By-law, with the new by-law to be considered by City Council on August 31, 2022. The by-law recommended for approval by Council includes one-year transition policies for in-stream development and building permit applications or those that will be submitted and meet the requirements for completeness by September 1, 2022.
- It is anticipated that the proposed site plan control application would be submitted after September 1 and would be subject to the provisions of the new Parkland

Dedication By-law. The proposed school use would be exempt from parkland dedication under subsection 11(2)(f) of the new Parkland Dedication By-law that was recommended for approval at the July 7, 2022, Planning Committee meeting.

- The school block is located adjacent to Atrium Park, which is a 2.4 ha neighbourhood park. The park is currently under construction with substantial completion targeted for fall 2022. Park amenities will include a full-size soccer field, full-size basketball court, double pickleball courts, outdoor fitness equipment, splash pad, playground, shade shelter and parking lot. I've attached an excerpt of the issued for construction drawings for the park for reference. Please note that the drawings were also provided to Laurel Leslie at the OCSB on June 16, 2022.
- We have no comments on the Site Plan – Option A drawing that was submitted with the application.



**Appendix F      Roof Drain and ICD Product Data Sheets**

## PRODUCT TECHNICAL SPECIFICATION

### General

Inlet control devices (ICD's) are designed to provide flow control at a specified rate for a given water head level and also provide odour and floatable control. All ICD's will be IPEX Tempest or approved equal.

All devices shall be removable from a universal mounting plate. An operator from street level using only a T-bar with a hook will be able to retrieve the device while leaving the universal mounting plate secured to the catch basin wall face. The removal of the TEMPEST devices listed above must not require any unbolting or special manipulation or any special tools.

High Flow (HF) Sump devices will consist of a removable threaded cap which can be accessible from street level with out entry into the catchbasin (CB). The removal of the threaded cap shall not require any special tools other than the operator's hand.

ICD's shall have no moving parts.

### Materials

ICD's are to be manufactured from Polyvinyl Chloride (PVC) or Polyurethane material, designed to be durable enough to withstand multiple freeze-thaw cycles and exposure to harsh elements.

The inner ring seal will be manufactured using a Buna or Nitrile material with hardness between Duro 50 and Duro 70.

The wall seal is to be comprised of a 3/8" thick Neoprene Closed Cell Sponge gasket which is attached to the back of the wall plate.

All hardware will be made from 304 stainless steel.

### Dimensioning

The Low Medium Flow (LMF), High Flow (HF) and the High Flow (HF) Sump shall allow for a minimum outlet pipe diameter of 200mm with a 600mm deep Catch Basin sump.

### Installation

Contractor shall be responsible for securing, supporting and connecting the ICD's to the existing influent pipe and catchbasin/manhole structure as specified and designed by the Engineer.

## PRODUCT INFORMATION: TEMPEST HF & MHF ICD

### Product Description

Our HF, HF Sump and MHF ICD's are designed to accommodate catch basins or manholes with sewer outlet pipes 6" in diameter or larger. Any storm sewer larger than 12" may require custom modification. However, IPEX can custom build a TEMPEST device to accommodate virtually any storm sewer size.

Available in 5 preset flow curves, these ICDs have the ability to provide constant flow rates: 9lps (143 gpm) and greater

### Product Function

**TEMPEST HF (High Flow):** designed to manage moderate to higher flows 15 L/s (240 gpm) or greater and prevent the propagation of odour and floatables. With this device, the cross-sectional area of the device is larger than the orifice diameter and has been designed to limit head losses. The HF ICD can also be ordered without flow control when only odour and floatable control is required.



**TEMPEST HF (High Flow) Sump:** The height of a sewer outlet pipe in a catch basin is not always conveniently located. At times it may be located very close to the catch basin floor, not providing enough sump for one of the other TEMPEST ICDs with universal back plate to be installed. In these applications, the HF Sump is offered. The HF Sump offers the same features and benefits as the HF ICD; however, is designed to raise the outlet in a square or round catch basin structure. When installed, the HF sump is fixed in place and not easily removed. Any required service to the device is performed through a clean-out located in the top of the device which can be often accessed from ground level.

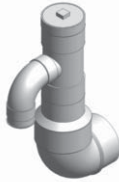

### TEMPEST MHF (Medium to High Flow):

The MHF plate or plug is designed to control flow rates 9 L/s (143 gpm) or greater. It is not designed to prevent the propagation of odour and floatables.



### Product Construction

The HF, HF Sump and MHF ICDs are built to be light weight at a maximum weight of 6.8 Kg (14.6 lbs).

### Product Applications

The HF and MHF ICD's are available to accommodate both square and round applications:



#### Square Application

Universal Mounting Plate

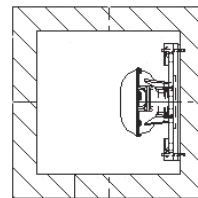

#### Round Application

Spigot CB Wall Plate



Universal Mounting Plate Hub Adapter



+

=

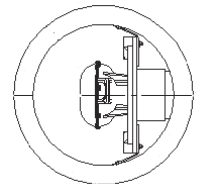
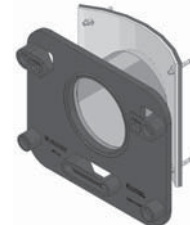

The HF Sump is available to accommodate low to no sump applications in both square and round catch basins:

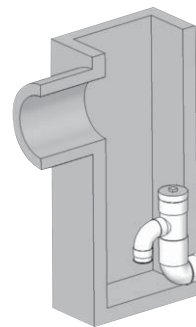

Square Catch Basin

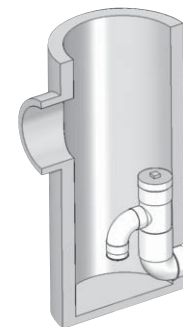

Round Catch Basin

**Chart 3: HF & MHF Preset Flow Curves**

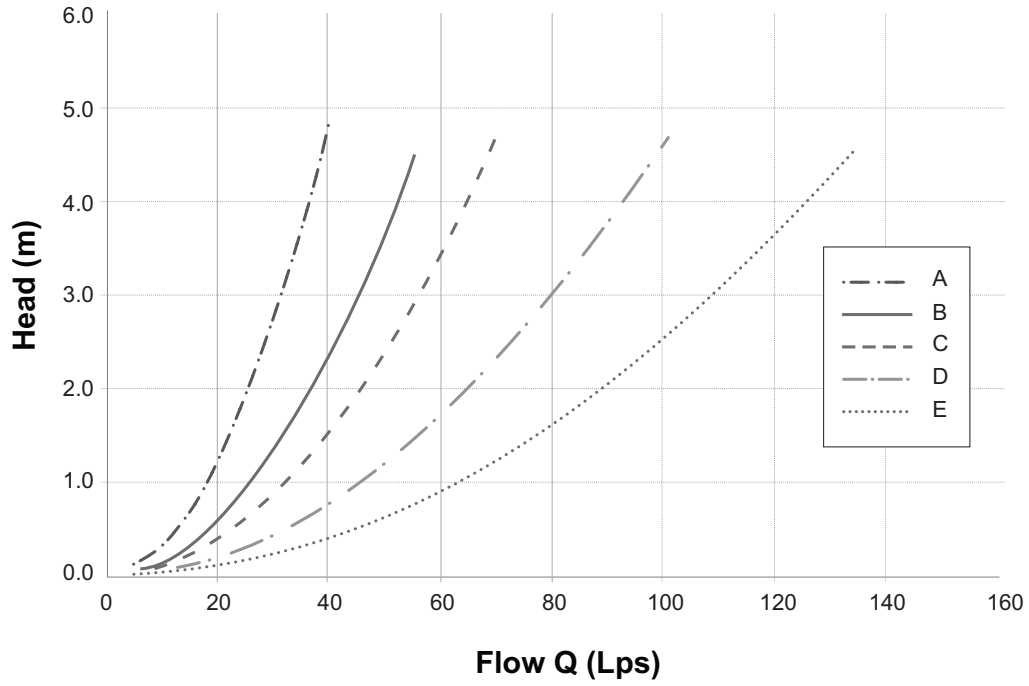

TEMPEST  
 HF & MHF ICD



# RD-100

Tag: \_\_\_\_\_

## Large Capacity Roof Drain

### Components:



**SPECIFICATION:** Watts Drainage Products RD-100 epoxy coated cast iron roof drain with deep sump, wide serrated flashing flange, flashing clamp device with integral gravel stop and self-locking polyethylene (standard) dome strainer.

Order Code: RD-10   -  -

Ex. RD-102P-K

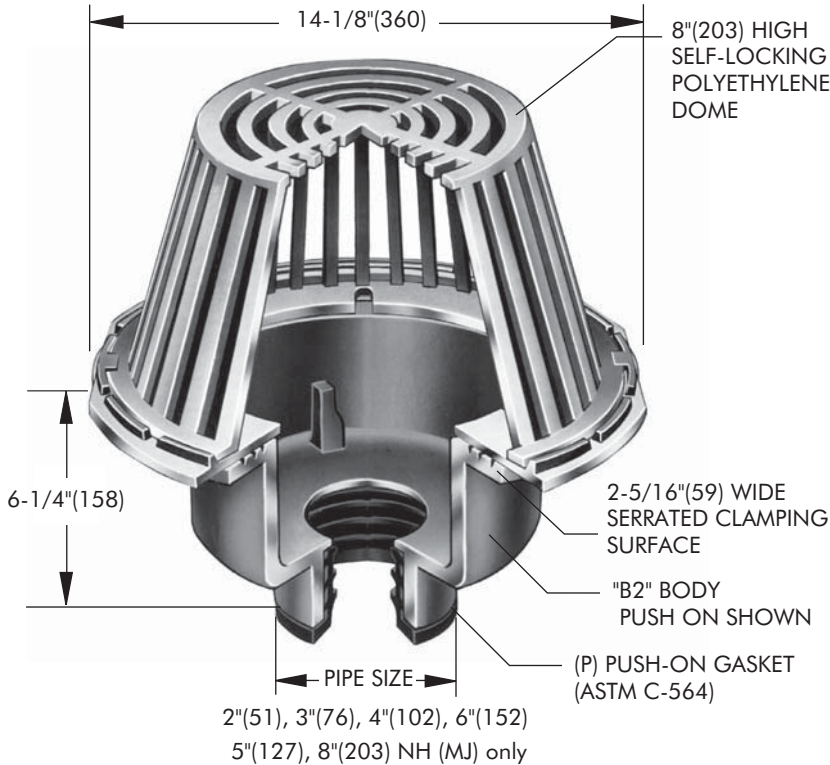

Free Area Sq. In.
137

**Deck opening 10" (254)  
with sump receiver 13-1/4" (337)**

Pipe Sizing (Select One)		
Suffix	Description	
2	2"(51) Pipe Size	<input type="checkbox"/>
3	3"(76) Pipe Size	<input type="checkbox"/>
4	4"(102) Pipe Size	<input type="checkbox"/>
5	5"(127) Pipe Size	<input type="checkbox"/>
6	6"(152) Pipe Size	<input type="checkbox"/>
8	8"(203) Pipe Size	<input type="checkbox"/>

Outlet Type (Select One)		
Suffix	Description	
NH	No Hub (MJ)	<input type="checkbox"/>
P	Push On	<input type="checkbox"/>
T	Threaded Outlet	<input type="checkbox"/>
X	Inside Caulk	<input type="checkbox"/>

Options (Select One or More)		
Suffix	Description	
-A	Accutrol weir (specify # 1-6 slots)	<input type="checkbox"/>
-B	Sump Receiver Flange	<input type="checkbox"/>
-BED	Sump Receiver, Adj Ext., Deck Clamp	<input type="checkbox"/>
-C	Secondary Membrane Clamp	<input type="checkbox"/>
-D	Underdeck Clamp	<input type="checkbox"/>
-E	Adjustable Extension	<input type="checkbox"/>
-GSS	Stainless Steel Ballast Guard	<input type="checkbox"/>
-H	Adj. to 6" IRMA Ballast Guard	<input type="checkbox"/>
-K	Ductile Iron Dome	<input type="checkbox"/>
-K80	Aluminum Dome	<input type="checkbox"/>
-L	Vandal Proof Dome	<input type="checkbox"/>
-R	2" High External Water Dam	<input type="checkbox"/>
-SO	Side Outlet**	<input type="checkbox"/>
-V	Fixed Extension (1-1/2",2",3",4")	<input type="checkbox"/>
-W	Adj. Water Level Regulator	<input type="checkbox"/>
-W-1	Waterproofing Flange	<input type="checkbox"/>
-Z	Extended Integral Wide Flange	<input type="checkbox"/>
-5	Sediment Bucket	<input type="checkbox"/>
-12	Galvanized Dome	<input type="checkbox"/>
-13	All Galvanized	<input type="checkbox"/>
-83	Mesh Covered Dome	<input type="checkbox"/>
-113M	Special Epoxy from 3M Range	<input type="checkbox"/>

Optional Body Material (NH Only)		
Suffix	Description	
-60	PVC Body w/Socket Outlet	<input type="checkbox"/>
-61	ABS Body w/Socket Outlet	<input type="checkbox"/>

\*\* Side Outlet (-SO) option only available in 2"(51), 3"(76), 4"(102) pipe sizes.  
Underdeck Clamp (-BED and -D options) are not available when -SO is selected.

Job Name \_\_\_\_\_ Contractor \_\_\_\_\_

Job Location \_\_\_\_\_ Contractor's P.O. No. \_\_\_\_\_

Engineer \_\_\_\_\_ Representative \_\_\_\_\_

WATTS Drainage reserves the right to modify or change product design or construction without prior notice and without incurring any obligation to make similar changes and modifications to products previously or subsequently sold. See your WATTS Drainage representative for any clarification. Dimensions are subject to manufacturing tolerances.



CANADA: 5435 North Service Road, Burlington, ON, L7L 5H7 TEL: 905-332-6718 TOLL-FREE: 1-888-208-8927 Website: www.wattsdrainage.ca





### ACCUTROL WEIR FLOW CONTROL

**SPECIFICATION:** Watts Drainage Products epoxy coated cast iron Accutrol Weir is designed with parabolic openings which limit the flow of rain water off a roof. Each weir slot controls flow to 5 gpm per inch of head to a maximum of 30 gpm at 6" head (for large sump), 25 gpm at 5" head (for small sump). The Accutrol Weir is secured to the flashing clamp of the roof drain. The Accutrol Weir is available with 1 to 4 slots for the large sump drain and up to 3 slots for the small sump drain.

**For Large Sump Roof Drains Specify the "-A" option and number of slots required. (ie. "RD-100-A2" for two slot weir)**

**For Small Sump Roof Drains Specify the "-A" option and number of slots required. (ie. "RD-200-A1" for one slot weir)**

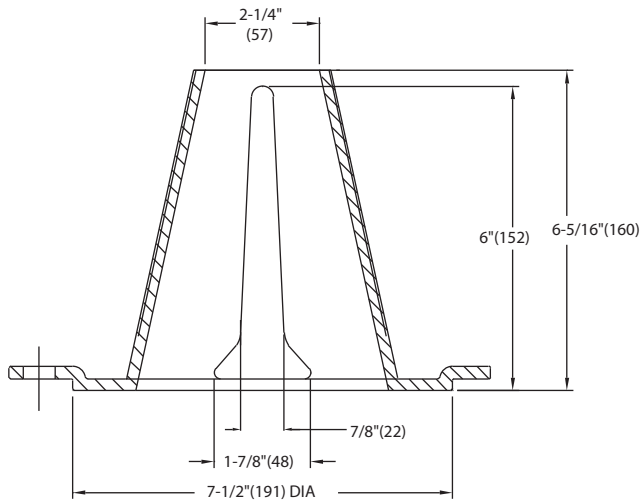

**LARGE SUMP ACCUTROL WEIR**

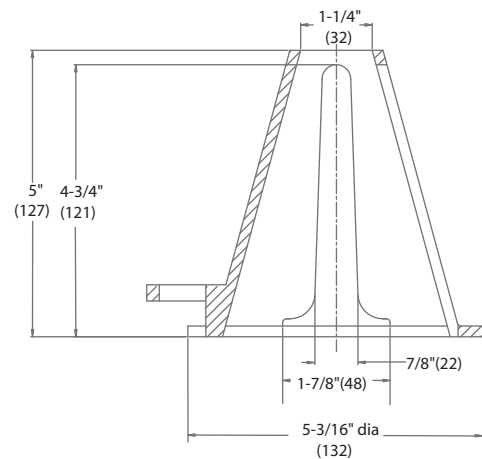

**SMALL SUMP ACCUTROL WEIR**

Job Name \_\_\_\_\_ Contractor \_\_\_\_\_

Job Location \_\_\_\_\_ Contractor's P.O. No. \_\_\_\_\_

Engineer \_\_\_\_\_ Representative \_\_\_\_\_

WATTS Drainage reserves the right to modify or change product design or construction without prior notice and without incurring any obligation to make similar changes and modifications to products previously or subsequently sold. See your WATTS Drainage representative for any clarification. Dimensions are subject to manufacturing tolerances.



**Appendix G - Boundary Conditions (pending)**



## **Appendix H - Subdivision Documents**







