

OTTAWA CATHOLIC SCHOOL BOARD

OCSB RIVERSIDE SOUTH ELEMENTARY SCHOOL NOISE IMPACT STUDY

SEPTEMBER 01, 2022



wsp



OCSB RIVERSIDE SOUTH ELEMENTARY SCHOOL

NOISE IMPACT STUDY

OTTAWA CATHOLIC SCHOOL BOARD

PROJECT NO.: 221-08213-00
DATE: SEPTEMBER 01, 2022

WSP
UNIT 2
126 DON HILLOCK DRIVE
AURORA, ON, CANADA L4G 0G9

T: +1 905 750-3080
F: +1 905 727-0463
WSP.COM

VERSION HISTORY

VERSION	DATE	TITLE	COMMENTS	PREPARED BY
1.0	September 01, 2022	Noise Impact Study	Issued for Submission	WSP

SIGNATURES

PREPARED BY

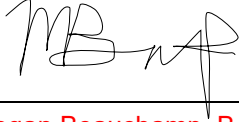

Megan Beauchamp, B.Eng., EIT
Acoustics, Noise and Vibration Specialist

REVIEWED BY



Carolyn Ropp, B.Sc.,
Intermediate Acoustics, Noise and Vibration
Specialist



Cris delos Santos, M.Eng., P.Eng.
Senior Engineer, Acoustics, Noise & Vibration

LIMITATIONS STATEMENT

WSP Canada Inc. (WSP) prepared this report solely for the use of the intended recipient, OTTAWA CATHOLIC SCHOOL BOARD, in accordance with the professional services agreement between the parties. In the event a contract has not been executed, the parties agree that the WSP General Terms for Consultant shall govern their business relationship which was provided to you prior to the preparation of this report.

The report is intended to be used in its entirety. No excerpts may be taken to be representative of the findings in the assessment.

The conclusions presented in this report are based on work performed by trained, professional and technical staff, in accordance with their reasonable interpretation of current and accepted engineering and scientific practices at the time the work was performed.

The content and opinions contained in the present report are based on the observations and/or information available to WSP at the time of preparation, using investigation techniques and engineering analysis methods consistent with those ordinarily exercised by WSP and other engineering/scientific practitioners working under similar conditions, and subject to the same time, financial and physical constraints applicable to this project.

WSP disclaims any obligation to update this report if, after the date of this report, any conditions appear to differ significantly from those presented in this report; however, WSP reserves the right to amend or supplement this report based on additional information, documentation or evidence.

WSP makes no other representations whatsoever concerning the legal significance of its findings.

The intended recipient is solely responsible for the disclosure of any information contained in this report. If a third party makes use of, relies on, or makes decisions in accordance with this report, said third party is solely responsible for such use, reliance or decisions. WSP does not accept responsibility for damages, if any, suffered by any third party as a result of decisions made or actions taken by said third party based on this report.

WSP has provided services to the intended recipient in accordance with the professional services agreement between the parties and in a manner consistent with that degree of care, skill and diligence normally provided by members of the same profession performing the same or comparable services in respect of projects of a similar nature in similar circumstances. It is understood and agreed by WSP and the recipient of this report that WSP provides no warranty, express or implied, of any kind. Without limiting the generality of the foregoing, it is agreed and understood by WSP and the recipient of this report that WSP makes no representation or warranty whatsoever as to the sufficiency of its scope of work for the purpose sought by the recipient of this report.

In preparing this report, WSP has relied in good faith on information provided by others, as noted in the report. WSP has reasonably assumed that the information provided is correct and WSP is not responsible for the accuracy or completeness of such information.

Benchmark and elevations used in this report are primarily to establish relative elevation differences between the specific testing and/or sampling locations and should not be used for other purposes, such as grading, excavating, construction, planning, development, etc.

The original of this digital file will be kept by WSP for a period of not less than 10 years. As the digital file transmitted to the intended recipient is no longer under the control of WSP, its integrity cannot be assured. As such, WSP does not guarantee any modifications made to this digital file subsequent to its transmission to the intended recipient.

This limitations statement is considered an integral part of this report.

EXECUTIVE SUMMARY

WSP Canada Inc. was retained by Ottawa Catholic School Board (OCSB) to complete an Environmental Noise Impact Study in support of an application for Site Plan Control Application (SPA) for the proposed OCSB Riverside South Elementary School development to be located at the corner of Brain Good Avenue and Solarium Avenue in Ottawa, Ontario (the Site). The Site consists of a main one-storey building and separate classroom portables, a play structure area, a sports field, and parking lot.

The purpose of the study is to assess the potential noise effects of the environment onto the Site and assess the potential noise impact of the proposed stationary noise sources at the Site on surrounding noise-sensitive areas. This report is based on the Site Plan, prepared by Pye & Richards – Temprano & Young Architects Inc., dated July 4, 2022 (“Issued for Client Review”).

The assessment was conducted in accordance with the City of Ottawa and the Ministry of Environment, Parks and Conservation (MECP) noise guidelines.

The significant sources of noise in the vicinity of the proposed development are transportation noise sources, mainly road traffic on Brain Good Avenue and Solarium Avenue, which are classified as urban collector roads. The significant stationary sources of noise at the Site are rooftop HVAC equipment.

Based on the predicted sound levels at the proposed development due to road traffic noise sources, exterior wall, door, and window construction meeting the Ontario Building Code (OBC) minimum requirements will be adequate to meet the indoor sound level limits to comply with the City of Ottawa and the MECP noise guidelines. Stationary sources at the Site are predicted to comply with the City of Ottawa and the MECP noise guidelines without additional noise control measures.

1	INTRODUCTION	1
1.1	The Site and Surrounding Area	1
1.2	The Proposed Development.....	1
2	NOISE IMPACT ASSESSMENT	2
2.1	Noise Sources.....	2
2.2	Noise Guidelines and Assessment Criteria	2
2.2.1	Road Sources Assessment Criteria	3
2.2.2	Stationary Sources Assessment Criteria	3
2.3	Road Sources	4
2.3.1	Road Traffic Data	4
2.3.2	Analysis Method	4
2.3.3	Results	5
2.3.4	Recommendations	5
2.3.5	Warning Clauses	6
2.4	Stationary Sources.....	6
2.4.1	Onsite Noise Sources	6
2.4.2	Receptors	7
2.4.3	Results	7
3	RECOMMENDATIONS AND CONCLUSIONS	9
3.1	Conclusions	9
3.2	Recommendations	9
	BIBLIOGRAPHY	10

TABLES

TABLE 2-1	ENCG & NPC-300 ROAD TRAFFIC INDOOR SOUND LEVEL CRITERIA FOR SCHOOLS.....	3
TABLE 2-2	BUILDING REQUIREMENTS FOR INDOOR SPACES.....	3
TABLE 2-3	MECP'S EXCLUSION LIMITS IN DBA	4
TABLE 2-4	SUMMARY OF ROAD TRAFFIC DATA USED IN THE TRANSPORTATION NOISE ANALYSIS	4
TABLE 2-5	SUMMARY OF PREDICTED FACADE SOUND LEVELS DUE TO ROAD TRAFFIC.....	5
TABLE 2-6	STATIONARY SOURCE SOUND DATA FOR PROPOSED SCHOOL.....	7
TABLE 2-7	PREDICTED SOUND LEVELS FROM ONSITE STATIONARY SOURCES ...	8
TABLE 3-1	SUMMARY OF NOISE CONTROL REQUIREMENTS.....	9

APPENDICES

FIGURES

A	DRAWINGS
B	TRAFFIC DATA
C	NEF/NEP CONTOUR MAP
D	STAMSON VALIDATION FILES
E	SUPPORTING INFORMATION
F	CADNA OUTPUT

1 INTRODUCTION

WSP Canada Inc. (WSP) was retained by Ottawa Catholic School Board (OCSB) to complete an Environmental Noise Impact Study for the proposed Riverside South Elementary School development to be located at the corner of Brain Good Avenue and Solarium Avenue in Ottawa, Ontario (the Site). This report was prepared in support of the Site Plan Approval application submission.

This assessment investigates both the potential for noise impacts of the environment onto the Site from the nearby transportation sources (i.e., Brain Good Avenue and Solarium Avenue) and proposed stationary sources at the Site onto surrounding noise-sensitive areas.

The purpose of the study is to assess the potential noise effects of the environment onto the Site and proposed stationary sources at the Site onto surrounding noise-sensitive areas. The findings and recommendations needed to comply with the applicable noise guidelines are included herein.

1.1 THE SITE AND SURROUNDING AREA

The Site is bounded by:

- To the east, Brain Good Avenue;
- To the south, Solarium Avenue;
- To the west, residential homes; and,
- To the north, an open space.

The Site is proposed to be surrounded by mostly residential lots. The location of the Site is shown in **Figure 1**. A zoning map showing the land use surrounding the proposed development obtained from the City of Ottawa is provided in **Figure 2**. The Site is zoned “IIE H(15)” Minor Institutional and the immediate surrounding area of the proposed development includes residential, institutional, and open space land uses.

1.2 THE PROPOSED DEVELOPMENT

This report was based on the Site Plan, prepared by Pye & Richards – Temprano & Young Architects Inc., dated July 4, 2022, and included as **Appendix A**. The Site consists of a main one-storey building, north of the main building there are three (3) portable 6-pack classrooms, to the northwest a play structure area, a sports field, and a parking lot directly west.

2 NOISE IMPACT ASSESSMENT

2.1 NOISE SOURCES

The City's *Environmental Noise Control Guidelines* (ENCG) stipulates that a noise study shall be prepared when a new development is proposed within distances as follows:

- 100 metres from the right-of-way of an existing or proposed road; arterial, major collector, light rail transit, bus rapid transit or transit priority corridor;
 - 250 metres from the right-of-way of an existing or proposed highway;
 - 300 metres from the right-of-way of a proposed or existing rail corridor or secondary main railway line;
 - 500 metres from the right-of-way of a freeway or 400-series provincial highway or principal main railway line; or
 - Defined area from the Noise Exposure Forecast (NEF) noise contour of airport / aircraft noise
-

SURFACE TRANSPORTATION NOISE SOURCES

The significant sources of noise in the vicinity of the proposed development are transportation noise sources. The road types were identified as collectors using the City's "Official Plan – Schedule E Urban Road Network" as provided in **Appendix B**. The road within 100 metres of the site are Solarium Avenue and Brain Good Avenue. Other roads, light rail transit, bus rapid transit, and transit priority corridor, are over 100 metres away from the Site and are not expected to have a significant impact.

Proposed and existing highways are further than 250 m away from the proposed school. Proposed or existing rail corridor or main railway lines are further than 300 m. Freeway and 400-series or principal railway line are further than 500 m. Therefore, these transportation noise sources are not included or significant to this assessment.

STATIONARY NOISE SOURCES

There are stationary noise sources originating from the proposed school building development which is surrounded by existing and future residential buildings. Therefore, stationary noise has been included in the study to assess the potential noise impacts of the proposed development on the surrounding noise sensitive land uses.

AIRCRAFT SOURCES

The proposed development is located outside the City of Ottawa's International Airport's (Macdonald-Cartier International Airport) Vicinity Development Zone and outside the Airport Operating Influencing Zone (AOIZ). Therefore, aircraft noise has not been considered in the assessment. **Figure 3** shows the Site location in relation to the airport's NEF/NEP contour map. The NEF/NEP contour map is included in **Appendix C**.

2.2 NOISE GUIDELINES AND ASSESSMENT CRITERIA

Noise is recognized as a pollutant in the Environmental Protection Act, as uncontrolled noise can affect human activities. Ontario provincial noise control guidelines require that noise concerns are addressed in the planning of any new development.

In land use planning, although elimination or control of the source of pollution is usually a primary objective, there are general limits as to what is practical and technically possible. The City's ENCG follows the MECP's Publication NPC-300, *Environmental Noise Guideline Stationary and Transportation Sources – Approval and Planning for*

acceptable levels of road and air traffic noise impacting noise-sensitive institutional developments and stationary noise on surrounding noise-sensitive residential areas. These limits are discussed in Section “Part C – Land Use Planning” of NPC-300 as well as Section 2 and 4 of the ENCG.

2.2.1 ROAD SOURCES ASSESSMENT CRITERIA

Table 2-1 summarizes sound level limits for road traffic applicable for the proposed institutional development.

Table 2-1 ENCG & NPC-300 Road Traffic Indoor Sound Level Criteria for Schools

AREA	TIME PERIOD	LEQ (dBA) ^[1] -ROAD	REFERENCE
Indoor Living/Dining Areas of Schools, Daycares	Daytime (0700 – 2300h)	45	NPC-300 Table C-2 ENCG Table 2.2b

Notes: [1] Daytime: $L_{EQ\ 16HR}$; Nighttime: $L_{EQ\ 8-HR}$.

The NPC-300 and ENCG provide sound level limits in terms of energy equivalent (average) sound levels [L_{EQ}] in units of A-weighted decibels (dBA) at a specific noise-sensitive location. Outdoor areas are not considered noise-sensitive for institutional developments. Therefore, only indoor locations are identified and only during the daytime period.

The building envelope, such as walls, windows and doors where applicable, should be designed so that the indoor sound levels comply with the sound level limits summarized in **Table 2-1** above.

BUILDING COMPONENT REQUIREMENTS

To comply with the indoor sound level criteria listed in **Table 2-1**, the ENCG and NPC-300 provides guidelines based on predicted sound level at the façade/plane of window. If the predicted sound level at the plane of window exceeds, additional considerations such as the type of windows, exterior walls, and doors that can provide noise attenuation must be selected. In addition, warning clauses to inform the future occupants are also required.

Table 2-2 summarizes requirements for type of building façade construction for institutional purpose buildings.

Table 2-2 Building Requirements for Indoor Spaces

AREA	TIME PERIOD	LEQ (DBA) ^[2]	BUILDING COMPONENT REQUIREMENTS
Plane of Window ^[1]	Daytime (0700 – 2300h)	≤ 55	Building components compliant with Ontario Building Code (OBC)
		> 55 and ≤ 65	Building components compliant with OBC
		> 65	Building components designed/selected to meet Indoor Requirements

Notes: [1] Plane of Window of an institutional purpose building leading to a noise sensitive room, such as teacher’s lounge, classrooms, etc.
[2] Daytime: $L_{EQ\ 16HR}$.

2.2.2 STATIONARY SOURCES ASSESSMENT CRITERIA

For stationary sources, the MECP NPC-300 and ENCG Section 3 provides criteria based on one-hour equivalent sound level. In order to comply with the noise impact from stationary sources, the predicted sound level must comply with the noise guidelines stipulated in NPC-300 and ENCG. Two locations are typically considered: an outdoor location and the plane of window.

Both guidelines provide sound level limits for noise-sensitive receptors based on the acoustical environment of the area. NPC-300 categorizes the acoustical environment into four classes: Class 1 (urban), Class 2 (semi-urban), Class 3 (rural), or Class 4 (special cases). Based on a review of the area using aerial imagery, the general area is currently under construction and thus, can be considered as Class 1 once fully developed. Given that the school only operates during the daytime, **Table 2-3** summarizes the MECP’s daytime sound level limit for a Class 1 Area and was used as the applicable sound level limit for the development.

Table 2-3 MECP’s Exclusion Limits in dBA

CLASS 1		
PERIOD	PLANE OF WINDOW ¹	OUTDOOR POR ²
Daytime (07:00 – 19:00)	50	50

Notes:

- 1 Plane of window means a point in space corresponding with the location of the centre of a window of a noise sensitive space
- 2 PoR means point of reception; representing a point in a receptor location.

2.3 ROAD SOURCES

2.3.1 ROAD TRAFFIC DATA

Road traffic data were obtained from the ENCG **Appendix B** for Brian Good Avenue and Solarium Avenue. The data obtained from the ENCG provides future traffic volume, day/night split, commercial vehicle percentages, and posted speed limits for various roadways based on roadway class and number of lanes. The ENCG data represents the future traffic volume and corresponding to a “mature state of development”, in the City’s Official Plan.

The traffic and road parameters used for sound level predictions are shown in **Table 2-4**. The surrounding topography is generally flat and assessed as such.

Table 2-4 Summary of Road Traffic Data Used in the Transportation Noise Analysis

ROAD	ROAD CLASSIFICATION	TRAFFIC VOLUMES (AADT)	DAY/NIGHT SPLIT (%)	MEDIUM TRUCKS (%)	HEAVY TRUCKS (%)	POSTED SPEED LIMIT (KPH)
Brian Good Avenue	2-Lane Urban Collector	8,000	92/8	7%	5%	40
Solarium Avenue	2-Lane Urban Collector	8,000	92/8	7%	5%	40

2.3.2 ANALYSIS METHOD

The MECP updated their guidance requiring the use of up-to-date noise prediction methods and software for determining the impacts of noise from roads and railways (Publication NPC-306 “Methods to Determine Sound Levels Due to Road and Rail Traffic” December 2021). The Publication NPC-306 replaces Publication NPC-206 “Sound Levels Due to Road Traffic”, dated October 1995, which referenced the use of ORNAMENT calculation procedures. Previous noise prediction methods using STAMSON, and MECP prediction software implementation of ORNAMENT, were based on a 1995 DOS program which is a modification of the U.S. Federal Highway Administration (FHWA) FHWA-RD-77-108 algorithm to simplify calculations with inherent limitations. Based on the MECP’s draft guidance, the new methods will lead to more accurate noise predictions, effective control measures and based on current science.

Although Publication NPC-306 is in circulation for comments as draft, further clarifications from the MECP to Noise Practitioners and Stakeholders suggests that the methods and software will not change. This assessment therefore uses the updated guidance set out in NPC-306 to account for complex features of the development and provide more accurate noise predictions. This is also in line with recent trends in industry best practices.

Road traffic sound levels at the proposed development were predicted using Cadna/A, a commercially available noise propagation modelling software. The following parameters were taken into consideration in the model:

- Road and rail alignments and gradients;
- Traffic volumes and design speeds;
- Commercial vehicle percentages for roads;
- Shielding provided by intervening buildings, barriers and/or topographical features; and
- Special details such as barrier and receptor locations, elevations, and heights.

The software’s Building Evaluation feature was used to predict the sound levels on every façade of the proposed school and portables. The software generates an array of receivers along each building facade producing a comprehensive analysis of where the highest sound levels from road noise will be located on the building.

Solarium Avenue and Brain Good Avenue were modelled as road source using the U.S. FHWA Traffic Noise Model (TNM) noise emission and calculation method implemented by Cadna/A. The TNM predictions were validated at the closest east façade of the one-storey building facing Brian Good Avenue and closest south façade facing solarium Avenue and are equivalent to those made using the MECP prediction software STAMSON, which is an implementation of the ORNAMENT calculation methods.

The STAMSON validation files are included in **Appendix D**.

The analysis method in the NRC document, BPN56 “Controlling Sound Transmissions into Buildings”, dated September 1985, were used to estimate the acoustical requirements for the building components.

2.3.3 RESULTS

Based on the road traffic data, sound levels were predicted at the proposed school. The Site’s location with respect to these roads is shown in **Figure 4**. The predicted sound levels were used to investigate building construction requirements. The highest sound levels on the façades of proposed development is summarized in **Table 2-5**.

Table 2-5 Summary of Predicted Facade Sound Levels due to Road Traffic

STRUCTURE	LOCATION DESCRIPTION	APPROXIMATE HEIGHT (M)	DAYTIME HIGHEST SOUND LEVEL LEQ (dBA)
Main School Building	Southeast corner, on east façade	2	63
Portables	Northeast corner, on east façade	2	61

2.3.4 RECOMMENDATIONS

As shown in **Table 2-5**, the sound levels at the plane of window are below 65 dBA during the daytime hours. Thus, wall, door and window glazing assemblies meeting the minimum non-acoustical requirements of the Ontario Building Code (OBC) will be sufficient to meet the applicable indoor sound level limits.

2.3.5 WARNING CLAUSES

As per ENCG and NPC-300, inclusion of appropriate warning clauses for ventilation is a requirement for residential dwellings; however, though a school is not considered a dwelling, as per previous comments received from the City for other noise impact studies previously completed for proposed schools within the City, a warning clause Type C for road noise was requested and provided below. The suggested warning clause wording is as follows; it can be modified or amended by the City's planning department, as appropriate:

Type C

"The school has been fitted with a forced air heating system and ducting, etc. and was sized to accommodate central air conditioning. Installation of central air conditioning by the occupant will allow windows and exterior doors to remain closed, thereby ensuring that the indoor sound levels are within the City's and the Ministry of the Environment's noise criteria." (Note: The location and installation of the outdoor air conditioning device should be done so as to comply with noise criteria of MECP Publication NPC-216, Residential Air Conditioning Devices and thus minimize the noise impacts both on and in the immediate vicinity of the subject property.)"

2.4 STATIONARY SOURCES

Stationary source is defined in MECP publication NPC-300 as source of sound or combination of sources of sound that are included and normally operated within the property lines of a facility. The ENCG states new stationary sources of noise (noise generating) are defined by proximity to existing or approved noise-sensitive developments.

As detailed mechanical design is not available at the time of this report, the noise sources associated with the proposed development were based on a similar sized school. The significant stationary sources of noise are the rooftop HVAC units and a condenser. Insignificant sources or sources with negligible sound level contribution off-site include hot water heaters, small fans, and indoor equipment. No emergency generator is planned at the Site. Bus drop-off location is to be located along Brian Good Avenue and located outside the school's property boundary (off-site noise source). Therefore, noise associated with bus drop-off activities is not included in the assessment.

2.4.1 ONSITE NOISE SOURCES

A total of six (6) rooftop HVAC units (RTUs) and two (2) condensers are planned on the main school building as shown in **Figure 5**. All six RTUs and both condensers were conservatively assumed to operate simultaneously for 60 minutes in a predictable worst-case hour during the day. The school operates only during the daytime between 0700h to 1900h and assessed as such.

Sound power levels for the RTUs were provided by the manufacturer (AAON) for both the exposed condenser section and exhaust fan outlet. The sound power levels for the VRF Condensers were taken from Daikin and Carrier model. The sound level data used in the assessment is summarized in **Table 2-6** and manufacturer's cutsheets are provided in **Appendix E**.

The source locations and receptors placed on the proposed development are provided in **Figure 5**.

In order to estimate the sound levels from stationary sources to the surrounding residential areas, a predictive analysis was completed using a commercially available software package CADNA/A, a computer implementation of the ISO Standard 9613-2 "Acoustics – Attenuation of Sound During Propagation Outdoors", which takes into account the following:

- Source sound power levels;
- Distance attenuation;
- Source-receptor geometry;
- Ground and air (atmospheric) attenuation; and,

— Temperature and humidity effects on noise propagation.

Key parameters used in the model and sample calculations are located in **Appendix F**.

Table 2-6 Stationary Source Sound Data for Proposed School

SOURCE ID ¹	BUILDING	DESCRIPTION	OVERALL SOUND POWER LEVEL (dBA)	OPERATION (Minutes)
				DAY
SS_RTU1c	Proposed 1-Storey Main School Building	HVAC 11T Unit Condenser	84	60
SS_RTU1e		HVAC 11T Unit Exhaust Air	85	60
SS_RTU2c		HVAC 6T Unit Condenser	81	60
SS_RTU2e		HVAC 6T Unit Exhaust Air	82	60
SS_RTU3c		HVAC 11T Unit Condenser	84	60
SS_RTU3e		HVAC 11T Unit Exhaust Air	87	60
SS_RTU4c		HVAC 11T Unit Condenser	84	60
SS_RTU4e		HVAC 11T Unit Exhaust Air	85	60
SS_RTU5c		HVAC 11T Unit Condenser	84	60
SS_RTU5e		HVAC 11T Unit Exhaust Air	85	60
SS_RTU6c		HVAC 11T Unit Condenser	84	60
SS_RTU6e		HVAC 11T Unit Exhaust Air	92	60
SS_CU1Ac		Air Cooled VRF 10T Condenser	85	60
SS_CU1Bc		Air Cooled VRF 10T Condenser	85	60

Notes:

[1] Refer **Figure 5** for source locations; locations are referred using these IDs.

2.4.2 RECEPTORS

Residential lots surround the site on east, south, and west sides. Adjacent to the site on the north is open space. Locations of the future residential buildings used in this analysis were based on the Site Plan. To the south the development plans were not available and therefore, lots and dwellings were assumed to have similar setback distance as the adjacent residential lots.

These buildings were analysed as receptors R01 to R09 at the second-floor plane of window (i.e. 4.5 m above ground) and are described in **Table 2-6**. Outdoor points of reception (receptors R01_O to R02_O) were assessed at standing height (i.e. 1.5 m above ground) representing the backyards. **Figure 5** shows the receptors in relation to onsite stationary noise sources.

2.4.3 RESULTS

IMPACTS FROM THE PROPOSED DEVELOPMENT ON THE SURROUNDING ENVIRONMENT

The overall sound levels at receptors of existing and potential surrounding residential homes, generated using assumed predictable worst-case operations of the school, are summarized in **Table 2-7**.

Table 2-7 Predicted Sound Levels from Onsite Stationary Sources

POR ID	POR DESCRIPTION	RECEPTOR HEIGHT (M)	PREDICTED SOUND LEVEL (dBA)	DAYTIME SOUND LEVEL LIMIT (dBA)	COMPLIANCE WITH LIMIT?
R01	2-storey Existing Residential Home to the West (Window)	4.5	40	50	Yes
R02	2-storey Existing Residential Home to the West (Window)	4.5	39	50	Yes
R01_O	2-storey Existing Residential Home to the West (Outdoor)	1.5	40	50	Yes
R02_O	2-storey Existing Residential Home to the West (Outdoor)	1.5	40	50	Yes
R03	2-storey Existing Residential Home to the West (Window)	4.5	44	50	Yes
R04	2-storey Existing Residential Home to the West (Window)	4.5	47	50	Yes
R05	2-storey Potential Residential Home to the South (Window)	4.5	47	50	Yes
R06	2-storey Potential Residential Home to the South (Window)	4.5	47	50	Yes
R07	2-storey Potential Residential Home to the South (Window)	4.5	47	50	Yes
R08	2-storey Potential Residential Home to the South (Window)	4.5	47	50	Yes
R09	2-storey Potential Residential Home to the South (Window)	4.5	44	50	Yes

As shown in **Table 2-7**, the predicted stationary source sound level of the proposed RTUs and condensers meet sound level limit at all receptors.

3 RECOMMENDATIONS AND CONCLUSIONS

3.1 CONCLUSIONS

This report has been prepared to support the Site Plan Approval application. The assessment evaluated the potential for noise impact of transportation sources on the Site, and stationary sources associated with the Site on nearby residential uses and stationary sources associated with the nearby public school on the proposed development.

The predicted sound levels were assessed as per the MECP Publication NPC-300 and ENCG requirements. The assessment demonstrates that the Site will comply with the applicable noise guidelines without additional noise control measures.

3.2 RECOMMENDATIONS

Table 3-1 summarizes the building recommendations for the school’s proposed development.

Table 3-1 Summary of Building Requirements

BUILDING	BUILDING COMPONENTS (WALLS) STC	BUILDING COMPONENTS (WINDOWS & DOORS) STC	WARNING CLAUSE	NOISE CONTROL MEASURES
1-Storey Main School Building	OBC ¹	OBC ¹	Type C	NA
Portables	OBC ¹	OBC ¹	Type C	NPC-216 ²

Notes:

¹ OBC – Meet or exceed the minimum non-acoustical requirement of Ontario Building Code (OBC).

² Where possible, select equipment to comply with noise criteria of MECP Publication NPC-216, Residential Air Conditioning Devices.

Warning clause Type C (as requested by the City based on previous projects).

"This school has been fitted with a forced air heating system and ducting, etc. and was sized to accommodate central air conditioning. Installation of central air conditioning by the occupant will allow windows and exterior doors to remain closed, thereby ensuring that the indoor sound levels are within the City’s and the Ministry of the Environment’s noise criteria” (Note: The location and installation of the outdoor air conditioning device should be done so as to comply with noise criteria of MECP Publication NPC-216, Residential Air Conditioning Devices and thus minimize the noise impacts both on and in the immediate vicinity of the subject property.)"

BIBLIOGRAPHY

- National Research Council of Canada (1995, September). Building Practice Note (BPN) No. 56: Controlling Sound Transmission into Buildings, Canada
- Ontario Ministry of the Environment and Climate Change (2013). Environmental Noise Guideline – Stationary and Transportation Sources – Approval and Planning – Publication NPC-300. Ontario, Canada
- Ontario Ministry of the Environment and Climate Change (1996), STAMSON v5.04: Road, Rail and Rapid Transit Noise Prediction Model, Ontario, Canada
- Ontario Ministry of the Environment (1989). Ontario Road Noise Analysis Method for Environment and Transportation (ORNAMENT), Ontario, Canada
- Ontario Ministry of the Environment and Energy (October 1995). Sound Level Due To Road Traffic Planning – Publication NPC-300. Ontario, Canada
- City of Ottawa (2016; January). Environmental Noise Control Guidelines (ENCG), Ontario, Canada

FIGURES



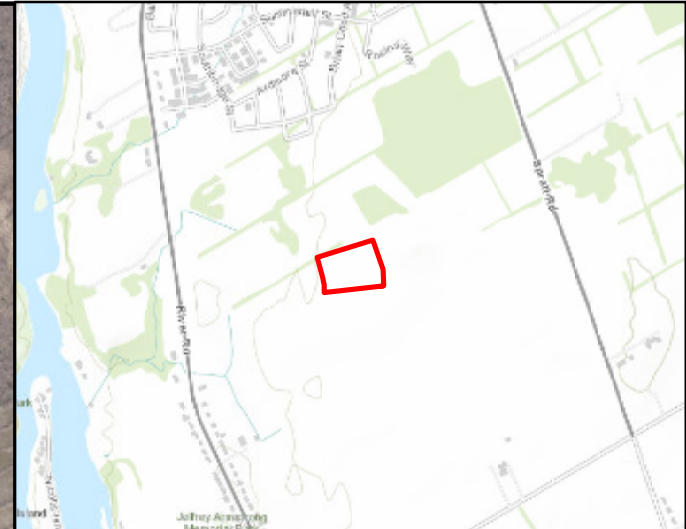

LEGEND:

- SITE BOUNDARY
- 1000 m STUDY AREA

TITLE:
THE SITE AND SURROUNDING AREA

PROJECT:
NOISE IMPACT STUDY
RIVERSIDE SOUTH ELEMENTARY SCHOOL
OTTAWA, ONTARIO

CLIENT:
OCSB

	PROJECT NO.:	REVIEWED BY:
	221-08213-00	CR
DATE:	FIGURE:	
AUGUST 2022	1	

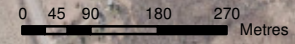

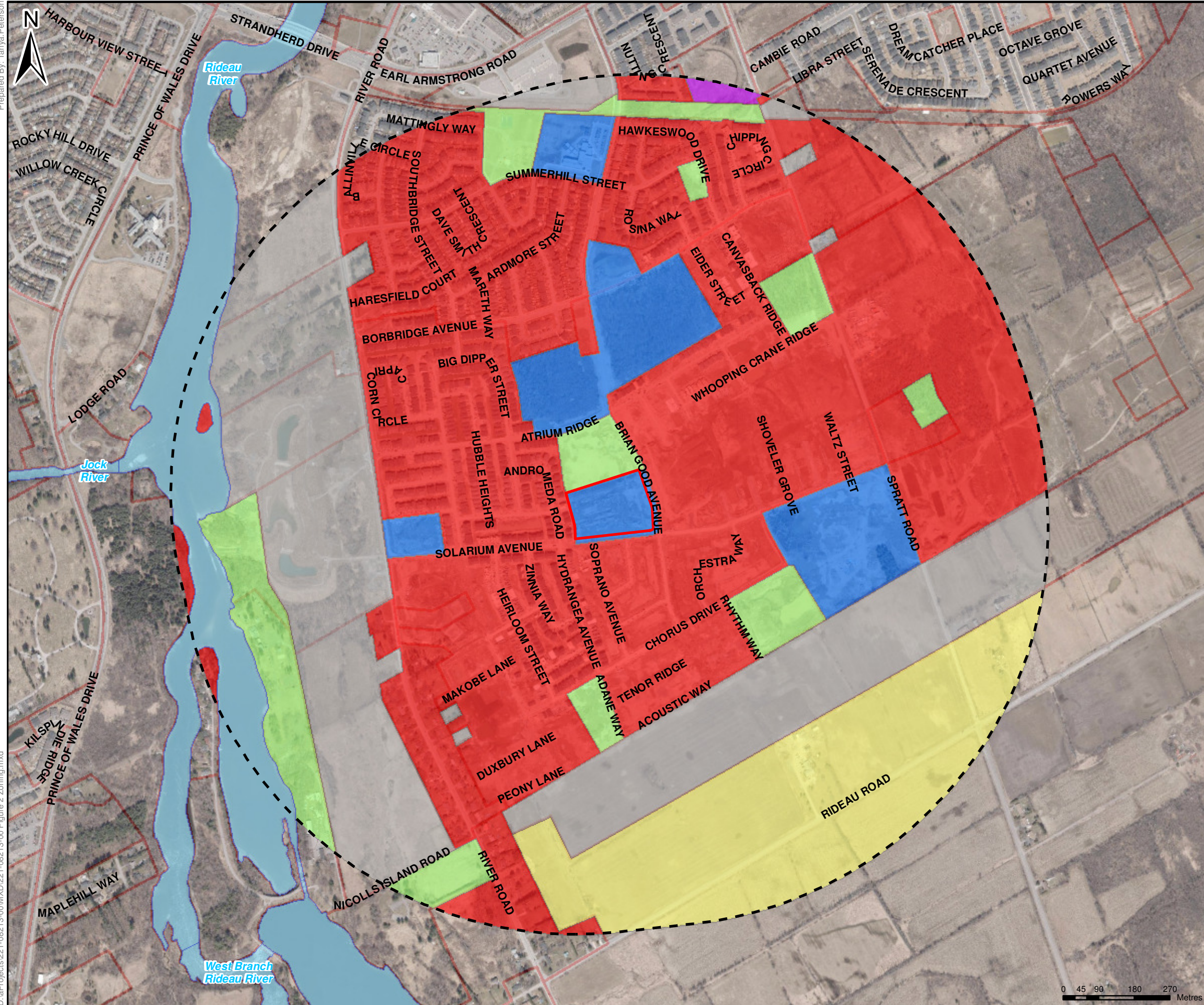

LEGEND:

	SITE BOUNDARY
	1000 m STUDY AREA
	WATERBODY
	AGRICULTURAL
	DEVELOPMENT RESERVE
	GENERAL MIXED USE ZONE
	INSTITUTIONAL
	OPEN SPACE
	RESIDENTIAL

TITLE: ZONING MAP

PROJECT: NOISE IMPACT STUDY
RIVERSIDE SOUTH ELEMENTARY SCHOOL
OTTAWA, ONTARIO

CLIENT: OCSB

 	PROJECT NO.: 221-08213-00	REVIEWED BY: CR
	DATE: AUGUST 2022	FIGURE: 2

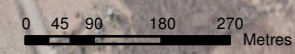

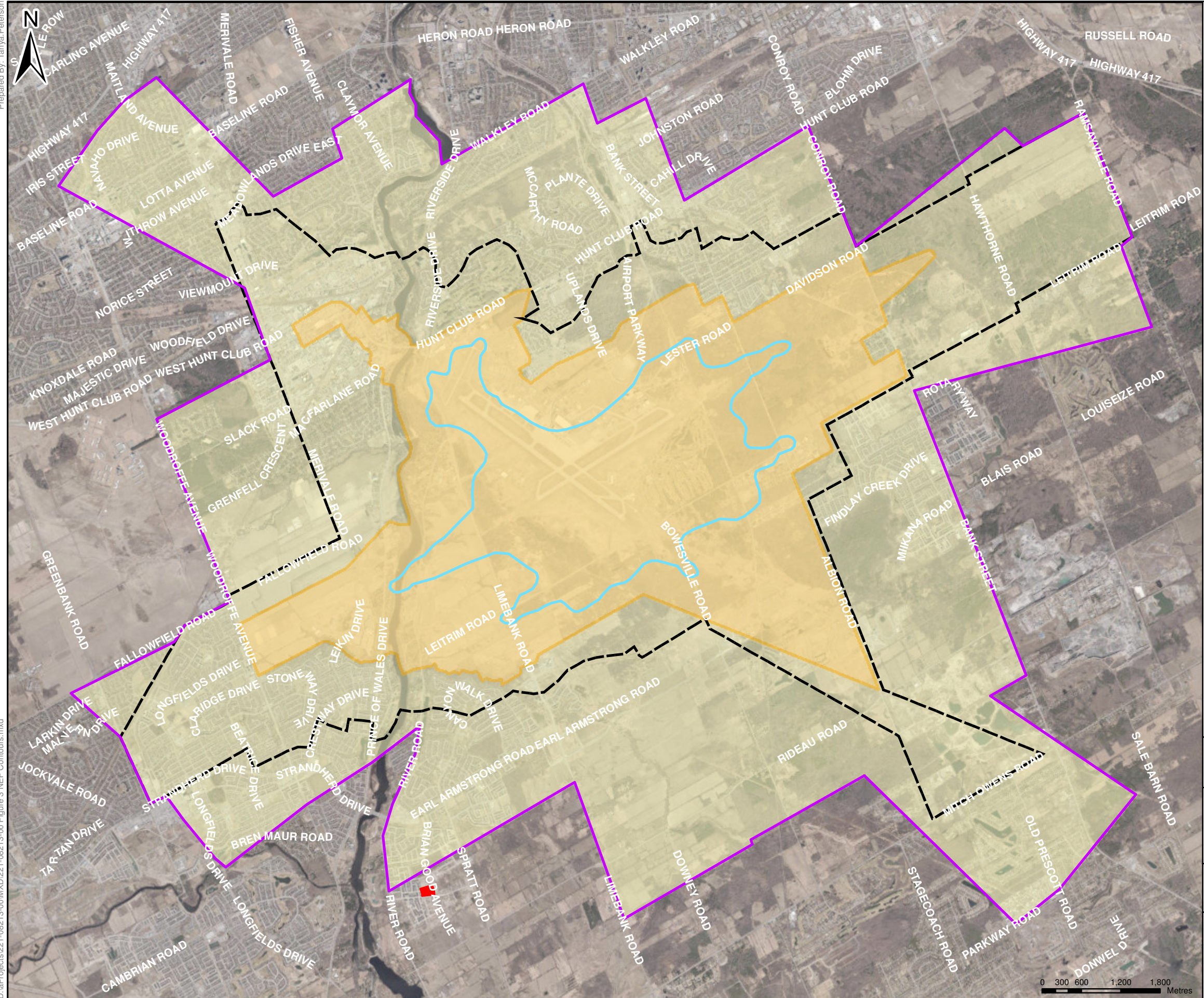

LEGEND:

■	SITE BOUNDARY
■	AIRPORT VICINITY DEVELOPMENT ZONE
	25 LINE (COMPOSITE OF 25 NEF/NEP)
	35 LINE NOISE EXPOSURE PROTECTION (NEP 2023)
	AIRPORT ZONING REGULATIONS
■	AIRPORT OPERATING INFLUENCING ZONE

TITLE: SITE LOCATION IN RELATION TO THE AIRPORTS NEF/NEP CONTOUR MAP

PROJECT: NOISE IMPACT STUDY
RIVERSIDE SOUTH ELEMENTARY SCHOOL
OTTAWA, ONTARIO

CLIENT: OCSB

 	PROJECT NO.:	REVIEWED BY:
	221-08213-00	CR
DATE:	FIGURE:	
AUGUST 2022	3	

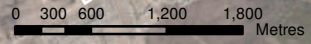



- LEGEND:
- SITE BOUNDARY
 - BUILDING
 - PORTABLES

TITLE:	SITE PLAN SHOWING PREDICTION LOCATIONS & ROAD SOURCES (TRANSPORTATION NOISE IMPACTS)	
PROJECT:	NOISE IMPACT STUDY RIVERSIDE SOUTH ELEMENTARY SCHOOL OTTAWA, ONTARIO	
CLIENT:	OCSB	

 GOLDER	PROJECT NO.:	221-08213-00	REVIEWED BY:	CR
	DATE:	AUGUST 2022	FIGURE:	4

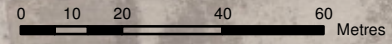

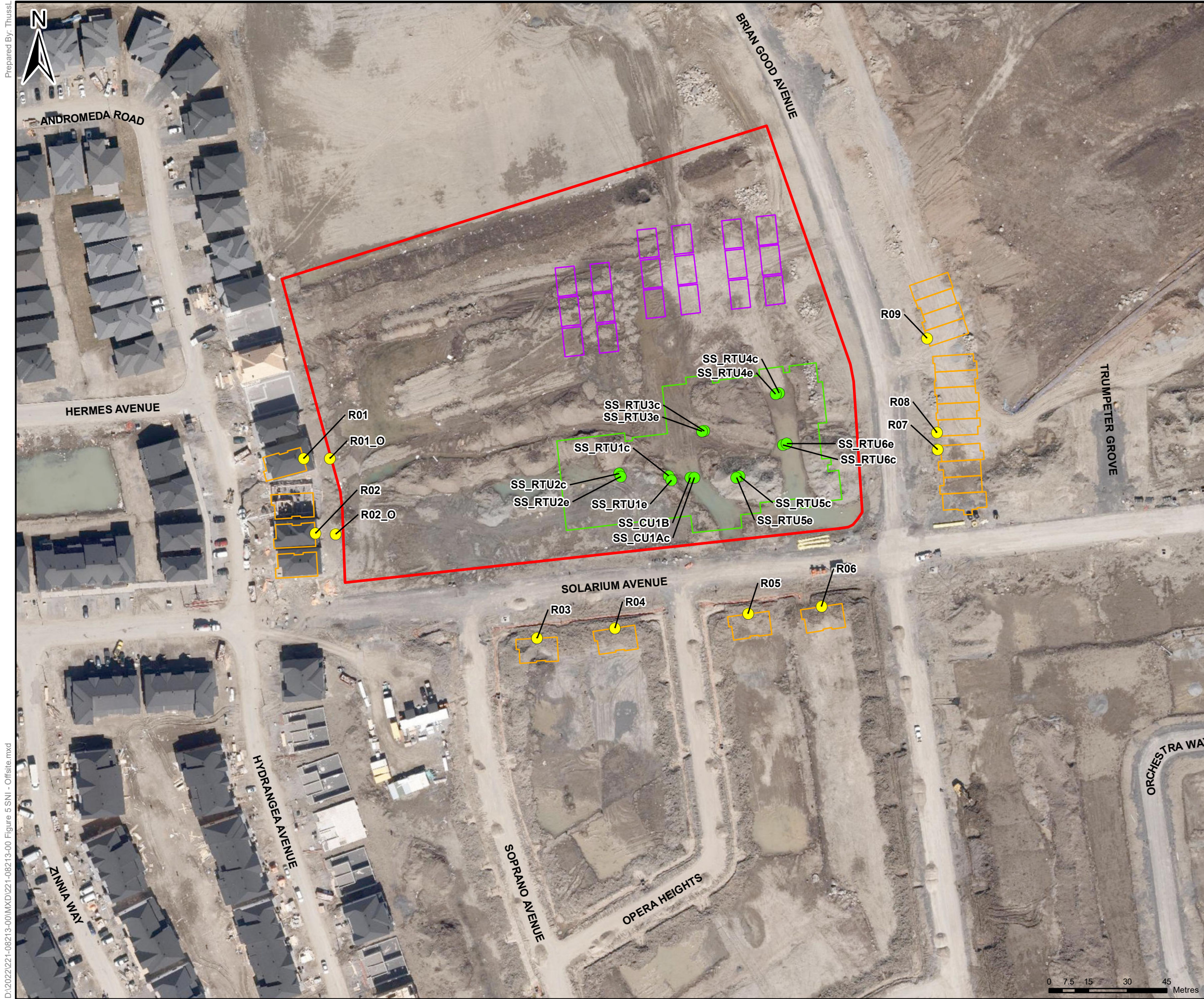

- LEGEND:
- RECEPTORS
 - SOURCE LOCATION
 - SITE BOUNDARY
 - BUILDING
 - RESIDENTIAL HOMES
 - PORTABLES

TITLE: SITE PLAN SHOWING ONSITE STATIONARY SOURCES & RECEPTOR LOCATIONS (STATIONARY NOISE IMPACTS OFFSITE)

PROJECT: NOISE IMPACT STUDY RIVERSIDE SOUTH ELEMENTARY SCHOOL OTTAWA, ONTARIO

CLIENT: OCSB

 GOLDER	PROJECT NO.:	REVIEWED BY:
	221-08213-00	CR
	DATE:	FIGURE:
	AUGUST 2022	5

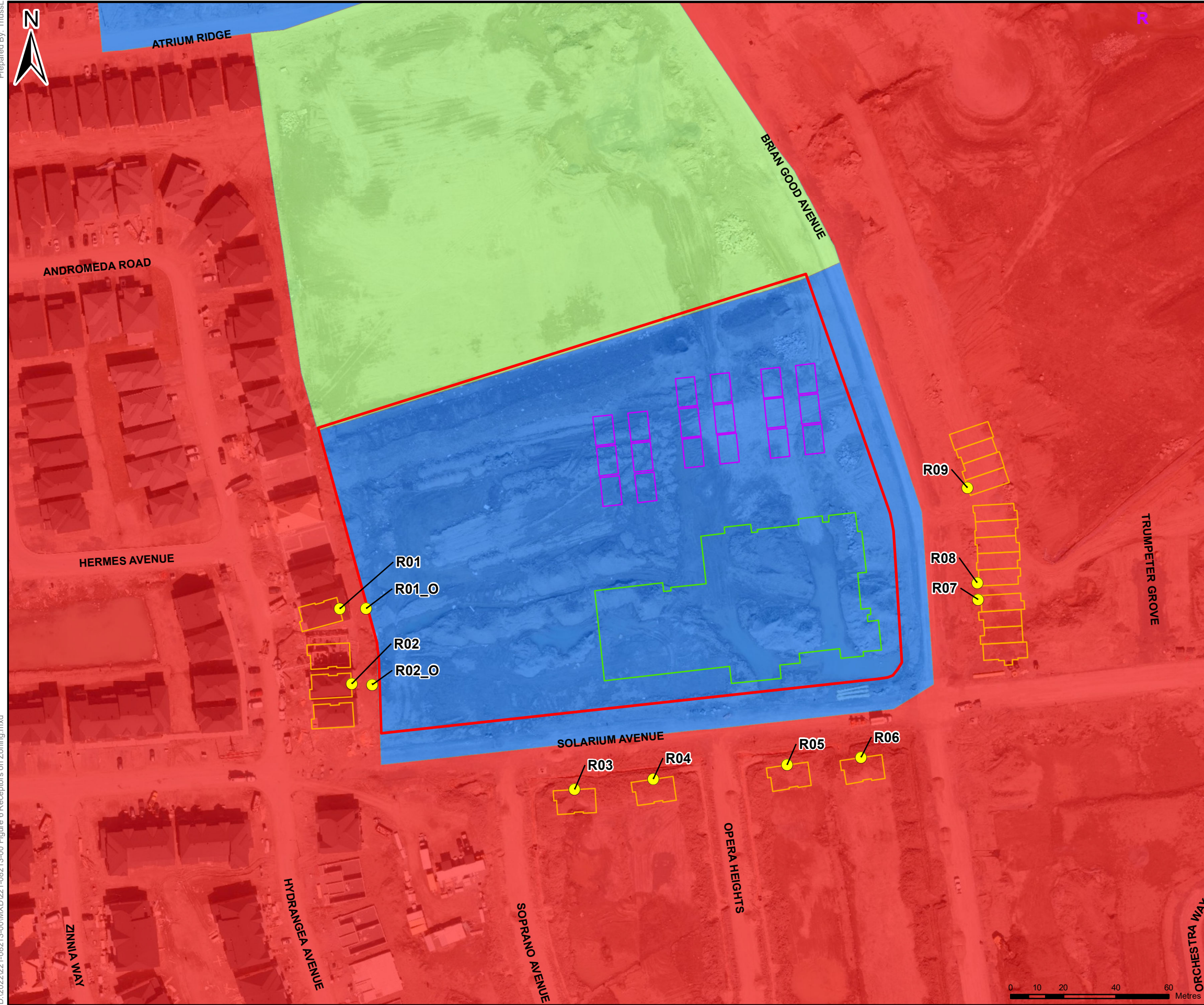

- LEGEND:
- RECEPTORS
 - SITE BOUNDARY
 - BUILDING
 - PORTABLES
 - INSTITUTIONAL
 - OPEN SPACE
 - RESIDENTIAL
 - RESIDENTIAL HOMES

TITLE:
RECEPTOR LOCATIONS ON ZONING MAP

PROJECT:
NOISE IMPACT STUDY
RIVERSIDE SOUTH ELEMENTARY SCHOOL
OTTAWA, ONTARIO

CLIENT:
OCSB

 GOLDER	PROJECT NO.: 221-08213-00	REVIEWED BY: CR
	DATE: AUGUST 2022	FIGURE: 6

APPENDIX

A DRAWINGS



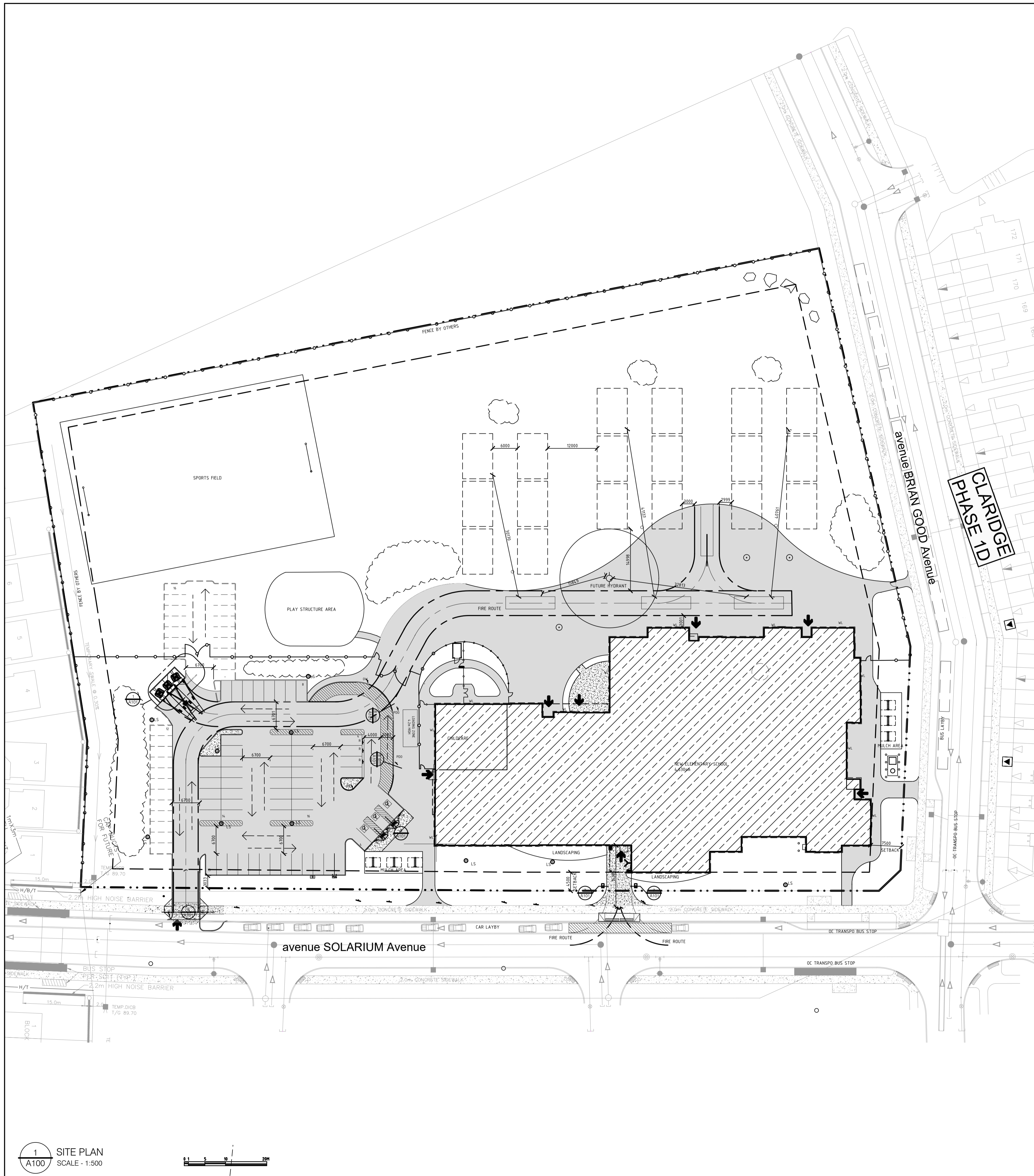

1 SITE PLAN
A100 SCALE - 1:500

ZONING REQUIREMENTS			
Municipality	City of Ottawa		
Legal Description	City of Ottawa		
xxxxx	City of Ottawa		
Survey Information			
Survey Information Prepared By:	Annis O'Sullivan Vollebek Ltd		
xxxx			
Common Address			
Corner of Brian Good Ave & Solarium Ave	Ottawa,	Ontario	
Project Information			
Lot Size	27,434sm		
Gross Building Floor Area	4,630sm		
Zoning	I1A/R4Z	Institutional 1	
	Bylaw Provisions	Proposed	Compliance
Minimum Lot Width	15m	xm	Complies
Minimum Lot Area	400 sm	xsm	Complies
Minimum Front Yard Setback	7.5m	xm	Complies
Minimum Rear Yard Setback	7.5m	xm	Complies
Minimum Interior Side Yard Setback	7.5m	xm	Complies
Minimum Corner Side Yard Setback	4.5m	xm	Complies
Maximum Building Height	15.0m	7.65m	Complies
Required Parking (Schedule 1A - Area C) Rate = 1.5 per classroom (includes 16 classrooms + 6 kindergartens) Childcare 1/50sm	1.5 x 22 classrooms = 33 Spaces + 275sm Childcare/50sm = 6 Spaces 39 Total spaces required	59 Spaces Proposed	Complies
Future Parking (12 future portables)	1.5 x 18 portables = 27 additional Spaces total (27 + 39) = 66 Spaces	28 Future Spaces total (59 + 28) = 87	Complies
HC Parking Requirements	Based on 50 parking spaces provided	2 HC Spaces Required 1 @ type A 1 @ type B	Complies
Required Bicycle Parking (1/100sm Gross Floor Area) Required Loading Zones = 1 per 1000-9999 sm of gross floor area	1/100sm X4,647sm = 47 spaces required 1 Loading Zone = 3.5m(W) X 7m (L) x 4.2m (H) As per zoning Section 113 (4) & (5)	48 spaces (6 Bike Racks @ 8 spaces) 1	Complies
Minimum Width of Landscaped Area (Landscape Buffer)	Abutting A Street = 3.0m Abutting residential, institutional = 3.0m Other Cases - None	4.0m N/A	Complies
Landscaped Provisions for Parking Lots	Landscape buffer width: 3m abutting a street, 1.5m not abutting a street Refuse collection areas must be minimum 9.0m from property line abutting a street Refuse collection areas must be minimum 3.0m from other property lines Refuse collection area must be screened with minimum 2.0m height screen	4m 2.15m	Complies
Minimum landscaped area of parking lot = 15% Landscape around Parking = 478sm = >15%	Parking Lot Area = 1782sm Landscape around Parking = 478sm = >15%		

ZONING INFORMATION

CONTEXT MAP	
PROJECT NO. 22022	DRAWING NO. A100-A
SCALE - AS NOTED	
DRAWN - I.R.	
CHECKED - I.R.	
PLOT DATE - 06/07/2022	PLOTTED BY: IR



REV	REVISION DESCRIPTION	DATE
3	ISSUED FOR CLIENT REVIEW	4/JUL/2022
2	ISSUED FOR CLIENT REVIEW	23/JUN/2022
1	ISSUED FOR CLIENT REVIEW	31/MAY/2022

THIS DRAWING IS THE EXCLUSIVE PROPERTY OF PYE & RICHARDS - TEMPRANO & YOUNG ARCHITECTS INC. COPYRIGHT RESERVED.
CONTRACTOR TO VERIFY ALL DIMENSIONS AND NOTIFY THE ARCHITECT OF ANY DIMENSIONAL ERRORS AND/OR POSSIBLE TRADE INTERFERENCE/CONFLICT FOR CLARIFICATION PRIOR TO COMMENCEMENT OF THE WORK. DO NOT SCALE DRAWINGS.

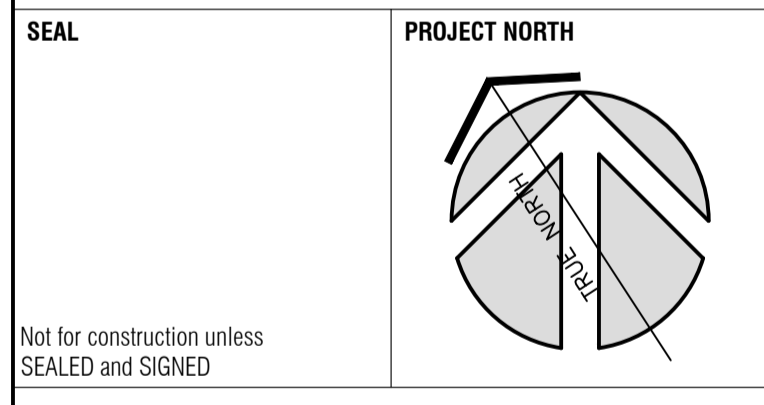

Not for construction unless SEALED and SIGNED

P R PYE & RICHARDS - TEMPRANO & YOUNG ARCHITECTS INC.
T Y

824 Meath St. Suite 200 613. 724. 7700
Ottawa, ON K1Z 6E8 info@prty.ca

PROJECT
OCSB RIVERSIDE SOUTH ELEMENTARY SCHOOL

CORNER OF BRIAN GOOD AVE & SOLARIUM AVE OTTAWA, ONTARIO

DRAWING
SITE PLAN - OPTION A
ZONING MATRIX

APPENDIX

B TRAFFIC DATA



Appendix B: Table of Traffic and Road Parameters To Be Used For Sound Level Predictions

Table B1 Traffic And Road Parameters To Be Used For Sound Level Predictions

Row Width (m)	Implied Roadway Class	AADT Vehicles/Day	Posted Speed Km/Hr	Day/Night Split %	Medium Trucks %	Heavy Trucks % ¹
NA ²	Freeway, Queensway, Highway	18,333 per lane	100	92/8	7	5
37.5-44.5	6-Lane Urban Arterial-Divided (6 UAD)	50,000	50-80	92/8	7	5
34-37.5	4-Lane Urban Arterial-Divided (4-UAD)	35,000	50-80	92/8	7	5
23-34	4-Lane Urban Arterial-Undivided (4-UAU)	30,000	50-80	92/8	7	5
23-34	4-Lane Major Collector (4-UMCU)	24,000	40-60	92/8	7	5
30-35.5	2-Lane Rural Arterial (2-RAU)	15,000	50-80	92/8	7	5
20-30	2-Lane Urban Arterial (2-UAU)	15,000	50-80	92/8	7	5
20-30	2-Lane Major Collector (2-UMCU)	12,000	40-60	92/8	7	5
30-35.5	2-Lane Outer Rural Arterial (near the extremities of the City) (2-RAU)	10,000	50-80	92/8	7	5
20-30	2-Lane Urban Collector (2-UCU)	8,000	40-50	92/8	7	5

¹ The MOE Vehicle Classification definitions should be used to estimate automobiles, medium trucks and heavy trucks.

² The number of lanes is determined by the future mature state of the roadway.

Note:
 1) This schedule forms part of the Official Plan of the City of Ottawa and must be read in conjunction with the text.
 2) This schedule is intended as a framework for planning and design; consequently alignments of proposed roads are approximate and subject to detailed study.
 3) An unidentified new facility from Highway 416 to Highway 417 East is not shown.

Note:
 1) La présente annexe fait partie du Plan officiel de la Ville d'Ottawa et doit être consultée en se reportant au texte même du Plan officiel.
 2) La présente annexe doit servir de guide en matière de planification et de conception; il s'ensuit que le tracé des routes proposées n'est qu'approximatif et donnera lieu à une étude plus approfondie.
 3) Une nouvelle installation non identifiée et située entre l'autoroute 416 et l'autoroute 417E n'apparaît pas.

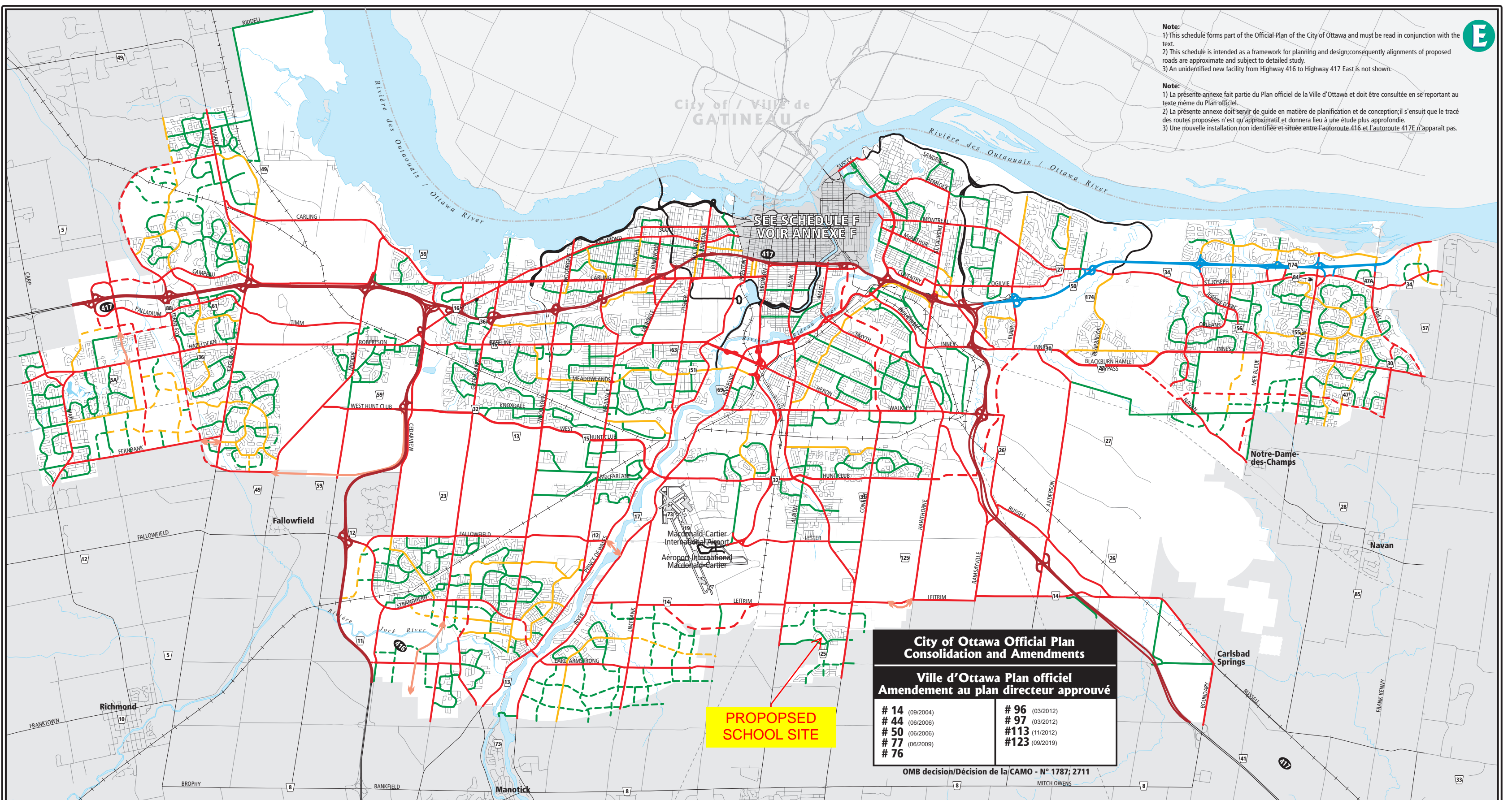

SEE SCHEDULE F
 VOIR ANNEXE F

PROPOSED
 SCHOOL SITE

City of Ottawa Official Plan Consolidation and Amendments
Ville d'Ottawa Plan officiel Amendement au plan directeur approuvé

# 14 (09/2004)	# 96 (03/2012)
# 44 (06/2006)	# 97 (03/2012)
# 50 (06/2006)	# 113 (11/2012)
# 77 (06/2009)	# 123 (09/2019)
# 76	

OMB decision/Décision de la CAMO - N° 1787; 2711

**Official Plan - Schedule E
 Urban Road Network**
 Plan officiel - Annexe E
 Routes Arterial - Urbain

Prepared by: Planning and Growth Management Department, Mapping & Graphics Unit

Préparé par : Service de l'urbanisme et de la gestion de la croissance, Unité de la cartographie et des graphiques

Provincial Highway City Freeway	Route provinciale Autoroute de ville	Arterials Existing Proposed Conceptual (Alignment Undefined)	Artère Établie Proposé Conceptuelle (Alignement à déterminée)	Major Collectors Existing Proposed	Grande collectrice Établie Proposé
Federally Owned Road Existing Proposed (Alignment defined)	Chemins de propriété fédéral Établie Proposé (Alignement déterminée)			Collectors Existing Proposed	Collectrice Établie Proposé

APPENDIX

C NEF/NEP

CONTOUR MAP



OFFICIAL PLAN - ANNEX 10

Land Use Constraints Due to Aircraft Noise





Prepared by: City of Ottawa,
Department of Planning, Transit and the Environment,
September 2011

PLAN OFFICIEL - APPENDICE 10

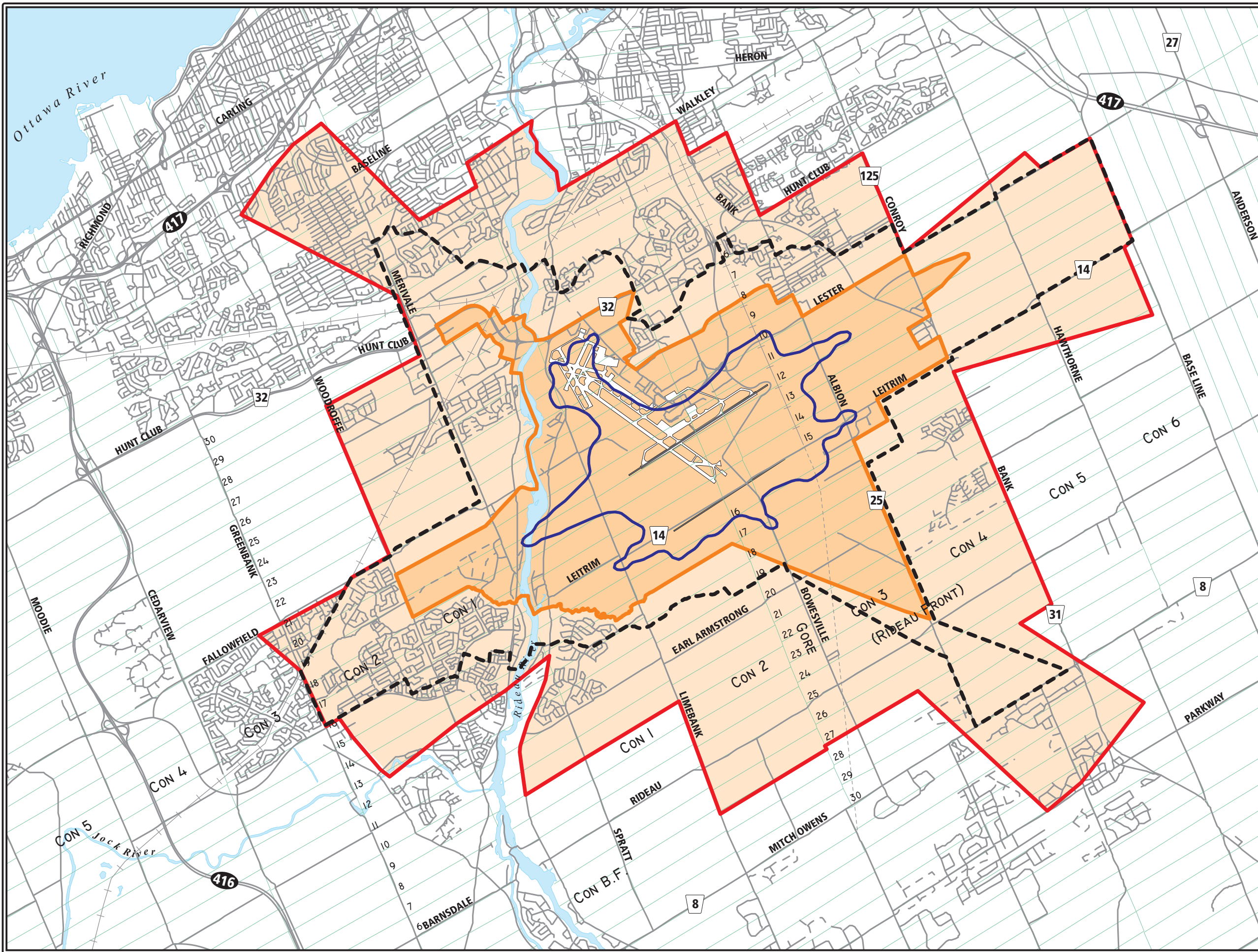
Contraintes limitant l'utilisation en raison du bruit des avions

Préparé par : Ville d'Ottawa,
Le Service de l'urbanisme, du transport en commun et de l'environnement,
septembre 2011



-  Airport Vicinity Development Zone
Zone d'aménagement dans le voisinage de l'aéroport
-  25 Line (Composite of 25 NEF/NEP)
Ligne 25 (ensemble des courbes NEF et NEP 25)
-  35 Line Noise Exposure Protection (NEP 2023)
Ligne 35 : prévisions à long terme de l'ambiance sonore (NEP 2023)
-  Airport Zoning Regulations
Règlements de zonage applicables à de l'Aéroport
-  Airport Operating Influence Zone
Zone d'influence d'exploitation de l'aéroport

Note:
The boundaries of the Ottawa Airport Operating Influence Zone and the Airport Vicinity Development Zone, are not subject to interpretation and their precise locations should be read from a map at a scale of 1:50,000 available from the City of Ottawa and the Ottawa International Airport Authority.

Scale / Échelle
1km 0 1 2 3 km



APPENDIX

D STAMSON VALIDATION FILES

Filename: V1.te Time Period: 16 hours
Description: V1 Validation

Road data, segment # 1: Solarium

Car traffic volume : 6477 veh/TimePeriod *
Medium truck volume : 515 veh/TimePeriod *
Heavy truck volume : 368 veh/TimePeriod *
Posted speed limit : 40 km/h
Road gradient : 0 %
Road pavement : 1 (Typical asphalt or concrete)

Data for Segment # 1: Solarium

Angle1 Angle2 : -90.00 deg 90.00 deg
Wood depth : 0 (No woods.)
No of house rows : 0
Surface : 2 (Reflective ground surface) Receiver source distance : 17.50 m
Receiver height : 1.50 m
Topography : 1 (Flat/gentle slope; no barrier) Reference angle : 0.00

Road data, segment # 2: Brian Good

Car traffic volume : 6477 veh/TimePeriod *
Medium truck volume : 515 veh/TimePeriod *
Heavy truck volume : 368 veh/TimePeriod *
Posted speed limit : 40 km/h
Road gradient : 0 %
Road pavement : 1 (Typical asphalt or concrete)

Data for Segment # 2: Brian Good

Angle1 Angle2 : 0.00 deg 27.00 deg
Wood depth : 0 (No woods.)
No of house rows : 0
Surface : 2 (Reflective ground surface) Receiver source distance : 68.00 m
Receiver height : 1.50 m
Topography : 1 (Flat/gentle slope; no barrier) Reference angle : 0.00

Road data, segment # 3: Brian Good 2

Car traffic volume : 6477 veh/TimePeriod *
Medium truck volume : 515 veh/TimePeriod * Heavy truck volume : 368 veh/
TimePeriod *
Posted speed limit : 40 km/h
Road gradient : 0 %
Road pavement : 1 (Typical asphalt or concrete)

Data for Segment # 3: Brian Good 2

Angle1 Angle2 : 27.00 deg 70.00 deg
Wood depth : 0 (No woods.)
No of house rows : 1
House density : 45 %
Surface : 1 (Absorptive ground surface) Receiver source distance : 68.00 m
Receiver height : 1.50 m
Topography : 1 (Flat/gentle slope; no barrier) Reference angle : 0.00

Results segment # 1: Solarium

Source height = 1.50 m

ROAD (0.00 + 63.29 + 0.00) = 63.29 dBA
Angle1 Angle2 Alpha RefLeq P.Adj D.Adj F.Adj W.Adj H.Adj B.Adj SubLeq -----
----- -90 90
0.00 63.96 0.00 -0.67 0.00 0.00 0.00 0.00 63.29 -----

Segment Leq : 63.29 dBA

Results segment # 2: Brian Good

Source height = 1.50 m

ROAD (0.00 + 49.15 + 0.00) = 49.15 dBA
Angle1 Angle2 Alpha RefLeq P.Adj D.Adj F.Adj W.Adj H.Adj B.Adj SubLeq -----
----- 0 27
0.00 63.96 0.00 -6.56 -8.24 0.00 0.00 0.00 49.15 -----

Segment Leq : 49.15 dBA

Results segment # 3: Brian Good 2

Source height = 1.50 m

ROAD (0.00 + 43.17 + 0.00) = 43.17 dBA
Angle1 Angle2 Alpha RefLeq P.Adj D.Adj F.Adj W.Adj H.Adj B.Adj SubLeq -----
----- 27 70
0.66 63.96 0.00 -10.90 -7.50 0.00 -2.39 0.00 43.17 -----

Segment Leq : 43.17 dBA

Total Leq All Segments: 63.49 dBA

TOTAL Leq FROM ALL SOURCES: 63.49

Filename: v2.te Time Period: 16 hours
Description: V2 Validation

Road data, segment # 1: Brian Good

Car traffic volume : 6477 veh/TimePeriod *
Medium truck volume : 515 veh/TimePeriod *
Heavy truck volume : 368 veh/TimePeriod *
Posted speed limit : 40 km/h
Road gradient : 0 %
Road pavement : 1 (Typical asphalt or concrete)

Data for Segment # 1: Brian Good

Angle1 Angle2 : -90.00 deg 90.00 deg
Wood depth : 0 (No woods.)
No of house rows : 0
Surface : 1 (Absorptive ground surface) Receiver source distance : 22.00 m
Receiver height : 1.50 m
Topography : 1 (Flat/gentle slope; no barrier) Reference angle : 0.00

Road data, segment # 2: Solarium 1

Car traffic volume : 1600 veh/TimePeriod
Medium truck volume : 320 veh/TimePeriod
Heavy truck volume : 160 veh/TimePeriod
Posted speed limit : 40 km/h
Road gradient : 0 %
Road pavement : 1 (Typical asphalt or concrete)

Data for Segment # 2: Solarium 1

Angle1 Angle2 : -20.00 deg -10.00 deg
Wood depth : 0 (No woods.)
No of house rows : 0
Surface : 1 (Absorptive ground surface) Receiver source distance : 61.00 m
Receiver height : 1.50 m
Topography : 1 (Flat/gentle slope; no barrier) Reference angle : 0.00

Road data, segment # 3: Solarium 2

Car traffic volume : 6477 veh/TimePeriod *
Medium truck volume : 515 veh/TimePeriod * Heavy truck volume : 368 veh/
TimePeriod *
Posted speed limit : 40 km/h
Road gradient : 0 %
Road pavement : 1 (Typical asphalt or concrete)

Data for Segment # 3: Solarium 2

Angle1 Angle2 : -60.00 deg -30.00 deg
Wood depth : 0 (No woods.)
No of house rows : 1
House density : 45 %
Surface : 2 (Reflective ground surface) Receiver source distance : 61.00 m
Receiver height : 1.50 m
Topography : 1 (Flat/gentle slope; no barrier) Reference angle : 0.00

Results segment # 1: Brian Good

Source height = 1.50 m

ROAD (0.00 + 59.74 + 0.00) = 59.74 dBA
Angle1 Angle2 Alpha RefLeq P.Adj D.Adj F.Adj W.Adj H.Adj B.Adj SubLeq -----
----- -90 90
0.66 63.96 0.00 -2.76 -1.46 0.00 0.00 0.00 59.74 -----

Segment Leq : 59.74 dBA

Results segment # 2: Solarium 1

Source height = 1.67 m

ROAD (0.00 + 37.67 + 0.00) = 37.67 dBA
Angle1 Angle2 Alpha RefLeq P.Adj D.Adj F.Adj W.Adj H.Adj B.Adj SubLeq -----
----- -20 -
10 0.66 60.41 0.00 -10.08 -12.66 0.00 0.00 0.00 37.67 -----

Segment Leq : 37.67 dBA

Results segment # 3: Solarium 2

Source height = 1.50 m

ROAD (0.00 + 47.68 + 0.00) = 47.68 dBA
Angle1 Angle2 Alpha RefLeq P.Adj D.Adj F.Adj W.Adj H.Adj B.Adj SubLeq -----
----- -60 -
30 0.00 63.96 0.00 -6.09 -7.78 0.00 -2.40 0.00 47.68 -----

Segment Leq : 47.68 dBA

Total Leq All Segments: 60.03 dBA

TOTAL Leq FROM ALL SOURCES: 60.03

APPENDIX

E SUPPORTING INFORMATION



AAON Standard Condenser Fan Radiated Sound Levels

Updated 10/26/2018

		Fans Dia RPM		Sound Power Level								Sound Pressure Level in a Hemispherical Free Field								Dist (ft) 5		
												Sound Pressure Level										
				63	125	250	500	1000	2000	4000	8000	LwA	63	125	250	500	1000	2000	4000		8000	dBA
RQ 2 & 3 Ton	Inlet	1	30	850	79	74	72	70	66	62	59	59	72	68	62	60	58	54	51	48	47	60
	Outlet				81	77	71	71	67	62	59	58	73	69	66	59	59	55	51	48	46	61
	Total				83	79	74	73	69	65	62	61	75	72	67	63	62	58	54	51	50	63
RQ 4-6 Ton & RN 6 & 7 Ton	Inlet	1	30	1085	85	79	77	75	71	68	65	64	77	73	67	66	63	59	56	53	52	65
	Outlet				86	83	76	76	72	68	65	63	78	75	71	64	65	60	56	53	52	66
	Total				89	84	80	79	75	71	68	67	80	77	73	68	67	63	59	56	55	69
RN 8 & 10 Ton	Inlet	1	30	1085	92	86	85	82	78	75	72	71	84	80	75	73	70	66	63	60	60	73
	Outlet				94	90	83	83	79	75	72	71	85	82	78	71	72	68	63	60	59	73
	Total				96	91	87	86	82	78	75	74	88	84	80	75	74	70	66	63	62	76
RN 09 & 11 Ton	Inlet	2	30	1085	88	82	80	78	74	71	68	67	80	76	70	69	66	62	59	56	55	68
	Outlet				89	86	79	79	75	71	68	66	81	78	74	67	68	63	59	56	55	69
	Total				92	87	83	82	78	74	71	70	83	80	76	71	70	66	62	59	58	72
RN 13-20 Ton	Inlet	2	30	1085	95	89	88	85	81	78	75	74	87	83	78	76	73	69	66	63	63	76
	Outlet				97	93	86	86	82	78	75	74	88	85	81	74	75	71	66	63	62	76
	Total				99	94	90	89	85	81	78	77	91	87	83	78	77	73	69	66	65	79
RN 25 & 30 Ton	Inlet	3	30	1085	97	91	89	87	83	80	77	76	89	85	79	78	75	71	68	65	64	77
	Outlet				98	95	88	88	84	80	77	75	90	87	83	76	76	72	68	65	64	78
	Total				101	96	92	91	86	83	80	79	92	89	85	80	79	75	71	68	67	81
RN 26,31 & 40 Ton	Inlet	4	30	1085	98	92	91	88	84	81	78	77	90	86	81	79	76	72	69	66	66	79
	Outlet				100	96	89	89	85	81	78	77	91	88	84	77	78	74	69	66	65	79
	Total				102	98	93	92	88	84	81	80	94	90	86	81	80	76	72	69	68	82
RN 50,60 & 70 Ton	Inlet	6	30	1085	100	94	92	90	86	83	80	79	92	88	82	81	78	74	71	68	67	80
	Outlet				101	98	91	91	87	83	80	78	93	90	86	79	79	75	71	68	67	81
	Total				104	99	95	94	89	86	83	82	95	92	88	83	82	78	74	71	70	84
RN E 55,65 & 75 Ton LN & LZ 45-60 Ton RZ 45-75	Inlet	4	30	1170	92	86	87	87	86	85	85	78	92	80	74	75	75	74	73	73	66	80
	Outlet				92	86	87	87	86	85	85	78	92	80	74	75	75	74	73	73	66	80
	Total				95	89	90	90	89	88	88	81	95	83	77	78	78	77	76	76	69	83
RN E 90-140 Ton LN & LZ 75-140 Ton RZ 90-140	Inlet	8	30	1170	95	89	90	90	89	88	88	81	95	83	77	78	78	77	76	76	69	83
	Outlet				95	89	90	90	89	88	88	81	95	83	77	78	78	77	76	76	69	83
	Total				98	92	93	93	92	91	91	84	98	86	80	81	81	80	79	79	72	86
RZ 145-180	Inlet	12	30	1170	97	91	92	92	91	90	90	83	97	85	79	80	80	79	78	78	71	85
	Outlet				97	91	92	92	91	90	90	83	97	85	79	80	80	79	78	78	71	85
	Total				100	94	95	95	94	93	93	86	100	88	82	83	83	82	81	81	74	88
RZ 200-240	Inlet	16	30	1170	98	92	93	93	92	91	91	84	98	86	80	81	81	80	79	79	72	86
	Outlet				98	92	93	93	92	91	91	84	98	86	80	81	81	80	79	79	72	86
	Total				101	95	96	96	95	94	94	87	101	89	83	84	84	83	82	82	75	89

Tested in Accordance with AMCA 300 - Updated 6-15-15



15.0" STAR Plenum

2425 South Yukon Ave - Tulsa, Oklahoma 74107-2728 - Ph. (918) 583-2266 Fax (918) 583-6094
AAONEcat32 Ver. 4.324 (SN: 6114768-C4GU4Q4U)

JOB INFORMATION:

Job Name: CEPEO Kanata
Job Tag: RTU-1 Daycare
Rep Firm:
Date: 07-07-2022

WHEEL SPECIFICATION:

Max RPM: 2,200
Diameter x Qty: 15.0 in. x 1
CFM: 3200
Tip Speed: 7,846 FPM
Inertia: 3 WR²

OPERATING CONDITIONS:

Air Flow: 3,200 CFM
Static Pressure: 0.98 in. Wg.
Relief Dampers DP: 0.44 in. Wg.

TSP: 1.42 in. Wg.
Site Altitude: 0.00 Ft
TSP @ Sea Level: 1.42 in. Wg.

MOTOR SELECTION:

Rated HP / Bypass: 2 / No
Frame Size: 145T
Nominal RPM: 1760
VAC/PH/HZ: 575/3/60
Efficiency: Premium / 0.865
Enclosure Type: ODP
Max Inertial Load: 27 WR²

FAN PERFORMANCE:

RPM: 1998
BHP: 1.51
Efficiency: 47.4%
In/Out Velocity: 1624/1260 FPM
Plenum Out Velocity: 53 FPM

FAN SOUND POWER (Inlet/Outlet):

Octave Band:	(Re 10 ⁻¹² watts)							
	1	2	3	4	5	6	7	8
	85	86	86	86	80	76	74	70
	85	86	86	86	80	76	74	70

SOUND POWER A-Weighted: 87 / 87 dB

Exhaust Fan Model: RM150 @ 1998 RPM and 100% Width
Design Conditions: 3200 CFM @ 1.43" SP

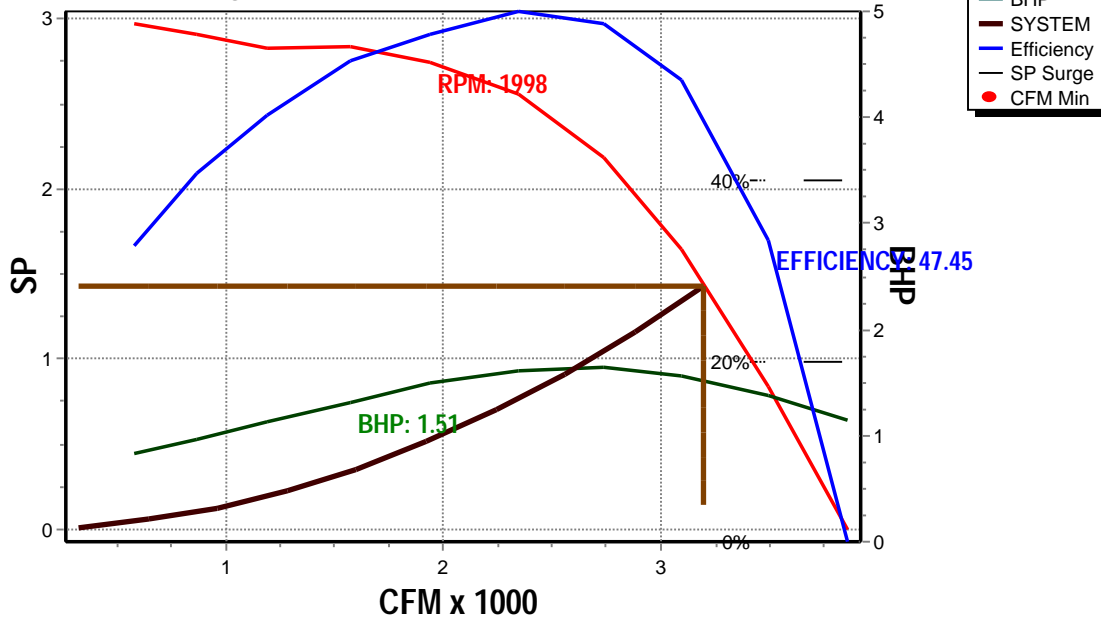



22.0" STAR Plenum

2425 South Yukon Ave - Tulsa, Oklahoma 74107-2728 - Ph. (918) 583-2266 Fax (918) 583-6094
AAONEcat32 Ver. 4.324 (SN: 6114768-C4GU4Q4U)

JOB INFORMATION:

Job Name: CEPEO Kanata
 Job Tag: RTU-2 Kindergarten
 Rep Firm: Classrooms
 Date: 07-07-2022

WHEEL SPECIFICATION:

Max RPM: 2,200
 Diameter x Qty: 22.0 in. x 1
 CFM:
 Tip Speed: 6100
 Inertia: 7,914 FPM
 5 WR²

OPERATING CONDITIONS:

Air Flow: 6,100 CFM
 Static Pressure: 0.83 in. Wg.
 Relief Dampers DP: 0.43 in. Wg.
 TSP: 1.26 in. Wg.
 Site Altitude: 0.00 Ft
 TSP @ Sea Level: 1.26 in. Wg.

MOTOR SELECTION:

Rated HP / Bypass: 5 / No
 Frame Size: 184T
 Nominal RPM: 1760
 VAC/PH/HZ: 575/3/60
 Efficiency: Premium / 0.895
 Enclosure Type: ODP
 Max Inertial Load: 52 WR²

FAN PERFORMANCE:

RPM: 1374
 BHP: 3.33
 Efficiency: 36.4%
 In/Out Velocity: 1865/2054 FPM
 Plenum Out Velocity: 102 FPM

FAN SOUND POWER (Inlet/Outlet):

Octave Band:	(Re 10 ⁻¹² watts)							
	1	2	3	4	5	6	7	8
	89	88	90	85	79	78	73	65
	89	88	90	85	79	78	73	65

SOUND POWER A-Weighted: 90 / 90 dB

Exhaust Fan Model: RM220A @ 1374 RPM and 100% Width
 Design Conditions: 6100 CFM @ 1.26" SP

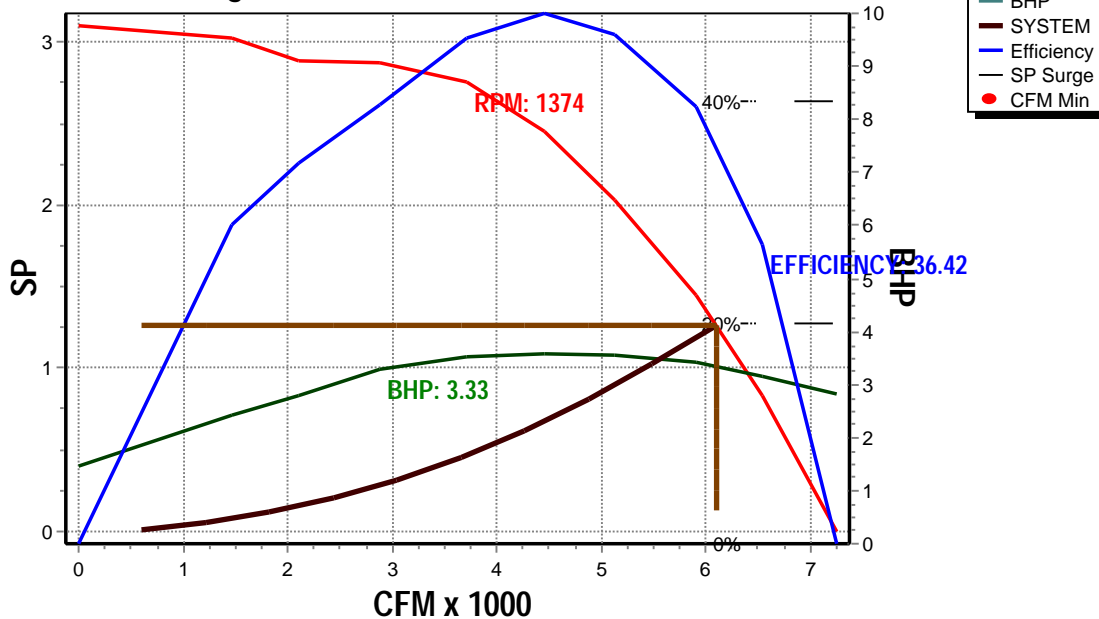



18.5" STAR Plenum

2425 South Yukon Ave - Tulsa, Oklahoma 74107-2728 - Ph. (918) 583-2266 Fax (918) 583-6094
AAONEcat32 Ver. 4.324 (SN: 6114768-C4GU4Q4U)

JOB INFORMATION:

Job Name: CEPEO Kanata
 Job Tag: RTU-3 Library and
 Rep Firm: Multipurpose
 Date: 07-07-2022

WHEEL SPECIFICATION:

Max RPM: 2,200
 Diameter x Qty: 18.5 in. x 1
 CFM:
 Tip Speed: 4100
 Inertia: 6,601 FPM
 3 WR²

OPERATING CONDITIONS:

Air Flow: 4,100 CFM
 Static Pressure: 1.02 in. Wg.
 Relief Dampers DP: 0.26 in. Wg.
 TSP: 1.28 in. Wg.
 Site Altitude: 0.00 Ft
 TSP @ Sea Level: 1.28 in. Wg.

MOTOR SELECTION:

Rated HP / Bypass: 2 / No
 Frame Size: 145T
 Nominal RPM: 1760
 VAC/PH/HZ: 575/3/60
 Efficiency: Premium / 0.865
 Enclosure Type: ODP
 Max Inertial Load: 27 WR²

FAN PERFORMANCE:

RPM: 1363
 BHP: 1.39
 Efficiency: 59.5%
 In/Out Velocity: 2081/1614 FPM
 Plenum Out Velocity: 68 FPM

FAN SOUND POWER (Inlet/Outlet):

Octave Band:	(Re 10 ⁻¹² watts)							
	1	2	3	4	5	6	7	8
	84	84	83	81	75	72	69	64
	84	84	83	81	75	72	69	64

SOUND POWER A-Weighted: 85 / 85 dB

Exhaust Fan Model: RM185 @ 1363 RPM and 100% Width
 Design Conditions: 4100 CFM @ 1.28" SP

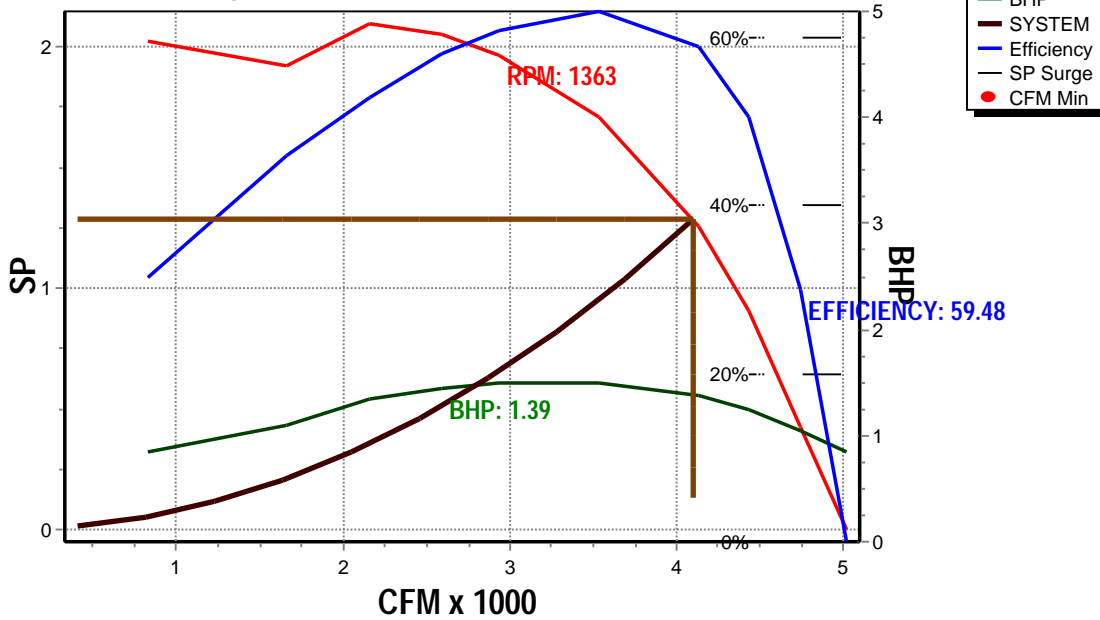



18.5" STAR Plenum

2425 South Yukon Ave - Tulsa, Oklahoma 74107-2728 - Ph. (918) 583-2266 Fax (918) 583-6094
AAONEcat32 Ver. 4.324 (SN: 6114768-C4GU4Q4U)

JOB INFORMATION:

Job Name: CEPEO Kanata
Job Tag: RTU-4 Admin
Rep Firm:
Date: 07-07-2022

WHEEL SPECIFICATION:

Max RPM: 2,200
Diameter x Qty: 18.5 in. x 1
CFM: 3650
Tip Speed: 5,822 FPM
Inertia: 3 WR²

OPERATING CONDITIONS:

Air Flow: 3,650 CFM
Static Pressure: 0.74 in. Wg.
Relief Dampers DP: 0.23 in. Wg.

TSP: 0.97 in. Wg.
Site Altitude: 0.00 Ft
TSP @ Sea Level: 0.97 in. Wg.

MOTOR SELECTION:

Rated HP / Bypass: 2 / No
Frame Size: 145T
Nominal RPM: 1760
VAC/PH/HZ: 575/3/60
Efficiency: Premium / 0.865
Enclosure Type: ODP
Max Inertial Load: 27 WR²

FAN PERFORMANCE:

RPM: 1202
BHP: 0.95
Efficiency: 58.9%
In/Out Velocity: 1853/1437 FPM
Plenum Out Velocity: 61 FPM

FAN SOUND POWER (Inlet/Outlet):

Octave Band:	(Re 10 ⁻¹² watts)							
	1	2	3	4	5	6	7	8
	80	81	81	76	72	69	65	60
	80	81	81	76	72	69	65	60

SOUND POWER A-Weighted: 81 / 81 dB

Exhaust Fan Model: RM185 @ 1202 RPM and 100% Width
Design Conditions: 3650 CFM @ 0.97" SP

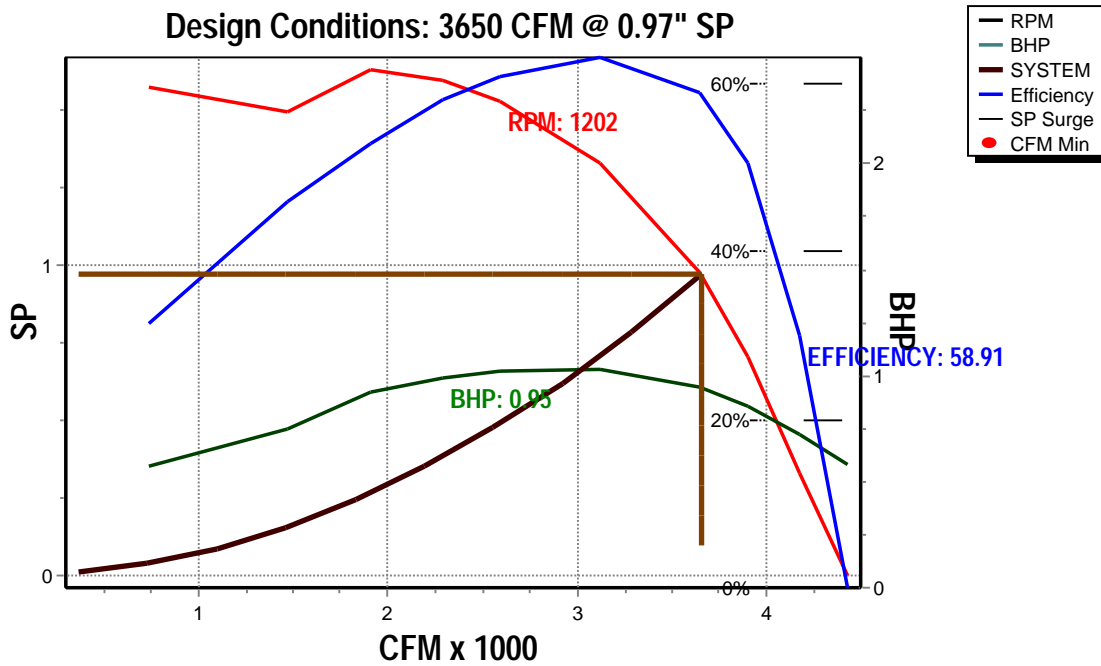



22.0" STAR Plenum

2425 South Yukon Ave - Tulsa, Oklahoma 74107-2728 - Ph. (918) 583-2266 Fax (918) 583-6094
AAONEcat32 Ver. 4.324 (SN: 6114768-C4GU4Q4U)

JOB INFORMATION:

Job Name: CEPEO Kanata
Job Tag: RTU-5 Gym
Rep Firm:
Date: 07-07-2022

WHEEL SPECIFICATION:

Max RPM: 2,200
Diameter x Qty: 22.0 in. x 1
CFM: 6200
Tip Speed: 7,862 FPM
Inertia: 5 WR²

OPERATING CONDITIONS:

Air Flow: 6,200 CFM
Static Pressure: 0.67 in. Wg.
Relief Dampers DP: 0.44 in. Wg.

TSP: 1.11 in. Wg.
Site Altitude: 0.00 Ft
TSP @ Sea Level: 1.11 in. Wg.

MOTOR SELECTION:

Rated HP / Bypass: 5 / No
Frame Size: 184T
Nominal RPM: 1760
VAC/PH/HZ: 575/3/60
Efficiency: Premium / 0.895
Enclosure Type: ODP
Max Inertial Load: 52 WR²

FAN PERFORMANCE:

RPM: 1365
BHP: 3.21
Efficiency: 33.8%
In/Out Velocity: 1896/2088 FPM
Plenum Out Velocity: 103 FPM

FAN SOUND POWER (Inlet/Outlet):

Octave Band:	(Re 10 ⁻¹² watts)							
	1	2	3	4	5	6	7	8
	89	88	90	85	79	78	73	65
	89	88	90	85	79	78	73	65

SOUND POWER A-Weighted: 90 / 90 dB

Exhaust Fan Model: RM220A @ 1365 RPM and 100% Width
Design Conditions: 6200 CFM @ 1.11" SP

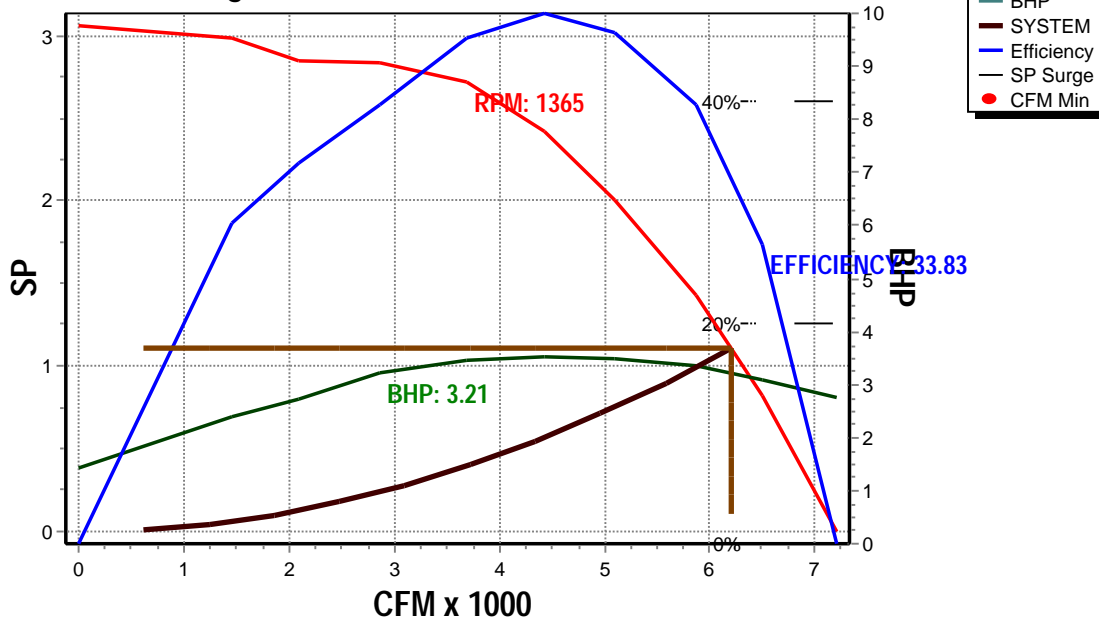



22.0" STAR Plenum

2425 South Yukon Ave - Tulsa, Oklahoma 74107-2728 - Ph. (918) 583-2266 Fax (918) 583-6094
AAONEcat32 Ver. 4.324 (SN: 6114768-C4GU4Q4U)

JOB INFORMATION:

Job Name: CEPEO Kanata
Job Tag: RTU-6 Ground East
Rep Firm:
Date: 07-07-2022

WHEEL SPECIFICATION:

Max RPM: 2,200
Diameter x Qty: 22.0 in. x 1
CFM: 6750
Tip Speed: 8,490 FPM
Inertia: 5 WR²

OPERATING CONDITIONS:

Air Flow: 6,750 CFM
Static Pressure: 0.74 in. Wg.
Relief Dampers DP: 0.50 in. Wg.

TSP: 1.24 in. Wg.
Site Altitude: 0.00 Ft
TSP @ Sea Level: 1.24 in. Wg.

MOTOR SELECTION:

Rated HP / Bypass: 5 / No
Frame Size: 184T
Nominal RPM: 1760
VAC/PH/HZ: 575/3/60
Efficiency: Premium / 0.895
Enclosure Type: ODP
Max Inertial Load: 52 WR²

FAN PERFORMANCE:

RPM: 1474
BHP: 4.02
Efficiency: 32.9%
In/Out Velocity: 2064/2273 FPM
Plenum Out Velocity: 112 FPM

FAN SOUND POWER (Inlet/Outlet):

Octave Band:	(Re 10 ⁻¹² watts)							
	1	2	3	4	5	6	7	8
	91	89	92	88	80	80	75	67
	91	89	92	88	80	80	75	67

SOUND POWER A-Weighted: 92 / 92 dB

Exhaust Fan Model: RM220A @ 1474 RPM and 100% Width
Design Conditions: 6750 CFM @ 1.24" SP

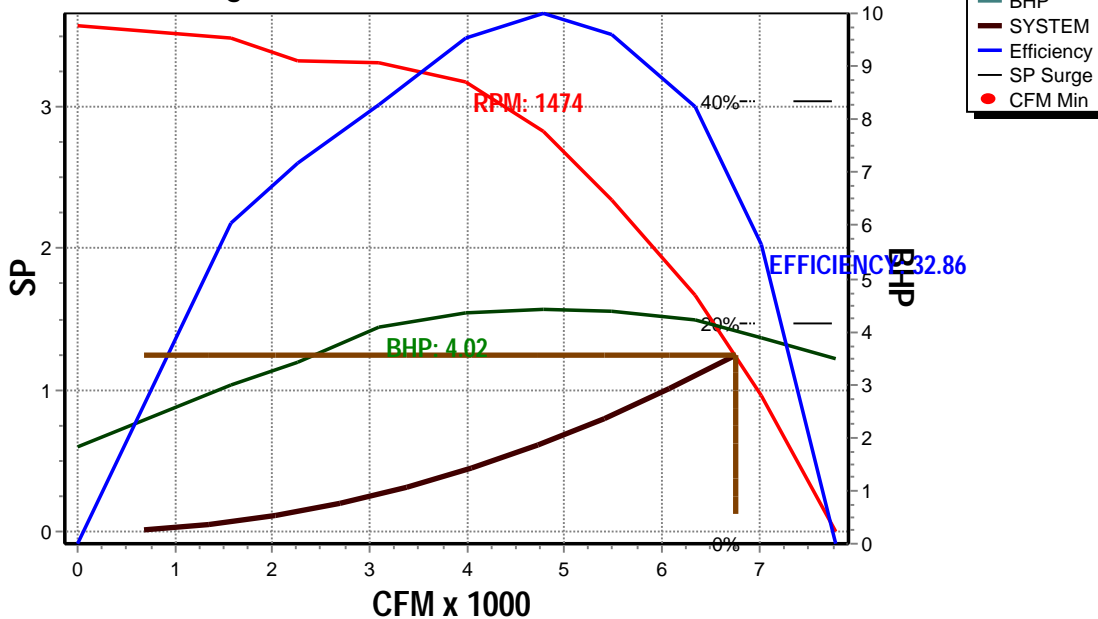



18.5" STAR Plenum

2425 South Yukon Ave - Tulsa, Oklahoma 74107-2728 - Ph. (918) 583-2266 Fax (918) 583-6094
AAONEcat32 Ver. 4.324 (SN: 6114768-C4GU4Q4U)

JOB INFORMATION:

Job Name: CEPEO Kanata
 Job Tag: RTU-7 Second Floor Zone 1
 Rep Firm:
 Date: 07-07-2022

WHEEL SPECIFICATION:

Max RPM: 2,200
 Diameter x Qty: 18.5 in. x 1
 CFM: 4400
 Tip Speed: 6,650 FPM
 Inertia: 3 WR²

OPERATING CONDITIONS:

Air Flow: 4,400 CFM
 Static Pressure: 0.64 in. Wg.
 Relief Dampers DP: 0.35 in. Wg.
 TSP: 0.99 in. Wg.
 Site Altitude: 0.00 Ft
 TSP @ Sea Level: 0.99 in. Wg.

MOTOR SELECTION:

Rated HP / Bypass: 2 / No
 Frame Size: 145T
 Nominal RPM: 1760
 VAC/PH/HZ: 575/3/60
 Efficiency: Premium / 0.865
 Enclosure Type: ODP
 Max Inertial Load: 27 WR²

FAN PERFORMANCE:

RPM: 1373
 BHP: 1.30
 Efficiency: 52.7%
 In/Out Velocity: 2234/1732 FPM
 Plenum Out Velocity: 73 FPM

FAN SOUND POWER (Inlet/Outlet):

Octave Band:	(Re 10 ⁻¹² watts)							
	1	2	3	4	5	6	7	8
	84	84	85	81	76	73	70	65
	84	84	85	81	76	73	70	65

SOUND POWER A-Weighted: 85 / 85 dB

Exhaust Fan Model: RM185 @ 1373 RPM and 100% Width
 Design Conditions: 4400 CFM @ 0.99" SP

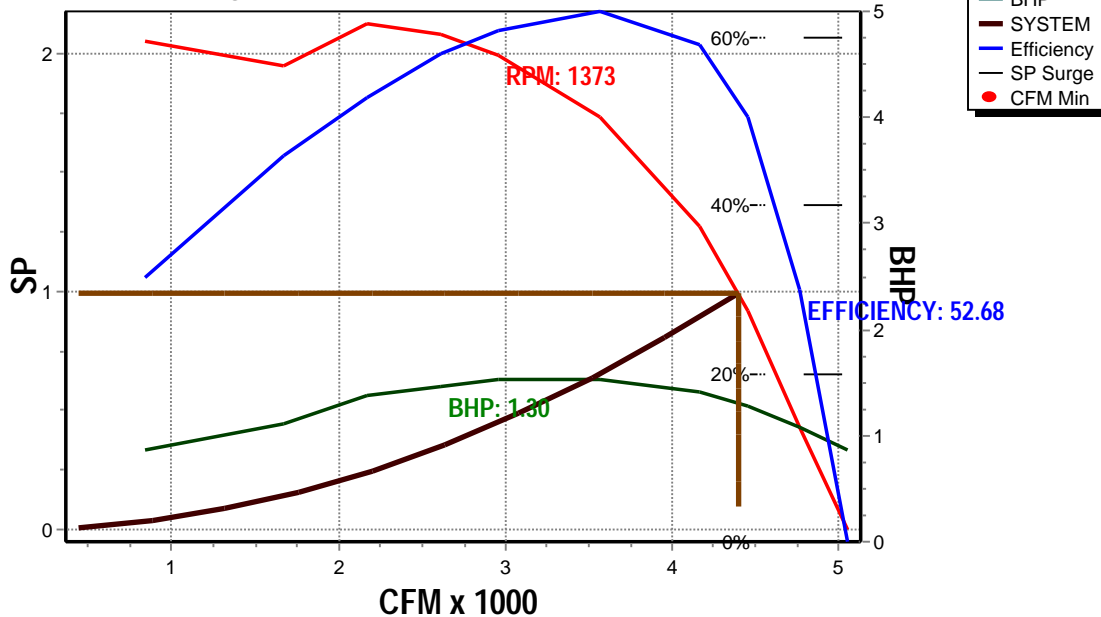



22.0" STAR Plenum

2425 South Yukon Ave - Tulsa, Oklahoma 74107-2728 - Ph. (918) 583-2266 Fax (918) 583-6094
AAONEcat32 Ver. 4.324 (SN: 6114768-C4GU4Q4U)

JOB INFORMATION:

Job Name: CEPEO Kanata
 Job Tag: RTU-8 Second Floor Zone 2
 Rep Firm:
 Date: 07-07-2022

WHEEL SPECIFICATION:

Max RPM: 2,200
 Diameter x Qty: 22.0 in. x 1
 CFM: 6800
 Tip Speed: 8,478 FPM
 Inertia: 5 WR²

OPERATING CONDITIONS:

Air Flow: 6,800 CFM
 Static Pressure: 0.67 in. Wg.
 Relief Dampers DP: 0.51 in. Wg.
 TSP: 1.18 in. Wg.
 Site Altitude: 0.00 Ft
 TSP @ Sea Level: 1.18 in. Wg.

MOTOR SELECTION:

Rated HP / Bypass: 5 / No
 Frame Size: 184T
 Nominal RPM: 1760
 VAC/PH/HZ: 575/3/60
 Efficiency: Premium / 0.895
 Enclosure Type: ODP
 Max Inertial Load: 52 WR²

FAN PERFORMANCE:

RPM: 1472
 BHP: 3.98
 Efficiency: 31.7%
 In/Out Velocity: 2080/2290 FPM
 Plenum Out Velocity: 113 FPM

FAN SOUND POWER (Inlet/Outlet):

Octave Band:	(Re 10 ⁻¹² watts)							
	1	2	3	4	5	6	7	8
	91	89	92	88	80	80	75	67
	91	89	92	88	80	80	75	67

SOUND POWER A-Weighted: 92 / 92 dB

Exhaust Fan Model: RM220A @ 1472 RPM and 100% Width
 Design Conditions: 6800 CFM @ 1.18" SP

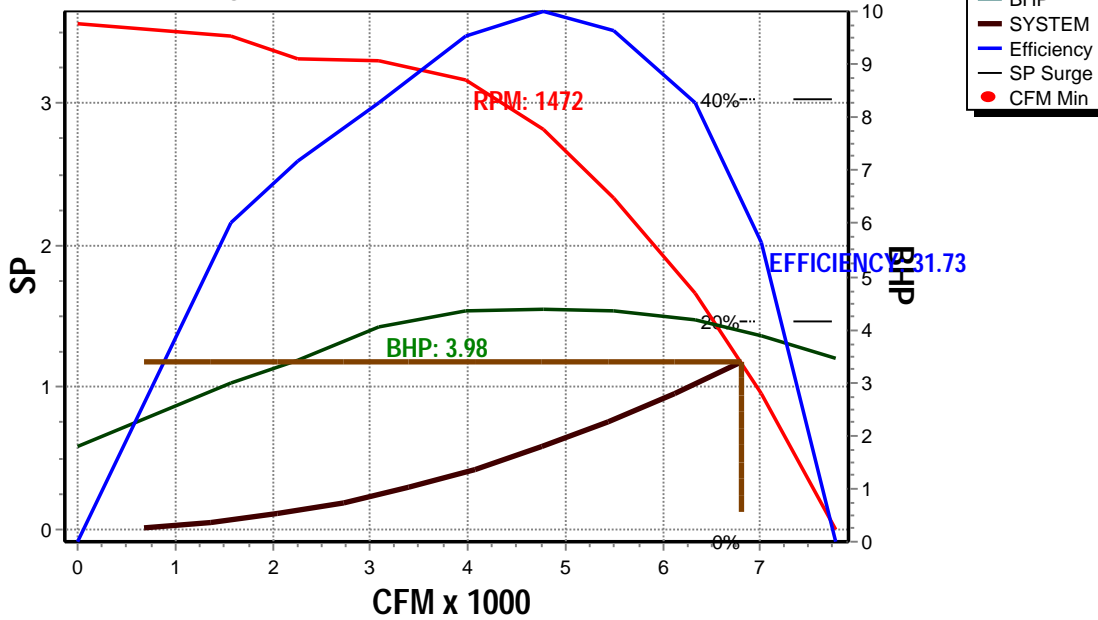



Product Data

09DE,DK Air-Cooled Condensers

15 to 90 Nominal Tons

09DK054-094
(074-094 Shown)

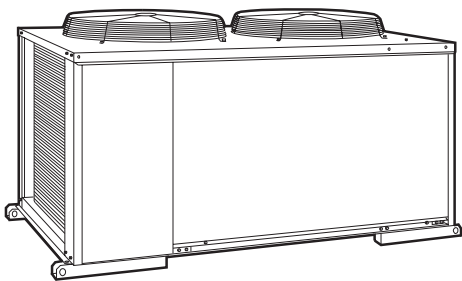
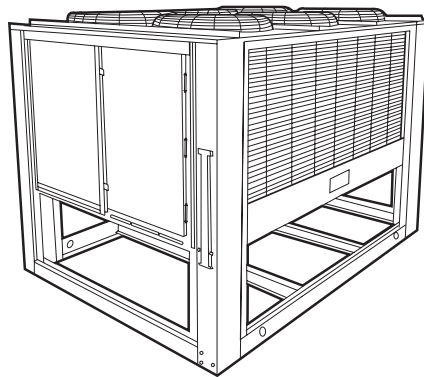

09DE016

09DK020-044
(034, 044 Shown)

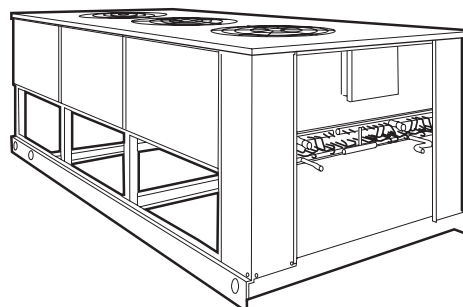

Air-Cooled Condenser Units for Remote System Application

- 11 popular sizes
- performance proven in every building application
- efficient direct-drive fans
- unit casings meet the ASTM B117 500-hour salt spray test requirements
- small footprints allow for installations in tight spaces

Features/Benefits

A family of ruggedly built condensers ideal for clinics, motels, schools, apartments, office buildings, and factories.

Greater system economy

Subcooling offers more cooling capacity. A specially designed liquid refrigerant circuit provides subcooling for increased capacity without additional power consumption. Subcooling liquid refrigerant also expands condenser applications by permitting condenser installation below the evaporator without subjecting the refrigerant to flashing before the expansion valve.

All units are UL (Underwriters' Laboratories) and UL, Canada approved.

Quieter, more efficient operation

Improved fan design — direct drive fans move air efficiently, yet quietly, at low power input. Bell-mouthed fan openings offer increased airflow, improved fan efficiency, and quiet operation.



Multi-circuit, multi-refrigerant capability

Choose the multi-circuit 09DE or 09DK and realize separate cooling system economy on each circuit. Save space and satisfy installation needs without the expense of smaller condensers with single circuitry. Models can be used with Refrigerants 12, 22, 500, 502 or 134a to meet individual system capacity requirements. A different refrigerant can be used with each cooling circuit.

Individual unit qualities

09DE016 condenser with 15-ton capacity uses a wraparound coil design (with integral subcooling) that may be used as single system or split into 2 systems. Unit with vertical air discharge contains a control box, 2 direct-drive fans, motors, and motor mounts. The U-shaped coil has a large face area to maximize heat transfer.

09DK020-044 condensers are available in 17.5-, 20-, 25-, 30-, 40-ton sizes. Models 09DK020, 024, and 028 have 2 direct drive fans, 2 motors and motor mounts. Models 09DK034 and 044 have 3 direct drive fans, 3 motors and motor mounts. Fan motors are 3-phase, TEAO (Totally Enclosed, Air Over). All units are equipped with a junction box and 2 condenser coils with integral subcooling circuits. Each circuit may be used as a separate condenser for a single system.

09DK054-094 condensers are available in 50-, 60-, 70-, 80-, and 90-ton sizes. Models 09DK054 and 064 have 4 direct-drive fans, 4 motors and motor mounts. Models 09DK074-094 have 6 direct-drive fans, 6 motors and motor mounts. All fan motors are 3-phase and are protected against single phasing conditions. Fans 1 and 2 use open drip-proof motors that are compatible with the Motormaster® V accessory. On 208-230/460 volt units, the remaining fan motors are totally enclosed. All 380/415 v and 575 v units have open drip-proof fan motors. All fan motors have permanently lubricated sealed bearings. Fans 3 and 4 on 09DK054 and 064 and fans 3, 4, 5, and 6 on 09DK074-094 models are controlled separately for efficient unit control.

These units are equipped with a hinged access door, which allows for easy entrance into the control box. Four condenser coils with integral subcooling circuits are available to create a variety of capacity split combinations. A tubing package is supplied with the unit for 100%, 50/50%, and 67/33% (09DK044-084 only) coil circuiting applications to facilitate field installations and maximize unit flexibility.

Coil split versatility

Model 09DE and 09DK coils can be split into 2 or more condensing circuits. Each circuit may handle a separate cooling system, using a different refrigerant if desired. Each circuit has a refrigerant subcooling circuit. Depending on condenser size, one to 6 condenser coil circuiting applications can be used as shown below. This saves space and provides installation flexibility.

CONDENSER		CIRCUIT NUMBER		
		1	2	3
		Percent Condenser Capacity		
09DE	016	100	—	—
		50	50	—
09DK	020,024	100	—	—
		50	50	—
		67	33	—
09DK	028,034	100	—	—
		50	50	—
		40	40	20
		60	40	—

CONDENSER		CIRCUIT NUMBER			
		1	2	3	4
		Percent Condenser Capacity			
09DK	044	100	—	—	—
		73	27	—	—
		67	33	—	—
		60	40	—	—
		53	47	—	—
		40	34	13	13
	054, 064, 074, 084	100	—	—	—
		50	50	—	—
		67	33	—	—
		33	33	33	—
094	100	—	—	—	
	50	50	—	—	

- Factory-supplied circuiting.
- Circuiting by field piping modifications.

NOTE: Split percentages shown are approximate. Actual split capacities may vary slightly from those shown.

Table of contents



Features/Benefits	Page
Model Number Nomenclature	1,2
Physical Data	3
Options and Accessories	4-9
Base Unit Dimensions	10,11
Selection Procedure	12-19
Performance Data	20
Electrical Data	21
Typical Wiring Schematic	22
Typical Piping	23-25
Application Data	26
Guide Specifications	27-30
	31-34

Model number nomenclature

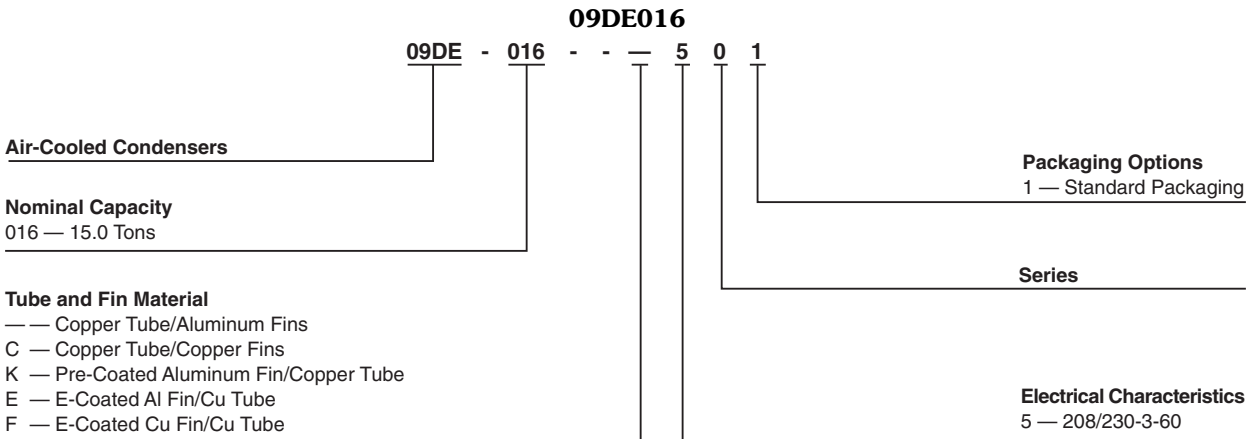

LEGEND
Al — Aluminum
Cu — Copper

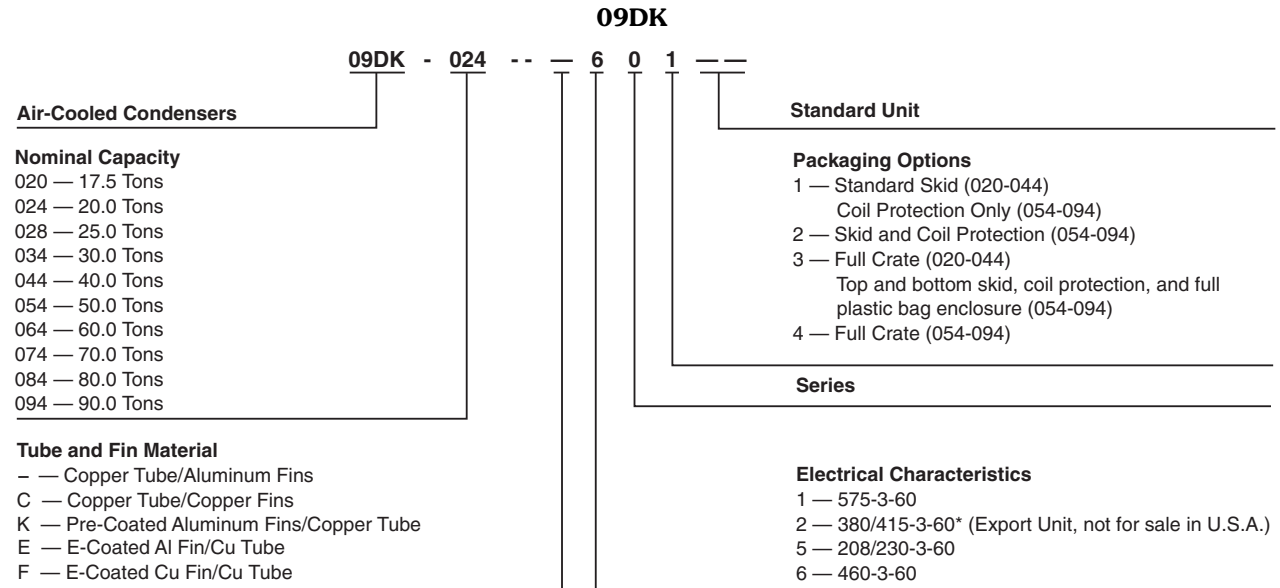

LEGEND
Al — Aluminum
Cu — Copper

*380/415-3-60 for unit sizes 054-094 only. Unit sizes 020-044 are 380-3-60.

Quality Assurance



Certificate No FM 21837

Approvals:
 ISO 9001
 EN 9000:2000

Physical data



CONDENSER	09DE		09DK			
	016	020	024	028	034	044
RATING (Tons)*	18.4	21.9	25.9	33.3	48.0	56.2
NET WEIGHT (lb)†	465	762	762	944	1438	1589
FAN						
Quantity	2	2	2	2	3	3
Prop. Diam (in.)	24	30	30	30	30	30
Rpm	1075	1140	1140	1140	1140	1140
Total Airflow (cfm)	9600	10,600	13,500	15,700	21,100	23,700
Motor Hp (per fan)	1/2	3/4	3/4	1	1	1
COILS						
Arrangement	Vertical			Horizontal		
Rows...Fins/in.	3...15.6	3...17	3...17	2...19	2...17	3...17
Total Face Area (sq ft)	29.2	23.5	23.5	39.2	58.4	58.4

CONDENSER	09DK				
	054	064	074	084	094
RATING (Tons)*	65.8	78.6	95.4	103.5	116.3
NET WEIGHT (lb)†	1645	1771	2106	2310	2714
FAN					
Quantity	4	4	6	6	6
Prop. Diam (in.)	30	30	30	30	30
Rpm	1140	1140	1140	1140	1140
Total Airflow (cfm)	35,000	35,000	52,000	51,000	57,000
Motor Hp (per fan)	1	1	1	1	1
COILS					
Arrangement			Vertical/Horizontal		
Rows...Fins/in.	2...17	3...17	2...17	3...17	3...17
Total Face Area (sq ft)	80.5	80.5	116.7	116.7	128.3

*Nominal heat rejection based on optimum refrigerant charge of R-22 with 15 F subcooling at 30 F temperature difference.

†Without refrigerant. Weights include copper tubes/aluminum fins.

ESTIMATED RADIATED SOUND POWER LEVEL, dB

UNIT	OCTAVE BAND CENTER FREQUENCY, Hz								
	63	125	250	500	1000	2000	4000	8000	dBa
09DE016	NA	89	86	84	82	76	71	64	86.3
09DK020	92	89	89	88	87	82	78	71	90.1
09DK024	94	91	91	90	88	83	81	74	92.5
09DK028	91	91	90	88	86	82	79	74	90.8
09DK034	92	92	90	88	87	83	80	75	91.5
09DK044	93	93	91	89	88	83	81	76	92.3
09DK054	101	90	94	92	90	88	85	78	95.5
09DK064	101	90	94	92	90	88	85	78	95.5
09DK074	102	96	98	97	93	91	87	80	98.8
09DK084	102	96	98	97	93	91	87	80	98.8
09DK094	102	96	98	97	93	91	87	80	98.8

NOTE: Estimated sound power levels, dB re 1 Picowatt.

ESTIMATED RADIATED SOUND POWER LEVEL, dB — 09DK054-094 CONDENSERS WITH ACCESSORY SOUND POWER REDUCTION KIT

UNIT	OCTAVE BAND CENTER FREQUENCY, Hz								
	63	125	250	500	1000	2000	4000	8000	dBa
09DK054	96	89	90	89	87	84	80	73	91.7
09DK064	96	89	90	89	87	94	80	73	91.7
09DK074	101	96	94	94	90	87	82	73	95.6
09DK084	101	96	94	94	90	87	82	73	95.6
09DK094	101	96	94	94	90	87	82	73	95.6

NOTE: Estimated sound power levels, dB re 1 Picowatt.

09DE AND 09DK020-034 COIL CONNECTIONS

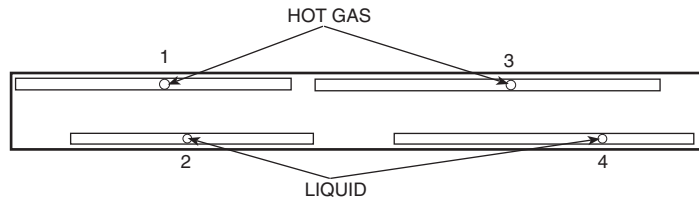
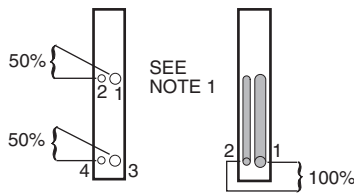

09DE 50% AND 100% SPLIT

CONDENSER 09DE	COIL CONNECTION		
	Type	No.	Size (in.)
016 50% SPLIT	Hot Gas	1, 3	7/8 ODF
	Liquid	2, 4	5/8 ODF
016 100% SPLIT	Hot Gas	1	1 1/8 ODF
	Liquid	2	5/8 ODF

09DK 50/50% COIL SPLIT

CONDENSER 09DK	COIL CONNECTION		
	Type	No.	Size (in.)
020,024, 028,034	Hot Gas	1, 3	1 1/8 ID
	Liquid	2, 4	5/8 ID

09DK 67/33% COIL SPLIT

CONDENSER 09DK	COIL CONNECTION		
	Type	No.	Size (in.)
020,024	Hot Gas	1	1 1/8 ODM
		3	1 1/8 ODF*
	Liquid	2	1/2 ODF
		4	7/8 ODF

NOTES:

1. Shaded manifolds may be field removed for 50/50 split.
2. All 50/50 splits may be field manifolded into a single 100% circuit.
3. Units may be manifolded to obtain desired coil circuiting.
4. Other circuiting arrangements are available for 09DK units. See the applicable Installation and Service Instructions for details.

*Street elbow is factory supplied, field installed.

09DK044 COIL CONNECTIONS

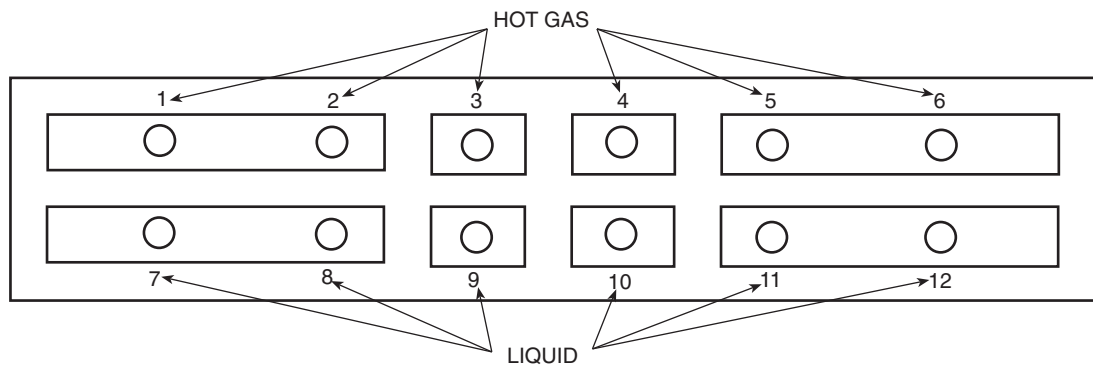

PERCENT CAPACITY SPLIT	LINE TYPE	CONNECTION NUMBER	COIL CONNECTION in.-ODM
100	Hot Gas	1,6/2,3,4,5	1 3/8/1 1/8
	Liquid	7,12/8,9,10,11	7/8/5/8
74/26	Hot Gas	1,6/3,4	1 3/8/1 1/8
	Liquid	7,12/9,10	7/8/5/8
60/40	Hot Gas	1/6/3,4,5	1 3/8/1 3/8/1 1/8
	Liquid	7/12/9,10,11	7/8/7/8/5/8
53/47	Hot Gas	1/6/2,3,4,5	1 3/8/1 3/8
	Liquid	7/12/8,9,10,11	7/8/7/8/5/8/5/8
66/34	Hot Gas	1/6/2,3,4	1 3/8/1 3/8/1 1/8
	Liquid	7,12/8,9,10	7/8/7/8/5/8
40/13/13/34	Hot Gas	1/3/4/6	1 3/8/1 1/8/1 1/8/1 1/8
	Liquid	7/9/10/12	7/8/5/8/5/8/7/8

09DK054-084 COIL CONNECTIONS

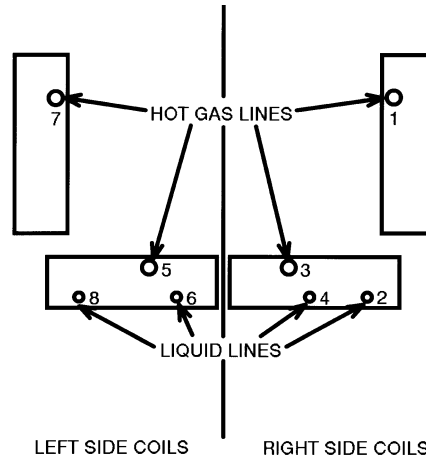

09DK054,064

PERCENT CAPACITY SPLIT	LINE TYPE	CONNECTION NUMBER	COIL CONNECTION* in.-ODM	TUBING CONNECTION in.-ODM†	
100	Hot Gas	1,3,5,7	1 ¹ / ₈	1 ⁵ / ₈	
	Liquid	2,4,6,8	7 ⁷ / ₈	1 ⁷ / ₈	
50/50	Hot Gas	1,3,5,7	1 ¹ / ₈	1 ³ / ₈	1 ³ / ₈
	Liquid	2,4,6,8	7 ⁷ / ₈	7 ⁷ / ₈	7 ⁷ / ₈
66/34	Hot Gas	1,3,5,7	1 ¹ / ₈	1 ³ / ₈	1 ¹ / ₈
	Liquid	2,4,6,8	7 ⁷ / ₈	7 ⁷ / ₈	7 ⁷ / ₈
34/34/32	Hot Gas	1/7/3,5	1 ¹ / ₈	—	
	Liquid	2/8/4,6	7 ⁷ / ₈	—	
34/34/16/16	Hot Gas	1/7/3/5	1 ¹ / ₈	—	
	Liquid	2/8/4/6	7 ⁷ / ₈	—	

*Connection sizes reflect size of each coil header nozzle.

†A tubing package is factory supplied to facilitate field piping installation for the 100%, 50/50%, and 67/33% capacity split applications. See installation instructions for more information.

09DK074

PERCENT CAPACITY SPLIT	LINE TYPE	CONNECTION NUMBER	COIL CONNECTION* in.-ODM	TUBING CONNECTION in.-ODM†	
100	Hot Gas	1,3,5,7	1 ³ / ₈	2 ¹ / ₈	
	Liquid	2,4,6,8	7 ⁷ / ₈	1 ¹ / ₈	
50/50	Hot Gas	1,3,5,7	1 ³ / ₈	1 ⁵ / ₈	1 ⁵ / ₈
	Liquid	2,4,6,8	7 ⁷ / ₈	7 ⁷ / ₈	7 ⁷ / ₈
68/32	Hot Gas	1,3,5,7	1 ³ / ₈	1 ⁵ / ₈	1 ³ / ₈
	Liquid	2,4,6,8	7 ⁷ / ₈	1 ¹ / ₈	7 ⁷ / ₈
32/32/36	Hot Gas	1/7/3,5	1 ³ / ₈	—	
	Liquid	2/8/4,6	7 ⁷ / ₈	—	
32/32/18/18	Hot Gas	1/7/3/5	1 ³ / ₈	—	
	Liquid	2/8/4/6	7 ⁷ / ₈	—	

*Connection sizes reflect size of each coil header nozzle.

†A tubing package is factory supplied to facilitate field piping installation for the 100%, 50/50%, and 67/33% capacity split applications. See installation instructions for more information.

09DK084

PERCENT CAPACITY SPLIT	LINE TYPE	CONNECTION NUMBER	COIL CONNECTION* in.-ODM	TUBING CONNECTION in.-ODM†	
100	Hot Gas	1,3,5,7	1 ³ / ₈	2 ¹ / ₈	
	Liquid	2,4,6,8	7 ⁷ / ₈	1 ¹ / ₈	
50/50	Hot Gas	1,3,5,7	1 ³ / ₈	1 ⁵ / ₈	1 ⁵ / ₈
	Liquid	2,4,6,8	7 ⁷ / ₈	7 ⁷ / ₈	7 ⁷ / ₈
67/33	Hot Gas	1,3,5,7	1 ³ / ₈	1 ⁵ / ₈	1 ³ / ₈
	Liquid	2,4,6,8	7 ⁷ / ₈	1 ¹ / ₈	7 ⁷ / ₈
33/33/33	Hot Gas	1/7/3,5	1 ³ / ₈	—	
	Liquid	2/8/4,6	7 ⁷ / ₈	—	
33/33/17/17	Hot Gas	1/7/3/5	1 ³ / ₈	—	
	Liquid	2/8/4/6	7 ⁷ / ₈	—	

*Connection sizes reflect size of each coil header nozzle.

†A tubing package is factory supplied to facilitate field piping installation for the 100%, 50/50%, and 67/33% capacity split applications. See installation instructions for more information.

09DK094 COIL CONNECTIONS

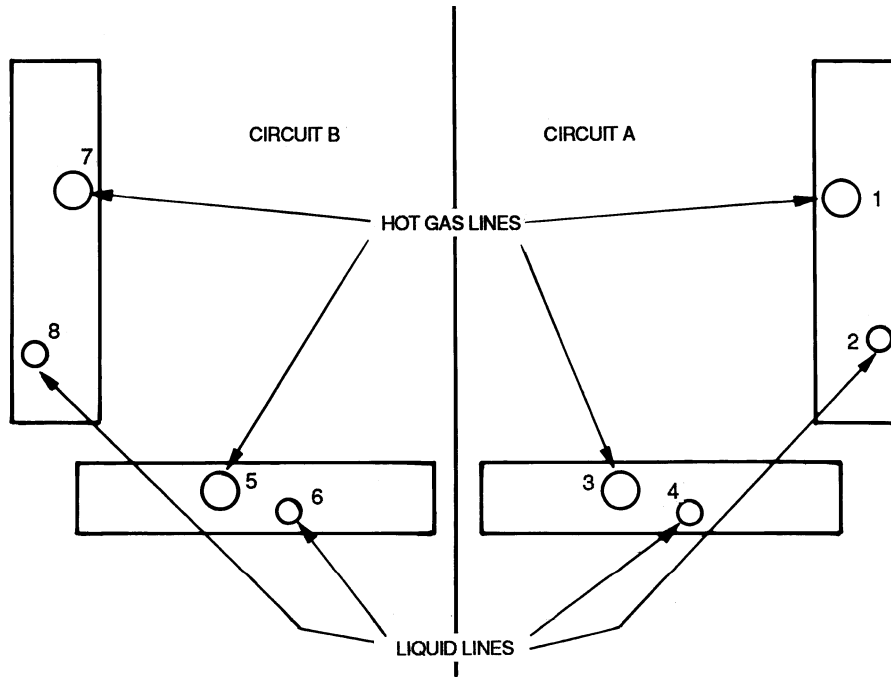

PERCENT CAPACITY SPLIT	LINE TYPE	COIL CONNECTION NUMBER	COIL CONNECTION in.-ODM*	TUBING CONNECTION in.-ODM†
100	Hot Gas	1,3,5,7	1 ³ / ₈	2 ¹ / ₈
	Liquid	2,4,6,8	7/ ₈	1 ¹ / ₈
50/50	Hot Gas	1,3/5,7	1 ³ / ₈	1 ⁵ / ₈ /1 ⁵ / ₈
	Liquid	2,4/6,8	7/ ₈	7/ ₈ /7/ ₈

*Connection sizes reflect size of each coil header nozzle.
 †A tubing package is factory supplied to facilitate field piping installation for the 100% capacity split applications. See installation instructions for more information.

Physical data (cont)



WEIGHT DISTRIBUTION (Lb)

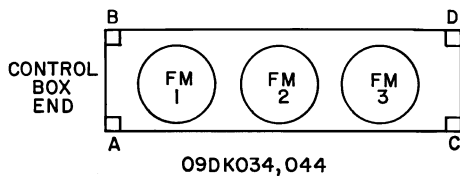
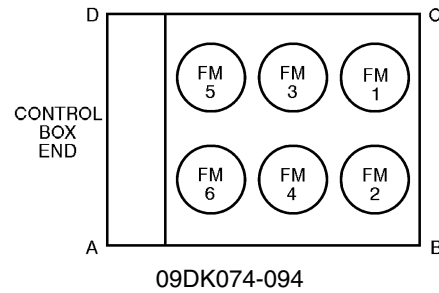
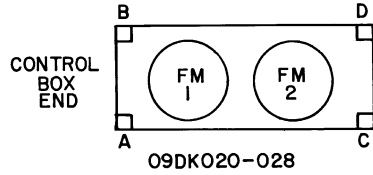
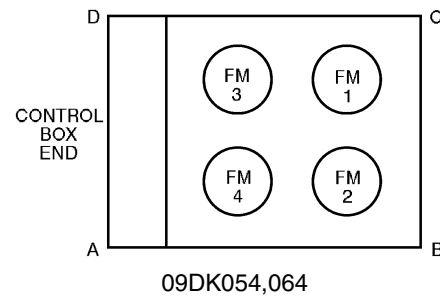
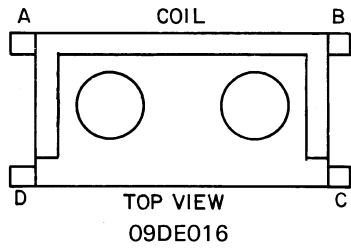

UNIT	COIL TYPE	TOTAL WEIGHT (lb)	OPERATING CORNER WEIGHTS			
			A	B	C	D
09DE						
016	Cu/Al	465	122	120	111	112
	Cu/Cu	605	159	156	144	146
09DK						
020, 024	Cu/Al	797	186	186	212	212
	Cu/Cu	921	215	215	245	245
028	Cu/Al	983	299	229	262	262
	Cu/Cu	1137	268	268	300	300
034	Cu/Al	1495	349	349	399	399
	Cu/Cu	1700	396	396	454	454
044	Cu/Al	1676	391	391	447	447
	Cu/Cu	1984	462	462	529	529

UNIT 09DK	COIL TYPE	TOTAL WEIGHT (lb)	OPERATING CORNER WEIGHTS			
			A	B	C	D
054	Cu/Al	1695	452	425	396	422
	Cu/Cu	1983	524	497	468	494
064	Cu/Al	1845	489	462	434	459
	Cu/Cu	2278	598	571	542	568
074	Cu/Al	2200	618	526	486	571
	Cu/Cu	2617	722	630	589	675
084	Cu/Al	2421	673	581	541	626
	Cu/Cu	3099	843	751	709	796
094	Cu/Al	2850	769	676	658	747
	Cu/Cu	3560	960	845	821	934

LEGEND

Al — Aluminum
Cu — Copper
FM — Fan Motor



REFRIGERANT CIRCUIT DATA

CONDENSER	09DE		09DK											
	016		020,024				028				034			
COIL														
No. of Circuits*	2	2	1	1	2	1	1	2	1	2	1	1	2	1
Cap. (%/ckt)	50	50	67	33	50	60	40	40	20	50	60	40	40	20
REFRIGERANT														
Min Chg (lb/ckt)	4.75	10.59	14.12	7.06	11.77	14.12	9.41	9.41	4.71	17.53	21.04	14.03	14.03	7.01
Opt Chg (lb/ckt)	6.00	12.46	16.61	8.31	13.84	16.61	11.08	11.08	5.54	20.63	24.76	16.50	16.50	8.25
Vol (cu ft/ckt)	0.39	0.30	0.40	0.20	0.33	0.40	0.26	0.26	0.14	0.49	0.59	0.39	0.39	0.20
STORAGE CAP.														
(lb/ckt)†														
R-12	24.3	19.2	25.7	12.7	21.1	25.3	16.9	16.9	8.4	31.3	37.6	25.0	25.0	12.5
R-22	22.1	17.5	23.3	11.7	19.3	23.2	15.4	15.4	7.7	28.7	34.4	23.0	23.0	11.5
R-500	21.4	16.5	22.1	10.9	18.2	21.8	14.5	14.5	7.3	26.9	32.3	21.5	21.5	10.8
R-502	22.5	18.3	24.5	12.1	20.2	24.2	16.1	16.1	8.1	29.9	35.9	23.9	23.9	12.0
R-134a	24.3	19.2	25.7	12.7	21.1	25.3	16.9	16.9	8.4	31.3	37.6	25.0	25.0	12.5

CONDENSER	09DK										
	044										
COIL											
No. of Circuits*	1	1	2	1	1	1	1	1	1	1	
Cap. (%/ckt)	40	34	13	73	27	67	33	60	40	53	47
REFRIGERANT											
Min Chg (lb/ckt)	21.04	17.36	6.84	38.40	14.20	35.07	17.53	31.56	21.04	27.88	24.72
Opt Chg (lb/ckt)	24.75	20.62	8.25	45.17	16.71	41.25	20.62	37.13	24.75	32.80	29.08
Vol (cu ft/ckt)	0.60	0.52	0.19	1.09	0.40	1.0	0.49	0.89	0.60	0.79	0.70
STORAGE CAP.											
(lb/ckt)†											
R-12	38.1	32.4	12.4	69.6	25.7	64.0	31.3	57.2	38.1	50.5	44.8
R-22	34.8	29.6	11.3	63.6	23.5	58.1	29.0	52.3	34.8	46.2	40.9
R-500	32.8	27.8	10.6	59.8	22.1	54.6	27.3	49.1	32.8	43.4	38.4
R-502	36.4	31.0	11.8	66.5	24.6	51.0	30.1	54.7	36.4	48.3	42.8
R-134a	38.1	32.4	12.4	69.6	25.7	64.0	31.3	57.2	38.1	50.5	44.8

CONDENSER	09DK							
	054				064			
COIL								
No. of Circuits*	2	1	1	2	2	1	2	2
Cap. (%/ckt)	50	66	34	16	50	66	34	16
REFRIGERANT								
Min Chg (lb/ckt)	24.0	32.0	16.0	8.0	36.0	48.0	25.0	11.0
Opt Chg (lb/ckt)	28.0	37.0	19.0	9.0	43.0	56.0	29.0	13.0
Vol (cu ft/ckt)	0.68	0.89	0.46	0.21	1.01	1.32	0.69	0.32
STORAGE CAP.								
(lb/ckt)†								
R-12	43.0	57.0	30.0	14	64.0	85.0	44.0	20.0
R-22	40.0	52.0	27.0	12	59.0	78.0	40.0	19.0
R-500	37.0	49.0	26.0	12	55.0	73.0	38.0	17.0
R-502	41.0	55.0	28.0	13	61.0	81.0	42.0	19.0
R-134a	43.0	57.0	30.0	14	64.0	85.0	44.0	20.0

CONDENSER	09DK								
	074			084				094	
COIL									
No. of Circuits*	2	1	2	2	2	1	2	2	2
Cap. (%/ckt)	50	68	32	18	50	67	33	17	50
REFRIGERANT									
Min Chg (lb/ckt)	35.0	48.0	22.0	12.0	52.0	70.0	35.0	17.0	57.8
Opt Chg (lb/ckt)	41.0	56.0	26.0	15.0	62.0	82.0	41.0	21.0	68.0
Vol (cu ft/ckt)	0.97	1.32	0.62	0.35	1.46	1.95	0.97	0.49	1.64
STORAGE CAP.									
(lb/ckt)†									
R-12	63.0	85.0	40.0	22.0	95.0	127.0	63.0	32.0	104.7
R-22	57.0	78.0	37.0	21.0	87.0	116.0	58.0	29.0	95.7
R-500	54.0	74.0	35.0	19.0	82.0	109.0	55.0	27.0	90.0
R-502	60.0	82.0	39.0	21.0	91.0	121.0	61.0	30.0	100.1
R-134a	63.0	85.0	40.0	22.0	95.0	127.0	63.0	32.0	104.7

*See pages 4-7 for circuiting arrangements.

†Storage capacity calculated for 80% liquid and 20% vapor at 90 F.

Options and accessories



OPTION/ACCESSORY	FOR USE WITH	OPTION	ACCESSORY
EnviroShield™ Condenser Coil	09DE,09DK	X	
Motormaster® I Head Pressure Control	09DE016 09DK020-044		X
Coil Grille	09DE016		X
Fan Cycling Control	09DE016 09DK020-044		X
Fan Sound Reduction Kit	09DK054-094		X
Security Grille Package	09DK054-094		X
Control Transformer	09DK054-094		X
Condenser Coil Hail Guard	09DK054-094		X
Motormaster V Head Pressure Control	09DK054-094		X

SECURITY GRILLE (09DK054-094: 09DK074,084 SHOWN)

SIDE VIEW

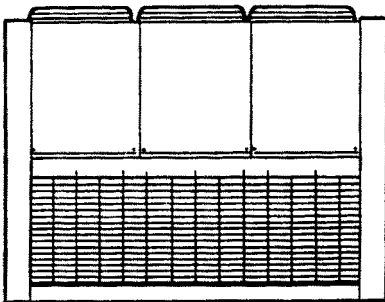

The security grilles protect the condenser coils from debris or vandalism after the unit has been installed. Upper condenser coil grilles are available to protect vertical coils. Lower end and side grilles are available to protect the area beneath the coils.

COIL GRILLE (09DE016)

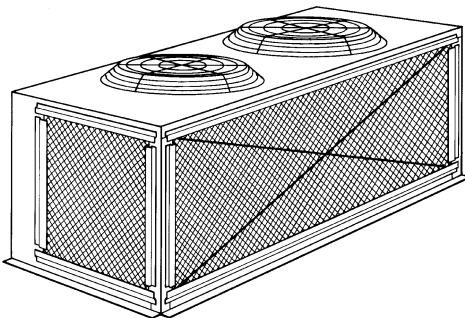

Protects coil from external damage and prevents leaves and other debris from entering fins (available for field installation on 09DE016 only).

FAN CYCLING CONTROL

During intermediate seasons, proper condensing temperature is controlled by fan control packages which permit shutoff of one or 2 condenser fans. These packages are also required when using the Motormaster head pressure control (09DE016, 09DK020-044 units).

MOTORMASTER I HEAD PRESSURE CONTROL (09DE, 09DK020-044)

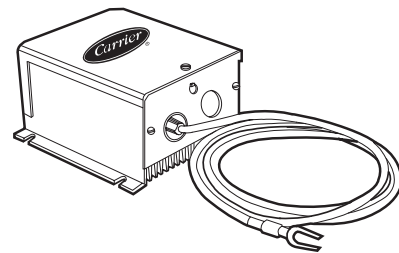

This exclusive solid-state device automatically modulates fan speed from full to zero rpm to maintain proper condensing temperature at low ambient temperature conditions to -20 F.

MOTORMASTER V HEAD PRESSURE CONTROL (09DK054-094)

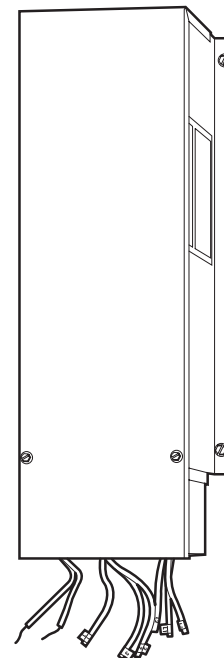

The Motormaster V head pressure control is used to permit low ambient operation down to -20 F by modulating the fan speed on each of the primary fans (1 and 2). The standard factory-installed motors are compatible with the Motormaster V control.

**FAN SOUND REDUCTION KIT
(09DK054-094)**

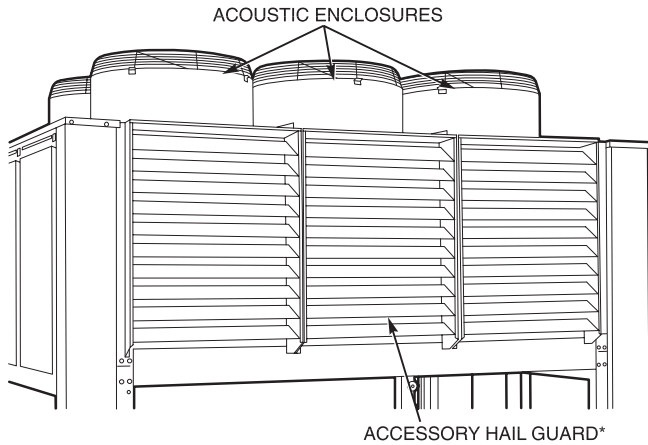

*Hail guard not required.

The fan sound reduction kit consists of a specially designed system of fans and acoustic enclosures for reducing sound levels without compromising unit performance. A fan motor change is not required and the fan system is compatible with Motormaster® V device. Two kits are required for the 09DK054,064 units and three kits are required for the 09DK074-094 units.

**CONDENSER COIL HAIL GUARD
(09DK054-094)**

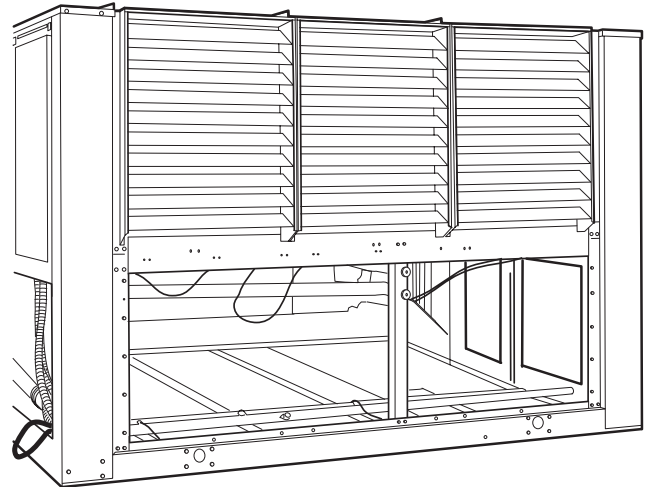

This accessory protects the coils against damage from hail and other flying debris. Two packages are required for 09DK054 and 064 and three packages required for 09DK074-094.

**CONTROL TRANSFORMER
(09DK054-094)**

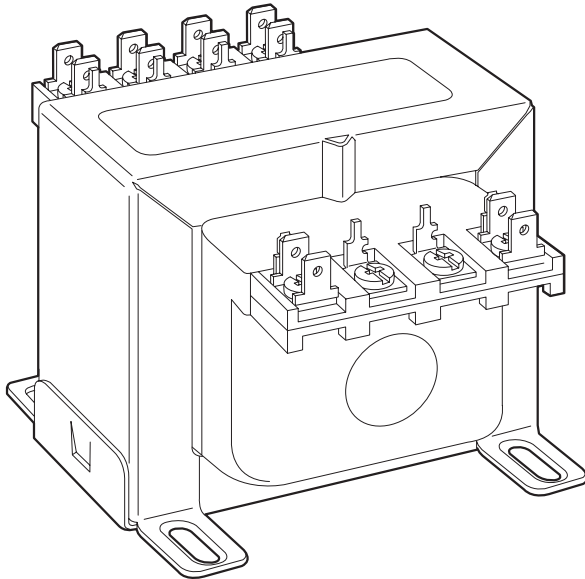

The control transformer is used to convert 200-208/230/460 v to 115 v for use on 115-v control systems, utilizing power from the main unit power connection.

Enviro-Shield™ condenser options — Several options are available to match coil protection to site conditions for optimum durability. See table below and refer to the Application Data for selection guidance. Consult your Carrier representative for further information.

CONDENSER COIL OPTIONS

COPPER-TUBE COILS WITH ENVIRO-SHIELD OPTION*	ENVIRONMENT					Combined Industrial/ Coastal
	Standard	Mild Coastal	Moderate Coastal	Severe Coastal	Industrial	
Al Fins (Standard Coils)	X					
Cu Fins			X			
Al Fins, E-Coated					X	
Cu Fins, E-Coated				X		X
Al Fins, Pre-coated		X				

LEGEND

- Al — Aluminum
- Cu — Copper
- E-Coated — Epoxy Coating Applied to Entire Coil Assembly
- Enviro-Shield — Family of Coil Protection Options
- Pre-Coated — Epoxy Coating Applied to Fin Stock Material

Base unit dimensions



09DE016

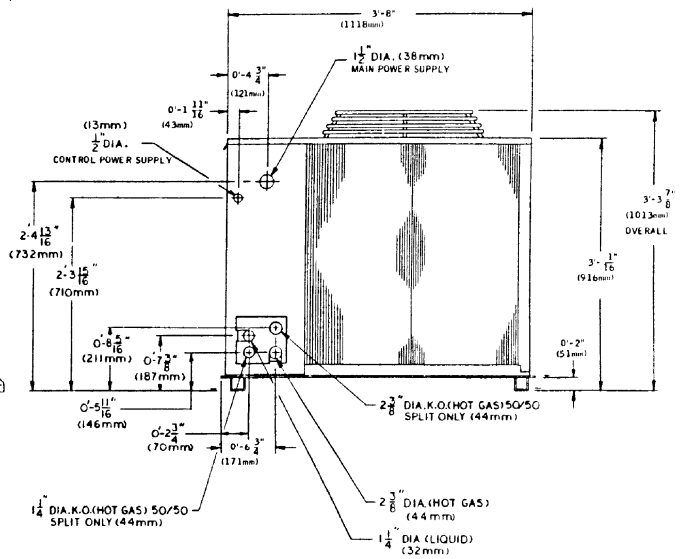
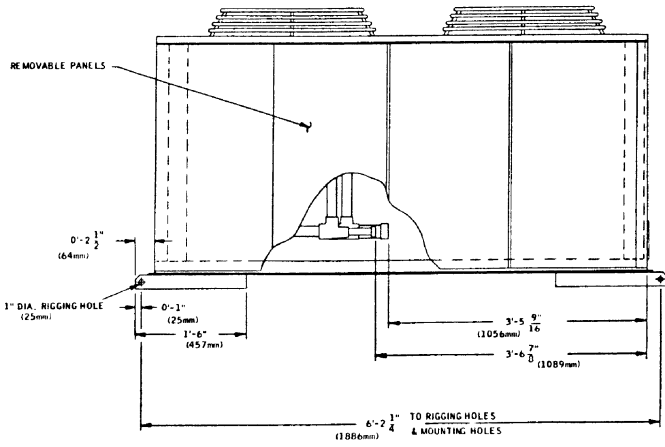
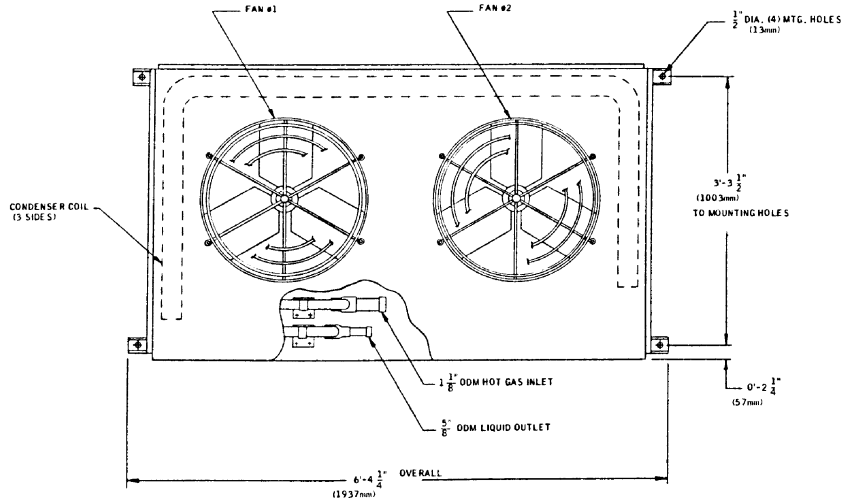

UNIT	WEIGHT
09DE016	465 lb (211 kg)

NOTE: See page 28 for service clearances.

09DK020-028

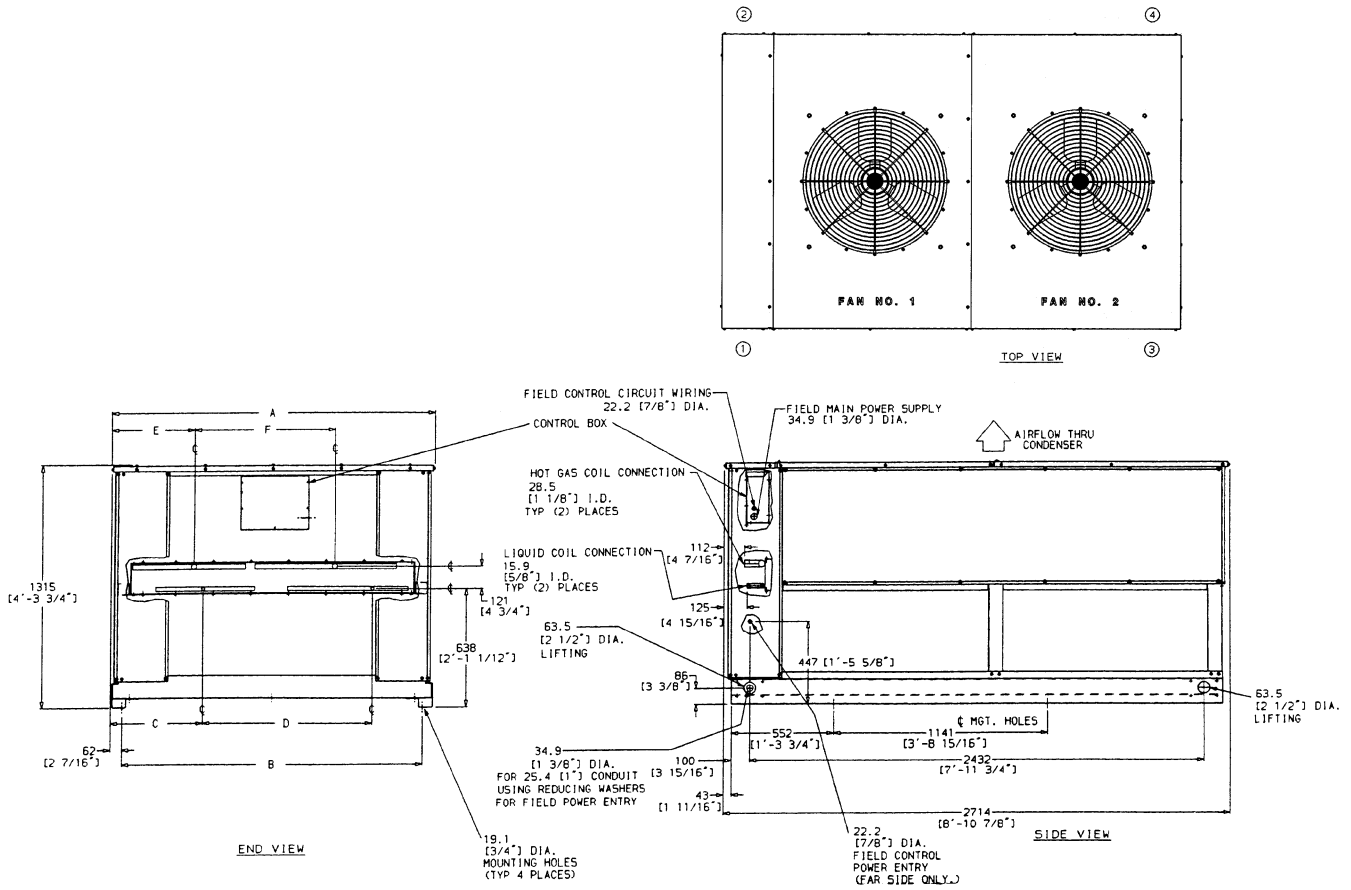

UNIT	A	B	C	D	E	F
09DK-020, 024	1131	1007	240	432	228	559
09DK-020C, 024C	[3'-8 1/2"]	[3'-3 11/16"]	[9'- 7/16"]	[1'-5"]	[0'-9"]	[1'-10"]
09DK-028	1742	1619	496	914	445	762
09DK-028C	[5'-8 5/8"]	[5'-3 3/4"]	[1'-7 9/16"]	[3'-0"]	[1'-5 1/2"]	[2'-6"]

NOTES:

1. There must be 1220 mm [4'-0"] for service and for unrestricted airflow on all sides of unit.
2. There must be minimum 2440 mm [8'-0"] clear air space above unit.
3. Dimensions are in millimeters. Dimensions in [] are in ft-in.
4. The approximate operating weight of the unit is as follows:

UNIT	TOTAL		OPERATING WT. AT SUPPORT POINTS			
			① and ②		③ and ④	
	Wt lb	Wt kg	Wt lb	Wt kg	Wt lb	Wt kg
09DK-020, 024	797	361.5	186	84.4	212	96.2
09DK-020C, 024C	921	417.8	215	97.5	245	111.1
09DK-028	983	445.9	229	103.9	262	118.8
09DK-028C	1137	515.7	268	121.6	300	136.1

5. The letter C after model size refers to copper tube/copper fin coils.

Base unit dimensions (cont)



09DK034

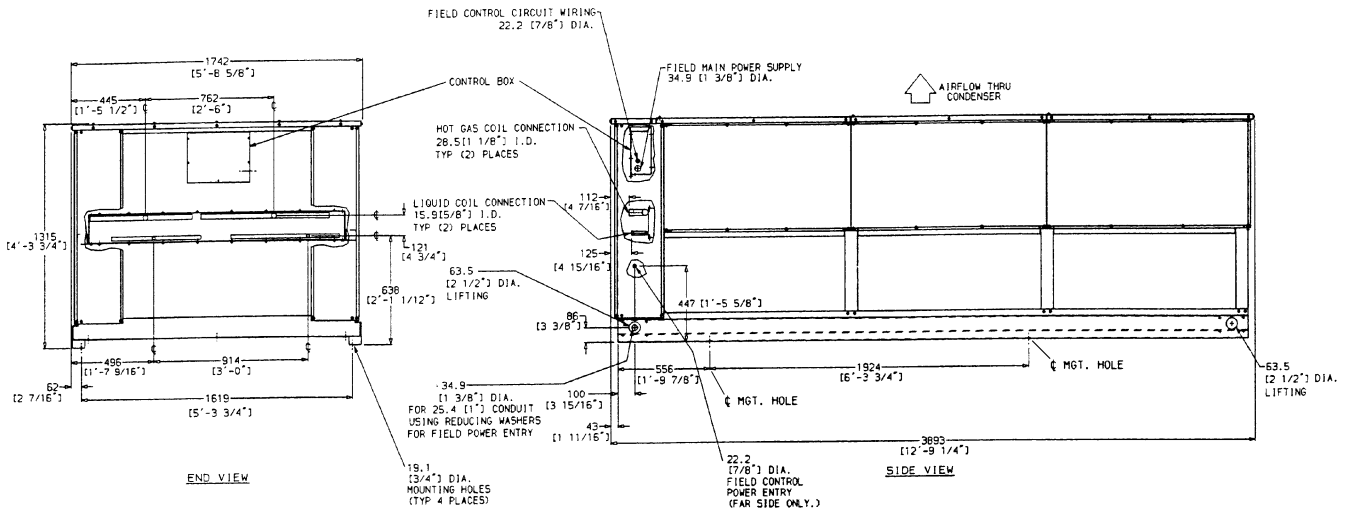
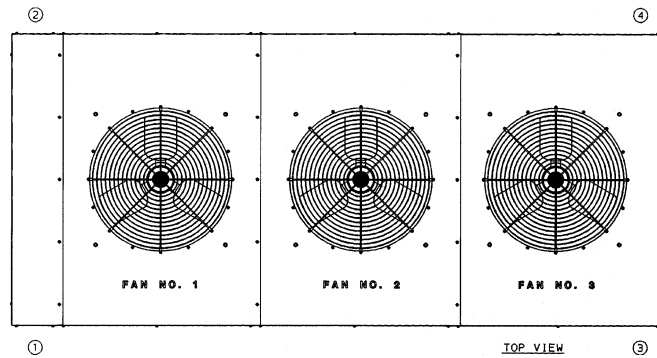

NOTES:

1. There must be 1220 mm [4'-0"] for service and for unrestricted airflow on all sides of unit.
2. There must be minimum 2440 mm [8'-0"] clear air space above unit.
3. Dimensions are in millimeters. Dimensions in [] are in ft-in.
4. The approximate operating weight of the unit is as follows:

UNIT	TOTAL		OPERATING WT. AT SUPPORT POINTS			
			① and ②		③ and ④	
	Wt lb	Wt kg	Wt lb	Wt kg	Wt lb	Wt kg
09DK-034	1495	678.1	349	158.3	399	181.0
09DK-034C	1700	771.1	396	179.6	454	205.9

5. The letter C after model size refers to copper tube/copper fin coils.

09DK044

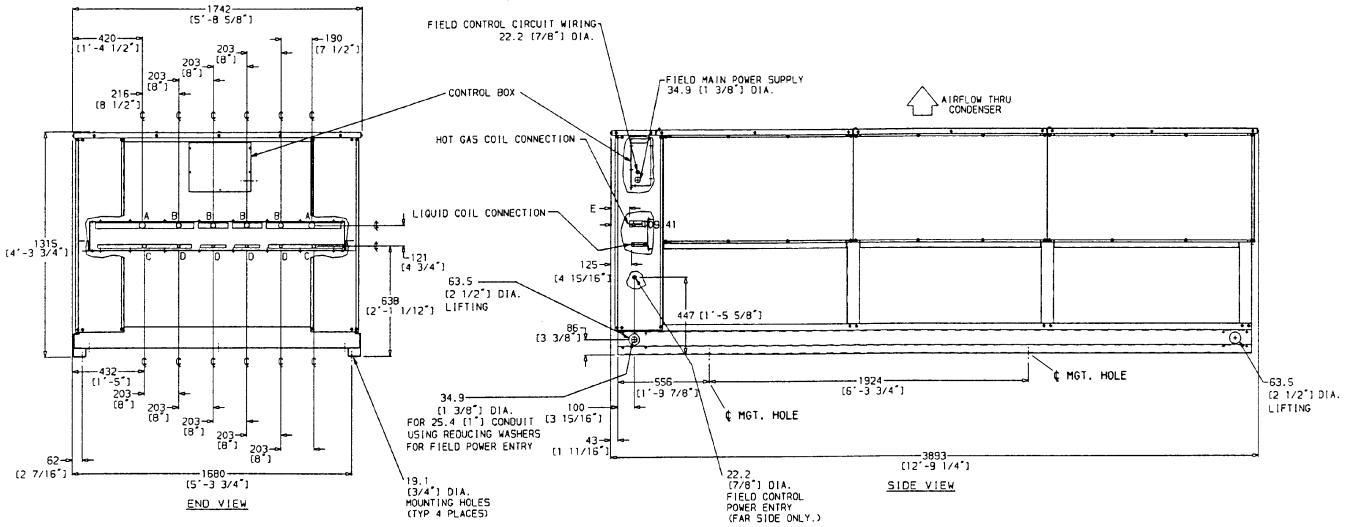
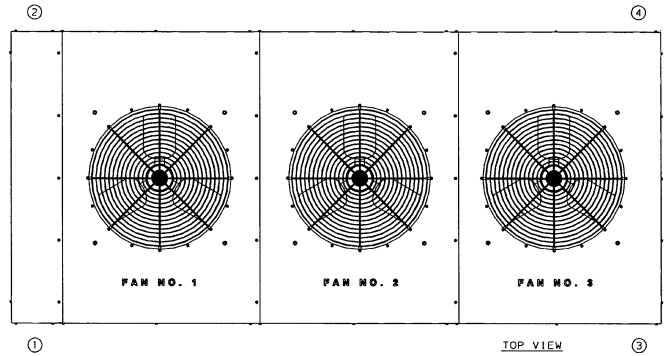

UNIT	A	B	C	D	E
09DK-044	34.9 ID [1 3/8"]	28.5 ID [1 1/8"]	22.2 ID [7/8"]	15.9 ID [5/8"]	See Note 4
09DK-044C					

NOTES:

1. There must be 1220 mm [4'-0"] for service and for unrestricted airflow on all sides of unit.
2. There must be minimum 2440 mm [8'-0"] clear air space above unit.
3. Dimensions are in millimeters. Dimensions in [] are in ft-in.
4. Dimension "E" for 34.9 mm ID is 118 mm [4 5/8"].
Dimension "E" for 28.5 mm ID is 112 mm [4 7/8"].
5. The approximate operating weight of the unit is as follows:

UNIT	TOTAL		OPERATING WT. AT SUPPORT POINTS			
			① and ②		③ and ④	
	Wt lb	Wt kg	Wt lb	Wt kg	Wt lb	Wt kg
09DK-044	1676	760.2	391	177.4	447	202.8
09DK-044C	1984	900.0	462	209.6	529	240.0

6. The letter C after model size refers to copper tube/copper fin coils.

Base unit dimensions (cont)



09DK054,064 (SEE PAGE 19 FOR POWER WIRING ACCESS HOLES)

NOTES:

- The approximate operating weight of the unit is:
 09DK-054 — 1695 lb [769 kg]
 09DK-054C — 1983 lb [900 kg]
 09DK-064 — 1845 lb [837 kg]
 09DK-064C — 2278 lb [1033 kg]
- Unit must have clearances for airflow as follows:
 Top — Do not restrict in any way
 Ends — 5 ft [1524 mm]
 Sides — 6 ft [1829 mm]
- All units are shipped with a capacity split tubing kit. This kit may be used by the field to obtain 100%, 50/50% and 66/34% capacity splits. To obtain a 34/34/32% capacity split, coils must be manifolded by the field. Coils are factory circuited for a 34/34/16/16% capacity split.
- The letter C after model size refers to copper tube/copper fin coils.

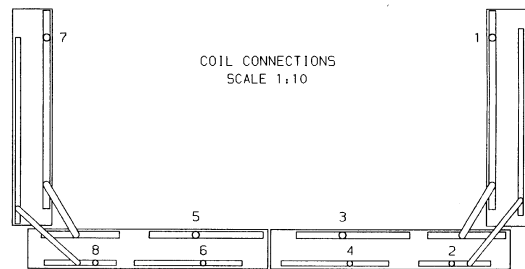

HEADER
END

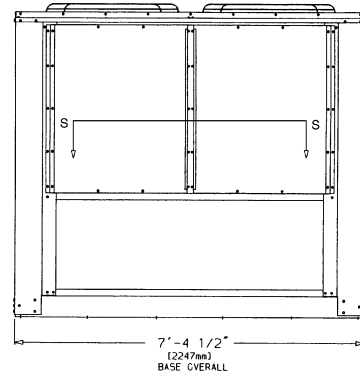

UNIT	DIMENSION Y	DIMENSION X	OPERATING CORNER WEIGHTS			
			A	B	C	D
09DK-054	3'-6 11/16" [1084 mm]	4'-1 7/8" [1222 mm]	452 lb [205 kg]	425 lb [193 kg]	396 lbs [180 kg]	422 lb [191 kg]
09DK-054C	3'-6 7/8" [1090 mm]	4'-5 1/16" [1227 mm]	524 lb [238 kg]	497 lb [225 kg]	468 lbs [212 kg]	494 lb [224 kg]
09DK-064	3'-6 3/4" [1087 mm]	4'-3 1/16" [1224 mm]	489 lb [222 kg]	462 lb [210 kg]	434 lbs [197 kg]	459 lb [208 kg]
09DK-064C	3'-7 1/8" [1095 mm]	4'-1 1/2" [1232 mm]	598 lb [271 kg]	571 lb [259 kg]	542 lbs [246 kg]	568 lb [258 kg]

CAPACITY SPLIT	CONNECTIONS			
	Type	Number		Size
100%	Hot Gas	1, 3, 5, 7		1 1/8" ID
	Liquid	2, 4, 6, 8		7/8" ID
50/50%	Hot Gas	1, 3	5, 7	1 1/8" ID
	Liquid	2, 4	6, 8	7/8" ID
66/34%	Hot Gas	1, 3, 5	7	1 1/8" ID
	Liquid	2, 4, 6	8	7/8" ID
34/34/32%	Hot Gas	1	7, 3, 5	1 1/8" ID
	Liquid	2	8, 4, 6	7/8" ID
34/34/16/16%	Hot Gas	1	7, 3, 5	1 1/8" ID
	Liquid	2	8, 4, 6	7/8" ID

CONTROL BOX
END

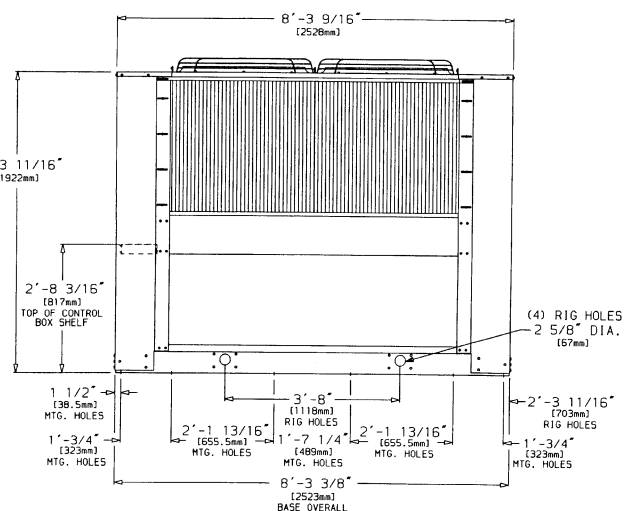
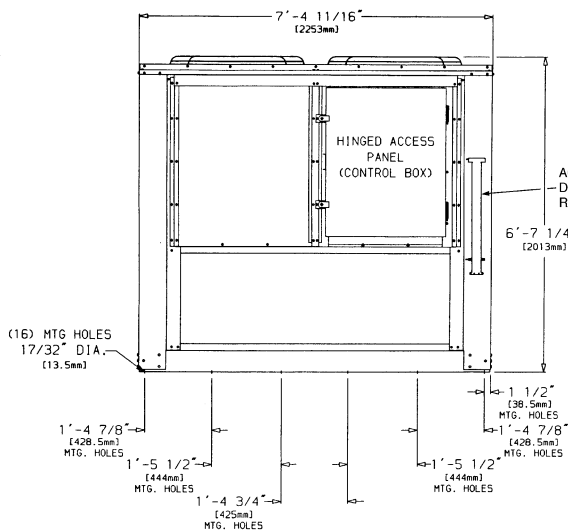
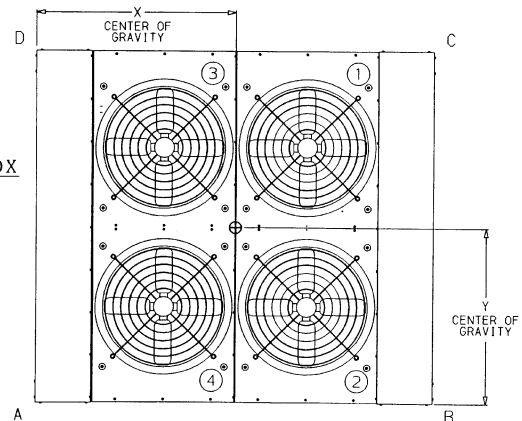

09DK074,084 (SEE PAGE 19 FOR POWER WIRING ACCESS HOLES)

NOTES:

- The approximate operating weight of the unit is:
 09DK-074 — 2200 lb [998 kg]
 09DK-074C — 2617 lb [1187 kg]
 09DK-084 — 2421 lb [1098 kg]
 09DK-084C — 3099 lb [1406 kg]
- Unit must have clearances for airflow as follows:
 Top — Do not restrict in any way
 Ends — 5 ft [1524 mm]
 Sides — 6 ft [1829 mm]
- All units are shipped with a capacity split tubing kit. This kit may be used by the field to obtain 100%, 50/50% and 66/33% capacity splits. To obtain a 33/33/33% capacity split, coils must be manifolded by the field. Coils are factory circuited for a 33/33/17/17% capacity split.
- The letter C after model size refers to copper tube/copper fin coils.

HEADER
END

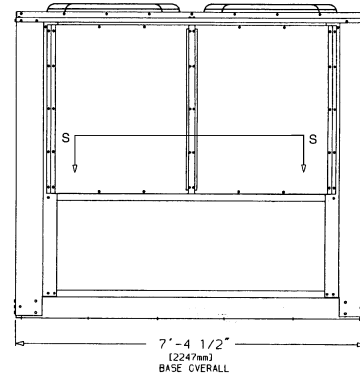
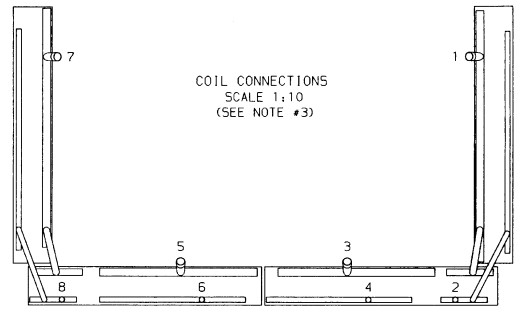

UNIT	DIMENSION Y	DIMENSION X	OPERATING CORNER WEIGHTS			
			A	B	C	D
09DK-074	3'-6 1/2" [1080 mm]	4'- 8 11/16" [1440 mm]	618 lb [280 kg]	526 lb [239 kg]	486 lbs [220 kg]	571 lb [259 kg]
09DK-074C	3'-6 13/16" [1087 mm]	4'- 9 3/8" [1458 mm]	722 lb [328 kg]	630 lb [286 kg]	589 lbs [267 kg]	675 lb [306 kg]
09DK-084	3'-6 5/8" [1082 mm]	4'- 9 1/8" [1450 mm]	673 lb [305 kg]	581 lb [264 kg]	541 lbs [245 kg]	626 lb [284 kg]
09DK-084C	3'-7" [1092 mm]	4'-10 1/8" [1476 mm]	843 lb [382 kg]	751 lb [341 kg]	709 lbs [322 kg]	796 lb [361 kg]

CAPACITY SPLIT	CONNECTIONS		
	Type	Number	Size
100%	Hot Gas	1, 3, 5, 7	1 3/8" ID
	Liquid	2, 4, 6, 8	7/8" ID
50/50%	Hot Gas	1, 3, 5, 7	1 3/8" ID
	Liquid	2, 4, 6, 8	7/8" ID
67/33%	Hot Gas	1, 3, 5, 7	1 3/8" ID
	Liquid	2, 4, 6, 8	7/8" ID
33/33/33%	Hot Gas	1, 7, 3, 5	1 3/8" ID
	Liquid	2, 8, 4, 6	7/8" ID
33/33/17/17%	Hot Gas	1, 7, 3, 5	1 3/8" ID
	Liquid	2, 8, 4, 6	7/8" ID

CONTROL BOX
END

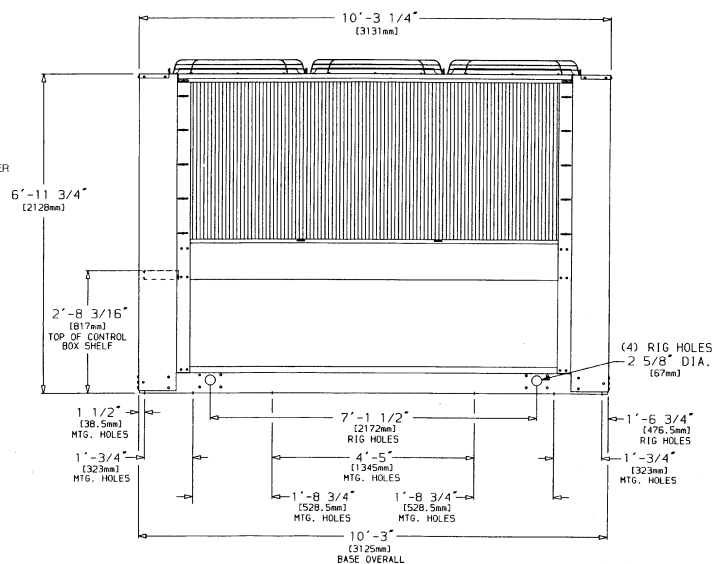
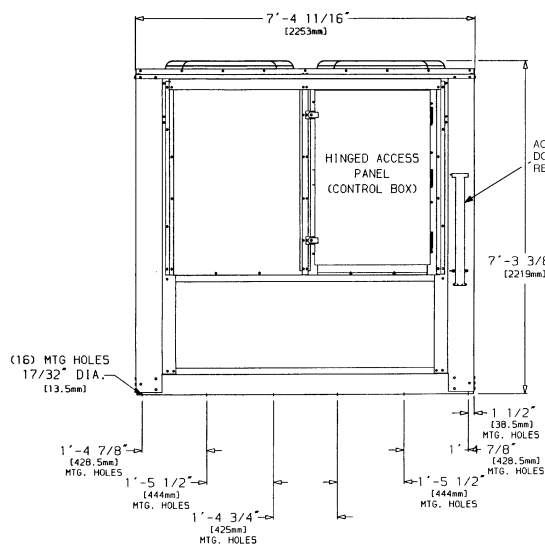
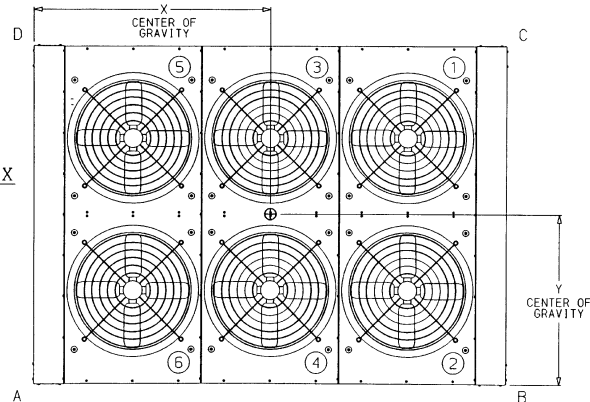

Base unit dimensions (cont)



09DK094 (SEE PAGE 19 FOR POWER WIRING ACCESS HOLES)

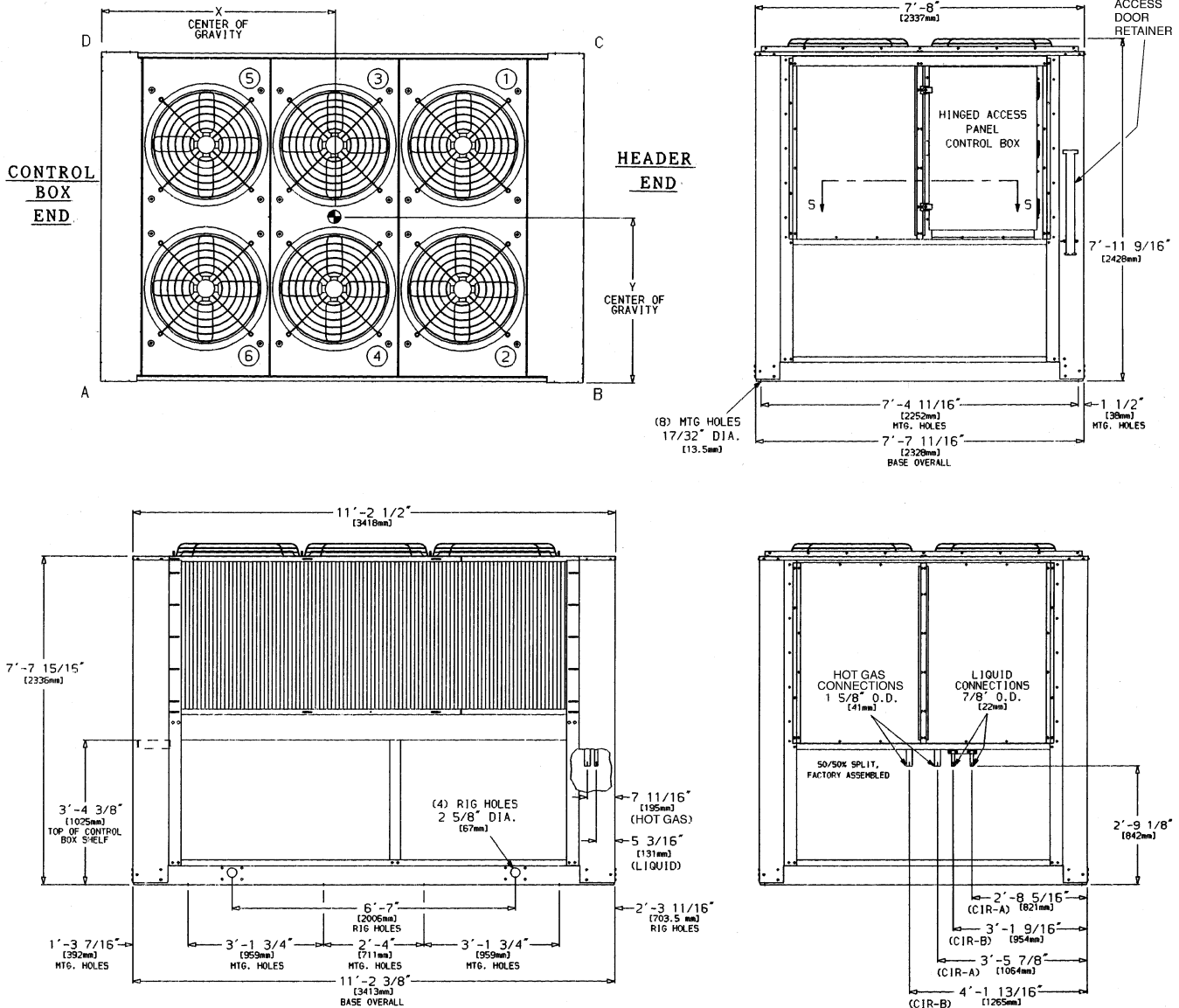

UNIT	DIMENSION Y	DIMENSION X	OPERATING CORNER WEIGHTS			
			A	B	C	D
09DK-094	5'-27/8" [1597 mm]	3'-93/16" [1148 mm]	769 lb [349 kg]	676 lb [307 kg]	658 lbs [299 kg]	747 lb [399 kg]
09DK-094C	5'-27/8" [1597 mm]	3'-93/16" [1148 mm]	960 lb [436 kg]	845 lb [383 kg]	821 lbs [372 kg]	934 lb [424 kg]

NOTES:

- The approximate operating weight of the unit is:
09DK-094 — 2850 lb [1293 kg]
09DK-094C — 3560 lb [1615 kg]
- Unit must have clearances for airflow as follows:
Top — Do not restrict in any way
Ends — 5 ft [1524 mm]
Sides — 6 ft [1829 mm]
- Mounting holes may be used to mount unit to concrete pad. They are not recommended for mounting unit to spring isolators. If spring isolators are used, a perimeter support channel between the unit and the isolators is recommended.
- The letter C after model size refers to copper tube/copper fin coils.

POWER WIRING ACCESS HOLES, 09DK054-094 UNITS

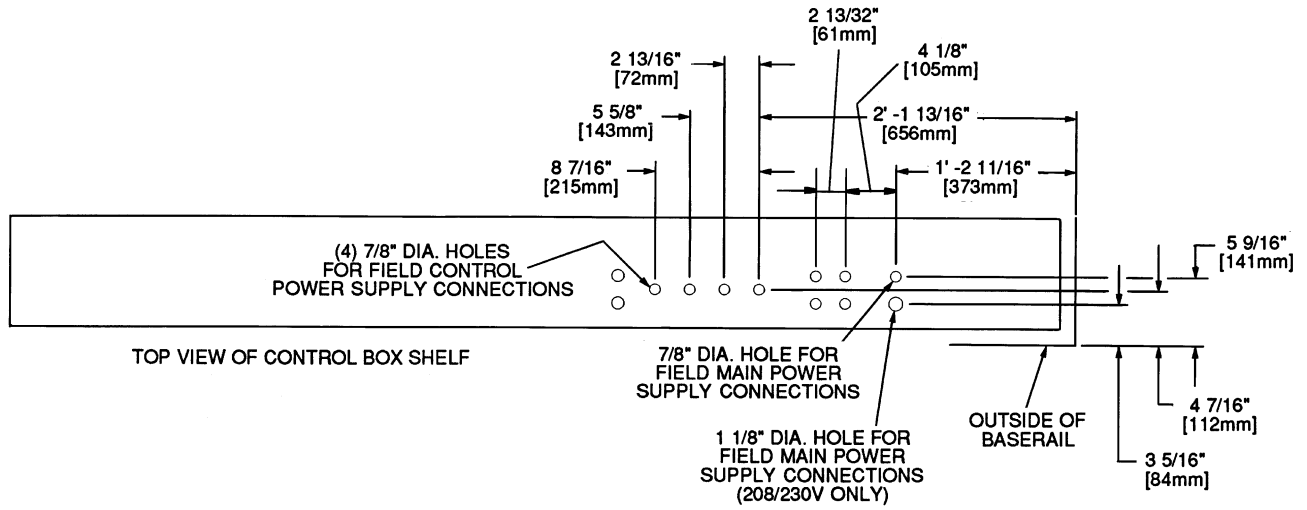

Selection procedure (with example)



I Select minimum or maximum charge ratings.

List the refrigerant, total heat rejection (THR), suction and discharge temperatures as determined from compressor data.

II Determine condensing temperature (saturated discharge temperature minus discharge line loss).

III Determine temperature difference (condensing temperature minus entering-air temperature).

IV Enter Condenser Ratings table (minimum or maximum charge as determined in Step 1) at selected refrigerant and established temperature difference (TD).

Read across to total heat rejection equal to or greater than required. Interpolate if necessary. Read unit size.

EXAMPLE: (Maximum Charge)

Given:

R-22, Maximum Charge	
THR (including subcooling)	29.4 Tons
Saturated Discharge Temperature	123.8 F
Saturated Suction Temperature	40 F
Entering-Air Temperature	95 F
Discharge Line Loss	2 F

$$\text{Cond Temp} = 123.8 \text{ F} - 2 \text{ F} = 121.8 \text{ F}$$

$$\text{TD} = 121.8 \text{ F} - 95 \text{ F} = 26.8 \text{ F}$$

Interpolate in Condenser Ratings table (maximum charge) and obtain capacity of 09DK028 as 29.8 tons and 09DK024 as 23.1 tons. Select the 09DK028.

EXAMPLE: (Minimum Charge)

Given:

R-22, Minimum Charge	
THR	15.6 Tons
Saturated Discharge Temperature	122 F
Saturated Suction Temperature	40 F
Entering-Air Temperature	95 F
Discharge Line Loss	2 F

$$\text{Cond Temp} = 122 \text{ F} - 2 \text{ F} = 120 \text{ F}$$

$$\text{TD} = 120 \text{ F} - 95 \text{ F} = 25 \text{ F}$$

Enter Condenser Ratings table (minimum charge) and select 09DE016 with 15.9 tons THR.

Performance data



Condenser ratings

MINIMUM REFRIGERANT CHARGE (5 F Subcooling)

REFRIG	TD*	TOTAL HEAT REJECTION (Tons)										
		09DE	09DK									
		016	020	024	028	034	044	054	064	074	084	094
12 and 500	10	5.9	7.1	8.4	10.8	13.9	17.3	21.6	24.5	31.1	33.7	37.4
	15	8.8	10.6	12.6	16.2	20.9	26.0	32.1	38.2	46.4	50.2	56.1
	20	11.7	14.3	16.7	21.5	27.8	34.9	42.6	50.6	61.6	66.6	74.7
	25	14.7	17.7	20.9	27.0	34.9	43.3	52.9	63.1	76.6	83.0	93.2
	30	17.6	21.3	25.2	32.3	41.7	52.0	63.3	75.6	91.7	99.4	111.8
	35	20.5	24.9	29.3	37.8	48.8	60.7	74.1	88.2	106.9	116.0	130.6
	40	23.5	28.2	33.4	43.1	55.7	69.4	84.5	100.5	122.2	132.4	149.1
22 and 502	10	6.4	7.5	9.0	11.7	15.1	19.8	23.5	26.6	33.8	36.7	40.7
	15	9.6	11.3	13.5	17.5	22.6	29.7	34.9	41.5	50.5	54.6	61.0
	20	12.7	15.4	18.1	23.2	30.0	39.2	46.4	55.1	67.0	72.5	81.3
	25	15.9	19.2	22.6	29.2	37.6	49.0	57.7	68.8	83.6	90.5	101.7
	30	19.1	23.0	27.2	35.0	45.1	59.0	69.1	82.5	100.1	108.5	122.0
	35	22.3	26.9	31.6	40.8	52.6	68.9	80.7	96.1	116.5	126.4	142.3
	40	25.5	30.5	36.1	46.6	60.2	78.7	92.2	109.7	133.3	144.5	162.7

REFRIG	TD*	TOTAL HEAT REJECTION (Tons)									
		09DK									
		020	024	028	034	044	054	064	074	084	094
134a	10	7.3	8.7	11.4	14.7	19.2	22.8	25.8	32.8	35.6	39.5
	15	11.0	13.1	17.0	22.0	28.8	33.9	40.3	49.0	53.0	59.2
	20	14.9	17.6	22.5	29.1	38.0	45.0	53.5	65.0	70.4	78.9
	25	18.6	21.9	28.3	36.5	47.6	56.0	66.8	81.1	87.8	98.7
	30	22.3	26.4	34.0	43.8	57.3	67.1	80.1	97.2	105.3	118.4
	35	26.1	30.7	39.6	51.0	66.9	78.3	93.3	113.1	122.7	138.2
	40	29.6	35.0	45.2	58.4	76.4	89.5	106.5	129.4	140.3	157.9

MAXIMUM REFRIGERANT CHARGE (15 F Subcooling)

REFRIG	TD*	TOTAL HEAT REJECTION (Tons)										
		09DE	09DK									
		016	020	024	028	034	044	054	064	074	084	094
12 and 500	20	11.2	13.6	15.9	20.5	26.5	34.5	40.5	48.7	59.1	64.3	71.8
	25	14.1	16.9	19.9	25.7	33.2	43.2	50.6	60.6	73.6	80.0	89.7
	30	16.9	20.3	24.0	30.8	39.7	52.0	60.9	72.7	88.3	95.8	107.6
	35	19.7	23.7	27.9	36.0	46.5	60.7	70.8	84.7	103.0	111.7	125.7
	40	22.5	26.9	31.8	41.1	53.1	69.4	80.8	96.7	117.3	127.6	143.5
22 and 502	20	12.3	14.7	17.2	22.1	28.6	37.3	43.8	52.6	63.8	69.4	77.5
	25	15.3	18.3	21.5	27.8	35.8	46.7	54.7	65.5	79.5	86.5	96.9
	30	18.4	21.9	25.9	33.3	43.0	56.2	65.8	78.6	95.4	103.5	116.3
	35	21.5	25.6	30.1	38.9	50.1	65.6	76.4	91.4	111.2	120.6	135.7
	40	24.6	29.1	34.4	44.4	57.3	75.0	87.3	104.5	126.8	137.9	155.1

REFRIG	TD*	TOTAL HEAT REJECTION (Tons)									
		09DK									
		020	024	028	034	044	054	064	074	084	094
134a	20	14.3	16.8	21.5	27.9	36.4	42.7	51.3	62.2	67.6	75.6
	25	17.8	20.9	27.0	34.7	45.3	53.3	63.8	77.5	84.3	94.5
	30	21.3	25.2	32.3	41.8	54.6	64.1	76.6	93.0	100.9	113.3
	35	25.0	29.2	37.7	48.6	63.6	74.5	89.1	108.4	117.5	132.2
	40	28.4	33.4	43.1	55.6	72.8	85.1	101.8	123.6	134.4	151.1

*TD (Temperature Difference) = Saturated Condensing Temperature (entering) — Entering-Air Temperature.

NOTES:

1. Minimum charge gives higher heat rejection, since entire surface of condenser and subcooling circuit is used for condensing only. Minimum charge ratings, however, do not represent greatest potential system capacity. They are comparable to competitive ratings without subcooling.
2. Use maximum charge when compressor, condenser, and evaporator are selected as a package and the components balanced to secure maximum benefits of 15 F subcooling (for example, in selecting 09DK condensers with Carrier compressor rated at 15 F

subcooling). Maximum charge activates the subcooling circuit, resulting in higher system capacity at slightly higher head pressure and corresponding condensing temperature. Liquid refrigerant leaves the system subcooled to a stable condition to allow greater length of refrigerant run or lift. See Application Data section, page 27, for available liquid lift information.

3. Condenser subcooling = Saturated condensing temperature of refrigerant — Actual temperature of refrigerant leaving the coil.

Electrical data



		UNIT				FAN MOTORS				
Model	Volts	Phase	kW	MCA	MOCP	Total Fans	Phase	Hp	FLA (ea)	
09DE	016	208-230	1.41	10.4	15	2	1	1/2	4.3	
		460*		5.2					2.3	
09DK	020	208/230	1.92	14.8	25	2	3/4	3/4	6.6	
		460		7.4					15	3.3
		575		7.6					15	3.4
		380		8.8					15	3.9
	024	208/230	2.26	14.8	25	2	3/4	3/4	6.6	
		460		7.4					15	3.3
		575		7.6					15	3.4
		380		8.8					15	3.9
	028	208/230	2.98	14.8	25	2	1	1	6.6	
		460		7.4					15	3.3
		575		7.6					15	3.4
		380		8.8					15	3.9
034	208/230	3.86	21.4	30	3	3	1	6.6		
	460		10.7					15	3.3	
	575		11.0					15	3.4	
	380		12.7					20	3.9	
044	208/230	4.53	21.4	30	3	1	1	6.6		
	460		10.7					15	3.3	
	575		11.0					15	3.4	
	380		12.7					20	3.9	
054,064	208/230	6.20	25.8	30	4	1	1	(1,2) 5.5 (3,4) 6.6		
	460		12.9					15	(1,2) 2.8 (3,4) 3.3	
	575		14.5					15	(1-4) 3.4	
	380/415		13.7					15	(1,2) 3.0 (3,4) 3.4	
074-094	208/230	9.30	39.0	45	6	1	1	(1,2) 5.5 (3-6) 6.6		
	460		19.5					20	(1,2) 2.8 (3-6) 3.3	
	575		21.3					25	(1-6) 3.4	
	380/415		20.5					25	(1,2) 3.0 (3-6) 3.4	

LEGEND

- FLA — Full Load Amps
- kW — Total Fan Motor Power Input
- MCA — Minimum Circuit Amps, Complies with NEC, Article 430-24
- MOCP — Maximum Overcurrent Protection (Amps)
- NEC — National Electrical Code
- UL — Underwriters' Laboratories



*The 09DE016 unit is factory wired for 208-230 volts. It may be readily field converted to 460 volts.

NOTES:

1. Maximum allowable phase imbalance:
Voltage = 2%; Amps = 10%
2. Units are UL and UL, Canada approved for 208/230, 460 and 575 v.

CONTROL CIRCUIT DATA (09DK020-094)

MAIN POWER VOLTAGE V-Ph-Hz	CONTROL VOLTAGE V-Ph-Hz	OVERCURRENT PROTECTION AMPS	
		020-044	054-094
208/230-3-60	115-1-60	7	10
460-3-60	115-1-60	7	10
575-3-60	115-1-60	7	10
380-3-60	230-1-60	7	10

NOTES:

1. 10 va is required for the 09DK020-044 control circuit, and 100 va is required for the 09DK054-094 control circuit.
2. Control circuits for the 09DE are not factory supplied. Fan contactors for these units are field supplied.

Typical wiring schematic

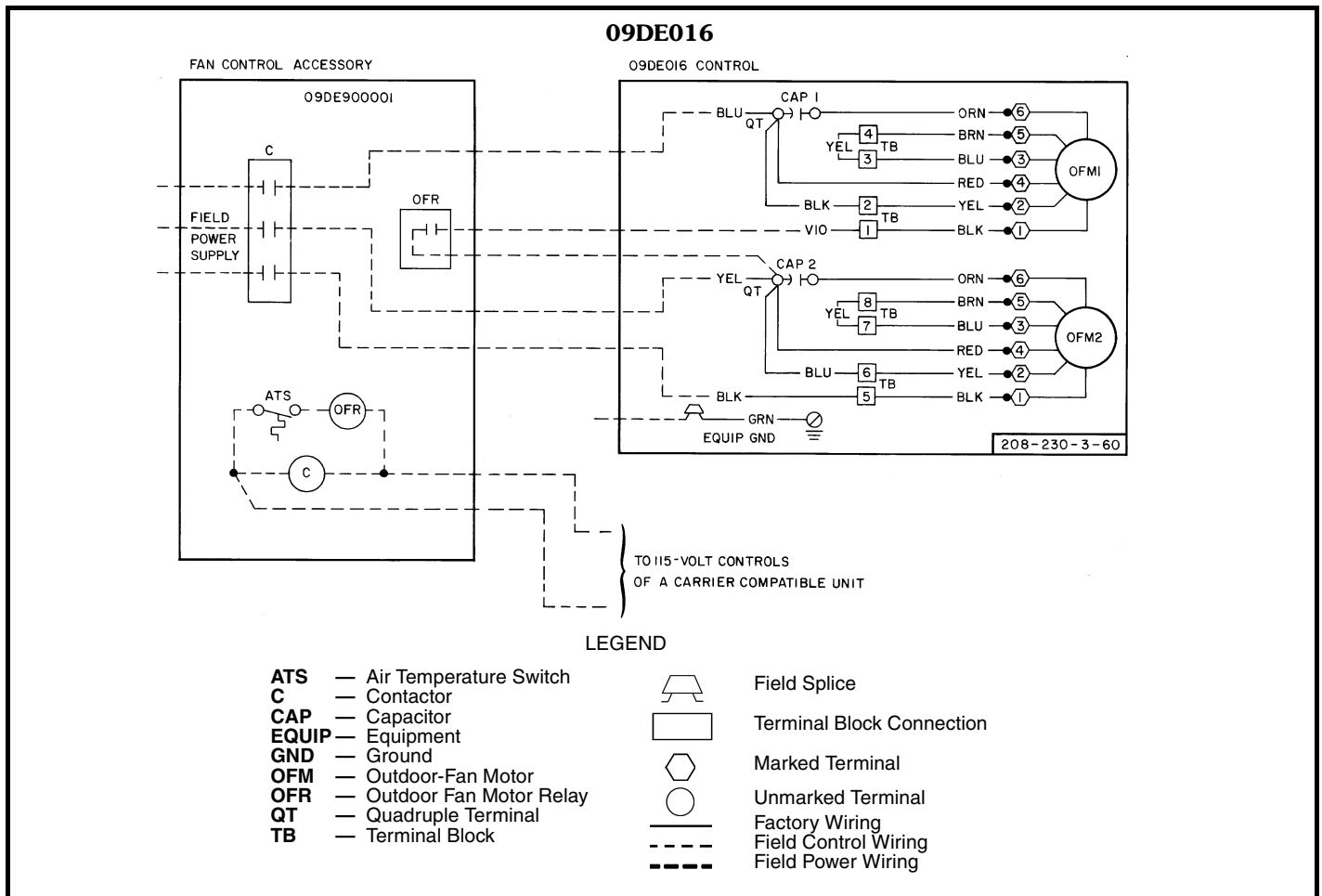

Typical wiring schematic (cont)



09DK020-044

ACCESSORY PKG. WIRING

POWER SCHEMATIC

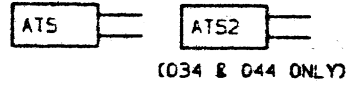
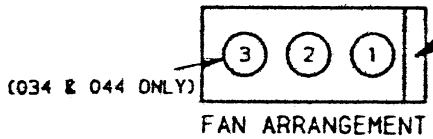
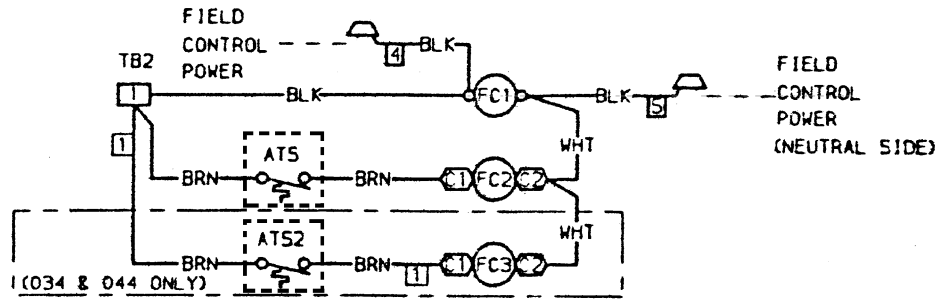
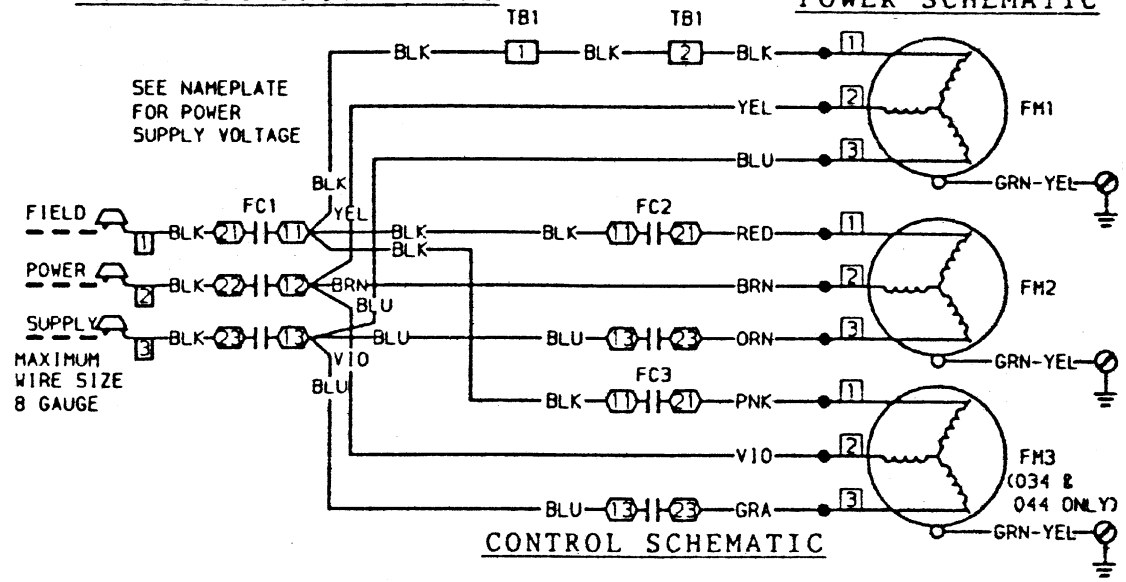

LEGEND

- ATS — Air Temperature Switch
- FC — Fan Contactor
- FM — Fan Motor
- TB — Terminal Block
- Field Splice
- Terminal Block Connection
- Marked Terminal
- Unmarked Terminal
- Factory Wiring
- Field Control Wiring
- Field Power Wiring

09DK074-094

09DK074-094 POWER SCHEMATIC

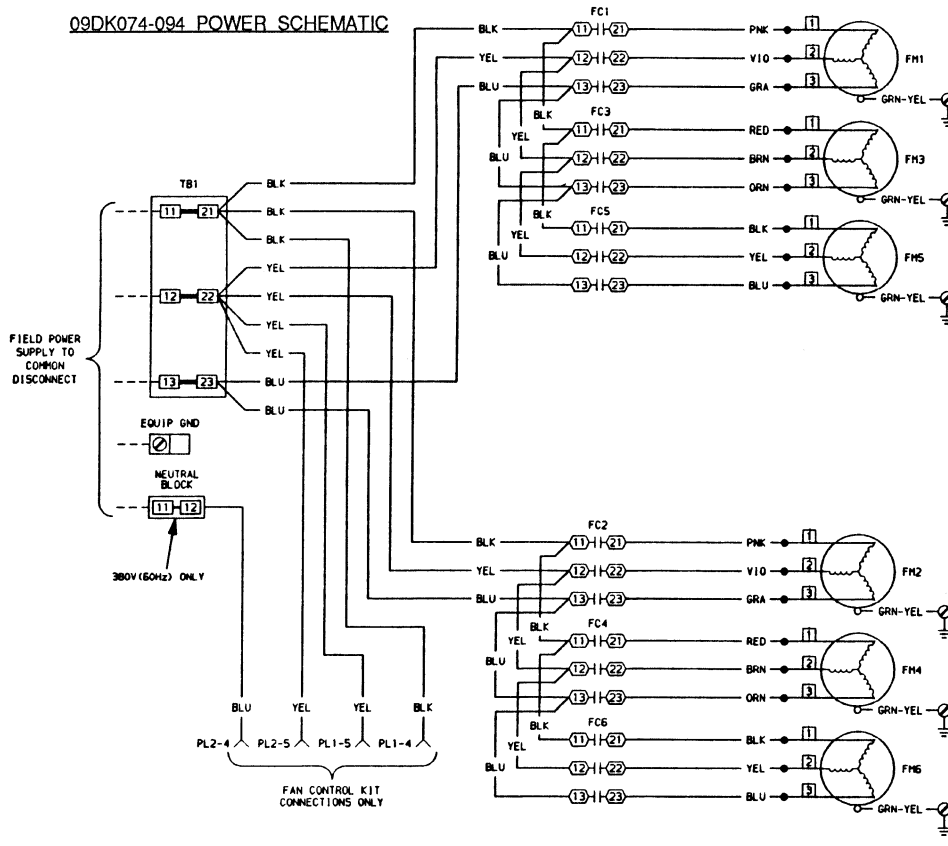

- LEGEND**
- ATS — Air Temperature Switch
 - EQUIP — Equipment
 - FC — Fan Contactor
 - FCPS — Fan Cycling Pressure Switch
 - FM — Fan Motor
 - GND — Ground
 - PL — Plug
 - TB — Terminal Block
 - Terminal Block Connection
 - Marked Terminal
 - Unmarked Terminal
 - Factory Wiring
 - Field Control Wiring
 - Field Power Wiring

09DK074-094 STANDARD CONTROL SCHEMATIC (100% & 50%/50% CAPACITY SPLITS)

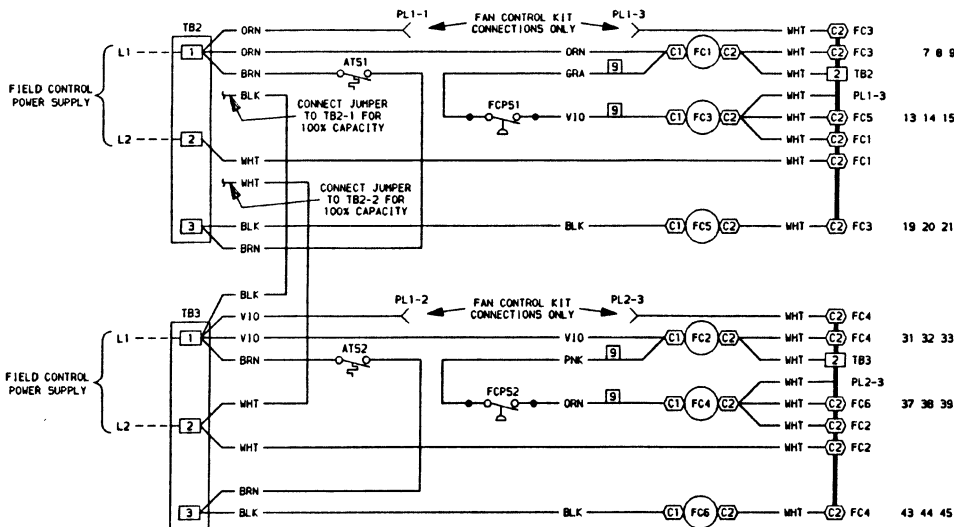

09DK CONDENSER WITH SINGLE COMPRESSOR

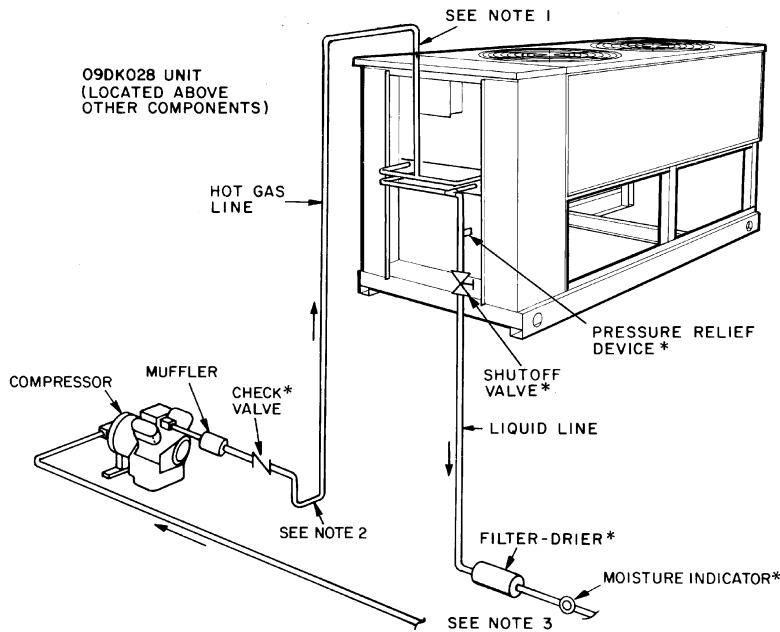

*Field supplied.

NOTES:

- Hot gas lines should rise above refrigerant level in condenser circuit. Double riser may be required; check compressor minimum capacity.
- Trap should be installed on hot gas lines to prevent condenser oil and refrigerant vapor migration from accumulating on compressor heads during off cycle.
- Refer to Carrier System Design Manual, part 3, or the Carrier E20-II® Software Refrigerant Piping program, for proper piping sizes and design.
- Pitch all horizontal lines downward in the direction of refrigerant flow.
- For piping lengths greater than 50 ft, provide support to liquid and gas lines near the connections to the coil.
- Single-phase motors (09DE016) require one field-supplied contactor to start all fans. Field-supplied contactors are not required when accessory fan cycling control package is furnished.
- Wiring and piping shown are general points-of-connection guides only and do not include details required for specific installations.
- All wiring must comply with applicable national and local codes.
- All piping must follow standard refrigerant piping practices.
- For pressure relief requirements, see latest revision of ASHRAE (American Society of Heating, Refrigeration, and Air Conditioning Engineers) Standard 15, Safety Code for Mechanical Refrigeration.
- All 09DK units have factory-installed contactors.

09DK CONDENSER WITH DUAL SPLIT SYSTEM

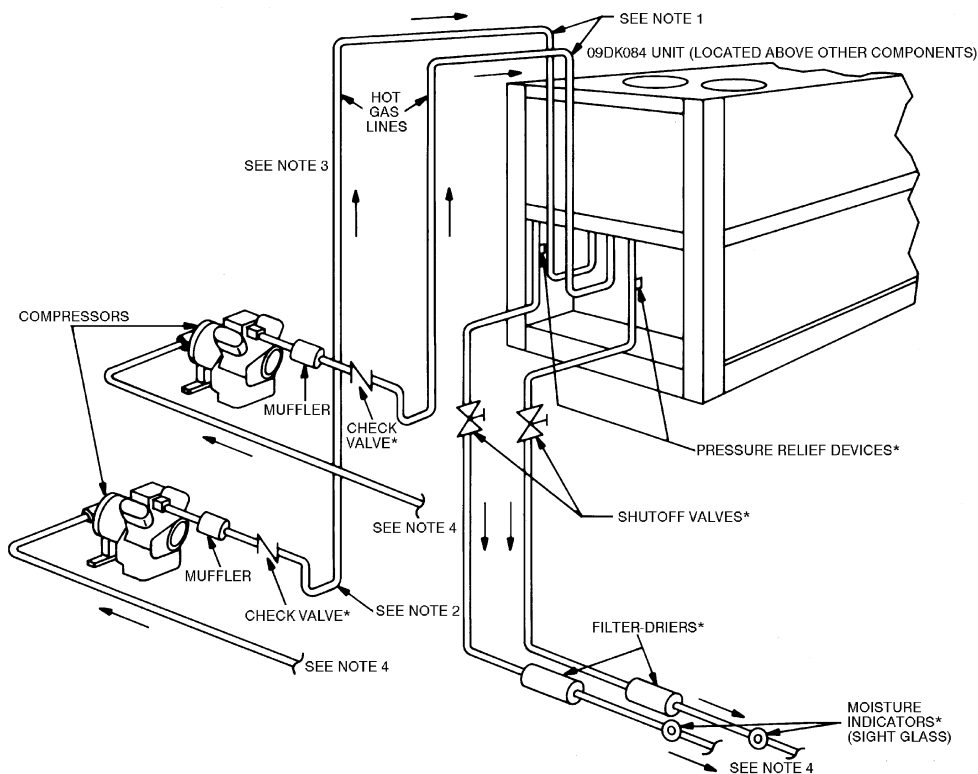

Application data



Unit performance with ductwork

Ductwork added to equipment installed indoors results in added external static pressure, which affects fan performance and condenser capacity. The table below lists performance comparisons for operating with free air discharge and various external static pressures.

PERFORMANCE COMPARISONS — FREE AIR DISCHARGE VS STATIC PRESSURES

EXTERNAL STATIC (in. wg)	% CFM DECREASE	% THR DECREASE	APPROX % SYSTEM DECREASE
0.1	8.5	5.2	2.6
0.2	14.2	8.9	4.9
0.3	19.8	12.2	6.1
0.4	24.9	16.1	8.1
0.5	29.9	19.1	9.6

THR — Total Heat Rejection

Liquid lift

The amount of liquid lift available before refrigerant flashing occurs depends on the amount of liquid subcooling in the system.

All 09DE and 09DK condensers have positive subcooling when applied with an optimum charge. With subcooling, it is possible to overcome an appreciable friction drop and/or static head (due to the elevation of the liquid metering device above the condenser).

When 09DE and 09DK condensers are applied with a minimum charge, minimal subcooling in the condenser is realized; therefore, if subcooling is required it must be obtained by external means such as a liquid suction inter-changer.

The average amount of liquid lift available from the 09DE and 09DK condensers is shown in the accompanying table.

AVAILABLE LIQUID LIFT (ft)*

REFRIGERANT		R-22		R-502		R-134a	
Unit		Temperature Difference (F)†					
		20	30	20	30	20	30
09DE	016	75	71	75	70	—	—
	020,024	77	67	77	61		
09DK	028	78	68	78	62	—	—
	034	80	70	80	64		
	044	75	65	75	60		
	054	60	50	60	44	29	26
	064	41	31	41	25	20	6
	074	44	34	44	28	18	7
	084	51	41	51	35	22	10
	094	41	31	41	25	18	1

*Allows 7 psi drop for liquid line accessories and 2° F liquid line loss with maximum charge.

†Saturated Condensing Temperature (entering) – Entering Air Temperature (dry bulb) °F.

NOTES:

1. Data based on 15 F subcooling, and unit circuiting of 100% for the 09DE units, and 50/50% or 53/47% for the 09DK units.
2. Available subcooling is greatly reduced when R-12 or R-500 is used in these units. It is recommended that the evaporator is at the same level as the condenser, or lower.
3. Subcooling = Saturated condensing temperature of refrigerant — Actual temperature of refrigerant leaving the coil.

Application data (cont)



Multiple condenser arrangements

09DE,DK

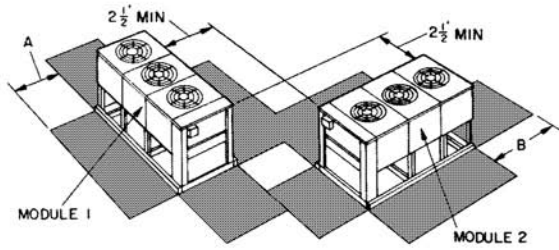

PERPENDICULAR

09DE,DK

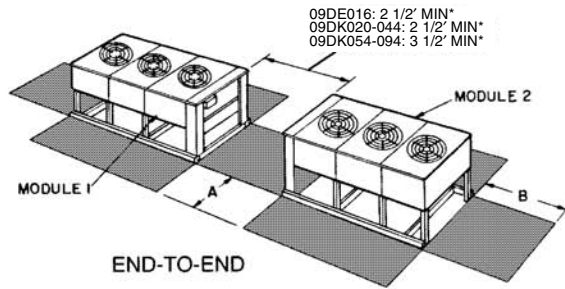

END-TO-END

09DE016

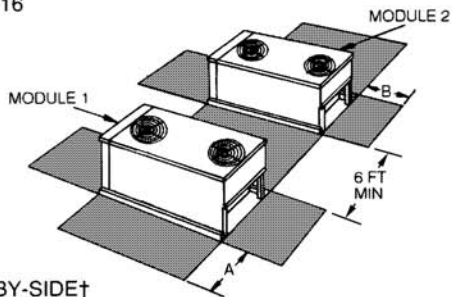

SIDE-BY-SIDE†

09DK (020-044 only)

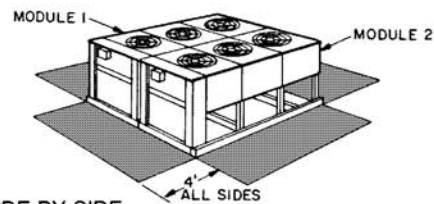

SIDE-BY-SIDE

09DK (054-094 only)

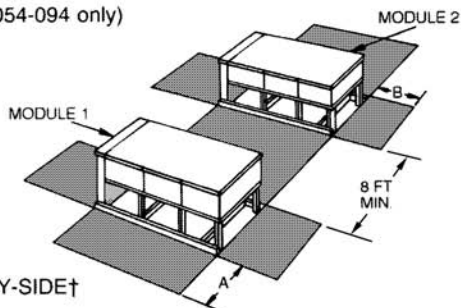

SIDE-BY-SIDE†

Space for Service and Airflow

*For clearances between controls and grounded surfaces, check local codes.

†Observe minimum recommended space requirements.

09		DIMENSIONS (ft)	
		A	B
DE	016	3	2
	020,024	4	4
	028		
	034 044		
DK	054	6	5
	064		
	074		
	084		
	094		



Head pressure control

General — Efficient operation of the evaporator thermostatic expansion valves requires a 90 F minimum saturated condensing temperature when compressors are operating at 100% capacity, 80 F for 75% compressor capacity, and 70 F for 50 and 25% compressor capacity.

A drop in entering outdoor-air temperature results in a lower saturated condensing temperature. When the outdoor-air temperature drops below the minimum temperatures listed in the Minimum Outdoor-Air Operating Temperature table on page 30, head pressure control is required.

Head pressure controls — Head pressure on the 09DE016 and 09DK020-094 units may be controlled by fan cycling supplemented by Motormaster® control. Fan cycling control is available as an accessory on the 09DE and 09DK020-044 units. Motormaster I is also available on these units with fan cycling.

On 09DK054-094 condensers, fan cycling controls are standard (nominal 67/33%, 33/33/33%, 33/33/17/17%). Head pressure can also be controlled by fan cycling controls supplemented by the accessory Motormaster V solid-state head pressure controller. See accessory installation instructions for more information.

Fan cycling — The fan cycling control, used primarily during intermediate seasons, cycles one fan on the 09DE016 unit, one fan on 09DK020-028 units, 2 fans on 09DK034-064 units, and 4 fans on 09DK074-094 units.

Motormaster I head pressure control (09DE, 09DK020-044) — When outdoor temperatures are low enough to cause low condensing pressures, the Motormaster control modulates the motor speed of one condenser fan from full to zero rpm to maintain a constant saturated condensing temperature for full year-round head pressure control. The Motormaster I control can be used only with suitable motors. It may be used as the sole control on single-fan units but must be used in conjunction with fan cycling control on multiple-fan units. If condensers 09DK020-044 are applied to separate refrigeration cycles,

special problems arise when controlling head pressure from a single control point. For such applications, more positive system control can be ensured by using individual condensers and head pressure controls.

Motormaster V head pressure control — Available for 09DK054-094 units only, this head pressure control maintains the proper condensing temperature at low ambient temperature conditions to -20 F and is compatible with the standard factory-installed 3-phase motors (in positions 1 and 2).

Process applications

Process applications are defined as heat rejection loads that are not related to or significantly affected by outside ambient conditions. Process applications tend to have constant heat rejection requirements throughout the year. Consequently, these applications may require switching the set points on standard accessory fan cycle controls. Consult Application Engineering for assistance in designing and selecting process systems.

E-coated aluminum-fin and copper fin coils

E-coated aluminum-fin coils have a flexible and durable epoxy coating uniformly applied to all coil surfaces. Unlike brittle phenolic dip and bake coatings, E-coat provides superior protection with unmatched flexibility, edge coverage, metal adhesion, thermal performance, and most importantly, corrosion resistance.

E-coated coils provide this protection since all coil surfaces are completely encapsulated from environmental contamination. This coating is especially suitable in industrial environments.

E-coated copper-fin coils have the same flexible and durable epoxy coating as E-coated aluminum-fin coils. However, this option combines the natural salt and environmental resistance of all-copper construction with high levels of corrosion protection. This coating is recommended for harsh combinations of coastal and industrial environments.

Application data (cont)



MINIMUM OUTDOOR-AIR OPERATING TEMPERATURE

UNIT	HEAD PRESSURE CONTROL	TD	COMPRESSOR CAPACITY %*				
			100	75	50	25	
			Minimum Outdoor Temperature (F) (See Note 2)				
09DE016	None	30	60	57	55	62	
		25	65	61	57	64	
		20	70	65	60	65	
	Fan Cycling, One Fan	30	35	40	44	58	
		25	45	47	49	60	
		20	54	54	53	63	
Motormaster® I Control	30	-20	-20	-20	-20		
	25	-20	-20	-20	-20		
	20	-20	-20	-20	-20		
09DK	020-028	None	30	60	57	55	62
			25	65	61	57	64
			20	70	65	60	65
		Fan Cycling, One Fan	30	29	34	38	51
			25	38	40	42	53
			20	47	47	46	56
	Motormaster I Control	30	-20	-20	-20	-20	
		25	-20	-20	-20	-20	
		20	-20	-20	-20	-20	
	034, 044	None	30	60	57	55	62
			25	65	61	57	64
			20	70	65	60	65
		Fan Cycling, 2 Fans	30	12	19	22	43
			25	22	25	29	47
			20	31	31	36	51
	Motormaster I Control	30	-20	-20	-20	-20	
		25	-20	-20	-20	-20	
		20	-20	-20	-20	-20	
054, 064	FCPS, 2 Fans†	30	29	34	38	51	
		25	38	40	42	53	
		20	47	47	46	56	
	Motormaster V Control	30	-20	-20	-20	-20	
074-094	FCPS 2 Fans, ATS 2 Fans†	30	12	19	22	43	
		25	22	25	29	47	
		20	31	31	36	51	
	Motormaster V Control	30	-20	-20	-20	-20	
		25	-20	-20	-20	-20	
		20	-20	-20	-20	-20	

LEGEND

Intermediate Season

Winter Season

ATS — Air Temperature Switch

FCPS — Fan Cycling Pressure Switch

TD — Temperature Difference

= Saturated Condensing Temperature (Entering)

- Entering-Air Temperature

*Interpolation permitted.

†Additional FCPSs are needed for nominal 67/33, 33/33/33, and 33/33/17/17% capacity split applications.

NOTES:

- Fans on the 09DK054-094 units are controlled by an ATS or FCPS.
- Minimum outdoor temperatures are determined for indoor and outdoor unit combinations of the same capacity. However, for 09DK020 (17½ ton) outdoor unit, the minimum outdoor temperatures shown are determined for combination with a 15-ton indoor unit.



Air-Cooled Condensing Units

HVAC Guide Specifications

Size Range: **15 to 40 Tons, Nominal**

Carrier Model Numbers: **09DE, 09DK**

Part 1 — General

1.01 SYSTEM DESCRIPTION

Outdoor mounted, air-cooled condenser. Air shall discharge vertically.

1.02 QUALITY ASSURANCE

Unit shall be rated using refrigerants 12, 22, 134a, 500, 502. Ratings shall be listed at minimum (5° F subcooling) and maximum (15° F subcooling) refrigerant charge.

Units shall be UL approved and coils shall be leak tested at 420 psig (480 psig on 09DK) air pressure.

1.03 DELIVERY, STORAGE, AND HANDLING

Unit shall be stored and handled per manufacturer's instructions.

Part 2 — Products

2.01 EQUIPMENT

A. General:

Outdoor mounted, packaged, air-cooled remote condenser. Unit shall be complete with cooling coils, fans, fan motors, and electrical controls.

B. Cabinet:

Cabinet shall be of welded steel frame construction with removable electrical control cover. Hinged panel allows access to electrical control box on 09DK units. Panels shall be of zinc-coated bonderized steel finished with baked enamel. Unit casing shall be capable of withstanding ASTM Standard B117 500-hour salt spray test.

C. Fan(s):

Fan(s) shall be of the propeller type, direct driven by weatherproof motors, and dynamically balanced. Fan(s) shall be arranged for vertical discharge with horizontal suction.

D. Coils:

Coils shall use copper tubes, aluminum plate fins (or optional copper tubes, copper fins) and galvanized steel tube sheets. Fins shall be bonded to tubes by mechanical expansion. Hot gas and liquid connections shall be made from the same end.

All coils shall be shipped with no refrigerant holding charge (dry air only).

09DE016 — each coil shall be capable of field connection for splits of 100% or 50/50%.

09DK — each coil shall be capable of field connection for splits of 100%, 50/50%, 67/33%, (020 and 024 size); 100%, 60/40%, 50/50%, 40/40/20% (028 and 034 sizes); and

100%, 73/27%, 67/33%, 60/40%, 53/47%, 40/34/13/13% (044 size).

E. Motors:

Motors shall be weatherproof and inherently protected to operate at the specified electrical characteristics. The 09DE fan motors are single phase. 09DK fan motors shall be 3-phase, TEAO (Totally Enclosed, Air Over).

F. Operating Characteristics:

Unit shall be capable of rejecting the required heat at the required cfm and be capable of operating at moderate ambient temperatures as standard, and down to -20 F with the head pressure controller.

G. Electrical Characteristics:

Unit shall be capable of operating on three-phase. Electrical characteristics shall be specified on the equipment schedule.

H. Special Features:

Certain standard features are replaced with features designated by * are specified. See your local Carrier Sales Office for amending specifications.

* 1. Fan Cycling Control:

Cycles one or two fans to maintain head pressure.

* 2. Head Pressure Controller:

Modulates the speed of one fan in response to low outdoor temperature and provides operation down to -20 F when used with accessory fan cycling control.

3. Condenser Coil Options:

a. Pre-Coated Aluminum-Fin Coils:

Shall have a durable epoxy-phenolic coating to provide protection in mildly corrosive coastal environments. Coating shall be applied to the aluminum fin stock prior to the fin stamping process to create an inert barrier between the aluminum fin and copper tube. Epoxy-phenolic barrier shall minimize galvanic action between dissimilar metals.

b. Copper-Fin Coils:

Shall be constructed of copper fins mechanically bonded to copper tubes and copper tube sheets. Galvanized steel tube sheets shall not be acceptable. All copper construction shall provide protection in moderate coastal applications.

A polymer strip shall prevent the coil assembly from contacting the sheet metal coil pan to minimize the potential for galvanic corrosion between the coil and the pan. All copper construction shall provide protection in moderate coastal environments.

Guide specifications — 09DE and 09DK020-044 (cont)



c. E-Coated Aluminum-Fin Coils:

Shall be constructed of aluminum fins mechanically bonded to copper tubes. Coating process shall have a flexible epoxy polymer coating uniformly applied to all coil surfaced without material bridging between the fins. The coating process shall ensure complete coil encapsulation. Color shall be high-gloss black with gloss at 60° of 65% to 90% per ASTM D523-89. Uniform dry film thickness shall be 0.8 mil to 1.2 mil on all surfaces, including the fin edges. Superior hardness characteristics shall meet those requirements of 2H, per ASTM D3363-92A. Cross-hatch adhesion shall meet the requirements of 4B-5B, per ASTM D3359-93. Impact resistance shall be up to 160 in./lb, per ASTM D2794-93. Humidity resistance shall be up to a minimum of 1000 hours per ASTM D2247-92. Water immersion resistance shall be up to a minimum of 250 hours per ASTM D870-92. Durability shall be confirmed through testing to no less than 1000 hours of salt spray per ASTM B117-90.

d. E-Coated Copper Fin Coils:

Shall be copper fins mechanically bonded to copper tubes with copper tube sheets. Coating process shall have a flexible epoxy polymer coating uniformly applied to all coil surfaces without a material bridging between the fins. The coating process shall ensure complete coil encapsulation. Shall be high-gloss black with gloss at 60° of 65% to 90% per ASTM D523-89. Uniform dry film thickness shall be 0.8 mil to 1.2 mil on all surfaces, including the fin edges. Superior hardness characteristics shall meet those requirements of 2H, per ASTM D3363-92A. Cross-hatch adhesion shall meet the requirements of 4B-5B, per ASTM D3359-93. Impact resistance shall be up to 160 in./lb, per ASTM D2794-93. Humidity resistance shall be up to a minimum of 1000 hours per ASTM D2247-92. Water immersion resistance shall be up to a minimum of 250 hours per ASTM D870-92. Durability shall be confirmed through testing to no less than 1000 hours of salt spray per ASTM B117-90.

4. Coil Grille (09DE only):

Protects condenser coil from damage. Shall be constructed from expanded aluminum (not intended as hail guard).

Air-Cooled Condensing Units

HVAC Guide Specifications

Size Range: **50 to 90 Tons, Nominal**

Carrier Model Number: **09DK**

Part 1 — General

1.01 SYSTEM DESCRIPTION

Outdoor mounted, split system air-cooled condenser, utilizing electromechanical fan cycling controls. Air shall enter horizontally and vertically and discharge vertically.

1.02 QUALITY ASSURANCE

- A. Unit shall be rated using refrigerants 12, 22, 134a, 500, and 502. Ratings shall be at minimum (5° F subcooling) and maximum (15° F subcooling) refrigerant charge.
- B. Unit construction shall be designed to conform to ASHRAE 15 latest revision safety standard and NEC.
- C. Units shall be UL and UL, Canada approved (208/230, 460, 575 v).
- D. Unit shall be manufactured according to ISO 9001:2000 manufacturing quality standard.
- E. Unit operation shall be tested at the factory.

1.03 DELIVERY, STORAGE, AND HANDLING

Unit shall be stored and handled according to manufacturer's instructions.

Part 2 — Products

2.01 EQUIPMENT

A. General:

Outdoor mounted, packaged, air-cooled remote condenser unit shall be complete with coils, fans, fan motors, and electrical controls.

B. Unit Cabinet:

1. Frame shall be heavy-gage galvanized steel members.
2. Galvanized steel casing, zinc phosphated, with an electrostatically applied baked enamel finish.
3. Unit casing shall be capable of withstanding ASTM Standard B117 500-hour salt spray test.
4. Control box shall be equipped with a hinged access door.

C. Fans:

Condenser fans shall be direct-driven propeller type discharging air vertically upward and shall be equipped with the following features:

1. Permanently lubricated bearings.
2. PVC coated steel wire safety guards.
3. Inherent corrosion-resistant shafts.
4. Statically and dynamically balanced propeller fans.

D. Coils:

1. Coil shall be air-cooled with integral subcooler, constructed of aluminum fins mechanically bonded to seamless copper tubes which are then cleaned, dehydrated, and sealed. Copper tube/fin combination available as an option.
2. Coils shall be leak tested at 280 psig (1931 kPa) and pressure tested at 450 psig minimum (3103 kPa).
3. Hot gas and liquid connections shall be made from the same end.
4. Coil shall be capable of field connection for nominal splits of 100%, 50/50%, 67/33%, 33/33/33%, and 33/33/17/17% (50 to 80 ton units) or 100%, 50/50% (90 ton units).
5. All coils shall be shipped with dry air holding charge, not refrigerant.

E. Refrigeration Components:

A tubing package for headering shall be provided for 100%, 50/50%, and nominal 67/33% capacity split applications. The package shall include hot gas and liquid line piping 1/4-in. male flare fittings, valve cores, fan cycle pressure switches, and the necessary hardware for installation.

F. Motors:

Condenser-fan motors shall be 3-phase and shall be protected against single-phasing conditions. All motors shall have permanently lubricated sealed bearings. Fans 1 and 2 shall use open drip-proof motors that are compatible with the head pressure controller accessory. The remaining fan motors shall be totally enclosed fan-cooled (208-230/460-v units). All motors on 380-v and 575-v units shall be open drip-proof.

G. Operating Characteristics:

Unit shall be capable of rejecting the required heat at the required cfm and be capable of operating down to moderate ambient temperatures with standard factory-supplied fan cycling. Operation to -20 F shall be possible with the head pressure control accessory.

H. Electrical Characteristics:

1. A dual power supply of the correct voltage is required for each series unit; a 3-phase power circuit voltage and a single-phase control circuit voltage. The number of control circuits will depend on the capacity split application utilized. Power supplies for all units shall enter the control box through factory-punched entrance holes in the control box shelf. Terminal blocks shall be supplied for field wiring connections.
2. The units shall utilize electromechanical fan cycling head pressure controls to control each fan separately.

I. Special Features:

Certain standard features are replaced when features designated by * are specified. See your local Carrier Sales Office for amending specifications.

1. Condenser Coil Options:

a. Pre-Coated Aluminum-Fin Coils:

Shall have a durable epoxy-phenolic coating to provide protection in mildly corrosive coastal environments. Coating shall be applied to the aluminum fin stock prior to the fin stamping process to create an inert barrier between the aluminum fin and copper tube. Epoxy-phenolic barrier shall minimize galvanic action between dissimilar metals.

b. Copper-Fin Coils:

Shall be constructed of copper fins mechanically bonded to copper tubes and copper tube sheets. Galvanized steel tube sheets shall not be acceptable. All copper construction shall provide protection in moderate coastal applications.

A polymer strip shall prevent the coil assembly from contacting the sheet metal coil pan to minimize the potential for galvanic corrosion between the coil and the pan. All copper construction shall provide protection in moderate coastal environments.

c. E-Coated Aluminum-Fin Coils:

Shall be constructed of aluminum fins mechanically bonded to copper tubes. Coating process shall have a flexible epoxy polymer coating uniformly applied to all coil surfaced without material bridging between the fins. The coating process shall ensure complete coil encapsulation. Color shall be high-gloss black with gloss at 60° of 65% to 90% per ASTM D523-89. Uniform dry film thickness shall be 0.8 mil to 1.2 mil on all surfaces, including the fin edges. Superior hardness characteristics shall meet those requirements of 2H, per ASTM D3363-92A. Cross-hatch adhesion shall meet the requirements of 4B-5B, per ASTM D3359-93. Impact resistance shall be up to 160 in./lb, per ASTM D2794-93. Humidity resistance shall be up to a minimum of 1000 hours per ASTM D2247-92. Water immersion resistance shall be up to a minimum of 250 hours per ASTM D870-92. Durability shall be confirmed through testing to no less than 1000 hours of salt spray per ASTM B117-90.

d. E-Coated Copper Fin Coils:

Shall be copper fins mechanically bonded to copper tubes with copper tube sheets. Coating process shall have a flexible epoxy polymer coating uniformly applied to all coil surfaces without a material bridging between the fins. The coating process shall ensure complete coil encapsulation. Shall be high-gloss black with gloss at 60° of 65% to 90% per ASTM D523-89. Uniform dry film thickness shall be 0.8 mil to 1.2 mil on all surfaces, including the fin edges. Superior hardness characteristics shall meet those requirements of 2H, per ASTM D3363-92A. Cross-hatch adhesion shall meet the requirements of 4B-5B, per ASTM D3359-93. Impact resistance shall be up to 160 in./lb, per ASTM D2794-93. Humidity resistance shall be up to a minimum of 1000 hours per ASTM D2247-92. Water immersion resistance shall be up to a minimum of 250 hours per ASTM D870-92. Durability shall be confirmed through testing to no less than 1000 hours of salt spray per ASTM B117-90.

2. Fan Sound Reduction Kit:

Fan sound reduction kits reduce system noise without compromising performance.

3. Security Grilles:

The PVC-coated grilles protect the condenser coil from damage due to debris and vandalism.

4. Control Transformer:

The transformer is used to convert 200/230/460 v to 115 v for use on 115-v control systems, utilizing power from the condenser main unit power connection.

5. Head Pressure Controller:

This accessory allows the unit to operate at low ambient conditions to -20 F.

6. Hail Guard:

Louver-type sheet metal hail guard design prevents damage to condenser coil due to hail and other flying debris.

Carrier Corporation • Syracuse, New York 13221 1203 10-02



Carrier

A United Technologies Company

Manufacturer reserves the right to discontinue, or change at any time, specifications or designs without notice and without incurring obligations.

Book 2
Tab 4a

New

Book 3
Tab DE2

Pg 36

Catalog No. 520-927

Printed in U.S.A.

PC 111

Form 09D-3PD
Replaces: 09D-2PD

APPENDIX

F

CADNA OUTPUT



Receivers

Name	M.	ID	Level Lr		Limit. Value		Land Use			Height (m)	Coordinates			
			Day (dBA)	Night (dBA)	Day (dBA)	Night (dBA)	Type	Auto	Noise Type		X (m)	Y (m)	Z (m)	
R01		R01	39.6	-80.2	0.0	0.0				4.50	r	445585.62	5011951.14	95.50
R02		R02	39.3	-80.2	0.0	0.0				4.50	r	445590.16	5011922.62	95.53
R03		R03	43.6	-80.2	0.0	0.0				4.50	r	445674.80	5011882.53	96.13
R04		R04	46.7	-80.2	0.0	0.0				4.50	r	445704.59	5011886.45	96.31
R05		R05	46.7	-80.2	0.0	0.0				4.50	r	445755.43	5011891.85	96.62
R06		R06	46.7	-80.2	0.0	0.0				4.50	r	445783.52	5011894.66	96.81
R07		R07	47.2	-80.2	0.0	0.0				4.50	r	445827.90	5011954.64	97.54
R08		R08	47.3	-80.2	0.0	0.0				4.50	r	445827.63	5011961.04	97.63
R09		R09	44.4	-80.2	0.0	0.0				4.50	r	445823.88	5011997.13	98.12
R02_O		R02_O	40.0	-80.2	0.0	0.0				1.50	r	445597.88	5011922.32	92.59
R01_O		R01_O	39.3	-80.2	0.0	0.0				1.50	r	445595.63	5011951.20	92.52

Point Sources

Name	M.	ID	Result. PWL			Lw / Li		Correction			Sound Reduction		Attenuation	Operating Time			K0	Freq. (Hz)	Direct.	Height (m)	Coordinates		
			Day (dBA)	Evening (dBA)	Night (dBA)	Type	Value	norm. dB(A)	Day dB(A)	Evening dB(A)	Night dB(A)	R		Area (m²)	Day (min)	Special (min)					Night (min)	X (m)	Y (m)
RTU6 11T Condenser (2 fan)		SS RTU6c	83.8	83.8	83.8	Lw	COND RTU RN011		0.0	0.0	0.0			60.00	0.00	0.00	0.0	(none)	0.10	g	445768.78	5011956.41	101.00
RTU5 11T Condenser (2 fan)		SS RTU5c	83.8	83.8	83.8	Lw	COND RTU RN011		0.0	0.0	0.0			60.00	0.00	0.00	0.0	(none)	0.10	g	445752.22	5011944.48	101.00
RTU4 11T Condenser (2 fan)		SS RTU4c	83.8	83.8	83.8	Lw	COND RTU RN011		0.0	0.0	0.0			60.00	0.00	0.00	0.0	(none)	0.10	g	445767.27	5011976.19	101.00
RTU3 11T Condenser (2 fan)		SS RTU3c	83.8	83.8	83.8	Lw	COND RTU RN011		0.0	0.0	0.0			60.00	0.00	0.00	0.0	(none)	0.10	g	445738.70	5011961.68	101.00
RTU2 6T Condenser (1 fan)		SS RTU2c	80.8	80.8	80.8	Lw	COND RTU RN006		0.0	0.0	0.0			60.00	0.00	0.00	0.0	(none)	0.10	g	445706.25	5011945.51	101.00
RTU1 11T Condenser (2 fan)		SS RTU1c	83.8	83.8	83.8	Lw	COND RTU RN011		0.0	0.0	0.0			60.00	0.00	0.00	0.0	(none)	0.10	g	445725.18	5011944.54	101.00
Air Cooled VRF Condenser 2		SS CU1B	84.5	84.5	84.5	Lw	COND VRF	84.5	0.0	0.0	0.0			60.00	0.00	0.00	0.0	(none)	0.10	g	445733.32	5011943.95	101.59
Air Cooled VRF Condenser 1		SS CU1Ac	84.5	84.5	84.5	Lw	COND VRF	84.5	0.0	0.0	0.0			60.00	0.00	0.00	0.0	(none)	0.10	g	445734.90	5011943.99	101.59
RTU6 11T Exhaust Fan		SS RTU6e	91.6	91.6	91.6	Lw	EF RTU_6		0.0	0.0	0.0			60.00	0.00	0.00	0.0	(none)	0.60	g	445770.19	5011956.83	100.40
RTU5 11T Exhaust Fan		SS RTU5e	85.4	85.4	85.4	Lw	EF RTU REST		0.0	0.0	0.0			60.00	0.00	0.00	0.0	(none)	0.60	g	445750.96	5011943.92	100.40
RTU4 11T Exhaust Fan		SS RTU4e	85.4	85.4	85.4	Lw	EF RTU REST		0.0	0.0	0.0			60.00	0.00	0.00	0.0	(none)	0.60	g	445765.97	5011975.78	100.40
RTU3 11T Exhaust Fan		SS RTU3e	87.4	87.4	87.4	Lw	EF RTU_3		0.0	0.0	0.0			60.00	0.00	0.00	0.0	(none)	0.60	g	445737.78	5011961.53	100.40
RTU1 11T Exhaust Fan		SS RTU1e	85.4	85.4	85.4	Lw	EF RTU REST		0.0	0.0	0.0			60.00	0.00	0.00	0.0	(none)	0.60	g	445726.20	5011942.92	100.40
RTU2 6T Exhaust Fan		SS RTU2e	82.4	82.4	82.4	Lw	EF RTU_2		0.0	0.0	0.0			60.00	0.00	0.00	0.0	(none)	0.60	g	445706.82	5011944.35	100.40

Receiver
 Name: R08
 ID: R08
 X: 445827.63 m
 Y: 5011961.04 m
 Z: 97.63 m

Point Source, ISO 9613, Name: "RTU6 11T Exhaust Fan", ID: "SS_RTU6e"

Nr.	X (m)	Y (m)	Z (m)	Refl.	DEN	Freq. (Hz)	Lw dB(A)	l/a dB	Optime dB	K0 (dB)	Di (dB)	Adiv (dB)	Aatm (dB)	Agr (dB)	Afol (dB)	Ahous (dB)	Abar (dB)	Cmet (dB)	RL (dB)	Lr dB(/
21	445770.19	5011956.83	100.40	0	D	A	91.6	0.0	0.0	0.0	0.0	46.2	0.3	-3.0	0.0	0.0	4.8	0.0	0.0	43.
33	445770.19	5011956.83	100.40	1	D	A	91.6	0.0	0.0	0.0	0.0	46.4	0.3	-3.0	0.0	0.0	4.8	0.0	7.2	35.

Point Source, ISO 9613, Name: "RTU4 11T Exhaust Fan", ID: "SS_RTU4e"

Nr.	X (m)	Y (m)	Z (m)	Refl.	DEN	Freq. (Hz)	Lw dB(A)	l/a dB	Optime dB	K0 (dB)	Di (dB)	Adiv (dB)	Aatm (dB)	Agr (dB)	Afol (dB)	Ahous (dB)	Abar (dB)	Cmet (dB)	RL (dB)	Lr dB(/
43	445765.97	5011975.78	100.40	0	D	A	85.4	0.0	0.0	0.0	0.0	47.0	0.4	-3.0	0.0	0.0	10.4	0.0	0.0	30.

Point Source, ISO 9613, Name: "RTU6 11T Condenser (2 fan)", ID: "SS_RTU6c"

Nr.	X (m)	Y (m)	Z (m)	Refl.	DEN	Freq. (Hz)	Lw dB(A)	l/a dB	Optime dB	K0 (dB)	Di (dB)	Adiv (dB)	Aatm (dB)	Agr (dB)	Afol (dB)	Ahous (dB)	Abar (dB)	Cmet (dB)	RL (dB)	Lr dB(/
47	445768.78	5011956.41	101.00	0	D	A	83.8	0.0	0.0	0.0	0.0	46.4	0.4	-3.0	0.0	0.0	0.0	0.0	0.0	39.

Point Source, ISO 9613, Name: "RTU3 11T Exhaust Fan", ID: "SS_RTU3e"

Nr.	X (m)	Y (m)	Z (m)	Refl.	DEN	Freq. (Hz)	Lw dB(A)	l/a dB	Optime dB	K0 (dB)	Di (dB)	Adiv (dB)	Aatm (dB)	Agr (dB)	Afol (dB)	Ahous (dB)	Abar (dB)	Cmet (dB)	RL (dB)	Lr dB(/
70	445737.78	5011961.53	100.40	0	D	A	87.4	0.0	0.0	0.0	0.0	50.1	0.5	-3.0	0.0	0.0	15.5	0.0	0.0	24.

Point Source, ISO 9613, Name: "RTU4 11T Condenser (2 fan)", ID: "SS_RTU4c"

Nr.	X (m)	Y (m)	Z (m)	Refl.	DEN	Freq. (Hz)	Lw dB(A)	l/a dB	Optime dB	K0 (dB)	Di (dB)	Adiv (dB)	Aatm (dB)	Agr (dB)	Afol (dB)	Ahous (dB)	Abar (dB)	Cmet (dB)	RL (dB)	Lr dB(/
81	445767.27	5011976.19	101.00	0	D	A	83.8	0.0	0.0	0.0	0.0	46.9	0.4	-3.0	0.0	0.0	0.0	0.0	0.0	39.

Point Source, ISO 9613, Name: "RTU5 11T Exhaust Fan", ID: "SS_RTU5e"

Nr.	X (m)	Y (m)	Z (m)	Refl.	DEN	Freq. (Hz)	Lw dB(A)	l/a dB	Optime dB	K0 (dB)	Di (dB)	Adiv (dB)	Aatm (dB)	Agr (dB)	Afol (dB)	Ahous (dB)	Abar (dB)	Cmet (dB)	RL (dB)	Lr dB(/
93	445750.96	5011943.92	100.40	0	D	A	85.4	0.0	0.0	0.0	0.0	48.9	0.4	-3.0	0.0	0.0	13.0	0.0	0.0	26.

Point Source, ISO 9613, Name: "RTU5 11T Condenser (2 fan)", ID: "SS_RTU5c"

Nr.	X (m)	Y (m)	Z (m)	Refl.	DEN	Freq. (Hz)	Lw dB(A)	l/a dB	Optime dB	K0 (dB)	Di (dB)	Adiv (dB)	Aatm (dB)	Agr (dB)	Afol (dB)	Ahous (dB)	Abar (dB)	Cmet (dB)	RL (dB)	Lr dB(/
103	445752.22	5011944.48	101.00	0	D	A	83.8	0.0	0.0	0.0	0.0	48.8	0.5	-3.0	0.0	0.0	4.8	0.0	0.0	32.

Point Source, ISO 9613, Name: "RTU1 11T Exhaust Fan", ID: "SS_RTU1e"

Nr.	X (m)	Y (m)	Z (m)	Refl.	DEN	Freq. (Hz)	Lw dB(A)	l/a dB	Optime dB	K0 (dB)	Di (dB)	Adiv (dB)	Aatm (dB)	Agr (dB)	Afol (dB)	Ahous (dB)	Abar (dB)	Cmet (dB)	RL (dB)	Lr dB(/
106	445726.20	5011942.92	100.40	0	D	A	85.4	0.0	0.0	0.0	0.0	51.3	0.6	-3.0	0.0	0.0	15.5	0.0	0.0	21.

Point Source, ISO 9613, Name: "Air Cooled VRF Condenser 1", ID: "SS_CU1Ac"

Nr.	X (m)	Y (m)	Z (m)	Refl.	DEN	Freq. (Hz)	Lw dB(A)	l/a dB	Optime dB	K0 (dB)	Di (dB)	Adiv (dB)	Aatm (dB)	Agr (dB)	Afol (dB)	Ahous (dB)	Abar (dB)	Cmet (dB)	RL (dB)	Lr dB(/
111	445734.90	5011943.99	101.59	0	D	A	84.5	0.0	0.0	0.0	0.0	50.5	0.6	-3.0	0.0	0.0	4.8	0.0	0.0	31.

Point Source, ISO 9613, Name: "Air Cooled VRF Condenser 2", ID: "SS_CU1B"

Nr.	X (m)	Y (m)	Z (m)	Refl.	DEN	Freq. (Hz)	Lw dB(A)	l/a dB	Optime dB	K0 (dB)	Di (dB)	Adiv (dB)	Aatm (dB)	Agr (dB)	Afol (dB)	Ahous (dB)	Abar (dB)	Cmet (dB)	RL (dB)	Lr dB(/
116	445733.32	5011943.95	101.59	0	D	A	84.5	0.0	0.0	0.0	0.0	50.6	0.6	-3.0	0.0	0.0	4.8	0.0	0.0	31.

Point Source, ISO 9613, Name: "RTU3 11T Condenser (2 fan)", ID: "SS_RTU3c"

Nr.	X (m)	Y (m)	Z (m)	Refl.	DEN	Freq. (Hz)	Lw dB(A)	l/a dB	Optime dB	K0 (dB)	Di (dB)	Adiv (dB)	Aatm (dB)	Agr (dB)	Afol (dB)	Ahous (dB)	Abar (dB)	Cmet (dB)	RL (dB)	Lr dB(/
126	445738.70	5011961.68	101.00	0	D	A	83.8	0.0	0.0	0.0	0.0	50.0	0.6	-3.0	0.0	0.0	4.8	0.0	0.0	31.

Point Source, ISO 9613, Name: "RTU1 11T Condenser (2 fan)", ID: "SS_RTU1c"

Nr.	X (m)	Y (m)	Z (m)	Refl.	DEN	Freq. (Hz)	Lw dB(A)	l/a dB	Optime dB	K0 (dB)	Di (dB)	Adiv (dB)	Aatm (dB)	Agr (dB)	Afol (dB)	Ahous (dB)	Abar (dB)	Cmet (dB)	RL (dB)	Lr dB(/
136	445725.18	5011944.54	101.00	0	D	A	83.8	0.0	0.0	0.0	0.0	51.3	0.6	-3.0	0.0	0.0	4.9	0.0	0.0	30.

Point Source, ISO 9613, Name: "RTU2 6T Exhaust Fan", ID: "SS_RTU2e"																				
Nr.	X	Y	Z	Refl.	DEN	Freq.	Lw	l/a	Optime	K0	Di	Adiv	Aatm	Agr	Afol	Ahous	Abar	Cmet	RL	Lr
	(m)	(m)	(m)			(Hz)	dB(A)	dB	dB	(dB)	(dB)	(dB)	(dB)	(dB)	(dB)	(dB)	(dB)	(dB)	(dB)	dB(A)
141	445706.82	5011944.35	100.40	0	D	A	82.4	0.0	0.0	0.0	0.0	52.7	0.7	-3.0	0.0	0.0	15.8	0.0	0.0	16.

Point Source, ISO 9613, Name: "RTU2 6T Condenser (1 fan)", ID: "SS_RTU2c"																				
Nr.	X	Y	Z	Refl.	DEN	Freq.	Lw	l/a	Optime	K0	Di	Adiv	Aatm	Agr	Afol	Ahous	Abar	Cmet	RL	Lr
	(m)	(m)	(m)			(Hz)	dB(A)	dB	dB	(dB)	(dB)	(dB)	(dB)	(dB)	(dB)	(dB)	(dB)	(dB)	(dB)	dB(A)
149	445706.25	5011945.51	101.00	0	D	A	80.8	0.0	0.0	0.0	0.0	52.8	0.7	-3.0	0.0	0.0	4.9	0.0	0.0	25.