

# 150 Laurier Avenue West

## Transportation Impact Assessment

Step 1 Screening Report

Step 2 Scoping Report

Step 3 Forecasting Report

Step 4 Strategy Report

Prepared for:

Jadco Group  
345, boul. Samson, suite 100,  
Laval (Québec) Canada H7X 2Z7

Prepared by:



6 Plaza Court  
Ottawa, ON K2H 7W1

August 2022

PN: 2022-074

## Table of Contents

1	Screening.....	1
2	Existing and Planned Conditions.....	1
2.1	Proposed Development.....	1
2.2	Existing Conditions.....	3
2.2.1	Area Road Network.....	3
2.2.2	Existing Intersections.....	4
2.2.3	Existing Driveways.....	5
2.2.4	Cycling and Pedestrian Facilities.....	5
2.2.5	Existing Transit.....	8
2.2.6	Existing Area Traffic Management Measures.....	9
2.2.7	Existing Peak Hour Travel Demand.....	9
2.2.8	Collision Analysis.....	11
2.3	Planned Conditions.....	14
2.3.1	Changes to the Area Transportation Network.....	14
2.3.2	Other Study Area Developments.....	14
3	Study Area and Time Periods.....	15
3.1	Study Area.....	15
3.2	Time Periods.....	15
3.3	Horizon Years.....	15
4	Exemption Review.....	15
5	Development-Generated Travel Demand.....	16
5.1	Mode Shares.....	16
5.2	Trip Generation.....	16
5.3	Trip Distribution.....	18
5.4	Trip Assignment.....	18
6	Background Network Travel Demands.....	20
6.1	Transportation Network Plans.....	20
6.2	Background Growth.....	20
6.3	Other Developments.....	21
7	Demand Rationalization.....	21
7.1	2027 Future Background Operations.....	21
7.2	2032 Future Background Operations.....	23
7.3	2027 Future Total Operations.....	24
7.4	2032 Future Total Operations.....	26
7.5	Modal Share Sensitivity and Demand Rationalization Conclusions.....	27
8	Development Design.....	28
8.1	Design for Sustainable Modes.....	28
8.2	Circulation and Access.....	28
9	Parking.....	28
9.1	Parking Supply.....	28
10	Boundary Street Design.....	28
11	Access Intersections Design.....	28

11.1 Location and Design of Access..... 28

11.2 Intersection Control..... 29

11.3 Access Intersection Design ..... 29

    11.3.1 Future Access Intersection Operations ..... 29

    11.3.2 Access Intersection MMLOS ..... 29

    11.3.3 Recommended Design Elements..... 29

12 Transportation Demand Management ..... 29

    12.1 Context for TDM ..... 29

    12.2 Need and Opportunity..... 29

    12.3 TDM Program ..... 29

13 Transit..... 29

    13.1 Transit Priority ..... 30

14 Network Intersection Design..... 30

    14.1 Network Intersection Control..... 30

    14.2 Network Intersection Design..... 30

        14.2.1 2027 & 2032 Future Total Network Intersection Operations ..... 30

        14.2.2 Network Intersection MMLOS..... 30

        14.2.3 Recommended Design Elements..... 31

15 Summary of Improvements Indicated and Modifications Options..... 31

16 Conclusion ..... 33

## List of Figures

Figure 1: Area Context Plan.....1

Figure 2: Concept Plan.....2

Figure 3: Existing Driveways .....5

Figure 4: Study Area Pedestrian Facilities .....6

Figure 5: Study Area Cycling Facilities .....6

Figure 6: Existing Pedestrian Volumes .....7

Figure 7: Existing Cyclist Volumes .....7

Figure 8: Existing Study Area Transit Service.....8

Figure 9: Existing Study Area Transit Stops .....9

Figure 10: Existing Traffic Counts ..... 10

Figure 11: Representation of Study Area Collision Records..... 12

Figure 12: New Site Generation Auto Volumes..... 19

Figure 13: Pass-By Volumes..... 20

Figure 14: Background developments volumes ..... 21

Figure 15: 2027 Future Background Volumes ..... 22

Figure 16: 2032 Future Background Volumes ..... 23

Figure 17: 2027 Future Total Volumes ..... 25

Figure 18: 2032 Future Total Volumes ..... 26

## Table of Tables

Table 1: Intersection Count Date.....	9
Table 2: Existing Intersection Operations.....	10
Table 3: Study Area Collision Summary, 2016-2020 .....	11
Table 4: Summary of Collision Locations, 2016-2020.....	12
Table 5: Elgin Street at Laurier Avenue Collision Summary .....	13
Table 6: Metcalfe Street at Laurier Avenue Collision Summary.....	13
Table 7: Laurier Avenue West between Metcalfe Street and Elgin Street Collision Summary .....	14
Table 8: Exemption Review .....	15
Table 9: TRANS Trip Generation Manual Recommended Mode Shares – Ottawa Inner Area .....	16
Table 10: Proposed Development Mode Shares – Within 450 m of Rapid Transit.....	16
Table 11: Trip Generation Person Trip Rates by Peak Period.....	16
Table 12: Total Residential Person Trip Generation by Peak Period.....	17
Table 13: Internal Capture Rates.....	17
Table 14: Trip Generation by Mode .....	18
Table 15: OD Survey Distribution – Ottawa Inner .....	18
Table 16: Trip Assignment .....	19
Table 17: TRANS Regional Model Projections – Study Area Growth Rates.....	20
Table 18: Recommended Area Growth Rates .....	21
Table 19: 2027 Future Background Intersection Operations .....	22
Table 20: 2032 Future Background Intersection Operations .....	24
Table 21: 2027 Future Total Intersection Operations .....	25
Table 22: 2032 Future Total Intersection Operations .....	27
Table 23: Boundary Street MMLOS Analysis .....	28
Table 24: Trip Generation by Transit Mode .....	30
Table 25: Study Area Intersection MMLOS Analysis .....	30

## List of Appendices

Appendix A – TIA Screening Form and Certification Form
Appendix B – Turning Movement Count Data
Appendix C – Synchro Intersection Worksheets – Existing Conditions
Appendix D – Collision Data
Appendix E – City TRANS Plots
Appendix F – Background Development Volumes
Appendix G – Synchro Intersection Worksheets – 2027 Future Background Conditions
Appendix H – Synchro Intersection Worksheets – 2032 Future Background Conditions
Appendix I – Synchro Intersection Worksheets – 2027 Future Total Conditions
Appendix J – Synchro Intersection Worksheets – 2032 Future Total Conditions
Appendix K – Turning Templates
Appendix L – MMLOS Analysis
Appendix M – TDM Checklist

## 1 Screening

This study has been prepared according to the City of Ottawa's 2017 Transportation Impact Assessment (TIA) Guidelines. Accordingly, a Step 1 Screening Form has been prepared and is included as Appendix A, along with the Certification Form for the TIA Study PM. As shown in the Screening Form, a TIA is required including the Design Review component and the Network Impact Component. This study has been prepared to support a site plan application.

## 2 Existing and Planned Conditions

### 2.1 Proposed Development

The existing site, located at 150 Laurier Avenue West, is zoned as Mixed Use/Commercial Zone (MD S50). The proposed redevelopment will convert an existing 9-storey commercial/retail building to a 27-storey mixed-use building with ground floor commercial/retail and residential. In total, 312 residential units and 4,117 sq. ft. of commercial/retail will be provided with 200 auto parking spaces and 300 bike parking spaces. The existing surface and underground accesses on the east side will be removed, and an access located on the western limit of the site will remain. The anticipated build-out and occupancy horizon is assumed to be 2027 with construction occurring in a single phase. The site is located within the Central Area Secondary Plan area and Design Priority Area. Figure 1 illustrates the study area context. Figure 2 illustrates the proposed concept plan.

Figure 1: Area Context Plan



Source: <http://maps.ottawa.ca/geoOttawa/> Accessed: July 6, 2022

Figure 2: Concept Plan

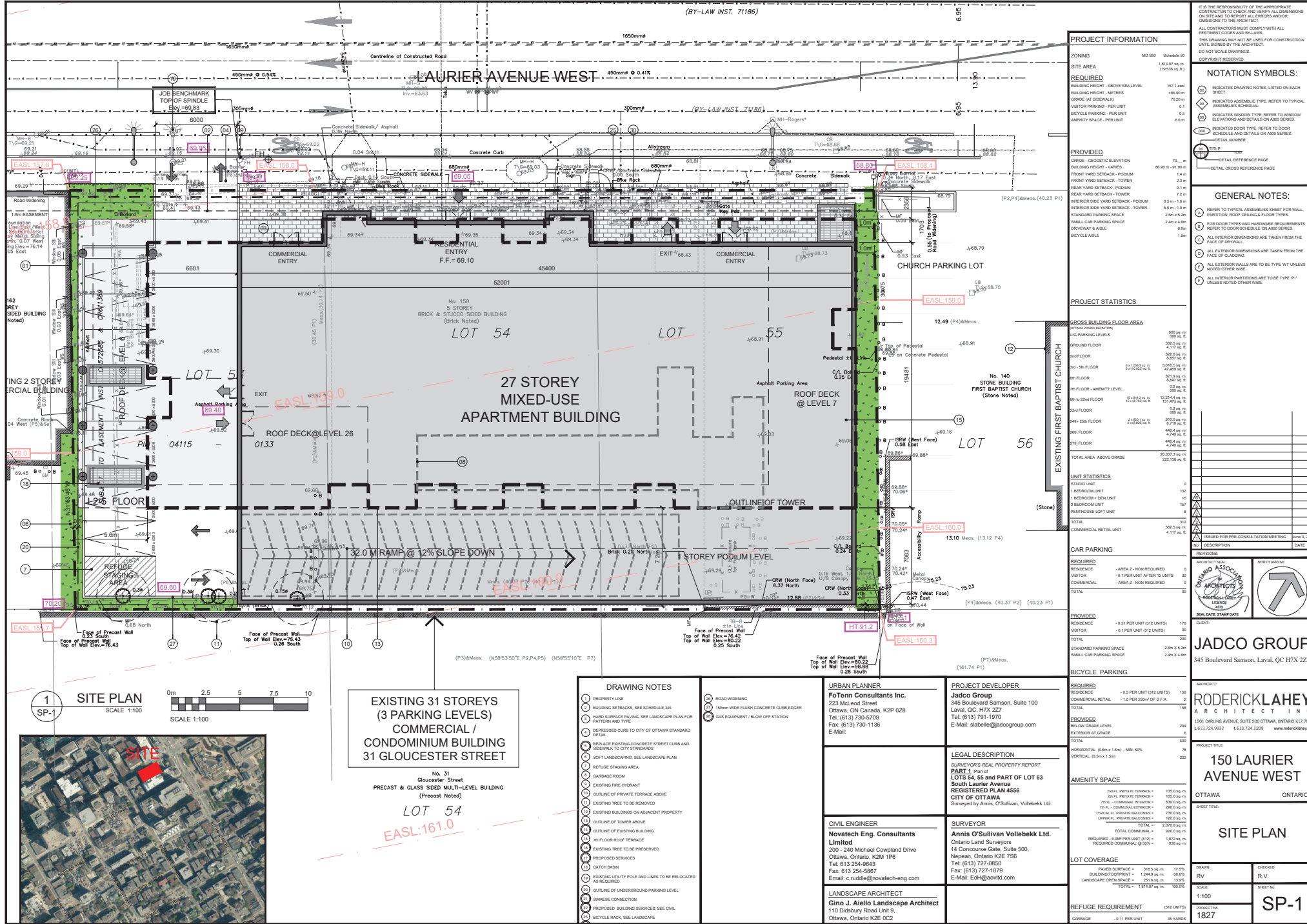

<b>PROJECT INFORMATION</b> ZONING: MD 550 Schedule 50 SITE AREA: 1,814.27 sq. m. (19,537 sq. ft.) <b>REQUIRED</b> BUILDING HEIGHT - ABOVE SEA LEVEL: 157.1 met BUILDING HEIGHT - METRES: 480.00 m GRADE OF SIDEWALK: 70.20 m VISITOR PARKING - PER UNIT: 0.1 BICYCLE PARKING - PER UNIT: 0.5 AMENITY SPACE - PER UNIT: 6.5 m <sup>2</sup>	
<b>PROVIDED</b> GRADE - GEODETIC ELEVATION: 70.1 m BUILDING HEIGHT - VARIES: 88.90 m - 117.00 m FRONT YARD SETBACK - PODIUM: 1.4 m FRONT YARD SETBACK - TOWER: 2.3 m REAR YARD SETBACK - PODIUM: 0.1 m REAR YARD SETBACK - TOWER: 7.2 m INTERIOR SIDE YARD SETBACK - PODIUM: 0.5 m - 1.0 m INTERIOR SIDE YARD SETBACK - TOWER: 5.6 m - 1.0 m STANDING PARKING SPACE: 2.8 m x 5.2 m SMALL CAR PARKING SPACE: 2.4 m x 4.8 m BICYCLE & AMBLE: 1.5 m DRIVEWAY: 6.0 m	
<b>NOTATION SYMBOLS:</b> (Symbol) INDICATES DRAWING NOTES LISTED ON EACH SHEET (Symbol) INDICATES ASSEMBLY TYPE. REFER TO TYPICAL ASSEMBLY SCHEDULE. (Symbol) INDICATES WINDOW TYPE. REFER TO WINDOW ELEVATIONS AND DETAILS ON ADD SERIES. (Symbol) INDICATES DOOR TYPE. REFER TO DOOR SCHEDULE AND DETAILS ON ADD SERIES. (Symbol) TITLE (Symbol) DETAIL REFERENCE PAGE (Symbol) DETAIL CROSS REFERENCE PAGE	
<b>GENERAL NOTES:</b> (1) REFER TO TYPICAL ASSEMBLY SHEET FOR WALL PARTITION, ROOF CEILING & FLOOR TYPE. (2) FOR DOOR TYPES AND HARDWARE REQUIREMENTS REFER TO DOOR SCHEDULE ON ADD SERIES. (3) ALL INTERIOR DIMENSIONS ARE TAKEN FROM THE FACE OF PARTIAL. (4) ALL EXTERIOR DIMENSIONS ARE TAKEN FROM THE FACE OF CURB. (5) ALL EXTERIOR WALLS ARE TO BE TYPE 'W' UNLESS NOTED OTHERWISE. (6) ALL INTERIOR PARTITIONS ARE TO BE TYPE 'P' UNLESS NOTED OTHERWISE.	
<b>PROJECT STATISTICS</b> GROSS BUILDING FLOOR AREA: GROUND FLOOR: 382.5 m <sup>2</sup> , 4,117 sq. ft. 2ND FLOOR: 822.8 m <sup>2</sup> , 8,857 sq. ft. 3rd - 5th FLOOR: 3,078.5 m <sup>2</sup> , 33,287 sq. ft. 6th FLOOR: 821.9 m <sup>2</sup> , 8,847 sq. ft. 7th FLOOR - AMENITY LEVEL: 0.0 m <sup>2</sup> , 0.0 sq. ft. 8th to 22nd FLOOR: 12,214.4 m <sup>2</sup> , 131,974 sq. ft. 23rd FLOOR: 0.0 m <sup>2</sup> , 0.0 sq. ft. 24th FLOOR: 810.0 m <sup>2</sup> , 8,719 sq. ft. 25th FLOOR: 448.0 m <sup>2</sup> , 4,780 sq. ft. 26th FLOOR: 448.0 m <sup>2</sup> , 4,780 sq. ft. TOTAL AREA ABOVE GRADE: 22,627.3 m <sup>2</sup> , 243,108 sq. ft.	
<b>UNIT STATISTICS</b> STUDIO UNIT: 0 1 BEDROOM UNIT: 132 1 BEDROOM + DEN UNIT: 15 2 BEDROOM UNIT: 187 PENTHOUSE LOFT UNIT: 1 TOTAL: 335 COMMERCIAL RETAIL UNIT: 382.5 m <sup>2</sup> , 4,117 sq. ft.	
<b>CAR PARKING</b> REQUIRED: RESIDENCE - AREA 2 - NON REQUIRED: 0 VISITOR - AREA 2 - NON REQUIRED: 0 COMMERCIAL - AREA 2 - NON REQUIRED: 0 TOTAL: 0 PROVIDED: RESIDENCE - 0.51 PER UNIT (212 UNITS): 110 VISITOR - 0.1 PER UNIT (112 UNITS): 30 TOTAL: 140 STANDARD PARKING SPACE: 2.8m x 5.2m SMALL CAR PARKING SPACE: 2.4m x 4.8m	
<b>BICYCLE PARKING</b> REQUIRED: RESIDENCE - 0.5 PER UNIT (212 UNITS): 106 COMMERCIAL RETAIL - 1.0 PER 200M <sup>2</sup> OF G.F.A.: 2 TOTAL: 108 PROVIDED: BELOW GRADE LEVEL: 294 EXTERIOR AT GRADE: 6 TOTAL: 300 HORIZONTAL: (0.9m x 1.8m) - MIN. 50% VERTICAL: (0.5m x 1.5m)	
<b>AMENITY SPACE</b> 7th FL. PRIVATE TERRACE: 155.0 m <sup>2</sup> , 1,667 sq. ft. 8th FL. PRIVATE TERRACE: 165.0 m <sup>2</sup> , 1,776 sq. ft. 7th FL. - COMM. EXTERIOR: 650.0 m <sup>2</sup> , 6,990 sq. ft. 7th FL. - COMM. EXTERIOR: 290.0 m <sup>2</sup> , 3,111 sq. ft. 7th FL. PRIVATE BALCONIES: 750.0 m <sup>2</sup> , 8,073 sq. ft. UPPER FL. PRIVATE BALCONIES: 120.0 m <sup>2</sup> , 1,290 sq. ft. TOTAL: 2,975.0 m <sup>2</sup> , 32,067 sq. ft. TOTAL COMM. AMENITY: 920.0 m <sup>2</sup> , 9,861 sq. ft. REQUIRED: 6.5M <sup>2</sup> PER UNIT (112) = 1,872 m <sup>2</sup> , 20,194 sq. ft. REQUIRED COMM. AMENITY: 920 m <sup>2</sup> , 9,861 sq. ft.	
<b>LOT COVERAGE</b> PAVED SURFACE: 314.5 m <sup>2</sup> , 3,387 sq. ft. 17.3% BUILDING FOOTPRINT: 1,248.9 m <sup>2</sup> , 13,469 sq. ft. 68.9% LANDSCAPE OPEN SPACE: 291.8 m <sup>2</sup> , 3,130 sq. ft. 15.8% TOTAL: 1,855.2 m <sup>2</sup> , 20,086 sq. ft. 103.0%	
<b>REFUGES REQUIREMENT</b> (112 UNITS) CARBAGE: -0.11 PER UNIT 33 YARDS	
<b>LEGAL DESCRIPTION</b> SURVEYOR'S REAL PROPERTY REPORT PART 1 Part of LOTS 54, 55 and PART OF LOT 53 South Laurier Avenue REGISTERED PLAN 4556 CITY OF OTTAWA Surveyed by Atris, O'Sullivan, Vollebek Ltd.	
<b>AMENITY SPACE</b> SURVEYOR: Annis O'Sullivan Vollebek Ltd. Ontario Land Surveyors 14 Concourse Gate, Suite 500, Nepean, Ontario K2E 7S6 Tel: (613) 727-6550 Fax: (613) 727-1079 E-Mail: EdH@aovill.com	
<b>LANDSCAPE ARCHITECT</b> Gino J. Aiello Landscape Architect 110 Didsbury Road Unit 9, Ottawa, Ontario K2E 0C2	
<b>PROJECT DEVELOPER</b> Jadco Group 345 Boulevard Samson, Suite 100 Laval, QC, H7X 2Z7 Tel: (613) 791-1970 Fax: (613) 730-1136 E-Mail: sisabelle@jadcogroup.com	
<b>URBAN PLANNER</b> FoTenn Consultants Inc. 223 McLeod Street Ottawa, ON Canada, K2P 0Z8 Tel: (613) 730-5709 Fax: (613) 730-1136 E-Mail:	
<b>CIVIL ENGINEER</b> Novatech Eng. Consultants Limited 200 - 240 Michael Cowland Drive Ottawa, Ontario, K2M 1P6 Tel: (613) 254-9543 Fax: (613) 254-5867 E-Mail: c.ruddle@novatech-eng.com	
<b>DRAWING NOTES</b> (1) PROPERTY LINE (2) BUILDING SETBACKS, SEE SCHEDULE 345 (3) HARD SURFACE PAVING, SEE LANDSCAPE PLAN FOR PATTERN AND TYPE (4) DEPRESSED CURBS TO CITY OF OTTAWA STANDARD DETAIL (5) REPLACE EXISTING CONCRETE STREET CURB AND SIDEWALK TO CITY STANDARD (6) SOFT LANDSCAPING, SEE LANDSCAPE PLAN (7) REFUGE STAGING AREA (8) GARAGE ROOM (9) EXISTING FIRE HYDRANT (10) OUTLINE OF PRIVATE TERRACE ABOVE (11) EXISTING TREE TO BE REMOVED (12) EXISTING BUILDINGS ON ADJACENT PROPERTY (13) OUTLINE OF TOWER ABOVE (14) OUTLINE OF EXISTING BUILDING (15) 7th FLOOR ROOF TERRACE (16) EXISTING TREE TO BE PRESERVED (17) PROPOSED SERVICES (18) CATCH BASIN (19) EXISTING UTILITY POLE AND LINES TO BE RELOCATED AS REQUIRED (20) OUTLINE OF UNDERGROUND PARKING LEVEL (21) SAMESE CONNECTION (22) PROPOSED BUILDING SERVICES, SEE CIVL (23) BICYCLE RACK, SEE LANDSCAPE	
<b>ROAD WIDENING</b> (1) 150mm WIDE FLUSH CONCRETE CURB EDGE (2) GAS EQUIPMENT / BLOW OFF STATION	
<b>EXISTING 31 STOREYS (3 PARKING LEVELS) COMMERCIAL / CONDOMINIUM BUILDING 31 GLOUCESTER STREET</b> No. 31 Gloucester Street PRECAST & GLASS SIDED MULTI-LEVEL BUILDING (Precast Notes) LOT 54 EASL:161.0	
<b>1 SITE PLAN</b> SCALE 1:100 0m 2.5 5 7.5 10 SCALE 1:100	

## 2.2 Existing Conditions

### 2.2.1 Area Road Network

*Laurier Avenue West:* Laurier Avenue West is a City of Ottawa arterial road with a three-lane cross-section, and a four-lane cross-section east of Elgin Street. Protected bike lanes are provided west of Elgin Street, with a cycle track on the south side of the road to the west of Elgin Street and an on-street bike lane on the north side. Sidewalks are present on both sides of the road. An unposted speed limit is assumed to be 50km/h. The city-protected right-of-way is 20.0 metres west of Elgin Street and 26.0 metres east of Elgin Street.

*O'Connor Street:* O'Connor Street is a City of Ottawa one-way arterial road (southbound) with a three-lane cross-section. A two-way protected bike lane is present on the east side of the road south of Laurier Avenue West, and a southbound transition is located to the north. Sidewalks are present on both sides of the road. Within the study area, paid parking is provided on the west side north of Slater Street for a maximum of one hour on weekdays from 9:00AM to 3:30PM. Between Slater Street and Laurier Avenue West, on-street parking is restricted on the west side during 9:00AM to 3:00PM, and paid parking is provided on the east side of the road from 8:00AM to 5:30PM for a maximum of one hour on weekdays. Between Laurier Avenue West and Gloucester Street, paid parking is provided on both sides of the road for a maximum of one hour on weekdays from 8:00AM to 3:30PM. South of Gloucester Street, paid parking is provided on the west side for a maximum of one hour on weekdays from 8:00AM to 5:30PM. An unposted speed limit is assumed to be 50km/h. The city-protected right-of-way is 20.0 metres within the study area.

*Metcalfe Street:* Metcalfe Street is a City of Ottawa one-way arterial road (northbound) with a three-lane cross-section. Sidewalks are present on both sides of the road. Within the study area, paid parking was provided on the west side of the road between Slater Street and Laurier Avenue West for a maximum of one hour on weekdays from 9:00AM to 3:30PM and on-street parking is restricted on the east side during 9:00AM to 3:30PM. South of Laurier Avenue West, paid parking was provided on the east side of the road for a maximum of one hour on weekdays from 8:00AM to 5:00PM. No parking is allowed along Metcalfe Street within the study area due to the temporary restrictions in the area for construction. An unposted speed limit is assumed to be 50km/h. The city-protected right-of-way is 20.0 metres within the study area.

*Elgin Street:* Elgin Street is a City of Ottawa arterial road with a divided four-lane cross-section. Sidewalks are present on both sides of the road. Within the study area, paid parking is provided from 7:00AM to 7:00PM for a maximum of two hours on the east side of the road between Gloucester Street and Lisgar Street and on both sides of the road south of Lisgar Street. An unposted speed limit is assumed to be 50km/h. The city-protected right-of-way is 40.0 metres within the study area.

*Gloucester Street:* Gloucester Street is a City of Ottawa one-way local road (westbound) with a two-lane cross-section. Within the study area, paid parking is permitted on the north side and partially on the south side of the road for two hours during weekdays from 7:00AM to 7:00PM west of Metcalfe Street, and for one hour during weekdays from 7:00AM to 7:00PM between Metcalfe Street and O'Connor Street, and permitted for two hours during weekdays from 7:00AM to 7:00PM on both sides of the road east of O'Connor Street. An unposted speed limit is assumed to be 50km/h. The measured right-of-way is 18.0-20.5 metres within the study area.

*Nepean Street:* Nepean Street is a City of Ottawa one-way local road (eastbound) with a two-lane cross-section. Sidewalks are present on both sides of the road. Within the study area, paid parking is provided on the south side of the road east of Metcalfe Street and was provided on both sides of the road west of Metcalfe Street. Due to the temporary restrictions in the area for construction, parking is restricted along Nepean Street between

Metcalf Street and O'Connor Street. An unposted speed limit is assumed to be 50km/h. The measured right-of-way is 18.0-20.5 metres within the study area.

### 2.2.2 Existing Intersections

The existing signalized area key intersections within 400 metres of the site have been summarized below:

*Laurier Avenue West at O'Connor Street* The intersection of Laurier Avenue West at O'Connor Street is a signalized intersection. The southbound approach consists of a protected bike lane, a shared left-turn/through lane, a through lane, and a shared through/right-turn lane, and the south leg of the intersection is inbound only with a bi-directional protected bike facility. The eastbound approach consists of a shared through/right-turn lane and a protected bike lane, and westbound approach consists of an auxiliary left-turn lane, a through lane and a protected bike lane. Right-turn on red is restricted on the southbound and eastbound movements. Bike boxes are provided on the north, south, and east legs.

*Laurier Avenue West at Metcalfe Street* The intersection of Laurier Avenue West at Metcalfe Street is a signalized intersection. The northbound approach consists of a shared left-turn/through lane, a through lane, and a shared through/right-turn lane, and the north leg of the intersection is inbound only. The eastbound approach consists of a shared left-turn/through lane and a protected bike lane, and westbound approach consists of an auxiliary through lane, a shared through/right-turn lane, and a protected bike lane. Right-turn on red is restricted on the northbound and westbound movements. Westbound left-turn movement is restricted during 7:00 to 9:00AM and 3:30 to 5:30PM on weekdays. Bike box is provided on the south leg.

*Laurier Avenue West at Elgin Street* The intersection of Laurier Avenue West at Elgin Street is a signalized intersection. The northbound approach consists of two through lanes and an auxiliary right-turn lane, and the southbound approach consists of two auxiliary left-turn lane, a through lane, and a shared through/right-turn lane. The eastbound approach consists of an auxiliary through lane, a shared through/right-turn lane, and a protected bike lane, and the westbound approach consists of a left-turn lane, a through lane, a protected bike lane, and an auxiliary right-turn lane. Northbound left-turn, eastbound left-turn, and eastbound right-turn on red are restricted. Bike box is provided on the west leg.

*Gloucester Street at Metcalfe Street* The intersection of Gloucester Street at Metcalfe Street is a signalized intersection. The northbound approach consists of a shared left-turn/through lane and two through lanes, and the westbound approach consists of a shared left-turn/through lane and a through lane. The north and west legs of the intersection are inbound only.

*Nepean Street at Elgin Street* The intersection of Nepean Street at Elgin Street is a signalized intersection. The northbound approach consists of a through lane and an a shared through/right-turn lane, and the southbound approach consists of an auxiliary left-turn lane and two through lanes. The



eastbound approach consists of a shared all-movement lane, and the westbound approach consists of a left-turn and a right-turn lane. The west leg provide access to the underground parking lot at City Hall.

### 2.2.3 Existing Driveways

Within 200 metres of the proposed site access, a couple of driveways to underground parking and surface parking are present along Laurier Avenue West. Along Laurier Avenue West there are driveways to the First Baptist Church, two to private loading zones, the Ottawa Courthouse, and City Hall. Along Elgin Street, two driveways to a hotel are present on the west side of Elgin Street, and a driveway to the Ottawa Courthouse is present on the east side of Elgin Street. Driveways to underground parking are also present along Metcalfe Street. Figure 3 illustrates the existing driveways.

Figure 3: Existing Driveways

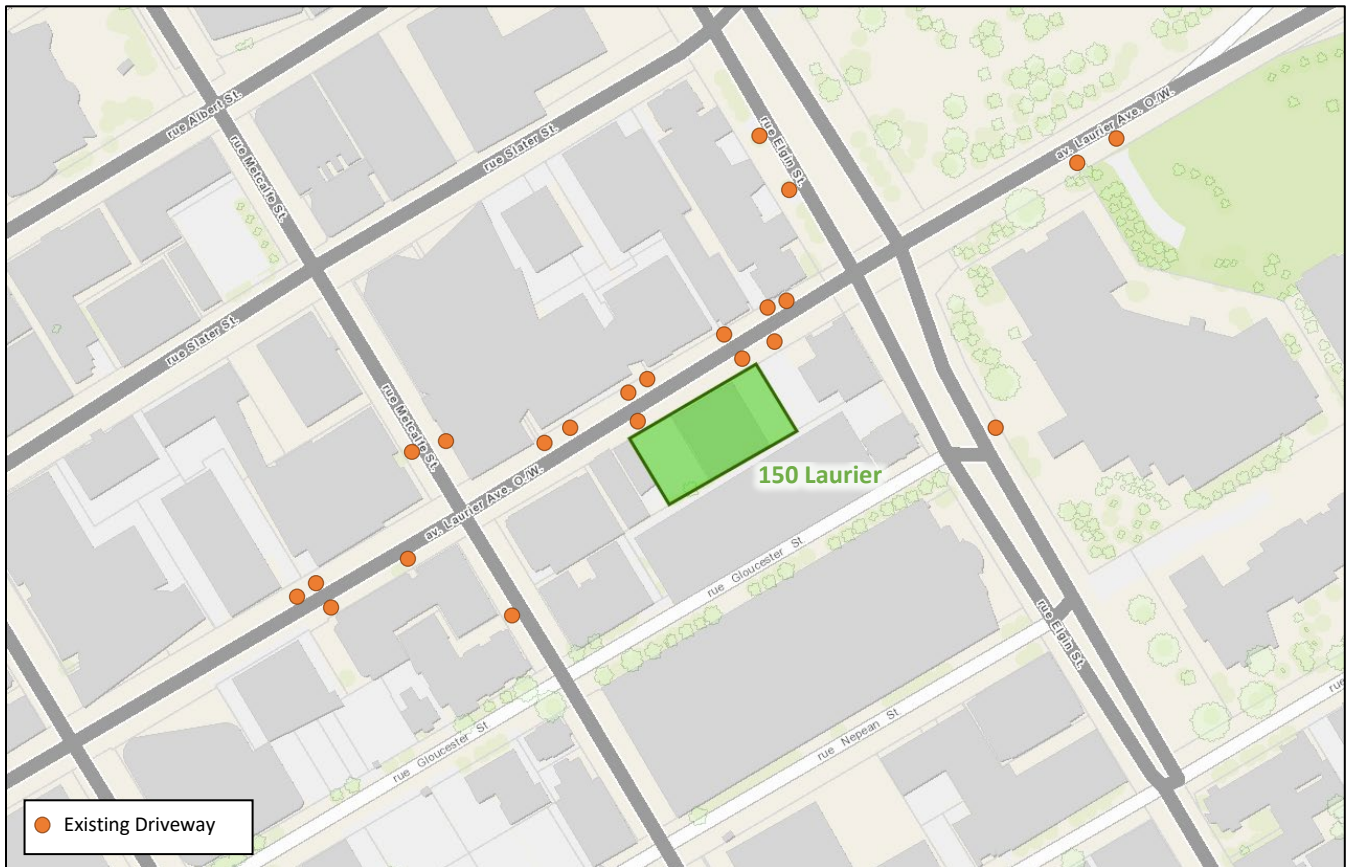

### 2.2.4 Cycling and Pedestrian Facilities

Figure 4 illustrates the pedestrian facilities in the study area and Figure 5 illustrates the cycling facilities.

Sidewalks are provided on both sides along all roads within the study area.

Cycling facilities include protected bikes lanes on both sides along Laurier Avenue West west of Elgin Street, a two-way protected bikes lane on the east side of O’Connor Street south of Laurier Avenue West, and a southbound transition is located to the north. Cycle track is provided on the south side and on-street bike lane is provided on the north side along Laurier Avenue West east of Elgin Street. Elgin Street is a suggested route.

Laurier Avenue West, Metcalfe Street, O'Connor Street, and Elgin Street north of Laurier Avenue West are spine routes and Elgin Street south of Laurier Avenue West is a local route. Elgin Street north of Laurier Avenue West, Laurier Avenue West, and O'Connor Street are cross-town bikeways.

Figure 4: Study Area Pedestrian Facilities

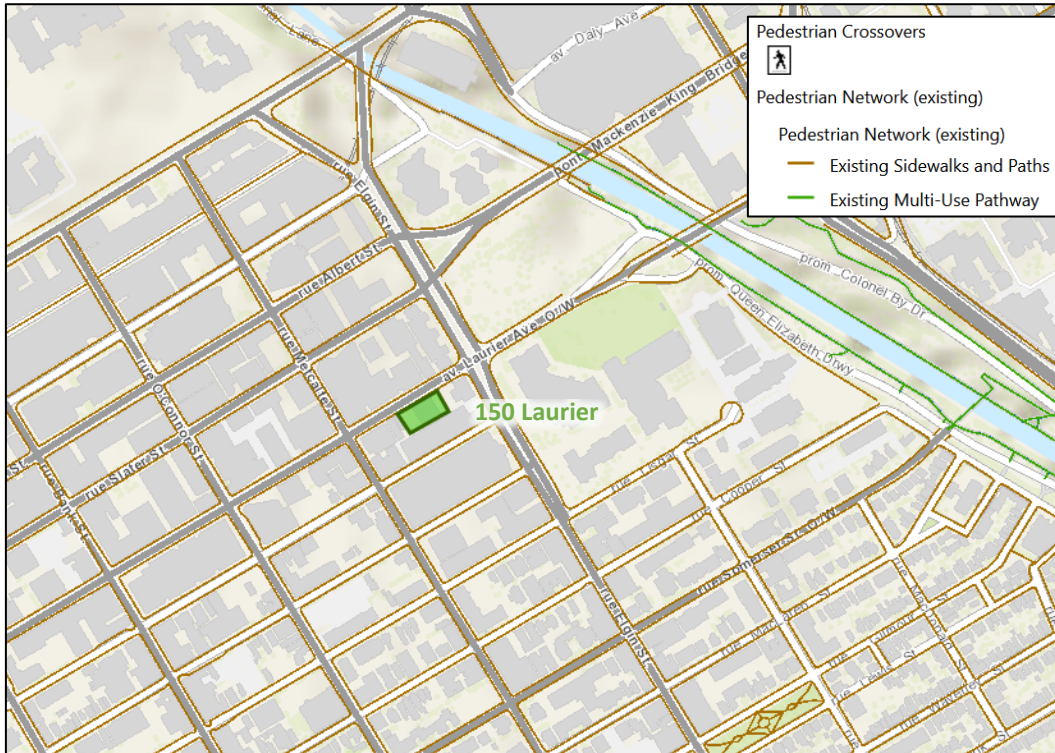

Source: <http://maps.ottawa.ca/geoOttawa/> Accessed: July 6, 2022

Figure 5: Study Area Cycling Facilities

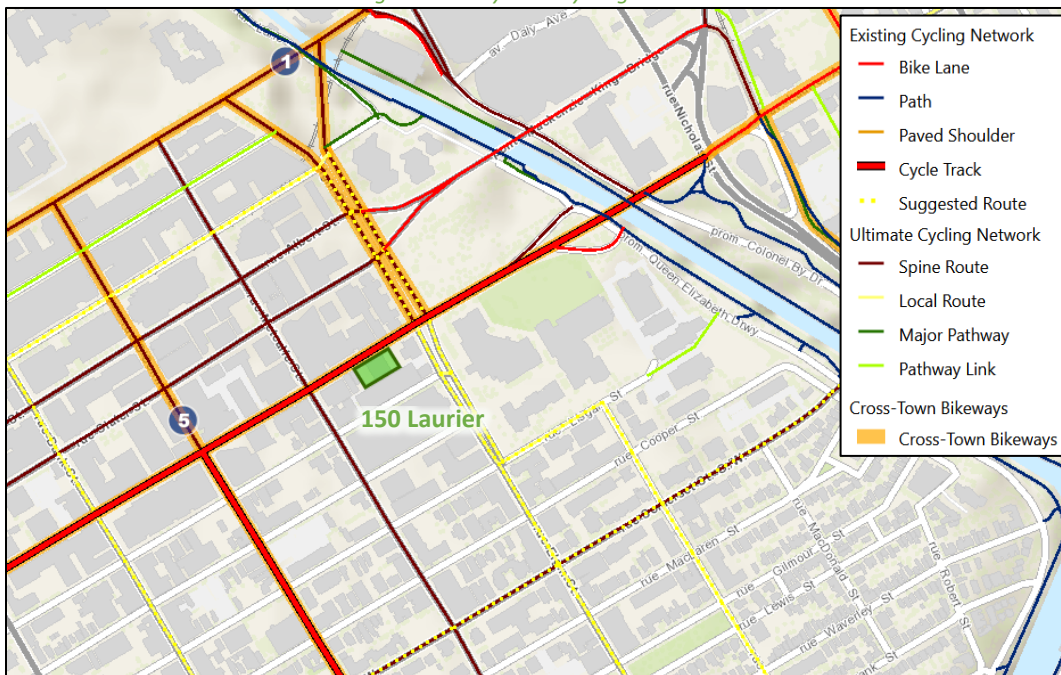

Source: <http://maps.ottawa.ca/geoOttawa/> Accessed: July 6, 2022

Pedestrian and cyclist volumes included in study area intersection counts, presented in Section 2.2.7, have been compiled and are illustrated in Figure 6 and Figure 7, respectively.

Figure 6: Existing Pedestrian Volumes

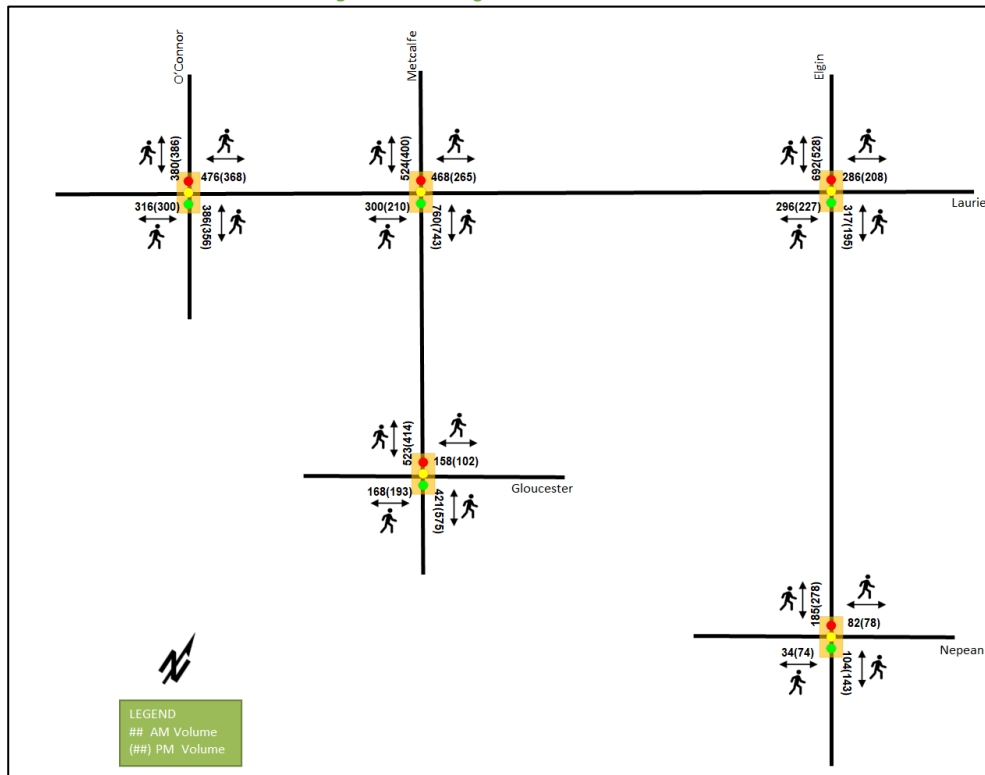
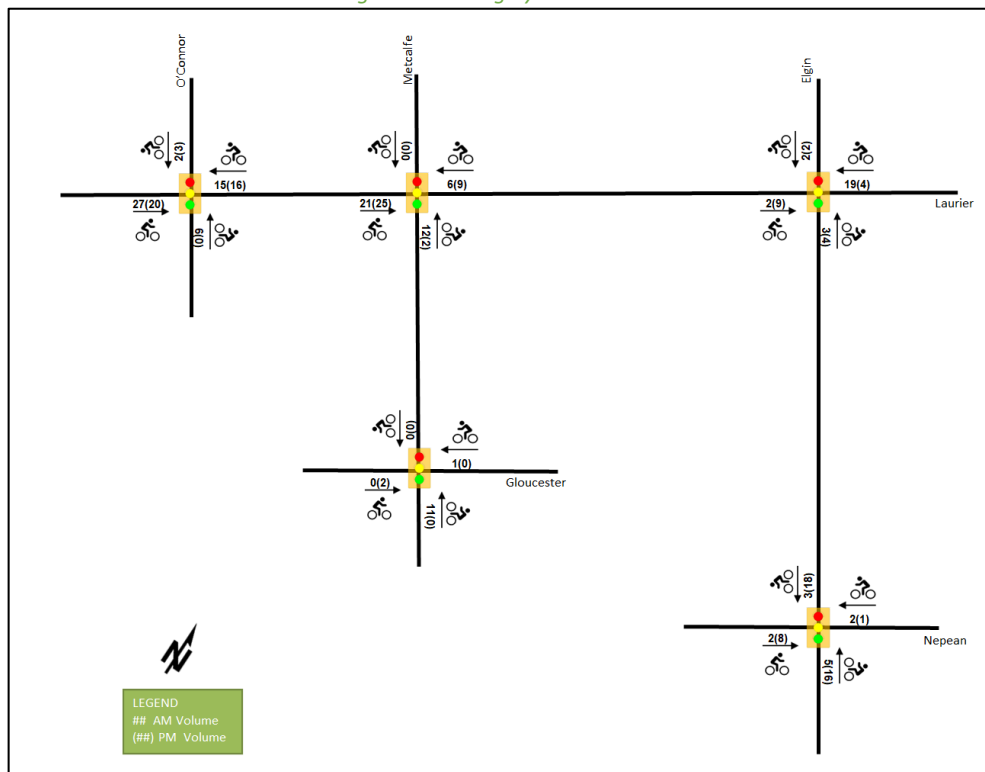

Figure 7: Existing Cyclist Volumes



2.2.5 Existing Transit

Within the study area, routes #5 and #14 travel along Elgin Street. The primary stop is located at the intersections of Elgin Street at Nepean Street. The frequency of these routes within proximity of the proposed site currently are:

- Route # 5 – 30-minute service all-day
- Route # 14 – 10-15-minute service all day, 30-minute service after 8:00 PM

Additionally, stops at the intersection of Slater Street and Metcalfe Street, which is within 300-metre walking distance from the site, provides service to transit routes #16 and #19, and stop at the intersection of Bank Street and Gloucester Street, which is within 550-metre walking distance from the site, provides service to transit routes #6, #7, and #11. Parliament LRT station is located within 650-metre walking distance, and it provides 5-minute service in the peak hours, 10-15 minute all-day.

Figure 8 illustrates the transit system map in the study area and Figure 9 illustrates nearby transit stops.

Figure 8: Existing Study Area Transit Service

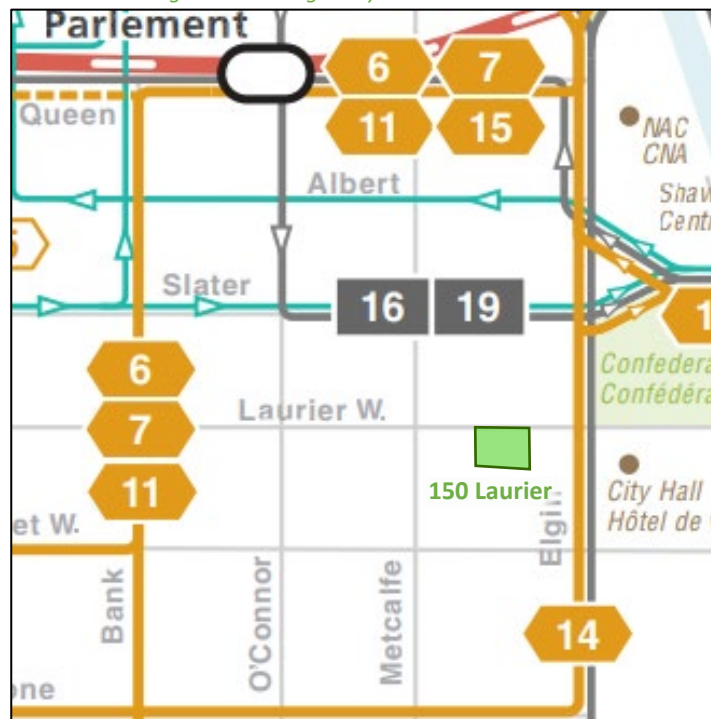

Source: <http://www.octranspo.com/> Accessed: July 6, 2022

Figure 9: Existing Study Area Transit Stops



Source: <http://www.octranspo.com/> Accessed: July 6, 2022

### 2.2.6 Existing Area Traffic Management Measures

There are no existing area traffic management measures within the study area.

### 2.2.7 Existing Peak Hour Travel Demand

Existing turning movement counts were acquired from the City of Ottawa and the Traffic Specialist for the existing study area intersections, and the volumes were balanced along the roadway corridors. Table 1 summarizes the intersection count dates and sources.

Table 1: Intersection Count Date

Intersection	Count Date	Source
Laurier Avenue West at O'Connor Street	Tuesday, March 21, 2017	City of Ottawa
Laurier Avenue West at Metcalfe Street	Tuesday, April 04, 2017	City of Ottawa
Laurier Avenue West at Elgin Street	Wednesday, February 27, 2019	City of Ottawa
Gloucester Street at Metcalfe Street	Tuesday, April 04, 2017	City of Ottawa
Nepean Street at Elgin Street	Tuesday, July 12, 2022	The Traffic Specialist

Figure 10 illustrates the existing traffic counts and volumes were balanced along Laurier Avenue West and Elgin Street. Table 2 summarizes the existing intersection operations. The level of service for signalized intersections is based on volume to capacity ratio (v/c) calculations for individual lane movements and HCM 2000 v/c calculations for the overall intersection, and average delay for unsignalized intersections. Detailed turning movement count data is included in Appendix B and the Synchro worksheets are provided in Appendix C.

Figure 10: Existing Traffic Counts

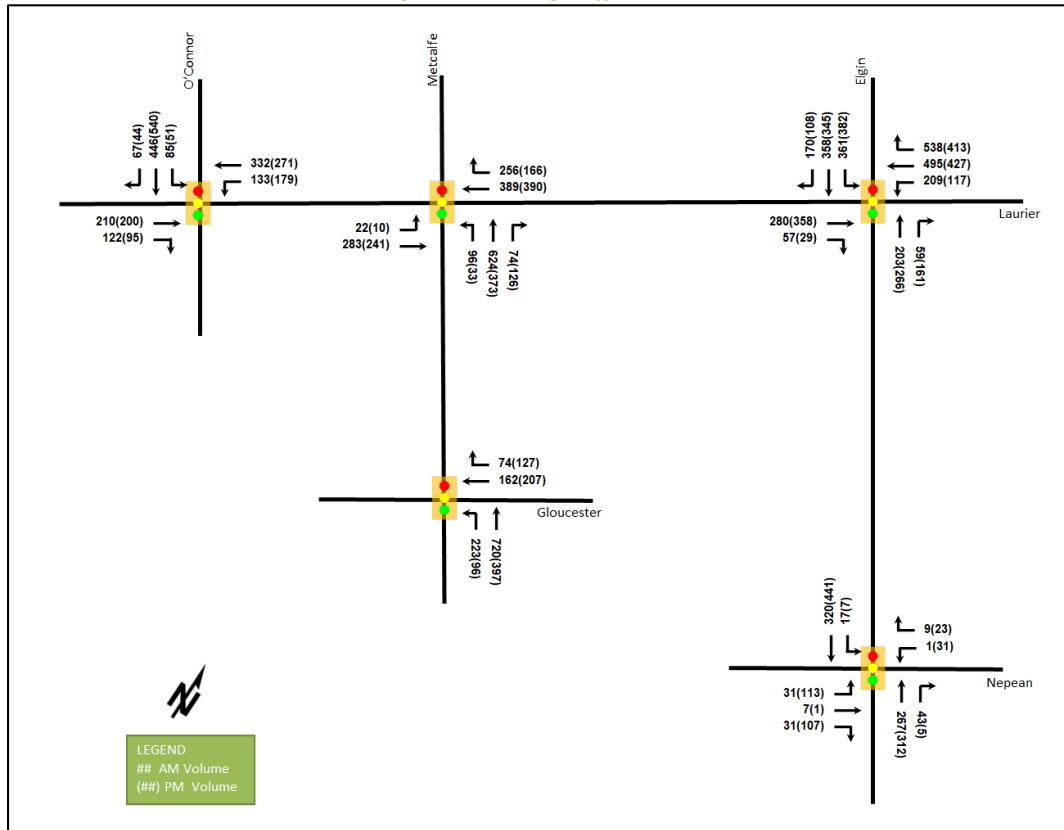

Table 2: Existing Intersection Operations

Intersection	Lane	AM Peak Hour				PM Peak Hour			
		LOS	V/C	Delay (s)	Q (95 <sup>th</sup> )	LOS	V/C	Delay (s)	Q (95 <sup>th</sup> )
Laurier Avenue West at O'Connor Street <i>Signalized</i>	EBT/R	B	0.69	28.0	72.7	A	0.60	24.4	61.8
	WBL	A	0.38	7.6	m9.9	A	0.47	21.7	37.0
	WBT	A	0.41	6.9	21.6	A	0.33	16.2	46.4
	SB	A	0.55	23.0	38.8	A	0.52	22.4	40.1
	<b>Overall</b>	<b>B</b>	<b>0.68</b>	<b>18.9</b>	-	<b>B</b>	<b>0.61</b>	<b>21.5</b>	-
Laurier Avenue West at Metcalfe Street <i>Signalized</i>	EBL/T	A	0.44	20.1	m61.4	A	0.32	6.7	13.6
	WBT/R	A	0.59	16.5	52.7	A	0.42	12.0	37.5
	NB	A	0.59	16.1	49.9	A	0.50	18.2	21.2
	<b>Overall</b>	<b>B</b>	<b>0.61</b>	<b>17.0</b>	-	<b>A</b>	<b>0.46</b>	<b>13.5</b>	-
Laurier Avenue West at Elgin Street <i>Signalized</i>	EBT/R	A	0.42	30.6	44.1	A	0.46	31.1	50.3
	WBL	B	0.67	31.4	45.9	A	0.42	23.0	27.2
	WBT	B	0.64	23.3	112.0	A	0.57	21.9	93.4
	WBR	<b>F</b>	<b>1.01</b>	<b>57.3</b>	<b>#116.6</b>	C	0.76	21.2	<b>#58.1</b>
	NBT	A	0.31	34.0	30.0	A	0.41	25.1	23.0
	NBR	A	0.18	1.1	0.0	A	0.51	8.4	8.7
	SBL	E	0.97	<b>82.1</b>	<b>#69.4</b>	E	0.95	76.6	<b>#71.4</b>
	SBT/R	A	0.54	19.6	52.0	A	0.43	18.6	43.9
<b>Overall</b>	<b>E</b>	<b>0.92</b>	<b>38.9</b>	-	<b>C</b>	<b>0.74</b>	<b>30.1</b>	-	

Intersection	Lane	AM Peak Hour				PM Peak Hour			
		LOS	V/C	Delay (s)	Q (95 <sup>th</sup> )	LOS	V/C	Delay (s)	Q (95 <sup>th</sup> )
<b>Gloucester Street at Metcalfe Street</b> <i>Signalized</i>	WBT/R	A	0.34	21.3	23.5	A	0.38	19.5	30.5
	NBL/T	A	0.40	7.7	30.8	A	0.23	7.9	16.8
	<b>Overall</b>	<b>A</b>	<b>0.37</b>	<b>10.5</b>	-	<b>A</b>	<b>0.27</b>	<b>12.6</b>	-
<b>Nepean Street at Elgin Street</b> <i>Signalized</i>	EB	A	0.17	16.1	15.5	A	0.38	16.5	42.7
	WBL	A	0.00	23.0	1.3	A	0.08	17.1	9.6
	WBR	A	0.02	0.1	0.0	A	0.04	2.0	2.2
	NBT/R	A	0.19	8.1	18.4	A	0.26	17.8	31.4
	SBL	A	0.04	8.3	4.1	A	0.02	14.1	m1.3
	SBT	A	0.19	9.0	20.4	A	0.33	18.3	46.2
	<b>Overall</b>	<b>A</b>	<b>0.17</b>	<b>9.2</b>	-	<b>A</b>	<b>0.35</b>	<b>17.3</b>	-

Notes: Saturation flow rate of 1800 veh/h/lane  
Queue is measured in metres  
Peak Hour Factor = 0.90

m = metered queue  
# = volume for the 95th %ile cycle exceeds capacity

During both peak hours, intersections within the study area operate well except for the Laurier Avenue West and Elgin Street intersection.

At the intersection of Laurier Avenue West and Elgin Street, during the AM peak, the westbound right-turn movement is over theoretical capacity and may be subject to extended queues, and the southbound left-turn movement may be subject to high delays and extended queues. During the PM peak, the westbound right-turn and southbound left-turn movements may exhibit extended queues.

### 2.2.8 Collision Analysis

Collision data have been acquired from the City of Ottawa open data website (data.ottawa.ca) for five years prior to the commencement of this TIA for the surrounding study area road network. Table 3 summarizes the collision types and conditions in the study area, Table 3 illustrates the intersections and segments analyzed, and Table 4 summarizes the total collisions for each of these locations. Collision data are included in Appendix D.

Table 3: Study Area Collision Summary, 2016-2020

Total Collisions		Number	%
		<b>114</b>	<b>100%</b>
<b>Classification</b>	<b>Fatality</b>	0	0%
	<b>Non-Fatal Injury</b>	23	20%
	<b>Property Damage Only</b>	91	80%
<b>Initial Impact Type</b>	<b>Angle</b>	9	8%
	<b>Rear end</b>	24	21%
	<b>Sideswipe</b>	34	30%
	<b>Turning Movement</b>	26	23%
	<b>SMV Unattended</b>	9	8%
	<b>SMV Other</b>	8	7%
	<b>Other</b>	4	4%
<b>Road Surface Condition</b>	<b>Dry</b>	83	73%
	<b>Wet</b>	16	14%
	<b>Loose Snow</b>	5	4%
	<b>Slush</b>	7	6%
	<b>Packed Snow</b>	1	1%
	<b>Ice</b>	2	2%
<b>Pedestrian Involved</b>		3	3%
<b>Cyclists Involved</b>		18	16%

Figure 11: Representation of Study Area Collision Records



Table 4: Summary of Collision Locations, 2016-2020

Intersections / Segments	Number	%
<b>Elgin St @ Laurier Ave</b>	<b>69</b>	<b>61%</b>
<b>Metcalfe St @ Laurier Ave</b>	<b>27</b>	<b>24%</b>
<b>Laurier Ave W btwn Metcalfe St &amp; Elgin St</b>	<b>17</b>	<b>15%</b>
<b>Laurier Ave W btwn Elgin St &amp; Elgin St</b>	<b>1</b>	<b>1%</b>

Within the study area, the intersection of Elgin Street at Laurier Avenue, Metcalfe Street at Laurier Avenue and segments of Laurier Avenue West between Metcalfe Street and Elgin Street are noted to have experienced higher collisions than other locations. Table 5, Table 6, and Table 7 summarize the collision types and conditions for each location.



Table 5: Elgin Street at Laurier Avenue Collision Summary

		Number	%
<b>Total Collisions</b>		<b>69</b>	<b>100%</b>
<b>Classification</b>	<b>Fatality</b>	0	0%
	<b>Non-Fatal Injury</b>	15	22%
	<b>Property Damage Only</b>	54	78%
<b>Initial Impact Type</b>	<b>Angle</b>	2	3%
	<b>Rear end</b>	15	22%
	<b>Sideswipe</b>	24	35%
	<b>Turning Movement</b>	17	25%
	<b>SMV Unattended</b>	1	1%
	<b>SMV Other</b>	7	10%
	<b>Other</b>	3	4%
<b>Road Surface Condition</b>	<b>Dry</b>	48	70%
	<b>Wet</b>	10	14%
	<b>Loose Snow</b>	5	7%
	<b>Slush</b>	5	7%
	<b>Unknown</b>	1	1%
<b>Pedestrian Involved</b>		3	4%
<b>Cyclists Involved</b>		11	16%

The Elgin Street at Laurier Avenue intersection had a total of 69 collisions during the 2016-2020 time period, with 54 involving property damage only and the remaining 15 having non-fatal injuries. The collision types are most represented by sideswipe with 24 collisions, followed by 17 turning movement collisions and 15 rear end collisions. General congestion and the skew of the through movements crossing the intersection may be contributing factors to the sideswipe collisions. It is also noted that this period included the Elgin construction activities and various detours. The varying types of cycling facilities on each leg are considered a direct contributor to the cycling collision frequency noted at this intersection. Weather conditions do not affect collisions at this location. No further analysis is required as part of this study.

Table 6: Metcalfe Street at Laurier Avenue Collision Summary

		Number	%
<b>Total Collisions</b>		<b>27</b>	<b>100%</b>
<b>Classification</b>	<b>Fatality</b>	0	0%
	<b>Non-Fatal Injury</b>	3	11%
	<b>Property Damage Only</b>	24	89%
<b>Initial Impact Type</b>	<b>Angle</b>	5	19%
	<b>Rear end</b>	7	26%
	<b>Sideswipe</b>	8	30%
	<b>Turning Movement</b>	3	11%
	<b>SMV Unattended</b>	2	7%
	<b>SMV Other</b>	1	4%
	<b>Other</b>	1	4%
<b>Road Surface Condition</b>	<b>Dry</b>	19	70%
	<b>Wet</b>	4	15%
	<b>Slush</b>	2	7%
	<b>Packed Snow</b>	1	4%
	<b>Ice</b>	1	4%
<b>Pedestrian Involved</b>		0	0%
<b>Cyclists Involved</b>		2	7%

The Metcalfe Street at Laurier Avenue intersection had a total of 27 collisions during the 2016-2020 time period, with 24 involving property damage only and the remaining three having non-fatal injuries. The collision types are most represented by sideswipe with eight collisions, followed by seven rear end collisions and five angle collisions. The collisions are distributed across the various types and no overall pattern is noted. Weather conditions do not affect collisions at this location. No further analysis is required as part of this study.

*Table 7: Laurier Avenue West between Metcalfe Street and Elgin Street Collision Summary*

<b>Total Collisions</b>		<b>Number</b>	<b>%</b>
		<b>17</b>	<b>100%</b>
<b>Classification</b>	<b>Fatality</b>	0	0%
	<b>Non-Fatal Injury</b>	5	29%
	<b>Property Damage Only</b>	12	71%
<b>Initial Impact Type</b>	<b>Angle</b>	2	12%
	<b>Rear end</b>	2	12%
	<b>Sideswipe</b>	2	12%
	<b>Turning Movement</b>	5	29%
	<b>SMV Unattended</b>	6	35%
<b>Road Surface Condition</b>	<b>Dry</b>	16	94%
	<b>Wet</b>	1	6%
<b>Pedestrian Involved</b>		0	0%
<b>Cyclists Involved</b>		5	29%

The segment of Laurier Avenue West between Metcalfe Street and Elgin Street had a total of 17 collisions during the 2016-2020 time period, with twelve involving property damage only and the remaining five having non-fatal injuries. The collision types are most represented by SMV Unattended with six collisions, followed by five turning movement collisions, with the remaining collisions split between angle, rear end, and sideswipe collision types. The collisions are distributed across the various types and no overall pattern is noted. Weather conditions do not affect collisions at this location. No further analysis is required as part of this study.

## 2.3 Planned Conditions

### 2.3.1 Changes to the Area Transportation Network

Within the Transportation Master Plan (TMP), the Rapid Transit and Transit Priority (RTTP) Network's Network Concept diagram shows an isolated measures transit priority corridor along Elgin Street between Gladstone Avenue and Wellington Street.

### 2.3.2 Other Study Area Developments

#### *208-212 Slater Street*

The proposed development application includes a site plan application for a mixed-use building containing either 180 apartment units and 1,000 ft<sup>2</sup> of retail GFA or 220 hotel units and approximately 1,000 ft<sup>2</sup> of retail GFA. To provide a conservative analysis, the hotel scenario has been carried forward for the intersection analysis in the report. The development built-out year is assumed to be 2022 and is predicted to generate 30 new AM and 27 new PM two-way peak hour auto trips. (Novatech, 2021)

#### *180 Metcalfe Street*

The proposed development application includes a site plan application for a 27-storey building with 311 apartment units. The development built-out year is assumed to be 2022/2023 and is predicted to generate 6 new AM and 26 new PM two-way peak hour auto trips. (Parsons, 2018)

### 3 Study Area and Time Periods

#### 3.1 Study Area

The study area will include the intersections of:

- Laurier Avenue West at:
  - O’Connor Street
  - Metcalfe Street
  - Elgin Street
  - Site Access (Future)
- Gloucester Street at:
  - Metcalfe Street
- Nepean Street at:
  - Elgin Street

The boundary road will be Laurier Avenue West and no screenlines are present within proximity to the site.

#### 3.2 Time Periods

As the proposed development is a mixed-use development with residential units and commercial, the AM and PM peak hours will be examined.

#### 3.3 Horizon Years

The anticipated build-out year is 2027. As a result, the full build-out plus five years horizon year is 2032.

### 4 Exemption Review

Table 8 summarizes the exemptions for this TIA.

*Table 8: Exemption Review*

Module	Element	Explanation	Exempt/Required
<b>Design Review Component</b>			
<b>4.1 Development Design</b>	4.1.2 Circulation and Access	Only required for site plans	Required
	4.1.3 New Street Networks	Only required for plans of subdivision	Exempt
<b>4.2 Parking</b>	4.2.1 Parking Supply	Only required for site plans	Required
	4.2.2 Spillover Parking	Only required for site plans where parking supply is 15% below unconstrained demand	Exempt
<b>Network Impact Component</b>			
<b>4.5 Transportation Demand Management</b>	All Elements	Not required for site plans expected to have fewer than 60 employees and/or students on location at any given time	Required
<b>4.6 Neighbourhood Traffic Management</b>	4.6.1 Adjacent Neighbourhoods	Only required when the development relies on local or collector streets for access and total volumes exceed ATM capacity thresholds	Exempt
<b>4.8 Network Concept</b>		Only required when proposed development generates more than 200 person-trips during the peak hour in excess	Exempt

Module	Element	Explanation	Exempt/Required
		of equivalent volume permitted by established zoning	

## 5 Development-Generated Travel Demand

### 5.1 Mode Shares

Examining the mode shares recommended in the TRANS Trip Generation Manual (2020) for the subject district, derived from the most recent National Capital Region Origin-Destination survey (OD Survey), the existing average district mode shares by land use for Ottawa Inner Area have been summarized in Table 9.

Table 9: TRANS Trip Generation Manual Recommended Mode Shares – Ottawa Inner Area

Travel Mode	Multi-Unit (High-Rise)		Commercial Generator	
	AM	PM	AM	PM
Auto Driver	26%	25%	39%	22%
Auto Passenger	6%	8%	2%	4%
Transit	28%	21%	16%	12%
Cycling	5%	6%	3%	4%
Walking	34%	39%	40%	58%
<b>Total</b>	<b>100%</b>	<b>100%</b>	<b>100%</b>	<b>100%</b>

Being within 650 metres-walk (or a 450 metres linear distance) of the Parliament LRT station, a higher transit mode is considered achievable at this location. A five percent shift to transit mode from the auto mode is proposed for each of the land use. The proposed modified mode share targets are summarized in Table 10.

Table 10: Proposed Development Mode Shares – Within 450 m of Rapid Transit

Travel Mode	Single-Detached		Multi-Unit (Low-Rise)	
	AM	PM	AM	PM
Auto Driver	21%	20%	34%	17%
Auto Passenger	6%	8%	2%	4%
Transit	33%	26%	21%	17%
Cycling	5%	6%	3%	4%
Walking	34%	39%	40%	58%
<b>Total</b>	<b>100%</b>	<b>100%</b>	<b>100%</b>	<b>100%</b>

### 5.2 Trip Generation

This TIA has been prepared using the vehicle and person trip rates for the residential dwellings using the TRANS Trip Generation Manual (2020) and the vehicle trip rates and derived person trip rates for commercial component from the ITE Trip Generation Manual 10th Edition (2017) using the City-prescribed conversion factor of 1.28. Table 11 summarizes the person trip rates for the proposed residential land uses for each peak period and the person trip rates for the non-residential land uses by peak hour.

Table 11: Trip Generation Person Trip Rates by Peak Period

Land Use	Land Use Code	Peak Period	Vehicle Trip Rate	Person Trip Rates
Multi-Unit (High-Rise)	221 & 222 (TRANS)	AM	-	0.80
		PM	-	0.90
Land Use	Land Use Code	Peak Hour	Vehicle Trip Rate	Person Trip Rates
Strip Retail Plaza (<40k)	822 (ITE)	AM	2.36	3.02
		PM	6.59	8.44

Using the above person trip rates, the total person trip generation has been estimated. Table 12 summarizes the total person trip generation for the residential land uses and for the non-residential land uses.

*Table 12: Total Residential Person Trip Generation by Peak Period*

Land Use	Units	AM Peak Period			PM Peak Period		
		In	Out	Total	In	Out	Total
<b>Multi-Unit (High-Rise)</b>	312	78	173	250	163	118	281
Land Use	GFA	AM Peak Hour			PM Peak Hour		
		In	Out	Total	In	Out	Total
<b>Strip Retail Plaza (&lt;40k)</b>	4,117 sq. ft	7	5	12	18	18	35

Internal capture rates from the ITE Trip Generation Handbook 3<sup>rd</sup> Edition have been assigned to the development's retail component for mixed-use developments. The rates summarized in Table 13 represent the percentage of trips to/from the retail use based on the residential component.

*Table 13: Internal Capture Rates*

Land Use	AM		PM	
	In	Out	In	Out
<b>Residential to/from Strip Retail Plaza (&lt;40k)</b>	17%	14%	10%	26%

Pass-by reductions applied to the retail trip generation at a rate of 35% have been included, a value taken as a moderately conservative interpretation from the rates presented in the ITE Trip Generation Handbook 3<sup>rd</sup> Edition.

Using the above mode share targets for a LRT area, the internal capture and pass-by rates, and the person trip rates, the person trips by mode have been projected. Trip generation by peak hour has been forecasted using the prescribed peak period conversion factors presented in the TRANS Trip Generation Manual (2020) for the residential component. Table 14 summarizes the residential trip generation and the non-residential trip generation by mode and peak hour.

Table 14: Trip Generation by Mode

Travel Mode		AM Peak Hour				PM Peak Hour			
		Mode Share	In	Out	Total	Mode Share	In	Out	Total
Multi-Unit (High-Rise)	Auto Driver	21%	8	17	25	20%	15	11	26
	Auto Passenger	6%	2	5	7	8%	6	4	10
	Transit	33%	14	31	45	26%	20	15	35
	Cycling	5%	2	5	7	6%	5	3	8
	Walking	34%	16	34	50	39%	33	24	57
	<b>Total</b>	<b>100%</b>	<b>42</b>	<b>92</b>	<b>134</b>	<b>100%</b>	<b>79</b>	<b>57</b>	<b>134</b>
Strip Retail Plaza (<40k)	Auto Driver	34%	1	1	2	17%	2	1	3
	Auto Passenger	2%	0	0	0	4%	1	0	1
	Transit	21%	1	1	2	17%	3	2	5
	Cycling	3%	0	0	0	4%	1	0	1
	Walking	40%	2	2	4	58%	9	8	17
	Internal Capture	varies	-1	-1	-2	varies	-2	-5	-7
	Pass-by	35%	-1	0	-1	35%	-1	-1	-2
	<b>Total</b>	<b>100%</b>	<b>4</b>	<b>4</b>	<b>8</b>	<b>100%</b>	<b>16</b>	<b>11</b>	<b>27</b>
Total	Auto Driver	-	9	18	27	-	17	12	29
	Auto Passenger	-	2	5	7	-	7	4	11
	Transit	-	15	32	47	-	23	17	40
	Cycling	-	2	5	7	-	6	3	9
	Walking	-	18	36	54	-	42	32	74
	<b>Total</b>	<b>100%</b>	<b>46</b>	<b>96</b>	<b>142</b>	<b>100%</b>	<b>95</b>	<b>68</b>	<b>163</b>

As shown above, a total of 27 AM and 29 PM new peak hour two-way vehicle trips are projected as a result of the proposed development.

### 5.3 Trip Distribution

To understand the travel patterns of the subject development, the OD Survey has been reviewed to determine the travel, and these patterns were applied based on the build-out of Ottawa Inner. Table 15 below summarizes the distributions.

Table 15: OD Survey Distribution – Ottawa Inner

To/From	% of Trips
North	10%
South	40%
East	10%
West	40%
<b>Total</b>	<b>100%</b>

### 5.4 Trip Assignment

Using the distribution outlined above, turning movement splits, and access to major transportation infrastructure, the trips generated by the site have been assigned to the study area road network. Table 16 summarizes the proportional assignment to the study area roadways, and Figure 12 and Figure 13 illustrate the new site generated volumes and pass-by volumes.

Table 16: Trip Assignment

To/From	Inbound Via	Outbound Via
North	10% Elgin (N)	10% Metcalfe (N)
South	15% Metcalfe (S) 25% Laurier (W)	20% O'Connor (S) 10% Laurier (E) 10% Nepean (S)
East	10% Laurier (E)	10% Laurier (E)
West	40% Laurier (W)	40% Laurier (W)
<b>Total</b>	<b>100%</b>	<b>100%</b>

Figure 12: New Site Generation Auto Volumes

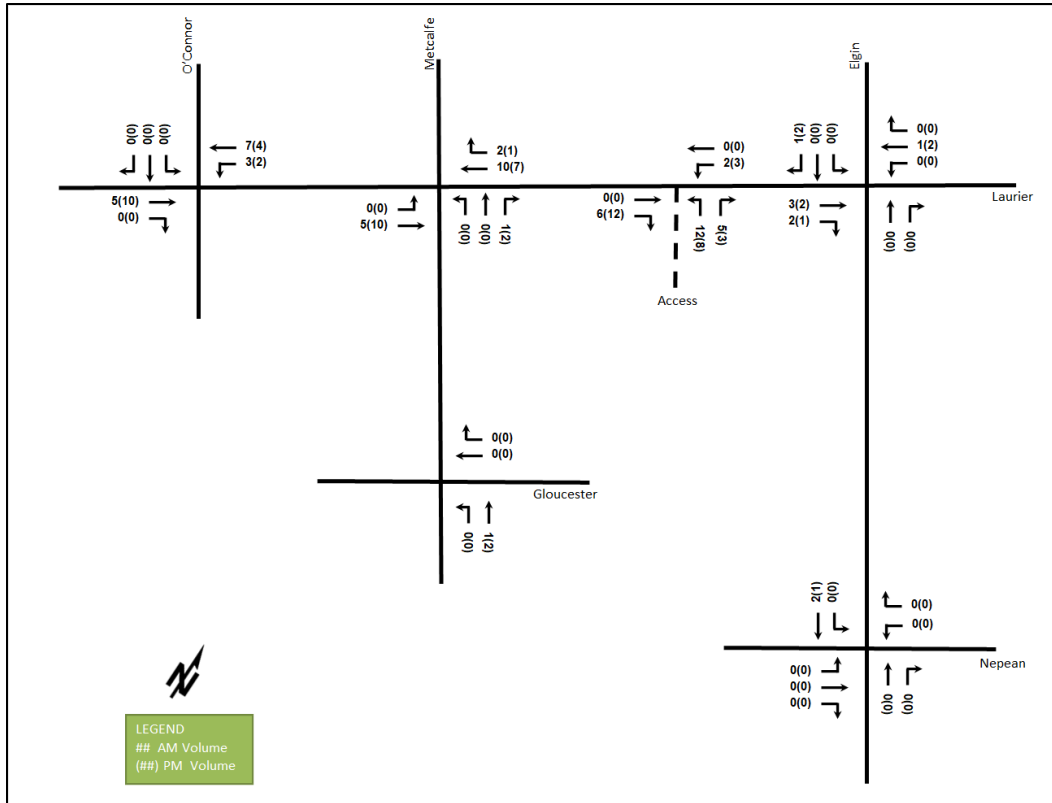
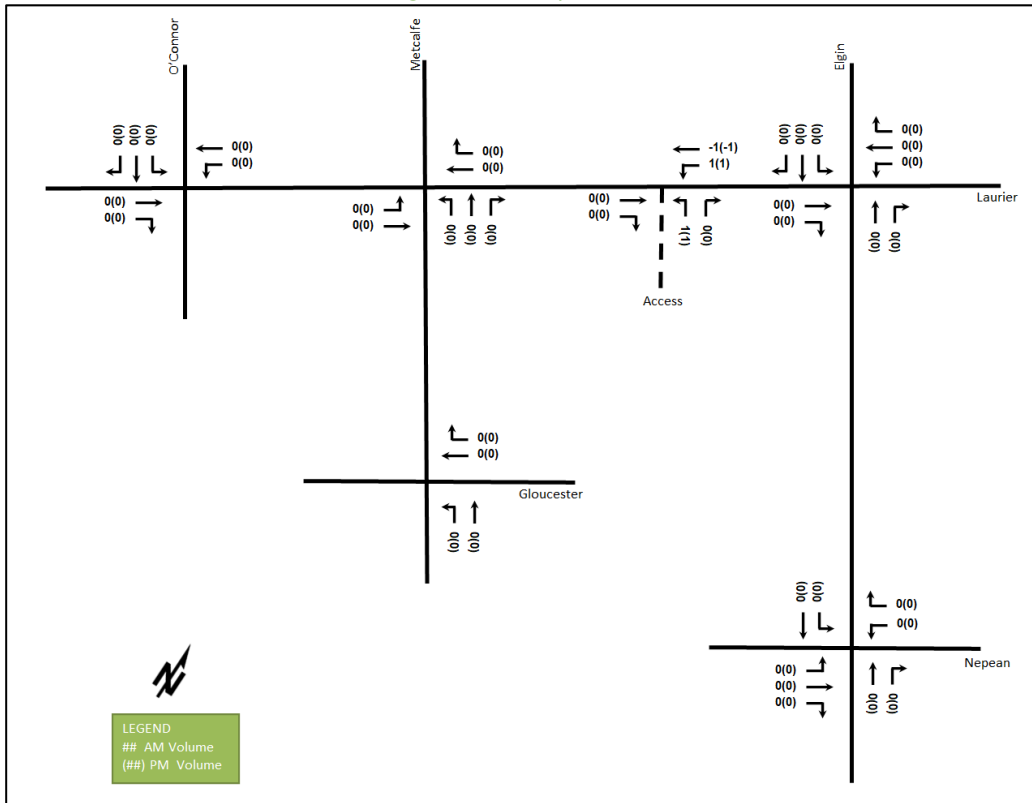

Figure 13: Pass-By Volumes



## 6 Background Network Travel Demands

### 6.1 Transportation Network Plans

The transportation network plans were discussed in Section 2.3 and have been incorporated into the road network analysis.

### 6.2 Background Growth

A review of the background projections from the City’s TRANS Regional Model for the 2011 and 2031 horizons was completed to determine the background growth for each of the study area roadways. The background TRANS model growth rates are summarized in Table 17 and the TRANS model plots are provided in Appendix E.

Table 17: TRANS Regional Model Projections – Study Area Growth Rates

Street	TRANS Rate	
	Eastbound	Westbound
Laurier	-1.10%	-1.08%
	Northbound	Southbound
O’Connor	-	-0.44%
Metcalfe	0.82%	-
Elgin	0.58%	0.61%

Given the various construction activities in the area, such as Elgin Street, a comparison to the existing traffic count data was not conducted. Therefore, the TRANS rates were generally applied to the area road network. It is noted that any negative growth values are conservative considered as 0%. Table 18 summarizes the recommended growth rates to be considered within the study area.



Table 18: Recommended Area Growth Rates

Street	Peak Hour	
	Eastbound	Westbound
Laurier	0%	0%
	Northbound	Southbound
O'Connor	-	0%
Metcalf	1.00%	-
Elgin	0.50%	0.50%

### 6.3 Other Developments

The background developments explicitly considered in the background conditions (Section 6.2) include:

- 208-212 Slater Street
- 180 Metcalfe Street

Figure 14 illustrates the background developments volumes. The background development volumes within the study area have been provided in Appendix F.

Figure 14: Background developments volumes

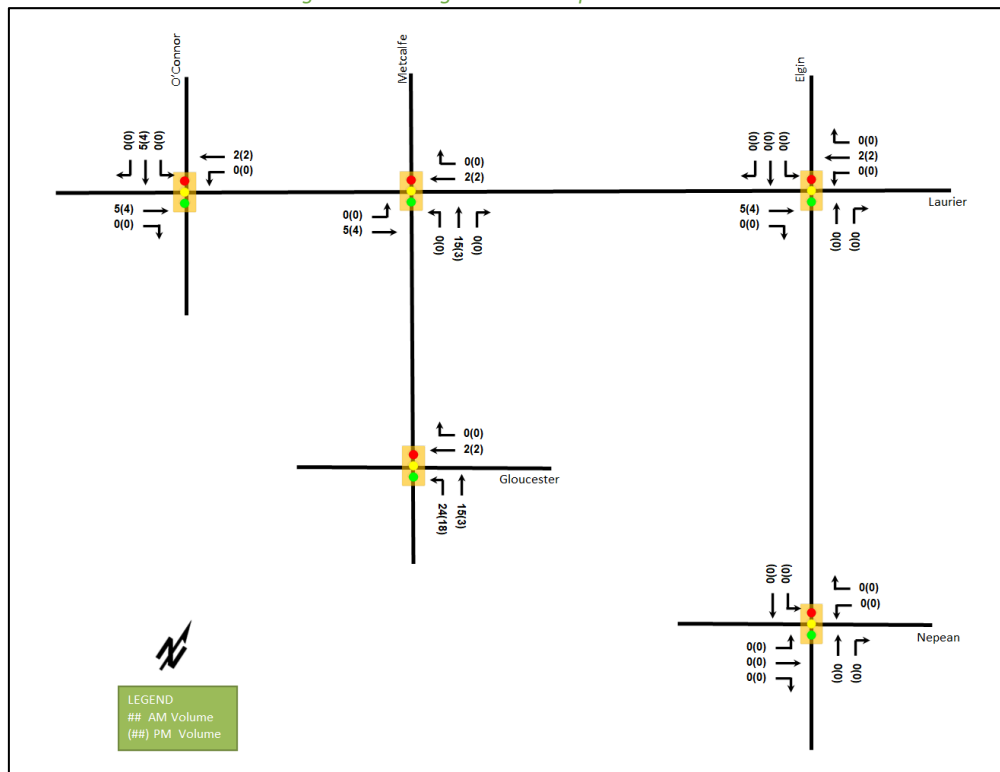

## 7 Demand Rationalization

### 7.1 2027 Future Background Operations

Figure 15 illustrates the 2027 background volumes and Table 19 summarizes the 2027 background intersection operations. The level of service for signalized intersections is based on v/c calculations for individual lane movements and HCM 2000 v/c calculations for the overall intersection. The synchro worksheets for the 2027 future background horizon are provided in Appendix G.

Figure 15: 2027 Future Background Volumes

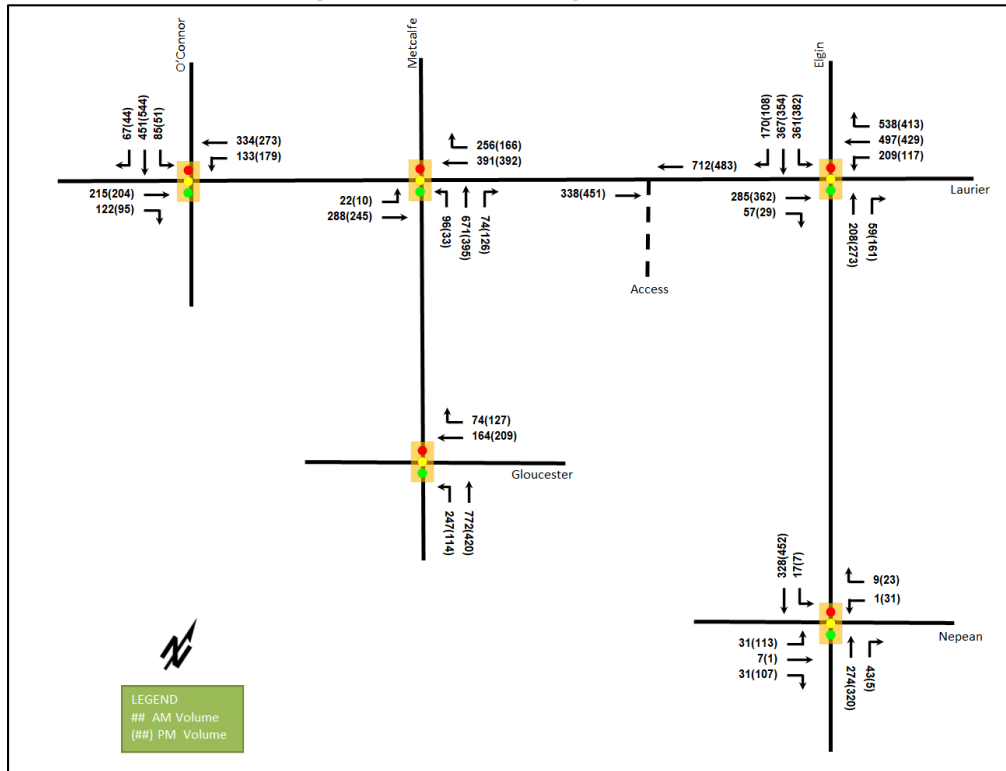

Table 19: 2027 Future Background Intersection Operations

Intersection	Lane	AM Peak Hour				PM Peak Hour			
		LOS	V/C	Delay (s)	Q (95 <sup>th</sup> )	LOS	V/C	Delay (s)	Q (95 <sup>th</sup> )
<b>Laurier Avenue West at O'Connor Street</b> <i>Signalized</i>	EBT/R	B	0.63	25.6	64.6	A	0.60	24.6	62.9
	WBL	A	0.32	7.1	9.3	A	0.48	22.1	37.2
	WBT	A	0.37	6.7	19.7	A	0.33	16.2	46.7
	SB	A	0.50	22.3	34.9	A	0.52	22.4	40.4
	<b>Overall</b>	<b>B</b>	<b>0.61</b>	<b>17.9</b>	-	<b>B</b>	<b>0.61</b>	<b>21.6</b>	-
<b>Laurier Avenue West at Metcalfe Street</b> <i>Signalized</i>	EBL/T	A	0.40	19.1	56.3	A	0.32	6.6	13.5
	WBT/R	A	0.53	15.5	46.1	A	0.42	12.0	37.8
	NB	A	0.55	15.6	47.1	A	0.51	18.1	21.5
	<b>Overall</b>	<b>B</b>	<b>0.56</b>	<b>16.2</b>	-	<b>A</b>	<b>0.47</b>	<b>13.5</b>	-
<b>Laurier Avenue West at Elgin Street</b> <i>Signalized</i>	EBT/R	A	0.39	30.0	40.4	A	0.47	31.2	50.7
	WBL	A	0.59	27.2	41.4	A	0.42	23.1	27.2
	WBT	A	0.58	21.6	97.3	A	0.57	22.0	94.4
	WBR	E	0.91	35.5	<b>#89.7</b>	C	0.77	21.4	<b>#58.5</b>
	NBT	A	0.29	33.7	27.8	A	0.42	25.2	23.2
	NBR	A	0.16	0.9	0.0	A	0.51	8.4	8.5
	SBL	D	0.87	65.4	<b>#60.1</b>	E	0.95	76.6	<b>#71.4</b>
	SBT/R	A	0.49	18.6	46.3	A	0.43	18.8	45.1
<b>Overall</b>	<b>D</b>	<b>0.82</b>	<b>31.4</b>	-	<b>C</b>	<b>0.74</b>	<b>30.2</b>	-	

Intersection	Lane	AM Peak Hour				PM Peak Hour			
		LOS	V/C	Delay (s)	Q (95 <sup>th</sup> )	LOS	V/C	Delay (s)	Q (95 <sup>th</sup> )
<b>Gloucester Street at Metcalfe Street</b> <i>Signalized</i>	WBT/R	A	0.31	20.5	21.3	A	0.38	19.6	30.8
	NBL/T	A	0.39	7.6	29.5	A	0.25	8.2	18.4
	<b>Overall</b>	<b>A</b>	<b>0.35</b>	<b>10.0</b>	-	<b>A</b>	<b>0.29</b>	<b>12.6</b>	-
<b>Nepean Street at Elgin Street</b> <i>Signalized</i>	EB	A	0.16	16.1	14.5	A	0.38	16.5	42.7
	WBL	A	0.00	23.0	1.3	A	0.08	17.1	9.6
	WBR	A	0.02	0.1	0.0	A	0.04	2.0	2.2
	NBT/R	A	0.17	8.0	16.9	A	0.25	17.7	31.8
	SBL	A	0.03	8.2	3.8	A	0.02	13.9	m1.3
	SBT	A	0.17	8.9	18.8	A	0.34	18.0	47.2
	<b>Overall</b>	<b>A</b>	<b>0.16</b>	<b>9.1</b>	-	<b>A</b>	<b>0.35</b>	<b>17.2</b>	-

Notes: Saturation flow rate of 1800 veh/h/lane  
 Queue is measured in metres  
 Peak Hour Factor = 1.00

m = metered queue  
 # = volume for the 95th %ile cycle exceeds capacity

During both the AM and PM peak hours, intersections within the study area will operate similar to existing condition with improvement to the intersection operations due to the adjustment of the peak hour factor to 1.00 for forecasted conditions. No capacity issues are noted.

### 7.2 2032 Future Background Operations

Figure 16 illustrates the 2032 background volumes and Table 20 summarizes the 2032 background intersection operations. The level of service for signalized intersections is based on v/c calculations for individual lane movements and HCM 2000 v/c calculations for the overall intersection. The synchro worksheets for the 2032 future background horizon are provided in Appendix H.

Figure 16: 2032 Future Background Volumes

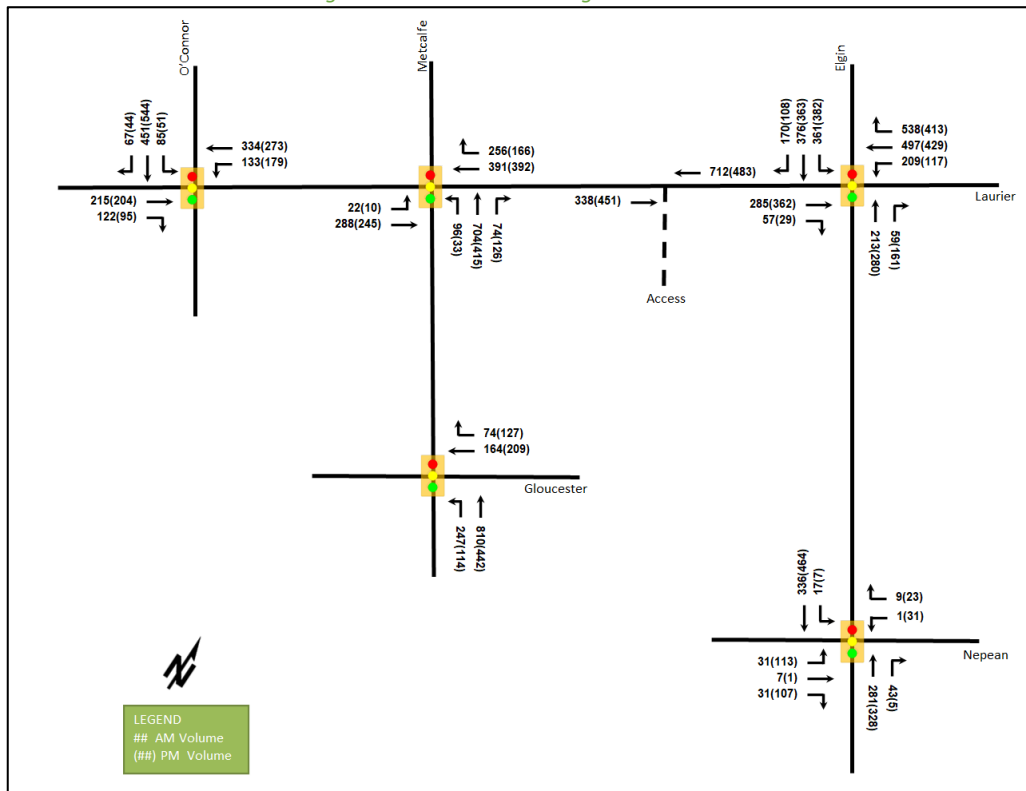

Table 20: 2032 Future Background Intersection Operations

Intersection	Lane	AM Peak Hour				PM Peak Hour			
		LOS	V/C	Delay (s)	Q (95 <sup>th</sup> )	LOS	V/C	Delay (s)	Q (95 <sup>th</sup> )
<b>Laurier Avenue West at O'Connor Street</b> <i>Signalized</i>	EBT/R	B	0.63	25.6	64.6	A	0.60	24.6	62.9
	WBL	A	0.32	7.1	m9.3	A	0.48	22.1	37.2
	WBT	A	0.37	6.7	19.8	A	0.33	16.2	46.7
	SB	A	0.50	22.3	34.9	A	0.52	22.4	40.4
	<b>Overall</b>	<b>B</b>	<b>0.61</b>	<b>17.9</b>	-	<b>B</b>	<b>0.61</b>	<b>21.6</b>	-
<b>Laurier Avenue West at Metcalfe Street</b> <i>Signalized</i>	EBL/T	A	0.40	19.1	56.3	A	0.32	6.6	13.5
	WBT/R	A	0.53	15.5	46.1	A	0.42	12.0	37.8
	NB	A	0.57	15.7	49.0	A	0.53	18.1	21.6
	<b>Overall</b>	<b>A</b>	<b>0.57</b>	<b>16.2</b>	-	<b>A</b>	<b>0.48</b>	<b>13.5</b>	-
<b>Laurier Avenue West at Elgin Street</b> <i>Signalized</i>	EBT/R	A	0.39	30.0	40.4	A	0.47	31.2	50.7
	WBL	A	0.59	27.2	41.4	A	0.42	23.1	27.2
	WBT	A	0.58	21.6	97.3	A	0.57	22.0	94.4
	WBR	E	0.91	35.5	#89.7	C	0.77	21.4	#58.8
	NBT	A	0.29	33.8	28.4	A	0.43	25.1	23.6
	NBR	A	0.16	0.9	0.0	A	0.51	8.4	9.1
	SBL	D	0.87	65.4	#60.1	E	0.95	76.6	#71.4
	<b>Overall</b>	<b>D</b>	<b>0.82</b>	<b>31.5</b>	-	<b>C</b>	<b>0.74</b>	<b>30.1</b>	-
<b>Gloucester Street at Metcalfe Street</b> <i>Signalized</i>	WBT/R	A	0.31	20.8	21.5	A	0.38	19.7	30.9
	NBL/T	A	0.40	7.7	30.9	A	0.26	8.3	19.2
	<b>Overall</b>	<b>A</b>	<b>0.36</b>	<b>10.1</b>	-	<b>A</b>	<b>0.29</b>	<b>12.6</b>	-
<b>Nepean Street at Elgin Street</b> <i>Signalized</i>	EB	A	0.16	16.1	14.5	A	0.38	16.5	42.7
	WBL	A	0.00	23.0	1.3	A	0.08	17.1	9.6
	WBR	A	0.02	0.1	0.0	A	0.04	2.0	2.2
	NBT/R	A	0.18	8.1	17.3	A	0.25	17.8	32.5
	SBL	A	0.03	8.2	3.8	A	0.02	13.9	m1.2
	SBT	A	0.18	9.0	19.3	A	0.35	17.9	48.1
<b>Overall</b>	<b>A</b>	<b>0.16</b>	<b>9.1</b>	-	<b>A</b>	<b>0.36</b>	<b>17.2</b>	-	

Notes: Saturation flow rate of 1800 veh/h/lane  
Queue is measured in metres  
Peak Hour Factor = 1.00

m = metered queue  
# = volume for the 95th %ile cycle exceeds capacity

During both peak hours, intersections within the study area will operate similar to the 2027 future background horizon. No capacity issues are noted.

### 7.3 2027 Future Total Operations

Figure 17 illustrates the 2027 future total volumes and Table 21 summarizes the 2027 future total intersection operations. The level of service for signalized intersections is based on HCM 2010 calculations for individual lane movements and HCM 2000 v/c calculations for the overall intersection, and HCM average delay for unsignalized intersections. The synchro worksheets for the 2027 future total horizon are provided in Appendix I.

Figure 17: 2027 Future Total Volumes

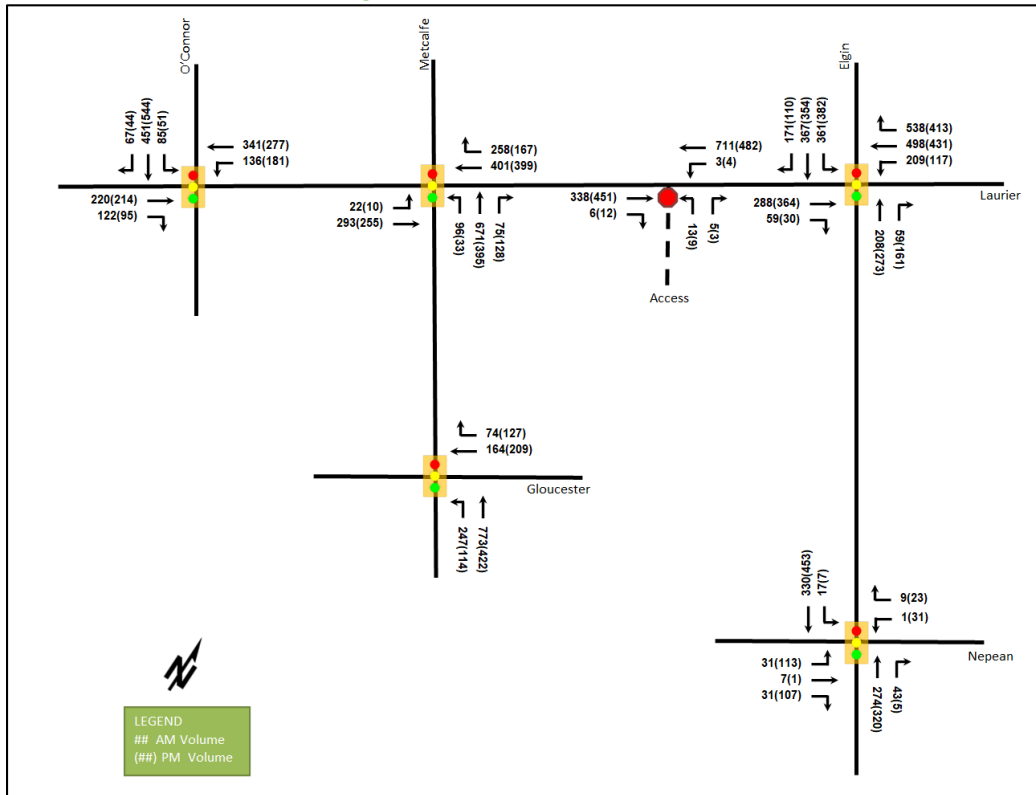

Table 21: 2027 Future Total Intersection Operations

Intersection	Lane	AM Peak Hour				PM Peak Hour			
		LOS	V/C	Delay (s)	Q (95 <sup>th</sup> )	LOS	V/C	Delay (s)	Q (95 <sup>th</sup> )
Laurier Avenue West at O'Connor Street <i>Signalized</i>	EBT/R	B	0.64	25.8	65.9	B	0.62	25.1	65.3
	WBL	A	0.33	7.1	9.4	A	0.49	23.0	38.1
	WBT	A	0.38	6.7	19.8	A	0.34	16.5	47.6
	SB	A	0.50	22.3	34.9	A	0.52	22.4	40.4
	<b>Overall</b>	<b>B</b>	<b>0.62</b>	<b>17.9</b>	-	<b>B</b>	<b>0.62</b>	<b>21.9</b>	-
Laurier Avenue West at Metcalfe Street <i>Signalized</i>	EBL/T	A	0.40	19.3	57.1	A	0.33	6.5	13.4
	WBT/R	A	0.54	15.6	47.2	A	0.43	12.1	38.4
	NB	A	0.56	15.6	47.2	A	0.52	18.1	21.4
	<b>Overall</b>	<b>A</b>	<b>0.56</b>	<b>16.3</b>	-	<b>A</b>	<b>0.48</b>	<b>13.4</b>	-
Laurier Avenue West at Elgin Street <i>Signalized</i>	EBT/R	A	0.39	30.1	41.0	A	0.47	31.2	51.0
	WBL	A	0.59	27.3	41.4	A	0.42	23.1	27.2
	WBT	A	0.58	21.7	97.5	A	0.57	22.0	94.8
	WBR	E	0.91	35.5	#89.7	C	0.77	21.4	#58.5
	NBT	A	0.29	33.7	27.8	A	0.42	25.2	23.2
	NBR	A	0.16	0.9	0.0	A	0.51	8.5	9.0
	SBL	D	0.87	65.4	#60.1	E	0.95	76.6	#71.4
	SBT/R	A	0.49	18.6	46.3	A	0.44	18.8	45.3
<b>Overall</b>	<b>D</b>	<b>0.82</b>	<b>31.4</b>	-	<b>C</b>	<b>0.74</b>	<b>30.2</b>	-	
Gloucester Street at Metcalfe Street <i>Signalized</i>	WBT/R	A	0.31	20.6	21.4	A	0.38	19.6	30.8
	NBL/T	A	0.39	7.6	29.6	A	0.25	8.2	18.5
	<b>Overall</b>	<b>A</b>	<b>0.35</b>	<b>10.0</b>	-	<b>A</b>	<b>0.29</b>	<b>12.6</b>	-

Intersection	Lane	AM Peak Hour				PM Peak Hour			
		LOS	V/C	Delay (s)	Q (95 <sup>th</sup> )	LOS	V/C	Delay (s)	Q (95 <sup>th</sup> )
<b>Nepean Street at Elgin Street Signalized</b>	EB	A	0.16	16.1	14.5	A	0.38	16.5	42.7
	WBL	A	0.00	23.0	1.3	A	0.08	17.1	9.6
	WBR	A	0.02	0.1	0.0	A	0.04	2.0	2.2
	NBT/R	A	0.17	8.0	16.9	A	0.25	17.7	31.8
	SBL	A	0.03	8.2	3.8	A	0.02	14.1	m1.2
	SBT	A	0.17	8.9	19.0	A	0.34	18.1	47.2
<b>Overall</b>	<b>A</b>	<b>0.16</b>	<b>9.1</b>	-	-	<b>A</b>	<b>0.35</b>	<b>17.2</b>	-
<b>Laurier Avenue West at Access Unsignalized</b>	EB	-	-	-	-	-	-	-	-
	WB	A	0.00	8.0	0.0	A	0.00	8.4	0.0
	NB	C	0.06	17.7	1.5	C	0.05	18.0	0.8
	<b>Overall</b>	<b>A</b>	-	<b>0.3</b>	-	-	-	<b>0.3</b>	-

Notes: Saturation flow rate of 1800 veh/h/lane  
 Queue is measured in metres  
 Peak Hour Factor = 1.00

m = metered queue  
 # = volume for the 95th %ile cycle exceeds capacity

During both peak hours, the study area intersection will operate similar to the 2027 future background horizon. No capacity issues are noted. The intersection of Laurier Avenue West at Access will operate well.

### 7.4 2032 Future Total Operations

Figure 18 illustrates the 2032 future total volumes and Table 22 summarizes the 2032 future total intersection operations. The level of service for signalized intersections is based on HCM 2010 calculations for individual lane movements and HCM 2000 v/c calculations for the overall intersection, and HCM average delay for unsignalized intersections. The synchro worksheets for the 2032 future total horizon are provided in Appendix J.

Figure 18: 2032 Future Total Volumes

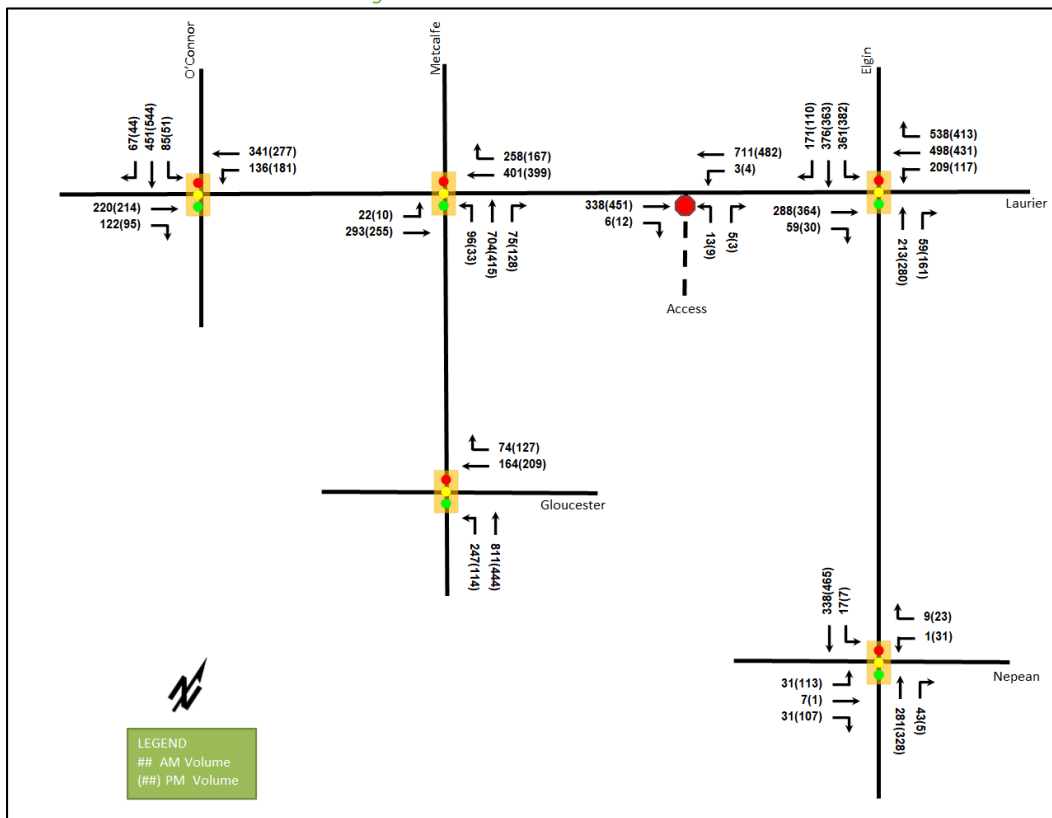

Table 22: 2032 Future Total Intersection Operations

Intersection	Lane	AM Peak Hour				PM Peak Hour			
		LOS	V/C	Delay (s)	Q (95 <sup>th</sup> )	LOS	V/C	Delay (s)	Q (95 <sup>th</sup> )
<b>Laurier Avenue West at O'Connor Street</b> <i>Signalized</i>	EBT/R	B	0.64	25.8	65.9	B	0.62	25.1	65.3
	WBL	A	0.33	7.1	m9.3	A	0.49	23.0	38.1
	WBT	A	0.38	6.7	19.8	A	0.34	16.5	47.6
	SB	A	0.50	22.3	34.9	A	0.52	22.4	40.4
	<b>Overall</b>	<b>B</b>	<b>0.62</b>	<b>17.9</b>	-	<b>B</b>	<b>0.62</b>	<b>21.9</b>	-
<b>Laurier Avenue West at Metcalfe Street</b> <i>Signalized</i>	EBL/T	A	0.40	19.3	57.1	A	0.33	6.5	13.4
	WBT/R	A	0.54	15.6	47.2	A	0.43	12.1	38.4
	NB	A	0.57	15.7	49.0	A	0.53	18.1	21.7
	<b>Overall</b>	<b>A</b>	<b>0.57</b>	<b>16.3</b>	-	<b>A</b>	<b>0.48</b>	<b>13.5</b>	-
<b>Laurier Avenue West at Elgin Street</b> <i>Signalized</i>	EBT/R	A	0.39	30.1	41.0	A	0.47	31.2	51.0
	WBL	A	0.59	27.3	41.4	A	0.42	23.1	27.2
	WBT	A	0.58	21.7	97.5	A	0.57	22.0	94.8
	WBR	E	0.91	35.5	#89.7	C	0.77	21.4	#58.8
	NBT	A	0.29	33.8	28.4	A	0.43	25.1	23.6
	NBR	A	0.16	0.9	0.0	A	0.51	8.4	9.1
	SBL	D	0.87	65.4	#60.1	E	0.95	76.6	#71.4
	<b>Overall</b>	<b>D</b>	<b>0.82</b>	<b>31.5</b>	-	<b>C</b>	<b>0.75</b>	<b>30.2</b>	-
<b>Gloucester Street at Metcalfe Street</b> <i>Signalized</i>	WBT/R	A	0.31	20.8	21.5	A	0.38	19.7	30.9
	NBL/T	A	0.40	7.7	30.9	A	0.26	8.3	19.4
	<b>Overall</b>	<b>A</b>	<b>0.36</b>	<b>10.1</b>	-	<b>A</b>	<b>0.29</b>	<b>12.6</b>	-
<b>Nepean Street at Elgin Street</b> <i>Signalized</i>	EB	A	0.16	16.1	14.5	A	0.38	16.5	42.7
	WBL	A	0.00	23.0	1.3	A	0.08	17.1	9.6
	WBR	A	0.02	0.1	0.0	A	0.04	2.0	2.2
	NBT/R	A	0.18	8.1	17.3	A	0.25	17.8	32.5
	SBL	A	0.03	8.2	3.8	A	0.02	13.6	m1.2
	SBT	A	0.18	9.0	19.4	A	0.35	17.9	48.3
<b>Overall</b>	<b>A</b>	<b>0.16</b>	<b>9.1</b>	-	<b>A</b>	<b>0.36</b>	<b>17.2</b>	-	
<b>Laurier Avenue West at Access</b> <i>Unsignalized</i>	EB	-	-	-	-	-	-	-	-
	WB	A	0.00	8.0	0.0	A	0.00	8.4	0.0
	NB	C	0.06	17.7	1.5	C	0.05	18.0	0.8
	<b>Overall</b>	<b>A</b>	-	<b>0.3</b>	-	<b>A</b>	-	<b>0.3</b>	-

Notes: Saturation flow rate of 1800 veh/h/lane  
Queue is measured in metres  
Peak Hour Factor = 1.00

m = metered queue  
# = volume for the 95th %ile cycle exceeds capacity

During both peak hours, the study area intersection will operate similar to the 2032 future background horizon. No capacity issues are noted.

The intersection of Laurier Avenue West at Access will operate well.

### 7.5 Modal Share Sensitivity and Demand Rationalization Conclusions

No capacity constraints are noted within the study area. As such, no rationalization of the modal share and projected volumes is required.

## 8 Development Design

### 8.1 Design for Sustainable Modes

The proposed development is a mixed-use building with residential and ground floor commercial/retail, with the parking provided on five underground levels and surface. Bicycle parking is provided both external and internal to the building. Three bike racks are provided for external bicycle parking and bike rooms are provided for internal bike parking. Pedestrian and cycling facilities are provided along the boundary street.

### 8.2 Circulation and Access

Vehicle access is provided via a two-way access onto Laurier Avenue West. The two-way access is 6.0m wide and it connects to a 12% slope ramp to the underground parking. Garbage collection is proposed to collect from a staging area located in the southwest corner of the site, and emergency services are proposed to access the site via Laurier Avenue West. Appendix K illustrates the turning templates for the site.

## 9 Parking

### 9.1 Parking Supply

The site provides 170 residential parking spaces, 30 visitor parking spaces, and 300 bicycle spaces. A total of seven vehicle parking and six bicycle parking spaces will be provided on the ground level, and a total of 193 vehicle parking spaces and 294 bicycle parking spaces will be provided below ground level.

No requirement for the residential parking and the minimum parking provision is 30 visitor parking spaces and 158 bicycle parking spaces. The minimum visitor parking and bicycle parking requirements are satisfied.

## 10 Boundary Street Design

Table 23 summarizes the MMLOS analysis for the boundary streets of Laurier Avenue West. The existing and future conditions for both streets will be the same and are considered in one row. The boundary street analysis is based on the policy area of Central Area. The MMLOS worksheets has been provided in Appendix L.

Table 23: Boundary Street MMLOS Analysis

Segment	Pedestrian LOS		Bicycle LOS		Transit LOS		Truck LOS	
	PLOS	Target	BLOS	Target	TLOS	Target	TrLOS	Target
Laurier Avenue West	D	A	A	C	-	-	C	D

Laurier Avenue West does not meet the pedestrian MMLOS targets and would require traffic reductions to below 3000 vehicles a day to meet the target of 'A'.

## 11 Access Intersections Design

### 11.1 Location and Design of Access

The existing surface and underground accesses on the east side will be removed, and the access located on the western limit of the site will remain. The site access is provided as an all-movements driveway onto Laurier Avenue West, and the throat length is approximately 4.0 metres. Given the downtown urban environment, narrow site and low auto volumes anticipated, the typical throat length of 40 metres cannot be accommodated, nor is considered practical for the context. The existing light standard and fire hydrant, which are located east of the existing access, are proposed to be re-located.



The site access will connect to the adjacent arterial road network, and a 12% slope ramp will be provided to access the underground parking at the rear of the site.

### 11.2 Intersection Control

Based upon the projected volumes, the site access will have stop-control on the minor approach. No further traffic control is necessary to address operational issues.

### 11.3 Access Intersection Design

#### 11.3.1 Future Access Intersection Operations

The operations are noted in Section 7.4 and no capacity issues are noted.

#### 11.3.2 Access Intersection MMLoS

The access intersection is unsignalized, and therefore no access intersection MMLoS analysis has been conducted.

#### 11.3.3 Recommended Design Elements

The existing surface and underground accesses on the east side are proposed to be removed, and the existing light standard and fire hydrant, which are located east of the existing access, are proposed to be re-located.

## 12 Transportation Demand Management

### 12.1 Context for TDM

The mode shares used within the TIA represent a shift from auto modes to transit modes. Overall, the modal shares are likely to be achieved and supporting TDM measures should be provided.

The subject site is within the Central Area design priority area. The total bedroom count within the development is anticipated to be 312 including 147 one-bedroom units, 157 two-bedroom units, and eight loft units.

### 12.2 Need and Opportunity

The subject site has been assumed to rely predominantly on all travel modes with an increase in transit ridership with the proximity to the LRT corridors, and those assumptions have been carried through the analysis.

### 12.3 TDM Program

The “suite of post occupancy TDM measures” has been summarized in the TDM checklists for the residential land uses. The checklist is provided in Appendix M. The key TDM measures recommended include:

- Provide bike repair station for site and public use
- Posting of pedestrian, cycling, and transit information and maps at primary entrances/exits
- Inclusion of a 1-month Presto card for first time new townhome purchase and apartment rental, with a set time frame for this offer (e.g. 6-months) from the initial opening of the site
- Unbundle parking cost from purchase or rental costs

## 13 Transit

In Section 5.1 the trip generation by mode was estimated, including an estimate of the number of transit trips that will be generated by the proposed development. Table 24 summarizes the transit trip generation.

Table 24: Trip Generation by Transit Mode

Travel Mode	Mode Share	AM Peak Hour			PM Peak Hour		
		In	Out	Total	In	Out	Total
Transit	Varies	15	32	47	23	17	40

The proposed development is anticipated to generate an additional 47 AM peak hour transit trips and 40 PM peak hour transit trips. Of these trips, 32 outbound AM trips and 23 inbound PM trips are anticipated.

Within 650-metre walking distance to the Parliament LRT station, which provides 5-minute service in the peak hours mainly for trips to/from the east and the west, and routes #6 and #7, which provide 10-15-minute service in the peak hours, provide trips to/from the north and the south. It is expected that the existing transit service will provide adequate transit capacity to support the increase in travel demand by the proposed development. Therefore, no service changes are anticipated as being required to accommodate site-generated transit trips.

### 13.1 Transit Priority

Examining the study area intersection delays, negligible impacts are noted on transit movements at the study area intersections as a result of the development site traffic.

## 14 Network Intersection Design

### 14.1 Network Intersection Control

No change to the existing signalized control is recommended for the network intersections.

### 14.2 Network Intersection Design

#### 14.2.1 2027 & 2032 Future Total Network Intersection Operations

The operations are noted in Section 7.4 and no capacity issues are noted.

#### 14.2.2 Network Intersection MMLoS

Table 25 summarizes the MMLoS analysis for the network intersections within the study area. The existing and future conditions for both intersections will be the same and are considered in one row. The intersection analysis is based on the policy area of Central Area. The MMLoS worksheets has been provided in Appendix L.

Table 25: Study Area Intersection MMLoS Analysis

Intersection	Pedestrian LOS		Bicycle LOS		Transit LOS		Truck LOS		Auto LOS	
	PLOS	Target	BLOS	Target	TLOS	Target	TrLOS	Target	ALOS	Target
Laurier Avenue West at O'Connor Street	D	A	A	C	-	-	F	D	B	E
Laurier Avenue West at Metcalfe Street	D	A	F	C	-	-	F	D	A	E
Laurier Avenue West at Elgin Street	F	A	F	C	E	D	E	D	D	E
Gloucester Street at Metcalfe Street	C	A	F	B	-	-	-	-	A	E
Nepean Street at Elgin Street	F	A	F	B	C	D	-	-	A	E

The pedestrian LOS targets will not be met at the intersections within the study area. As typical for arterial roads, the crossing distance does not permit the targets to be met. To meet pedestrian LOS targets, the maximum crossing distance on all pedestrian crossings would need to be reduced to two lane-widths.

The bicycle LOS targets will not be met at the intersections within the study area except for the Laurier Avenue West at O'Connor Street intersection. To meet bicycle LOS targets, the left-turn configurations would need to be two-stage or include turn boxes at the intersections along Metcalfe Street and Elgin Street.

The truck LOS targets will not be met at the intersection of Laurier Avenue West at Elgin Street and would need the delay to be below 30 seconds.

The truck LOS targets will not be met at the intersections along Laurier Avenue West and would need at least 15-meter effective corner radius or at least two receiving lands on departure from intersection.

#### 14.2.3 Recommended Design Elements

No study area intersection design elements are proposed as part of this study.

## 15 Summary of Improvements Indicated and Modifications Options

The following summarizes the analysis and results presented in this TIA report:

### Proposed Site and Screening

- The proposed site includes 312 residential units and 4,125 sq. ft. of commercial/retail
- The existing surface and underground accesses on the east side will be removed
- An access on the western limit of the site on Laurier Avenue West will remain
- The development is proposed to be completed as a single phase by 2027
- The trip generation, location, and safety triggers were met for the TIA Screening

### Existing Conditions

- Laurier Avenue West, O'Connor Street, Metcalfe Street, and Elgin Street are arterial roads, and Gloucester Street and Nepean Street are local roads in the study area
- Protected bikes lanes are provided on both sides along Laurier Avenue West west of Elgin Street, a bike lane and cycletrack to the east of Elgin, a two-way protected bikes lane on the east side of O'Connor Street south of Laurier Avenue West, and a southbound transition is located to the north
- Cycle track is provided on the south side and on-street bike lane is provided on the north side along Laurier Avenue West east of Elgin Street
- Sidewalks are provided on both sides along all roads within the study area
- Laurier Avenue West, Metcalfe Street, O'Connor Street, and Elgin Street north of Laurier Avenue West are spine routes and Elgin Street south of Laurier Avenue West is a local route
- Elgin Street north of Laurier Avenue West, Laurier Avenue West, and O'Connor Street are cross-town bikeways
- The high volumes roadways have produced a high number of collisions at the study area intersections, primarily at the Elgin Street at Laurier Avenue intersection (61% or 69 collisions), predominantly represented by sideswipe collisions, which may be contributed by general congestion and the skew of the through movements crossing the intersection
- The westbound right-turn movement at Laurier Avenue West and Elgin Street intersection is over theoretical capacity and may be subject to extended queues during the AM peak in the existing condition.

### Development Generated Travel Demand

- The proposed development is forecasted produce 142 two-way people trips during the AM peak hour and 163 two-way people trips during the PM peak hour

- Of the forecasted people trips, 27 two-way trips will be vehicle trips during the AM peak hour and 29 two-way trips will be vehicle trips during the PM peak hour
- Of the forecasted trips, 20% are anticipated to travel to the north and the east and 40% to the south and the west

### **Background Conditions**

- The background developments were explicitly included in the background conditions, along with background growth on Metcalfe Street and Elgin Street along the mainline volumes
- The study area intersections at future background horizons will operate similar to the existing conditions

### **Development Design**

- The bike parking is provided both external and internal to the building
- Parking provided on five underground levels and surface
- The two-way access is 6.0m wide and it connects to a 12% slope ramp to the underground parking
- Pedestrian and cycling facilities are provided along the boundary street
- The existing light standard and fire hydrant, which are located east of the existing access, are proposed to be re-located
- Garbage collection is proposed to collect from a staging area located in the southwest corner of the site
- Emergency services are proposed to access the site via Laurier Avenue West

### **Parking**

- The site provides 170 residential parking spaces, 30 visitor parking spaces, and 300 bicycle parking spaces
- No requirement for the residential parking
- The minimum visitor parking and bicycle parking requirements are satisfied

### **Boundary Street Design**

- Laurier Avenue West does not meet the pedestrian MMLOS targets due to the vehicle volumes along the corridor

### **Access Intersections Design**

- The site access is provided as an all-movements driveway onto Laurier Avenue West, and the throat length is approximately 4.0 metres
- Given the downtown urban environment, narrow site and low auto volumes anticipated, the typical throat length of 40 metres cannot be accommodated, nor is considered practical for the context
- The site access will connect to the adjacent arterial road network, and a 12% slope ramp will be provided to access the underground parking at the rear of the site
- The site access will have stop-control on the minor approach
- The existing surface and underground accesses on the east side are proposed to be removed
- The existing light standard and fire hydrant, which are located east of the existing access, are proposed to be re-located

### **TDM**

- Supportive TDM measures to be included within the proposed development should include:
  - Provide bike repair station for site and public use

- Posting of pedestrian, cycling, and transit information and maps at primary entrances/exits
- Inclusion of a 1-month Presto card for first time new townhome purchase and apartment rental, with a set time frame for this offer (e.g. 6-months) from the initial opening of the site
- Unbundle parking cost from purchase or rental costs

### Transit

- Parliament LRT station and existing transit routes are expected to provide adequate transit capacity to support the increase transit trips
- No service changes are anticipated as being required to accommodate site-generated transit trips
- Negligible impacts are noted on transit movements at the study area intersections

### Network Intersection Design

- No capacity issues are noted at the intersections within the study
- No change to the existing signalized control is recommended for the network intersections
- The pedestrian LOS targets will not be met at intersections within the study area, which require crossing distances need to be reduced to equal or less than two lane widths
- The bicycle LOS targets will not be met at the existing or future intersections within the study area except for the Laurier Avenue West at O'Connor Street intersection, and it is limited by the lack of dedicated facilities and improved left-turn configurations
- The transit LOS targets will not be met at the intersections of Laurier Avenue West at Elgin Street, which requires the delay to be below 30 seconds
- The truck LOS targets will not be met at the intersections along Laurier Avenue West and would need at least 15-meter effective corner radius or at least two receiving lands on departure from intersection

## 16 Conclusion

It is recommended that, from a transportation perspective, the proposed development applications proceed.

Prepared By:



Yu-Chu Chen, EIT  
Transportation Engineering-Intern

Reviewed By:



Andrew Harte, P.Eng.  
Senior Transportation Engineer

# Appendix A

TIA Screening Form and PM Certification Form

City of Ottawa 2017 TIA Guidelines  
Step 1 - Screening Form

Date: 29-Aug-22  
Project Number: 2022-074  
Project Reference: 150 Laurier

1.1 Description of Proposed Development	
Municipal Address	150 Laurier Avenue West
Description of Location	Ward 14. On Laurier Avenue West between Elgin Street and Metcalfe Street
Land Use Classification	Mixed Use/Commercial Zone ( MD S50)
Development Size	312 residential units and 4,117 sq.ft of commercial space
Accesses	An access on Laurier Avenue West
Phase of Development	Single
Buildout Year	2027
TIA Requirement	Full TIA Required

1.2 Trip Generation Trigger	
Land Use Type	Townhomes or apartments
Development Size	312 Units
Trip Generation Trigger	Yes

1.3 Location Triggers		
Does the development propose a new driveway to a boundary street that is designated as part of the City's Transit Priority, Rapid Transit or Spine Bicycle Networks?	Yes	Laurier Avenue West is a spine route
Is the development in a Design Priority Area (DPA) or Transit-oriented Development (TOD) zone?	Yes	Central Area DPA
Location Trigger	Yes	

1.4. Safety Triggers		
Are posted speed limits on a boundary street 80 km/hr or greater?	No	
Are there any horizontal/vertical curvatures on a boundary street limits sight lines at a proposed driveway?	No	
Is the proposed driveway within the area of influence of an adjacent traffic signal or roundabout (i.e. within 300 m of intersection in rural conditions, or within 150 m of intersection in urban/ suburban conditions)?	Yes	Within 150 of intersections
Is the proposed driveway within auxiliary lanes of an intersection?	No	
Does the proposed driveway make use of an existing median break that serves an existing site?	No	
Is there is a documented history of traffic operations or safety concerns on the boundary streets within 500 m of the development?	Yes	Collisions at Laurier Avenue West and Elgin Street intersection
Does the development include a drive-thru facility?	No	
Safety Trigger	Yes	



## **TIA Plan Reports**

On 14 June 2017, the Council of the City of Ottawa adopted new Transportation Impact Assessment (TIA) Guidelines. In adopting the guidelines, Council established a requirement for those preparing and delivering transportation impact assessments and reports to sign a letter of certification.

Individuals submitting TIA reports will be responsible for all aspects of development-related transportation assessment and reporting, and undertaking such work, in accordance and compliance with the City of Ottawa's Official Plan, the Transportation Master Plan and the Transportation Impact Assessment (2017) Guidelines.

By submitting the attached TIA report (and any associated documents) and signing this document, the individual acknowledges that s/he meets the four criteria listed below.

### **CERTIFICATION**

1. I have reviewed and have a sound understanding of the objectives, needs and requirements of the City of Ottawa's Official Plan, Transportation Master Plan and the Transportation Impact Assessment (2017) Guidelines;
2. I have a sound knowledge of industry standard practice with respect to the preparation of transportation impact assessment reports, including multi modal level of service review;
3. I have substantial experience (more than 5 years) in undertaking and delivering transportation impact studies (analysis, reporting and geometric design) with strong background knowledge in transportation planning, engineering or traffic operations; and
4. I am either a licensed<sup>1</sup> or registered<sup>2</sup> professional in good standing, whose field of expertise [check  appropriate field(s)] is either transportation engineering  or transportation planning .

**1,2 License of registration body that oversees the profession is required to have a code of conduct and ethics guidelines that will ensure appropriate conduct and representation for transportation planning and/or transportation engineering works.**

City Of Ottawa  
Infrastructure Services and Community  
Sustainability  
Planning and Growth Management  
110 Laurier Avenue West, 4th fl.  
Ottawa, ON K1P 1J1  
Tel. : 613-580-2424  
Fax: 613-560-6006

Ville d'Ottawa  
Services d'infrastructure et Viabilité des  
collectivités  
Urbanisme et Gestion de la croissance  
110, avenue Laurier Ouest  
Ottawa (Ontario) K1P 1J1  
Tél. : 613-580-2424  
Télécopieur: 613-560-6006



Dated at Ottawa this 20 day of September, 2018.  
(City)

Name: Andrew Harte  
(Please Print)

Professional Title: Professional Engineer

  
\_\_\_\_\_  
Signature of Individual certifier that s/he meets the above four criteria

<b>Office Contact Information (Please Print)</b>
Address: 6 Plaza Court
City / Postal Code: Ottawa / K2H 7W1
Telephone / Extension: (613) 697-3797
E-Mail Address: Andrew.Harte@CGHTransportation.com



# Appendix B

Turning Movement Counts



## Turning Movement Count Summary Report Including Peak Hours, AADT and Expansion Factors All Vehicles Except Bicycles



### Elgin Street & Nepean Street Ottawa, ON

**Survey Date:** Tuesday, July 12, 2022      **Start Time:** 0700      **AADT Factor:** 0.9  
**Weather AM:** Overcast 20° C      **Survey Duration:** 8 Hrs.      **Survey Hours:** 0700-1000, 1130-1330 & 1500-1800  
**Weather PM:** Mostly Cloudy 23° C      **Surveyor(s):** T. Carmody

Time Period	Nepean St. Eastbound					Ottawa City Hall Westbound					Elgin St. Northbound					Elgin St. Southbound					Street Total	Grand Total	
	LT	ST	RT	UT	E/B Tot	LT	ST	RT	UT	W/B Tot	LT	ST	RT	UT	N/B Tot	LT	ST	RT	UT	S/B Tot			
	Street Total																						
0700-0800	41	5	30	0	76	2	0	2	0	4	80	0	190	21	1	212	6	208	0	6	220	432	512
0800-0900	30	6	31	0	67	1	0	8	0	9	76	0	263	37	0	300	17	309	0	13	339	639	715
0900-1000	36	4	36	0	76	4	0	9	0	13	89	0	280	30	2	312	11	276	0	6	293	605	694
1130-1230	41	2	41	0	84	12	0	18	0	30	114	0	278	15	2	295	7	386	0	11	404	699	813
1230-1330	30	1	59	0	90	15	0	11	0	26	116	0	283	21	2	306	7	382	0	6	395	701	817
1500-1600	82	5	64	0	151	30	0	24	0	54	205	1	284	7	0	292	5	379	0	5	389	681	886
1600-1700	108	2	105	0	215	27	0	21	0	48	263	0	300	3	1	304	7	431	0	11	449	753	1016
1700-1800	99	0	85	0	184	15	0	26	0	41	225	0	273	7	1	281	1	452	0	8	461	742	967
<b>Totals</b>	<b>467</b>	<b>25</b>	<b>451</b>	<b>0</b>	<b>943</b>	<b>106</b>	<b>0</b>	<b>119</b>	<b>0</b>	<b>225</b>	<b>1168</b>	<b>1</b>	<b>2151</b>	<b>141</b>	<b>9</b>	<b>2302</b>	<b>61</b>	<b>2823</b>	<b>0</b>	<b>66</b>	<b>2950</b>	<b>5252</b>	<b>6420</b>

**Equivalent 12 & 24-hour Vehicle Volumes Including the Annual Average Daily Traffic (AADT) Factor**  
 Applicable to the Day and Month of the Turning Movement Count  
 Expansion factors are applied exclusively to standard weekday 8-hour turning movement counts conducted during the hours of 0700h - 1000h, 1130h - 1330h and 1500h - 1800h

Equivalent 12-hour vehicle volumes. These volumes are calculated by multiplying the 8-hour totals by the 8 → 12 expansion factor of 1.39																							
Equ. 12 Hr	649	35	627	0	1311	147	0	165	0	313	1624	1	2990	196	13	3200	85	3924	0	92	4101	7300	8924

Average daily 12-hour vehicle volumes. These volumes are calculated by multiplying the equivalent 12-hour totals by the AADT factor of: 0.9																							
AADT 12-hr	584	31	564	0	1180	133	0	149	0	281	1461	1	2691	176	11	2880	76	3532	0	83	3690	6570	8031

24-Hour AADT. These volumes are calculated by multiplying the average daily 12-hour vehicle volumes by the 12 → 24 expansion factor of 1.31																							
AADT 24 Hr	765	41	739	0	1545	174	0	195	0	369	1914	2	3525	231	15	3773	100	4626	0	108	4834	8607	10521

#### AADT and expansion factors provided by the City of Ottawa

AM Peak Hour Factor → 0.96					Highest Hourly Vehicle Volume Between 0700h & 1000h																				
AM Peak Hr	LT	ST	RT	UT	Total	Str. Tot.	LT	ST	RT	UT	Total	Str. Tot.	LT	ST	RT	UT	Total	Str. Tot.	LT	ST	RT	UT	Total	Str. Tot.	Gr. Tot.
0815-0915	31	7	31	0	69	10	79	0	267	43	0	310	17	320	0	13	350	660	739						
OFF Peak Hour Factor → 0.99					Highest Hourly Vehicle Volume Between 1130h & 1330h																				
OFF Peak Hr	LT	ST	RT	UT	Total	Str. Tot.	LT	ST	RT	UT	Total	Str. Tot.	LT	ST	RT	UT	Total	Str. Tot.	LT	ST	RT	UT	Total	Str. Tot.	Gr. Tot.
1200-1300	42	1	47	0	90	28	118	0	293	15	2	310	7	403	0	5	415	725	843						
PM Peak Hour Factor → 0.97					Highest Hourly Vehicle Volume Between 1500h & 1800h																				
PM Peak Hr	LT	ST	RT	UT	Total	Str. Tot.	LT	ST	RT	UT	Total	Str. Tot.	LT	ST	RT	UT	Total	Str. Tot.	LT	ST	RT	UT	Total	Str. Tot.	Gr. Tot.
1545-1645	113	1	107	0	221	54	275	1	312	5	1	319	7	441	0	8	456	775	1050						

**Comments:**  
 OC Transpo and Para Transpo buses, private buses and school buses comprise 49.08% of the heavy vehicle traffic. The bicycle totals include 26 E-scooters (both stand-up type and Vespa style). The pedestrian crossing totals include 11 pedestrians with accessibility issues using either a cane, walker or electric wheelchair. Many pedestrians and cyclists either cross or drive through the intersection on a red signal.

- Notes:**  
 1. Includes all vehicle types except bicycles, electric bicycles, and electric scooters.  
 2. When expansion and AADT factors are applied, the results will differ slightly due to rounding.



## Turning Movement Count Summary, AM and PM Peak Hour Flow Diagrams All Vehicles Except Bicycles



### Elgin Street & Nepean Street Ottawa, ON

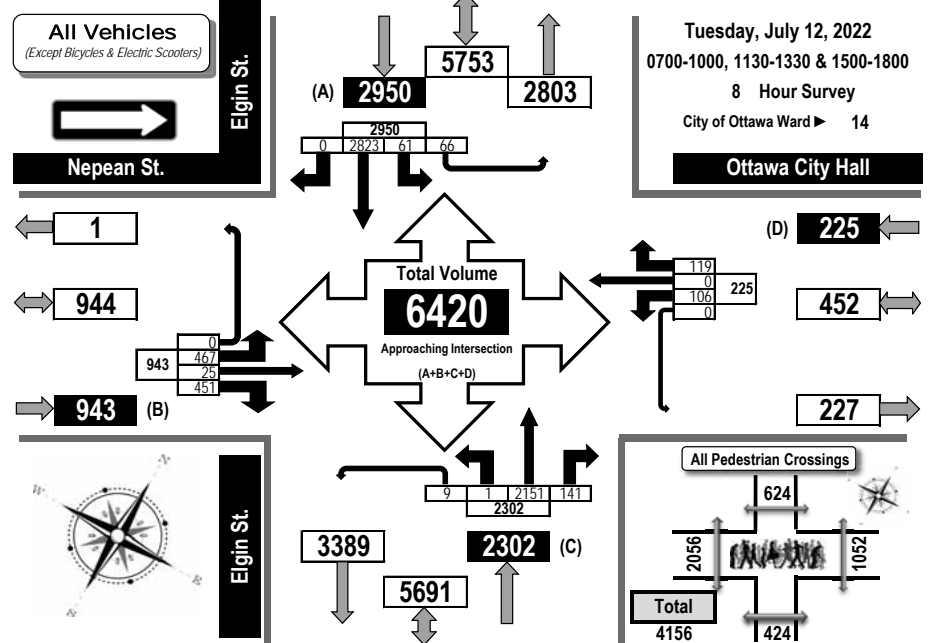

### AM Peak Hour Flow Diagram PM Peak Hour Flow Diagram

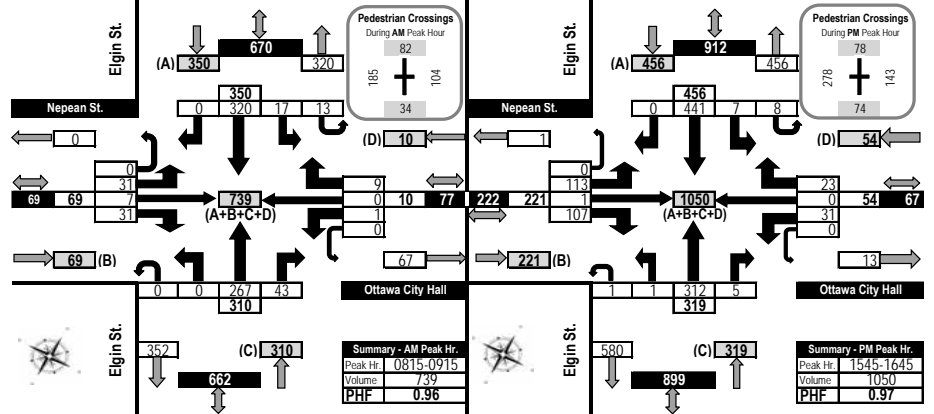



### Turning Movement Count Summary, OFF and EVENING Peak Hour Flow Diagrams All Vehicles Except Bicycles

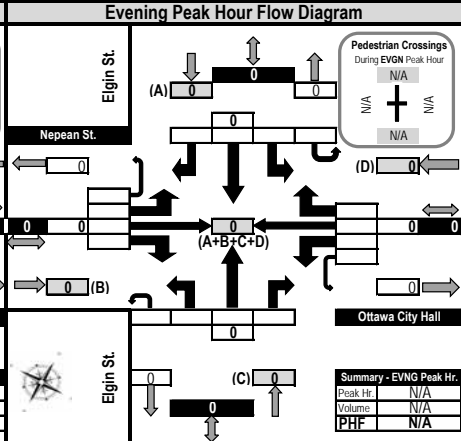
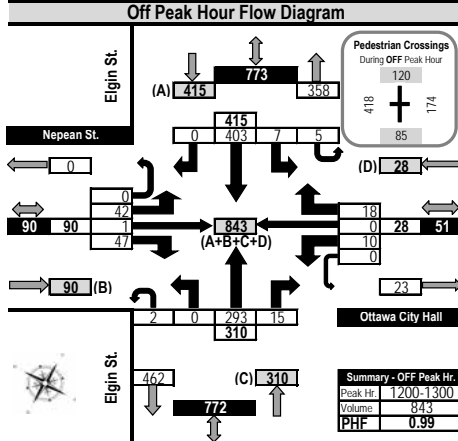
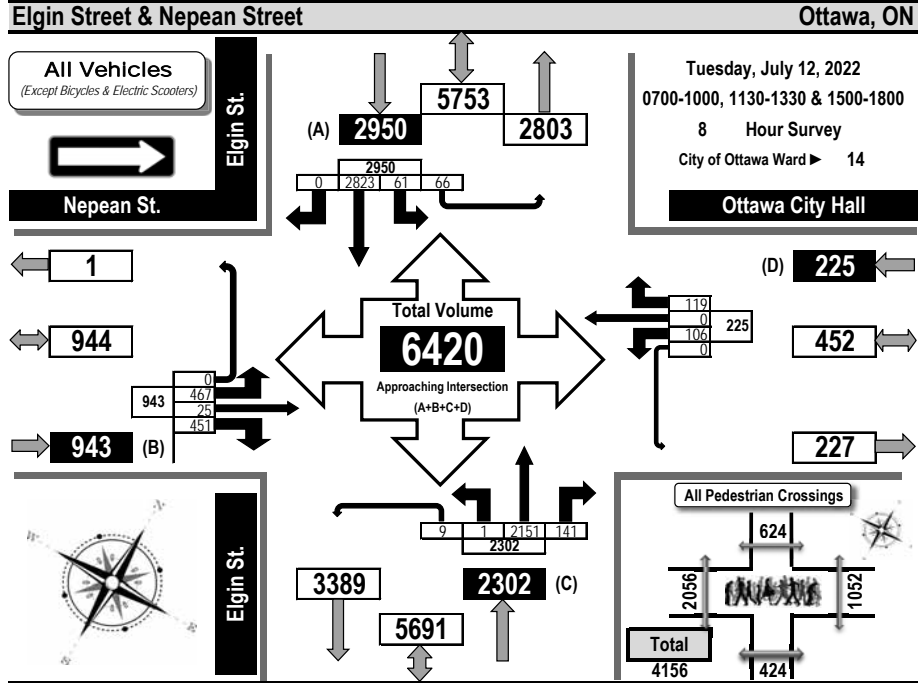

Printed on: 7/15/2022

Prepared by: thetrafficsspecialist@gmail.com

Flow Diagrams: OFF Peak



### Turning Movement Count Heavy Vehicle Summary (FHWA Class 4-13) Flow Diagram

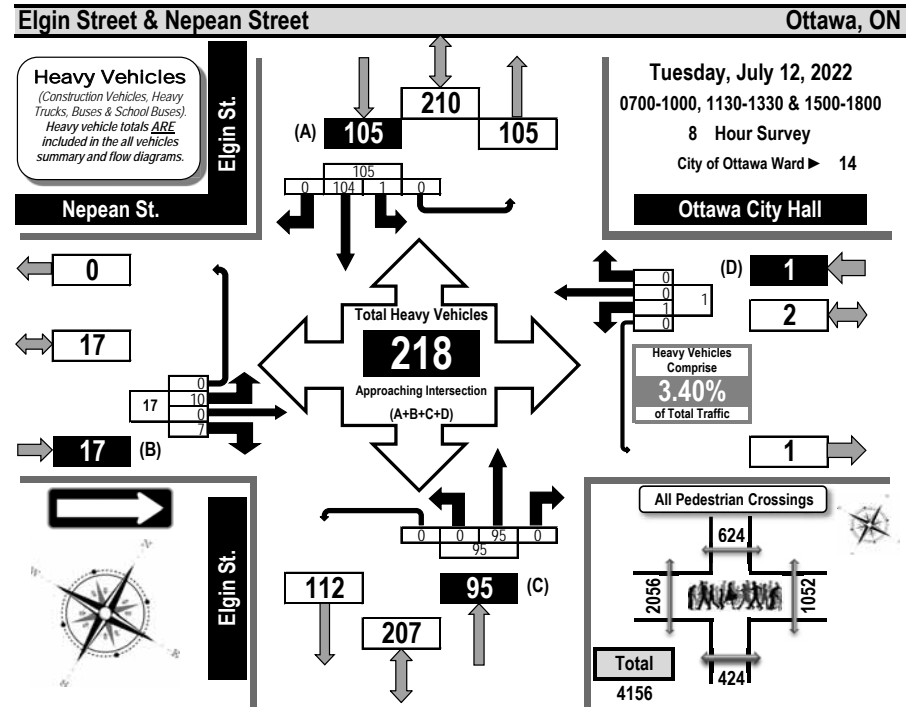

Time Period	Nepean St. Eastbound				Ottawa City Hall Westbound				Elgin St. Northbound				Elgin St. Southbound				SB Tot	GR Tot			
	LT	ST	RT	UT	EB Tot	LT	ST	RT	UT	WB Tot	LT	ST	RT	UT	NB Tot	LT			ST	RT	UT
0700-0800	1	0	1	0	2	0	0	0	0	0	0	11	0	0	11	0	11	0	0	11	24
0800-0900	2	0	2	0	4	0	0	0	0	0	0	14	0	0	14	0	14	0	0	14	32
0900-1000	5	0	1	0	6	0	0	0	0	0	0	14	0	0	14	0	15	0	0	15	35
1130-1230	0	0	2	0	2	0	0	0	0	0	0	15	0	0	15	0	18	0	0	18	35
1230-1330	1	0	0	0	1	0	0	0	0	0	0	14	0	0	14	0	14	0	0	14	29
1500-1600	1	0	1	0	2	1	0	0	0	1	0	10	0	0	10	1	13	0	0	14	27
1600-1700	0	0	0	0	0	0	0	0	0	0	0	9	0	0	9	0	10	0	0	10	19
1700-1800	0	0	0	0	0	0	0	0	0	0	0	8	0	0	8	0	9	0	0	9	17
<b>Totals</b>	<b>10</b>	<b>0</b>	<b>7</b>	<b>0</b>	<b>17</b>	<b>1</b>	<b>0</b>	<b>0</b>	<b>0</b>	<b>1</b>	<b>0</b>	<b>95</b>	<b>0</b>	<b>0</b>	<b>95</b>	<b>1</b>	<b>104</b>	<b>0</b>	<b>0</b>	<b>105</b>	<b>218</b>

**Comments:**

OC Transpo and Para Transpo buses, private buses and school buses comprise 49.08% of the heavy vehicle traffic. The bicycle totals include 26 E-scooters (both stand-up type and Vespa style). The pedestrian crossing totals include 11 pedestrians with accessibility issues using either a cane, walker or electric wheelchair. Many pedestrians and cyclists either cross or drive through the intersection on a red signal.

Printed on: 7/15/2022

Prepared by: thetrafficsspecialist@gmail.com

Summary: Heavy Vehicles



### Turning Movement Count Bicycle Summary Flow Diagram



#### Elgin Street & Nepean Street Ottawa, ON

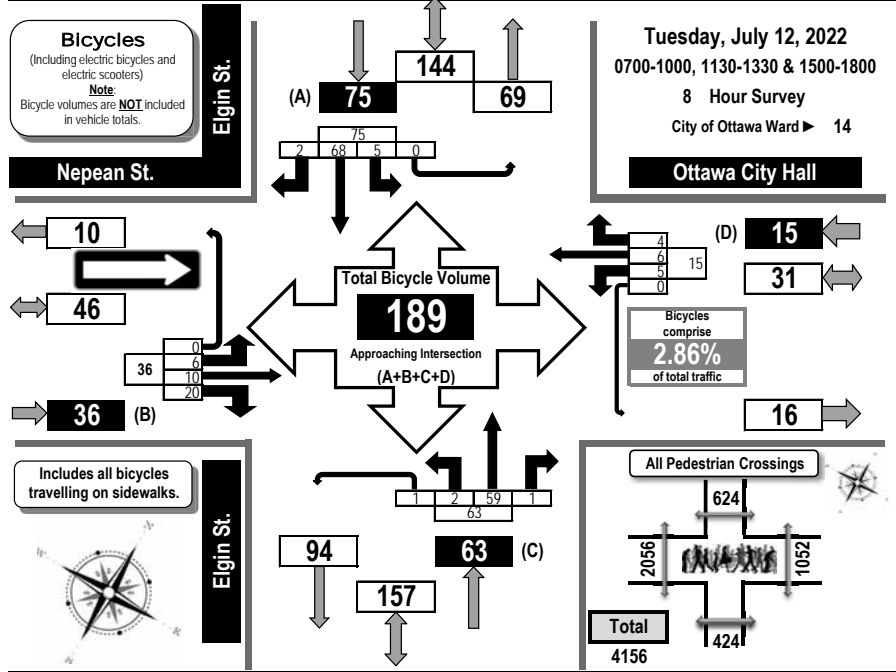

Time Period	Nepean St.				Ottawa City Hall				Elgin St.				Elgin St.				GR Tot				
	Eastbound				Westbound				Northbound				Southbound								
	LT	ST	RT	UT	EB Tot	LT	ST	RT	UT	WB Tot	LT	ST	RT	UT	NB Tot	LT		ST	RT	UT	SB Tot
0700-0800	0	0	1	0	1	0	2	1	0	3	0	6	1	0	7	0	1	0	0	1	12
0800-0900	1	0	1	0	2	0	0	2	0	2	0	5	0	0	5	0	3	0	0	3	12
0900-1000	1	1	2	0	4	0	1	0	0	1	0	8	0	0	8	0	5	0	0	5	18
1130-1230	0	1	1	0	2	1	0	0	0	1	0	5	0	0	5	1	12	0	0	13	21
1230-1330	0	1	3	0	4	0	1	0	0	1	1	3	0	0	4	1	11	0	0	12	21
1500-1600	0	3	2	0	5	1	0	0	0	1	0	8	0	0	8	2	10	0	0	12	26
1600-1700	1	1	6	0	8	1	0	0	0	1	0	16	0	0	16	1	17	0	0	18	43
1700-1800	3	3	4	0	10	2	2	1	0	5	1	8	0	1	10	0	9	2	0	11	36
<b>Totals</b>	<b>6</b>	<b>10</b>	<b>20</b>	<b>0</b>	<b>36</b>	<b>5</b>	<b>6</b>	<b>4</b>	<b>0</b>	<b>15</b>	<b>2</b>	<b>59</b>	<b>1</b>	<b>1</b>	<b>63</b>	<b>5</b>	<b>68</b>	<b>2</b>	<b>0</b>	<b>75</b>	<b>189</b>

**Comments:**  
OC Transpo and Para Transpo buses, private buses and school buses comprise 49.08% of the heavy vehicle traffic. The bicycle totals include 26 E-scooters (both stand-up type and Vespa style). The pedestrian crossing totals include 11 pedestrians with accessibility issues using either a cane, walker or electric wheelchair. Many pedestrians and cyclists either cross or drive through the intersection on a red signal.



### Turning Movement Count Pedestrian Crossings Summary and Flow Diagram



#### Elgin Street & Nepean Street Ottawa, ON

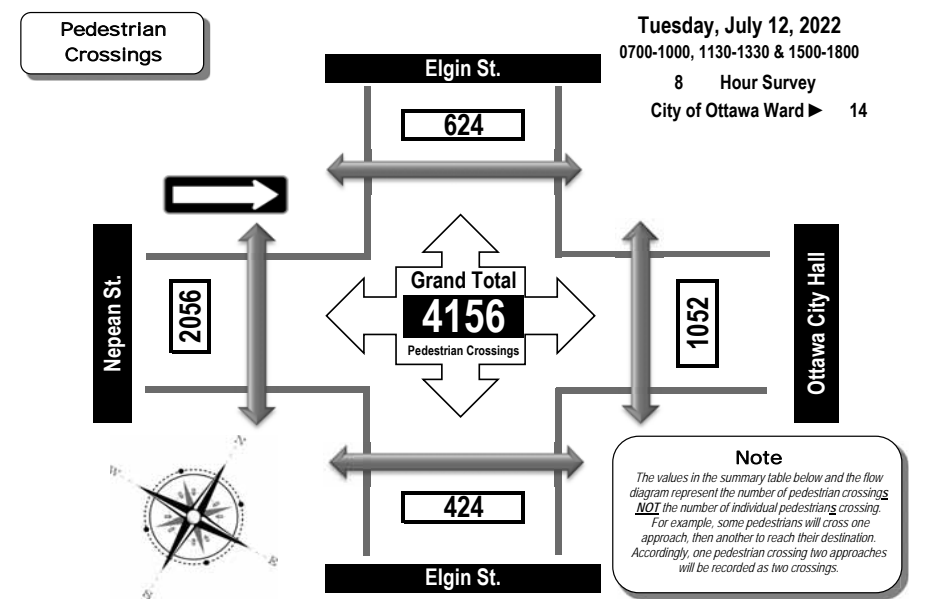

Time Period	West Side Crossing Nepean St.	East Side Crossing Ottawa City Hall	Street Total	South Side Crossing Elgin St.	North Side Crossing Elgin St.	Street Total	Grand Total
0700-0800	83	42	125	29	33	62	187
0800-0900	191	100	291	31	73	104	395
0900-1000	145	120	265	40	66	106	371
1130-1230	353	139	492	56	103	159	651
1230-1330	378	180	558	93	126	219	777
1500-1600	225	132	357	53	57	110	467
1600-1700	322	172	494	71	88	159	653
1700-1800	359	167	526	51	78	129	655
<b>Totals</b>	<b>2056</b>	<b>1052</b>	<b>3108</b>	<b>424</b>	<b>624</b>	<b>1048</b>	<b>4156</b>

**Comments:**  
OC Transpo and Para Transpo buses, private buses and school buses comprise 49.08% of the heavy vehicle traffic. The bicycle totals include 26 E-scooters (both stand-up type and Vespa style). The pedestrian crossing totals include 11 pedestrians with accessibility issues using either a cane, walker or electric wheelchair. Many pedestrians and cyclists either cross or drive through the intersection on a red signal.



# Transportation Services - Traffic Services

## Turning Movement Count - Study Results

### ELGIN ST @ LAURIER AVE

Survey Date: Wednesday, February 27, 2019

WO No: 38383

Start Time: 07:00

Device: Miovision

#### Full Study Diagram

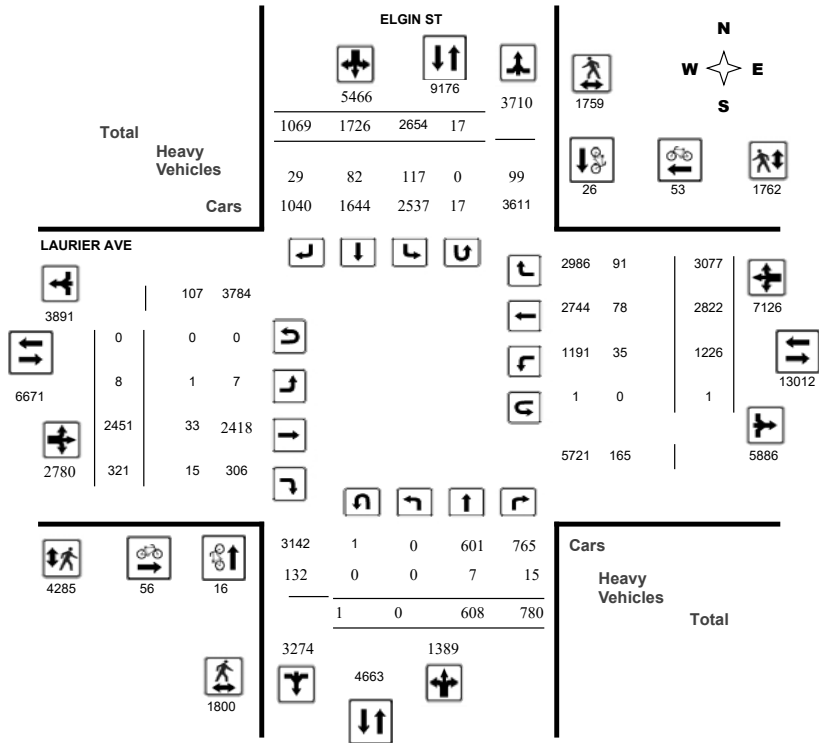

# Transportation Services - Traffic Services

## Turning Movement Count - Study Results

### ELGIN ST @ LAURIER AVE

Survey Date: Wednesday, February 27, 2019

WO No: 38383

Start Time: 07:00

Device: Miovision

#### Full Study Peak Hour Diagram

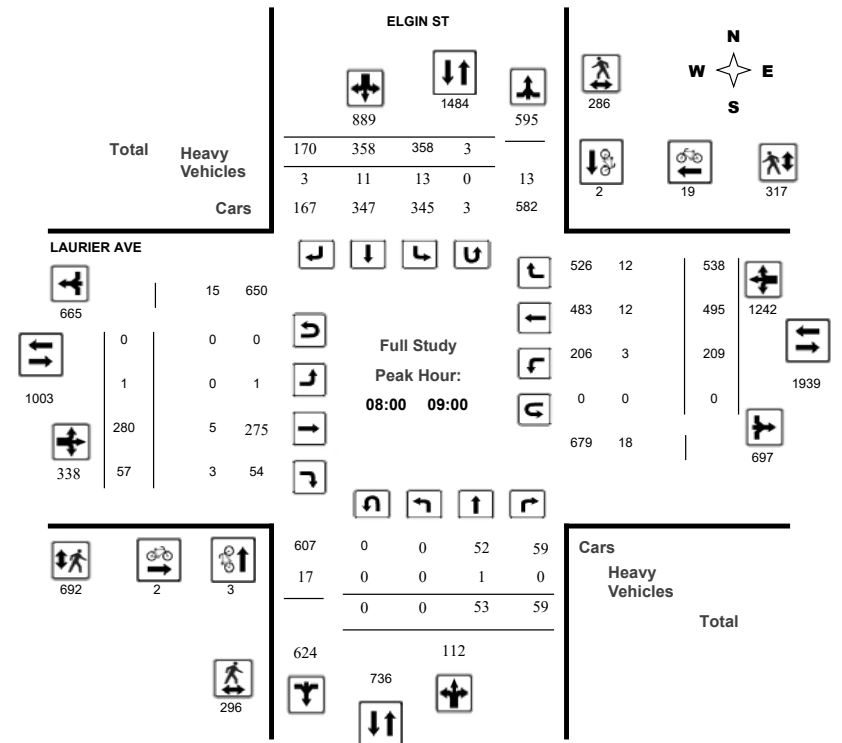



# Transportation Services - Traffic Services

## Turning Movement Count - Peak Hour Diagram

### ELGIN ST @ LAURIER AVE

Survey Date: Wednesday, February 27, 2019  
Start Time: 07:00

WO No: 38383  
Device: Miovision

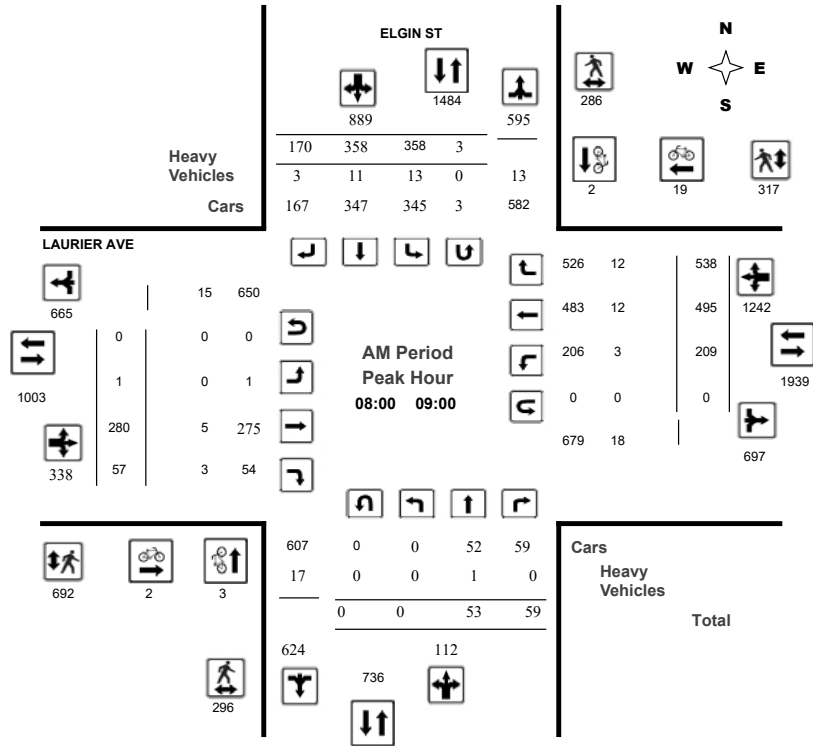

# Transportation Services - Traffic Services

## Turning Movement Count - Peak Hour Diagram

### ELGIN ST @ LAURIER AVE

Survey Date: Wednesday, February 27, 2019  
Start Time: 07:00

WO No: 38383  
Device: Miovision

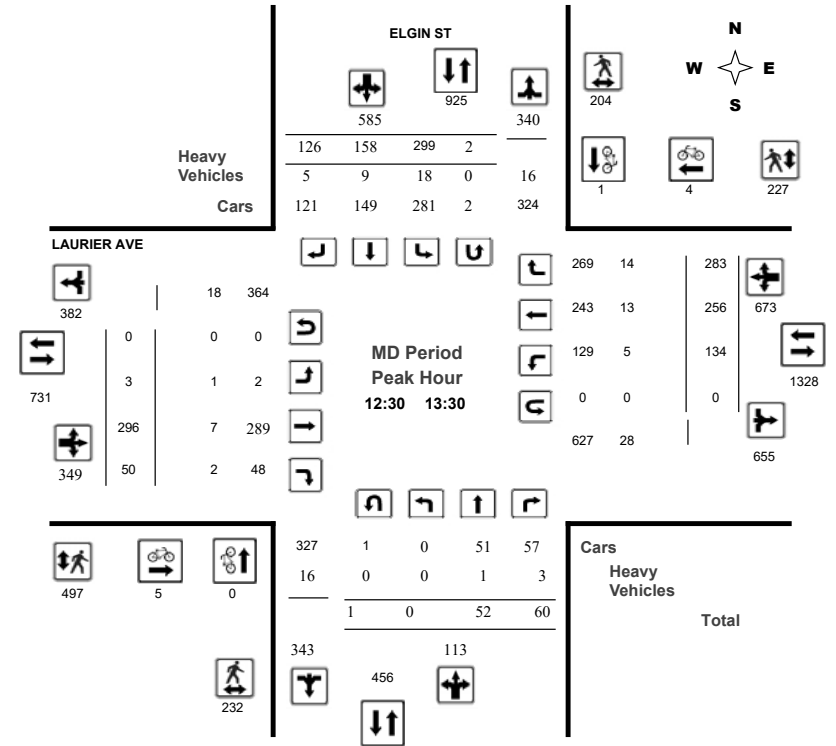



**Transportation Services - Traffic Services**  
**Turning Movement Count - Peak Hour Diagram**  
**ELGIN ST @ LAURIER AVE**

Survey Date: Wednesday, February 27, 2019  
 Start Time: 07:00

WO No: 38383  
 Device: Miovision

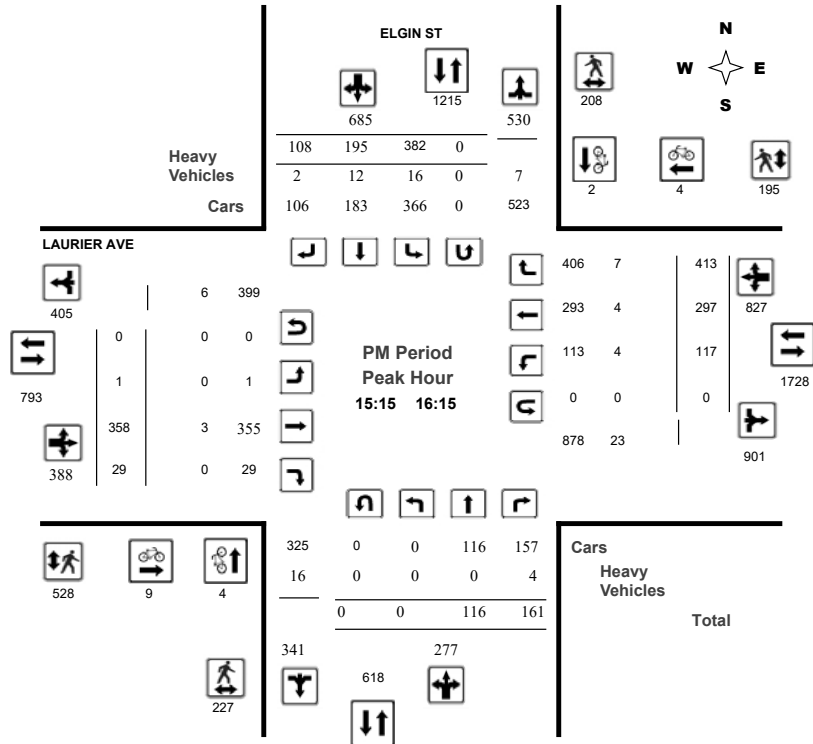

Comments



**Transportation Services - Traffic Services**  
**Turning Movement Count - Study Results**  
**ELGIN ST @ LAURIER AVE**

Survey Date: Wednesday, February 27, 2019  
 Start Time: 07:00

WO No: 38383  
 Device: Miovision

**Full Study Summary (8 HR Standard)**

Survey Date: Wednesday, February 27, 2019

Total Observed U-Turns  
 Northbound: 1 Southbound: 17  
 Eastbound: 0 Westbound: 1

AADT Factor  
 1.00

Period	ELGIN ST				LAURIER AVE				WB TOT	STR TOT	Grand Total								
	Northbound		Southbound		Eastbound		Westbound												
	LT	ST	RT	NB TOT	LT	ST	RT	SB TOT	STR TOT	LT	ST	RT	EB TOT	LT	ST	RT	WB TOT	STR TOT	Grand Total
07:00-08:00	0	45	56	101	274	227	138	639	740	0	260	40	300	188	484	470	1142	1442	2182
08:00-09:00	0	53	59	112	358	358	170	886	998	1	280	57	338	209	495	538	1242	1580	2578
09:00-10:00	0	45	70	115	285	277	170	732	847	1	273	61	335	200	418	445	1063	1398	2245
11:30-12:30	0	51	69	120	299	177	116	592	712	1	257	41	299	131	310	258	699	998	1710
12:30-13:30	0	52	60	112	299	158	126	583	695	3	296	50	349	134	256	283	673	1022	1717
15:00-16:00	0	102	148	250	402	184	99	685	935	1	377	29	407	130	294	367	791	1198	2133
16:00-17:00	0	158	172	330	343	184	123	650	980	1	366	19	386	109	288	390	787	1173	2153
17:00-18:00	0	102	146	248	394	161	127	682	930	0	342	24	366	125	277	326	728	1094	2024
<b>Sub Total</b>	<b>0</b>	<b>608</b>	<b>780</b>	<b>1388</b>	<b>2654</b>	<b>1726</b>	<b>1069</b>	<b>5449</b>	<b>6837</b>	<b>8</b>	<b>2451</b>	<b>321</b>	<b>2780</b>	<b>1226</b>	<b>2822</b>	<b>3077</b>	<b>7125</b>	<b>9905</b>	<b>16742</b>
<b>U Turns</b>	<b>1</b>			<b>1</b>	<b>17</b>			<b>17</b>	<b>18</b>	<b>0</b>			<b>0</b>	<b>1</b>			<b>1</b>	<b>1</b>	<b>19</b>
<b>Total</b>	<b>1</b>	<b>608</b>	<b>780</b>	<b>1389</b>	<b>2671</b>	<b>1726</b>	<b>1069</b>	<b>5466</b>	<b>6855</b>	<b>8</b>	<b>2451</b>	<b>321</b>	<b>2780</b>	<b>1227</b>	<b>2822</b>	<b>3077</b>	<b>7126</b>	<b>9906</b>	<b>16761</b>
<b>EQ 12Hr</b>	<b>1</b>	<b>845</b>	<b>1084</b>	<b>1930</b>	<b>3713</b>	<b>2399</b>	<b>1486</b>	<b>7598</b>	<b>9528</b>	<b>11</b>	<b>3407</b>	<b>446</b>	<b>3864</b>	<b>1706</b>	<b>3923</b>	<b>4277</b>	<b>9906</b>	<b>13770</b>	<b>23298</b>
Note: These values are calculated by multiplying the totals by the appropriate expansion factor.																	<b>1.39</b>		
<b>AVG 12Hr</b>	<b>1</b>	<b>845</b>	<b>1084</b>	<b>1930</b>	<b>3713</b>	<b>2399</b>	<b>1486</b>	<b>7598</b>	<b>9528</b>	<b>11</b>	<b>3407</b>	<b>446</b>	<b>3864</b>	<b>1706</b>	<b>3923</b>	<b>4277</b>	<b>9906</b>	<b>13770</b>	<b>23298</b>
Note: These volumes are calculated by multiplying the Equivalent 12 hr. totals by the AADT factor.																	<b>1.00</b>		
<b>AVG 24Hr</b>	<b>1</b>	<b>1107</b>	<b>1420</b>	<b>2528</b>	<b>4864</b>	<b>3143</b>	<b>1947</b>	<b>9954</b>	<b>12482</b>	<b>14</b>	<b>4463</b>	<b>584</b>	<b>5061</b>	<b>2235</b>	<b>5139</b>	<b>5603</b>	<b>12977</b>	<b>18038</b>	<b>30520</b>
Note: These volumes are calculated by multiplying the Average Daily 12 hr. totals by 12 to 24 expansion factor.																	<b>1.31</b>		
Note: U-Turns provided for approach totals. Refer to 'U-Turn' Report for specific breakdown.																			





Transportation Services - Traffic Services

Turning Movement Count - Study Results

ELGIN ST @ LAURIER AVE

Survey Date: Wednesday, February 27, 2019

WO No: 38383

Start Time: 07:00

Device: Miovision

Full Study Cyclist Volume

Time Period	ELGIN ST			LAURIER AVE			Grand Total
	Northbound	Southbound	Street Total	Eastbound	Westbound	Street Total	
07:00 07:15	0	0	0	0	1	1	1
07:15 07:30	0	0	0	0	3	3	3
07:30 07:45	0	0	0	0	2	2	2
07:45 08:00	0	2	2	2	1	3	5
08:00 08:15	1	0	1	1	7	8	9
08:15 08:30	1	2	3	0	7	7	10
08:30 08:45	1	0	1	1	3	4	5
08:45 09:00	0	0	0	0	2	2	2
09:00 09:15	0	2	2	1	2	3	5
09:15 09:30	0	1	1	2	1	3	4
09:30 09:45	1	3	4	3	2	5	9
09:45 10:00	1	0	1	1	1	2	3
11:30 11:45	0	0	0	0	0	0	0
11:45 12:00	0	0	0	1	2	3	3
12:00 12:15	0	1	1	2	2	4	5
12:15 12:30	0	0	0	1	0	1	1
12:30 12:45	0	0	0	2	1	3	3
12:45 13:00	0	1	1	1	0	1	2
13:00 13:15	0	0	0	1	3	4	4
13:15 13:30	0	0	0	1	0	1	1
15:00 15:15	0	2	2	1	0	1	3
15:15 15:30	3	0	3	2	0	2	5
15:30 15:45	1	0	1	6	2	8	9
15:45 16:00	0	2	2	0	2	2	4
16:00 16:15	0	0	0	1	0	1	1
16:15 16:30	1	0	1	3	1	4	5
16:30 16:45	1	0	1	3	0	3	4
16:45 17:00	1	0	1	8	1	9	10
17:00 17:15	0	2	2	3	2	5	7
17:15 17:30	4	5	9	4	4	8	17
17:30 17:45	0	1	1	2	0	2	3
17:45 18:00	0	2	2	3	1	4	6
Total	16	26	42	56	53	109	151



Transportation Services - Traffic Services

Turning Movement Count - Study Results

ELGIN ST @ LAURIER AVE

Survey Date: Wednesday, February 27, 2019

WO No: 38383

Start Time: 07:00

Device: Miovision

Full Study Pedestrian Volume

Time Period	ELGIN ST			LAURIER AVE			Grand Total
	NB Approach (E or W Crossing)	SB Approach (E or W Crossing)	Total	EB Approach (N or S Crossing)	WB Approach (N or S Crossing)	Total	
07:00 07:15	17	25	42	64	17	81	123
07:15 07:30	23	19	42	90	10	100	142
07:30 07:45	41	45	86	129	32	161	247
07:45 08:00	67	46	113	137	49	186	299
08:00 08:15	63	51	114	148	54	202	316
08:15 08:30	67	68	135	174	90	264	399
08:30 08:45	74	81	155	184	93	277	432
08:45 09:00	92	86	178	186	80	266	444
09:00 09:15	65	61	126	140	62	202	328
09:15 09:30	49	42	91	101	60	161	252
09:30 09:45	51	25	76	80	42	122	198
09:45 10:00	37	29	66	74	39	113	179
11:30 11:45	52	35	87	91	34	125	212
11:45 12:00	54	51	105	130	43	173	278
12:00 12:15	56	68	124	136	59	195	319
12:15 12:30	61	68	129	165	58	223	352
12:30 12:45	59	45	104	139	57	196	300
12:45 13:00	61	72	133	134	59	193	326
13:00 13:15	58	52	110	118	53	171	281
13:15 13:30	54	35	89	106	58	164	253
15:00 15:15	45	29	74	62	40	102	176
15:15 15:30	57	55	112	120	39	159	271
15:30 15:45	49	40	89	105	42	147	236
15:45 16:00	51	56	107	126	59	185	292
16:00 16:15	70	57	127	177	55	232	359
16:15 16:30	61	67	128	164	61	225	353
16:30 16:45	63	95	158	179	64	243	401
16:45 17:00	52	88	140	168	72	240	380
17:00 17:15	68	101	169	202	80	282	451
17:15 17:30	59	68	127	169	80	249	376
17:30 17:45	67	49	116	178	64	242	358
17:45 18:00	57	50	107	109	57	166	273
Total	1800	1759	3559	4285	1762	6047	9606



### Transportation Services - Traffic Services

#### Turning Movement Count - Study Results

##### ELGIN ST @ LAURIER AVE

Survey Date: Wednesday, February 27, 2019

WO No: 38383

Start Time: 07:00

Device: Miovision

#### Full Study Heavy Vehicles

		ELGIN ST				LAURIER AVE														
		Northbound		Southbound		Eastbound		Westbound												
Time Period		LT	ST	RT	N TOT	LT	ST	RT	S TOT	STR TOT	LT	ST	RT	E TOT	LT	ST	RT	W TOT	STR TOT	Grand Total
07:00	07:15	0	1	0		3	3	2		9	0	2	0		2	3	5		12	21
07:15	07:30	0	1	0		5	3	0		9	0	1	0		1	2	3		7	16
07:30	07:45	0	0	0		2	2	0		4	0	2	0		1	3	2		8	12
07:45	08:00	0	0	1		6	1	1		9	0	1	2		3	2	4		12	21
08:00	08:15	0	1	0		5	3	0		9	0	1	1		1	3	5		11	20
08:15	08:30	0	0	0		3	3	1		7	0	1	1		1	2	1		6	13
08:30	08:45	0	0	0		2	1	1		4	0	1	0		0	0	2		3	7
08:45	09:00	0	0	0		3	4	1		8	0	2	1		1	7	4		15	23
09:00	09:15	0	1	1		8	3	1		14	0	1	1		2	6	10		20	34
09:15	09:30	0	0	0		2	4	0		6	0	1	1		2	4	5		13	19
09:30	09:45	0	1	1		3	6	3		14	0	1	1		1	3	6		12	26
09:45	10:00	0	0	1		4	3	2		10	0	2	2		3	4	3		14	24
11:30	11:45	0	0	0		2	3	1		6	0	0	0		2	3	2		7	13
11:45	12:00	0	0	0		5	1	2		8	0	2	1		1	5	1		10	18
12:00	12:15	0	0	0		5	1	2		8	0	2	1		1	3	0		7	15
12:15	12:30	0	1	0		4	2	2		9	0	1	0		1	3	4		9	18
12:30	12:45	0	0	1		4	2	4		11	1	2	0		0	0	2		5	16
12:45	13:00	0	1	1		5	2	0		9	0	1	1		0	3	3		8	17
13:00	13:15	0	0	0		4	4	0		8	0	2	1		3	5	3		14	22
13:15	13:30	0	0	1		5	1	1		8	0	2	0		2	5	6		15	23
15:00	15:15	0	0	0		6	2	0		8	0	1	0		3	0	3		7	15
15:15	15:30	0	0	2		6	4	1		13	0	0	0		4	0	2		6	19
15:30	15:45	0	0	1		2	2	1		6	0	1	0		0	3	4		8	14
15:45	16:00	0	0	1		3	3	0		7	0	0	0		0	1	1		2	9
16:00	16:15	0	0	0		5	3	0		8	0	2	0		0	0	0		2	10
16:15	16:30	0	0	0		5	3	2		10	0	1	0		0	1	4		6	16
16:30	16:45	0	0	3		2	1	1		7	0	0	1		0	1	1		3	10
16:45	17:00	0	0	0		4	2	0		6	0	0	0		0	4	3		7	13
17:00	17:15	0	0	1		1	2	0		4	0	0	0		0	0	2		2	6
17:15	17:30	0	0	0		2	4	0		6	0	0	0		0	0	0		0	6
17:30	17:45	0	0	0		1	3	0		4	0	0	0		0	1	0		1	5
17:45	18:00	0	0	0		0	1	0		1	0	0	0		0	1	0		1	2
Total:	None	0	7	15	0	117	82	29	0	250	1	33	15	0	35	78	91	0	253	503



### Transportation Services - Traffic Services

#### Turning Movement Count - Study Results

##### ELGIN ST @ LAURIER AVE

Survey Date: Wednesday, February 27, 2019

WO No: 38383

Start Time: 07:00

Device: Miovision

#### Full Study 15 Minute U-Turn Total

		ELGIN ST		LAURIER AVE			
		Northbound	Southbound	Eastbound	Westbound		
Time Period		U-Turn Total	U-Turn Total	U-Turn Total	U-Turn Total	Total	
07:00	07:15	0	0	0	0	0	
07:15	07:30	0	0	0	0	0	
07:30	07:45	0	0	0	0	0	
07:45	08:00	0	0	0	0	0	
08:00	08:15	0	0	0	0	0	
08:15	08:30	0	0	0	0	0	
08:30	08:45	0	1	0	0	1	
08:45	09:00	0	2	0	0	2	
09:00	09:15	0	1	0	1	2	
09:15	09:30	0	2	0	0	2	
09:30	09:45	0	0	0	0	0	
09:45	10:00	0	2	0	0	2	
11:30	11:45	0	1	0	0	1	
11:45	12:00	0	2	0	0	2	
12:00	12:15	0	1	0	0	1	
12:15	12:30	0	0	0	0	0	
12:30	12:45	1	0	0	0	1	
12:45	13:00	0	0	0	0	0	
13:00	13:15	0	1	0	0	1	
13:15	13:30	0	0	0	0	0	
15:00	15:15	0	0	0	0	0	
15:15	15:30	0	0	0	0	0	
15:30	15:45	0	0	0	0	0	
15:45	16:00	0	0	0	0	0	
16:00	16:15	0	0	0	0	0	
16:15	16:30	0	0	0	0	0	
16:30	16:45	0	0	0	0	0	
16:45	17:00	0	0	0	0	0	
17:00	17:15	0	2	0	0	2	
17:15	17:30	0	0	0	0	0	
17:30	17:45	0	0	0	0	0	
17:45	18:00	0	1	0	0	1	
Total		1	17	0	1	19	



# Transportation Services - Traffic Services

## Turning Movement Count - Study Results

### GLoucester St @ Metcalfe St

Survey Date: Tuesday, April 04, 2017  
Start Time: 07:00

WO No: 36839  
Device: Miovision

#### Full Study Diagram

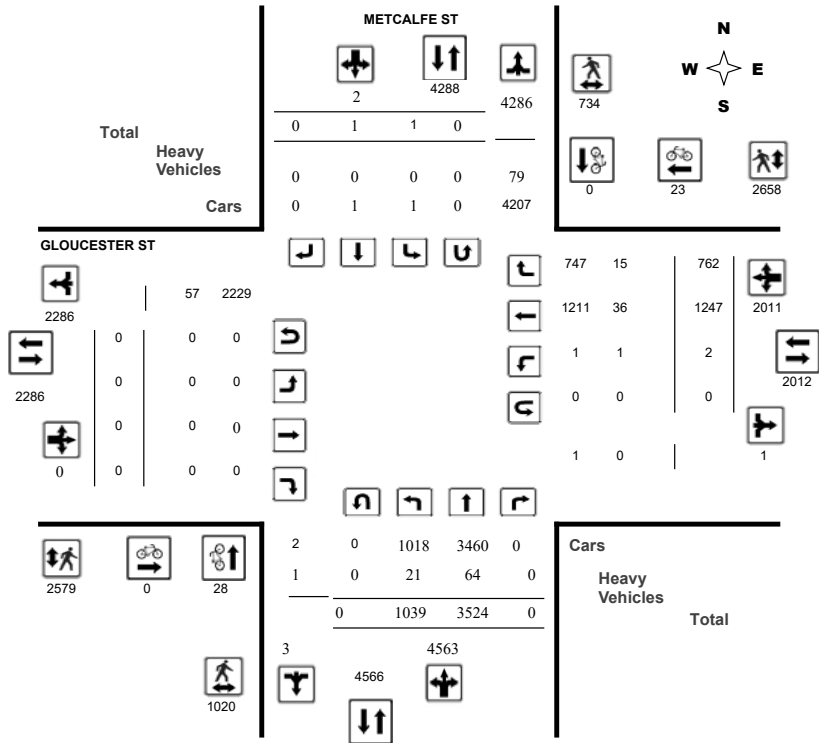





# Transportation Services - Traffic Services

## Turning Movement Count - Peak Hour Diagram

### GLOUCESTER ST @ METCALFE ST

Survey Date: Tuesday, April 04, 2017  
Start Time: 07:00

WO No: 36839  
Device: Miovision

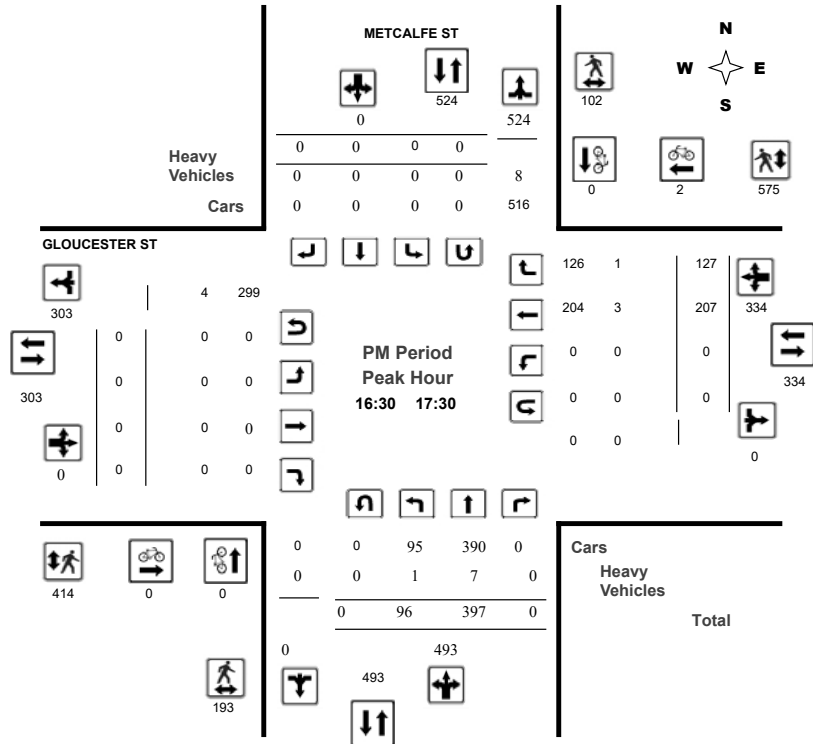

Comments



# Transportation Services - Traffic Services

## Turning Movement Count - Study Results

### GLOUCESTER ST @ METCALFE ST

Survey Date: Tuesday, April 04, 2017  
Start Time: 07:00

WO No: 36839  
Device: Miovision

### Full Study Summary (8 HR Standard)

Survey Date: Tuesday, April 04, 2017

Total Observed U-Turns		AADT Factor
Northbound: 0	Southbound: 0	.90
Eastbound: 0	Westbound: 0	

Period	METCALFE ST								GLOUCESTER ST								WB TOT	STR TOT	Grand Total
	Northbound				Southbound				Eastbound				Westbound						
	LT	ST	RT	NB TOT	LT	ST	RT	SB TOT	STR TOT	LT	ST	RT	EB TOT	LT	ST	RT			
07:00-08:00	190	556	0	746	1	0	0	1	747	0	0	0	0	0	130	64	194	194	941
08:00-09:00	223	720	0	943	0	0	0	0	943	0	0	0	0	0	162	74	236	236	1179
09:00-10:00	161	518	0	679	0	0	0	0	679	0	0	0	0	1	166	88	255	255	934
11:30-12:30	109	326	0	435	0	0	0	0	435	0	0	0	0	0	107	79	186	186	621
12:30-13:30	93	334	0	427	0	1	0	1	428	0	0	0	0	0	125	83	208	208	636
15:00-16:00	84	303	0	387	0	0	0	0	387	0	0	0	0	1	165	114	280	280	667
16:00-17:00	91	376	0	467	0	0	0	0	467	0	0	0	0	0	190	146	336	336	803
17:00-18:00	88	391	0	479	0	0	0	0	479	0	0	0	0	0	202	114	316	316	795
<b>Sub Total</b>	1039	3524	0	4563	1	1	0	2	4565	0	0	0	0	2	1247	762	2011	2011	6576
<b>U Turns</b>	0	0	0	0	0	0	0	0	0	0	0	0	0	0	0	0	0	0	0
<b>Total</b>	1039	3524	0	4563	1	1	0	2	4565	0	0	0	0	2	1247	762	2011	2011	6576
<b>EQ 12Hr</b>	1444	4898	0	6342	1	1	0	2	6344	0	0	0	0	3	1733	1059	2795	2795	9139
Note: These values are calculated by multiplying the totals by the appropriate expansion factor.											<b>1.39</b>								
<b>AVG 12Hr</b>	1300	4408	0	5708	1	1	0	2	5710	0	0	0	0	3	1560	953	2516	2516	8226
Note: These volumes are calculated by multiplying the Equivalent 12 hr. totals by the AADT factor.											<b>.90</b>								
<b>AVG 24Hr</b>	1703	5774	0	7477	1	1	0	2	7479	0	0	0	0	4	2044	1248	3296	3296	10775
Note: These volumes are calculated by multiplying the Average Daily 12 hr. totals by 12 to 24 expansion factor.											<b>1.31</b>								
Note: U-Turns provided for approach totals. Refer to 'U-Turn' Report for specific breakdown.																			



Transportation Services - Traffic Services

Turning Movement Count - Study Results

GLOUCESTER ST @ METCALFE ST

Survey Date: Tuesday, April 04, 2017

WO No: 36839

Start Time: 07:00

Device: Miovision

Full Study Cyclist Volume

Time Period	METCALFE ST			GLOUCESTER ST			Grand Total
	Northbound	Southbound	Street Total	Eastbound	Westbound	Street Total	
07:00 07:15	1	0	1	0	0	0	1
07:15 07:30	0	0	0	0	1	1	1
07:30 07:45	2	0	2	0	0	0	2
07:45 08:00	0	0	0	0	0	0	0
08:00 08:15	2	0	2	0	0	0	2
08:15 08:30	4	0	4	0	0	0	4
08:30 08:45	0	0	0	0	0	0	0
08:45 09:00	5	0	5	0	1	1	6
09:00 09:15	0	0	0	0	2	2	2
09:15 09:30	3	0	3	0	0	0	3
09:30 09:45	0	0	0	0	0	0	0
09:45 10:00	1	0	1	0	0	0	1
11:30 11:45	0	0	0	0	0	0	0
11:45 12:00	0	0	0	0	1	1	1
12:00 12:15	0	0	0	0	3	3	3
12:15 12:30	0	0	0	0	2	2	2
12:30 12:45	0	0	0	0	1	1	1
12:45 13:00	2	0	2	0	0	0	2
13:00 13:15	0	0	0	0	0	0	0
13:15 13:30	2	0	2	0	0	0	2
15:00 15:15	1	0	1	0	1	1	2
15:15 15:30	1	0	1	0	1	1	2
15:30 15:45	2	0	2	0	1	1	3
15:45 16:00	1	0	1	0	2	2	3
16:00 16:15	0	0	0	0	0	0	0
16:15 16:30	0	0	0	0	3	3	3
16:30 16:45	0	0	0	0	2	2	2
16:45 17:00	0	0	0	0	0	0	0
17:00 17:15	0	0	0	0	0	0	0
17:15 17:30	0	0	0	0	0	0	0
17:30 17:45	0	0	0	0	2	2	2
17:45 18:00	1	0	1	0	0	0	1
Total	28	0	28	0	23	23	51



Transportation Services - Traffic Services

Turning Movement Count - Study Results

GLOUCESTER ST @ METCALFE ST

Survey Date: Tuesday, April 04, 2017

WO No: 36839

Start Time: 07:00

Device: Miovision

Full Study Pedestrian Volume

Time Period	METCALFE ST			GLOUCESTER ST			Grand Total
	NB Approach (E or W Crossing)	SB Approach (E or W Crossing)	Total	EB Approach (N or S Crossing)	WB Approach (N or S Crossing)	Total	
07:00 07:15	11	14	25	45	55	100	125
07:15 07:30	18	19	37	59	57	116	153
07:30 07:45	27	12	39	86	73	159	198
07:45 08:00	32	22	54	105	93	198	252
08:00 08:15	34	29	63	96	110	206	269
08:15 08:30	43	33	76	128	95	223	299
08:30 08:45	42	53	95	142	101	243	338
08:45 09:00	49	43	92	157	115	272	364
09:00 09:15	39	27	66	91	65	156	222
09:15 09:30	25	27	52	85	75	160	212
09:30 09:45	15	19	34	70	59	129	163
09:45 10:00	16	16	32	46	48	94	126
11:30 11:45	24	10	34	38	58	96	130
11:45 12:00	29	28	57	47	50	97	154
12:00 12:15	30	25	55	59	65	124	179
12:15 12:30	28	19	47	66	61	127	174
12:30 12:45	35	21	56	88	44	132	188
12:45 13:00	27	20	47	77	42	119	166
13:00 13:15	40	31	71	80	54	134	205
13:15 13:30	28	16	44	54	54	108	152
15:00 15:15	30	15	45	71	50	121	166
15:15 15:30	38	16	54	47	66	113	167
15:30 15:45	32	12	44	57	69	126	170
15:45 16:00	25	11	36	61	81	142	178
16:00 16:15	31	20	51	70	162	232	283
16:15 16:30	28	30	58	76	104	180	238
16:30 16:45	48	26	74	114	139	253	327
16:45 17:00	38	25	63	93	121	214	277
17:00 17:15	56	29	85	101	168	269	354
17:15 17:30	51	22	73	106	147	253	326
17:30 17:45	33	26	59	77	91	168	227
17:45 18:00	18	18	36	87	86	173	209
Total	1020	734	1754	2579	2658	5237	6991



Transportation Services - Traffic Services

Turning Movement Count - Study Results

GLOUCESTER ST @ METCALFE ST

Survey Date: Tuesday, April 04, 2017

WO No: 36839

Start Time: 07:00

Device: Miovision

Full Study Heavy Vehicles

METCALFE ST				GLOUCESTER ST																
		Northbound		Southbound		Eastbound		Westbound												
Time Period	LT	ST	RT	N TOT	LT	ST	RT	S TOT	STR TOT	LT	ST	RT	E TOT	LT	ST	RT	W TOT	STR TOT	Grand Total	
07:00	07:15	0	0	0	0	0	0	0	0	0	0	0	0	0	1	0	0	1	1	1
07:15	07:30	0	1	0	0	0	0	0	1	0	0	0	0	0	1	0	0	1	1	2
07:30	07:45	1	2	0	0	0	0	0	3	0	0	0	0	0	3	0	0	3	3	6
07:45	08:00	1	2	0	0	0	0	0	3	0	0	0	0	0	1	0	0	1	4	4
08:00	08:15	1	4	0	0	0	0	0	5	0	0	0	0	0	2	0	0	2	7	7
08:15	08:30	5	1	0	0	0	0	0	6	0	0	0	0	0	1	1	0	2	8	8
08:30	08:45	1	3	0	0	0	0	0	4	0	0	0	0	0	4	0	0	4	8	8
08:45	09:00	0	1	0	0	0	0	0	1	0	0	0	0	0	1	0	0	1	2	2
09:00	09:15	0	1	0	0	0	0	0	1	0	0	0	1	3	0	0	0	4	5	5
09:15	09:30	0	3	0	0	0	0	0	3	0	0	0	0	2	1	0	0	3	6	6
09:30	09:45	1	4	0	0	0	0	0	5	0	0	0	0	0	1	0	0	1	6	6
09:45	10:00	2	2	0	0	0	0	0	4	0	0	0	0	2	2	0	0	4	8	8
11:30	11:45	0	2	0	0	0	0	0	2	0	0	0	0	1	0	0	0	1	3	3
11:45	12:00	1	1	0	0	0	0	0	2	0	0	0	0	0	2	0	0	2	4	4
12:00	12:15	0	3	0	0	0	0	0	3	0	0	0	0	1	0	0	0	1	4	4
12:15	12:30	0	2	0	0	0	0	0	2	0	0	0	0	0	0	0	0	0	2	2
12:30	12:45	1	7	0	0	0	0	0	8	0	0	0	0	1	0	0	0	1	9	9
12:45	13:00	2	4	0	0	0	0	0	6	0	0	0	0	3	0	0	0	3	9	9
13:00	13:15	0	4	0	0	0	0	0	4	0	0	0	0	1	0	0	0	1	5	5
13:15	13:30	0	0	0	0	0	0	0	0	0	0	0	0	2	3	0	0	5	5	5
15:00	15:15	1	3	0	0	0	0	0	4	0	0	0	0	2	1	0	0	3	7	7
15:15	15:30	0	2	0	0	0	0	0	2	0	0	0	0	0	0	0	0	0	2	2
15:30	15:45	1	1	0	0	0	0	0	2	0	0	0	0	0	0	0	0	0	2	2
15:45	16:00	0	1	0	0	0	0	0	1	0	0	0	0	1	2	0	0	3	4	4
16:00	16:15	0	3	0	0	0	0	0	3	0	0	0	0	0	1	0	0	1	4	4
16:15	16:30	1	0	0	0	0	0	0	1	0	0	0	0	0	0	0	0	0	1	1
16:30	16:45	1	1	0	0	0	0	0	2	0	0	0	0	0	0	0	0	0	2	2
16:45	17:00	0	2	0	0	0	0	0	2	0	0	0	0	0	0	0	0	0	2	2
17:00	17:15	0	2	0	0	0	0	0	2	0	0	0	0	2	1	0	0	3	5	5
17:15	17:30	0	2	0	0	0	0	0	2	0	0	0	0	1	0	0	0	1	3	3
17:30	17:45	0	0	0	0	0	0	0	0	0	0	0	0	0	0	0	0	0	0	0
17:45	18:00	1	0	0	0	0	0	0	1	0	0	0	0	0	0	0	0	0	1	1
Total:	None	21	64	0	0	0	0	0	85	0	0	0	0	1	36	15	0	52	137	137



Transportation Services - Traffic Services

Turning Movement Count - Study Results

GLOUCESTER ST @ METCALFE ST

Survey Date: Tuesday, April 04, 2017

WO No: 36839

Start Time: 07:00

Device: Miovision

Full Study 15 Minute U-Turn Total

		METCALFE ST		GLOUCESTER ST					
Time Period		Northbound U-Turn Total	Southbound U-Turn Total	Eastbound U-Turn Total	Westbound U-Turn Total	Total			
07:00	07:15	0	0	0	0	0			0
07:15	07:30	0	0	0	0	0			0
07:30	07:45	0	0	0	0	0			0
07:45	08:00	0	0	0	0	0			0
08:00	08:15	0	0	0	0	0			0
08:15	08:30	0	0	0	0	0			0
08:30	08:45	0	0	0	0	0			0
08:45	09:00	0	0	0	0	0			0
09:00	09:15	0	0	0	0	0			0
09:15	09:30	0	0	0	0	0			0
09:30	09:45	0	0	0	0	0			0
09:45	10:00	0	0	0	0	0			0
11:30	11:45	0	0	0	0	0			0
11:45	12:00	0	0	0	0	0			0
12:00	12:15	0	0	0	0	0			0
12:15	12:30	0	0	0	0	0			0
12:30	12:45	0	0	0	0	0			0
12:45	13:00	0	0	0	0	0			0
13:00	13:15	0	0	0	0	0			0
13:15	13:30	0	0	0	0	0			0
13:30	13:45	0	0	0	0	0			0
15:00	15:15	0	0	0	0	0			0
15:15	15:30	0	0	0	0	0			0
15:30	15:45	0	0	0	0	0			0
15:45	16:00	0	0	0	0	0			0
16:00	16:15	0	0	0	0	0			0
16:15	16:30	0	0	0	0	0			0
16:30	16:45	0	0	0	0	0			0
16:45	17:00	0	0	0	0	0			0
17:00	17:15	0	0	0	0	0			0
17:15	17:30	0	0	0	0	0			0
17:30	17:45	0	0	0	0	0			0
17:45	18:00	0	0	0	0	0			0
Total		0	0	0	0	0			0







# Transportation Services - Traffic Services

## Turning Movement Count - Peak Hour Diagram

### LAURIER AVE @ O'CONNOR ST

Survey Date: Tuesday, March 21, 2017  
Start Time: 07:00

WO No: 36788  
Device: Miovision

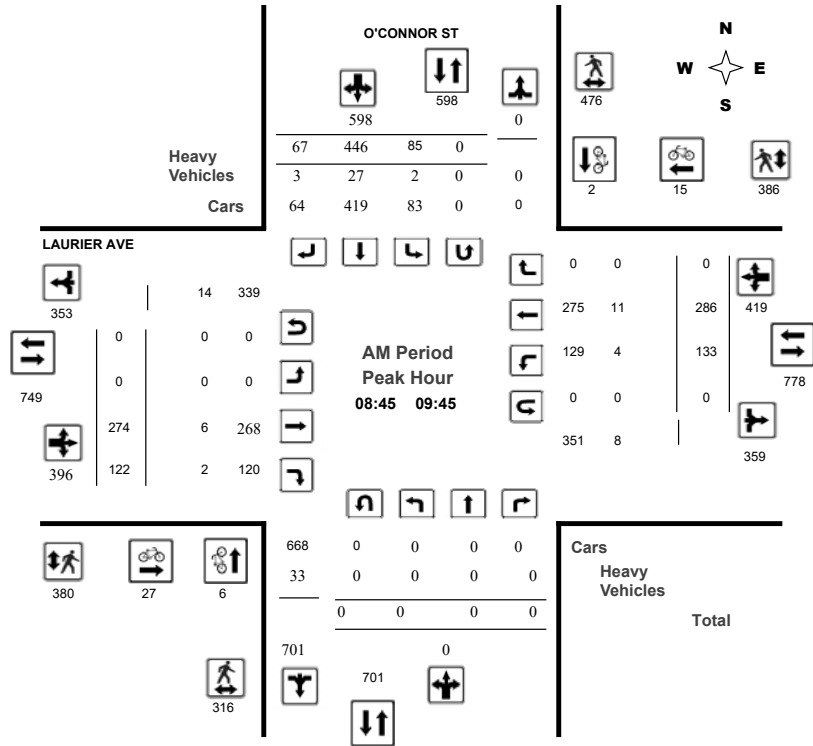

Comments



# Transportation Services - Traffic Services

## Turning Movement Count - Peak Hour Diagram

### LAURIER AVE @ O'CONNOR ST

Survey Date: Tuesday, March 21, 2017  
Start Time: 07:00

WO No: 36788  
Device: Miovision

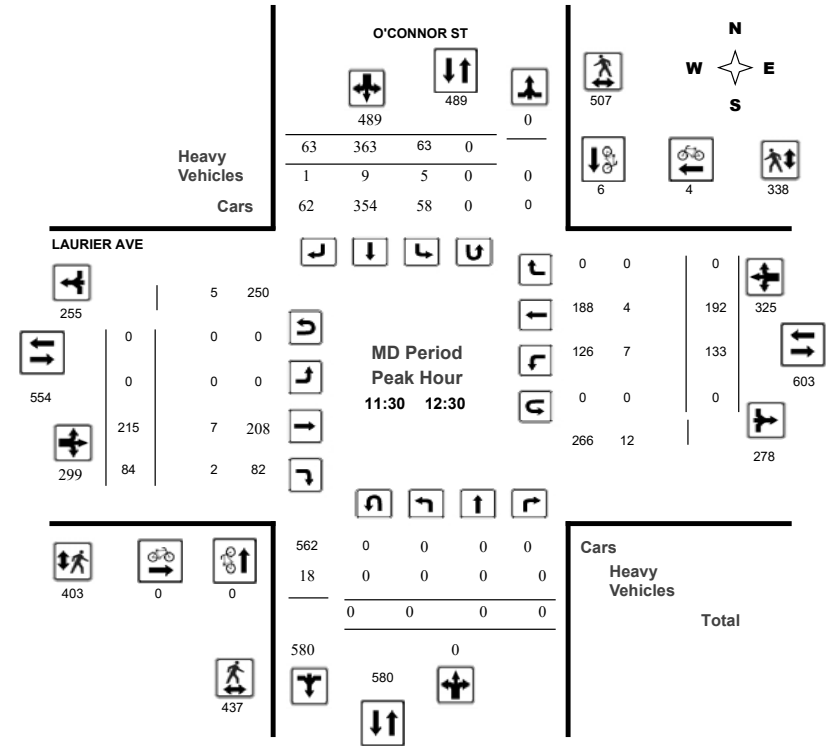

Comments



# Transportation Services - Traffic Services

## Turning Movement Count - Peak Hour Diagram

### LAURIER AVE @ O'CONNOR ST

Survey Date: Tuesday, March 21, 2017  
Start Time: 07:00

WO No: 36788  
Device: Miovision

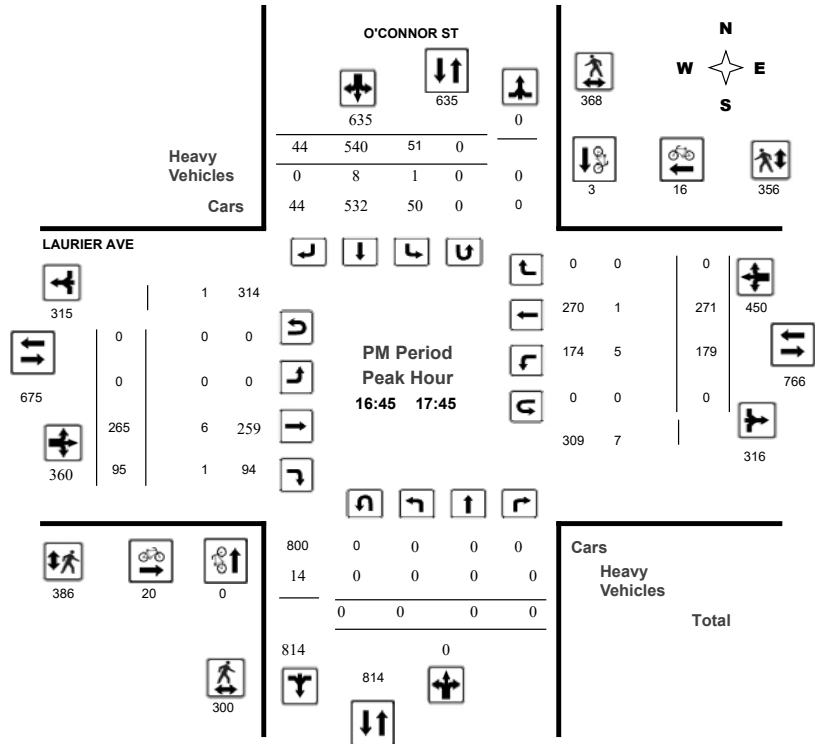

Comments



# Transportation Services - Traffic Services

## Turning Movement Count - Study Results

### LAURIER AVE @ O'CONNOR ST

Survey Date: Tuesday, March 21, 2017  
Start Time: 07:00

WO No: 36788  
Device: Miovision

### Full Study Summary (8 HR Standard)

Survey Date: Tuesday, March 21, 2017

Total Observed U-Turns  
Northbound: 0 Southbound: 0  
Eastbound: 0 Westbound: 0

AADT Factor  
1.00

Period	O'CONNOR ST								LAURIER AVE								WB TOT	STR TOT	Grand Total
	Northbound				Southbound				Eastbound				Westbound						
	LT	ST	RT	NB TOT	LT	ST	RT	SB TOT	LT	ST	RT	EB TOT	LT	ST	RT	WB TOT			
07:00-08:00	0	0	0	0	48	338	45	431	431	0	239	117	356	103	302	0	405	761	1192
08:00-09:00	0	0	0	0	55	380	68	503	503	0	272	126	398	124	294	0	418	816	1319
09:00-10:00	0	0	0	0	86	456	76	618	618	0	257	121	378	137	274	0	411	789	1407
11:30-12:30	0	0	0	0	63	363	63	489	489	0	215	84	299	133	192	0	325	624	1113
12:30-13:30	0	0	0	0	50	320	48	418	418	0	228	87	315	119	180	0	299	614	1032
15:00-16:00	0	0	0	0	65	473	38	576	576	0	265	106	371	154	273	0	427	798	1374
16:00-17:00	0	0	0	0	43	506	43	592	592	0	252	97	349	183	238	0	421	770	1362
17:00-18:00	0	0	0	0	55	522	41	618	618	0	257	84	341	177	273	0	450	791	1409
<b>Sub Total</b>	0	0	0	0	465	3358	422	4245	4245	0	1985	822	2807	1130	2026	0	3156	5963	10208
<b>U Turns</b>	0	0	0	0	0	0	0	0	0	0	0	0	0	0	0	0	0	0	
<b>Total</b>	0	0	0	0	465	3358	422	4245	4245	0	1985	822	2807	1130	2026	0	3156	5963	10208
<b>EQ 12Hr</b>	0	0	0	0	646	4668	587	5901	5901	0	2759	1143	3902	1571	2816	0	4387	8289	14190
Note: These values are calculated by multiplying the totals by the appropriate expansion factor. <b>1.39</b>																			
<b>AVG 12Hr</b>	0	0	0	0	646	4668	587	5901	5901	0	2759	1143	3902	1571	2816	0	4387	8289	14190
Note: These volumes are calculated by multiplying the Equivalent 12 hr. totals by the AADT factor. <b>1.00</b>																			
<b>AVG 24Hr</b>	0	0	0	0	846	6115	769	7730	7730	0	3614	1497	5111	2058	3689	0	5747	10588	18588
Note: These volumes are calculated by multiplying the Average Daily 12 hr. totals by 12 to 24 expansion factor. <b>1.31</b>																			
Note: U-Turns provided for approach totals. Refer to 'U-Turn' Report for specific breakdown.																			



### Transportation Services - Traffic Services

#### Turning Movement Count - Study Results

##### Laurier Ave @ O'Connor St

Survey Date: Tuesday, March 21, 2017

WO No: 36788

Start Time: 07:00

Device: Miovision

#### Full Study Cyclist Volume

Time Period	O'CONNOR ST			LAURIER AVE			Grand Total
	Northbound	Southbound	Street Total	Eastbound	Westbound	Street Total	
07:00 07:15	0	0	0	1	1	2	2
07:15 07:30	1	0	1	2	6	8	9
07:30 07:45	1	0	1	3	1	4	5
07:45 08:00	1	1	2	4	1	5	7
08:00 08:15	1	0	1	4	8	12	13
08:15 08:30	2	0	2	9	10	19	21
08:30 08:45	7	2	9	10	6	16	25
08:45 09:00	0	1	1	16	9	25	26
09:00 09:15	3	1	4	3	1	4	8
09:15 09:30	2	0	2	4	4	8	10
09:30 09:45	1	0	1	4	1	5	6
09:45 10:00	0	1	1	2	5	7	8
11:30 11:45	0	2	2	0	0	0	2
11:45 12:00	0	2	2	0	0	0	2
12:00 12:15	0	2	2	0	1	1	3
12:15 12:30	0	0	0	0	3	3	3
12:30 12:45	1	0	1	4	2	6	7
12:45 13:00	0	0	0	2	0	2	2
13:00 13:15	0	1	1	2	1	3	4
13:15 13:30	0	0	0	2	0	2	2
15:00 15:15	0	1	1	5	0	5	6
15:15 15:30	0	2	2	7	1	8	10
15:30 15:45	0	1	1	4	4	8	9
15:45 16:00	0	1	1	0	4	4	5
16:00 16:15	4	2	6	6	0	6	12
16:15 16:30	0	1	1	5	1	6	7
16:30 16:45	0	2	2	7	0	7	9
16:45 17:00	0	1	1	4	0	4	5
17:00 17:15	0	0	0	7	4	11	11
17:15 17:30	0	0	0	5	3	8	8
17:30 17:45	0	2	2	4	9	13	15
17:45 18:00	0	1	1	5	4	9	10
Total	24	27	51	131	90	221	272



### Transportation Services - Traffic Services

#### Turning Movement Count - Study Results

##### Laurier Ave @ O'Connor St

Survey Date: Tuesday, March 21, 2017

WO No: 36788

Start Time: 07:00

Device: Miovision

#### Full Study Pedestrian Volume

Time Period	O'CONNOR ST			LAURIER AVE			Grand Total
	NB Approach (E or W Crossing)	SB Approach (E or W Crossing)	Total	EB Approach (N or S Crossing)	WB Approach (N or S Crossing)	Total	
07:00 07:15	30	41	71	45	28	73	144
07:15 07:30	58	59	117	59	51	110	227
07:30 07:45	45	64	109	66	62	128	237
07:45 08:00	66	88	154	91	105	196	350
08:00 08:15	84	124	208	119	105	224	432
08:15 08:30	67	131	198	120	132	252	450
08:30 08:45	133	148	281	144	138	282	563
08:45 09:00	120	170	290	113	144	257	547
09:00 09:15	88	110	198	102	108	210	408
09:15 09:30	75	100	175	90	89	179	354
09:30 09:45	33	96	129	75	45	120	249
09:45 10:00	65	63	128	77	58	135	263
11:30 11:45	71	83	154	80	57	137	291
11:45 12:00	116	121	237	101	78	179	416
12:00 12:15	134	156	290	126	116	242	532
12:15 12:30	116	147	263	96	87	183	446
12:30 12:45	121	169	290	124	106	230	520
12:45 13:00	128	148	276	115	122	237	513
13:00 13:15	124	124	248	103	89	192	440
13:15 13:30	93	101	194	88	94	182	376
15:00 15:15	64	97	161	96	69	165	326
15:15 15:30	53	88	141	73	45	118	259
15:30 15:45	64	89	153	77	63	140	293
15:45 16:00	59	121	180	110	77	187	367
16:00 16:15	93	132	225	140	90	230	455
16:15 16:30	75	112	187	112	82	194	381
16:30 16:45	91	131	222	118	94	212	434
16:45 17:00	87	105	192	104	80	184	376
17:00 17:15	84	97	181	113	108	221	402
17:15 17:30	67	86	153	85	95	180	333
17:30 17:45	62	80	142	84	73	157	299
17:45 18:00	61	64	125	84	53	137	262
Total	2627	3445	6072	3130	2743	5873	11945



### Transportation Services - Traffic Services

#### Turning Movement Count - Study Results

#### LAURIER AVE @ O'CONNOR ST

Survey Date: Tuesday, March 21, 2017

WO No: 36788

Start Time: 07:00

Device: Miovision

#### Full Study Heavy Vehicles

O'CONNOR ST LAURIER AVE

Time Period	Northbound			Southbound			Eastbound			Westbound			W TOT	STR TOT	Grand Total					
	LT	ST	RT	N TOT	LT	ST	RT	S TOT	STR TOT	LT	ST	RT				E TOT	LT	ST	RT	
07:00	07:15	0	0	0	0	8	0	8	0	1	1	1	1	0	0	3	11			
07:15	07:30	0	0	0	2	5	0	7	0	3	0	2	3	0	8	15				
07:30	07:45	0	0	0	0	3	0	3	0	0	0	1	2	0	3	6				
07:45	08:00	0	0	0	1	5	0	6	0	1	1	0	1	0	3	9				
08:00	08:15	0	0	0	0	6	0	6	0	2	0	1	3	0	6	12				
08:15	08:30	0	0	0	1	6	0	7	0	1	0	1	3	0	5	12				
08:30	08:45	0	0	0	0	4	1	5	0	1	2	2	1	0	6	11				
08:45	09:00	0	0	0	0	5	1	6	0	2	1	0	4	0	7	13				
09:00	09:15	0	0	0	1	7	0	8	0	3	0	0	3	0	6	14				
09:15	09:30	0	0	0	0	8	1	9	0	1	1	1	3	0	6	15				
09:30	09:45	0	0	0	1	7	1	9	0	0	0	3	1	0	4	13				
09:45	10:00	0	0	0	0	3	1	4	0	2	0	1	3	0	6	10				
11:30	11:45	0	0	0	2	4	1	7	0	0	1	2	2	0	5	12				
11:45	12:00	0	0	0	0	1	0	1	0	3	1	2	2	0	8	9				
12:00	12:15	0	0	0	1	2	0	3	0	1	0	0	0	0	1	4				
12:15	12:30	0	0	0	2	2	0	4	0	3	0	3	0	0	6	10				
12:30	12:45	0	0	0	0	2	0	2	0	2	0	1	2	0	5	7				
12:45	13:00	0	0	0	2	5	0	7	0	1	0	1	3	0	5	12				
13:00	13:15	0	0	0	0	3	1	4	0	4	2	3	2	0	11	15				
13:15	13:30	0	0	0	0	1	1	2	0	3	1	3	3	0	10	12				
15:00	15:15	0	0	0	0	1	1	2	0	0	0	1	2	0	3	5				
15:15	15:30	0	0	0	1	1	0	2	0	1	2	0	2	0	5	7				
15:30	15:45	0	0	0	0	1	0	1	0	0	0	0	2	0	2	3				
15:45	16:00	0	0	0	0	3	0	3	0	1	0	2	4	0	7	10				
16:00	16:15	0	0	0	0	0	0	0	0	2	1	0	0	0	3	3				
16:15	16:30	0	0	0	0	4	0	4	0	2	0	0	1	0	3	7				
16:30	16:45	0	0	0	0	0	0	0	0	0	1	1	2	0	4	4				
16:45	17:00	0	0	0	0	3	0	3	0	0	0	1	1	0	2	5				
17:00	17:15	0	0	0	0	2	0	2	0	1	1	2	0	0	4	6				
17:15	17:30	0	0	0	1	2	0	3	0	1	0	1	0	0	2	5				
17:30	17:45	0	0	0	0	1	0	1	0	4	0	1	0	0	5	6				
17:45	18:00	0	0	0	0	2	0	2	0	0	0	0	0	0	0	2				
Total:	None	0	0	0	0	15	107	9	0	131	0	46	16	0	37	55	0	0	154	285



### Transportation Services - Traffic Services

#### Turning Movement Count - Study Results

#### LAURIER AVE @ O'CONNOR ST

Survey Date: Tuesday, March 21, 2017

WO No: 36788

Start Time: 07:00

Device: Miovision

#### Full Study 15 Minute U-Turn Total

O'CONNOR ST LAURIER AVE

Time Period		Northbound	Southbound	Eastbound	Westbound	Total
		U-Turn Total	U-Turn Total	U-Turn Total	U-Turn Total	
07:00	07:15	0	0	0	0	0
07:15	07:30	0	0	0	0	0
07:30	07:45	0	0	0	0	0
07:45	08:00	0	0	0	0	0
08:00	08:15	0	0	0	0	0
08:15	08:30	0	0	0	0	0
08:30	08:45	0	0	0	0	0
08:45	09:00	0	0	0	0	0
09:00	09:15	0	0	0	0	0
09:15	09:30	0	0	0	0	0
09:30	09:45	0	0	0	0	0
09:45	10:00	0	0	0	0	0
11:30	11:45	0	0	0	0	0
11:45	12:00	0	0	0	0	0
12:00	12:15	0	0	0	0	0
12:15	12:30	0	0	0	0	0
12:30	12:45	0	0	0	0	0
12:45	13:00	0	0	0	0	0
13:00	13:15	0	0	0	0	0
13:15	13:30	0	0	0	0	0
15:00	15:15	0	0	0	0	0
15:15	15:30	0	0	0	0	0
15:30	15:45	0	0	0	0	0
15:45	16:00	0	0	0	0	0
16:00	16:15	0	0	0	0	0
16:15	16:30	0	0	0	0	0
16:30	16:45	0	0	0	0	0
16:45	17:00	0	0	0	0	0
17:00	17:15	0	0	0	0	0
17:15	17:30	0	0	0	0	0
17:30	17:45	0	0	0	0	0
17:45	18:00	0	0	0	0	0
Total		0	0	0	0	0



# Transportation Services - Traffic Services

## Turning Movement Count - Study Results

### METCALFE ST @ LAURIER AVE

Survey Date: Tuesday, April 04, 2017

WO No: 36840

Start Time: 07:00

Device: Miovision

#### Full Study Diagram

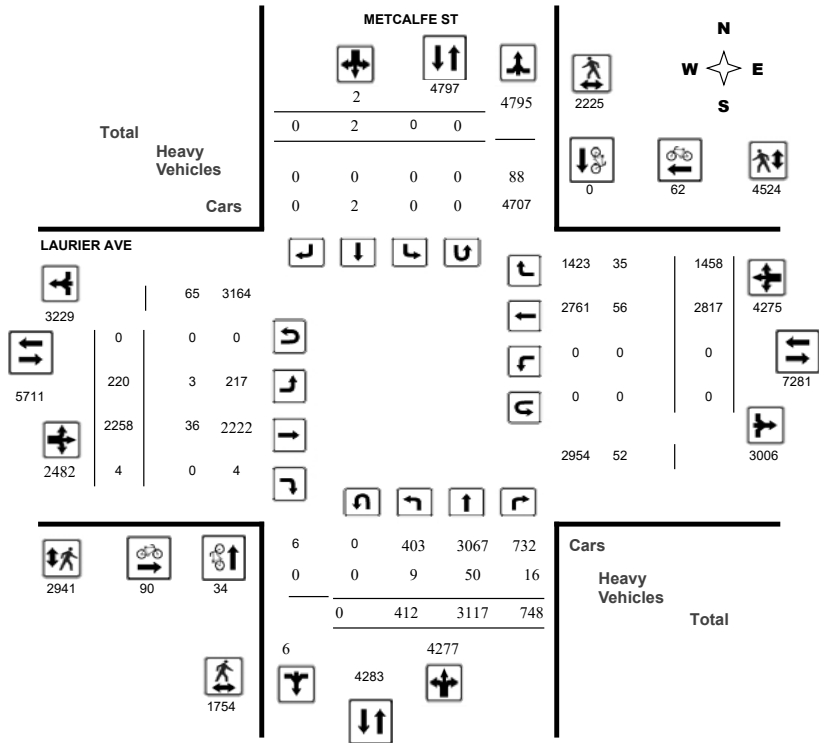

# Transportation Services - Traffic Services

## Turning Movement Count - Study Results

### METCALFE ST @ LAURIER AVE

Survey Date: Tuesday, April 04, 2017

WO No: 36840

Start Time: 07:00

Device: Miovision

#### Full Study Peak Hour Diagram

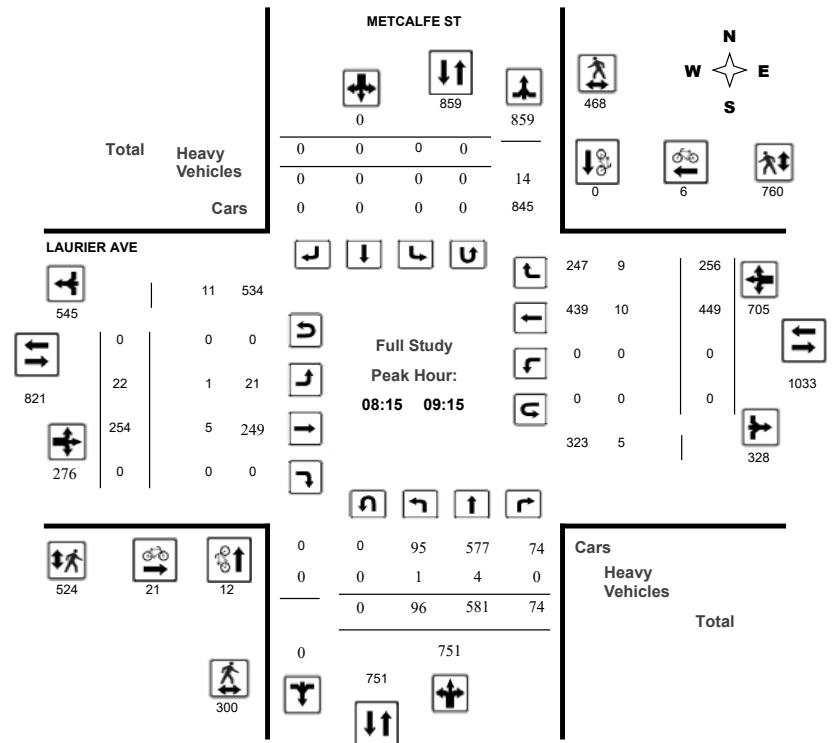



# Transportation Services - Traffic Services

## Turning Movement Count - Peak Hour Diagram

### METCALFE ST @ LAURIER AVE

Survey Date: Tuesday, April 04, 2017  
Start Time: 07:00

WO No: 36840  
Device: Miovision

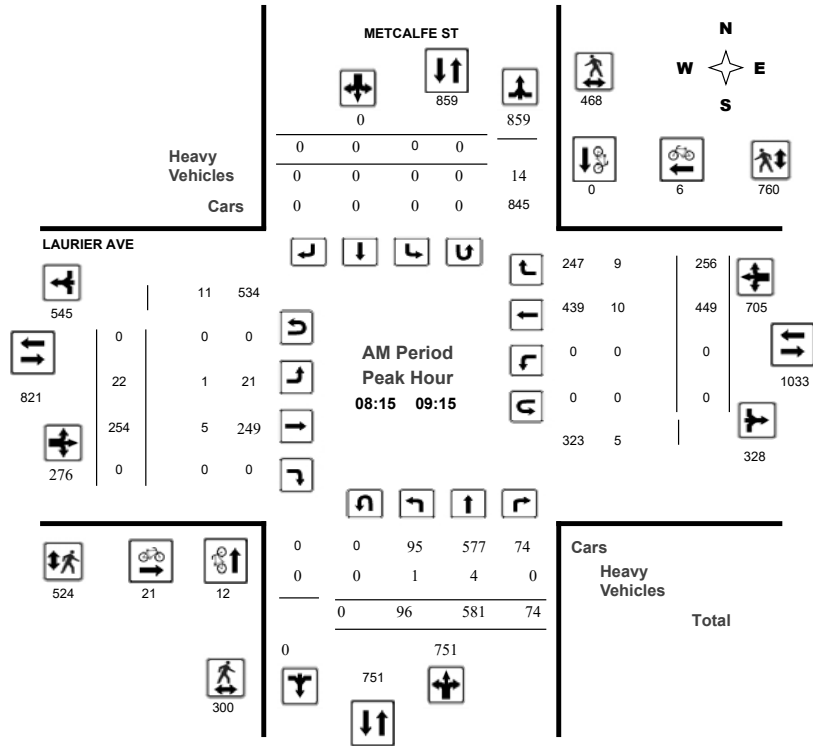

Comments



# Transportation Services - Traffic Services

## Turning Movement Count - Peak Hour Diagram

### METCALFE ST @ LAURIER AVE

Survey Date: Tuesday, April 04, 2017  
Start Time: 07:00

WO No: 36840  
Device: Miovision

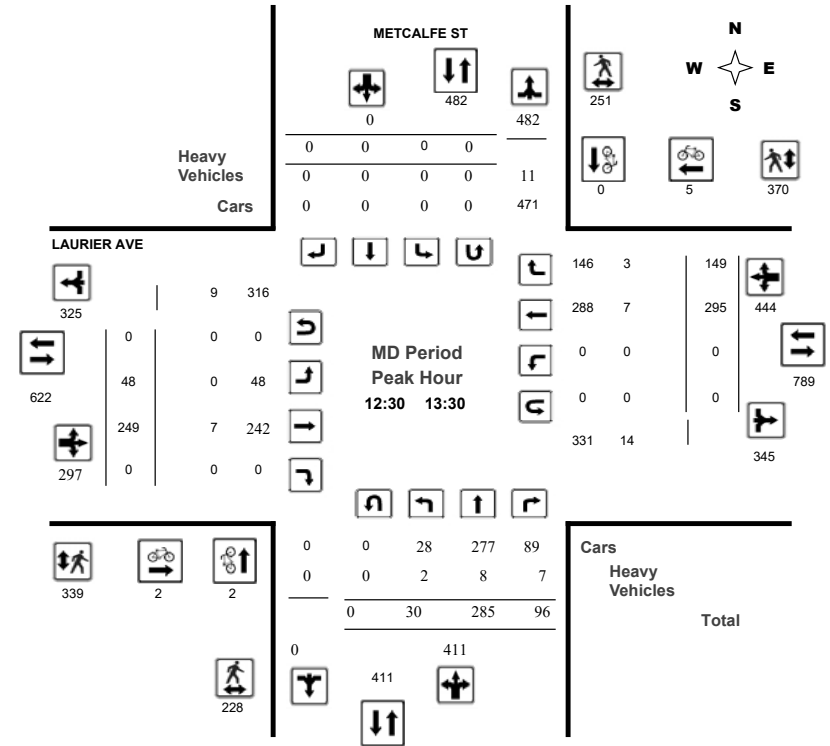

Comments



Transportation Services - Traffic Services

Turning Movement Count - Peak Hour Diagram

METCALFE ST @ LAURIER AVE

Survey Date: Tuesday, April 04, 2017
Start Time: 07:00

WO No: 36840
Device: Miovision

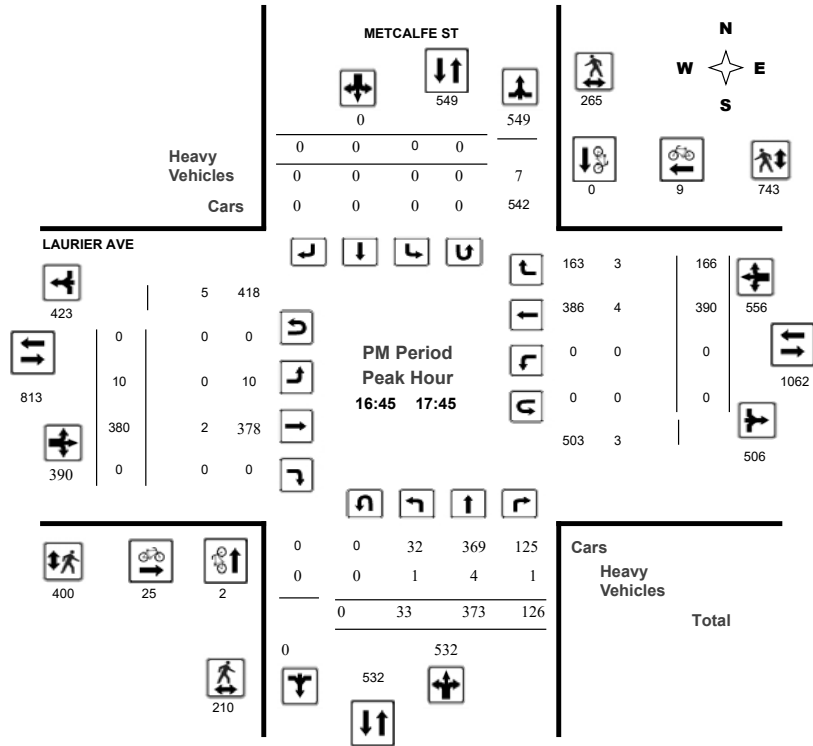

Comments



Transportation Services - Traffic Services

Turning Movement Count - Study Results

METCALFE ST @ LAURIER AVE

Survey Date: Tuesday, April 04, 2017
Start Time: 07:00

WO No: 36840
Device: Miovision

Full Study Summary (8 HR Standard)

Survey Date: Tuesday, April 04, 2017

Total Observed U-Turns: Northbound: 0, Southbound: 0, Eastbound: 0, Westbound: 0

AADT Factor: .90

Table with columns for METCALFE ST (Northbound, Southbound) and LAURIER AVE (Eastbound, Westbound). Rows include time periods (07:00-18:00), Sub Total, U Turns, EQ 12Hr, and AVG 12Hr/24Hr. Includes Grand Total for each period.

Note: These values are calculated by multiplying the totals by the appropriate expansion factor.

Note: These volumes are calculated by multiplying the Equivalent 12 hr. totals by the AADT factor.

Note: These volumes are calculated by multiplying the Average Daily 12 hr. totals by 12 to 24 expansion factor.

Note: U-Turns provided for approach totals. Refer to 'U-Turn' Report for specific breakdown.



Transportation Services - Traffic Services

Turning Movement Count - Study Results

METCALFE ST @ LAURIER AVE

Survey Date: Tuesday, April 04, 2017

WO No: 36840

Start Time: 07:00

Device: Miovision

Full Study Cyclist Volume

Time Period	METCALFE ST			LAURIER AVE			Grand Total
	Northbound	Southbound	Street Total	Eastbound	Westbound	Street Total	
07:00 07:15	0	0	0	3	2	5	5
07:15 07:30	0	0	0	1	7	8	8
07:30 07:45	1	0	1	0	2	2	3
07:45 08:00	3	0	3	1	6	7	10
08:00 08:15	2	0	2	6	0	6	8
08:15 08:30	4	0	4	0	2	2	6
08:30 08:45	3	0	3	7	1	8	11
08:45 09:00	4	0	4	12	1	13	17
09:00 09:15	1	0	1	2	2	4	5
09:15 09:30	3	0	3	0	6	6	9
09:30 09:45	1	0	1	1	3	4	5
09:45 10:00	1	0	1	2	1	3	4
11:30 11:45	0	0	0	1	0	1	1
11:45 12:00	0	0	0	1	2	3	3
12:00 12:15	1	0	1	1	2	3	4
12:15 12:30	0	0	0	1	0	1	1
12:30 12:45	1	0	1	0	1	1	2
12:45 13:00	1	0	1	1	1	2	3
13:00 13:15	0	0	0	0	3	3	3
13:15 13:30	0	0	0	1	0	1	1
15:00 15:15	1	0	1	2	0	2	3
15:15 15:30	1	0	1	1	0	1	2
15:30 15:45	1	0	1	2	0	2	3
15:45 16:00	1	0	1	1	2	3	4
16:00 16:15	0	0	0	4	3	7	7
16:15 16:30	0	0	0	5	2	7	7
16:30 16:45	1	0	1	6	4	10	11
16:45 17:00	0	0	0	6	7	13	13
17:00 17:15	0	0	0	7	0	7	7
17:15 17:30	0	0	0	6	2	8	8
17:30 17:45	2	0	2	6	0	6	8
17:45 18:00	1	0	1	3	0	3	4
Total	34	0	34	90	62	152	186



Transportation Services - Traffic Services

Turning Movement Count - Study Results

METCALFE ST @ LAURIER AVE

Survey Date: Tuesday, April 04, 2017

WO No: 36840

Start Time: 07:00

Device: Miovision

Full Study Pedestrian Volume

Time Period	METCALFE ST			LAURIER AVE			Grand Total
	NB Approach (E or W Crossing)	SB Approach (E or W Crossing)	Total	EB Approach (N or S Crossing)	WB Approach (N or S Crossing)	Total	
07:00 07:15	20	44	64	54	114	168	232
07:15 07:30	30	55	85	76	116	192	277
07:30 07:45	30	59	89	98	163	261	350
07:45 08:00	59	94	153	101	206	307	460
08:00 08:15	64	90	154	104	192	296	450
08:15 08:30	74	108	182	132	181	313	495
08:30 08:45	69	143	212	151	222	373	585
08:45 09:00	97	124	221	157	205	362	583
09:00 09:15	60	93	153	84	152	236	389
09:15 09:30	54	57	111	92	110	202	313
09:30 09:45	44	67	111	63	103	166	277
09:45 10:00	48	60	108	64	83	147	255
11:30 11:45	49	38	87	63	76	139	226
11:45 12:00	49	67	116	89	82	171	287
12:00 12:15	67	78	145	83	97	180	325
12:15 12:30	68	78	146	94	105	199	345
12:30 12:45	65	60	125	84	85	169	294
12:45 13:00	73	90	163	94	111	205	368
13:00 13:15	58	49	107	91	100	191	298
13:15 13:30	32	52	84	70	74	144	228
15:00 15:15	52	59	111	87	123	210	321
15:15 15:30	44	54	98	66	102	168	266
15:30 15:45	49	44	93	72	123	195	288
15:45 16:00	44	46	90	62	118	180	270
16:00 16:15	65	68	133	99	261	360	493
16:15 16:30	64	54	118	94	153	247	365
16:30 16:45	80	76	156	125	209	334	490
16:45 17:00	59	74	133	118	190	308	441
17:00 17:15	61	84	145	98	219	317	462
17:15 17:30	49	55	104	96	195	291	395
17:30 17:45	41	52	93	88	139	227	320
17:45 18:00	36	53	89	92	115	207	296
Total	1754	2225	3979	2941	4524	7465	11444





Transportation Services - Traffic Services

Turning Movement Count - Study Results

METCALFE ST @ LAURIER AVE

Survey Date: Tuesday, April 04, 2017

WO No: 36840

Start Time: 07:00

Device: Miovision

Full Study Heavy Vehicles

METCALFE ST LAURIER AVE

Table with columns for Time Period, Northbound (LT, ST, RT, N TOT), Southbound (LT, ST, RT, S TOT), Eastbound (LT, ST, RT, E TOT), Westbound (LT, ST, RT, W TOT), STR TOT, Grand Total. Rows show 15-minute intervals from 07:00 to 17:45.



Transportation Services - Traffic Services

Turning Movement Count - Study Results

METCALFE ST @ LAURIER AVE

Survey Date: Tuesday, April 04, 2017

WO No: 36840

Start Time: 07:00

Device: Miovision

Full Study 15 Minute U-Turn Total

METCALFE ST LAURIER AVE

Table with columns for Time Period, Northbound U-Turn Total, Southbound U-Turn Total, Eastbound U-Turn Total, Westbound U-Turn Total, Total. Rows show 15-minute intervals from 07:00 to 17:45.

# Appendix C

Synchro Intersection Worksheets – Existing Conditions

Lanes, Volumes, Timings  
1: O'Connor & Laurier

Existing  
AM Peak Hour

Lane Group	EBL	EBT	EBR	WBL	WBT	WBR	NBL	NBT	NBR	SBL	SBT	SBR
Lane Configurations		↔	↔	↔	↔	↔	↔	↔	↔	↔	↔	↔
Traffic Volume (vph)	0	210	122	133	332	0	0	0	0	85	446	67
Future Volume (vph)	0	210	122	133	332	0	0	0	0	85	446	67
Satd. Flow (prot)	0	1425	0	1642	1712	0	0	0	0	0	4173	0
Fit Permitted				0.350							0.993	
Satd. Flow (perm)	0	1425	0	605	1712	0	0	0	0	0	3782	0
Satd. Flow (RTOR)												
Lane Group Flow (vph)	0	369	0	148	369	0	0	0	0	0	664	0
Turn Type		NA		pm+pt	NA					Perm	NA	
Protected Phases		2		9	6						4	
Permitted Phases				6						4		
Detector Phase		2		9	6					4	4	
Switch Phase												
Minimum Initial (s)		10.0		5.0	10.0					10.0	10.0	
Minimum Split (s)		23.9		10.8	21.9					22.5	22.5	
Total Split (s)		29.0		11.0	45.0					25.0	25.0	
Total Split (%)		38.7%		14.7%	60.0%					33.3%	33.3%	
Yellow Time (s)		3.3		3.3	3.3					3.3	3.3	
All-Red Time (s)		2.6		2.5	2.6					2.6	2.6	
Lost Time Adjust (s)		0.0		0.0	0.0					0.0	0.0	
Total Lost Time (s)		5.9		5.8	5.9					5.9	5.9	
Lead/Lag				Lead						Lag	Lag	
Lead-Lag Optimize?				Yes						Yes	Yes	
Recall Mode		C-Max		Max	C-Max					Max	Max	
Act Effct Green (s)		28.1		39.2	39.1					24.1	24.1	
Actuated g/C Ratio		0.37		0.52	0.52					0.32	0.32	
v/c Ratio		0.69		0.38	0.41					0.55	0.55	
Control Delay		28.0		7.6	6.9					23.0	23.0	
Queue Delay		0.0		0.0	0.0					0.0	0.0	
Total Delay		28.0		7.6	6.9					23.0	23.0	
LOS		C		A	A					C	C	
Approach Delay		28.0			7.1					23.0	23.0	
Approach LOS		C			A					C	C	
Queue Length 50th (m)		43.0		5.8	14.8					27.9	27.9	
Queue Length 95th (m)		72.7		m9.9	21.6					38.8	38.8	
Internal Link Dist (m)		71.8			158.7			39.2		62.3	62.3	
Turn Bay Length (m)												
Base Capacity (vph)		533		388	892					1215	1215	
Starvation Cap Reductn		0		0	0					0	0	
Spillback Cap Reductn		0		0	0					0	0	
Storage Cap Reductn		0		0	0					0	0	
Reduced v/c Ratio		0.69		0.38	0.41					0.55	0.55	

Intersection Summary	
Cycle Length: 75	
Actuated Cycle Length: 75	
Offset: 63 (84%), Referenced to phase 2:EBT and 6:WBTL, Start of Green	
Natural Cycle: 70	
Control Type: Actuated-Coordinated	

Lanes, Volumes, Timings  
1: O'Connor & Laurier

Existing  
AM Peak Hour

Lane Group	Ø1	Ø3
Lane Configurations		
Traffic Volume (vph)		
Future Volume (vph)		
Satd. Flow (prot)		
Fit Permitted		
Satd. Flow (perm)		
Satd. Flow (RTOR)		
Lane Group Flow (vph)		
Turn Type		
Protected Phases	1	3
Permitted Phases		
Detector Phase		
Switch Phase		
Minimum Initial (s)	1.0	1.0
Minimum Split (s)	5.0	5.0
Total Split (s)	5.0	5.0
Total Split (%)	7%	7%
Yellow Time (s)	2.0	2.0
All-Red Time (s)	0.0	0.0
Lost Time Adjust (s)		
Total Lost Time (s)		
Lead/Lag	Lag	Lead
Lead-Lag Optimize?	Yes	Yes
Recall Mode	None	None
Act Effct Green (s)		
Actuated g/C Ratio		
v/c Ratio		
Control Delay		
Queue Delay		
Total Delay		
LOS		
Approach Delay		
Approach LOS		
Queue Length 50th (m)		
Queue Length 95th (m)		
Internal Link Dist (m)		
Turn Bay Length (m)		
Base Capacity (vph)		
Starvation Cap Reductn		
Spillback Cap Reductn		
Storage Cap Reductn		
Reduced v/c Ratio		

Intersection Summary	
Cycle Length: 75	
Actuated Cycle Length: 75	
Offset: 63 (84%), Referenced to phase 2:EBT and 6:WBTL, Start of Green	
Natural Cycle: 70	
Control Type: Actuated-Coordinated	

Lanes, Volumes, Timings  
1: O'Connor & Laurier

Existing  
AM Peak Hour

Maximum v/c Ratio: 0.69	Intersection LOS: B
Intersection Signal Delay: 18.9	ICU Level of Service B
Intersection Capacity Utilization 60.9%	
Analysis Period (min) 15	

m Volume for 95th percentile queue is metered by upstream signal.

Splits and Phases: 1: O'Connor & Laurier

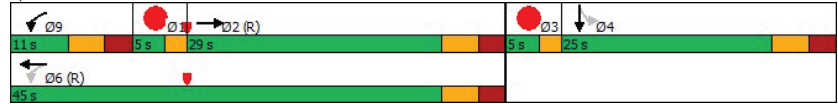

Lanes, Volumes, Timings  
2: Metcalfe & Laurier

Existing  
AM Peak Hour

Lane Group	EBL	EBT	EBR	WBL	WBT	WBR	NBL	NBT	NBR	SBL	SBT	SBR
Lane Configurations		↕			↕			↕				
Traffic Volume (vph)	22	283	0	0	389	256	96	624	74	0	0	0
Future Volume (vph)	22	283	0	0	389	256	96	624	74	0	0	0
Satd. Flow (prot)	0	1734	0	0	2510	0	0	4316	0	0	0	0
Fit Permitted		0.929						0.994				
Satd. Flow (perm)	0	1604	0	0	2510	0	0	4102	0	0	0	0
Satd. Flow (RTOR)												
Lane Group Flow (vph)	0	338	0	0	716	0	0	882	0	0	0	0
Turn Type	Perm	NA			NA		Perm	NA				
Protected Phases		2			6			4				
Permitted Phases	2							4				
Detector Phase	2	2			6			4	4			
Switch Phase												
Minimum Initial (s)	10.0	10.0			10.0			10.0	10.0			
Minimum Split (s)	37.0	37.0			37.0			33.0	33.0			
Total Split (s)	37.0	37.0			37.0			33.0	33.0			
Total Split (%)	49.3%	49.3%			49.3%			44.0%	44.0%			
Yellow Time (s)	3.3	3.3			3.3			3.3	3.3			
All-Red Time (s)	2.4	2.4			2.4			2.2	2.2			
Lost Time Adjust (s)		0.0			0.0			0.0	0.0			
Total Lost Time (s)		5.7			5.7			5.5	5.5			
Lead/Lag	Lag	Lag			Lag							
Lead-Lag Optimize?	Yes	Yes			Yes							
Recall Mode	C-Max	C-Max			C-Max			Max	Max			
Act Effct Green (s)		36.3			36.3				27.5			
Actuated g/C Ratio		0.48			0.48				0.37			
v/c Ratio		0.44			0.59				0.59			
Control Delay		20.1			16.5				15.7			
Queue Delay		0.0			0.0				0.4			
Total Delay		20.1			16.5				16.1			
LOS		C			B				B			
Approach Delay		20.1			16.5				16.1			
Approach LOS		C			B				B			
Queue Length 50th (m)		36.1			36.4				37.6			
Queue Length 95th (m)		m61.4			52.7				49.9			
Internal Link Dist (m)		158.7			172.2				51.7		65.1	
Turn Bay Length (m)												
Base Capacity (vph)		776			1214				1504			
Starvation Cap Reductn		0			0				225			
Spillback Cap Reductn		0			0				0			
Storage Cap Reductn		0			0				0			
Reduced v/c Ratio		0.44			0.59				0.69			

Intersection Summary	
Cycle Length: 75	
Actuated Cycle Length: 75	
Offset: 48 (64%), Referenced to phase 2:EBTL and 6:WBT, Start of Green	
Natural Cycle: 75	
Control Type: Actuated-Coordinated	

Lanes, Volumes, Timings  
2: Metcalfe & Laurier

Existing  
AM Peak Hour

Lane Group	Ø1	Ø5
Lane Configurations		
Traffic Volume (vph)		
Future Volume (vph)		
Satd. Flow (prot)		
Fit Permitted		
Satd. Flow (perm)		
Satd. Flow (RTOR)		
Lane Group Flow (vph)		
Turn Type		
Protected Phases	1	5
Permitted Phases		
Detector Phase		
Switch Phase		
Minimum Initial (s)	1.0	1.0
Minimum Split (s)	5.0	5.0
Total Split (s)	5.0	5.0
Total Split (%)	7%	7%
Yellow Time (s)	2.0	2.0
All-Red Time (s)	0.0	0.0
Lost Time Adjust (s)		
Total Lost Time (s)		
Lead/Lag	Lead	Lead
Lead-Lag Optimize?	Yes	Yes
Recall Mode	None	None
Act Effct Green (s)		
Actuated g/C Ratio		
v/c Ratio		
Control Delay		
Queue Delay		
Total Delay		
LOS		
Approach Delay		
Approach LOS		
Queue Length 50th (m)		
Queue Length 95th (m)		
Internal Link Dist (m)		
Turn Bay Length (m)		
Base Capacity (vph)		
Starvation Cap Reductn		
Spillback Cap Reductn		
Storage Cap Reductn		
Reduced v/c Ratio		
Intersection Summary		

Lanes, Volumes, Timings  
2: Metcalfe & Laurier

Existing  
AM Peak Hour

Maximum v/c Ratio: 0.59	
Intersection Signal Delay: 17.0	Intersection LOS: B
Intersection Capacity Utilization 64.0%	ICU Level of Service B
Analysis Period (min) 15	
m Volume for 95th percentile queue is metered by upstream signal.	

Splits and Phases: 2: Metcalfe & Laurier



Lanes, Volumes, Timings  
3: Elgin & Laurier/City Hall

Existing  
AM Peak Hour

Lane Group	EBL	EBT	EBR	WBL	WBT	WBR	NBL	NBT	NBR	SBL	SBT	SBR
Lane Configurations		↑↑		↑	↑	↑		↑↑	↑	↑↑	↑↑	
Traffic Volume (vph)	0	280	57	209	495	538	0	203	59	361	358	170
Future Volume (vph)	0	280	57	209	495	538	0	203	59	361	358	170
Satd. Flow (prot)	0	3041	0	1658	1745	1483	0	3316	1483	3154	2408	0
Fit Permitted				0.503					0.950			
Satd. Flow (perm)	0	3041	0	739	1745	920	0	3316	680	1900	2408	0
Satd. Flow (RTOR)						238			149			99
Lane Group Flow (vph)	0	374	0	232	550	598	0	226	66	401	587	0
Turn Type		NA		custom	NA	custom		NA	pm+ov	Prot	NA	
Protected Phases		2		9	5	6		3	4	9	3	8
Permitted Phases				6		6			4			
Detector Phase		2		9	5	6		3	4	9	3	8
Switch Phase												
Minimum Initial (s)		5.0		5.0		10.0		10.0	5.0	10.0		10.0
Minimum Split (s)		30.0		12.0		20.7		28.2	12.0	20.7		28.2
Total Split (s)		31.0		15.0		20.8		28.2	15.0	20.8		49.0
Total Split (%)		31.0%		15.0%		20.8%		28.2%	15.0%	20.8%		49.0%
Yellow Time (s)		3.3		3.3		3.3		3.3	3.3	3.3		3.3
All-Red Time (s)		3.7		3.7		4.4		2.9	3.7	4.4		2.9
Lost Time Adjust (s)		0.0		0.0		0.0		0.0	0.0	0.0		0.0
Total Lost Time (s)		7.0		7.0		7.7		6.2	7.0	7.7		6.2
Lead/Lag				Lead		Lead		Lag	Lead		Lead	
Lead-Lag Optimize?				Yes		Yes		Yes	Yes		Yes	
Recall Mode		C-Max		Max		None		Max	Max		None	Max
Act Effct Green (s)		29.0		37.0		49.0		22.0	29.2		13.1	42.8
Actuated g/C Ratio		0.29		0.37		0.49		0.22	0.29		0.13	0.43
v/c Ratio		0.42		0.67		0.64		0.31	0.18		0.97	0.54
Control Delay		30.6		31.4		23.3		34.0	1.1		82.1	19.6
Queue Delay		0.0		0.0		0.0		0.0	0.0		0.0	0.0
Total Delay		30.6		31.4		23.3		34.0	1.1		82.1	19.6
LOS		C		C		C		C	A		F	B
Approach Delay		30.6				39.4		26.6				44.9
Approach LOS		C				D		C				D
Queue Length 50th (m)		30.8		28.5		76.4		19.4	0.0		40.4	35.8
Queue Length 95th (m)		44.1		45.9		112.0		30.0	0.0		#69.4	52.0
Internal Link Dist (m)		172.2				106.8		136.3				52.8
Turn Bay Length (m)									90.0		85.0	
Base Capacity (vph)		881		346		855		729	368		413	1087
Starvation Cap Reductn		0		0		0		0	0		0	0
Spillback Cap Reductn		0		0		0		0	0		0	0
Storage Cap Reductn		0		0		0		0	0		0	0
Reduced v/c Ratio		0.42		0.67		0.64		0.31	0.18		0.97	0.54

Intersection Summary

Cycle Length: 100  
Actuated Cycle Length: 100  
Offset: 64 (64%), Referenced to phase 2:EBT and 6:WBTL, Start of Green  
Natural Cycle: 100  
Control Type: Actuated-Coordinated

Lanes, Volumes, Timings  
3: Elgin & Laurier/City Hall

Existing  
AM Peak Hour

Lane Group	Ø1	Ø5	Ø6	Ø13
Lane Configurations				
Traffic Volume (vph)				
Future Volume (vph)				
Satd. Flow (prot)				
Fit Permitted				
Satd. Flow (perm)				
Satd. Flow (RTOR)				
Lane Group Flow (vph)				
Turn Type				
Protected Phases	1	5	6	13
Permitted Phases				
Detector Phase				
Switch Phase				
Minimum Initial (s)	1.0	1.0	5.0	1.0
Minimum Split (s)	5.0	7.0	25.0	5.0
Total Split (s)	5.0	10.0	36.0	5.0
Total Split (%)	5%	10%	36%	5%
Yellow Time (s)	2.0	2.0	2.0	2.0
All-Red Time (s)	0.0	0.0	0.0	0.0
Lost Time Adjust (s)				
Total Lost Time (s)				
Lead/Lag	Lag	Lag		Lead
Lead-Lag Optimize?	Yes	Yes		Yes
Recall Mode	None	None	C-Max	None
Act Effct Green (s)				
Actuated g/C Ratio				
v/c Ratio				
Control Delay				
Queue Delay				
Total Delay				
LOS				
Approach Delay				
Approach LOS				
Queue Length 50th (m)				
Queue Length 95th (m)				
Internal Link Dist (m)				
Turn Bay Length (m)				
Base Capacity (vph)				
Starvation Cap Reductn				
Spillback Cap Reductn				
Storage Cap Reductn				
Reduced v/c Ratio				

Intersection Summary

Lanes, Volumes, Timings  
3: Elgin & Laurier/City Hall

Existing  
AM Peak Hour

Maximum v/c Ratio: 1.01	Intersection LOS: D
Intersection Signal Delay: 38.9	ICU Level of Service E
Intersection Capacity Utilization 83.8%	
Analysis Period (min) 15	
~ Volume exceeds capacity, queue is theoretically infinite.	
Queue shown is maximum after two cycles.	
# 95th percentile volume exceeds capacity, queue may be longer.	
Queue shown is maximum after two cycles.	

Splits and Phases: 3: Elgin & Laurier/City Hall

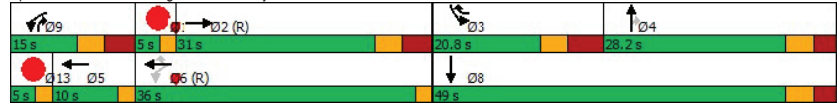

Lanes, Volumes, Timings  
4: Metcalfe & Gloucester

Existing  
AM Peak Hour

Lane Group	EBL	EBT	EBR	WBL	WBT	WBR	NBL	NBT	NBR	SBL	SBT	SBR
Lane Configurations					↕↕			↕↕↕				
Traffic Volume (vph)	0	0	0	0	162	74	223	720	0	0	0	0
Future Volume (vph)	0	0	0	0	162	74	223	720	0	0	0	0
Satd. Flow (prot)	0	0	0	0	2844	0	0	4696	0	0	0	0
Fit Permitted								0.988				
Satd. Flow (perm)	0	0	0	0	2844	0	0	4325	0	0	0	0
Satd. Flow (RTOR)					27			82				
Lane Group Flow (vph)	0	0	0	0	262	0	0	1048	0	0	0	0
Turn Type					NA			Perm	NA			
Protected Phases					4			2				
Permitted Phases								2				
Detector Phase					4			2	2			
Switch Phase												
Minimum Initial (s)					10.0			10.0	10.0			
Minimum Split (s)					23.1			35.0	35.0			
Total Split (s)					25.0			50.0	50.0			
Total Split (%)					33.3%			66.7%	66.7%			
Yellow Time (s)					3.3			3.3	3.3			
All-Red Time (s)					1.8			1.7	1.7			
Lost Time Adjust (s)					0.0			0.0	0.0			
Total Lost Time (s)					5.1			5.0	5.0			
Lead/Lag												
Lead-Lag Optimize?												
Recall Mode					Max			C-Max	C-Max			
Act Effct Green (s)					19.9			45.0	45.0			
Actuated g/C Ratio					0.27			0.60	0.60			
v/c Ratio					0.34			0.40	0.40			
Control Delay					21.3			7.7	7.7			
Queue Delay					0.0			0.0	0.0			
Total Delay					21.3			7.7	7.7			
LOS					C			A	A			
Approach Delay					21.3			7.7	7.7			
Approach LOS					C			A	A			
Queue Length 50th (m)					14.0			23.1	23.1			
Queue Length 95th (m)					23.5			30.8	30.8			
Internal Link Dist (m)						34.9		48.3	35.0			51.7
Turn Bay Length (m)												
Base Capacity (vph)					774			2627	2627			
Starvation Cap Reductn					0			0	0			
Spillback Cap Reductn					0			163	163			
Storage Cap Reductn					0			0	0			
Reduced v/c Ratio					0.34			0.43	0.43			

Intersection Summary

Cycle Length: 75
Actuated Cycle Length: 75
Offset: 73 (97%), Referenced to phase 2:NBTL, Start of Green
Natural Cycle: 60
Control Type: Actuated-Coordinated

Lanes, Volumes, Timings  
4: Metcalfe & Gloucester

Existing  
AM Peak Hour

Maximum v/c Ratio: 0.40	Intersection LOS: B
Intersection Signal Delay: 10.5	ICU Level of Service A
Intersection Capacity Utilization 41.7%	
Analysis Period (min) 15	

Splits and Phases: 4: Metcalfe & Gloucester



Lanes, Volumes, Timings  
5: Elgin & Nepean/City Hall

Existing  
AM Peak Hour

Lane Group	EBL	EBT	EBR	WBL	WBT	WBR	NBL	NBT	NBR	SBL	SBT	SBR
Lane Configurations		↔		↔		↔		↔		↔	↔	↔
Traffic Volume (vph)	31	7	31	1	0	9	0	267	43	17	320	0
Future Volume (vph)	31	7	31	1	0	9	0	267	43	17	320	0
Satd. Flow (prot)	0	1508	0	1658	0	1483	0	3072	0	1658	3252	0
Fit Permitted		0.978		0.708						0.545		
Satd. Flow (perm)	0	1429	0	1182	0	1294	0	3072	0	836	3252	0
Satd. Flow (RTOR)		34				53		34				
Lane Group Flow (vph)	0	76	0	1	0	10	0	345	0	19	356	0
Turn Type	Perm	NA	Perm	Perm	NA	Perm	NA	Perm	NA	Perm	NA	
Protected Phases		4						2			6	
Permitted Phases	4			8		8				6		
Detector Phase	4	4		8		8		2		6	6	
Switch Phase												
Minimum Initial (s)	10.0	10.0		10.0		10.0		10.0		10.0	10.0	
Minimum Split (s)	25.1	25.1		25.1		25.1		31.4		31.4	31.4	
Total Split (s)	27.0	27.0		27.0		27.0		58.0		58.0	58.0	
Total Split (%)	30.0%	30.0%		30.0%		30.0%		64.4%		64.4%	64.4%	
Yellow Time (s)	3.3	3.3		3.3		3.3		3.3		3.3	3.3	
All-Red Time (s)	2.8	2.8		2.8		2.8		2.1		2.1	2.1	
Lost Time Adjust (s)		0.0		0.0		0.0		0.0		0.0	0.0	
Total Lost Time (s)		6.1		6.1		6.1		5.4		5.4	5.4	
Lead/Lag	Lag	Lag		Lag		Lag						
Lead-Lag Optimize?	Yes	Yes		Yes		Yes						
Recall Mode	Max	Max		Max		Max		C-Max		C-Max	C-Max	
Act Effct Green (s)		25.9		25.9		25.9		52.6		52.6	52.6	
Actuated g/C Ratio		0.29		0.29		0.29		0.58		0.58	0.58	
v/c Ratio		0.17		0.00		0.02		0.19		0.04	0.19	
Control Delay		16.1		23.0		0.1		8.1		8.3	9.0	
Queue Delay		0.0		0.0		0.0		0.0		0.0	0.0	
Total Delay		16.1		23.0		0.1		8.1		8.3	9.0	
LOS		B		C		A		A		A	A	
Approach Delay		16.1				2.2		8.1			9.0	
Approach LOS		B				A		A			A	
Queue Length 50th (m)		5.3		0.1		0.0		12.0		1.3	13.9	
Queue Length 95th (m)		15.5		1.3		0.0		18.4		4.1	20.4	
Internal Link Dist (m)		54.5				21.0		120.5			136.3	
Turn Bay Length (m)										20.0		
Base Capacity (vph)		435		340		410		1809		488	1900	
Starvation Cap Reductn		0		0		0		0		0	0	
Spillback Cap Reductn		0		0		0		0		0	0	
Storage Cap Reductn		0		0		0		0		0	0	
Reduced v/c Ratio		0.17		0.00		0.02		0.19		0.04	0.19	

Intersection Summary

Cycle Length: 90
Actuated Cycle Length: 90
Offset: 0 (0%), Referenced to phase 2:NBT and 6:SBTL, Start of Green
Natural Cycle: 65
Control Type: Actuated-Coordinated



Lanes, Volumes, Timings  
5: Elgin & Nepean/City Hall

Existing  
AM Peak Hour

Lane Group	Ø3	Ø7
Lane Configurations		
Traffic Volume (vph)		
Future Volume (vph)		
Satd. Flow (prot)		
Fit Permitted		
Satd. Flow (perm)		
Satd. Flow (RTOR)		
Lane Group Flow (vph)		
Turn Type		
Protected Phases	3	7
Permitted Phases		
Detector Phase		
Switch Phase		
Minimum Initial (s)	1.0	1.0
Minimum Split (s)	5.0	5.0
Total Split (s)	5.0	5.0
Total Split (%)	6%	6%
Yellow Time (s)	2.0	2.0
All-Red Time (s)	0.0	0.0
Lost Time Adjust (s)		
Total Lost Time (s)		
Lead/Lag	Lead	Lead
Lead-Lag Optimize?	Yes	Yes
Recall Mode	None	None
Act Effct Green (s)		
Actuated g/C Ratio		
v/c Ratio		
Control Delay		
Queue Delay		
Total Delay		
LOS		
Approach Delay		
Approach LOS		
Queue Length 50th (m)		
Queue Length 95th (m)		
Internal Link Dist (m)		
Turn Bay Length (m)		
Base Capacity (vph)		
Starvation Cap Reductn		
Spillback Cap Reductn		
Storage Cap Reductn		
Reduced v/c Ratio		
Intersection Summary		

Lanes, Volumes, Timings  
5: Elgin & Nepean/City Hall

Existing  
AM Peak Hour

Maximum v/c Ratio: 0.19	Intersection LOS: A
Intersection Signal Delay: 9.2	ICU Level of Service C
Intersection Capacity Utilization 66.3%	
Analysis Period (min) 15	

Splits and Phases: 5: Elgin & Nepean/City Hall

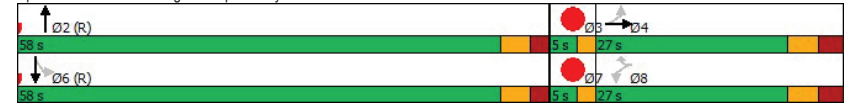

Lanes, Volumes, Timings  
1: O'Connor & Laurier

Existing  
PM Peak Hour

Lane Group	EBL	EBT	EBR	WBL	WBT	WBR	NBL	NBT	NBR	SBL	SBT	SBR
Lane Configurations		↔	↔	↔	↔	↔				↔	↔	↔
Traffic Volume (vph)	0	200	95	179	271	0	0	0	0	51	540	44
Future Volume (vph)	0	200	95	179	271	0	0	0	0	51	540	44
Satd. Flow (prot)	0	1467	0	1642	1745	0	0	0	0	0	4479	0
Fit Permitted				0.391							0.996	
Satd. Flow (perm)	0	1467	0	676	1745	0	0	0	0	0	4246	0
Satd. Flow (RTOR)												
Lane Group Flow (vph)	0	328	0	199	301	0	0	0	0	0	706	0
Turn Type		NA		pm+pt	NA					Perm	NA	
Protected Phases		2		9	6						4	
Permitted Phases				6						4		
Detector Phase		2		9	6					4	4	
Switch Phase												
Minimum Initial (s)		10.0		5.0	10.0					10.0	10.0	
Minimum Split (s)		23.9		10.8	21.9					22.5	22.5	
Total Split (s)		29.0		11.0	45.0					25.0	25.0	
Total Split (%)		38.7%		14.7%	60.0%					33.3%	33.3%	
Yellow Time (s)		3.3		3.3	3.3					3.3	3.3	
All-Red Time (s)		2.6		2.5	2.6					2.6	2.6	
Lost Time Adjust (s)		0.0		0.0	0.0					0.0	0.0	
Total Lost Time (s)		5.9		5.8	5.9					5.9	5.9	
Lead/Lag				Lead						Lag	Lag	
Lead-Lag Optimize?				Yes						Yes	Yes	
Recall Mode		C-Max		Max	C-Max					Max	Max	
Act Effct Green (s)		28.1		39.2	39.1					24.1	24.1	
Actuated g/C Ratio		0.37		0.52	0.52					0.32	0.32	
v/c Ratio		0.60		0.47	0.33					0.52	0.52	
Control Delay		24.4		21.7	16.2					22.4	22.4	
Queue Delay		0.0		0.0	0.0					0.0	0.0	
Total Delay		24.4		21.7	16.2					22.4	22.4	
LOS		C		C	B					C	C	
Approach Delay		24.4			18.4					22.4	22.4	
Approach LOS		C			B					C	C	
Queue Length 50th (m)		36.5		18.4	25.4					29.4	29.4	
Queue Length 95th (m)		61.8		37.0	46.4					40.1	40.1	
Internal Link Dist (m)		71.8			158.7			39.2		62.3	62.3	
Turn Bay Length (m)												
Base Capacity (vph)		549		420	909					1364	1364	
Starvation Cap Reductn		0		0	0					0	0	
Spillback Cap Reductn		0		0	0					0	0	
Storage Cap Reductn		0		0	0					0	0	
Reduced v/c Ratio		0.60		0.47	0.33					0.52	0.52	

Intersection Summary	
Cycle Length: 75	
Actuated Cycle Length: 75	
Offset: 22 (29%), Referenced to phase 2:EBT and 6:WBTL, Start of Green	
Natural Cycle: 70	
Control Type: Actuated-Coordinated	

Lanes, Volumes, Timings  
1: O'Connor & Laurier

Existing  
PM Peak Hour

Lane Group	Ø1	Ø3
Lane Configurations		
Traffic Volume (vph)		
Future Volume (vph)		
Satd. Flow (prot)		
Fit Permitted		
Satd. Flow (perm)		
Satd. Flow (RTOR)		
Lane Group Flow (vph)		
Turn Type		
Protected Phases	1	3
Permitted Phases		
Detector Phase		
Switch Phase		
Minimum Initial (s)	1.0	1.0
Minimum Split (s)	5.0	5.0
Total Split (s)	5.0	5.0
Total Split (%)	7%	7%
Yellow Time (s)	2.0	2.0
All-Red Time (s)	0.0	0.0
Lost Time Adjust (s)		
Total Lost Time (s)		
Lead/Lag	Lag	Lead
Lead-Lag Optimize?	Yes	Yes
Recall Mode	None	None
Act Effct Green (s)		
Actuated g/C Ratio		
v/c Ratio		
Control Delay		
Queue Delay		
Total Delay		
LOS		
Approach Delay		
Approach LOS		
Queue Length 50th (m)		
Queue Length 95th (m)		
Internal Link Dist (m)		
Turn Bay Length (m)		
Base Capacity (vph)		
Starvation Cap Reductn		
Spillback Cap Reductn		
Storage Cap Reductn		
Reduced v/c Ratio		

Intersection Summary	
Cycle Length: 75	
Actuated Cycle Length: 75	
Offset: 22 (29%), Referenced to phase 2:EBT and 6:WBTL, Start of Green	
Natural Cycle: 70	
Control Type: Actuated-Coordinated	

Lanes, Volumes, Timings  
1: O'Connor & Laurier

Existing  
PM Peak Hour

Maximum v/c Ratio: 0.60	Intersection LOS: C
Intersection Signal Delay: 21.5	ICU Level of Service B
Intersection Capacity Utilization 61.1%	
Analysis Period (min) 15	

Splits and Phases: 1: O'Connor & Laurier



Lanes, Volumes, Timings  
2: Metcalfe & Laurier

Existing  
PM Peak Hour

Lane Group	EBL	EBT	EBR	WBL	WBT	WBR	NBL	NBT	NBR	SBL	SBT	SBR
Lane Configurations		↕			↕		↕	↕				
Traffic Volume (vph)	10	241	0	0	390	166	33	373	126	0	0	0
Future Volume (vph)	10	241	0	0	390	166	33	373	126	0	0	0
Satd. Flow (prot)	0	1742	0	0	2809	0	0	3706	0	0	0	0
Fit Permitted		0.973						0.997				
Satd. Flow (perm)	0	1689	0	0	2809	0	0	3621	0	0	0	0
Satd. Flow (RTOR)												
Lane Group Flow (vph)	0	279	0	0	617	0	0	591	0	0	0	0
Turn Type	Perm	NA			NA		Perm	NA				
Protected Phases		2			6			4				
Permitted Phases	2						4					
Detector Phase	2	2			6		4	4				
Switch Phase												
Minimum Initial (s)	10.0	10.0			10.0		10.0	10.0				
Minimum Split (s)	37.0	37.0			37.0		19.5	19.5				
Total Split (s)	40.0	40.0			40.0		30.0	30.0				
Total Split (%)	53.3%	53.3%			53.3%		40.0%	40.0%				
Yellow Time (s)	3.3	3.3			3.3		3.3	3.3				
All-Red Time (s)	2.4	2.4			2.4		2.2	2.2				
Lost Time Adjust (s)		0.0			0.0			0.0				
Total Lost Time (s)		5.7			5.7			5.5				
Lead/Lag	Lag	Lag			Lag							
Lead-Lag Optimize?	Yes	Yes			Yes							
Recall Mode	C-Max	C-Max			C-Max		Max	Max				
Act Effct Green (s)		39.3			39.3			24.5				
Actuated g/C Ratio		0.52			0.52			0.33				
v/c Ratio		0.32			0.42			0.50				
Control Delay		6.7			12.0			17.9				
Queue Delay		0.0			0.0			0.3				
Total Delay		6.7			12.0			18.2				
LOS		A			B			B				
Approach Delay		6.7			12.0			18.2				
Approach LOS		A			B			B				
Queue Length 50th (m)		8.9			26.1			16.4				
Queue Length 95th (m)		13.6			37.5			21.2				
Internal Link Dist (m)		158.7			172.2			51.7			65.1	
Turn Bay Length (m)												
Base Capacity (vph)		885			1471			1182				
Starvation Cap Reductn		0			0			174				
Spillback Cap Reductn		0			0			0				
Storage Cap Reductn		0			0			0				
Reduced v/c Ratio		0.32			0.42			0.59				

Intersection Summary

Cycle Length: 75
Actuated Cycle Length: 75
Offset: 30 (40%), Referenced to phase 2:EBTL and 6:WBT, Start of Green
Natural Cycle: 65
Control Type: Actuated-Coordinated

Lanes, Volumes, Timings  
2: Metcalfe & Laurier

Existing  
PM Peak Hour

Lane Group	Ø1	Ø5
Lane Configurations		
Traffic Volume (vph)		
Future Volume (vph)		
Satd. Flow (prot)		
Fit Permitted		
Satd. Flow (perm)		
Satd. Flow (RTOR)		
Lane Group Flow (vph)		
Turn Type		
Protected Phases	1	5
Permitted Phases		
Detector Phase		
Switch Phase		
Minimum Initial (s)	1.0	1.0
Minimum Split (s)	5.0	5.0
Total Split (s)	5.0	5.0
Total Split (%)	7%	7%
Yellow Time (s)	2.0	2.0
All-Red Time (s)	0.0	0.0
Lost Time Adjust (s)		
Total Lost Time (s)		
Lead/Lag	Lead	Lead
Lead-Lag Optimize?	Yes	Yes
Recall Mode	None	None
Act Effct Green (s)		
Actuated g/C Ratio		
v/c Ratio		
Control Delay		
Queue Delay		
Total Delay		
LOS		
Approach Delay		
Approach LOS		
Queue Length 50th (m)		
Queue Length 95th (m)		
Internal Link Dist (m)		
Turn Bay Length (m)		
Base Capacity (vph)		
Starvation Cap Reductn		
Spillback Cap Reductn		
Storage Cap Reductn		
Reduced v/c Ratio		
Intersection Summary		

Lanes, Volumes, Timings  
2: Metcalfe & Laurier

Existing  
PM Peak Hour

Maximum v/c Ratio: 0.50	Intersection LOS: B
Intersection Signal Delay: 13.5	ICU Level of Service A
Intersection Capacity Utilization 47.4%	
Analysis Period (min) 15	

Splits and Phases: 2: Metcalfe & Laurier



Lanes, Volumes, Timings  
3: Elgin & Laurier

Existing  
PM Peak Hour

Lane Group	EBL	EBT	EBR	WBL	WBT	WBR	NBL	NBT	NBR	SBL	SBT	SBR
Lane Configurations		↑↑		↑	↑	↑		↑↑	↑	↑↑	↑↑	
Traffic Volume (vph)	0	358	29	117	427	413	0	266	161	382	345	108
Future Volume (vph)	0	358	29	117	427	413	0	266	161	382	345	108
Satd. Flow (prot)	0	3155	0	1642	1745	1483	0	3316	1483	3154	2624	0
Fit Permitted				0.468						0.950		
Satd. Flow (perm)	0	3155	0	627	1745	976	0	3316	680	2228	2624	0
Satd. Flow (RTOR)									149		53	
Lane Group Flow (vph)	0	430	0	130	474	459	0	296	179	424	503	0
Turn Type		NA		custom	NA	custom		NA	pm+ov	Prot	NA	
Protected Phases		2		9	5	6		3	4	9	3	8
Permitted Phases				6		6			4			
Detector Phase		2		9	5	6		3	4	9	3	8
Switch Phase												
Minimum Initial (s)		5.0		5.0		10.0		10.0	5.0	10.0	10.0	
Minimum Split (s)		30.0		12.0		20.7		28.2	12.0	20.7	28.2	
Total Split (s)		31.0		14.0		21.8		28.2	14.0	21.8	50.0	
Total Split (%)		31.0%		14.0%		21.8%		28.2%	14.0%	21.8%	50.0%	
Yellow Time (s)		3.3		3.3		3.3		3.3	3.3	3.3	3.3	
All-Red Time (s)		3.7		3.7		4.4		2.9	3.7	4.4	2.9	
Lost Time Adjust (s)		0.0		0.0		0.0		0.0	0.0	0.0	0.0	
Total Lost Time (s)		7.0		7.0		7.7		6.2	7.0	7.7	6.2	
Lead/Lag				Lead		Lead		Lag	Lead		Lead	
Lead-Lag Optimize?				Yes		Yes		Yes	Yes		Yes	
Recall Mode		C-Max		None		None		Max	None	None	Max	
Act Effct Green (s)		29.0		35.0		48.0		22.0	28.2	14.1	43.8	
Actuated g/C Ratio		0.29		0.35		0.48		0.22	0.28	0.14	0.44	
v/c Ratio		0.47		0.45		0.57		0.41	0.51	0.95	0.43	
Control Delay		31.2		23.9		21.9		25.2	8.5	76.6	18.5	
Queue Delay		0.0		0.0		0.0		0.0	0.0	0.0	0.0	
Total Delay		31.2		23.9		21.9		25.2	8.5	76.6	18.5	
LOS		C		C		C		C	A	E	B	
Approach Delay		31.2				21.8		18.9			45.1	
Approach LOS		C				C		B			D	
Queue Length 50th (m)		36.0		15.2		63.2		15.8	1.4	42.6	30.6	
Queue Length 95th (m)		50.5		27.2		93.4		22.9	8.7	#71.4	43.9	
Internal Link Dist (m)		172.2				106.8		136.3			52.8	
Turn Bay Length (m)									90.0	85.0		
Base Capacity (vph)		915		290		837		729	354	444	1179	
Starvation Cap Reductn		0		0		0		0	0	0	0	
Spillback Cap Reductn		0		0		0		0	0	0	0	
Storage Cap Reductn		0		0		0		0	0	0	0	
Reduced v/c Ratio		0.47		0.45		0.57		0.41	0.51	0.95	0.43	

Intersection Summary	
Cycle Length:	100
Actuated Cycle Length:	100
Offset:	52 (52%), Referenced to phase 2:EBT and 6:WBTL, Start of Green
Natural Cycle:	100
Control Type:	Actuated-Coordinated

Lanes, Volumes, Timings  
3: Elgin & Laurier

Existing  
PM Peak Hour

Lane Group	Ø1	Ø5	Ø6	Ø13
Lane Configurations				
Traffic Volume (vph)				
Future Volume (vph)				
Satd. Flow (prot)				
Fit Permitted				
Satd. Flow (perm)				
Satd. Flow (RTOR)				
Lane Group Flow (vph)				
Turn Type				
Protected Phases	1	5	6	13
Permitted Phases				
Detector Phase				
Switch Phase				
Minimum Initial (s)	1.0	1.0	5.0	1.0
Minimum Split (s)	5.0	7.0	25.0	5.0
Total Split (s)	5.0	10.0	35.0	5.0
Total Split (%)	5%	10%	35%	5%
Yellow Time (s)	2.0	2.0	2.0	2.0
All-Red Time (s)	0.0	0.0	0.0	0.0
Lost Time Adjust (s)				
Total Lost Time (s)				
Lead/Lag	Lag	Lag	Lead	Lead
Lead-Lag Optimize?	Yes	Yes	Yes	Yes
Recall Mode	None	None	C-Max	None
Act Effct Green (s)				
Actuated g/C Ratio				
v/c Ratio				
Control Delay				
Queue Delay				
Total Delay				
LOS				
Approach Delay				
Approach LOS				
Queue Length 50th (m)				
Queue Length 95th (m)				
Internal Link Dist (m)				
Turn Bay Length (m)				
Base Capacity (vph)				
Starvation Cap Reductn				
Spillback Cap Reductn				
Storage Cap Reductn				
Reduced v/c Ratio				

Intersection Summary	
Cycle Length:	100
Actuated Cycle Length:	100
Offset:	52 (52%), Referenced to phase 2:EBT and 6:WBTL, Start of Green
Natural Cycle:	100
Control Type:	Actuated-Coordinated

Lanes, Volumes, Timings  
3: Elgin & Laurier

Existing  
PM Peak Hour

Maximum v/c Ratio: 0.95	Intersection LOS: C
Intersection Signal Delay: 30.2	ICU Level of Service D
Intersection Capacity Utilization 79.1%	
Analysis Period (min) 15	
# 95th percentile volume exceeds capacity, queue may be longer.	
Queue shown is maximum after two cycles.	

Splits and Phases: 3: Elgin & Laurier

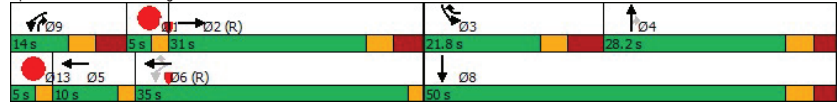

Lanes, Volumes, Timings  
4: Metcalfe & Gloucester

Existing  
PM Peak Hour

Lane Group	EBL	EBT	EBR	WBL	WBT	WBR	NBL	NBT	NBR	SBL	SBT	SBR
Lane Configurations					↑↑			↑↑↑				
Traffic Volume (vph)	0	0	0	0	207	127	96	397	0	0	0	0
Future Volume (vph)	0	0	0	0	207	127	96	397	0	0	0	0
Satd. Flow (prot)	0	0	0	0	2922	0	0	4716	0	0	0	0
Fit Permitted								0.990				
Satd. Flow (perm)	0	0	0	0	2922	0	0	4427	0	0	0	0
Satd. Flow (RTOR)					19			93				
Lane Group Flow (vph)	0	0	0	0	371	0	0	548	0	0	0	0
Turn Type					NA		Perm	NA				
Protected Phases					4			2				
Permitted Phases								2				
Detector Phase					4			2	2			
Switch Phase												
Minimum Initial (s)					10.0			10.0	10.0			
Minimum Split (s)					23.1			35.0	35.0			
Total Split (s)					30.0			45.0	45.0			
Total Split (%)					40.0%			60.0%	60.0%			
Yellow Time (s)					3.3			3.3	3.3			
All-Red Time (s)					1.8			1.7	1.7			
Lost Time Adjust (s)					0.0			0.0	0.0			
Total Lost Time (s)					5.1			5.0	5.0			
Lead/Lag												
Lead-Lag Optimize?												
Recall Mode					Max			C-Max	C-Max			
Act Effct Green (s)					24.9			40.0	40.0			
Actuated g/C Ratio					0.33			0.53	0.53			
v/c Ratio					0.38			0.23	0.23			
Control Delay					19.5			7.9	7.9			
Queue Delay					0.0			0.0	0.0			
Total Delay					19.5			7.9	7.9			
LOS					B			A	A			
Approach Delay					19.5			7.9	7.9			
Approach LOS					B			A	A			
Queue Length 50th (m)					19.6			11.3	11.3			
Queue Length 95th (m)					30.5			16.8	16.8			
Internal Link Dist (m)						34.9		48.3	35.0			51.7
Turn Bay Length (m)												
Base Capacity (vph)					982			2404	2404			
Starvation Cap Reductn					0			0	0			
Spillback Cap Reductn					0			0	0			
Storage Cap Reductn					0			0	0			
Reduced v/c Ratio					0.38			0.23	0.23			

Intersection Summary

Cycle Length: 75
Actuated Cycle Length: 75
Offset: 67 (89%), Referenced to phase 2:NBTL, Start of Green
Natural Cycle: 60
Control Type: Actuated-Coordinated

Lanes, Volumes, Timings  
4: Metcalfe & Gloucester

Existing  
PM Peak Hour

Maximum v/c Ratio: 0.38	Intersection LOS: B
Intersection Signal Delay: 12.6	ICU Level of Service A
Intersection Capacity Utilization 41.9%	
Analysis Period (min) 15	

Splits and Phases: 4: Metcalfe & Gloucester



Lanes, Volumes, Timings  
5: Elgin & Nepean/City Hall

Existing  
PM Peak Hour

Lane Group	EBL	EBT	EBR	WBL	WBT	WBR	NBL	NBT	NBR	SBL	SBT	SBR
Lane Configurations		↔		↔		↔		↔		↔	↔	↔
Traffic Volume (vph)	113	1	107	31	0	23	1	312	5	7	441	0
Future Volume (vph)	113	1	107	31	0	23	1	312	5	7	441	0
Satd. Flow (prot)	0	1491	0	1658	0	1483	0	3256	0	1658	3316	0
Fit Permitted		0.975		0.605				0.954		0.528		
Satd. Flow (perm)	0	1397	0	983	0	1286	0	3105	0	757	3316	0
Satd. Flow (RTOR)		55				48		2				
Lane Group Flow (vph)	0	246	0	34	0	26	0	354	0	8	490	0
Turn Type	Perm	NA	Perm		Perm	Perm	NA		Perm	NA		
Protected Phases		4					2				6	
Permitted Phases	4			8		8	2			6		
Detector Phase	4	4		8		8	2	2		6	6	
Switch Phase												
Minimum Initial (s)	10.0	10.0		10.0		10.0	10.0	10.0		10.0	10.0	
Minimum Split (s)	25.1	25.1		25.1		25.1	31.4	31.4		31.4	31.4	
Total Split (s)	45.0	45.0		45.0		45.0	50.0	50.0		50.0	50.0	
Total Split (%)	45.0%	45.0%		45.0%		45.0%	50.0%	50.0%		50.0%	50.0%	
Yellow Time (s)	3.3	3.3		3.3		3.3	3.3	3.3		3.3	3.3	
All-Red Time (s)	2.8	2.8		2.8		2.8	2.1	2.1		2.1	2.1	
Lost Time Adjust (s)		0.0		0.0		0.0		0.0		0.0	0.0	
Total Lost Time (s)		6.1		6.1		6.1		5.4		5.4	5.4	
Lead/Lag	Lag	Lag		Lag		Lag						
Lead-Lag Optimize?	Yes	Yes		Yes		Yes						
Recall Mode	Max	Max		Max		Max	C-Max	C-Max		C-Max	C-Max	
Act Effct Green (s)		43.9		43.9		43.9		44.6		44.6	44.6	
Actuated g/C Ratio		0.44		0.44		0.44		0.45		0.45	0.45	
v/c Ratio		0.38		0.08		0.04		0.26		0.02	0.33	
Control Delay		16.5		17.1		2.0		17.8		14.1	18.3	
Queue Delay		0.0		0.0		0.0		0.0		0.0	0.0	
Total Delay		16.5		17.1		2.0		17.8		14.1	18.3	
LOS		B		B		A		B		B	B	
Approach Delay		16.5				10.6		17.8			18.2	
Approach LOS		B				B		B			B	
Queue Length 50th (m)		23.7		3.7		0.0		21.7		0.6	37.5	
Queue Length 95th (m)		42.7		9.6		2.2		31.4		m1.3	46.2	
Internal Link Dist (m)		54.5				21.0		120.5			136.3	
Turn Bay Length (m)										20.0		
Base Capacity (vph)		644		431		591		1385		337	1478	
Starvation Cap Reductn		0		0		0		0		0	0	
Spillback Cap Reductn		0		0		0		0		0	0	
Storage Cap Reductn		0		0		0		0		0	0	
Reduced v/c Ratio		0.38		0.08		0.04		0.26		0.02	0.33	

Intersection Summary

Cycle Length: 100
Actuated Cycle Length: 100
Offset: 0 (0%), Referenced to phase 2:NBTL and 6:SBTL, Start of Green
Natural Cycle: 65
Control Type: Actuated-Coordinated

Lanes, Volumes, Timings  
5: Elgin & Nepean/City Hall

Existing  
PM Peak Hour

Lane Group	Ø3	Ø7
Lane Configurations		
Traffic Volume (vph)		
Future Volume (vph)		
Satd. Flow (prot)		
Fit Permitted		
Satd. Flow (perm)		
Satd. Flow (RTOR)		
Lane Group Flow (vph)		
Turn Type		
Protected Phases	3	7
Permitted Phases		
Detector Phase		
Switch Phase		
Minimum Initial (s)	1.0	1.0
Minimum Split (s)	5.0	5.0
Total Split (s)	5.0	5.0
Total Split (%)	5%	5%
Yellow Time (s)	2.0	2.0
All-Red Time (s)	0.0	0.0
Lost Time Adjust (s)		
Total Lost Time (s)		
Lead/Lag	Lead	Lead
Lead-Lag Optimize?	Yes	Yes
Recall Mode	None	None
Act Effct Green (s)		
Actuated g/C Ratio		
v/c Ratio		
Control Delay		
Queue Delay		
Total Delay		
LOS		
Approach Delay		
Approach LOS		
Queue Length 50th (m)		
Queue Length 95th (m)		
Internal Link Dist (m)		
Turn Bay Length (m)		
Base Capacity (vph)		
Starvation Cap Reductn		
Spillback Cap Reductn		
Storage Cap Reductn		
Reduced v/c Ratio		
Intersection Summary		

Lanes, Volumes, Timings  
5: Elgin & Nepean/City Hall

Existing  
PM Peak Hour

Maximum v/c Ratio: 0.38	Intersection LOS: B
Intersection Signal Delay: 17.3	ICU Level of Service C
Intersection Capacity Utilization 66.6%	
Analysis Period (min) 15	
m Volume for 95th percentile queue is metered by upstream signal.	

Splits and Phases: 5: Elgin & Nepean/City Hall

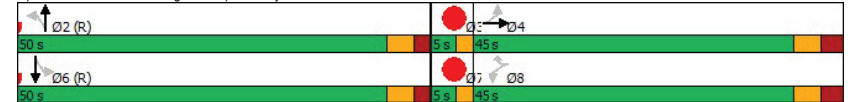



# Appendix D

Collision Data



6/16/2019	2019	10:45	METCALFE ST @ LAURIER AVE (0002231)	01 - Clear	01 - Daylight	01 - Traffic signal	01 - Functioning	03 - P.D. only	03 - Rear end	01 - Dry	3	0	0	0
7/24/2019	2019	9:34	METCALFE ST @ LAURIER AVE (0002231)	01 - Clear	01 - Daylight	01 - Traffic signal	01 - Functioning	03 - P.D. only	04 - Sideswipe	01 - Dry	2	0	0	0
7/31/2019	2019	10:20	METCALFE ST @ LAURIER AVE (0002231)	01 - Clear	01 - Daylight	01 - Traffic signal	01 - Functioning	03 - P.D. only	03 - Rear end	01 - Dry	2	0	0	0
8/12/2019	2019	12:27	METCALFE ST @ LAURIER AVE (0002231)	01 - Clear	01 - Daylight	01 - Traffic signal	01 - Functioning	03 - P.D. only	04 - Sideswipe	01 - Dry	2	0	0	0
1/25/2020	2020	7:53	METCALFE ST @ LAURIER AVE (0002231)	01 - Clear	03 - Dawn	01 - Traffic signal	01 - Functioning	03 - P.D. only	99 - Other	01 - Dry	2	0	0	0
7/3/2020	2020	9:03	METCALFE ST @ LAURIER AVE (0002231)	01 - Clear	01 - Daylight	01 - Traffic signal	01 - Functioning	03 - P.D. only	03 - Rear end	01 - Dry	2	0	0	0
9/28/2020	2020	14:27	METCALFE ST @ LAURIER AVE (0002231)	01 - Clear	01 - Daylight	01 - Traffic signal	01 - Functioning	02 - Non-fatal injury	02 - Angle	01 - Dry	2	0	0	0
1/19/2020	2020	4:59	METCALFE ST @ LAURIER AVE (0002231)	03 - Snow	07 - Dark	01 - Traffic signal	01 - Functioning	03 - P.D. only	03 - Rear end	05 - Packed snow	2	0	0	0

# Appendix E

City TRANS Plots

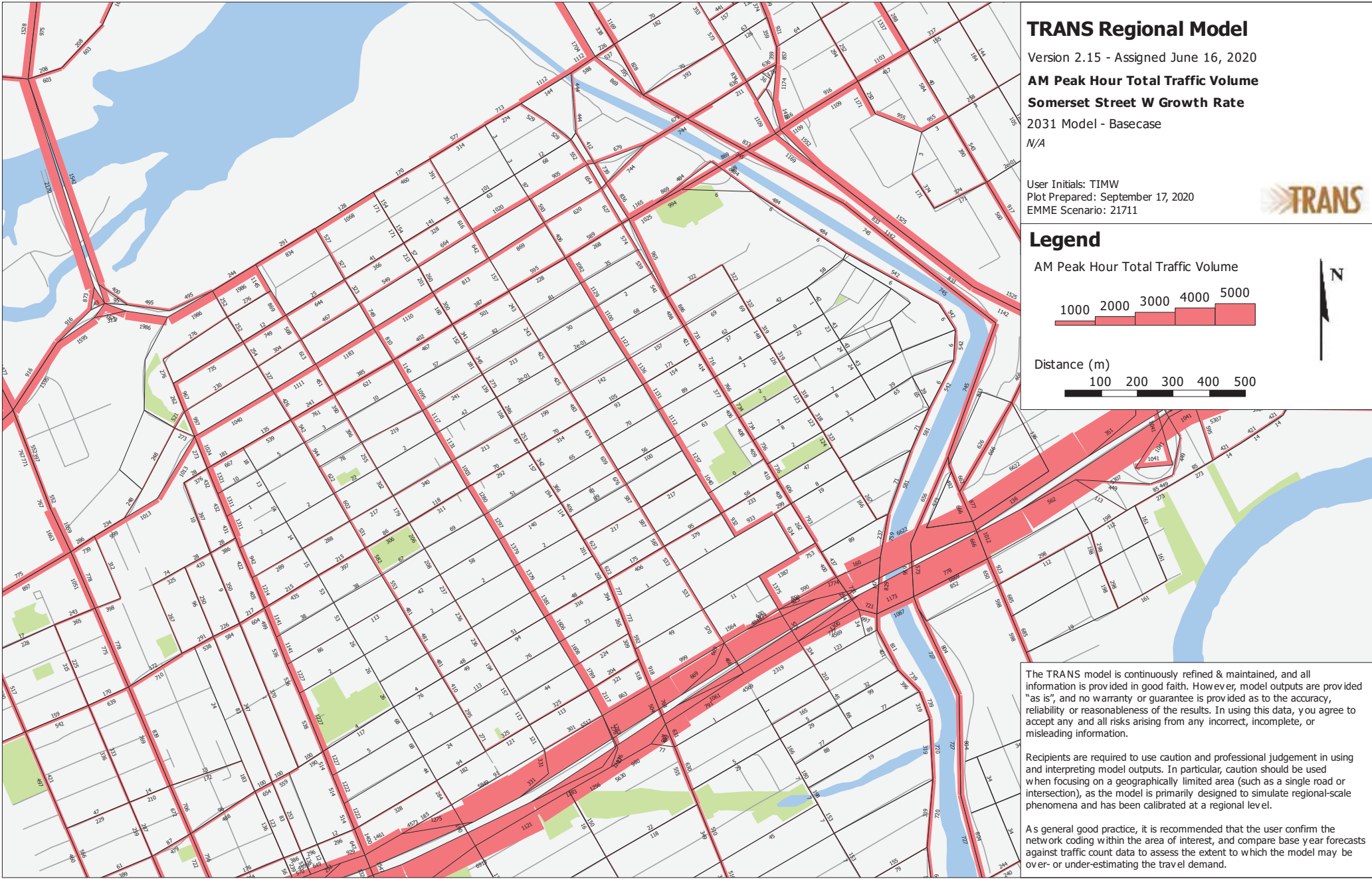

# TRANS Regional Model

Version 2.15 - Assigned June 16, 2020

**AM Peak Hour Total Traffic Volume**  
**Somerset Street W Growth Rate**

2031 Model - Basecase  
 N/A

User Initials: TIMW  
 Plot Prepared: September 17, 2020  
 EMME Scenario: 21711



## Legend

AM Peak Hour Total Traffic Volume

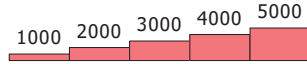

Distance (m)

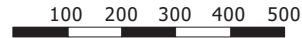

The TRANS model is continuously refined & maintained, and all information is provided in good faith. However, model outputs are provided "as is", and no warranty or guarantee is provided as to the accuracy, reliability or reasonableness of the results. In using this data, you agree to accept any and all risks arising from any incorrect, incomplete, or misleading information.

Recipients are required to use caution and professional judgement in using and interpreting model outputs. In particular, caution should be used when focusing on a geographically limited area (such as a single road or intersection), as the model is primarily designed to simulate regional-scale phenomena and has been calibrated at a regional level.

As a general good practice, it is recommended that the user confirm the network coding within the area of interest, and compare base year forecasts against traffic count data to assess the extent to which the model may be over- or under-estimating the travel demand.

# TRANS Regional Model

Version 2.15 - Assigned June 16, 2020

**AM Peak Hour Total Traffic Volume**

**Somerset Street W Growth Rate**

2011 Model - Basecase

N/A

User Initials: TIMW  
Plot Prepared: September 17, 2020  
EMME Scenario: 21711



## Legend

AM Peak Hour Total Traffic Volume

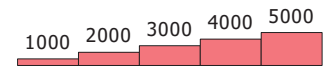

Distance (m)



The TRANS model is continuously refined & maintained, and all information is provided in good faith. However, model outputs are provided "as is", and no warranty or guarantee is provided as to the accuracy, reliability or reasonableness of the results. In using this data, you agree to accept any and all risks arising from any incorrect, incomplete, or misleading information.

Recipients are required to use caution and professional judgement in using and interpreting model outputs. In particular, caution should be used when focusing on a geographically limited area (such as a single road or intersection), as the model is primarily designed to simulate regional-scale phenomena and has been calibrated at a regional level.

As general good practice, it is recommended that the user confirm the network coding within the area of interest, and compare base year forecasts against traffic count data to assess the extent to which the model may be over- or under-estimating the travel demand.

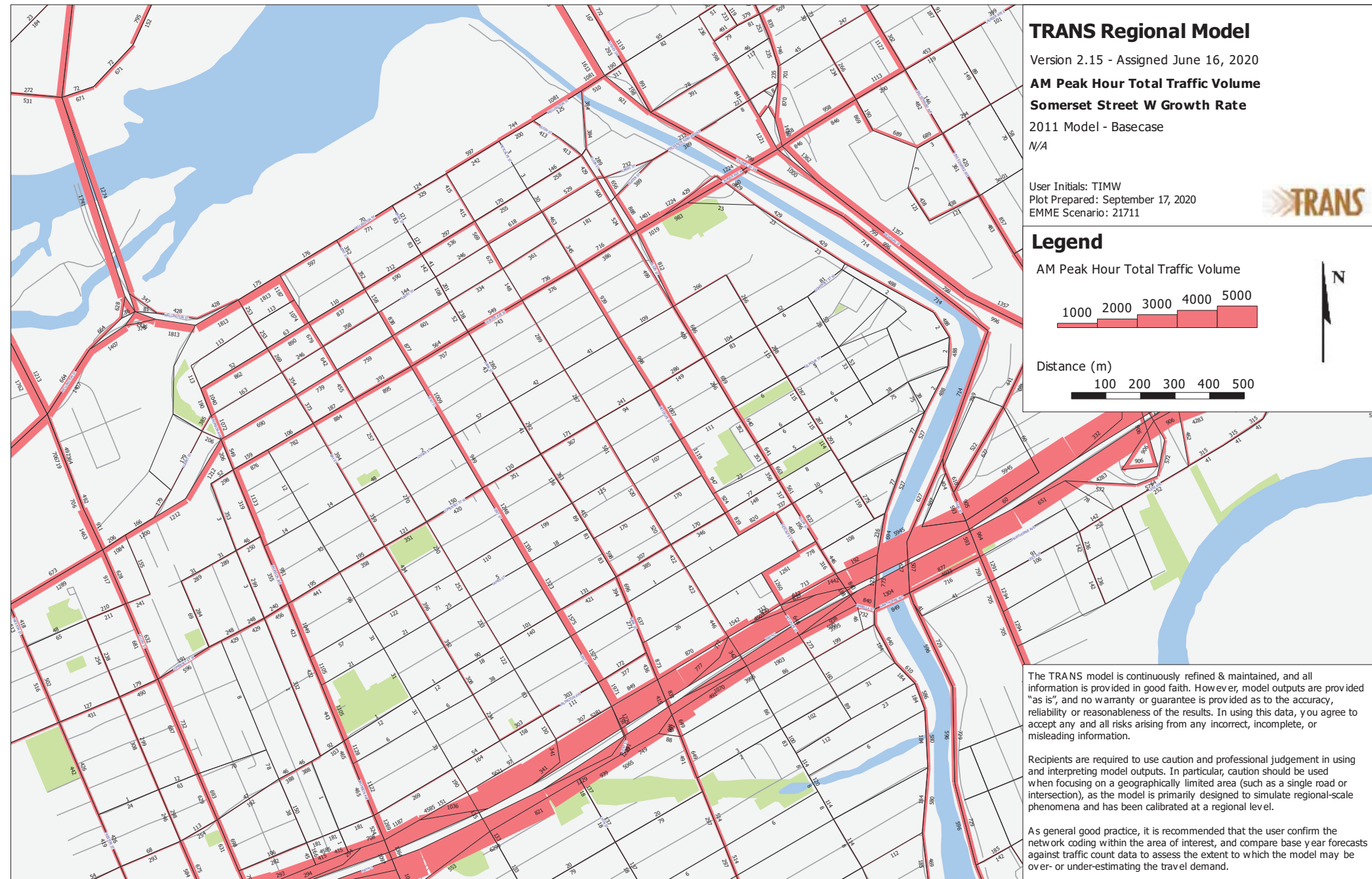

# Appendix F

Background Development Volumes

Figure 6: Site Generated Traffic

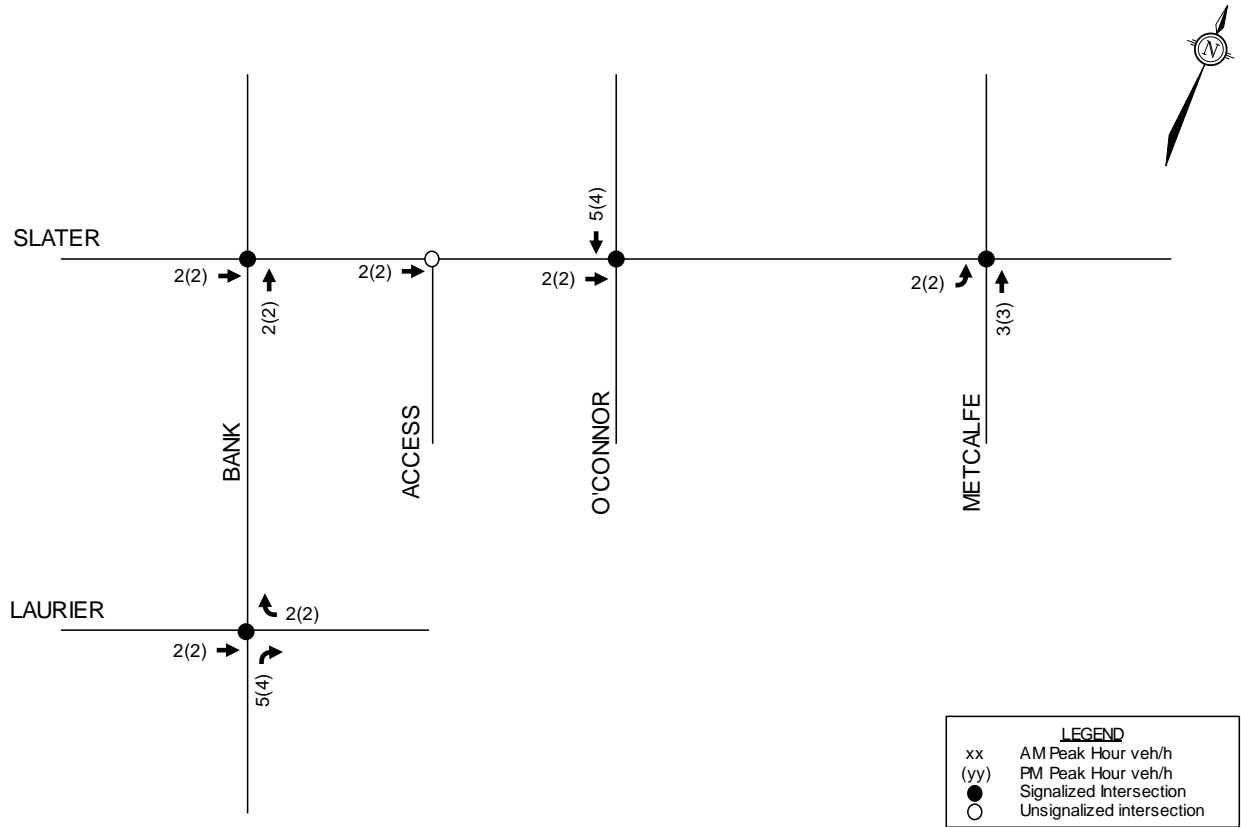



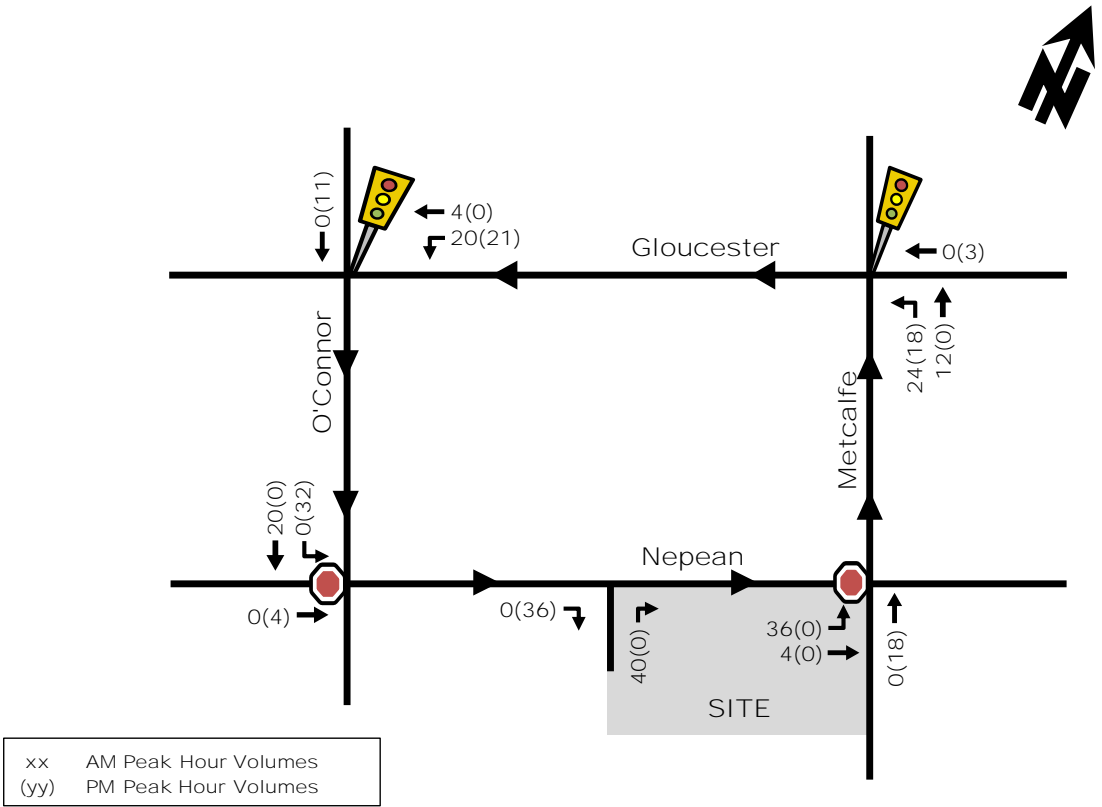

# Appendix G

Synchro Intersection Worksheets – 2027 Future Background Conditions

Lanes, Volumes, Timings  
1: O'Connor & Laurier

2027 Future Background  
AM Peak Hour

Lane Group	EBL	EBT	EBR	WBL	WBT	WBR	NBL	NBT	NBR	SBL	SBT	SBR
Lane Configurations		↔	↔	↔	↔						↔↔↔	
Traffic Volume (vph)	0	215	122	133	334	0	0	0	0	85	451	67
Future Volume (vph)	0	215	122	133	334	0	0	0	0	85	451	67
Satd. Flow (prot)	0	1430	0	1642	1712	0	0	0	0	0	4174	0
Flt Permitted				0.382							0.993	
Satd. Flow (perm)	0	1430	0	660	1712	0	0	0	0	0	3784	0
Satd. Flow (RTOR)												
Lane Group Flow (vph)	0	337	0	133	334	0	0	0	0	0	603	0
Turn Type		NA		pm+pt	NA					Perm	NA	
Protected Phases		2		9	6							4
Permitted Phases				6							4	
Detector Phase		2		9	6						4	4
Switch Phase												
Minimum Initial (s)		10.0		5.0	10.0					10.0	10.0	
Minimum Split (s)		23.9		10.8	21.9					22.5	22.5	
Total Split (s)		29.0		11.0	45.0					25.0	25.0	
Total Split (%)		38.7%		14.7%	60.0%					33.3%	33.3%	
Yellow Time (s)		3.3		3.3	3.3					3.3	3.3	
All-Red Time (s)		2.6		2.5	2.6					2.6	2.6	
Lost Time Adjust (s)		0.0		0.0	0.0						0.0	
Total Lost Time (s)		5.9		5.8	5.9						5.9	
Lead/Lag				Lead						Lag	Lag	
Lead-Lag Optimize?				Yes						Yes	Yes	
Recall Mode		C-Max		Max	C-Max					Max	Max	
Act Effct Green (s)		28.1		39.2	39.1						24.1	
Actuated g/C Ratio		0.37		0.52	0.52						0.32	
v/c Ratio		0.63		0.32	0.37						0.50	
Control Delay		25.6		7.1	6.7						22.3	
Queue Delay		0.0		0.0	0.0						0.0	
Total Delay		25.6		7.1	6.7						22.3	
LOS		C		A	A						C	
Approach Delay		25.6			6.8						22.3	
Approach LOS		C			A						C	
Queue Length 50th (m)		38.1		5.2	13.3						24.9	
Queue Length 95th (m)		64.6		9.3	19.7						34.9	
Internal Link Dist (m)		71.8			158.7			39.2			62.3	
Turn Bay Length (m)												
Base Capacity (vph)		535		413	892						1215	
Starvation Cap Reductn		0		0	0						0	
Spillback Cap Reductn		0		0	0						0	
Storage Cap Reductn		0		0	0						0	
Reduced v/c Ratio		0.63		0.32	0.37						0.50	

Intersection Summary	
Cycle Length: 75	
Actuated Cycle Length: 75	
Offset: 63 (84%), Referenced to phase 2:EBT and 6:WBTL, Start of Green	
Natural Cycle: 70	
Control Type: Actuated-Coordinated	

Lanes, Volumes, Timings  
1: O'Connor & Laurier

2027 Future Background  
AM Peak Hour

Lane Group	Ø1	Ø3
Lane Configurations		
Traffic Volume (vph)		
Future Volume (vph)		
Satd. Flow (prot)		
Flt Permitted		
Satd. Flow (perm)		
Satd. Flow (RTOR)		
Lane Group Flow (vph)		
Turn Type		
Protected Phases	1	3
Permitted Phases		
Detector Phase		
Switch Phase		
Minimum Initial (s)	1.0	1.0
Minimum Split (s)	5.0	5.0
Total Split (s)	5.0	5.0
Total Split (%)	7%	7%
Yellow Time (s)	2.0	2.0
All-Red Time (s)	0.0	0.0
Lost Time Adjust (s)		
Total Lost Time (s)		
Lead/Lag	Lag	Lead
Lead-Lag Optimize?	Yes	Yes
Recall Mode	None	None
Act Effct Green (s)		
Actuated g/C Ratio		
v/c Ratio		
Control Delay		
Queue Delay		
Total Delay		
LOS		
Approach Delay		
Approach LOS		
Queue Length 50th (m)		
Queue Length 95th (m)		
Internal Link Dist (m)		
Turn Bay Length (m)		
Base Capacity (vph)		
Starvation Cap Reductn		
Spillback Cap Reductn		
Storage Cap Reductn		
Reduced v/c Ratio		

Intersection Summary	
Cycle Length: 75	
Actuated Cycle Length: 75	
Offset: 63 (84%), Referenced to phase 2:EBT and 6:WBTL, Start of Green	
Natural Cycle: 70	
Control Type: Actuated-Coordinated	

Lanes, Volumes, Timings  
1: O'Connor & Laurier

2027 Future Background  
AM Peak Hour

Maximum v/c Ratio: 0.63	Intersection LOS: B
Intersection Signal Delay: 17.9	ICU Level of Service B
Intersection Capacity Utilization 61.2%	
Analysis Period (min) 15	

Splits and Phases: 1: O'Connor & Laurier

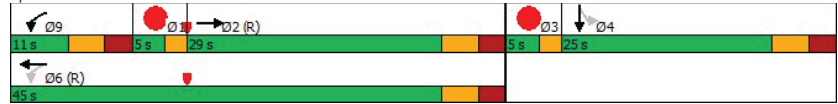

Lanes, Volumes, Timings  
2: Metcalfe & Laurier

2027 Future Background  
AM Peak Hour

Lane Group	EBL	EBT	EBR	WBL	WBT	WBR	NBL	NBT	NBR	SBL	SBT	SBR
Lane Configurations		↕			↕			↕				
Traffic Volume (vph)	22	288	0	0	391	256	96	671	74	0	0	0
Future Volume (vph)	22	288	0	0	391	256	96	671	74	0	0	0
Satd. Flow (prot)	0	1734	0	0	2511	0	0	4339	0	0	0	0
Flt Permitted		0.938						0.994				
Satd. Flow (perm)	0	1617	0	0	2511	0	0	4137	0	0	0	0
Satd. Flow (RTOR)												
Lane Group Flow (vph)	0	310	0	0	647	0	0	841	0	0	0	0
Turn Type	Perm	NA			NA		Perm	NA				
Protected Phases		2			6			4				
Permitted Phases	2						4					
Detector Phase	2	2			6		4	4				
Switch Phase												
Minimum Initial (s)	10.0	10.0			10.0		10.0	10.0				
Minimum Split (s)	37.0	37.0			37.0		33.0	33.0				
Total Split (s)	37.0	37.0			37.0		33.0	33.0				
Total Split (%)	49.3%	49.3%			49.3%		44.0%	44.0%				
Yellow Time (s)	3.3	3.3			3.3		3.3	3.3				
All-Red Time (s)	2.4	2.4			2.4		2.2	2.2				
Lost Time Adjust (s)		0.0			0.0			0.0				
Total Lost Time (s)		5.7			5.7			5.5				
Lead/Lag	Lag	Lag			Lag							
Lead-Lag Optimize?	Yes	Yes			Yes							
Recall Mode	C-Max	C-Max			C-Max		Max	Max				
Act Effct Green (s)		36.3			36.3			27.5				
Actuated g/C Ratio		0.48			0.48			0.37				
v/c Ratio		0.40			0.53			0.55				
Control Delay		19.1			15.5			15.2				
Queue Delay		0.0			0.0			0.4				
Total Delay		19.1			15.5			15.6				
LOS		B			B			B				
Approach Delay		19.1			15.5			15.6				
Approach LOS		B			B			B				
Queue Length 50th (m)		31.3			31.6			35.2				
Queue Length 95th (m)		56.3			46.1			47.1				
Internal Link Dist (m)		158.7			172.2			51.7			65.1	
Turn Bay Length (m)												
Base Capacity (vph)		782			1215			1516				
Starvation Cap Reductn		0			0			249				
Spillback Cap Reductn		0			0			0				
Storage Cap Reductn		0			0			0				
Reduced v/c Ratio		0.40			0.53			0.66				

Intersection Summary

Cycle Length: 75
Actuated Cycle Length: 75
Offset: 48 (64%), Referenced to phase 2:EBTL and 6:WBT, Start of Green
Natural Cycle: 75
Control Type: Actuated-Coordinated

Lane Group	Ø1	Ø5
Lane Configurations		
Traffic Volume (vph)		
Future Volume (vph)		
Satd. Flow (prot)		
Flt Permitted		
Satd. Flow (perm)		
Satd. Flow (RTOR)		
Lane Group Flow (vph)		
Turn Type		
Protected Phases	1	5
Permitted Phases		
Detector Phase		
Switch Phase		
Minimum Initial (s)	1.0	1.0
Minimum Split (s)	5.0	5.0
Total Split (s)	5.0	5.0
Total Split (%)	7%	7%
Yellow Time (s)	2.0	2.0
All-Red Time (s)	0.0	0.0
Lost Time Adjust (s)		
Total Lost Time (s)		
Lead/Lag	Lead	Lead
Lead-Lag Optimize?	Yes	Yes
Recall Mode	None	None
Act Effct Green (s)		
Actuated g/C Ratio		
v/c Ratio		
Control Delay		
Queue Delay		
Total Delay		
LOS		
Approach Delay		
Approach LOS		
Queue Length 50th (m)		
Queue Length 95th (m)		
Internal Link Dist (m)		
Turn Bay Length (m)		
Base Capacity (vph)		
Starvation Cap Reductn		
Spillback Cap Reductn		
Storage Cap Reductn		
Reduced v/c Ratio		
Intersection Summary		

Maximum v/c Ratio: 0.55	
Intersection Signal Delay: 16.2	Intersection LOS: B
Intersection Capacity Utilization 65.1%	ICU Level of Service C
Analysis Period (min) 15	



Lanes, Volumes, Timings  
3: Elgin & Laurier/City Hall

2027 Future Background  
AM Peak Hour

Lane Group	EBL	EBT	EBR	WBL	WBT	WBR	NBL	NBT	NBR	SBL	SBT	SBR
Lane Configurations		↑↑		↑	↑	↑		↑↑	↑	↑↑	↑↑	
Traffic Volume (vph)	0	285	57	209	497	538	0	208	59	361	367	170
Future Volume (vph)	0	285	57	209	497	538	0	208	59	361	367	170
Satd. Flow (prot)	0	3043	0	1658	1745	1483	0	3316	1483	3154	2423	0
Flt Permitted				0.532						0.950		
Satd. Flow (perm)	0	3043	0	771	1745	920	0	3316	680	1869	2423	0
Satd. Flow (RTOR)									149		95	
Lane Group Flow (vph)	0	342	0	209	497	538	0	208	59	361	537	0
Turn Type		NA		custom	NA	custom		NA	pm+ov	Prot	NA	
Protected Phases		2		9	5	6		3		9	3	8
Permitted Phases				6		6				4		
Detector Phase		2		9	5	6		3		4	9	3
Switch Phase												
Minimum Initial (s)		5.0		5.0		10.0		10.0	5.0	10.0	10.0	
Minimum Split (s)		30.0		12.0		20.7		28.2	12.0	20.7	28.2	
Total Split (s)		31.0		15.0		20.8		28.2	15.0	20.8	49.0	
Total Split (%)		31.0%		15.0%		20.8%		28.2%	15.0%	20.8%	49.0%	
Yellow Time (s)		3.3		3.3		3.3		3.3	3.3	3.3	3.3	
All-Red Time (s)		3.7		3.7		4.4		2.9	3.7	4.4	2.9	
Lost Time Adjust (s)		0.0		0.0		0.0		0.0	0.0	0.0	0.0	
Total Lost Time (s)		7.0		7.0		7.7		6.2	7.0	7.7	6.2	
Lead/Lag				Lead		Lead		Lag	Lead		Lead	
Lead-Lag Optimize?				Yes		Yes		Yes	Yes		Yes	
Recall Mode		C-Max		Max		None		Max	Max		None	Max
Act Effct Green (s)		29.0		37.0		49.0		22.0	29.2		13.1	42.8
Actuated g/C Ratio		0.29		0.37		0.49		0.22	0.29		0.13	0.43
v/c Ratio		0.39		0.59		0.58		0.29	0.16		0.87	0.49
Control Delay		30.0		27.2		21.6		33.7	0.9		65.4	18.6
Queue Delay		0.0		0.0		0.0		0.0	0.0		0.0	0.0
Total Delay		30.0		27.2		21.6		33.7	0.9		65.4	18.6
LOS		C		C		C		C	A		E	B
Approach Delay		30.0				28.6		26.5				37.4
Approach LOS		C				C		C				D
Queue Length 50th (m)		27.8		25.3		66.1		39.9		17.7	0.0	35.8
Queue Length 95th (m)		40.4		41.4		97.3		#89.7		27.8	0.0	#60.1
Internal Link Dist (m)		172.2				106.8				136.3		
Turn Bay Length (m)									90.0		85.0	
Base Capacity (vph)		882		356		855		594		729	368	413
Starvation Cap Reductn		0		0		0		0		0	0	0
Spillback Cap Reductn		0		0		0		0		0	0	0
Storage Cap Reductn		0		0		0		0		0	0	0
Reduced v/c Ratio		0.39		0.59		0.58		0.91		0.29	0.16	0.87

Intersection Summary

Cycle Length: 100  
 Actuated Cycle Length: 100  
 Offset: 64 (64%), Referenced to phase 2:EBT and 6:WBTL, Start of Green  
 Natural Cycle: 100  
 Control Type: Actuated-Coordinated

Lanes, Volumes, Timings  
3: Elgin & Laurier/City Hall

2027 Future Background  
AM Peak Hour

Lane Group	Ø1	Ø5	Ø6	Ø13
Lane Configurations				
Traffic Volume (vph)				
Future Volume (vph)				
Satd. Flow (prot)				
Flt Permitted				
Satd. Flow (perm)				
Satd. Flow (RTOR)				
Lane Group Flow (vph)				
Turn Type				
Protected Phases	1	5	6	13
Permitted Phases				
Detector Phase				
Switch Phase				
Minimum Initial (s)	1.0	1.0	5.0	1.0
Minimum Split (s)	5.0	7.0	25.0	5.0
Total Split (s)	5.0	10.0	36.0	5.0
Total Split (%)	5%	10%	36%	5%
Yellow Time (s)	2.0	2.0	2.0	2.0
All-Red Time (s)	0.0	0.0	0.0	0.0
Lost Time Adjust (s)				
Total Lost Time (s)				
Lead/Lag	Lag	Lag		Lead
Lead-Lag Optimize?	Yes	Yes		Yes
Recall Mode	None	None	C-Max	None
Act Effct Green (s)				
Actuated g/C Ratio				
v/c Ratio				
Control Delay				
Queue Delay				
Total Delay				
LOS				
Approach Delay				
Approach LOS				
Queue Length 50th (m)				
Queue Length 95th (m)				
Internal Link Dist (m)				
Turn Bay Length (m)				
Base Capacity (vph)				
Starvation Cap Reductn				
Spillback Cap Reductn				
Storage Cap Reductn				
Reduced v/c Ratio				

Intersection Summary

Lanes, Volumes, Timings  
3: Elgin & Laurier/City Hall

2027 Future Background  
AM Peak Hour

Maximum v/c Ratio: 0.91	Intersection LOS: C
Intersection Signal Delay: 31.4	ICU Level of Service E
Intersection Capacity Utilization 83.8%	
Analysis Period (min) 15	
# 95th percentile volume exceeds capacity, queue may be longer.	
Queue shown is maximum after two cycles.	

Splits and Phases: 3: Elgin & Laurier/City Hall

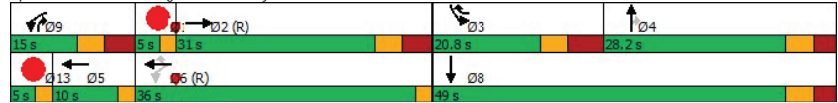

Lanes, Volumes, Timings  
4: Metcalfe & Gloucester

2027 Future Background  
AM Peak Hour

Lane Group	EBL	EBT	EBR	WBL	WBT	WBR	NBL	NBT	NBR	SBL	SBT	SBR
Lane Configurations					↑↑			↑↑↑				
Traffic Volume (vph)	0	0	0	0	164	74	247	772	0	0	0	0
Future Volume (vph)	0	0	0	0	164	74	247	772	0	0	0	0
Satd. Flow (prot)	0	0	0	0	2845	0	0	4696	0	0	0	0
Flt Permitted								0.988				
Satd. Flow (perm)	0	0	0	0	2845	0	0	4315	0	0	0	0
Satd. Flow (RTOR)					29			89				
Lane Group Flow (vph)	0	0	0	0	238	0	0	1019	0	0	0	0
Turn Type					NA			Perm	NA			
Protected Phases					4			2				
Permitted Phases								2				
Detector Phase					4			2	2			
Switch Phase												
Minimum Initial (s)					10.0			10.0	10.0			
Minimum Split (s)					23.1			35.0	35.0			
Total Split (s)					25.0			50.0	50.0			
Total Split (%)					33.3%			66.7%	66.7%			
Yellow Time (s)					3.3			3.3	3.3			
All-Red Time (s)					1.8			1.7	1.7			
Lost Time Adjust (s)					0.0			0.0	0.0			
Total Lost Time (s)					5.1			5.0	5.0			
Lead/Lag												
Lead-Lag Optimize?												
Recall Mode					Max			C-Max	C-Max			
Act Effct Green (s)					19.9			35.0	45.0			
Actuated g/C Ratio					0.27			0.60	0.60			
v/c Ratio					0.31			0.39	0.39			
Control Delay					20.5			7.6	7.6			
Queue Delay					0.0			0.0	0.0			
Total Delay					20.5			7.6	7.6			
LOS					C			A	A			
Approach Delay					20.5			7.6	7.6			
Approach LOS					C			A	A			
Queue Length 50th (m)					12.3			22.0	22.0			
Queue Length 95th (m)					21.3			29.5	29.5			
Internal Link Dist (m)						34.9		48.3	35.0			51.7
Turn Bay Length (m)												
Base Capacity (vph)					776			2624	2624			
Starvation Cap Reductn					0			0	0			
Spillback Cap Reductn					0			105	105			
Storage Cap Reductn					0			0	0			
Reduced v/c Ratio					0.31			0.40	0.40			

Intersection Summary

Cycle Length: 75
Actuated Cycle Length: 75
Offset: 73 (97%), Referenced to phase 2:NBTL, Start of Green
Natural Cycle: 60
Control Type: Actuated-Coordinated

Lanes, Volumes, Timings  
4: Metcalfe & Gloucester

2027 Future Background  
AM Peak Hour

Maximum v/c Ratio: 0.39	Intersection LOS: B
Intersection Signal Delay: 10.0	ICU Level of Service A
Intersection Capacity Utilization 43.3%	
Analysis Period (min) 15	

Splits and Phases: 4: Metcalfe & Gloucester



Lanes, Volumes, Timings  
5: Elgin & Nepean/City Hall

2027 Future Background  
AM Peak Hour

Lane Group	EBL	EBT	EBR	WBL	WBT	WBR	NBL	NBT	NBR	SBL	SBT	SBR
Lane Configurations		↔		↔		↔		↔		↔	↔	↔
Traffic Volume (vph)	31	7	31	1	0	9	0	274	43	17	328	0
Future Volume (vph)	31	7	31	1	0	9	0	274	43	17	328	0
Satd. Flow (prot)	0	1506	0	1658	0	1483	0	3077	0	1658	3252	0
Flt Permitted		0.978		0.712						0.560		
Satd. Flow (perm)	0	1427	0	1188	0	1294	0	3077	0	855	3252	0
Satd. Flow (RTOR)		31				53		33				
Lane Group Flow (vph)	0	69	0	1	0	9	0	317	0	17	328	0
Turn Type	Perm	NA	Perm	Perm	Perm	NA	Perm	NA	Perm	NA	NA	NA
Protected Phases		4						2				6
Permitted Phases	4			8		8				6		
Detector Phase	4	4		8		8		2		6		6
Switch Phase												
Minimum Initial (s)	10.0	10.0		10.0		10.0		10.0		10.0		10.0
Minimum Split (s)	25.1	25.1		25.1		25.1		31.4		31.4		31.4
Total Split (s)	27.0	27.0		27.0		27.0		58.0		58.0		58.0
Total Split (%)	30.0%	30.0%		30.0%		30.0%		64.4%		64.4%		64.4%
Yellow Time (s)	3.3	3.3		3.3		3.3		3.3		3.3		3.3
All-Red Time (s)	2.8	2.8		2.8		2.8		2.1		2.1		2.1
Lost Time Adjust (s)		0.0		0.0		0.0		0.0		0.0		0.0
Total Lost Time (s)		6.1		6.1		6.1		5.4		5.4		5.4
Lead/Lag	Lag	Lag		Lag		Lag						
Lead-Lag Optimize?	Yes	Yes		Yes		Yes						
Recall Mode	Max	Max		Max		Max		C-Max		C-Max		C-Max
Act Effct Green (s)		25.9		25.9		25.9		52.6		52.6		52.6
Actuated g/C Ratio		0.29		0.29		0.29		0.58		0.58		0.58
v/c Ratio		0.16		0.00		0.02		0.17		0.03		0.17
Control Delay		16.1		23.0		0.1		8.0		8.2		8.9
Queue Delay		0.0		0.0		0.0		0.0		0.0		0.0
Total Delay		16.1		23.0		0.1		8.0		8.2		8.9
LOS		B		C		A		A		A		A
Approach Delay		16.1				2.4		8.0				8.9
Approach LOS		B				A		A				A
Queue Length 50th (m)		4.8		0.1		0.0		10.9		1.2		12.7
Queue Length 95th (m)		14.5		1.3		0.0		16.9		3.8		18.8
Internal Link Dist (m)		54.5				21.0		120.5				136.3
Turn Bay Length (m)										20.0		
Base Capacity (vph)		432		341		410		1812		499		1900
Starvation Cap Reductn		0		0		0		0		0		0
Spillback Cap Reductn		0		0		0		0		0		0
Storage Cap Reductn		0		0		0		0		0		0
Reduced v/c Ratio		0.16		0.00		0.02		0.17		0.03		0.17

Intersection Summary

Cycle Length: 90
Actuated Cycle Length: 90
Offset: 0 (0%), Referenced to phase 2:NBT and 6:SBTL, Start of Green
Natural Cycle: 65
Control Type: Actuated-Coordinated



Lanes, Volumes, Timings  
5: Elgin & Nepean/City Hall

2027 Future Background  
AM Peak Hour

Lane Group	Ø3	Ø7
Lane Configurations		
Traffic Volume (vph)		
Future Volume (vph)		
Satd. Flow (prot)		
Flt Permitted		
Satd. Flow (perm)		
Satd. Flow (RTOR)		
Lane Group Flow (vph)		
Turn Type		
Protected Phases	3	7
Permitted Phases		
Detector Phase		
Switch Phase		
Minimum Initial (s)	1.0	1.0
Minimum Split (s)	5.0	5.0
Total Split (s)	5.0	5.0
Total Split (%)	6%	6%
Yellow Time (s)	2.0	2.0
All-Red Time (s)	0.0	0.0
Lost Time Adjust (s)		
Total Lost Time (s)		
Lead/Lag	Lead	Lead
Lead-Lag Optimize?	Yes	Yes
Recall Mode	None	None
Act Effct Green (s)		
Actuated g/C Ratio		
v/c Ratio		
Control Delay		
Queue Delay		
Total Delay		
LOS		
Approach Delay		
Approach LOS		
Queue Length 50th (m)		
Queue Length 95th (m)		
Internal Link Dist (m)		
Turn Bay Length (m)		
Base Capacity (vph)		
Starvation Cap Reductn		
Spillback Cap Reductn		
Storage Cap Reductn		
Reduced v/c Ratio		
Intersection Summary		

Lanes, Volumes, Timings  
5: Elgin & Nepean/City Hall

2027 Future Background  
AM Peak Hour

Maximum v/c Ratio: 0.17	
Intersection Signal Delay: 9.1	Intersection LOS: A
Intersection Capacity Utilization 66.3%	ICU Level of Service C
Analysis Period (min) 15	

Splits and Phases: 5: Elgin & Nepean/City Hall

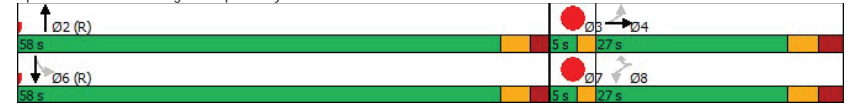

Lanes, Volumes, Timings  
1: O'Connor & Laurier

2027 Future Background  
PM Peak Hour

Lane Group	EBL	EBT	EBR	WBL	WBT	WBR	NBL	NBT	NBR	SBL	SBT	SBR
Lane Configurations		↔	↔	↔	↔						↕	↕
Traffic Volume (vph)	0	204	95	179	273	0	0	0	0	51	544	44
Future Volume (vph)	0	204	95	179	273	0	0	0	0	51	544	44
Satd. Flow (prot)	0	1472	0	1642	1745	0	0	0	0	0	4480	0
Flt Permitted				0.386							0.996	
Satd. Flow (perm)	0	1472	0	667	1745	0	0	0	0	0	4249	0
Satd. Flow (RTOR)												
Lane Group Flow (vph)	0	333	0	199	303	0	0	0	0	0	710	0
Turn Type		NA		pm+pt	NA					Perm	NA	
Protected Phases		2		9	6							4
Permitted Phases				6							4	
Detector Phase		2		9	6						4	4
Switch Phase												
Minimum Initial (s)		10.0		5.0	10.0					10.0	10.0	
Minimum Split (s)		23.9		10.8	21.9					22.5	22.5	
Total Split (s)		29.0		11.0	45.0					25.0	25.0	
Total Split (%)		38.7%		14.7%	60.0%					33.3%	33.3%	
Yellow Time (s)		3.3		3.3	3.3					3.3	3.3	
All-Red Time (s)		2.6		2.5	2.6					2.6	2.6	
Lost Time Adjust (s)		0.0		0.0	0.0						0.0	
Total Lost Time (s)		5.9		5.8	5.9						5.9	
Lead/Lag				Lead						Lag	Lag	
Lead-Lag Optimize?				Yes						Yes	Yes	
Recall Mode		C-Max		Max	C-Max					Max	Max	
Act Effct Green (s)		28.1		39.2	39.1						24.1	
Actuated g/C Ratio		0.37		0.52	0.52						0.32	
v/c Ratio		0.60		0.48	0.33						0.52	
Control Delay		24.6		22.1	16.2						22.4	
Queue Delay		0.0		0.0	0.0						0.0	
Total Delay		24.6		22.1	16.2						22.4	
LOS		C		C	B						C	
Approach Delay		24.6			18.6						22.4	
Approach LOS		C			B						C	
Queue Length 50th (m)		37.2		18.6	25.8						29.6	
Queue Length 95th (m)		62.9		37.2	46.7						40.4	
Internal Link Dist (m)		71.8			158.7			39.2			62.3	
Turn Bay Length (m)												
Base Capacity (vph)		551		416	909						1365	
Starvation Cap Reductn		0		0	0						0	
Spillback Cap Reductn		0		0	0						0	
Storage Cap Reductn		0		0	0						0	
Reduced v/c Ratio		0.60		0.48	0.33						0.52	

Intersection Summary	
Cycle Length: 75	
Actuated Cycle Length: 75	
Offset: 22 (29%), Referenced to phase 2:EBT and 6:WBTL, Start of Green	
Natural Cycle: 70	
Control Type: Actuated-Coordinated	

Lanes, Volumes, Timings  
1: O'Connor & Laurier

2027 Future Background  
PM Peak Hour

Lane Group	Ø1	Ø3
Lane Configurations		
Traffic Volume (vph)		
Future Volume (vph)		
Satd. Flow (prot)		
Flt Permitted		
Satd. Flow (perm)		
Satd. Flow (RTOR)		
Lane Group Flow (vph)		
Turn Type		
Protected Phases	1	3
Permitted Phases		
Detector Phase		
Switch Phase		
Minimum Initial (s)	1.0	1.0
Minimum Split (s)	5.0	5.0
Total Split (s)	5.0	5.0
Total Split (%)	7%	7%
Yellow Time (s)	2.0	2.0
All-Red Time (s)	0.0	0.0
Lost Time Adjust (s)		
Total Lost Time (s)		
Lead/Lag	Lag	Lead
Lead-Lag Optimize?	Yes	Yes
Recall Mode	None	None
Act Effct Green (s)		
Actuated g/C Ratio		
v/c Ratio		
Control Delay		
Queue Delay		
Total Delay		
LOS		
Approach Delay		
Approach LOS		
Queue Length 50th (m)		
Queue Length 95th (m)		
Internal Link Dist (m)		
Turn Bay Length (m)		
Base Capacity (vph)		
Starvation Cap Reductn		
Spillback Cap Reductn		
Storage Cap Reductn		
Reduced v/c Ratio		

Intersection Summary	

Lanes, Volumes, Timings  
1: O'Connor & Laurier

2027 Future Background  
PM Peak Hour

Maximum v/c Ratio: 0.60	Intersection LOS: C
Intersection Signal Delay: 21.6	ICU Level of Service B
Intersection Capacity Utilization 61.4%	
Analysis Period (min) 15	

Splits and Phases: 1: O'Connor & Laurier

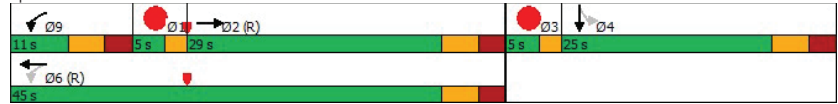

Lanes, Volumes, Timings  
2: Metcalfe & Laurier

2027 Future Background  
PM Peak Hour

Lane Group	EBL	EBT	EBR	WBL	WBT	WBR	NBL	NBT	NBR	SBL	SBT	SBR
Lane Configurations		↕			↕			↕				
Traffic Volume (vph)	10	245	0	0	392	166	33	395	126	0	0	0
Future Volume (vph)	10	245	0	0	392	166	33	395	126	0	0	0
Satd. Flow (prot)	0	1742	0	0	2811	0	0	3749	0	0	0	0
Flt Permitted		0.974			0.997							
Satd. Flow (perm)	0	1691	0	0	2811	0	0	3666	0	0	0	0
Satd. Flow (RTOR)												
Lane Group Flow (vph)	0	283	0	0	620	0	0	616	0	0	0	0
Turn Type	Perm	NA			NA		Perm	NA				
Protected Phases		2			6			4				
Permitted Phases	2						4					
Detector Phase	2	2			6		4	4				
Switch Phase												
Minimum Initial (s)	10.0	10.0			10.0		10.0	10.0				
Minimum Split (s)	37.0	37.0			37.0		19.5	19.5				
Total Split (s)	40.0	40.0			40.0		30.0	30.0				
Total Split (%)	53.3%	53.3%			53.3%		40.0%	40.0%				
Yellow Time (s)	3.3	3.3			3.3		3.3	3.3				
All-Red Time (s)	2.4	2.4			2.4		2.2	2.2				
Lost Time Adjust (s)		0.0			0.0			0.0				
Total Lost Time (s)		5.7			5.7			5.5				
Lead/Lag	Lag	Lag			Lag							
Lead-Lag Optimize?	Yes	Yes			Yes							
Recall Mode	C-Max	C-Max			C-Max		Max	Max				
Act Effct Green (s)		39.3			39.3			24.5				
Actuated g/C Ratio		0.52			0.52			0.33				
v/c Ratio		0.32			0.42			0.51				
Control Delay		6.6			12.0			17.8				
Queue Delay		0.0			0.0			0.3				
Total Delay		6.6			12.0			18.1				
LOS		A			B			B				
Approach Delay		6.6			12.0			18.1				
Approach LOS		A			B			B				
Queue Length 50th (m)		8.9			26.2			16.7				
Queue Length 95th (m)		13.5			37.8			21.5				
Internal Link Dist (m)		158.7			172.2			51.7			65.1	
Turn Bay Length (m)												
Base Capacity (vph)		886			1472			1197				
Starvation Cap Reductn		0			0			175				
Spillback Cap Reductn		0			0			0				
Storage Cap Reductn		0			0			0				
Reduced v/c Ratio		0.32			0.42			0.60				

Intersection Summary

Cycle Length: 75
Actuated Cycle Length: 75
Offset: 30 (40%), Referenced to phase 2:EBTL and 6:WBT, Start of Green
Natural Cycle: 65
Control Type: Actuated-Coordinated

Lane Group	Ø1	Ø5
Lane Configurations		
Traffic Volume (vph)		
Future Volume (vph)		
Satd. Flow (prot)		
Flt Permitted		
Satd. Flow (perm)		
Satd. Flow (RTOR)		
Lane Group Flow (vph)		
Turn Type		
Protected Phases	1	5
Permitted Phases		
Detector Phase		
Switch Phase		
Minimum Initial (s)	1.0	1.0
Minimum Split (s)	5.0	5.0
Total Split (s)	5.0	5.0
Total Split (%)	7%	7%
Yellow Time (s)	2.0	2.0
All-Red Time (s)	0.0	0.0
Lost Time Adjust (s)		
Total Lost Time (s)		
Lead/Lag	Lead	Lead
Lead-Lag Optimize?	Yes	Yes
Recall Mode	None	None
Act Effct Green (s)		
Actuated g/C Ratio		
v/c Ratio		
Control Delay		
Queue Delay		
Total Delay		
LOS		
Approach Delay		
Approach LOS		
Queue Length 50th (m)		
Queue Length 95th (m)		
Internal Link Dist (m)		
Turn Bay Length (m)		
Base Capacity (vph)		
Starvation Cap Reductn		
Spillback Cap Reductn		
Storage Cap Reductn		
Reduced v/c Ratio		
Intersection Summary		

Maximum v/c Ratio: 0.51	
Intersection Signal Delay: 13.5	Intersection LOS: B
Intersection Capacity Utilization 48.0%	ICU Level of Service A
Analysis Period (min) 15	

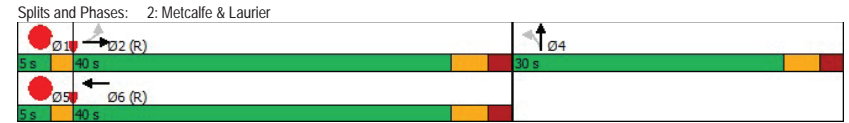

Lanes, Volumes, Timings  
3: Elgin & Laurier

2027 Future Background  
PM Peak Hour

Lane Group	EBL	EBT	EBR	WBL	WBT	WBR	NBL	NBT	NBR	SBL	SBT	SBR
Lane Configurations		↕		↕	↕	↕		↕	↕	↕	↕	↕
Traffic Volume (vph)	0	362	29	117	429	413	0	273	161	382	354	108
Future Volume (vph)	0	362	29	117	429	413	0	273	161	382	354	108
Satd. Flow (prot)	0	3205	0	1642	1745	1483	0	3316	1483	3154	2636	0
Flt Permitted				0.465						0.950		
Satd. Flow (perm)	0	3205	0	696	1745	976	0	3316	680	2237	2636	0
Satd. Flow (RTOR)						214			149		51	
Lane Group Flow (vph)	0	434	0	130	477	459	0	303	179	424	513	0
Turn Type		NA		custom	NA	custom		NA	pm+ov	Prot	NA	
Protected Phases		2		9	5	6		3	4	9	3	8
Permitted Phases				6		6			4			
Detector Phase		2		9	5	6		3	4	9	3	8
Switch Phase												
Minimum Initial (s)		5.0		5.0		10.0		10.0	5.0	10.0		10.0
Minimum Split (s)		30.0		12.0		20.7		28.2	12.0	20.7		28.2
Total Split (s)		31.0		14.0		21.8		28.2	14.0	21.8		50.0
Total Split (%)		31.0%		14.0%		21.8%		28.2%	14.0%	21.8%		50.0%
Yellow Time (s)		3.3		3.3		3.3		3.3	3.3	3.3		3.3
All-Red Time (s)		3.7		3.7		4.4		2.9	3.7	4.4		2.9
Lost Time Adjust (s)		0.0		0.0		0.0		0.0	0.0	0.0		0.0
Total Lost Time (s)		7.0		7.0		7.7		6.2	7.0	7.7		6.2
Lead/Lag				Lead		Lead		Lag	Lead		Lead	
Lead-Lag Optimize?				Yes		Yes		Yes	Yes		Yes	
Recall Mode		C-Max		None		None		Max	None	None		Max
Act Effct Green (s)		29.0		35.0		48.0		22.0	28.2	14.1		43.8
Actuated g/C Ratio		0.29		0.35		0.48		0.22	0.28	0.14		0.44
v/c Ratio		0.47		0.42		0.57		0.42	0.51	0.95		0.43
Control Delay		31.2		23.1		22.0		25.2	8.5	76.6		18.8
Queue Delay		0.0		0.0		0.0		0.0	0.0	0.0		0.0
Total Delay		31.2		23.1		22.0		25.2	8.5	76.6		18.8
LOS		C		C		C		C	A	E		B
Approach Delay		31.2				21.8		19.0				44.9
Approach LOS		C				C		B				D
Queue Length 50th (m)		36.3		15.2		63.8		16.1	1.3	42.6		31.6
Queue Length 95th (m)		50.7		27.2		94.4		23.2	9.0	71.4		45.1
Internal Link Dist (m)		172.2				106.8			136.3			52.8
Turn Bay Length (m)									90.0	85.0		
Base Capacity (vph)		930		309		837		729	354	444		1183
Starvation Cap Reductn		0		0		0		0	0	0		0
Spillback Cap Reductn		0		0		0		0	0	0		0
Storage Cap Reductn		0		0		0		0	0	0		0
Reduced v/c Ratio		0.47		0.42		0.57		0.42	0.51	0.95		0.43

Intersection Summary	
Cycle Length: 100	
Actuated Cycle Length: 100	
Offset: 52 (52%), Referenced to phase 2:EBT and 6:WBTL, Start of Green	
Natural Cycle: 100	
Control Type: Actuated-Coordinated	

Lanes, Volumes, Timings  
3: Elgin & Laurier

2027 Future Background  
PM Peak Hour

Lane Group	Ø1	Ø5	Ø6	Ø13
Lane Configurations				
Traffic Volume (vph)				
Future Volume (vph)				
Satd. Flow (prot)				
Flt Permitted				
Satd. Flow (perm)				
Satd. Flow (RTOR)				
Lane Group Flow (vph)				
Turn Type				
Protected Phases	1	5	6	13
Permitted Phases				
Detector Phase				
Switch Phase				
Minimum Initial (s)	1.0	1.0	5.0	1.0
Minimum Split (s)	5.0	7.0	25.0	5.0
Total Split (s)	5.0	10.0	35.0	5.0
Total Split (%)	5%	10%	35%	5%
Yellow Time (s)	2.0	2.0	2.0	2.0
All-Red Time (s)	0.0	0.0	0.0	0.0
Lost Time Adjust (s)				
Total Lost Time (s)				
Lead/Lag	Lag	Lag		Lead
Lead-Lag Optimize?	Yes	Yes		Yes
Recall Mode	None	None	C-Max	None
Act Effct Green (s)				
Actuated g/C Ratio				
v/c Ratio				
Control Delay				
Queue Delay				
Total Delay				
LOS				
Approach Delay				
Approach LOS				
Queue Length 50th (m)				
Queue Length 95th (m)				
Internal Link Dist (m)				
Turn Bay Length (m)				
Base Capacity (vph)				
Starvation Cap Reductn				
Spillback Cap Reductn				
Storage Cap Reductn				
Reduced v/c Ratio				

Intersection Summary	
Cycle Length: 100	
Actuated Cycle Length: 100	
Offset: 52 (52%), Referenced to phase 2:EBT and 6:WBTL, Start of Green	
Natural Cycle: 100	
Control Type: Actuated-Coordinated	

Lanes, Volumes, Timings  
3: Elgin & Laurier

2027 Future Background  
PM Peak Hour

Maximum v/c Ratio: 0.95	Intersection LOS: C
Intersection Signal Delay: 30.2	ICU Level of Service D
Intersection Capacity Utilization 79.1%	
Analysis Period (min) 15	
# 95th percentile volume exceeds capacity, queue may be longer.	
Queue shown is maximum after two cycles.	

Splits and Phases: 3: Elgin & Laurier

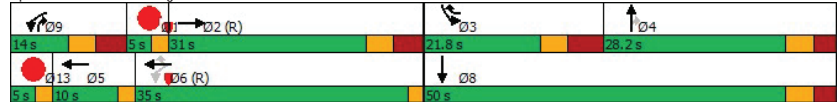

Lanes, Volumes, Timings  
4: Metcalfe & Gloucester

2027 Future Background  
PM Peak Hour

Lane Group	EBL	EBT	EBR	WBL	WBT	WBR	NBL	NBT	NBR	SBL	SBT	SBR
Lane Configurations					↑↑			↑↑↑				
Traffic Volume (vph)	0	0	0	0	209	127	114	420	0	0	0	0
Future Volume (vph)	0	0	0	0	209	127	114	420	0	0	0	0
Satd. Flow (prot)	0	0	0	0	2923	0	0	4712	0	0	0	0
Flt Permitted								0.989				
Satd. Flow (perm)	0	0	0	0	2923	0	0	4395	0	0	0	0
Satd. Flow (RTOR)					17			92				
Lane Group Flow (vph)	0	0	0	0	373	0	0	594	0	0	0	0
Turn Type					NA			Perm	NA			
Protected Phases					4			2				
Permitted Phases								2				
Detector Phase					4			2	2			
Switch Phase												
Minimum Initial (s)					10.0			10.0	10.0			
Minimum Split (s)					23.1			35.0	35.0			
Total Split (s)					30.0			45.0	45.0			
Total Split (%)					40.0%			60.0%	60.0%			
Yellow Time (s)					3.3			3.3	3.3			
All-Red Time (s)					1.8			1.7	1.7			
Lost Time Adjust (s)					0.0			0.0	0.0			
Total Lost Time (s)					5.1			5.0	5.0			
Lead/Lag												
Lead-Lag Optimize?												
Recall Mode					Max			C-Max	C-Max			
Act Effct Green (s)					24.9			35.0	40.0			
Actuated g/C Ratio					0.33			0.53	0.53			
v/c Ratio					0.38			0.25	0.25			
Control Delay					19.6			8.2	8.2			
Queue Delay					0.0			0.0	0.0			
Total Delay					19.6			8.2	8.2			
LOS					B			A	A			
Approach Delay					19.6			8.2	8.2			
Approach LOS					B			A	A			
Queue Length 50th (m)					19.8			12.7	12.7			
Queue Length 95th (m)					30.8			18.4	18.4			
Internal Link Dist (m)					34.9			48.3	35.0			51.7
Turn Bay Length (m)												
Base Capacity (vph)					981			2386	2386			
Starvation Cap Reductn					0			0	0			
Spillback Cap Reductn					0			0	0			
Storage Cap Reductn					0			0	0			
Reduced v/c Ratio					0.38			0.25	0.25			

Intersection Summary

Cycle Length: 75
Actuated Cycle Length: 75
Offset: 67 (89%), Referenced to phase 2:NBTL, Start of Green
Natural Cycle: 60
Control Type: Actuated-Coordinated

Lanes, Volumes, Timings  
4: Metcalfe & Gloucester

2027 Future Background  
PM Peak Hour

Maximum v/c Ratio: 0.38	Intersection LOS: B
Intersection Signal Delay: 12.6	ICU Level of Service A
Intersection Capacity Utilization 41.9%	
Analysis Period (min) 15	



Lanes, Volumes, Timings  
5: Elgin & Nepean/City Hall

2027 Future Background  
PM Peak Hour

Lane Group	EBL	EBT	EBR	WBL	WBT	WBR	NBL	NBT	NBR	SBL	SBT	SBR
Lane Configurations		↔		↔		↔		↔		↔	↔	↔
Traffic Volume (vph)	113	1	107	31	0	23	0	320	5	7	452	0
Future Volume (vph)	113	1	107	31	0	23	0	320	5	7	452	0
Satd. Flow (prot)	0	1491	0	1658	0	1483	0	3260	0	1658	3316	0
Flt Permitted		0.975		0.605						0.522		
Satd. Flow (perm)	0	1397	0	983	0	1286	0	3260	0	751	3316	0
Satd. Flow (RTOR)		55				48		2				
Lane Group Flow (vph)	0	246	0	34	0	26	0	362	0	8	502	0
Turn Type	Perm	NA	Perm	Perm	Perm	NA	Perm	NA	Perm	NA	NA	NA
Protected Phases		4						2			6	
Permitted Phases	4			8		8				6		
Detector Phase	4	4		8		8		2		6	6	
Switch Phase												
Minimum Initial (s)	10.0	10.0		10.0		10.0		10.0		10.0	10.0	
Minimum Split (s)	25.1	25.1		25.1		25.1		31.4		31.4	31.4	
Total Split (s)	45.0	45.0		45.0		45.0		50.0		50.0	50.0	
Total Split (%)	45.0%	45.0%		45.0%		45.0%		50.0%		50.0%	50.0%	
Yellow Time (s)	3.3	3.3		3.3		3.3		3.3		3.3	3.3	
All-Red Time (s)	2.8	2.8		2.8		2.8		2.1		2.1	2.1	
Lost Time Adjust (s)		0.0		0.0		0.0		0.0		0.0	0.0	
Total Lost Time (s)		6.1		6.1		6.1		5.4		5.4	5.4	
Lead/Lag	Lag	Lag		Lag		Lag						
Lead-Lag Optimize?	Yes	Yes		Yes		Yes						
Recall Mode	Max	Max		Max		Max		C-Max		C-Max	C-Max	
Act Effct Green (s)		43.9		43.9		43.9		44.6		44.6	44.6	
Actuated g/C Ratio		0.44		0.44		0.44		0.45		0.45	0.45	
v/c Ratio		0.38		0.08		0.04		0.25		0.02	0.34	
Control Delay		16.5		17.1		2.0		17.7		13.9	18.0	
Queue Delay		0.0		0.0		0.0		0.0		0.0	0.0	
Total Delay		16.5		17.1		2.0		17.7		13.9	18.0	
LOS		B		B		A		B		B	B	
Approach Delay		16.5				10.6		17.7			18.0	
Approach LOS		B				B		B			B	
Queue Length 50th (m)		23.7		3.7		0.0		22.2		0.6	38.1	
Queue Length 95th (m)		42.7		9.6		2.2		31.8		m1.3	47.2	
Internal Link Dist (m)		54.5				21.0		120.5			136.3	
Turn Bay Length (m)										20.0		
Base Capacity (vph)		644		431		591		1455		334	1478	
Starvation Cap Reductn		0		0		0		0		0	0	
Spillback Cap Reductn		0		0		0		0		0	0	
Storage Cap Reductn		0		0		0		0		0	0	
Reduced v/c Ratio		0.38		0.08		0.04		0.25		0.02	0.34	

<b>Intersection Summary</b>	
Cycle Length:	100
Actuated Cycle Length:	100
Offset:	0 (0%), Referenced to phase 2:NBT and 6:SBTL, Start of Green
Natural Cycle:	65
Control Type:	Actuated-Coordinated

Lanes, Volumes, Timings  
5: Elgin & Nepean/City Hall

2027 Future Background  
PM Peak Hour

Lane Group	Ø3	Ø7
Lane Configurations		
Traffic Volume (vph)		
Future Volume (vph)		
Satd. Flow (prot)		
Flt Permitted		
Satd. Flow (perm)		
Satd. Flow (RTOR)		
Lane Group Flow (vph)		
Turn Type		
Protected Phases	3	7
Permitted Phases		
Detector Phase		
Switch Phase		
Minimum Initial (s)	1.0	1.0
Minimum Split (s)	5.0	5.0
Total Split (s)	5.0	5.0
Total Split (%)	5%	5%
Yellow Time (s)	2.0	2.0
All-Red Time (s)	0.0	0.0
Lost Time Adjust (s)		
Total Lost Time (s)		
Lead/Lag	Lead	Lead
Lead-Lag Optimize?	Yes	Yes
Recall Mode	None	None
Act Effct Green (s)		
Actuated g/C Ratio		
v/c Ratio		
Control Delay		
Queue Delay		
Total Delay		
LOS		
Approach Delay		
Approach LOS		
Queue Length 50th (m)		
Queue Length 95th (m)		
Internal Link Dist (m)		
Turn Bay Length (m)		
Base Capacity (vph)		
Starvation Cap Reductn		
Spillback Cap Reductn		
Storage Cap Reductn		
Reduced v/c Ratio		
Intersection Summary		

Lanes, Volumes, Timings  
5: Elgin & Nepean/City Hall

2027 Future Background  
PM Peak Hour

Maximum v/c Ratio: 0.38	Intersection LOS: B
Intersection Signal Delay: 17.2	ICU Level of Service C
Intersection Capacity Utilization 66.6%	
Analysis Period (min) 15	
m Volume for 95th percentile queue is metered by upstream signal.	

Splits and Phases: 5: Elgin & Nepean/City Hall





# Appendix H

Synchro Intersection Worksheets – 2032 Future Background Conditions

Lanes, Volumes, Timings  
1: O'Connor & Laurier

2032 Future Background  
AM Peak Hour

Lane Group	EBL	EBT	EBR	WBL	WBT	WBR	NBL	NBT	NBR	SBL	SBT	SBR
Lane Configurations		↔		↔	↔						↕↕↕	
Traffic Volume (vph)	0	215	122	133	334	0	0	0	0	85	451	67
Future Volume (vph)	0	215	122	133	334	0	0	0	0	85	451	67
Satd. Flow (prot)	0	1430	0	1642	1712	0	0	0	0	0	4174	0
Flt Permitted				0.382							0.993	
Satd. Flow (perm)	0	1430	0	660	1712	0	0	0	0	0	3784	0
Satd. Flow (RTOR)												
Lane Group Flow (vph)	0	337	0	133	334	0	0	0	0	0	603	0
Turn Type		NA		pm+pt	NA					Perm	NA	
Protected Phases		2		9	6						4	
Permitted Phases				6						4		
Detector Phase		2		9	6					4	4	
Switch Phase												
Minimum Initial (s)		10.0		5.0	10.0					10.0	10.0	
Minimum Split (s)		23.9		10.8	21.9					22.5	22.5	
Total Split (s)		29.0		11.0	45.0					25.0	25.0	
Total Split (%)		38.7%		14.7%	60.0%					33.3%	33.3%	
Yellow Time (s)		3.3		3.3	3.3					3.3	3.3	
All-Red Time (s)		2.6		2.5	2.6					2.6	2.6	
Lost Time Adjust (s)		0.0		0.0	0.0					0.0	0.0	
Total Lost Time (s)		5.9		5.8	5.9					5.9	5.9	
Lead/Lag				Lead						Lag	Lag	
Lead-Lag Optimize?				Yes						Yes	Yes	
Recall Mode		C-Max		Max	C-Max					Max	Max	
Act Effct Green (s)		28.1		39.2	39.1					24.1	24.1	
Actuated g/C Ratio		0.37		0.52	0.52					0.32	0.32	
v/c Ratio		0.63		0.32	0.37					0.50	0.50	
Control Delay		25.6		7.1	6.7					22.3	22.3	
Queue Delay		0.0		0.0	0.0					0.0	0.0	
Total Delay		25.6		7.1	6.7					22.3	22.3	
LOS		C		A	A					C	C	
Approach Delay		25.6			6.8					22.3	22.3	
Approach LOS		C			A					C	C	
Queue Length 50th (m)		38.1		5.2	13.3					24.9	24.9	
Queue Length 95th (m)		64.6		m9.3	19.8					34.9	34.9	
Internal Link Dist (m)		71.8			158.7			39.2		62.3	62.3	
Turn Bay Length (m)												
Base Capacity (vph)		535		413	892					1215	1215	
Starvation Cap Reductn		0		0	0					0	0	
Spillback Cap Reductn		0		0	0					0	0	
Storage Cap Reductn		0		0	0					0	0	
Reduced v/c Ratio		0.63		0.32	0.37					0.50	0.50	

Intersection Summary	
Cycle Length: 75	
Actuated Cycle Length: 75	
Offset: 63 (84%), Referenced to phase 2:EBT and 6:WBTL, Start of Green	
Natural Cycle: 70	
Control Type: Actuated-Coordinated	

Lanes, Volumes, Timings  
1: O'Connor & Laurier

2032 Future Background  
AM Peak Hour

Lane Group	Ø1	Ø3
Lane Configurations		
Traffic Volume (vph)		
Future Volume (vph)		
Satd. Flow (prot)		
Flt Permitted		
Satd. Flow (perm)		
Satd. Flow (RTOR)		
Lane Group Flow (vph)		
Turn Type		
Protected Phases	1	3
Permitted Phases		
Detector Phase		
Switch Phase		
Minimum Initial (s)	1.0	1.0
Minimum Split (s)	5.0	5.0
Total Split (s)	5.0	5.0
Total Split (%)	7%	7%
Yellow Time (s)	2.0	2.0
All-Red Time (s)	0.0	0.0
Lost Time Adjust (s)		
Total Lost Time (s)		
Lead/Lag	Lag	Lead
Lead-Lag Optimize?	Yes	Yes
Recall Mode	None	None
Act Effct Green (s)		
Actuated g/C Ratio		
v/c Ratio		
Control Delay		
Queue Delay		
Total Delay		
LOS		
Approach Delay		
Approach LOS		
Queue Length 50th (m)		
Queue Length 95th (m)		
Internal Link Dist (m)		
Turn Bay Length (m)		
Base Capacity (vph)		
Starvation Cap Reductn		
Spillback Cap Reductn		
Storage Cap Reductn		
Reduced v/c Ratio		

Intersection Summary	
Cycle Length: 75	
Actuated Cycle Length: 75	
Offset: 63 (84%), Referenced to phase 2:EBT and 6:WBTL, Start of Green	
Natural Cycle: 70	
Control Type: Actuated-Coordinated	

Lanes, Volumes, Timings  
1: O'Connor & Laurier

2032 Future Background  
AM Peak Hour

Maximum v/c Ratio: 0.63	Intersection LOS: B
Intersection Signal Delay: 17.9	ICU Level of Service B
Intersection Capacity Utilization 61.2%	
Analysis Period (min) 15	

m Volume for 95th percentile queue is metered by upstream signal.

Splits and Phases: 1: O'Connor & Laurier



Lanes, Volumes, Timings  
2: Metcalfe & Laurier

2032 Future Background  
AM Peak Hour

Lane Group	EBL	EBT	EBR	WBL	WBT	WBR	NBL	NBT	NBR	SBL	SBT	SBR
Lane Configurations		↕			↕			↕				
Traffic Volume (vph)	22	288	0	0	391	256	96	704	74	0	0	0
Future Volume (vph)	22	288	0	0	391	256	96	704	74	0	0	0
Satd. Flow (prot)	0	1734	0	0	2511	0	0	4356	0	0	0	0
Flt Permitted		0.938						0.995				
Satd. Flow (perm)	0	1617	0	0	2511	0	0	4161	0	0	0	0
Satd. Flow (RTOR)												
Lane Group Flow (vph)	0	310	0	0	647	0	0	874	0	0	0	0
Turn Type	Perm	NA			NA		Perm	NA				
Protected Phases		2			6			4				
Permitted Phases	2							4				
Detector Phase	2	2			6			4	4			
Switch Phase												
Minimum Initial (s)	10.0	10.0			10.0			10.0	10.0			
Minimum Split (s)	37.0	37.0			37.0			33.0	33.0			
Total Split (s)	37.0	37.0			37.0			33.0	33.0			
Total Split (%)	49.3%	49.3%			49.3%			44.0%	44.0%			
Yellow Time (s)	3.3	3.3			3.3			3.3	3.3			
All-Red Time (s)	2.4	2.4			2.4			2.2	2.2			
Lost Time Adjust (s)		0.0			0.0			0.0	0.0			
Total Lost Time (s)		5.7			5.7			5.5	5.5			
Lead/Lag	Lag	Lag			Lag							
Lead-Lag Optimize?	Yes	Yes			Yes							
Recall Mode	C-Max	C-Max			C-Max			Max	Max			
Act Effct Green (s)		36.3			36.3				27.5			
Actuated g/C Ratio		0.48			0.48				0.37			
v/c Ratio		0.40			0.53				0.57			
Control Delay		19.1			15.5				15.3			
Queue Delay		0.0			0.0				0.4			
Total Delay		19.1			15.5				15.7			
LOS		B			B				B			
Approach Delay		19.1			15.5				15.7			
Approach LOS		B			B				B			
Queue Length 50th (m)		31.3			31.6				36.9			
Queue Length 95th (m)		56.3			46.1				49.0			
Internal Link Dist (m)		158.7			172.2				51.7		65.1	
Turn Bay Length (m)												
Base Capacity (vph)		782			1215				1525			
Starvation Cap Reductn		0			0				239			
Spillback Cap Reductn		0			0				0			
Storage Cap Reductn		0			0				0			
Reduced v/c Ratio		0.40			0.53				0.68			

Intersection Summary	
Cycle Length:	75
Actuated Cycle Length:	75
Offset:	48 (64%), Referenced to phase 2:EBTL and 6:WBT, Start of Green
Natural Cycle:	75
Control Type:	Actuated-Coordinated

Lane Group	Ø1	Ø5
Lane Configurations		
Traffic Volume (vph)		
Future Volume (vph)		
Satd. Flow (prot)		
Flt Permitted		
Satd. Flow (perm)		
Satd. Flow (RTOR)		
Lane Group Flow (vph)		
Turn Type		
Protected Phases	1	5
Permitted Phases		
Detector Phase		
Switch Phase		
Minimum Initial (s)	1.0	1.0
Minimum Split (s)	5.0	5.0
Total Split (s)	5.0	5.0
Total Split (%)	7%	7%
Yellow Time (s)	2.0	2.0
All-Red Time (s)	0.0	0.0
Lost Time Adjust (s)		
Total Lost Time (s)		
Lead/Lag	Lead	Lead
Lead-Lag Optimize?	Yes	Yes
Recall Mode	None	None
Act Effct Green (s)		
Actuated g/C Ratio		
v/c Ratio		
Control Delay		
Queue Delay		
Total Delay		
LOS		
Approach Delay		
Approach LOS		
Queue Length 50th (m)		
Queue Length 95th (m)		
Internal Link Dist (m)		
Turn Bay Length (m)		
Base Capacity (vph)		
Starvation Cap Reductn		
Spillback Cap Reductn		
Storage Cap Reductn		
Reduced v/c Ratio		
Intersection Summary		

Maximum v/c Ratio: 0.57	
Intersection Signal Delay: 16.2	Intersection LOS: B
Intersection Capacity Utilization 65.8%	ICU Level of Service C
Analysis Period (min) 15	



Lanes, Volumes, Timings  
3: Elgin & Laurier/City Hall

2032 Future Background  
AM Peak Hour

Lane Group	EBL	EBT	EBR	WBL	WBT	WBR	NBL	NBT	NBR	SBL	SBT	SBR
Lane Configurations		↑↑		↑	↑	↑		↑↑	↑	↑↑	↑↑	
Traffic Volume (vph)	0	285	57	209	497	538	0	213	59	361	376	170
Future Volume (vph)	0	285	57	209	497	538	0	213	59	361	376	170
Satd. Flow (prot)	0	3043	0	1658	1745	1483	0	3316	1483	3154	2434	0
Flt Permitted				0.532						0.950		
Satd. Flow (perm)	0	3043	0	771	1745	920	0	3316	680	1878	2434	0
Satd. Flow (RTOR)									149		91	
Lane Group Flow (vph)	0	342	0	209	497	538	0	213	59	361	546	0
Turn Type		NA		custom	NA	custom		NA	pm+ov	Prot	NA	
Protected Phases		2		9	5	6		3		9	3	8
Permitted Phases				6		6				4		
Detector Phase		2		9	5	6		3		4	9	3
Switch Phase												
Minimum Initial (s)		5.0		5.0		10.0		10.0	5.0	10.0	10.0	
Minimum Split (s)		30.0		12.0		20.7		28.2	12.0	20.7	28.2	
Total Split (s)		31.0		15.0		20.8		28.2	15.0	20.8	49.0	
Total Split (%)		31.0%		15.0%		20.8%		28.2%	15.0%	20.8%	49.0%	
Yellow Time (s)		3.3		3.3		3.3		3.3	3.3	3.3	3.3	
All-Red Time (s)		3.7		3.7		4.4		2.9	3.7	4.4	2.9	
Lost Time Adjust (s)		0.0		0.0		0.0		0.0	0.0	0.0	0.0	
Total Lost Time (s)		7.0		7.0		7.7		6.2	7.0	7.7	6.2	
Lead/Lag				Lead		Lead		Lag	Lead		Lead	
Lead-Lag Optimize?				Yes		Yes		Yes	Yes		Yes	
Recall Mode		C-Max		Max		None		Max	Max		None	Max
Act Effct Green (s)		29.0		37.0		49.0		22.0	29.2		13.1	42.8
Actuated g/C Ratio		0.29		0.37		0.49		0.22	0.29		0.13	0.43
v/c Ratio		0.39		0.59		0.58		0.29	0.16		0.87	0.50
Control Delay		30.0		27.2		21.6		33.8	0.9		65.4	18.9
Queue Delay		0.0		0.0		0.0		0.0	0.0		0.0	0.0
Total Delay		30.0		27.2		21.6		33.8	0.9		65.4	18.9
LOS		C		C		C		C	A		E	B
Approach Delay		30.0				28.6		26.7				37.4
Approach LOS		C				C		C				D
Queue Length 50th (m)		27.8		25.3		66.1		39.9		18.2	0.0	35.8
Queue Length 95th (m)		40.4		41.4		97.3		#89.7		28.4	0.0	#60.1
Internal Link Dist (m)		172.2				106.8				136.3		
Turn Bay Length (m)										90.0		85.0
Base Capacity (vph)		882		356		855		594		729	368	413
Starvation Cap Reductn		0		0		0		0		0	0	0
Spillback Cap Reductn		0		0		0		0		0	0	0
Storage Cap Reductn		0		0		0		0		0	0	0
Reduced v/c Ratio		0.39		0.59		0.58		0.91		0.29	0.16	0.87

Intersection Summary	
Cycle Length: 100	
Actuated Cycle Length: 100	
Offset: 64 (64%), Referenced to phase 2:EBT and 6:WBTL, Start of Green	
Natural Cycle: 100	
Control Type: Actuated-Coordinated	

Lanes, Volumes, Timings  
3: Elgin & Laurier/City Hall

2032 Future Background  
AM Peak Hour

Lane Group	Ø1	Ø5	Ø6	Ø13
Lane Configurations				
Traffic Volume (vph)				
Future Volume (vph)				
Satd. Flow (prot)				
Flt Permitted				
Satd. Flow (perm)				
Satd. Flow (RTOR)				
Lane Group Flow (vph)				
Turn Type				
Protected Phases	1	5	6	13
Permitted Phases				
Detector Phase				
Switch Phase				
Minimum Initial (s)	1.0	1.0	5.0	1.0
Minimum Split (s)	5.0	7.0	25.0	5.0
Total Split (s)	5.0	10.0	36.0	5.0
Total Split (%)	5%	10%	36%	5%
Yellow Time (s)	2.0	2.0	2.0	2.0
All-Red Time (s)	0.0	0.0	0.0	0.0
Lost Time Adjust (s)				
Total Lost Time (s)				
Lead/Lag	Lag	Lag		Lead
Lead-Lag Optimize?	Yes	Yes		Yes
Recall Mode	None	None	C-Max	None
Act Effct Green (s)				
Actuated g/C Ratio				
v/c Ratio				
Control Delay				
Queue Delay				
Total Delay				
LOS				
Approach Delay				
Approach LOS				
Queue Length 50th (m)				
Queue Length 95th (m)				
Internal Link Dist (m)				
Turn Bay Length (m)				
Base Capacity (vph)				
Starvation Cap Reductn				
Spillback Cap Reductn				
Storage Cap Reductn				
Reduced v/c Ratio				

Intersection Summary	
Cycle Length: 100	
Actuated Cycle Length: 100	
Offset: 64 (64%), Referenced to phase 2:EBT and 6:WBTL, Start of Green	
Natural Cycle: 100	
Control Type: Actuated-Coordinated	

Lanes, Volumes, Timings  
3: Elgin & Laurier/City Hall

2032 Future Background  
AM Peak Hour

Maximum v/c Ratio: 0.91	Intersection LOS: C
Intersection Signal Delay: 31.5	ICU Level of Service E
Intersection Capacity Utilization 83.8%	
Analysis Period (min) 15	
# 95th percentile volume exceeds capacity, queue may be longer.	
Queue shown is maximum after two cycles.	

Splits and Phases: 3: Elgin & Laurier/City Hall

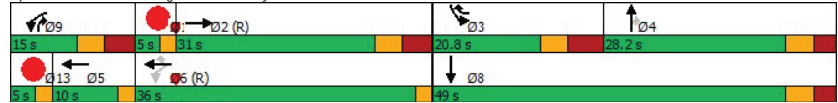

Lanes, Volumes, Timings  
4: Metcalfe & Gloucester

2032 Future Background  
AM Peak Hour

Lane Group	EBL	EBT	EBR	WBL	WBT	WBR	NBL	NBT	NBR	SBL	SBT	SBR
Lane Configurations					↕↕			↕↕↕				
Traffic Volume (vph)	0	0	0	0	164	74	247	810	0	0	0	0
Future Volume (vph)	0	0	0	0	164	74	247	810	0	0	0	0
Satd. Flow (prot)	0	0	0	0	2845	0	0	4696	0	0	0	0
Flt Permitted								0.988				
Satd. Flow (perm)	0	0	0	0	2845	0	0	4330	0	0	0	0
Satd. Flow (RTOR)					26			89				
Lane Group Flow (vph)	0	0	0	0	238	0	0	1057	0	0	0	0
Turn Type					NA			Perm	NA			
Protected Phases					4			2				
Permitted Phases								2				
Detector Phase					4			2	2			
Switch Phase												
Minimum Initial (s)					10.0			10.0	10.0			
Minimum Split (s)					23.1			35.0	35.0			
Total Split (s)					25.0			50.0	50.0			
Total Split (%)					33.3%			66.7%	66.7%			
Yellow Time (s)					3.3			3.3	3.3			
All-Red Time (s)					1.8			1.7	1.7			
Lost Time Adjust (s)					0.0			0.0	0.0			
Total Lost Time (s)					5.1			5.0	5.0			
Lead/Lag												
Lead-Lag Optimize?												
Recall Mode					Max			C-Max	C-Max			
Act Effct Green (s)					19.9			35.0	45.0			
Actuated g/C Ratio					0.27			0.60	0.60			
v/c Ratio					0.31			0.40	0.40			
Control Delay					20.8			7.7	7.7			
Queue Delay					0.0			0.0	0.0			
Total Delay					20.8			7.7	7.7			
LOS					C			A	A			
Approach Delay					20.8			7.7	7.7			
Approach LOS					C			A	A			
Queue Length 50th (m)					12.4			23.2	23.2			
Queue Length 95th (m)					21.5			30.9	30.9			
Internal Link Dist (m)						34.9		48.3	35.0			51.7
Turn Bay Length (m)												
Base Capacity (vph)					773			2633	2633			
Starvation Cap Reductn					0			0	0			
Spillback Cap Reductn					0			144	144			
Storage Cap Reductn					0			0	0			
Reduced v/c Ratio					0.31			0.42	0.42			
<b>Intersection Summary</b>												
Cycle Length: 75												
Actuated Cycle Length: 75												
Offset: 73 (97%), Referenced to phase 2:NBTL, Start of Green												
Natural Cycle: 60												
Control Type: Actuated-Coordinated												

Lanes, Volumes, Timings  
4: Metcalfe & Gloucester

2032 Future Background  
AM Peak Hour

Maximum v/c Ratio: 0.40	Intersection LOS: B
Intersection Signal Delay: 10.1	ICU Level of Service A
Intersection Capacity Utilization 44.1%	
Analysis Period (min) 15	

Splits and Phases: 4: Metcalfe & Gloucester



Lanes, Volumes, Timings  
5: Elgin & Nepean

2032 Future Background  
AM Peak Hour

Lane Group	EBL	EBT	EBR	WBL	WBT	WBR	NBL	NBT	NBR	SBL	SBT	SBR
Lane Configurations		↔		↔		↔		↔		↔	↔	↔
Traffic Volume (vph)	31	7	31	1	0	9	0	281	43	17	336	0
Future Volume (vph)	31	7	31	1	0	9	0	281	43	17	336	0
Satd. Flow (prot)	0	1506	0	1658	0	1483	0	3079	0	1658	3252	0
Flt Permitted		0.978		0.712						0.556		
Satd. Flow (perm)	0	1427	0	1188	0	1294	0	3079	0	850	3252	0
Satd. Flow (RTOR)		31				53		32				
Lane Group Flow (vph)	0	69	0	1	0	9	0	324	0	17	336	0
Turn Type	Perm	NA	Perm	Perm	NA	Perm	NA	Perm	NA	Perm	NA	
Protected Phases		4						2				6
Permitted Phases	4			8		8				6		
Detector Phase	4	4		8		8		2		6		6
Switch Phase												
Minimum Initial (s)	10.0	10.0		10.0		10.0		10.0		10.0		10.0
Minimum Split (s)	25.1	25.1		25.1		25.1		31.4		31.4		31.4
Total Split (s)	27.0	27.0		27.0		27.0		58.0		58.0		58.0
Total Split (%)	30.0%	30.0%		30.0%		30.0%		64.4%		64.4%		64.4%
Yellow Time (s)	3.3	3.3		3.3		3.3		3.3		3.3		3.3
All-Red Time (s)	2.8	2.8		2.8		2.8		2.1		2.1		2.1
Lost Time Adjust (s)		0.0		0.0		0.0		0.0		0.0		0.0
Total Lost Time (s)		6.1		6.1		6.1		5.4		5.4		5.4
Lead/Lag	Lag	Lag		Lag		Lag						
Lead-Lag Optimize?	Yes	Yes		Yes		Yes						
Recall Mode	Max	Max		Max		Max		C-Max		C-Max		C-Max
Act Effct Green (s)		25.9		25.9		25.9		52.6		52.6		52.6
Actuated g/C Ratio		0.29		0.29		0.29		0.58		0.58		0.58
v/c Ratio		0.16		0.00		0.02		0.18		0.03		0.18
Control Delay		16.1		23.0		0.1		8.1		8.2		9.0
Queue Delay		0.0		0.0		0.0		0.0		0.0		0.0
Total Delay		16.1		23.0		0.1		8.1		8.2		9.0
LOS		B		C		A		A		A		A
Approach Delay		16.1				2.4		8.1				8.9
Approach LOS		B				A		A				A
Queue Length 50th (m)		4.8		0.1		0.0		11.2		1.2		13.1
Queue Length 95th (m)		14.5		1.3		0.0		17.3		3.8		19.3
Internal Link Dist (m)		54.5				21.0		120.5				136.3
Turn Bay Length (m)										20.0		
Base Capacity (vph)		432		341		410		1812		496		1900
Starvation Cap Reductn		0		0		0		0		0		0
Spillback Cap Reductn		0		0		0		0		0		0
Storage Cap Reductn		0		0		0		0		0		0
Reduced v/c Ratio		0.16		0.00		0.02		0.18		0.03		0.18

Intersection Summary

Cycle Length: 90
Actuated Cycle Length: 90
Offset: 0 (0%), Referenced to phase 2:NBT and 6:SBTL, Start of Green
Natural Cycle: 65
Control Type: Actuated-Coordinated

Lanes, Volumes, Timings  
5: Elgin & Nepean

2032 Future Background  
AM Peak Hour

Lane Group	Ø3	Ø7
Lane Configurations		
Traffic Volume (vph)		
Future Volume (vph)		
Satd. Flow (prot)		
Flt Permitted		
Satd. Flow (perm)		
Satd. Flow (RTOR)		
Lane Group Flow (vph)		
Turn Type		
Protected Phases	3	7
Permitted Phases		
Detector Phase		
Switch Phase		
Minimum Initial (s)	1.0	1.0
Minimum Split (s)	5.0	5.0
Total Split (s)	5.0	5.0
Total Split (%)	6%	6%
Yellow Time (s)	2.0	2.0
All-Red Time (s)	0.0	0.0
Lost Time Adjust (s)		
Total Lost Time (s)		
Lead/Lag	Lead	Lead
Lead-Lag Optimize?	Yes	Yes
Recall Mode	None	None
Act Effct Green (s)		
Actuated g/C Ratio		
v/c Ratio		
Control Delay		
Queue Delay		
Total Delay		
LOS		
Approach Delay		
Approach LOS		
Queue Length 50th (m)		
Queue Length 95th (m)		
Internal Link Dist (m)		
Turn Bay Length (m)		
Base Capacity (vph)		
Starvation Cap Reductn		
Spillback Cap Reductn		
Storage Cap Reductn		
Reduced v/c Ratio		
Intersection Summary		

Lanes, Volumes, Timings  
5: Elgin & Nepean

2032 Future Background  
AM Peak Hour

Maximum v/c Ratio: 0.18	Intersection LOS: A
Intersection Signal Delay: 9.1	ICU Level of Service C
Intersection Capacity Utilization 66.3%	
Analysis Period (min) 15	

Splits and Phases: 5: Elgin & Nepean

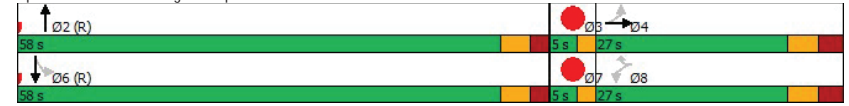



Lanes, Volumes, Timings  
1: O'Connor & Laurier

2032 Future Background  
PM Peak Hour

Lane Group	EBL	EBT	EBR	WBL	WBT	WBR	NBL	NBT	NBR	SBL	SBT	SBR
Lane Configurations		↔	↔	↔	↔	↔	↔	↔	↔	↔	↔	↔
Traffic Volume (vph)	0	204	95	179	273	0	0	0	0	51	544	44
Future Volume (vph)	0	204	95	179	273	0	0	0	0	51	544	44
Satd. Flow (prot)	0	1472	0	1642	1745	0	0	0	0	0	4480	0
Flt Permitted				0.386							0.996	
Satd. Flow (perm)	0	1472	0	667	1745	0	0	0	0	0	4249	0
Satd. Flow (RTOR)												
Lane Group Flow (vph)	0	333	0	199	303	0	0	0	0	0	710	0
Turn Type		NA		pm+pt	NA					Perm	NA	
Protected Phases		2		9	6						4	
Permitted Phases				6						4		
Detector Phase		2		9	6					4	4	
Switch Phase												
Minimum Initial (s)		10.0		5.0	10.0					10.0	10.0	
Minimum Split (s)		23.9		10.8	21.9					22.5	22.5	
Total Split (s)		29.0		11.0	45.0					25.0	25.0	
Total Split (%)		38.7%		14.7%	60.0%					33.3%	33.3%	
Yellow Time (s)		3.3		3.3	3.3					3.3	3.3	
All-Red Time (s)		2.6		2.5	2.6					2.6	2.6	
Lost Time Adjust (s)		0.0		0.0	0.0					0.0	0.0	
Total Lost Time (s)		5.9		5.8	5.9					5.9	5.9	
Lead/Lag				Lead						Lag	Lag	
Lead-Lag Optimize?				Yes						Yes	Yes	
Recall Mode		C-Max		Max	C-Max					Max	Max	
Act Effct Green (s)		28.1		39.2	39.1					24.1	24.1	
Actuated g/C Ratio		0.37		0.52	0.52					0.32	0.32	
v/c Ratio		0.60		0.48	0.33					0.52	0.52	
Control Delay		24.6		22.1	16.2					22.4	22.4	
Queue Delay		0.0		0.0	0.0					0.0	0.0	
Total Delay		24.6		22.1	16.2					22.4	22.4	
LOS		C		C	B					C	C	
Approach Delay		24.6			18.6					22.4	22.4	
Approach LOS		C			B					C	C	
Queue Length 50th (m)		37.2		18.6	25.8					29.6	29.6	
Queue Length 95th (m)		62.9		37.2	46.7					40.4	40.4	
Internal Link Dist (m)		71.8			158.7			39.2		62.3	62.3	
Turn Bay Length (m)												
Base Capacity (vph)		551		416	909					1365	1365	
Starvation Cap Reductn		0		0	0					0	0	
Spillback Cap Reductn		0		0	0					0	0	
Storage Cap Reductn		0		0	0					0	0	
Reduced v/c Ratio		0.60		0.48	0.33					0.52	0.52	

Intersection Summary	
Cycle Length: 75	
Actuated Cycle Length: 75	
Offset: 22 (29%), Referenced to phase 2:EBT and 6:WBTL, Start of Green	
Natural Cycle: 70	
Control Type: Actuated-Coordinated	

Lanes, Volumes, Timings  
1: O'Connor & Laurier

2032 Future Background  
PM Peak Hour

Lane Group	Ø1	Ø3
Lane Configurations		
Traffic Volume (vph)		
Future Volume (vph)		
Satd. Flow (prot)		
Flt Permitted		
Satd. Flow (perm)		
Satd. Flow (RTOR)		
Lane Group Flow (vph)		
Turn Type		
Protected Phases	1	3
Permitted Phases		
Detector Phase		
Switch Phase		
Minimum Initial (s)	1.0	1.0
Minimum Split (s)	5.0	5.0
Total Split (s)	5.0	5.0
Total Split (%)	7%	7%
Yellow Time (s)	2.0	2.0
All-Red Time (s)	0.0	0.0
Lost Time Adjust (s)		
Total Lost Time (s)		
Lead/Lag	Lag	Lead
Lead-Lag Optimize?	Yes	Yes
Recall Mode	None	None
Act Effct Green (s)		
Actuated g/C Ratio		
v/c Ratio		
Control Delay		
Queue Delay		
Total Delay		
LOS		
Approach Delay		
Approach LOS		
Queue Length 50th (m)		
Queue Length 95th (m)		
Internal Link Dist (m)		
Turn Bay Length (m)		
Base Capacity (vph)		
Starvation Cap Reductn		
Spillback Cap Reductn		
Storage Cap Reductn		
Reduced v/c Ratio		

Intersection Summary	
Cycle Length: 75	
Actuated Cycle Length: 75	
Offset: 22 (29%), Referenced to phase 2:EBT and 6:WBTL, Start of Green	
Natural Cycle: 70	
Control Type: Actuated-Coordinated	

Lanes, Volumes, Timings  
1: O'Connor & Laurier

2032 Future Background  
PM Peak Hour

Maximum v/c Ratio: 0.60	Intersection LOS: C
Intersection Signal Delay: 21.6	ICU Level of Service B
Intersection Capacity Utilization 61.4%	
Analysis Period (min) 15	

Splits and Phases: 1: O'Connor & Laurier

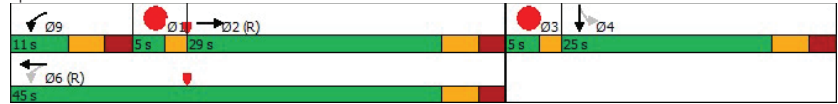

Lanes, Volumes, Timings  
2: Metcalfe & Laurier

2032 Future Background  
PM Peak Hour

Lane Group	EBL	EBT	EBR	WBL	WBT	WBR	NBL	NBT	NBR	SBL	SBT	SBR
Lane Configurations		↕			↕			↕↕↕				
Traffic Volume (vph)	10	245	0	0	392	166	33	415	126	0	0	0
Future Volume (vph)	10	245	0	0	392	166	33	415	126	0	0	0
Satd. Flow (prot)	0	1742	0	0	2811	0	0	3782	0	0	0	0
Flt Permitted		0.974						0.997				
Satd. Flow (perm)	0	1691	0	0	2811	0	0	3701	0	0	0	0
Satd. Flow (RTOR)												
Lane Group Flow (vph)	0	283	0	0	620	0	0	638	0	0	0	0
Turn Type	Perm	NA			NA		Perm	NA				
Protected Phases		2			6			4				
Permitted Phases	2						4					
Detector Phase	2	2			6		4	4				
Switch Phase												
Minimum Initial (s)	10.0	10.0			10.0		10.0	10.0				
Minimum Split (s)	37.0	37.0			37.0		19.5	19.5				
Total Split (s)	40.0	40.0			40.0		30.0	30.0				
Total Split (%)	53.3%	53.3%			53.3%		40.0%	40.0%				
Yellow Time (s)	3.3	3.3			3.3		3.3	3.3				
All-Red Time (s)	2.4	2.4			2.4		2.2	2.2				
Lost Time Adjust (s)		0.0			0.0			0.0				
Total Lost Time (s)		5.7			5.7			5.5				
Lead/Lag	Lag	Lag			Lag							
Lead-Lag Optimize?	Yes	Yes			Yes							
Recall Mode	C-Max	C-Max			C-Max		Max	Max				
Act Effct Green (s)		39.3			39.3			24.5				
Actuated g/C Ratio		0.52			0.52			0.33				
v/c Ratio		0.32			0.42			0.53				
Control Delay		6.6			12.0			17.7				
Queue Delay		0.0			0.0			0.3				
Total Delay		6.6			12.0			18.1				
LOS		A			B			B				
Approach Delay		6.6			12.0			18.1				
Approach LOS		A			B			B				
Queue Length 50th (m)		8.9			26.2			16.9				
Queue Length 95th (m)		13.5			37.8			21.6				
Internal Link Dist (m)		158.7			172.2			51.7			65.1	
Turn Bay Length (m)												
Base Capacity (vph)		886			1472			1208				
Starvation Cap Reductn		0			0			176				
Spillback Cap Reductn		0			0			0				
Storage Cap Reductn		0			0			0				
Reduced v/c Ratio		0.32			0.42			0.62				

Intersection Summary

Cycle Length: 75
Actuated Cycle Length: 75
Offset: 30 (40%), Referenced to phase 2:EBTL and 6:WBT, Start of Green
Natural Cycle: 65
Control Type: Actuated-Coordinated

Lane Group	Ø1	Ø5
Lane Configurations		
Traffic Volume (vph)		
Future Volume (vph)		
Satd. Flow (prot)		
Flt Permitted		
Satd. Flow (perm)		
Satd. Flow (RTOR)		
Lane Group Flow (vph)		
Turn Type		
Protected Phases	1	5
Permitted Phases		
Detector Phase		
Switch Phase		
Minimum Initial (s)	1.0	1.0
Minimum Split (s)	5.0	5.0
Total Split (s)	5.0	5.0
Total Split (%)	7%	7%
Yellow Time (s)	2.0	2.0
All-Red Time (s)	0.0	0.0
Lost Time Adjust (s)		
Total Lost Time (s)		
Lead/Lag	Lead	Lead
Lead-Lag Optimize?	Yes	Yes
Recall Mode	None	None
Act Effct Green (s)		
Actuated g/C Ratio		
v/c Ratio		
Control Delay		
Queue Delay		
Total Delay		
LOS		
Approach Delay		
Approach LOS		
Queue Length 50th (m)		
Queue Length 95th (m)		
Internal Link Dist (m)		
Turn Bay Length (m)		
Base Capacity (vph)		
Starvation Cap Reductn		
Spillback Cap Reductn		
Storage Cap Reductn		
Reduced v/c Ratio		
Intersection Summary		

Maximum v/c Ratio: 0.53	
Intersection Signal Delay: 13.5	Intersection LOS: B
Intersection Capacity Utilization 48.3%	ICU Level of Service A
Analysis Period (min) 15	

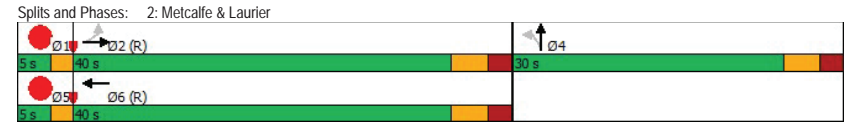

Lanes, Volumes, Timings  
3: Elgin & Laurier

2032 Future Background  
PM Peak Hour

Lane Group	EBL	EBT	EBR	WBL	WBT	WBR	NBL	NBT	NBR	SBL	SBT	SBR
Lane Configurations		↕		↕	↕	↕		↕	↕	↕	↕	↕
Traffic Volume (vph)	0	362	29	117	429	413	0	280	161	382	363	108
Future Volume (vph)	0	362	29	117	429	413	0	280	161	382	363	108
Satd. Flow (prot)	0	3205	0	1642	1745	1483	0	3316	1483	3154	2647	0
Fit Permitted				0.465						0.950		
Satd. Flow (perm)	0	3205	0	696	1745	976	0	3316	680	2247	2647	0
Satd. Flow (RTOR)					213				149		50	
Lane Group Flow (vph)	0	434	0	130	477	459	0	311	179	424	523	0
Turn Type		NA		custom	NA	custom		NA	pm+ov	Prot	NA	
Protected Phases		2		9	5	6		3	4	9	3	8
Permitted Phases				6		6			4			
Detector Phase		2		9	5	6		3	4	9	3	8
Switch Phase												
Minimum Initial (s)		5.0		5.0		10.0		10.0	5.0	10.0		10.0
Minimum Split (s)		30.0		12.0		20.7		28.2	12.0	20.7		28.2
Total Split (s)		31.0		14.0		21.8		28.2	14.0	21.8		50.0
Total Split (%)		31.0%		14.0%		21.8%		28.2%	14.0%	21.8%		50.0%
Yellow Time (s)		3.3		3.3		3.3		3.3	3.3	3.3		3.3
All-Red Time (s)		3.7		3.7		4.4		2.9	3.7	4.4		2.9
Lost Time Adjust (s)		0.0		0.0		0.0		0.0	0.0	0.0		0.0
Total Lost Time (s)		7.0		7.0		7.7		6.2	7.0	7.7		6.2
Lead/Lag				Lead		Lead		Lag	Lead		Lead	
Lead-Lag Optimize?				Yes		Yes		Yes	Yes		Yes	
Recall Mode		C-Max		None		None		Max	None	None		Max
Act Effct Green (s)		29.0		35.0		48.0		22.0	28.2	14.1		43.8
Actuated g/C Ratio		0.29		0.35		0.48		0.22	0.28	0.14		0.44
v/c Ratio		0.47		0.42		0.57		0.43	0.51	0.95		0.44
Control Delay		31.2		23.1		22.0		25.1	8.4	76.6		19.0
Queue Delay		0.0		0.0		0.0		0.0	0.0	0.0		0.0
Total Delay		31.2		23.1		22.0		25.1	8.4	76.6		19.0
LOS		C		C		C		C	A	E		B
Approach Delay		31.2				21.9		19.0				44.8
Approach LOS		C				C		B				D
Queue Length 50th (m)		36.3		15.2		63.8		16.4	1.4	42.6		32.4
Queue Length 95th (m)		50.7		27.2		94.4		23.6	9.1	71.4		46.2
Internal Link Dist (m)		172.2				106.8			136.3			52.8
Turn Bay Length (m)									90.0	85.0		
Base Capacity (vph)		930		309		837		729	354	444		1187
Starvation Cap Reductn		0		0		0		0	0	0		0
Spillback Cap Reductn		0		0		0		0	0	0		0
Storage Cap Reductn		0		0		0		0	0	0		0
Reduced v/c Ratio		0.47		0.42		0.57		0.43	0.51	0.95		0.44

Intersection Summary	
Cycle Length: 100	
Actuated Cycle Length: 100	
Offset: 52 (52%), Referenced to phase 2:EBT and 6:WBTL, Start of Green	
Natural Cycle: 100	
Control Type: Actuated-Coordinated	

Lanes, Volumes, Timings  
3: Elgin & Laurier

2032 Future Background  
PM Peak Hour

Lane Group	Ø1	Ø5	Ø6	Ø13
Lane Configurations				
Traffic Volume (vph)				
Future Volume (vph)				
Satd. Flow (prot)				
Fit Permitted				
Satd. Flow (perm)				
Satd. Flow (RTOR)				
Lane Group Flow (vph)				
Turn Type				
Protected Phases	1	5	6	13
Permitted Phases				
Detector Phase				
Switch Phase				
Minimum Initial (s)	1.0	1.0	5.0	1.0
Minimum Split (s)	5.0	7.0	25.0	5.0
Total Split (s)	5.0	10.0	35.0	5.0
Total Split (%)	5%	10%	35%	5%
Yellow Time (s)	2.0	2.0	2.0	2.0
All-Red Time (s)	0.0	0.0	0.0	0.0
Lost Time Adjust (s)				
Total Lost Time (s)				
Lead/Lag	Lag	Lag		Lead
Lead-Lag Optimize?	Yes	Yes		Yes
Recall Mode	None	None	C-Max	None
Act Effct Green (s)				
Actuated g/C Ratio				
v/c Ratio				
Control Delay				
Queue Delay				
Total Delay				
LOS				
Approach Delay				
Approach LOS				
Queue Length 50th (m)				
Queue Length 95th (m)				
Internal Link Dist (m)				
Turn Bay Length (m)				
Base Capacity (vph)				
Starvation Cap Reductn				
Spillback Cap Reductn				
Storage Cap Reductn				
Reduced v/c Ratio				

Intersection Summary	
Cycle Length: 100	
Actuated Cycle Length: 100	
Offset: 52 (52%), Referenced to phase 2:EBT and 6:WBTL, Start of Green	
Natural Cycle: 100	
Control Type: Actuated-Coordinated	

Lanes, Volumes, Timings  
3: Elgin & Laurier

2032 Future Background  
PM Peak Hour

Maximum v/c Ratio: 0.95	Intersection LOS: C
Intersection Signal Delay: 30.1	ICU Level of Service D
Intersection Capacity Utilization 79.1%	
Analysis Period (min) 15	
# 95th percentile volume exceeds capacity, queue may be longer.	
Queue shown is maximum after two cycles.	

Splits and Phases: 3: Elgin & Laurier

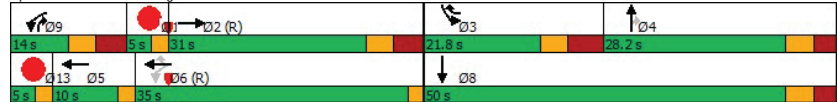

Lanes, Volumes, Timings  
4: Metcalfe & Gloucester

2032 Future Background  
PM Peak Hour

Lane Group	EBL	EBT	EBR	WBL	WBT	WBR	NBL	NBT	NBR	SBL	SBT	SBR
Lane Configurations					↑↑			↑↑↑				
Traffic Volume (vph)	0	0	0	0	209	127	114	442	0	0	0	0
Future Volume (vph)	0	0	0	0	209	127	114	442	0	0	0	0
Satd. Flow (prot)	0	0	0	0	2923	0	0	4716	0	0	0	0
Flt Permitted								0.990				
Satd. Flow (perm)	0	0	0	0	2923	0	0	4412	0	0	0	0
Satd. Flow (RTOR)					16			92				
Lane Group Flow (vph)	0	0	0	0	373	0	0	618	0	0	0	0
Turn Type					NA			Perm	NA			
Protected Phases					4			2				
Permitted Phases								2				
Detector Phase					4			2	2			
Switch Phase												
Minimum Initial (s)					10.0			10.0	10.0			
Minimum Split (s)					23.1			35.0	35.0			
Total Split (s)					30.0			45.0	45.0			
Total Split (%)					40.0%			60.0%	60.0%			
Yellow Time (s)					3.3			3.3	3.3			
All-Red Time (s)					1.8			1.7	1.7			
Lost Time Adjust (s)					0.0			0.0	0.0			
Total Lost Time (s)					5.1			5.0	5.0			
Lead/Lag												
Lead-Lag Optimize?												
Recall Mode					Max			C-Max	C-Max			
Act Effct Green (s)					24.9			35.0	40.0			
Actuated g/C Ratio					0.33			0.53	0.53			
v/c Ratio					0.38			0.26	0.26			
Control Delay					19.7			8.3	8.3			
Queue Delay					0.0			0.0	0.0			
Total Delay					19.7			8.3	8.3			
LOS					B			A	A			
Approach Delay					19.7			8.3	8.3			
Approach LOS					B			A	A			
Queue Length 50th (m)					19.9			13.4	13.4			
Queue Length 95th (m)					30.9			19.2	19.2			
Internal Link Dist (m)					34.9			48.3	35.0			51.7
Turn Bay Length (m)												
Base Capacity (vph)					981			2396	2396			
Starvation Cap Reductn					0			0	0			
Spillback Cap Reductn					0			0	0			
Storage Cap Reductn					0			0	0			
Reduced v/c Ratio					0.38			0.26	0.26			

Intersection Summary

Cycle Length: 75
Actuated Cycle Length: 75
Offset: 67 (89%), Referenced to phase 2:NBTL, Start of Green
Natural Cycle: 60
Control Type: Actuated-Coordinated

Lanes, Volumes, Timings  
4: Metcalfe & Gloucester

2032 Future Background  
PM Peak Hour

Maximum v/c Ratio: 0.38	Intersection LOS: B
Intersection Signal Delay: 12.6	ICU Level of Service A
Intersection Capacity Utilization 41.9%	
Analysis Period (min) 15	



Lanes, Volumes, Timings  
5: Elgin & Nepean/City Hall

2032 Future Background  
PM Peak Hour

Lane Group	EBL	EBT	EBR	WBL	WBT	WBR	NBL	NBT	NBR	SBL	SBT	SBR
Lane Configurations		↔		↔		↔		↔		↔	↔	↔
Traffic Volume (vph)	113	1	107	31	0	23	0	328	5	7	464	0
Future Volume (vph)	113	1	107	31	0	23	0	328	5	7	464	0
Satd. Flow (prot)	0	1491	0	1658	0	1483	0	3260	0	1658	3316	0
Flt Permitted		0.975		0.605						0.516		
Satd. Flow (perm)	0	1397	0	983	0	1286	0	3260	0	744	3316	0
Satd. Flow (RTOR)		55				48		2				
Lane Group Flow (vph)	0	246	0	34	0	26	0	370	0	8	516	0
Turn Type	Perm	NA	Perm	Perm	Perm	NA	Perm	NA	Perm	NA	NA	NA
Protected Phases		4						2				6
Permitted Phases	4			8		8				6		
Detector Phase	4	4		8		8		2		6		6
Switch Phase												
Minimum Initial (s)	10.0	10.0		10.0		10.0		10.0		10.0		10.0
Minimum Split (s)	25.1	25.1		25.1		25.1		31.4		31.4		31.4
Total Split (s)	45.0	45.0		45.0		45.0		50.0		50.0		50.0
Total Split (%)	45.0%	45.0%		45.0%		45.0%		50.0%		50.0%		50.0%
Yellow Time (s)	3.3	3.3		3.3		3.3		3.3		3.3		3.3
All-Red Time (s)	2.8	2.8		2.8		2.8		2.1		2.1		2.1
Lost Time Adjust (s)		0.0		0.0		0.0		0.0		0.0		0.0
Total Lost Time (s)		6.1		6.1		6.1		5.4		5.4		5.4
Lead/Lag	Lag	Lag		Lag		Lag						
Lead-Lag Optimize?	Yes	Yes		Yes		Yes						
Recall Mode	Max	Max		Max		Max		C-Max		C-Max		C-Max
Act Effct Green (s)		43.9		43.9		43.9		44.6		44.6		44.6
Actuated g/C Ratio		0.44		0.44		0.44		0.45		0.45		0.45
v/c Ratio		0.38		0.08		0.04		0.25		0.02		0.35
Control Delay		16.5		17.1		2.0		17.8		13.9		17.9
Queue Delay		0.0		0.0		0.0		0.0		0.0		0.0
Total Delay		16.5		17.1		2.0		17.8		13.9		17.9
LOS		B		B		A		B		B		B
Approach Delay		16.5				10.6		17.8				17.8
Approach LOS		B				B		B				B
Queue Length 50th (m)		23.7		3.7		0.0		22.7		0.6		39.5
Queue Length 95th (m)		42.7		9.6		2.2		32.5		m1.2		48.1
Internal Link Dist (m)		54.5				21.0		120.5				136.3
Turn Bay Length (m)										20.0		
Base Capacity (vph)		644		431		591		1455		331		1478
Starvation Cap Reductn		0		0		0		0		0		0
Spillback Cap Reductn		0		0		0		0		0		0
Storage Cap Reductn		0		0		0		0		0		0
Reduced v/c Ratio		0.38		0.08		0.04		0.25		0.02		0.35

<b>Intersection Summary</b>		
Cycle Length:	100	
Actuated Cycle Length:	100	
Offset:	0 (0%), Referenced to phase 2:NBT and 6:SBTL, Start of Green	
Natural Cycle:	65	
Control Type:	Actuated-Coordinated	

Lanes, Volumes, Timings  
5: Elgin & Nepean/City Hall

2032 Future Background  
PM Peak Hour

Lane Group	Ø3	Ø7
Lane Configurations		
Traffic Volume (vph)		
Future Volume (vph)		
Satd. Flow (prot)		
Flt Permitted		
Satd. Flow (perm)		
Satd. Flow (RTOR)		
Lane Group Flow (vph)		
Turn Type		
Protected Phases	3	7
Permitted Phases		
Detector Phase		
Switch Phase		
Minimum Initial (s)	1.0	1.0
Minimum Split (s)	5.0	5.0
Total Split (s)	5.0	5.0
Total Split (%)	5%	5%
Yellow Time (s)	2.0	2.0
All-Red Time (s)	0.0	0.0
Lost Time Adjust (s)		
Total Lost Time (s)		
Lead/Lag	Lead	Lead
Lead-Lag Optimize?	Yes	Yes
Recall Mode	None	None
Act Effct Green (s)		
Actuated g/C Ratio		
v/c Ratio		
Control Delay		
Queue Delay		
Total Delay		
LOS		
Approach Delay		
Approach LOS		
Queue Length 50th (m)		
Queue Length 95th (m)		
Internal Link Dist (m)		
Turn Bay Length (m)		
Base Capacity (vph)		
Starvation Cap Reductn		
Spillback Cap Reductn		
Storage Cap Reductn		
Reduced v/c Ratio		
Intersection Summary		

Lanes, Volumes, Timings  
5: Elgin & Nepean/City Hall

2032 Future Background  
PM Peak Hour

Maximum v/c Ratio: 0.38	Intersection LOS: B
Intersection Signal Delay: 17.2	ICU Level of Service C
Intersection Capacity Utilization 66.6%	
Analysis Period (min) 15	
m Volume for 95th percentile queue is metered by upstream signal.	

Splits and Phases: 5: Elgin & Nepean/City Hall

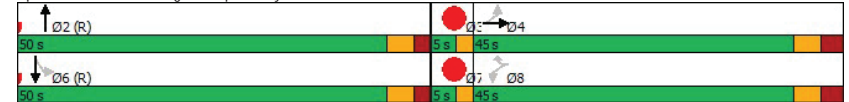

# Appendix I

Synchro Intersection Worksheets –2027 Future Total Conditions



Lanes, Volumes, Timings  
1: O'Connor & Laurier

2027 Future Total  
AM Peak Hour

Lane Group	EBL	EBT	EBR	WBL	WBT	WBR	NBL	NBT	NBR	SBL	SBT	SBR
Lane Configurations		↔		↔	↔						↔↔↔	
Traffic Volume (vph)	0	220	122	136	341	0	0	0	0	85	451	67
Future Volume (vph)	0	220	122	136	341	0	0	0	0	85	451	67
Satd. Flow (prot)	0	1435	0	1642	1712	0	0	0	0	0	4174	0
Flt Permitted				0.377							0.993	
Satd. Flow (perm)	0	1435	0	652	1712	0	0	0	0	0	3784	0
Satd. Flow (RTOR)												
Lane Group Flow (vph)	0	342	0	136	341	0	0	0	0	0	603	0
Turn Type		NA		pm+pt	NA					Perm	NA	
Protected Phases		2		9	6						4	
Permitted Phases				6						4		
Detector Phase		2		9	6					4	4	
Switch Phase												
Minimum Initial (s)		10.0		5.0	10.0					10.0	10.0	
Minimum Split (s)		23.9		10.8	21.9					22.5	22.5	
Total Split (s)		29.0		11.0	45.0					25.0	25.0	
Total Split (%)		38.7%		14.7%	60.0%					33.3%	33.3%	
Yellow Time (s)		3.3		3.3	3.3					3.3	3.3	
All-Red Time (s)		2.6		2.5	2.6					2.6	2.6	
Lost Time Adjust (s)		0.0		0.0	0.0					0.0	0.0	
Total Lost Time (s)		5.9		5.8	5.9					5.9	5.9	
Lead/Lag				Lead						Lag	Lag	
Lead-Lag Optimize?				Yes						Yes	Yes	
Recall Mode		C-Max		Max	C-Max					Max	Max	
Act Effct Green (s)		28.1		39.2	39.1					24.1	24.1	
Actuated g/C Ratio		0.37		0.52	0.52					0.32	0.32	
v/c Ratio		0.64		0.33	0.38					0.50	0.50	
Control Delay		25.8		7.1	6.7					22.3	22.3	
Queue Delay		0.0		0.0	0.0					0.0	0.0	
Total Delay		25.8		7.1	6.7					22.3	22.3	
LOS		C		A	A					C	C	
Approach Delay		25.8			6.8					22.3	22.3	
Approach LOS		C			A					C	C	
Queue Length 50th (m)		38.8		5.2	13.4					24.9	24.9	
Queue Length 95th (m)		65.9		9.4	19.8					34.9	34.9	
Internal Link Dist (m)		71.8			158.7			39.2		62.3	62.3	
Turn Bay Length (m)												
Base Capacity (vph)		537		409	892					1215	1215	
Starvation Cap Reductn		0		0	0					0	0	
Spillback Cap Reductn		0		0	0					0	0	
Storage Cap Reductn		0		0	0					0	0	
Reduced v/c Ratio		0.64		0.33	0.38					0.50	0.50	

Intersection Summary	
Cycle Length: 75	
Actuated Cycle Length: 75	
Offset: 63 (84%), Referenced to phase 2:EBT and 6:WBTL, Start of Green	
Natural Cycle: 70	
Control Type: Actuated-Coordinated	

Lanes, Volumes, Timings  
1: O'Connor & Laurier

2027 Future Total  
AM Peak Hour

Lane Group	Ø1	Ø3
Lane Configurations		
Traffic Volume (vph)		
Future Volume (vph)		
Satd. Flow (prot)		
Flt Permitted		
Satd. Flow (perm)		
Satd. Flow (RTOR)		
Lane Group Flow (vph)		
Turn Type		
Protected Phases	1	3
Permitted Phases		
Detector Phase		
Switch Phase		
Minimum Initial (s)	1.0	1.0
Minimum Split (s)	5.0	5.0
Total Split (s)	5.0	5.0
Total Split (%)	7%	7%
Yellow Time (s)	2.0	2.0
All-Red Time (s)	0.0	0.0
Lost Time Adjust (s)		
Total Lost Time (s)		
Lead/Lag	Lag	Lead
Lead-Lag Optimize?	Yes	Yes
Recall Mode	None	None
Act Effct Green (s)		
Actuated g/C Ratio		
v/c Ratio		
Control Delay		
Queue Delay		
Total Delay		
LOS		
Approach Delay		
Approach LOS		
Queue Length 50th (m)		
Queue Length 95th (m)		
Internal Link Dist (m)		
Turn Bay Length (m)		
Base Capacity (vph)		
Starvation Cap Reductn		
Spillback Cap Reductn		
Storage Cap Reductn		
Reduced v/c Ratio		

Intersection Summary	
Cycle Length: 75	
Actuated Cycle Length: 75	
Offset: 63 (84%), Referenced to phase 2:EBT and 6:WBTL, Start of Green	
Natural Cycle: 70	
Control Type: Actuated-Coordinated	

Lanes, Volumes, Timings  
1: O'Connor & Laurier

2027 Future Total  
AM Peak Hour

Maximum v/c Ratio: 0.64	Intersection LOS: B
Intersection Signal Delay: 17.9	ICU Level of Service B
Intersection Capacity Utilization 61.6%	
Analysis Period (min) 15	

Splits and Phases: 1: O'Connor & Laurier

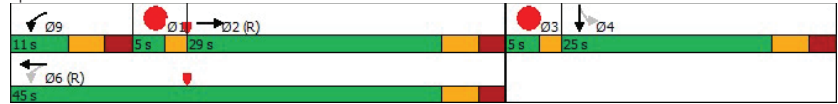

Lanes, Volumes, Timings  
2: Metcalfe & Laurier

2027 Future Total  
AM Peak Hour

Lane Group	EBL	EBT	EBR	WBL	WBT	WBR	NBL	NBT	NBR	SBL	SBT	SBR
Lane Configurations		↕			↕			↕				
Traffic Volume (vph)	22	293	0	0	401	258	96	671	75	0	0	0
Future Volume (vph)	22	293	0	0	401	258	96	671	75	0	0	0
Satd. Flow (prot)	0	1736	0	0	2518	0	0	4335	0	0	0	0
Flt Permitted		0.937						0.994				
Satd. Flow (perm)	0	1616	0	0	2518	0	0	4133	0	0	0	0
Satd. Flow (RTOR)												
Lane Group Flow (vph)	0	315	0	0	659	0	0	842	0	0	0	0
Turn Type	Perm	NA			NA		Perm	NA				
Protected Phases		2			6			4				
Permitted Phases	2						4					
Detector Phase	2	2			6		4	4				
Switch Phase												
Minimum Initial (s)	10.0	10.0			10.0		10.0	10.0				
Minimum Split (s)	37.0	37.0			37.0		33.0	33.0				
Total Split (s)	37.0	37.0			37.0		33.0	33.0				
Total Split (%)	49.3%	49.3%			49.3%		44.0%	44.0%				
Yellow Time (s)	3.3	3.3			3.3		3.3	3.3				
All-Red Time (s)	2.4	2.4			2.4		2.2	2.2				
Lost Time Adjust (s)		0.0			0.0			0.0				
Total Lost Time (s)		5.7			5.7			5.5				
Lead/Lag	Lag	Lag			Lag							
Lead-Lag Optimize?	Yes	Yes			Yes							
Recall Mode	C-Max	C-Max			C-Max		Max	Max				
Act Effct Green (s)		36.3			36.3			27.5				
Actuated g/C Ratio		0.48			0.48			0.37				
v/c Ratio		0.40			0.54			0.56				
Control Delay		19.3			15.6			15.2				
Queue Delay		0.0			0.0			0.4				
Total Delay		19.3			15.6			15.6				
LOS		B			B			B				
Approach Delay		19.3			15.6			15.6				
Approach LOS		B			B			B				
Queue Length 50th (m)		32.0			32.4			35.3				
Queue Length 95th (m)		57.1			47.2			47.2				
Internal Link Dist (m)		158.7			93.1			51.7			65.1	
Turn Bay Length (m)												
Base Capacity (vph)		782			1218			1515				
Starvation Cap Reductn		0			0			249				
Spillback Cap Reductn		0			0			0				
Storage Cap Reductn		0			0			0				
Reduced v/c Ratio		0.40			0.54			0.67				

Intersection Summary

Cycle Length: 75
Actuated Cycle Length: 75
Offset: 48 (64%), Referenced to phase 2:EBTL and 6:WBT, Start of Green
Natural Cycle: 75
Control Type: Actuated-Coordinated

Lanes, Volumes, Timings  
2: Metcalfe & Laurier

2027 Future Total  
AM Peak Hour

Lane Group	Ø1	Ø5
Lane Configurations		
Traffic Volume (vph)		
Future Volume (vph)		
Satd. Flow (prot)		
Flt Permitted		
Satd. Flow (perm)		
Satd. Flow (RTOR)		
Lane Group Flow (vph)		
Turn Type		
Protected Phases	1	5
Permitted Phases		
Detector Phase		
Switch Phase		
Minimum Initial (s)	1.0	1.0
Minimum Split (s)	5.0	5.0
Total Split (s)	5.0	5.0
Total Split (%)	7%	7%
Yellow Time (s)	2.0	2.0
All-Red Time (s)	0.0	0.0
Lost Time Adjust (s)		
Total Lost Time (s)		
Lead/Lag	Lead	Lead
Lead-Lag Optimize?	Yes	Yes
Recall Mode	None	None
Act Effct Green (s)		
Actuated g/C Ratio		
v/c Ratio		
Control Delay		
Queue Delay		
Total Delay		
LOS		
Approach Delay		
Approach LOS		
Queue Length 50th (m)		
Queue Length 95th (m)		
Internal Link Dist (m)		
Turn Bay Length (m)		
Base Capacity (vph)		
Starvation Cap Reductn		
Spillback Cap Reductn		
Storage Cap Reductn		
Reduced v/c Ratio		
Intersection Summary		

Lanes, Volumes, Timings  
2: Metcalfe & Laurier

2027 Future Total  
AM Peak Hour

Maximum v/c Ratio: 0.56	Intersection LOS: B
Intersection Signal Delay: 16.3	ICU Level of Service C
Intersection Capacity Utilization 65.4%	
Analysis Period (min) 15	



Lanes, Volumes, Timings  
3: Elgin & Laurier/City Hall

2027 Future Total  
AM Peak Hour

Lane Group	EBL	EBT	EBR	WBL	WBT	WBR	NBL	NBT	NBR	SBL	SBT	SBR
Lane Configurations		↕		↕	↕	↕		↕	↕	↕	↕	
Traffic Volume (vph)	0	288	59	209	498	538	0	208	59	361	367	171
Future Volume (vph)	0	288	59	209	498	538	0	208	59	361	367	171
Satd. Flow (prot)	0	3037	0	1658	1745	1483	0	3316	1483	3154	2417	0
Fit Permitted				0.527						0.950		
Satd. Flow (perm)	0	3037	0	765	1745	920	0	3316	680	1869	2417	0
Satd. Flow (RTOR)						238			149		96	
Lane Group Flow (vph)	0	347	0	209	498	538	0	208	59	361	538	0
Turn Type		NA		custom	NA	custom		NA	pm+ov	Prot	NA	
Protected Phases		2		9	5	6		3		9	3	8
Permitted Phases				6		6				4		
Detector Phase		2		9	5	6		3		4	3	8
Switch Phase												
Minimum Initial (s)		5.0		5.0		10.0		10.0	5.0	10.0	10.0	
Minimum Split (s)		30.0		12.0		20.7		28.2	12.0	20.7	28.2	
Total Split (s)		31.0		15.0		20.8		28.2	15.0	20.8	49.0	
Total Split (%)		31.0%		15.0%		20.8%		28.2%	15.0%	20.8%	49.0%	
Yellow Time (s)		3.3		3.3		3.3		3.3	3.3	3.3	3.3	
All-Red Time (s)		3.7		3.7		4.4		2.9	3.7	4.4	2.9	
Lost Time Adjust (s)		0.0		0.0		0.0		0.0	0.0	0.0	0.0	
Total Lost Time (s)		7.0		7.0		7.7		6.2	7.0	7.7	6.2	
Lead/Lag				Lead		Lead		Lag	Lead		Lead	
Lead-Lag Optimize?				Yes		Yes		Yes	Yes		Yes	
Recall Mode		C-Max		Max		None		Max	Max		None	Max
Act Effct Green (s)		29.0		37.0		49.0		22.0	29.2		13.1	42.8
Actuated g/C Ratio		0.29		0.37		0.49		0.22	0.29		0.13	0.43
v/c Ratio		0.39		0.59		0.58		0.29	0.16		0.87	0.49
Control Delay		30.1		27.3		21.7		33.7	0.9		65.4	18.6
Queue Delay		0.0		0.0		0.0		0.0	0.0		0.0	0.0
Total Delay		30.1		27.3		21.7		33.7	0.9		65.4	18.6
LOS		C		C		C		C	A		E	B
Approach Delay		30.1				28.6		26.5				37.4
Approach LOS		C				C		C				D
Queue Length 50th (m)		28.2		25.3		66.2		39.9		17.7	0.0	35.8
Queue Length 95th (m)		41.0		41.4		97.5		#89.7		27.8	0.0	#60.1
Internal Link Dist (m)		55.2				106.8				136.3		
Turn Bay Length (m)									90.0		85.0	
Base Capacity (vph)		880		354		855		594		729	368	413
Starvation Cap Reductn		0		0		0		0		0	0	0
Spillback Cap Reductn		0		0		0		0		0	0	0
Storage Cap Reductn		0		0		0		0		0	0	0
Reduced v/c Ratio		0.39		0.59		0.58		0.91		0.29	0.16	0.87

Intersection Summary

Cycle Length: 100  
 Actuated Cycle Length: 100  
 Offset: 64 (64%), Referenced to phase 2:EBT and 6:WBTL, Start of Green  
 Natural Cycle: 100  
 Control Type: Actuated-Coordinated

Lanes, Volumes, Timings  
3: Elgin & Laurier/City Hall

2027 Future Total  
AM Peak Hour

Lane Group	Ø1	Ø5	Ø6	Ø13
Lane Configurations				
Traffic Volume (vph)				
Future Volume (vph)				
Satd. Flow (prot)				
Fit Permitted				
Satd. Flow (perm)				
Satd. Flow (RTOR)				
Lane Group Flow (vph)				
Turn Type				
Protected Phases	1	5	6	13
Permitted Phases				
Detector Phase				
Switch Phase				
Minimum Initial (s)	1.0	1.0	5.0	1.0
Minimum Split (s)	5.0	7.0	25.0	5.0
Total Split (s)	5.0	10.0	36.0	5.0
Total Split (%)	5%	10%	36%	5%
Yellow Time (s)	2.0	2.0	2.0	2.0
All-Red Time (s)	0.0	0.0	0.0	0.0
Lost Time Adjust (s)				
Total Lost Time (s)				
Lead/Lag	Lag	Lag		Lead
Lead-Lag Optimize?	Yes	Yes		Yes
Recall Mode	None	None	C-Max	None
Act Effct Green (s)				
Actuated g/C Ratio				
v/c Ratio				
Control Delay				
Queue Delay				
Total Delay				
LOS				
Approach Delay				
Approach LOS				
Queue Length 50th (m)				
Queue Length 95th (m)				
Internal Link Dist (m)				
Turn Bay Length (m)				
Base Capacity (vph)				
Starvation Cap Reductn				
Spillback Cap Reductn				
Storage Cap Reductn				
Reduced v/c Ratio				

Intersection Summary

Lanes, Volumes, Timings  
3: Elgin & Laurier/City Hall

2027 Future Total  
AM Peak Hour

Maximum v/c Ratio: 0.91	Intersection LOS: C
Intersection Signal Delay: 31.4	ICU Level of Service E
Intersection Capacity Utilization 83.8%	
Analysis Period (min) 15	
# 95th percentile volume exceeds capacity, queue may be longer.	
Queue shown is maximum after two cycles.	

Splits and Phases: 3: Elgin & Laurier/City Hall

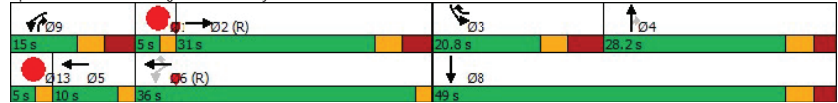

Lanes, Volumes, Timings  
4: Metcalfe & Gloucester

2027 Future Total  
AM Peak Hour

Lane Group	EBL	EBT	EBR	WBL	WBT	WBR	NBL	NBT	NBR	SBL	SBT	SBR
Lane Configurations					↑↑			↑↑↑				
Traffic Volume (vph)	0	0	0	0	164	74	247	773	0	0	0	0
Future Volume (vph)	0	0	0	0	164	74	247	773	0	0	0	0
Satd. Flow (prot)	0	0	0	0	2845	0	0	4696	0	0	0	0
Flt Permitted								0.988				
Satd. Flow (perm)	0	0	0	0	2845	0	0	4316	0	0	0	0
Satd. Flow (RTOR)					28			89				
Lane Group Flow (vph)	0	0	0	0	238	0	0	1020	0	0	0	0
Turn Type					NA			Perm	NA			
Protected Phases					4			2				
Permitted Phases								2				
Detector Phase					4			2	2			
Switch Phase												
Minimum Initial (s)					10.0			10.0	10.0			
Minimum Split (s)					23.1			35.0	35.0			
Total Split (s)					25.0			50.0	50.0			
Total Split (%)					33.3%			66.7%	66.7%			
Yellow Time (s)					3.3			3.3	3.3			
All-Red Time (s)					1.8			1.7	1.7			
Lost Time Adjust (s)					0.0			0.0	0.0			
Total Lost Time (s)					5.1			5.0	5.0			
Lead/Lag												
Lead-Lag Optimize?												
Recall Mode					Max			C-Max	C-Max			
Act Effct Green (s)					19.9			35.0	45.0			
Actuated g/C Ratio					0.27			0.60	0.60			
v/c Ratio					0.31			0.39	0.39			
Control Delay					20.6			7.6	7.6			
Queue Delay					0.0			0.0	0.0			
Total Delay					20.6			7.6	7.6			
LOS					C			A	A			
Approach Delay					20.6			7.6	7.6			
Approach LOS					C			A	A			
Queue Length 50th (m)					12.3			22.1	22.1			
Queue Length 95th (m)					21.4			29.6	29.6			
Internal Link Dist (m)						34.9		48.3	35.0		51.7	
Turn Bay Length (m)												
Base Capacity (vph)					775			2625	2625			
Starvation Cap Reductn					0			0	0			
Spillback Cap Reductn					0			111	111			
Storage Cap Reductn					0			0	0			
Reduced v/c Ratio					0.31			0.41	0.41			

Intersection Summary

Cycle Length: 75
Actuated Cycle Length: 75
Offset: 73 (97%), Referenced to phase 2:NBTL, Start of Green
Natural Cycle: 60
Control Type: Actuated-Coordinated

Lanes, Volumes, Timings  
4: Metcalfe & Gloucester

2027 Future Total  
AM Peak Hour

Maximum v/c Ratio: 0.39	Intersection LOS: B
Intersection Signal Delay: 10.0	ICU Level of Service A
Intersection Capacity Utilization 43.3%	
Analysis Period (min) 15	

Splits and Phases: 4: Metcalfe & Gloucester



Lanes, Volumes, Timings  
5: Elgin & Nepean/City Hall

2027 Future Total  
AM Peak Hour

Lane Group	EBL	EBT	EBR	WBL	WBT	WBR	NBL	NBT	NBR	SBL	SBT	SBR
Lane Configurations		↔		↔		↔		↔		↔	↔	↔
Traffic Volume (vph)	31	7	31	1	0	9	0	274	43	17	330	0
Future Volume (vph)	31	7	31	1	0	9	0	274	43	17	330	0
Satd. Flow (prot)	0	1506	0	1658	0	1483	0	3077	0	1658	3252	0
Flt Permitted		0.978		0.712						0.560		
Satd. Flow (perm)	0	1427	0	1188	0	1294	0	3077	0	855	3252	0
Satd. Flow (RTOR)		31				53		33				
Lane Group Flow (vph)	0	69	0	1	0	9	0	317	0	17	330	0
Turn Type	Perm	NA	Perm	Perm	Perm	NA	Perm	NA	Perm	NA	NA	NA
Protected Phases		4						2				6
Permitted Phases	4			8		8				6		
Detector Phase	4	4		8		8		2		6		6
Switch Phase												
Minimum Initial (s)	10.0	10.0		10.0		10.0		10.0		10.0		10.0
Minimum Split (s)	25.1	25.1		25.1		25.1		31.4		31.4		31.4
Total Split (s)	27.0	27.0		27.0		27.0		58.0		58.0		58.0
Total Split (%)	30.0%	30.0%		30.0%		30.0%		64.4%		64.4%		64.4%
Yellow Time (s)	3.3	3.3		3.3		3.3		3.3		3.3		3.3
All-Red Time (s)	2.8	2.8		2.8		2.8		2.1		2.1		2.1
Lost Time Adjust (s)		0.0		0.0		0.0		0.0		0.0		0.0
Total Lost Time (s)		6.1		6.1		6.1		5.4		5.4		5.4
Lead/Lag	Lag	Lag		Lag		Lag						
Lead-Lag Optimize?	Yes	Yes		Yes		Yes						
Recall Mode	Max	Max		Max		Max		C-Max		C-Max		C-Max
Act Effct Green (s)		25.9		25.9		25.9		52.6		52.6		52.6
Actuated g/C Ratio		0.29		0.29		0.29		0.58		0.58		0.58
v/c Ratio		0.16		0.00		0.02		0.17		0.03		0.17
Control Delay		16.1		23.0		0.1		8.0		8.2		8.9
Queue Delay		0.0		0.0		0.0		0.0		0.0		0.0
Total Delay		16.1		23.0		0.1		8.0		8.2		8.9
LOS		B		C		A		A		A		A
Approach Delay		16.1				2.4		8.0				8.9
Approach LOS		B				A		A				A
Queue Length 50th (m)		4.8		0.1		0.0		10.9		1.2		12.8
Queue Length 95th (m)		14.5		1.3		0.0		16.9		3.8		19.0
Internal Link Dist (m)		54.5				21.0		120.5				136.3
Turn Bay Length (m)										20.0		
Base Capacity (vph)		432		341		410		1812		499		1900
Starvation Cap Reductn		0		0		0		0		0		0
Spillback Cap Reductn		0		0		0		0		0		0
Storage Cap Reductn		0		0		0		0		0		0
Reduced v/c Ratio		0.16		0.00		0.02		0.17		0.03		0.17

<b>Intersection Summary</b>												
Cycle Length: 90												
Actuated Cycle Length: 90												
Offset: 0 (0%), Referenced to phase 2:NBT and 6:SBTL, Start of Green												
Natural Cycle: 65												
Control Type: Actuated-Coordinated												

Lanes, Volumes, Timings  
5: Elgin & Nepean/City Hall

2027 Future Total  
AM Peak Hour

Lane Group	Ø3	Ø7
Lane Configurations		
Traffic Volume (vph)		
Future Volume (vph)		
Satd. Flow (prot)		
Flt Permitted		
Satd. Flow (perm)		
Satd. Flow (RTOR)		
Lane Group Flow (vph)		
Turn Type		
Protected Phases	3	7
Permitted Phases		
Detector Phase		
Switch Phase		
Minimum Initial (s)	1.0	1.0
Minimum Split (s)	5.0	5.0
Total Split (s)	5.0	5.0
Total Split (%)	6%	6%
Yellow Time (s)	2.0	2.0
All-Red Time (s)	0.0	0.0
Lost Time Adjust (s)		
Total Lost Time (s)		
Lead/Lag	Lead	Lead
Lead-Lag Optimize?	Yes	Yes
Recall Mode	None	None
Act Effct Green (s)		
Actuated g/C Ratio		
v/c Ratio		
Control Delay		
Queue Delay		
Total Delay		
LOS		
Approach Delay		
Approach LOS		
Queue Length 50th (m)		
Queue Length 95th (m)		
Internal Link Dist (m)		
Turn Bay Length (m)		
Base Capacity (vph)		
Starvation Cap Reductn		
Spillback Cap Reductn		
Storage Cap Reductn		
Reduced v/c Ratio		
Intersection Summary		

Lanes, Volumes, Timings  
5: Elgin & Nepean/City Hall

2027 Future Total  
AM Peak Hour

Maximum v/c Ratio: 0.17	Intersection LOS: A
Intersection Signal Delay: 9.1	ICU Level of Service C
Intersection Capacity Utilization 66.3%	
Analysis Period (min) 15	

Splits and Phases: 5: Elgin & Nepean/City Hall

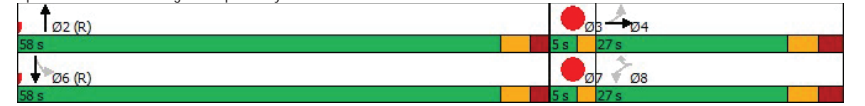

Lanes, Volumes, Timings  
6: Access & Laurier

2027 Future Total  
AM Peak Hour

Lane Group	EBT	EBR	WBL	WBT	NBL	NBR
Lane Configurations	↔		↔		↔	
Traffic Volume (vph)	338	6	3	711	13	5
Future Volume (vph)	338	6	3	711	13	5
Satd. Flow (prot)	1742	0	0	1745	1620	0
Flt Permitted				0.965		
Satd. Flow (perm)	1742	0	0	1745	1620	0
Lane Group Flow (vph)	344	0	0	714	18	0
Sign Control	Free		Free		Stop	
<b>Intersection Summary</b>						
Control Type: Unsignalized						
Intersection Capacity Utilization 52.0%						
ICU Level of Service A						
Analysis Period (min) 15						

HCM 2010 TWSC  
6: Access & Laurier

2027 Future Total  
AM Peak Hour

<b>Intersection</b>						
Int Delay, s/veh	0.3					
Movement	EBT	EBR	WBL	WBT	NBL	NBR
Lane Configurations	↔		↔		↔	
Traffic Vol, veh/h	338	6	3	711	13	5
Future Vol, veh/h	338	6	3	711	13	5
Conflicting Peds, #/hr	0	0	0	0	0	0
Sign Control	Free	Free	Free	Free	Stop	Stop
RT Channelized	-	None	-	None	-	None
Storage Length	-	-	-	-	0	-
Veh in Median Storage, #	0	-	-	0	0	-
Grade, %	0	-	-	0	0	-
Peak Hour Factor	100	100	100	100	100	100
Heavy Vehicles, %	2	2	2	2	2	2
Mvmt Flow	338	6	3	711	13	5
Major/Minor	Major1	Major2	Minor1			
Conflicting Flow All	0	0	344	0	1058	341
Stage 1	-	-	-	-	341	-
Stage 2	-	-	-	-	717	-
Critical Hdwy	-	-	4.12	-	6.42	6.22
Critical Hdwy Stg 1	-	-	-	-	5.42	-
Critical Hdwy Stg 2	-	-	-	-	5.42	-
Follow-up Hdwy	-	-	2.218	-	3.518	3.318
Pot Cap-1 Maneuver	-	-	1215	-	249	701
Stage 1	-	-	-	-	720	-
Stage 2	-	-	-	-	484	-
Platoon blocked, %	-	-	-	-	-	-
Mov Cap-1 Maneuver	-	-	1215	-	248	701
Mov Cap-2 Maneuver	-	-	-	-	248	-
Stage 1	-	-	-	-	720	-
Stage 2	-	-	-	-	482	-
Approach	EB	WB	NB			
HCM Control Delay, s	0	0	17.7			
HCM LOS			C			
Minor Lane/Major Mvmt	NBLn1	EBT	EBR	WBL	WBT	
Capacity (veh/h)	302	-	-	1215	-	
HCM Lane V/C Ratio	0.06	-	-	0.002	-	
HCM Control Delay (s)	17.7	-	-	8	0	
HCM Lane LOS	C	-	-	A	A	
HCM 95th %tile Q(veh)	0.2	-	-	0	-	



Lanes, Volumes, Timings  
1: O'Connor & Laurier

2027 Future Total  
PM Peak Hour

Lane Group	EBL	EBT	EBR	WBL	WBT	WBR	NBL	NBT	NBR	SBL	SBT	SBR
Lane Configurations		↔	↔	↔	↔	↔	↔	↔	↔	↔	↔	↔
Traffic Volume (vph)	0	214	95	181	277	0	0	0	0	51	544	44
Future Volume (vph)	0	214	95	181	277	0	0	0	0	51	544	44
Satd. Flow (prot)	0	1480	0	1642	1745	0	0	0	0	0	4480	0
Flt Permitted				0.375							0.996	
Satd. Flow (perm)	0	1480	0	648	1745	0	0	0	0	0	4249	0
Satd. Flow (RTOR)												
Lane Group Flow (vph)	0	344	0	201	308	0	0	0	0	0	710	0
Turn Type		NA		pm+pt	NA					Perm	NA	
Protected Phases		2		9	6							4
Permitted Phases				6							4	
Detector Phase		2		9	6						4	4
Switch Phase												
Minimum Initial (s)		10.0		5.0	10.0					10.0	10.0	
Minimum Split (s)		23.9		10.8	21.9					22.5	22.5	
Total Split (s)		29.0		11.0	45.0					25.0	25.0	
Total Split (%)		38.7%		14.7%	60.0%					33.3%	33.3%	
Yellow Time (s)		3.3		3.3	3.3					3.3	3.3	
All-Red Time (s)		2.6		2.5	2.6					2.6	2.6	
Lost Time Adjust (s)		0.0		0.0	0.0					0.0	0.0	
Total Lost Time (s)		5.9		5.8	5.9					5.9	5.9	
Lead/Lag				Lead						Lag	Lag	
Lead-Lag Optimize?				Yes						Yes	Yes	
Recall Mode		C-Max		Max	C-Max					Max	Max	
Act Effct Green (s)		28.1		39.2	39.1						24.1	
Actuated g/C Ratio		0.37		0.52	0.52						0.32	
v/c Ratio		0.62		0.49	0.34						0.52	
Control Delay		25.1		23.0	16.5						22.4	
Queue Delay		0.0		0.0	0.0						0.0	
Total Delay		25.1		23.0	16.5						22.4	
LOS		C		C	B						C	
Approach Delay		25.1			19.0						22.4	
Approach LOS		C			B						C	
Queue Length 50th (m)		38.8		19.2	26.3						29.6	
Queue Length 95th (m)		65.3		38.1	47.6						40.4	
Internal Link Dist (m)		71.8			158.7			39.2			62.3	
Turn Bay Length (m)												
Base Capacity (vph)		554		407	909						1365	
Starvation Cap Reductn		0		0	0						0	
Spillback Cap Reductn		0		0	0						0	
Storage Cap Reductn		0		0	0						0	
Reduced v/c Ratio		0.62		0.49	0.34						0.52	

Intersection Summary	
Cycle Length: 75	
Actuated Cycle Length: 75	
Offset: 22 (29%), Referenced to phase 2:EBT and 6:WBTL, Start of Green	
Natural Cycle: 70	
Control Type: Actuated-Coordinated	

Lanes, Volumes, Timings  
1: O'Connor & Laurier

2027 Future Total  
PM Peak Hour

Lane Group	Ø1	Ø3
Lane Configurations		
Traffic Volume (vph)		
Future Volume (vph)		
Satd. Flow (prot)		
Flt Permitted		
Satd. Flow (perm)		
Satd. Flow (RTOR)		
Lane Group Flow (vph)		
Turn Type		
Protected Phases	1	3
Permitted Phases		
Detector Phase		
Switch Phase		
Minimum Initial (s)	1.0	1.0
Minimum Split (s)	5.0	5.0
Total Split (s)	5.0	5.0
Total Split (%)	7%	7%
Yellow Time (s)	2.0	2.0
All-Red Time (s)	0.0	0.0
Lost Time Adjust (s)		
Total Lost Time (s)		
Lead/Lag	Lag	Lead
Lead-Lag Optimize?	Yes	Yes
Recall Mode	None	None
Act Effct Green (s)		
Actuated g/C Ratio		
v/c Ratio		
Control Delay		
Queue Delay		
Total Delay		
LOS		
Approach Delay		
Approach LOS		
Queue Length 50th (m)		
Queue Length 95th (m)		
Internal Link Dist (m)		
Turn Bay Length (m)		
Base Capacity (vph)		
Starvation Cap Reductn		
Spillback Cap Reductn		
Storage Cap Reductn		
Reduced v/c Ratio		

Intersection Summary	
Cycle Length: 75	
Actuated Cycle Length: 75	
Offset: 22 (29%), Referenced to phase 2:EBT and 6:WBTL, Start of Green	
Natural Cycle: 70	
Control Type: Actuated-Coordinated	

Lanes, Volumes, Timings  
1: O'Connor & Laurier

2027 Future Total  
PM Peak Hour

Maximum v/c Ratio: 0.62	Intersection LOS: C
Intersection Signal Delay: 21.9	ICU Level of Service B
Intersection Capacity Utilization 62.0%	
Analysis Period (min) 15	

Splits and Phases: 1: O'Connor & Laurier

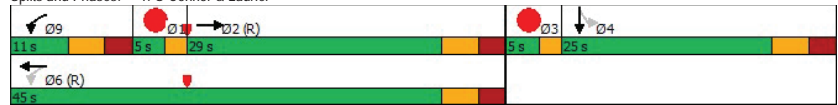

Lanes, Volumes, Timings  
2: Metcalfe & Laurier

2027 Future Total  
PM Peak Hour

Lane Group	EBL	EBT	EBR	WBL	WBT	WBR	NBL	NBT	NBR	SBL	SBT	SBR
Lane Configurations		↕			↕			↕				
Traffic Volume (vph)	10	255	0	0	399	167	33	395	128	0	0	0
Future Volume (vph)	10	255	0	0	399	167	33	395	128	0	0	0
Satd. Flow (prot)	0	1742	0	0	2815	0	0	3740	0	0	0	0
Flt Permitted		0.974						0.997				
Satd. Flow (perm)	0	1692	0	0	2815	0	0	3658	0	0	0	0
Satd. Flow (RTOR)												
Lane Group Flow (vph)	0	294	0	0	629	0	0	618	0	0	0	0
Turn Type	Perm	NA			NA		Perm	NA				
Protected Phases		2			6			4				
Permitted Phases	2						4					
Detector Phase	2	2			6		4	4				
Switch Phase												
Minimum Initial (s)	10.0	10.0			10.0		10.0	10.0				
Minimum Split (s)	37.0	37.0			37.0		19.5	19.5				
Total Split (s)	40.0	40.0			40.0		30.0	30.0				
Total Split (%)	53.3%	53.3%			53.3%		40.0%	40.0%				
Yellow Time (s)	3.3	3.3			3.3		3.3	3.3				
All-Red Time (s)	2.4	2.4			2.4		2.2	2.2				
Lost Time Adjust (s)		0.0			0.0			0.0				
Total Lost Time (s)		5.7			5.7			5.5				
Lead/Lag	Lag	Lag			Lag							
Lead-Lag Optimize?	Yes	Yes			Yes							
Recall Mode	C-Max	C-Max			C-Max		Max	Max				
Act Effct Green (s)		39.3			39.3			24.5				
Actuated g/C Ratio		0.52			0.52			0.33				
v/c Ratio		0.33			0.43			0.52				
Control Delay		6.5			12.1			17.8				
Queue Delay		0.0			0.0			0.3				
Total Delay		6.5			12.1			18.1				
LOS		A			B			B				
Approach Delay		6.5			12.1			18.1				
Approach LOS		A			B			B				
Queue Length 50th (m)		8.9			26.7			16.7				
Queue Length 95th (m)		13.4			38.4			21.4				
Internal Link Dist (m)		158.7			97.3			51.7			65.1	
Turn Bay Length (m)												
Base Capacity (vph)		886			1475			1194				
Starvation Cap Reductn		0			0			174				
Spillback Cap Reductn		0			0			0				
Storage Cap Reductn		0			0			0				
Reduced v/c Ratio		0.33			0.43			0.61				

Intersection Summary

Cycle Length: 75
Actuated Cycle Length: 75
Offset: 30 (40%), Referenced to phase 2:EBTL and 6:WBT, Start of Green
Natural Cycle: 65
Control Type: Actuated-Coordinated

Lanes, Volumes, Timings  
2: Metcalfe & Laurier

2027 Future Total  
PM Peak Hour

Lane Group	Ø1	Ø5
Lane Configurations		
Traffic Volume (vph)		
Future Volume (vph)		
Satd. Flow (prot)		
Flt Permitted		
Satd. Flow (perm)		
Satd. Flow (RTOR)		
Lane Group Flow (vph)		
Turn Type		
Protected Phases	1	5
Permitted Phases		
Detector Phase		
Switch Phase		
Minimum Initial (s)	1.0	1.0
Minimum Split (s)	5.0	5.0
Total Split (s)	5.0	5.0
Total Split (%)	7%	7%
Yellow Time (s)	2.0	2.0
All-Red Time (s)	0.0	0.0
Lost Time Adjust (s)		
Total Lost Time (s)		
Lead/Lag	Lead	Lead
Lead-Lag Optimize?	Yes	Yes
Recall Mode	None	None
Act Effct Green (s)		
Actuated g/C Ratio		
v/c Ratio		
Control Delay		
Queue Delay		
Total Delay		
LOS		
Approach Delay		
Approach LOS		
Queue Length 50th (m)		
Queue Length 95th (m)		
Internal Link Dist (m)		
Turn Bay Length (m)		
Base Capacity (vph)		
Starvation Cap Reductn		
Spillback Cap Reductn		
Storage Cap Reductn		
Reduced v/c Ratio		
Intersection Summary		

Lanes, Volumes, Timings  
2: Metcalfe & Laurier

2027 Future Total  
PM Peak Hour

Maximum v/c Ratio: 0.52	
Intersection Signal Delay: 13.4	Intersection LOS: B
Intersection Capacity Utilization 48.6%	ICU Level of Service A
Analysis Period (min) 15	

Splits and Phases: 2: Metcalfe & Laurier

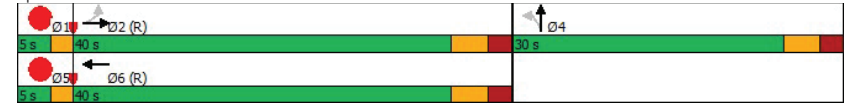

Lanes, Volumes, Timings  
3: Elgin & Laurier

2027 Future Total  
PM Peak Hour

Lane Group	EBL	EBT	EBR	WBL	WBT	WBR	NBL	NBT	NBR	SBL	SBT	SBR
Lane Configurations		↕↕		↕	↕	↕		↕↕	↕	↕↕	↕↕	
Traffic Volume (vph)	0	364	30	117	431	413	0	273	161	382	354	110
Future Volume (vph)	0	364	30	117	431	413	0	273	161	382	354	110
Satd. Flow (prot)	0	3203	0	1642	1745	1483	0	3316	1483	3154	2627	0
Flt Permitted				0.462						0.950		
Satd. Flow (perm)	0	3203	0	692	1745	976	0	3316	680	2237	2627	0
Satd. Flow (RTOR)						214			149		52	
Lane Group Flow (vph)	0	437	0	130	479	459	0	303	179	424	515	0
Turn Type		NA		custom	NA	custom		NA	pm+ov	Prot	NA	
Protected Phases		2		9	5	6		3	4	9	3	8
Permitted Phases				6		6			4			
Detector Phase		2		9	5	6		3	4	9	3	8
Switch Phase												
Minimum Initial (s)		5.0		5.0		10.0		10.0	5.0	10.0		10.0
Minimum Split (s)		30.0		12.0		20.7		28.2	12.0	20.7		28.2
Total Split (s)		31.0		14.0		21.8		28.2	14.0	21.8		50.0
Total Split (%)		31.0%		14.0%		21.8%		28.2%	14.0%	21.8%		50.0%
Yellow Time (s)		3.3		3.3		3.3		3.3	3.3	3.3		3.3
All-Red Time (s)		3.7		3.7		4.4		2.9	3.7	4.4		2.9
Lost Time Adjust (s)		0.0		0.0		0.0		0.0	0.0	0.0		0.0
Total Lost Time (s)		7.0		7.0		7.7		6.2	7.0	7.7		6.2
Lead/Lag				Lead		Lead		Lag	Lead		Lead	
Lead-Lag Optimize?				Yes		Yes		Yes	Yes		Yes	
Recall Mode		C-Max		None		None		Max	None	None		Max
Act Effct Green (s)		29.0		35.0		48.0		22.0	28.2	14.1		43.8
Actuated g/C Ratio		0.29		0.35		0.48		0.22	0.28	0.14		0.44
v/c Ratio		0.47		0.42		0.57		0.42	0.51	0.95		0.44
Control Delay		31.2		23.1		22.0		25.2	8.5	76.6		18.8
Queue Delay		0.0		0.0		0.0		0.0	0.0	0.0		0.0
Total Delay		31.2		23.1		22.0		25.2	8.5	76.6		18.8
LOS		C		C		C		C	A	E		B
Approach Delay		31.2				21.9		19.0				44.9
Approach LOS		C				C		B				D
Queue Length 50th (m)		36.5		15.2		64.1		29.7	16.1	1.3	42.6	31.7
Queue Length 95th (m)		51.0		27.2		94.8		#58.5	23.2	9.0	#71.4	45.3
Internal Link Dist (m)		50.9				106.8			136.3			52.8
Turn Bay Length (m)									90.0	85.0		
Base Capacity (vph)		929		308		837		600	729	354	444	1179
Starvation Cap Reductn		0		0		0		0	0	0		0
Spillback Cap Reductn		0		0		0		0	0	0		0
Storage Cap Reductn		0		0		0		0	0	0		0
Reduced v/c Ratio		0.47		0.42		0.57		0.77	0.42	0.51		0.95

Intersection Summary	
Cycle Length: 100	
Actuated Cycle Length: 100	
Offset: 52 (52%), Referenced to phase 2:EBT and 6:WBTL, Start of Green	
Natural Cycle: 100	
Control Type: Actuated-Coordinated	

Lanes, Volumes, Timings  
3: Elgin & Laurier

2027 Future Total  
PM Peak Hour

Lane Group	Ø1	Ø5	Ø6	Ø13
Lane Configurations				
Traffic Volume (vph)				
Future Volume (vph)				
Satd. Flow (prot)				
Flt Permitted				
Satd. Flow (perm)				
Satd. Flow (RTOR)				
Lane Group Flow (vph)				
Turn Type				
Protected Phases	1	5	6	13
Permitted Phases				
Detector Phase				
Switch Phase				
Minimum Initial (s)	1.0	1.0	5.0	1.0
Minimum Split (s)	5.0	7.0	25.0	5.0
Total Split (s)	5.0	10.0	35.0	5.0
Total Split (%)	5%	10%	35%	5%
Yellow Time (s)	2.0	2.0	2.0	2.0
All-Red Time (s)	0.0	0.0	0.0	0.0
Lost Time Adjust (s)				
Total Lost Time (s)				
Lead/Lag	Lag	Lag		Lead
Lead-Lag Optimize?	Yes	Yes		Yes
Recall Mode	None	None	C-Max	None
Act Effct Green (s)				
Actuated g/C Ratio				
v/c Ratio				
Control Delay				
Queue Delay				
Total Delay				
LOS				
Approach Delay				
Approach LOS				
Queue Length 50th (m)				
Queue Length 95th (m)				
Internal Link Dist (m)				
Turn Bay Length (m)				
Base Capacity (vph)				
Starvation Cap Reductn				
Spillback Cap Reductn				
Storage Cap Reductn				
Reduced v/c Ratio				

Intersection Summary	
Cycle Length: 100	
Actuated Cycle Length: 100	
Offset: 52 (52%), Referenced to phase 2:EBT and 6:WBTL, Start of Green	
Natural Cycle: 100	
Control Type: Actuated-Coordinated	

Lanes, Volumes, Timings  
3: Elgin & Laurier

2027 Future Total  
PM Peak Hour

Maximum v/c Ratio: 0.95	Intersection LOS: C
Intersection Signal Delay: 30.2	ICU Level of Service D
Intersection Capacity Utilization 79.1%	
Analysis Period (min) 15	
# 95th percentile volume exceeds capacity, queue may be longer.	
Queue shown is maximum after two cycles.	

Splits and Phases: 3: Elgin & Laurier

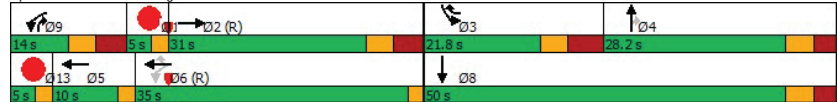

Lanes, Volumes, Timings  
4: Metcalfe & Gloucester

2027 Future Total  
PM Peak Hour

Lane Group	EBL	EBT	EBR	WBL	WBT	WBR	NBL	NBT	NBR	SBL	SBT	SBR
Lane Configurations					↑↑			↑↑↑				
Traffic Volume (vph)	0	0	0	0	209	127	114	422	0	0	0	0
Future Volume (vph)	0	0	0	0	209	127	114	422	0	0	0	0
Satd. Flow (prot)	0	0	0	0	2923	0	0	4712	0	0	0	0
Flt Permitted								0.989				
Satd. Flow (perm)	0	0	0	0	2923	0	0	4396	0	0	0	0
Satd. Flow (RTOR)					17			92				
Lane Group Flow (vph)	0	0	0	0	373	0	0	596	0	0	0	0
Turn Type					NA			Perm	NA			
Protected Phases					4			2				
Permitted Phases								2				
Detector Phase					4			2	2			
Switch Phase												
Minimum Initial (s)					10.0			10.0	10.0			
Minimum Split (s)					23.1			35.0	35.0			
Total Split (s)					30.0			45.0	45.0			
Total Split (%)					40.0%			60.0%	60.0%			
Yellow Time (s)					3.3			3.3	3.3			
All-Red Time (s)					1.8			1.7	1.7			
Lost Time Adjust (s)					0.0			0.0	0.0			
Total Lost Time (s)					5.1			5.0	5.0			
Lead/Lag												
Lead-Lag Optimize?												
Recall Mode					Max			C-Max	C-Max			
Act Effct Green (s)					24.9			35.0	40.0			
Actuated g/C Ratio					0.33			0.53	0.53			
v/c Ratio					0.38			0.25	0.25			
Control Delay					19.6			8.2	8.2			
Queue Delay					0.0			0.0	0.0			
Total Delay					19.6			8.2	8.2			
LOS					B			A	A			
Approach Delay					19.6			8.2	8.2			
Approach LOS					B			A	A			
Queue Length 50th (m)					19.8			12.7	12.7			
Queue Length 95th (m)					30.8			18.5	18.5			
Internal Link Dist (m)						34.9		48.3	35.0			51.7
Turn Bay Length (m)												
Base Capacity (vph)					981			2387	2387			
Starvation Cap Reductn					0			0	0			
Spillback Cap Reductn					0			0	0			
Storage Cap Reductn					0			0	0			
Reduced v/c Ratio					0.38			0.25	0.25			

Intersection Summary

Cycle Length: 75
Actuated Cycle Length: 75
Offset: 67 (89%), Referenced to phase 2:NBTL, Start of Green
Natural Cycle: 60
Control Type: Actuated-Coordinated

Lanes, Volumes, Timings  
4: Metcalfe & Gloucester

2027 Future Total  
PM Peak Hour

Maximum v/c Ratio: 0.38	Intersection LOS: B
Intersection Signal Delay: 12.6	ICU Level of Service A
Intersection Capacity Utilization 41.9%	
Analysis Period (min) 15	

Splits and Phases: 4: Metcalfe & Gloucester

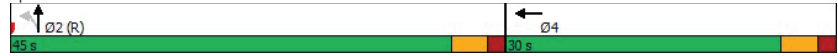

Lanes, Volumes, Timings  
5: Elgin & Nepean/City Hall

2027 Future Total  
PM Peak Hour

Lane Group	EBL	EBT	EBR	WBL	WBT	WBR	NBL	NBT	NBR	SBL	SBT	SBR
Lane Configurations		↔		↔		↔		↔		↔	↔	↔
Traffic Volume (vph)	113	1	107	31	0	23	0	320	5	7	453	0
Future Volume (vph)	113	1	107	31	0	23	0	320	5	7	453	0
Satd. Flow (prot)	0	1491	0	1658	0	1483	0	3260	0	1658	3316	0
Flt Permitted		0.975		0.605						0.522		
Satd. Flow (perm)	0	1397	0	983	0	1286	0	3260	0	751	3316	0
Satd. Flow (RTOR)		55				48		2				
Lane Group Flow (vph)	0	246	0	34	0	26	0	362	0	8	503	0
Turn Type	Perm	NA	Perm	Perm	Perm	NA	Perm	NA	Perm	NA	NA	
Protected Phases		4						2			6	
Permitted Phases	4			8		8				6		
Detector Phase	4	4		8		8		2		6	6	
Switch Phase												
Minimum Initial (s)	10.0	10.0		10.0		10.0		10.0		10.0	10.0	
Minimum Split (s)	25.1	25.1		25.1		25.1		31.4		31.4	31.4	
Total Split (s)	45.0	45.0		45.0		45.0		50.0		50.0	50.0	
Total Split (%)	45.0%	45.0%		45.0%		45.0%		50.0%		50.0%	50.0%	
Yellow Time (s)	3.3	3.3		3.3		3.3		3.3		3.3	3.3	
All-Red Time (s)	2.8	2.8		2.8		2.8		2.1		2.1	2.1	
Lost Time Adjust (s)		0.0		0.0		0.0		0.0		0.0	0.0	
Total Lost Time (s)		6.1		6.1		6.1		5.4		5.4	5.4	
Lead/Lag	Lag	Lag		Lag		Lag						
Lead-Lag Optimize?	Yes	Yes		Yes		Yes						
Recall Mode	Max	Max		Max		Max		C-Max		C-Max	C-Max	
Act Effct Green (s)		43.9		43.9		43.9		44.6		44.6	44.6	
Actuated g/C Ratio		0.44		0.44		0.44		0.45		0.45	0.45	
v/c Ratio		0.38		0.08		0.04		0.25		0.02	0.34	
Control Delay		16.5		17.1		2.0		17.7		14.1	18.1	
Queue Delay		0.0		0.0		0.0		0.0		0.0	0.0	
Total Delay		16.5		17.1		2.0		17.7		14.1	18.1	
LOS		B		B		A		B		B	B	
Approach Delay		16.5				10.6		17.7			18.0	
Approach LOS		B				B		B			B	
Queue Length 50th (m)		23.7		3.7		0.0		22.2		0.6	38.2	
Queue Length 95th (m)		42.7		9.6		2.2		31.8		m1.2	47.2	
Internal Link Dist (m)		54.5				21.0		120.5			136.3	
Turn Bay Length (m)										20.0		
Base Capacity (vph)		644		431		591		1455		334	1478	
Starvation Cap Reductn		0		0		0		0		0	0	
Spillback Cap Reductn		0		0		0		0		0	0	
Storage Cap Reductn		0		0		0		0		0	0	
Reduced v/c Ratio		0.38		0.08		0.04		0.25		0.02	0.34	

Intersection Summary

Cycle Length: 100
Actuated Cycle Length: 100
Offset: 0 (0%), Referenced to phase 2:NBT and 6:SBTL, Start of Green
Natural Cycle: 65
Control Type: Actuated-Coordinated

Lanes, Volumes, Timings  
5: Elgin & Nepean/City Hall

2027 Future Total  
PM Peak Hour

Lane Group	Ø3	Ø7
Lane Configurations		
Traffic Volume (vph)		
Future Volume (vph)		
Satd. Flow (prot)		
Flt Permitted		
Satd. Flow (perm)		
Satd. Flow (RTOR)		
Lane Group Flow (vph)		
Turn Type		
Protected Phases	3	7
Permitted Phases		
Detector Phase		
Switch Phase		
Minimum Initial (s)	1.0	1.0
Minimum Split (s)	5.0	5.0
Total Split (s)	5.0	5.0
Total Split (%)	5%	5%
Yellow Time (s)	2.0	2.0
All-Red Time (s)	0.0	0.0
Lost Time Adjust (s)		
Total Lost Time (s)		
Lead/Lag	Lead	Lead
Lead-Lag Optimize?	Yes	Yes
Recall Mode	None	None
Act Effct Green (s)		
Actuated g/C Ratio		
v/c Ratio		
Control Delay		
Queue Delay		
Total Delay		
LOS		
Approach Delay		
Approach LOS		
Queue Length 50th (m)		
Queue Length 95th (m)		
Internal Link Dist (m)		
Turn Bay Length (m)		
Base Capacity (vph)		
Starvation Cap Reductn		
Spillback Cap Reductn		
Storage Cap Reductn		
Reduced v/c Ratio		
Intersection Summary		

Lanes, Volumes, Timings  
5: Elgin & Nepean/City Hall

2027 Future Total  
PM Peak Hour

Maximum v/c Ratio: 0.38	
Intersection Signal Delay: 17.2	Intersection LOS: B
Intersection Capacity Utilization 66.6%	ICU Level of Service C
Analysis Period (min) 15	
m Volume for 95th percentile queue is metered by upstream signal.	

Splits and Phases: 5: Elgin & Nepean/City Hall



Lanes, Volumes, Timings  
6: Access & Laurier

2027 Future Total  
PM Peak Hour

Lane Group	EBT	EBR	WBL	WBT	NBL	NBR
Lane Configurations	↑			↑	↑	↑
Traffic Volume (vph)	451	12	4	482	9	3
Future Volume (vph)	451	12	4	482	9	3
Satd. Flow (prot)	1740	0	0	1745	1628	0
Flt Permitted				0.963		
Satd. Flow (perm)	1740	0	0	1745	1628	0
Lane Group Flow (vph)	514	0	0	540	13	0
Sign Control	Free			Free	Stop	
<b>Intersection Summary</b>						
Control Type: Unsignalized						
Intersection Capacity Utilization 40.1%	ICU Level of Service A					
Analysis Period (min) 15						

HCM 2010 TWSC  
6: Access & Laurier

2027 Future Total  
PM Peak Hour

<b>Intersection</b>						
Int Delay, s/veh	0.3					
Movement	EBT	EBR	WBL	WBT	NBL	NBR
Lane Configurations	↑			↑	↑	↑
Traffic Vol, veh/h	451	12	4	482	9	3
Future Vol, veh/h	451	12	4	482	9	3
Conflicting Peds, #/hr	0	0	0	0	0	0
Sign Control	Free	Free	Free	Free	Stop	Stop
RT Channelized	-	None	-	None	-	None
Storage Length	-	-	-	-	0	-
Veh in Median Storage, #	0	-	-	0	0	-
Grade, %	0	-	-	0	0	-
Peak Hour Factor	90	90	90	90	90	90
Heavy Vehicles, %	2	2	2	2	2	2
Mvmt Flow	501	13	4	536	10	3

Major/Minor	Major1	Major2	Minor1
Conflicting Flow All	0	0	514
Stage 1	-	-	508
Stage 2	-	-	544
Critical Hdwy	-	4.12	6.42
Critical Hdwy Stg 1	-	-	5.42
Critical Hdwy Stg 2	-	-	5.42
Follow-up Hdwy	-	2.218	3.518
Pot Cap-1 Maneuver	-	1052	251
Stage 1	-	-	604
Stage 2	-	-	582
Platoon blocked, %	-	-	-
Mov Cap-1 Maneuver	-	1052	250
Mov Cap-2 Maneuver	-	-	250
Stage 1	-	-	604
Stage 2	-	-	579

Approach	EB	WB	NB
HCM Control Delay, s	0	0.1	18
HCM LOS			C

Minor Lane/Major Mvmt	NBLn1	EBT	EBR	WBL	WBT
Capacity (veh/h)	290	-	-	1052	-
HCM Lane V/C Ratio	0.046	-	-	0.004	-
HCM Control Delay (s)	18	-	-	8.4	-
HCM Lane LOS	C	-	-	A	-
HCM 95th %tile Q(veh)	0.1	-	-	0	-



# Appendix J

Synchro Intersection Worksheets – 2032 Future Total Conditions

Lanes, Volumes, Timings  
1: O'Connor & Laurier

2032 Future Total  
AM Peak Hour

Lane Group	EBL	EBT	EBR	WBL	WBT	WBR	NBL	NBT	NBR	SBL	SBT	SBR
Lane Configurations		↔		↔	↔						↔↔↔	
Traffic Volume (vph)	0	220	122	136	341	0	0	0	0	85	451	67
Future Volume (vph)	0	220	122	136	341	0	0	0	0	85	451	67
Satd. Flow (prot)	0	1435	0	1642	1712	0	0	0	0	0	4174	0
Flt Permitted				0.377							0.993	
Satd. Flow (perm)	0	1435	0	652	1712	0	0	0	0	0	3784	0
Satd. Flow (RTOR)												
Lane Group Flow (vph)	0	342	0	136	341	0	0	0	0	0	603	0
Turn Type		NA		pm+pt	NA					Perm	NA	
Protected Phases		2		9	6							4
Permitted Phases				6							4	
Detector Phase		2		9	6						4	4
Switch Phase												
Minimum Initial (s)		10.0		5.0	10.0					10.0	10.0	
Minimum Split (s)		23.9		10.8	21.9					22.5	22.5	
Total Split (s)		29.0		11.0	45.0					25.0	25.0	
Total Split (%)		38.7%		14.7%	60.0%					33.3%	33.3%	
Yellow Time (s)		3.3		3.3	3.3					3.3	3.3	
All-Red Time (s)		2.6		2.5	2.6					2.6	2.6	
Lost Time Adjust (s)		0.0		0.0	0.0						0.0	
Total Lost Time (s)		5.9		5.8	5.9						5.9	
Lead/Lag				Lead						Lag	Lag	
Lead-Lag Optimize?				Yes						Yes	Yes	
Recall Mode		C-Max		Max	C-Max					Max	Max	
Act Effct Green (s)		28.1		39.2	39.1						24.1	
Actuated g/C Ratio		0.37		0.52	0.52						0.32	
v/c Ratio		0.64		0.33	0.38						0.50	
Control Delay		25.8		7.1	6.7						22.3	
Queue Delay		0.0		0.0	0.0						0.0	
Total Delay		25.8		7.1	6.7						22.3	
LOS		C		A	A						C	
Approach Delay		25.8			6.8						22.3	
Approach LOS		C			A						C	
Queue Length 50th (m)		38.8		5.2	13.4						24.9	
Queue Length 95th (m)		65.9		m9.3	19.8						34.9	
Internal Link Dist (m)		71.8			158.7			39.2			62.3	
Turn Bay Length (m)												
Base Capacity (vph)		537		409	892						1215	
Starvation Cap Reductn		0		0	0						0	
Spillback Cap Reductn		0		0	0						0	
Storage Cap Reductn		0		0	0						0	
Reduced v/c Ratio		0.64		0.33	0.38						0.50	

Intersection Summary	
Cycle Length: 75	
Actuated Cycle Length: 75	
Offset: 63 (84%), Referenced to phase 2:EBT and 6:WBTL, Start of Green	
Natural Cycle: 70	
Control Type: Actuated-Coordinated	

Lanes, Volumes, Timings  
1: O'Connor & Laurier

2032 Future Total  
AM Peak Hour

Lane Group	Ø1	Ø3
Lane Configurations		
Traffic Volume (vph)		
Future Volume (vph)		
Satd. Flow (prot)		
Flt Permitted		
Satd. Flow (perm)		
Satd. Flow (RTOR)		
Lane Group Flow (vph)		
Turn Type		
Protected Phases	1	3
Permitted Phases		
Detector Phase		
Switch Phase		
Minimum Initial (s)	1.0	1.0
Minimum Split (s)	5.0	5.0
Total Split (s)	5.0	5.0
Total Split (%)	7%	7%
Yellow Time (s)	2.0	2.0
All-Red Time (s)	0.0	0.0
Lost Time Adjust (s)		
Total Lost Time (s)		
Lead/Lag	Lag	Lead
Lead-Lag Optimize?	Yes	Yes
Recall Mode	None	None
Act Effct Green (s)		
Actuated g/C Ratio		
v/c Ratio		
Control Delay		
Queue Delay		
Total Delay		
LOS		
Approach Delay		
Approach LOS		
Queue Length 50th (m)		
Queue Length 95th (m)		
Internal Link Dist (m)		
Turn Bay Length (m)		
Base Capacity (vph)		
Starvation Cap Reductn		
Spillback Cap Reductn		
Storage Cap Reductn		
Reduced v/c Ratio		

Intersection Summary	
Cycle Length: 75	
Actuated Cycle Length: 75	
Offset: 63 (84%), Referenced to phase 2:EBT and 6:WBTL, Start of Green	
Natural Cycle: 70	
Control Type: Actuated-Coordinated	

Lanes, Volumes, Timings  
1: O'Connor & Laurier

2032 Future Total  
AM Peak Hour

Maximum v/c Ratio: 0.64	Intersection LOS: B
Intersection Signal Delay: 17.9	ICU Level of Service B
Intersection Capacity Utilization 61.6%	
Analysis Period (min) 15	

m Volume for 95th percentile queue is metered by upstream signal.

Splits and Phases: 1: O'Connor & Laurier



Lanes, Volumes, Timings  
2: Metcalfe & Laurier

2032 Future Total  
AM Peak Hour

Lane Group	EBL	EBT	EBR	WBL	WBT	WBR	NBL	NBT	NBR	SBL	SBT	SBR
Lane Configurations		↕			↕			↕				
Traffic Volume (vph)	22	293	0	0	401	258	96	704	75	0	0	0
Future Volume (vph)	22	293	0	0	401	258	96	704	75	0	0	0
Satd. Flow (prot)	0	1736	0	0	2518	0	0	4353	0	0	0	0
Flt Permitted		0.937						0.995				
Satd. Flow (perm)	0	1616	0	0	2518	0	0	4157	0	0	0	0
Satd. Flow (RTOR)												
Lane Group Flow (vph)	0	315	0	0	659	0	0	875	0	0	0	0
Turn Type	Perm	NA			NA		Perm	NA				
Protected Phases		2			6			4				
Permitted Phases	2							4				
Detector Phase	2	2			6			4	4			
Switch Phase												
Minimum Initial (s)	10.0	10.0			10.0			10.0	10.0			
Minimum Split (s)	37.0	37.0			37.0			33.0	33.0			
Total Split (s)	37.0	37.0			37.0			33.0	33.0			
Total Split (%)	49.3%	49.3%			49.3%			44.0%	44.0%			
Yellow Time (s)	3.3	3.3			3.3			3.3	3.3			
All-Red Time (s)	2.4	2.4			2.4			2.2	2.2			
Lost Time Adjust (s)		0.0			0.0			0.0	0.0			
Total Lost Time (s)		5.7			5.7			5.5	5.5			
Lead/Lag	Lag	Lag			Lag							
Lead-Lag Optimize?	Yes	Yes			Yes							
Recall Mode	C-Max	C-Max			C-Max			Max	Max			
Act Effct Green (s)		36.3			36.3				27.5			
Actuated g/C Ratio		0.48			0.48				0.37			
v/c Ratio		0.40			0.54				0.57			
Control Delay		19.3			15.6				15.3			
Queue Delay		0.0			0.0				0.4			
Total Delay		19.3			15.6				15.7			
LOS		B			B				B			
Approach Delay		19.3			15.6				15.7			
Approach LOS		B			B				B			
Queue Length 50th (m)		32.0			32.4				36.9			
Queue Length 95th (m)		57.1			47.2				49.0			
Internal Link Dist (m)		158.7			93.1				51.7		65.1	
Turn Bay Length (m)												
Base Capacity (vph)		782			1218				1524			
Starvation Cap Reductn		0			0				237			
Spillback Cap Reductn		0			0				0			
Storage Cap Reductn		0			0				0			
Reduced v/c Ratio		0.40			0.54				0.68			

Intersection Summary

Cycle Length: 75
Actuated Cycle Length: 75
Offset: 48 (64%), Referenced to phase 2:EBTL and 6:WBT, Start of Green
Natural Cycle: 75
Control Type: Actuated-Coordinated

Lanes, Volumes, Timings  
2: Metcalfe & Laurier

2032 Future Total  
AM Peak Hour

Lane Group	Ø1	Ø5
Lane Configurations		
Traffic Volume (vph)		
Future Volume (vph)		
Satd. Flow (prot)		
Flt Permitted		
Satd. Flow (perm)		
Satd. Flow (RTOR)		
Lane Group Flow (vph)		
Turn Type		
Protected Phases	1	5
Permitted Phases		
Detector Phase		
Switch Phase		
Minimum Initial (s)	1.0	1.0
Minimum Split (s)	5.0	5.0
Total Split (s)	5.0	5.0
Total Split (%)	7%	7%
Yellow Time (s)	2.0	2.0
All-Red Time (s)	0.0	0.0
Lost Time Adjust (s)		
Total Lost Time (s)		
Lead/Lag	Lead	Lead
Lead-Lag Optimize?	Yes	Yes
Recall Mode	None	None
Act Effct Green (s)		
Actuated g/C Ratio		
v/c Ratio		
Control Delay		
Queue Delay		
Total Delay		
LOS		
Approach Delay		
Approach LOS		
Queue Length 50th (m)		
Queue Length 95th (m)		
Internal Link Dist (m)		
Turn Bay Length (m)		
Base Capacity (vph)		
Starvation Cap Reductn		
Spillback Cap Reductn		
Storage Cap Reductn		
Reduced v/c Ratio		
Intersection Summary		

Lanes, Volumes, Timings  
2: Metcalfe & Laurier

2032 Future Total  
AM Peak Hour

Maximum v/c Ratio: 0.57	
Intersection Signal Delay: 16.3	Intersection LOS: B
Intersection Capacity Utilization 66.1%	ICU Level of Service C
Analysis Period (min) 15	



Lanes, Volumes, Timings  
3: Elgin & Laurier/City Hall

2032 Future Total  
AM Peak Hour

Lane Group	EBL	EBT	EBR	WBL	WBT	WBR	NBL	NBT	NBR	SBL	SBT	SBR
Lane Configurations		↕		↕	↕	↕		↕	↕	↕	↕	
Traffic Volume (vph)	0	288	59	209	498	538	0	213	59	361	376	171
Future Volume (vph)	0	288	59	209	498	538	0	213	59	361	376	171
Satd. Flow (prot)	0	3037	0	1658	1745	1483	0	3316	1483	3154	2431	0
Flt Permitted				0.527						0.950		
Satd. Flow (perm)	0	3037	0	765	1745	920	0	3316	680	1878	2431	0
Satd. Flow (RTOR)						238			149		92	
Lane Group Flow (vph)	0	347	0	209	498	538	0	213	59	361	547	0
Turn Type		NA		custom	NA	custom		NA	pm+ov	Prot	NA	
Protected Phases		2		9	5	6		3	4	9	3	8
Permitted Phases				6		6			4			
Detector Phase		2		9	5	6		3	4	9	3	8
Switch Phase												
Minimum Initial (s)		5.0		5.0		10.0		10.0	5.0	10.0		10.0
Minimum Split (s)		30.0		12.0		20.7		28.2	12.0	20.7		28.2
Total Split (s)		31.0		15.0		20.8		28.2	15.0	20.8		49.0
Total Split (%)		31.0%		15.0%		20.8%		28.2%	15.0%	20.8%		49.0%
Yellow Time (s)		3.3		3.3		3.3		3.3	3.3	3.3		3.3
All-Red Time (s)		3.7		3.7		4.4		2.9	3.7	4.4		2.9
Lost Time Adjust (s)		0.0		0.0		0.0		0.0	0.0	0.0		0.0
Total Lost Time (s)		7.0		7.0		7.7		6.2	7.0	7.7		6.2
Lead/Lag				Lead		Lead		Lag	Lead		Lead	
Lead-Lag Optimize?				Yes		Yes		Yes	Yes		Yes	
Recall Mode		C-Max		Max		None		Max	Max		None	Max
Act Effct Green (s)		29.0		37.0		49.0		22.0	29.2		13.1	42.8
Actuated g/C Ratio		0.29		0.37		0.49		0.22	0.29		0.13	0.43
v/c Ratio		0.39		0.59		0.58		0.29	0.16		0.87	0.50
Control Delay		30.1		27.3		21.7		33.8	0.9		65.4	18.9
Queue Delay		0.0		0.0		0.0		0.0	0.0		0.0	0.0
Total Delay		30.1		27.3		21.7		33.8	0.9		65.4	18.9
LOS		C		C		C		C	A		E	B
Approach Delay		30.1				28.6		26.7				37.4
Approach LOS		C				C		C				D
Queue Length 50th (m)		28.2		25.3		66.2		39.9		18.2	0.0	35.8
Queue Length 95th (m)		41.0		41.4		97.5		#89.7		28.4	0.0	#60.1
Internal Link Dist (m)		55.2				106.8				136.3		
Turn Bay Length (m)									90.0		85.0	
Base Capacity (vph)		880		354		855		594		729	368	413
Starvation Cap Reductn		0		0		0		0		0	0	0
Spillback Cap Reductn		0		0		0		0		0	0	0
Storage Cap Reductn		0		0		0		0		0	0	0
Reduced v/c Ratio		0.39		0.59		0.58		0.91		0.29	0.16	0.87

Intersection Summary

Cycle Length: 100
Actuated Cycle Length: 100
Offset: 64 (64%), Referenced to phase 2:EBT and 6:WBTL, Start of Green
Natural Cycle: 100
Control Type: Actuated-Coordinated

Lanes, Volumes, Timings  
3: Elgin & Laurier/City Hall

2032 Future Total  
AM Peak Hour

Lane Group	Ø1	Ø5	Ø6	Ø13
Lane Configurations				
Traffic Volume (vph)				
Future Volume (vph)				
Satd. Flow (prot)				
Flt Permitted				
Satd. Flow (perm)				
Satd. Flow (RTOR)				
Lane Group Flow (vph)				
Turn Type				
Protected Phases	1	5	6	13
Permitted Phases				
Detector Phase				
Switch Phase				
Minimum Initial (s)	1.0	1.0	5.0	1.0
Minimum Split (s)	5.0	7.0	25.0	5.0
Total Split (s)	5.0	10.0	36.0	5.0
Total Split (%)	5%	10%	36%	5%
Yellow Time (s)	2.0	2.0	2.0	2.0
All-Red Time (s)	0.0	0.0	0.0	0.0
Lost Time Adjust (s)				
Total Lost Time (s)				
Lead/Lag	Lag	Lag		Lead
Lead-Lag Optimize?	Yes	Yes		Yes
Recall Mode	None	None	C-Max	None
Act Effct Green (s)				
Actuated g/C Ratio				
v/c Ratio				
Control Delay				
Queue Delay				
Total Delay				
LOS				
Approach Delay				
Approach LOS				
Queue Length 50th (m)				
Queue Length 95th (m)				
Internal Link Dist (m)				
Turn Bay Length (m)				
Base Capacity (vph)				
Starvation Cap Reductn				
Spillback Cap Reductn				
Storage Cap Reductn				
Reduced v/c Ratio				

Intersection Summary

Cycle Length: 100
Actuated Cycle Length: 100
Offset: 64 (64%), Referenced to phase 2:EBT and 6:WBTL, Start of Green
Natural Cycle: 100
Control Type: Actuated-Coordinated

Lanes, Volumes, Timings  
3: Elgin & Laurier/City Hall

2032 Future Total  
AM Peak Hour

Maximum v/c Ratio: 0.91	Intersection LOS: C
Intersection Signal Delay: 31.5	ICU Level of Service E
Intersection Capacity Utilization 83.8%	
Analysis Period (min) 15	
# 95th percentile volume exceeds capacity, queue may be longer.	
Queue shown is maximum after two cycles.	

Splits and Phases: 3: Elgin & Laurier/City Hall

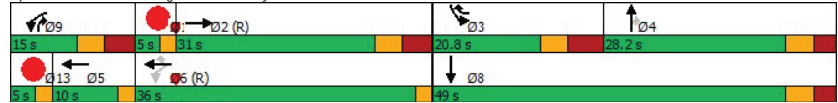

Lanes, Volumes, Timings  
4: Metcalfe & Gloucester

2032 Future Total  
AM Peak Hour

Lane Group	EBL	EBT	EBR	WBL	WBT	WBR	NBL	NBT	NBR	SBL	SBT	SBR
Lane Configurations					↑↑			↑↑↑				
Traffic Volume (vph)	0	0	0	0	164	74	247	811	0	0	0	0
Future Volume (vph)	0	0	0	0	164	74	247	811	0	0	0	0
Satd. Flow (prot)	0	0	0	0	2845	0	0	4696	0	0	0	0
Flt Permitted								0.988				
Satd. Flow (perm)	0	0	0	0	2845	0	0	4330	0	0	0	0
Satd. Flow (RTOR)					26			89				
Lane Group Flow (vph)	0	0	0	0	238	0	0	1058	0	0	0	0
Turn Type					NA			Perm	NA			
Protected Phases					4			2				
Permitted Phases								2				
Detector Phase					4			2	2			
Switch Phase												
Minimum Initial (s)					10.0			10.0	10.0			
Minimum Split (s)					23.1			35.0	35.0			
Total Split (s)					25.0			50.0	50.0			
Total Split (%)					33.3%			66.7%	66.7%			
Yellow Time (s)					3.3			3.3	3.3			
All-Red Time (s)					1.8			1.7	1.7			
Lost Time Adjust (s)					0.0			0.0	0.0			
Total Lost Time (s)					5.1			5.0	5.0			
Lead/Lag												
Lead-Lag Optimize?												
Recall Mode					Max			C-Max	C-Max			
Act Effct Green (s)					19.9			35.0	45.0			
Actuated g/C Ratio					0.27			0.60	0.60			
v/c Ratio					0.31			0.40	0.40			
Control Delay					20.8			7.7	7.7			
Queue Delay					0.0			0.0	0.0			
Total Delay					20.8			7.7	7.7			
LOS					C			A	A			
Approach Delay					20.8			7.7	7.7			
Approach LOS					C			A	A			
Queue Length 50th (m)					12.4			23.2	23.2			
Queue Length 95th (m)					21.5			30.9	30.9			
Internal Link Dist (m)						34.9		48.3	35.0			51.7
Turn Bay Length (m)												
Base Capacity (vph)					773			2633	2633			
Starvation Cap Reductn					0			0	0			
Spillback Cap Reductn					0			146	146			
Storage Cap Reductn					0			0	0			
Reduced v/c Ratio					0.31			0.43	0.43			

Intersection Summary

Cycle Length: 75
Actuated Cycle Length: 75
Offset: 73 (97%), Referenced to phase 2:NBTL, Start of Green
Natural Cycle: 60
Control Type: Actuated-Coordinated

Lanes, Volumes, Timings  
4: Metcalfe & Gloucester

2032 Future Total  
AM Peak Hour

Maximum v/c Ratio: 0.40	Intersection LOS: B
Intersection Signal Delay: 10.1	ICU Level of Service A
Intersection Capacity Utilization 44.1%	
Analysis Period (min) 15	



Lanes, Volumes, Timings  
5: Elgin & Nepean/City Hall

2032 Future Total  
AM Peak Hour

Lane Group	EBL	EBT	EBR	WBL	WBT	WBR	NBL	NBT	NBR	SBL	SBT	SBR
Lane Configurations		↔		↔		↔		↔		↔	↔	↔
Traffic Volume (vph)	31	7	31	1	0	9	0	281	43	17	338	0
Future Volume (vph)	31	7	31	1	0	9	0	281	43	17	338	0
Satd. Flow (prot)	0	1506	0	1658	0	1483	0	3079	0	1658	3252	0
Flt Permitted		0.978		0.712						0.556		
Satd. Flow (perm)	0	1427	0	1188	0	1294	0	3079	0	850	3252	0
Satd. Flow (RTOR)		31				53		32				
Lane Group Flow (vph)	0	69	0	1	0	9	0	324	0	17	338	0
Turn Type	Perm	NA		Perm		Perm		NA		Perm	NA	
Protected Phases		4						2				6
Permitted Phases	4			8		8				6		
Detector Phase	4	4		8		8		2		6		6
Switch Phase												
Minimum Initial (s)	10.0	10.0		10.0		10.0		10.0		10.0		10.0
Minimum Split (s)	25.1	25.1		25.1		25.1		31.4		31.4		31.4
Total Split (s)	27.0	27.0		27.0		27.0		58.0		58.0		58.0
Total Split (%)	30.0%	30.0%		30.0%		30.0%		64.4%		64.4%		64.4%
Yellow Time (s)	3.3	3.3		3.3		3.3		3.3		3.3		3.3
All-Red Time (s)	2.8	2.8		2.8		2.8		2.1		2.1		2.1
Lost Time Adjust (s)		0.0		0.0		0.0		0.0		0.0		0.0
Total Lost Time (s)		6.1		6.1		6.1		5.4		5.4		5.4
Lead/Lag	Lag	Lag		Lag		Lag						
Lead-Lag Optimize?	Yes	Yes		Yes		Yes						
Recall Mode	Max	Max		Max		Max		C-Max		C-Max		C-Max
Act Effct Green (s)		25.9		25.9		25.9		52.6		52.6		52.6
Actuated g/C Ratio		0.29		0.29		0.29		0.58		0.58		0.58
v/c Ratio		0.16		0.00		0.02		0.18		0.03		0.18
Control Delay		16.1		23.0		0.1		8.1		8.2		9.0
Queue Delay		0.0		0.0		0.0		0.0		0.0		0.0
Total Delay		16.1		23.0		0.1		8.1		8.2		9.0
LOS		B		C		A		A		A		A
Approach Delay		16.1				2.4		8.1				8.9
Approach LOS		B				A		A				A
Queue Length 50th (m)		4.8		0.1		0.0		11.2		1.2		13.1
Queue Length 95th (m)		14.5		1.3		0.0		17.3		3.8		19.4
Internal Link Dist (m)		54.5				21.0		120.5				136.3
Turn Bay Length (m)										20.0		
Base Capacity (vph)		432		341		410		1812		496		1900
Starvation Cap Reductn		0		0		0		0		0		0
Spillback Cap Reductn		0		0		0		0		0		0
Storage Cap Reductn		0		0		0		0		0		0
Reduced v/c Ratio		0.16		0.00		0.02		0.18		0.03		0.18

<b>Intersection Summary</b>												
Cycle Length: 90												
Actuated Cycle Length: 90												
Offset: 0 (0%), Referenced to phase 2:NBT and 6:SBTL, Start of Green												
Natural Cycle: 65												
Control Type: Actuated-Coordinated												

Lanes, Volumes, Timings  
5: Elgin & Nepean/City Hall

2032 Future Total  
AM Peak Hour

Lane Group	Ø3	Ø7
Lane Configurations		
Traffic Volume (vph)		
Future Volume (vph)		
Satd. Flow (prot)		
Flt Permitted		
Satd. Flow (perm)		
Satd. Flow (RTOR)		
Lane Group Flow (vph)		
Turn Type		
Protected Phases	3	7
Permitted Phases		
Detector Phase		
Switch Phase		
Minimum Initial (s)	1.0	1.0
Minimum Split (s)	5.0	5.0
Total Split (s)	5.0	5.0
Total Split (%)	6%	6%
Yellow Time (s)	2.0	2.0
All-Red Time (s)	0.0	0.0
Lost Time Adjust (s)		
Total Lost Time (s)		
Lead/Lag	Lead	Lead
Lead-Lag Optimize?	Yes	Yes
Recall Mode	None	None
Act Effct Green (s)		
Actuated g/C Ratio		
v/c Ratio		
Control Delay		
Queue Delay		
Total Delay		
LOS		
Approach Delay		
Approach LOS		
Queue Length 50th (m)		
Queue Length 95th (m)		
Internal Link Dist (m)		
Turn Bay Length (m)		
Base Capacity (vph)		
Starvation Cap Reductn		
Spillback Cap Reductn		
Storage Cap Reductn		
Reduced v/c Ratio		
Intersection Summary		

Lanes, Volumes, Timings  
5: Elgin & Nepean/City Hall

2032 Future Total  
AM Peak Hour

Maximum v/c Ratio: 0.18	
Intersection Signal Delay: 9.1	Intersection LOS: A
Intersection Capacity Utilization 66.3%	ICU Level of Service C
Analysis Period (min) 15	

Splits and Phases: 5: Elgin & Nepean/City Hall

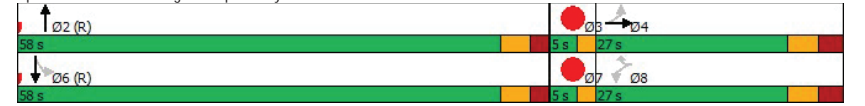



Lanes, Volumes, Timings  
6: Access & Laurier

2032 Future Total  
AM Peak Hour

Lane Group	EBT	EBR	WBL	WBT	NBL	NBR
Lane Configurations	↔		↔		↔	
Traffic Volume (vph)	338	6	3	711	13	5
Future Volume (vph)	338	6	3	711	13	5
Satd. Flow (prot)	1742	0	0	1745	1620	0
Flt Permitted				0.965		
Satd. Flow (perm)	1742	0	0	1745	1620	0
Lane Group Flow (vph)	344	0	0	714	18	0
Sign Control	Free		Free		Stop	
<b>Intersection Summary</b>						
Control Type: Unsignalized						
Intersection Capacity Utilization 52.0%						
ICU Level of Service A						
Analysis Period (min) 15						

HCM 2010 TWSC  
6: Access & Laurier

2032 Future Total  
AM Peak Hour

<b>Intersection</b>						
Int Delay, s/veh	0.3					
Movement	EBT	EBR	WBL	WBT	NBL	NBR
Lane Configurations	↔		↔		↔	
Traffic Vol, veh/h	338	6	3	711	13	5
Future Vol, veh/h	338	6	3	711	13	5
Conflicting Peds, #/hr	0	0	0	0	0	0
Sign Control	Free	Free	Free	Free	Stop	Stop
RT Channelized	-	None	-	None	-	None
Storage Length	-	-	-	-	0	-
Veh in Median Storage, #	0	-	-	0	0	-
Grade, %	0	-	-	0	0	-
Peak Hour Factor	100	100	100	100	100	100
Heavy Vehicles, %	2	2	2	2	2	2
Mvmt Flow	338	6	3	711	13	5

Major/Minor	Major1	Major2	Minor1
Conflicting Flow All	0	0	344
Stage 1	-	-	341
Stage 2	-	-	717
Critical Hdwy	-	4.12	6.42
Critical Hdwy Stg 1	-	-	5.42
Critical Hdwy Stg 2	-	-	5.42
Follow-up Hdwy	-	2.218	3.318
Pot Cap-1 Maneuver	-	1215	249
Stage 1	-	-	720
Stage 2	-	-	484
Platoon blocked, %	-	-	-
Mov Cap-1 Maneuver	-	1215	248
Mov Cap-2 Maneuver	-	-	248
Stage 1	-	-	720
Stage 2	-	-	482

Approach	EB	WB	NB
HCM Control Delay, s	0	0	17.7
HCM LOS			C

Minor Lane/Major Mvmt	NBLn1	EBT	EBR	WBL	WBT
Capacity (veh/h)	302	-	-	1215	-
HCM Lane V/C Ratio	0.06	-	-	0.002	-
HCM Control Delay (s)	17.7	-	-	8	0
HCM Lane LOS	C	-	-	A	A
HCM 95th %tile Q(veh)	0.2	-	-	0	-

Lanes, Volumes, Timings  
1: O'Connor & Laurier

2032 Future Total  
PM Peak Hour

Lane Group	EBL	EBT	EBR	WBL	WBT	WBR	NBL	NBT	NBR	SBL	SBT	SBR
Lane Configurations		↔	↔	↔	↔	↔	↔	↔	↔	↔	↔	↔
Traffic Volume (vph)	0	214	95	181	277	0	0	0	0	51	544	44
Future Volume (vph)	0	214	95	181	277	0	0	0	0	51	544	44
Satd. Flow (prot)	0	1480	0	1642	1745	0	0	0	0	0	4480	0
Flt Permitted				0.375							0.996	
Satd. Flow (perm)	0	1480	0	648	1745	0	0	0	0	0	4249	0
Satd. Flow (RTOR)												
Lane Group Flow (vph)	0	344	0	201	308	0	0	0	0	0	710	0
Turn Type		NA		pm+pt	NA					Perm	NA	
Protected Phases		2		9	6							4
Permitted Phases				6							4	
Detector Phase		2		9	6						4	4
Switch Phase												
Minimum Initial (s)		10.0		5.0	10.0					10.0	10.0	
Minimum Split (s)		23.9		10.8	21.9					22.5	22.5	
Total Split (s)		29.0		11.0	45.0					25.0	25.0	
Total Split (%)		38.7%		14.7%	60.0%					33.3%	33.3%	
Yellow Time (s)		3.3		3.3	3.3					3.3	3.3	
All-Red Time (s)		2.6		2.5	2.6					2.6	2.6	
Lost Time Adjust (s)		0.0		0.0	0.0						0.0	
Total Lost Time (s)		5.9		5.8	5.9						5.9	
Lead/Lag				Lead						Lag	Lag	
Lead-Lag Optimize?				Yes						Yes	Yes	
Recall Mode		C-Max		Max	C-Max					Max	Max	
Act Effct Green (s)		28.1		39.2	39.1						24.1	
Actuated g/C Ratio		0.37		0.52	0.52						0.32	
v/c Ratio		0.62		0.49	0.34						0.52	
Control Delay		25.1		23.0	16.5						22.4	
Queue Delay		0.0		0.0	0.0						0.0	
Total Delay		25.1		23.0	16.5						22.4	
LOS		C		C	B						C	
Approach Delay		25.1			19.0						22.4	
Approach LOS		C			B						C	
Queue Length 50th (m)		38.8		19.2	26.3						29.6	
Queue Length 95th (m)		65.3		38.1	47.6						40.4	
Internal Link Dist (m)		71.8			158.7			39.2			62.3	
Turn Bay Length (m)												
Base Capacity (vph)		554		407	909						1365	
Starvation Cap Reductn		0		0	0						0	
Spillback Cap Reductn		0		0	0						0	
Storage Cap Reductn		0		0	0						0	
Reduced v/c Ratio		0.62		0.49	0.34						0.52	

Intersection Summary	
Cycle Length: 75	
Actuated Cycle Length: 75	
Offset: 22 (29%), Referenced to phase 2:EBT and 6:WBTL, Start of Green	
Natural Cycle: 70	
Control Type: Actuated-Coordinated	

Lanes, Volumes, Timings  
1: O'Connor & Laurier

2032 Future Total  
PM Peak Hour

Lane Group	Ø1	Ø3
Lane Configurations		
Traffic Volume (vph)		
Future Volume (vph)		
Satd. Flow (prot)		
Flt Permitted		
Satd. Flow (perm)		
Satd. Flow (RTOR)		
Lane Group Flow (vph)		
Turn Type		
Protected Phases	1	3
Permitted Phases		
Detector Phase		
Switch Phase		
Minimum Initial (s)	1.0	1.0
Minimum Split (s)	5.0	5.0
Total Split (s)	5.0	5.0
Total Split (%)	7%	7%
Yellow Time (s)	2.0	2.0
All-Red Time (s)	0.0	0.0
Lost Time Adjust (s)		
Total Lost Time (s)		
Lead/Lag	Lag	Lead
Lead-Lag Optimize?	Yes	Yes
Recall Mode	None	None
Act Effct Green (s)		
Actuated g/C Ratio		
v/c Ratio		
Control Delay		
Queue Delay		
Total Delay		
LOS		
Approach Delay		
Approach LOS		
Queue Length 50th (m)		
Queue Length 95th (m)		
Internal Link Dist (m)		
Turn Bay Length (m)		
Base Capacity (vph)		
Starvation Cap Reductn		
Spillback Cap Reductn		
Storage Cap Reductn		
Reduced v/c Ratio		

Intersection Summary	
Cycle Length: 75	
Actuated Cycle Length: 75	
Offset: 22 (29%), Referenced to phase 2:EBT and 6:WBTL, Start of Green	
Natural Cycle: 70	
Control Type: Actuated-Coordinated	

Lanes, Volumes, Timings  
1: O'Connor & Laurier

2032 Future Total  
PM Peak Hour

Maximum v/c Ratio: 0.62	Intersection LOS: C
Intersection Signal Delay: 21.9	ICU Level of Service B
Intersection Capacity Utilization 62.0%	
Analysis Period (min) 15	

Splits and Phases: 1: O'Connor & Laurier

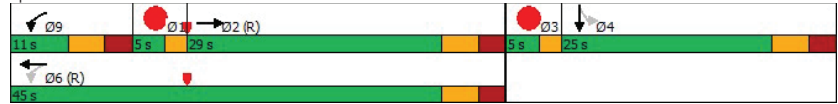

Lanes, Volumes, Timings  
2: Metcalfe & Laurier

2032 Future Total  
PM Peak Hour

Lane Group	EBL	EBT	EBR	WBL	WBT	WBR	NBL	NBT	NBR	SBL	SBT	SBR
Lane Configurations		↕			↕			↕↕↕				
Traffic Volume (vph)	10	255	0	0	399	167	33	415	128	0	0	0
Future Volume (vph)	10	255	0	0	399	167	33	415	128	0	0	0
Satd. Flow (prot)	0	1742	0	0	2815	0	0	3773	0	0	0	0
Flt Permitted		0.974			0.997							
Satd. Flow (perm)	0	1692	0	0	2815	0	0	3693	0	0	0	0
Satd. Flow (RTOR)												
Lane Group Flow (vph)	0	294	0	0	629	0	0	640	0	0	0	0
Turn Type	Perm	NA			NA		Perm	NA				
Protected Phases		2			6			4				
Permitted Phases	2						4					
Detector Phase	2	2			6		4	4				
Switch Phase												
Minimum Initial (s)	10.0	10.0			10.0		10.0	10.0				
Minimum Split (s)	37.0	37.0			37.0		19.5	19.5				
Total Split (s)	40.0	40.0			40.0		30.0	30.0				
Total Split (%)	53.3%	53.3%			53.3%		40.0%	40.0%				
Yellow Time (s)	3.3	3.3			3.3		3.3	3.3				
All-Red Time (s)	2.4	2.4			2.4		2.2	2.2				
Lost Time Adjust (s)		0.0			0.0			0.0				
Total Lost Time (s)		5.7			5.7			5.5				
Lead/Lag	Lag	Lag			Lag							
Lead-Lag Optimize?	Yes	Yes			Yes							
Recall Mode	C-Max	C-Max			C-Max		Max	Max				
Act Effct Green (s)		39.3			39.3			24.5				
Actuated g/C Ratio		0.52			0.52			0.33				
v/c Ratio		0.33			0.43			0.53				
Control Delay		6.5			12.1			17.8				
Queue Delay		0.0			0.0			0.3				
Total Delay		6.5			12.1			18.1				
LOS		A			B			B				
Approach Delay		6.5			12.1			18.1				
Approach LOS		A			B			B				
Queue Length 50th (m)		8.9			26.7			17.0				
Queue Length 95th (m)		13.4			38.4			21.7				
Internal Link Dist (m)		158.7			97.3			51.7			65.1	
Turn Bay Length (m)												
Base Capacity (vph)		886			1475			1206				
Starvation Cap Reductn		0			0			174				
Spillback Cap Reductn		0			0			0				
Storage Cap Reductn		0			0			0				
Reduced v/c Ratio		0.33			0.43			0.62				

Intersection Summary

Cycle Length: 75
Actuated Cycle Length: 75
Offset: 30 (40%), Referenced to phase 2:EBTL and 6:WBT, Start of Green
Natural Cycle: 65
Control Type: Actuated-Coordinated

Lanes, Volumes, Timings  
2: Metcalfe & Laurier

2032 Future Total  
PM Peak Hour

Lane Group	Ø1	Ø5
Lane Configurations		
Traffic Volume (vph)		
Future Volume (vph)		
Satd. Flow (prot)		
Flt Permitted		
Satd. Flow (perm)		
Satd. Flow (RTOR)		
Lane Group Flow (vph)		
Turn Type		
Protected Phases	1	5
Permitted Phases		
Detector Phase		
Switch Phase		
Minimum Initial (s)	1.0	1.0
Minimum Split (s)	5.0	5.0
Total Split (s)	5.0	5.0
Total Split (%)	7%	7%
Yellow Time (s)	2.0	2.0
All-Red Time (s)	0.0	0.0
Lost Time Adjust (s)		
Total Lost Time (s)		
Lead/Lag	Lead	Lead
Lead-Lag Optimize?	Yes	Yes
Recall Mode	None	None
Act Effct Green (s)		
Actuated g/C Ratio		
v/c Ratio		
Control Delay		
Queue Delay		
Total Delay		
LOS		
Approach Delay		
Approach LOS		
Queue Length 50th (m)		
Queue Length 95th (m)		
Internal Link Dist (m)		
Turn Bay Length (m)		
Base Capacity (vph)		
Starvation Cap Reductn		
Spillback Cap Reductn		
Storage Cap Reductn		
Reduced v/c Ratio		
Intersection Summary		

Lanes, Volumes, Timings  
2: Metcalfe & Laurier

2032 Future Total  
PM Peak Hour

Maximum v/c Ratio: 0.53	
Intersection Signal Delay: 13.5	Intersection LOS: B
Intersection Capacity Utilization 48.9%	ICU Level of Service A
Analysis Period (min) 15	

Splits and Phases: 2: Metcalfe & Laurier

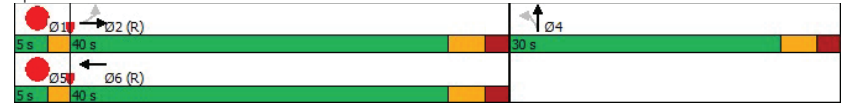

Lanes, Volumes, Timings  
3: Elgin & Laurier

2032 Future Total  
PM Peak Hour

Lane Group	EBL	EBT	EBR	WBL	WBT	WBR	NBL	NBT	NBR	SBL	SBT	SBR
Lane Configurations		↕		↕	↕	↕		↕	↕	↕	↕	
Traffic Volume (vph)	0	364	30	117	431	413	0	280	161	382	363	110
Future Volume (vph)	0	364	30	117	431	413	0	280	161	382	363	110
Satd. Flow (prot)	0	3203	0	1642	1745	1483	0	3316	1483	3154	2639	0
Flt Permitted				0.462						0.950		
Satd. Flow (perm)	0	3203	0	692	1745	976	0	3316	680	2247	2639	0
Satd. Flow (RTOR)					213				149		51	
Lane Group Flow (vph)	0	437	0	130	479	459	0	311	179	424	525	0
Turn Type		NA		custom	NA	custom		NA	pm+ov	Prot	NA	
Protected Phases		2		9	5	6		3	9	3	8	
Permitted Phases				6		6			4			
Detector Phase		2		9	5	6		3	4	9	3	8
Switch Phase												
Minimum Initial (s)		5.0		5.0		10.0		10.0	5.0	10.0		10.0
Minimum Split (s)		30.0		12.0		20.7		28.2	12.0	20.7		28.2
Total Split (s)		31.0		14.0		21.8		28.2	14.0	21.8		50.0
Total Split (%)		31.0%		14.0%		21.8%		28.2%	14.0%	21.8%		50.0%
Yellow Time (s)		3.3		3.3		3.3		3.3	3.3	3.3		3.3
All-Red Time (s)		3.7		3.7		4.4		2.9	3.7	4.4		2.9
Lost Time Adjust (s)		0.0		0.0		0.0		0.0	0.0	0.0		0.0
Total Lost Time (s)		7.0		7.0		7.7		6.2	7.0	7.7		6.2
Lead/Lag				Lead		Lead		Lag	Lead		Lead	
Lead-Lag Optimize?				Yes		Yes		Yes	Yes		Yes	
Recall Mode		C-Max		None		None		Max	None	None		Max
Act Effct Green (s)		29.0		35.0		48.0		22.0	28.2	14.1		43.8
Actuated g/C Ratio		0.29		0.35		0.48		0.22	0.28	0.14		0.44
v/c Ratio		0.47		0.42		0.57		0.43	0.51	0.95		0.44
Control Delay		31.2		23.1		22.0		25.1	8.4	76.6		19.0
Queue Delay		0.0		0.0		0.0		0.0	0.0	0.0		0.0
Total Delay		31.2		23.1		22.0		25.1	8.4	76.6		19.0
LOS		C		C		C		C	A	E		B
Approach Delay		31.2				21.9		19.0				44.7
Approach LOS		C				C		B				D
Queue Length 50th (m)		36.5		15.2		64.1		16.4	1.4	42.6		32.5
Queue Length 95th (m)		51.0		27.2		94.8		23.6	9.1	71.4		46.4
Internal Link Dist (m)		50.9				106.8		136.3				52.8
Turn Bay Length (m)									90.0	85.0		
Base Capacity (vph)		929		308		837		729	354	444		1184
Starvation Cap Reductn		0		0		0		0	0	0		0
Spillback Cap Reductn		0		0		0		0	0	0		0
Storage Cap Reductn		0		0		0		0	0	0		0
Reduced v/c Ratio		0.47		0.42		0.57		0.43	0.51	0.95		0.44

Intersection Summary  
 Cycle Length: 100  
 Actuated Cycle Length: 100  
 Offset: 52 (52%), Referenced to phase 2:EBT and 6:WBTL, Start of Green  
 Natural Cycle: 100  
 Control Type: Actuated-Coordinated

Lanes, Volumes, Timings  
3: Elgin & Laurier

2032 Future Total  
PM Peak Hour

Lane Group	Ø1	Ø5	Ø6	Ø13
Lane Configurations				
Traffic Volume (vph)				
Future Volume (vph)				
Satd. Flow (prot)				
Flt Permitted				
Satd. Flow (perm)				
Satd. Flow (RTOR)				
Lane Group Flow (vph)				
Turn Type				
Protected Phases	1	5	6	13
Permitted Phases				
Detector Phase				
Switch Phase				
Minimum Initial (s)	1.0	1.0	5.0	1.0
Minimum Split (s)	5.0	7.0	25.0	5.0
Total Split (s)	5.0	10.0	35.0	5.0
Total Split (%)	5%	10%	35%	5%
Yellow Time (s)	2.0	2.0	2.0	2.0
All-Red Time (s)	0.0	0.0	0.0	0.0
Lost Time Adjust (s)				
Total Lost Time (s)				
Lead/Lag	Lag	Lag		Lead
Lead-Lag Optimize?	Yes	Yes		Yes
Recall Mode	None	None	C-Max	None
Act Effct Green (s)				
Actuated g/C Ratio				
v/c Ratio				
Control Delay				
Queue Delay				
Total Delay				
LOS				
Approach Delay				
Approach LOS				
Queue Length 50th (m)				
Queue Length 95th (m)				
Internal Link Dist (m)				
Turn Bay Length (m)				
Base Capacity (vph)				
Starvation Cap Reductn				
Spillback Cap Reductn				
Storage Cap Reductn				
Reduced v/c Ratio				

Intersection Summary

Lanes, Volumes, Timings  
3: Elgin & Laurier

2032 Future Total  
PM Peak Hour

Maximum v/c Ratio: 0.95	Intersection LOS: C
Intersection Signal Delay: 30.2	ICU Level of Service D
Intersection Capacity Utilization 79.1%	
Analysis Period (min) 15	
# 95th percentile volume exceeds capacity, queue may be longer.	
Queue shown is maximum after two cycles.	

Splits and Phases: 3: Elgin & Laurier

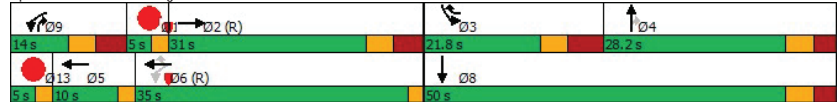

Lanes, Volumes, Timings  
4: Metcalfe & Gloucester

2032 Future Total  
PM Peak Hour

Lane Group	EBL	EBT	EBR	WBL	WBT	WBR	NBL	NBT	NBR	SBL	SBT	SBR
Lane Configurations					↑↑			↑↑↑				
Traffic Volume (vph)	0	0	0	0	209	127	114	444	0	0	0	0
Future Volume (vph)	0	0	0	0	209	127	114	444	0	0	0	0
Satd. Flow (prot)	0	0	0	0	2923	0	0	4716	0	0	0	0
Flt Permitted								0.990				
Satd. Flow (perm)	0	0	0	0	2923	0	0	4413	0	0	0	0
Satd. Flow (RTOR)					16			92				
Lane Group Flow (vph)	0	0	0	0	373	0	0	620	0	0	0	0
Turn Type					NA			Perm	NA			
Protected Phases					4			2				
Permitted Phases								2				
Detector Phase					4			2	2			
Switch Phase												
Minimum Initial (s)					10.0			10.0	10.0			
Minimum Split (s)					23.1			35.0	35.0			
Total Split (s)					30.0			45.0	45.0			
Total Split (%)					40.0%			60.0%	60.0%			
Yellow Time (s)					3.3			3.3	3.3			
All-Red Time (s)					1.8			1.7	1.7			
Lost Time Adjust (s)					0.0			0.0	0.0			
Total Lost Time (s)					5.1			5.0	5.0			
Lead/Lag												
Lead-Lag Optimize?												
Recall Mode					Max			C-Max	C-Max			
Act Effct Green (s)					24.9			35.0	40.0			
Actuated g/C Ratio					0.33			0.53	0.53			
v/c Ratio					0.38			0.26	0.26			
Control Delay					19.7			8.3	8.3			
Queue Delay					0.0			0.0	0.0			
Total Delay					19.7			8.3	8.3			
LOS					B			A	A			
Approach Delay					19.7			8.3	8.3			
Approach LOS					B			A	A			
Queue Length 50th (m)					19.9			13.4	13.4			
Queue Length 95th (m)					30.9			19.4	19.4			
Internal Link Dist (m)						34.9		48.3	35.0			51.7
Turn Bay Length (m)												
Base Capacity (vph)					981			2396	2396			
Starvation Cap Reductn					0			0	0			
Spillback Cap Reductn					0			0	0			
Storage Cap Reductn					0			0	0			
Reduced v/c Ratio					0.38			0.26	0.26			

Intersection Summary

Cycle Length: 75
Actuated Cycle Length: 75
Offset: 67 (89%), Referenced to phase 2:NBTL, Start of Green
Natural Cycle: 60
Control Type: Actuated-Coordinated

Lanes, Volumes, Timings  
4: Metcalfe & Gloucester

2032 Future Total  
PM Peak Hour

Maximum v/c Ratio: 0.38	Intersection LOS: B
Intersection Signal Delay: 12.6	ICU Level of Service A
Intersection Capacity Utilization 41.9%	
Analysis Period (min) 15	

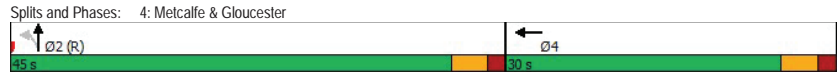

Lanes, Volumes, Timings  
5: Elgin & Nepean/City Hall

2032 Future Total  
PM Peak Hour

Lane Group	EBL	EBT	EBR	WBL	WBT	WBR	NBL	NBT	NBR	SBL	SBT	SBR
Lane Configurations		↔		↔		↔		↔		↔	↔	↔
Traffic Volume (vph)	113	1	107	31	0	23	0	328	5	7	465	0
Future Volume (vph)	113	1	107	31	0	23	0	328	5	7	465	0
Satd. Flow (prot)	0	1491	0	1658	0	1483	0	3260	0	1658	3316	0
Flt Permitted		0.975		0.605						0.516		
Satd. Flow (perm)	0	1397	0	983	0	1286	0	3260	0	744	3316	0
Satd. Flow (RTOR)		55				48		2				
Lane Group Flow (vph)	0	246	0	34	0	26	0	370	0	8	517	0
Turn Type	Perm	NA	Perm	Perm	Perm	NA	Perm	NA	Perm	NA	NA	NA
Protected Phases		4						2			6	
Permitted Phases	4			8		8				6		
Detector Phase	4	4		8		8		2		6	6	
Switch Phase												
Minimum Initial (s)	10.0	10.0		10.0		10.0		10.0		10.0	10.0	
Minimum Split (s)	25.1	25.1		25.1		25.1		31.4		31.4	31.4	
Total Split (s)	45.0	45.0		45.0		45.0		50.0		50.0	50.0	
Total Split (%)	45.0%	45.0%		45.0%		45.0%		50.0%		50.0%	50.0%	
Yellow Time (s)	3.3	3.3		3.3		3.3		3.3		3.3	3.3	
All-Red Time (s)	2.8	2.8		2.8		2.8		2.1		2.1	2.1	
Lost Time Adjust (s)		0.0		0.0		0.0		0.0		0.0	0.0	
Total Lost Time (s)		6.1		6.1		6.1		5.4		5.4	5.4	
Lead/Lag	Lag	Lag		Lag		Lag						
Lead-Lag Optimize?	Yes	Yes		Yes		Yes						
Recall Mode	Max	Max		Max		Max		C-Max		C-Max	C-Max	
Act Effct Green (s)		43.9		43.9		43.9		44.6		44.6	44.6	
Actuated g/C Ratio		0.44		0.44		0.44		0.45		0.45	0.45	
v/c Ratio		0.38		0.08		0.04		0.25		0.02	0.35	
Control Delay		16.5		17.1		2.0		17.8		13.6	17.9	
Queue Delay		0.0		0.0		0.0		0.0		0.0	0.0	
Total Delay		16.5		17.1		2.0		17.8		13.6	17.9	
LOS		B		B		A		B		B	B	
Approach Delay		16.5				10.6		17.8			17.9	
Approach LOS		B				B		B			B	
Queue Length 50th (m)		23.7		3.7		0.0		22.7		0.6	39.5	
Queue Length 95th (m)		42.7		9.6		2.2		32.5		m1.2	48.3	
Internal Link Dist (m)		54.5				21.0		120.5			136.3	
Turn Bay Length (m)										20.0		
Base Capacity (vph)		644		431		591		1455		331	1478	
Starvation Cap Reductn		0		0		0		0		0	0	
Spillback Cap Reductn		0		0		0		0		0	0	
Storage Cap Reductn		0		0		0		0		0	0	
Reduced v/c Ratio		0.38		0.08		0.04		0.25		0.02	0.35	

Intersection Summary	
Cycle Length:	100
Actuated Cycle Length:	100
Offset:	0 (0%), Referenced to phase 2:NBT and 6:SBTL, Start of Green
Natural Cycle:	65
Control Type:	Actuated-Coordinated

Lanes, Volumes, Timings  
5: Elgin & Nepean/City Hall

2032 Future Total  
PM Peak Hour

Lane Group	Ø3	Ø7
Lane Configurations		
Traffic Volume (vph)		
Future Volume (vph)		
Satd. Flow (prot)		
Flt Permitted		
Satd. Flow (perm)		
Satd. Flow (RTOR)		
Lane Group Flow (vph)		
Turn Type		
Protected Phases	3	7
Permitted Phases		
Detector Phase		
Switch Phase		
Minimum Initial (s)	1.0	1.0
Minimum Split (s)	5.0	5.0
Total Split (s)	5.0	5.0
Total Split (%)	5%	5%
Yellow Time (s)	2.0	2.0
All-Red Time (s)	0.0	0.0
Lost Time Adjust (s)		
Total Lost Time (s)		
Lead/Lag	Lead	Lead
Lead-Lag Optimize?	Yes	Yes
Recall Mode	None	None
Act Effct Green (s)		
Actuated g/C Ratio		
v/c Ratio		
Control Delay		
Queue Delay		
Total Delay		
LOS		
Approach Delay		
Approach LOS		
Queue Length 50th (m)		
Queue Length 95th (m)		
Internal Link Dist (m)		
Turn Bay Length (m)		
Base Capacity (vph)		
Starvation Cap Reductn		
Spillback Cap Reductn		
Storage Cap Reductn		
Reduced v/c Ratio		
Intersection Summary		

Lanes, Volumes, Timings  
5: Elgin & Nepean/City Hall

2032 Future Total  
PM Peak Hour

Maximum v/c Ratio: 0.38	
Intersection Signal Delay: 17.2	Intersection LOS: B
Intersection Capacity Utilization 66.6%	ICU Level of Service C
Analysis Period (min) 15	
m Volume for 95th percentile queue is metered by upstream signal.	

Splits and Phases: 5: Elgin & Nepean/City Hall

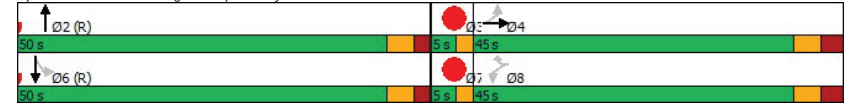



Lanes, Volumes, Timings  
6: Access & Laurier

2032 Future Total  
PM Peak Hour

Lane Group	EBT	EBR	WBL	WBT	NBL	NBR
Lane Configurations	↑			↑	↑	↑
Traffic Volume (vph)	451	12	4	482	9	3
Future Volume (vph)	451	12	4	482	9	3
Satd. Flow (prot)	1740	0	0	1745	1628	0
Flt Permitted				0.963		
Satd. Flow (perm)	1740	0	0	1745	1628	0
Lane Group Flow (vph)	514	0	0	540	13	0
Sign Control	Free			Free	Stop	
<b>Intersection Summary</b>						
Control Type:	Unsignalized					
Intersection Capacity Utilization	40.1%			ICU Level of Service A		
Analysis Period (min)	15					

HCM 2010 TWSC  
6: Access & Laurier

2032 Future Total  
PM Peak Hour

<b>Intersection</b>						
Int Delay, s/veh	0.3					
Movement	EBT	EBR	WBL	WBT	NBL	NBR
Lane Configurations	↑			↑	↑	↑
Traffic Vol, veh/h	451	12	4	482	9	3
Future Vol, veh/h	451	12	4	482	9	3
Conflicting Peds, #/hr	0	0	0	0	0	0
Sign Control	Free	Free	Free	Free	Stop	Stop
RT Channelized	-	None	-	None	-	None
Storage Length	-	-	-	-	0	-
Veh in Median Storage, #	0	-	-	0	0	-
Grade, %	0	-	-	0	0	-
Peak Hour Factor	90	90	90	90	90	90
Heavy Vehicles, %	2	2	2	2	2	2
Mvmt Flow	501	13	4	536	10	3

Major/Minor	Major1	Major2	Minor1
Conflicting Flow All	0	0	514
Stage 1	-	-	508
Stage 2	-	-	544
Critical Hdwy	-	4.12	6.42
Critical Hdwy Stg 1	-	-	5.42
Critical Hdwy Stg 2	-	-	5.42
Follow-up Hdwy	-	2.218	3.318
Pot Cap-1 Maneuver	-	1052	251
Stage 1	-	-	604
Stage 2	-	-	582
Platoon blocked, %	-	-	-
Mov Cap-1 Maneuver	-	1052	250
Mov Cap-2 Maneuver	-	-	250
Stage 1	-	-	604
Stage 2	-	-	579

Approach	EB	WB	NB
HCM Control Delay, s	0	0.1	18
HCM LOS			C

Minor Lane/Major Mvmt	NBLn1	EBT	EBR	WBL	WBT
Capacity (veh/h)	290	-	-	1052	-
HCM Lane V/C Ratio	0.046	-	-	0.004	-
HCM Control Delay (s)	18	-	-	8.4	-
HCM Lane LOS	C	-	-	A	-
HCM 95th %tile Q(veh)	0.1	-	-	0	-

# Appendix K

Turning Templates

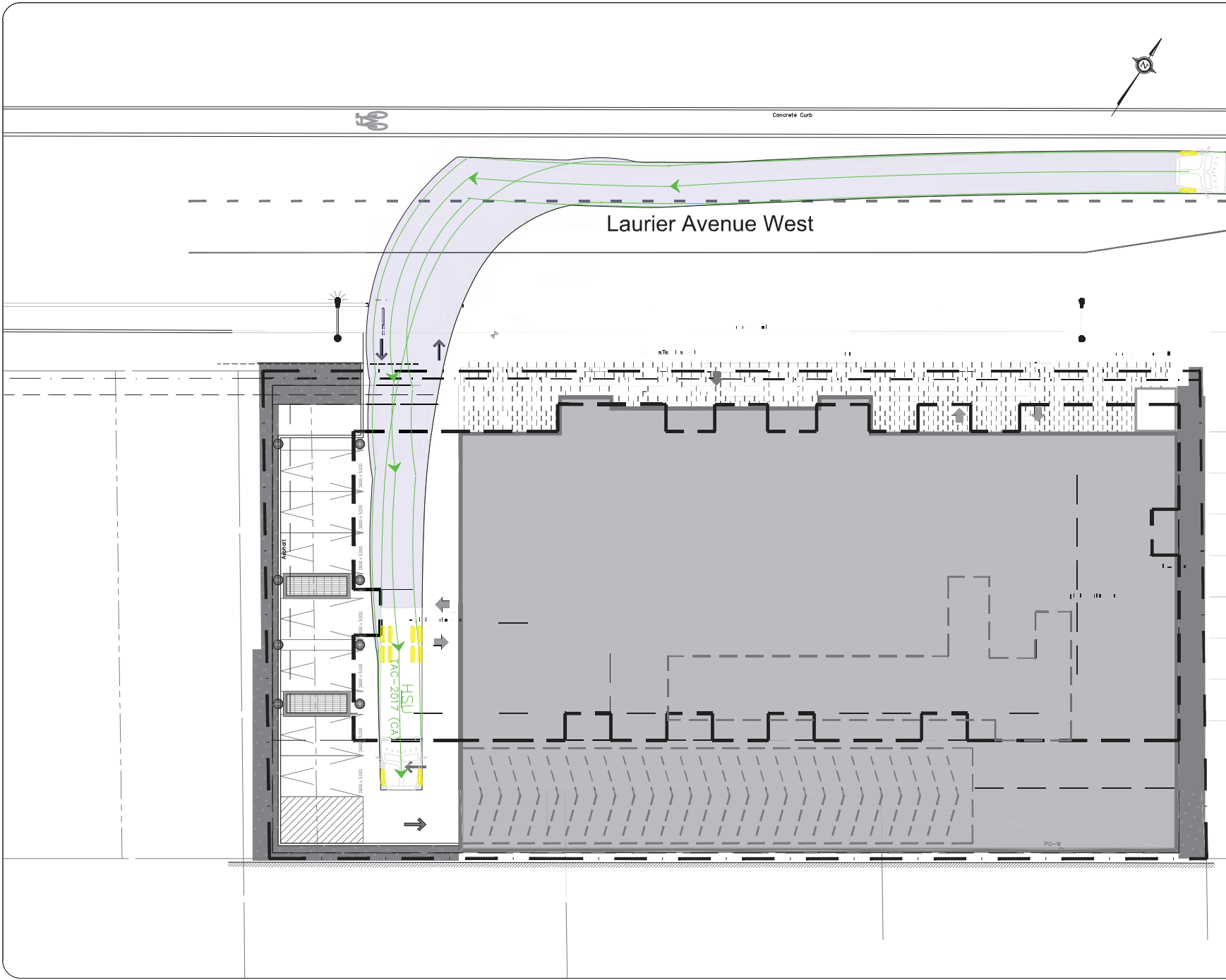

Notes:

11500

800 8400

**HSU**

mm

Width : 2600  
 Track : 2600  
 Lock to Lock Time : 6.0  
 Steering Angle : 40.0

01	Issued for Review	AN	2022-08-26
REV:	DESCRIPTION:	BY:	DATE:
STATUS:			

**CGH Transportation**  
 6 Plaza Court  
 Ottawa, ON  
 K2H 7W1  
 (343) 999-9117

CLIENT: **Jadco Group**

ARCHITECT:

SITE: **150 Laurier Avenue W**

TITLE: **Turning Movement Analysis  
 HSU Movement (1)**

SCALE AT A3:	DATE:	DRAWN:	CHECKED:
NTS	2022-08-26	AN	AH
PROJECT NO:	DRAWING NO:	REVISION:	
2022-074	001	01	

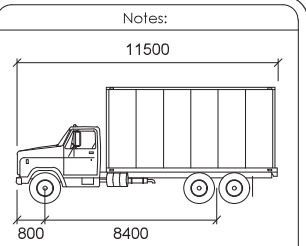
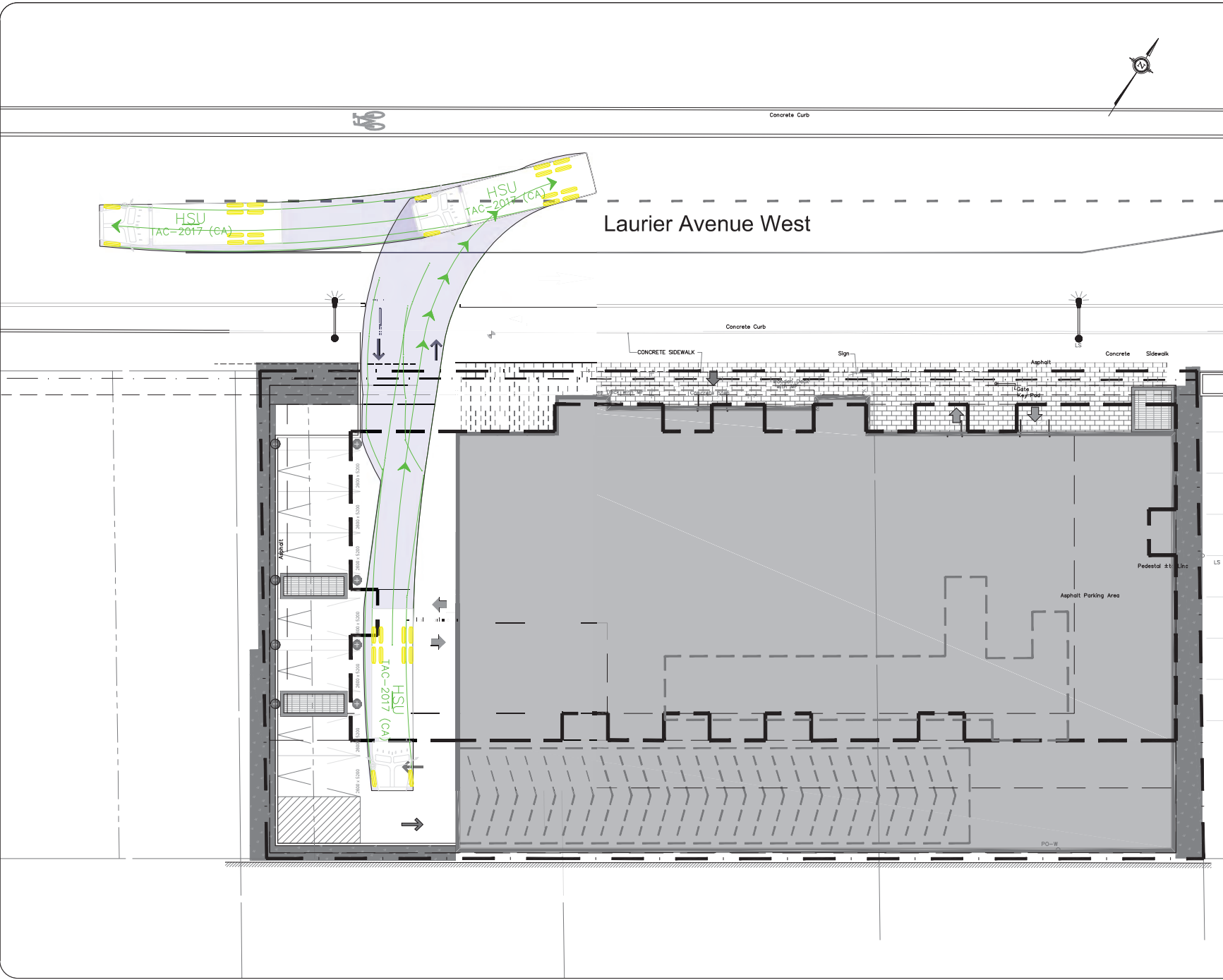

**HSU**

mm

Width : 2600  
 Track : 2600  
 Lock to Lock Time : 6.0  
 Steering Angle : 40.0

01	Issued for Review	AN	2022-08-26
REV:	DESCRIPTION:	BY:	DATE:
STATUS:			



**CGH Transportation**  
 6 Plaza Court  
 Ottawa, ON  
 K2H 7W1  
 (343) 999-9117

CLIENT: **Jadco Group**

ARCHITECT:

SITE: **150 Laurier Avenue W**

TITLE: **Turning Movement Analysis  
 HSU Movement (2)**

SCALE AT A3:	DATE:	DRAWN:	CHECKED:
NTS	2022-08-26	AN	AH
PROJECT NO:	DRAWING NO:	REVISION:	
2022-074	002	01	

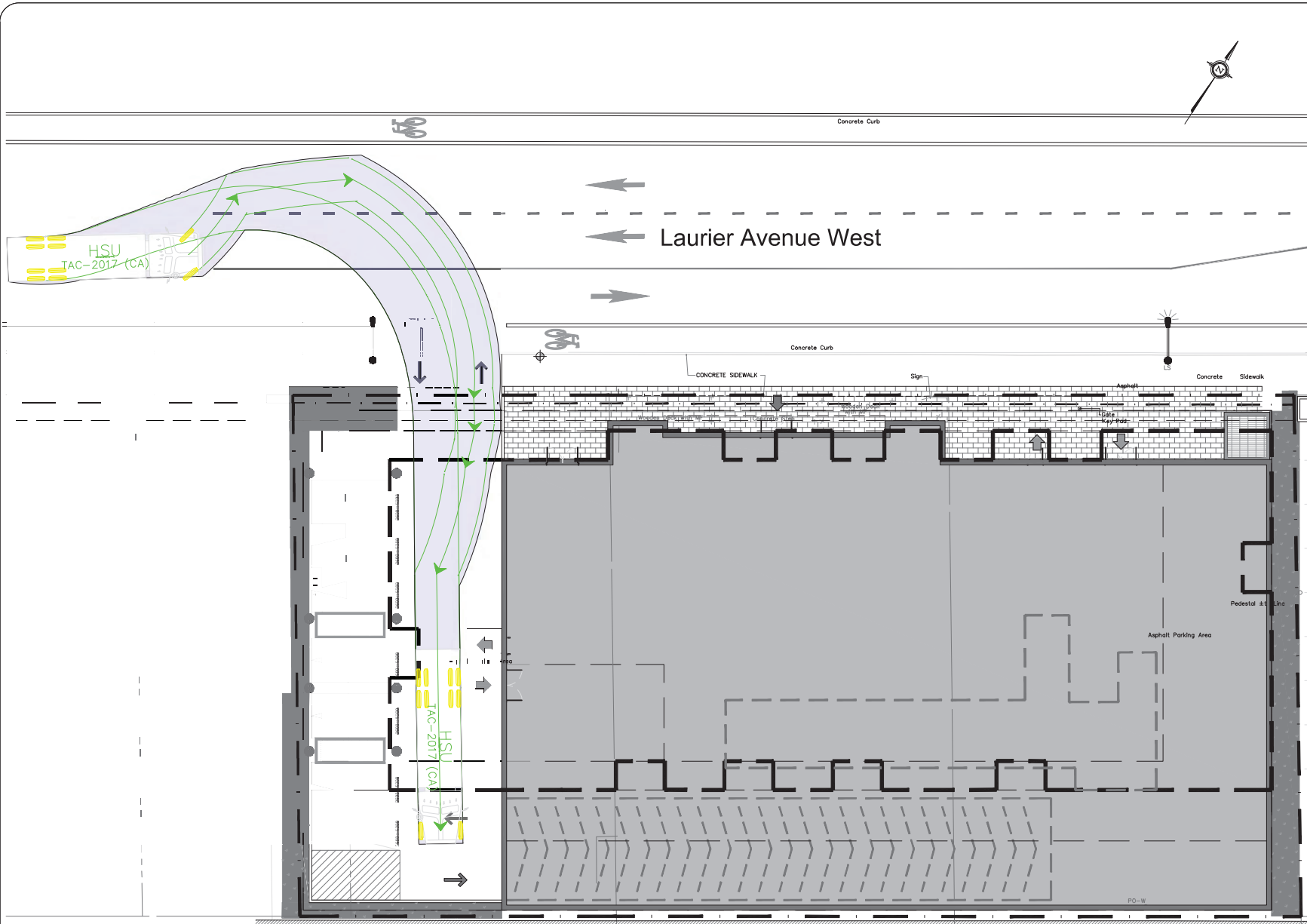

Notes:

11500

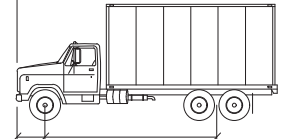

800 8400

HSU

- Width : 2600 mm
- Track : 2600 mm
- Lock to Lock Time : 6.0
- Steering Angle : 40.0

01	Issued for Review	AN	2022-08-26
REV:	DESCRIPTION:	BY:	DATE:
STATUS:			



**CGH Transportation**  
 6 Plaza Court  
 Ottawa, ON  
 K2H 7W1  
 (343) 999-9117

CLIENT: **Jadco Group**

ARCHITECT:

SITE: **150 Laurier Avenue W**

TITLE: **Turning Movement Analysis  
 HSU Movement (3)**

SCALE AT A3:	DATE:	DRAWN:	CHECKED:
NTS	2022-08-26	AN	AH
PROJECT NO:	DRAWING NO:	REVISION:	
2022-074	003	01	

# Appendix L

MMLOS Analysis

Multi-Modal Level of Service - Intersections Form

Consultant	CGH Transportation Inc.	Project	2022-074
Scenario	Existing/Future	Date	8/29/2022
Comments			

INTERSECTIONS		Laurier Avenue West at O'Connor Street				Laurier Avenue West at Metcalfe Street				Laurier Avenue West at Elgin Street				Gloucester Street at Metcalfe Street				Nepean Street at Elgin Street							
	Crossing Side	NORTH		SOUTH		EAST		WEST		NORTH		SOUTH		EAST		WEST		NORTH		SOUTH		EAST		WEST	
		Lanes		4	4	4	4	4	4	4	4	8	8	5	4	3	3	3	3	6	5	3	3	6	2
Median		No Median - 2.4 m	No Median - 2.4 m	No Median - 2.4 m	No Median - 2.4 m	No Median - 2.4 m	No Median - 2.4 m	No Median - 2.4 m	No Median - 2.4 m	No Median - 2.4 m	No Median - 2.4 m	No Median - 2.4 m	No Median - 2.4 m	No Median - 2.4 m	No Median - 2.4 m	No Median - 2.4 m	No Median - 2.4 m	No Median - 2.4 m	No Median - 2.4 m	No Median - 2.4 m	No Median - 2.4 m	No Median - 2.4 m	No Median - 2.4 m		
Conflicting Left Turns		No left turn / Prohib.	Protected/ Permissive	Permissive	No left turn / Prohib.	Permissive	No left turn / Prohib.	No left turn / Prohib.	Permissive	No left turn / Prohib.	Protected/ Permissive	Protected	No left turn / Prohib.	Permissive	No left turn / Prohib.	No left turn / Prohib.	Permissive	Permissive	Permissive	No left turn / Prohib.	Permissive	Permissive	Permissive		
Conflicting Right Turns		No right turn	Permissive or yield control	No right turn	Permissive or yield control	Permissive or yield control	No right turn	Permissive or yield control	No right turn	Protected/ Permissive	Permissive or yield control	Protected/ Permissive	Permissive or yield control	Permissive or yield control	No right turn	Permissive or yield control	No right turn	Permissive or yield control	Permissive or yield control	Permissive or yield control	Permissive or yield control	No right turn	No right turn		
Right Turns on Red (RTOR) ?		RTOR prohibited	RTOR prohibited	RTOR prohibited	RTOR prohibited	RTOR prohibited	RTOR prohibited	RTOR prohibited	RTOR prohibited	RTOR allowed	RTOR prohibited	RTOR allowed	RTOR allowed	RTOR allowed	RTOR prohibited	RTOR prohibited	RTOR allowed	RTOR allowed	RTOR allowed	RTOR allowed	RTOR allowed	RTOR prohibited	RTOR prohibited		
Ped Signal Leading Interval?		Yes	Yes	Yes	Yes	No	No	Yes	Yes	No	No	Yes	Yes	No	No	No	No	No	No	Yes	Yes	Yes	Yes		
Right Turn Channel		No Channel	No Channel	No Channel	No Channel	No Channel	No Channel	No Channel	No Channel	No Channel	No Channel	No Channel	No Channel	No Channel	No Channel	No Channel	No Channel	No Channel	No Channel	No Channel	No Channel	No Channel	No Channel		
Corner Radius		3-5m	5-10m	5-10m	3-5m	3-5m	3-5m	3-5m	3-5m	5-10m	10-15m	10-15m	5-10m	3-5m	3-5m	3-5m	3-5m	3-5m	3-5m	3-5m	3-5m	5-10m	3-5m		
Crosswalk Type		Std transverse markings	Std transverse markings	Std transverse markings	Std transverse markings	Std transverse markings	Std transverse markings	Std transverse markings	Std transverse markings	Textured/coloured pavement	Textured/coloured pavement	Textured/coloured pavement	Textured/coloured pavement	Std transverse markings	Std transverse markings	Std transverse markings	Std transverse markings	Textured/coloured pavement	Textured/coloured pavement	Textured/coloured pavement	Textured/coloured pavement	Textured/coloured pavement	Textured/coloured pavement		
PETSI Score		73	59	64	68	58	88	68	65	0	-6	50	67	72	88	80	80	25	42	84	100	25	100		
Ped. Exposure to Traffic LoS		C	D	C	C	D	B	C	C	F	F	D	C	C	B	B	B	F	E	B	A	F	A		
Cycle Length		75	75	75	75	75	75	75	75	100	100	100	100	75	75	75	75	90	90	90	90	90	90		
Effective Walk Time		15	30	19	19	14	29	29	29	36	15	21	35	34	13	34	13	36	36	7	7	7	7		
Average Pedestrian Delay		24	14	21	21	25	14	14	14	20	36	31	21	11	26	26	26	16	16	38	38	16	38		
Pedestrian Delay LoS		C	D	B	C	D	C	B	B	C	D	D	C	-	B	C	-	B	B	D	D	B	D		
Level of Service		D				D				F				C				F							
Approach From		NORTH	SOUTH	EAST	WEST	NORTH	SOUTH	EAST	WEST	NORTH	SOUTH	EAST	WEST	NORTH	SOUTH	EAST	WEST	NORTH	SOUTH	EAST	WEST	NORTH	SOUTH	EAST	WEST
Bicycle Lane Arrangement on Approach		Curb Bike Lane, Cycletrack or MUP	Curb Bike Lane, Cycletrack or MUP	Curb Bike Lane, Cycletrack or MUP	Curb Bike Lane, Cycletrack or MUP	Mixed Traffic	Mixed Traffic	Curb Bike Lane, Cycletrack or MUP	Curb Bike Lane, Cycletrack or MUP	Mixed Traffic	Mixed Traffic	Curb Bike Lane, Cycletrack or MUP	Curb Bike Lane, Cycletrack or MUP	Mixed Traffic	Mixed Traffic	Mixed Traffic	Mixed Traffic	Mixed Traffic	Mixed Traffic	Mixed Traffic	Mixed Traffic	Mixed Traffic	Mixed Traffic	Mixed Traffic	Mixed Traffic
Right Turn Lane Configuration		Not Applicable	Not Applicable	Not Applicable	Not Applicable	Not Applicable	Not Applicable	Not Applicable	Not Applicable	> 50 m	> 50 m	Not Applicable	Not Applicable	Not Applicable	Not Applicable	Not Applicable	Not Applicable	Not Applicable	Not Applicable	Not Applicable	Not Applicable	Not Applicable	Not Applicable	Not Applicable	Not Applicable
Right Turning Speed		Not Applicable	Not Applicable	Not Applicable	Not Applicable	Not Applicable	Not Applicable	Not Applicable	Not Applicable	≤ 25 km/h	≤ 25 km/h	Not Applicable	Not Applicable	Not Applicable	Not Applicable	Not Applicable	Not Applicable	Not Applicable	Not Applicable	Not Applicable	Not Applicable	Not Applicable	Not Applicable	Not Applicable	Not Applicable
Cyclist relative to RT motorists		Not Applicable	Not Applicable	Not Applicable	Not Applicable	-	#N/A	Not Applicable	Not Applicable	#N/A	F	Not Applicable	Not Applicable	-	#N/A	#N/A	-	-	#N/A	#N/A	-	-	#N/A	#N/A	#N/A
Separated or Mixed Traffic		Separated	Separated	Separated	Separated	-	Mixed Traffic	Separated	Separated	Mixed Traffic	Mixed Traffic	Separated	Separated	-	Mixed Traffic	Mixed Traffic	-	-	Mixed Traffic	Mixed Traffic	-	-	Mixed Traffic	Mixed Traffic	Mixed Traffic
Left Turn Approach		2-stage, LT box	2-stage, LT box	2-stage, LT box	2-stage, LT box	≥ 2 lanes crossed	≥ 2 lanes crossed	2-stage, LT box	2-stage, LT box	≥ 2 lanes crossed	≥ 2 lanes crossed	2-stage, LT box	2-stage, LT box	≥ 2 lanes crossed	≥ 2 lanes crossed	2-stage, LT box	2-stage, LT box	≥ 2 lanes crossed	≥ 2 lanes crossed	One lane crossed	No lane crossed	≥ 2 lanes crossed	One lane crossed	No lane crossed	No lane crossed
Operating Speed		> 50 to < 60 km/h	> 50 to < 60 km/h	> 50 to < 60 km/h	> 50 to < 60 km/h	> 50 to < 60 km/h	> 50 to < 60 km/h	> 50 to < 60 km/h	> 50 to < 60 km/h	> 50 to < 60 km/h	> 50 to < 60 km/h	> 50 to < 60 km/h	> 50 to < 60 km/h	> 50 to < 60 km/h	> 50 to < 60 km/h	> 50 to < 60 km/h	> 50 to < 60 km/h	> 50 to < 60 km/h	> 50 to < 60 km/h	> 50 to < 60 km/h	> 50 to < 60 km/h	> 50 to < 60 km/h	> 50 to < 60 km/h	> 50 to < 60 km/h	> 50 to < 60 km/h
Left Turning Cyclist		A	A	A	A	-	F	-	A	F	-	-	A	-	F	-	-	-	F	-	-	F	-	E	C
Level of Service		A	A	A	A	-	#N/A	-	A	#N/A	-	-	A	-	#N/A	#N/A	-	-	#N/A	#N/A	-	-	#N/A	#N/A	#N/A
Level of Service		A				F				F				F				F							
Average Signal Delay		-	-	-	-	-	-	-	-	≤ 20 sec	≤ 40 sec	-	-	-	-	-	-	-	-	-	-	≤ 20 sec	-	-	-
Level of Service		-				-				C				E				-							
Level of Service		-				-				E				-				C							
Effective Corner Radius		< 10 m	< 10 m	< 10 m	< 10 m	< 10 m	< 10 m	< 10 m	< 10 m	10 - 15 m	10 - 15 m	10 - 15 m	10 - 15 m	10 - 15 m	10 - 15 m	10 - 15 m	10 - 15 m	10 - 15 m	10 - 15 m	10 - 15 m	10 - 15 m	10 - 15 m	10 - 15 m	10 - 15 m	10 - 15 m
Number of Receiving Lanes on Departure from Intersection		≥ 2	≥ 2	≥ 2	≥ 2	1	≥ 2	≥ 2	≥ 2	1	≥ 2	≥ 2	≥ 2	1	≥ 2	≥ 2	≥ 2	1	≥ 2	≥ 2	≥ 2	1	≥ 2	≥ 2	≥ 2
Level of Service		D	-	-	D	-	F	D	-	E	B	B	B	-	-	-	-	-	-	-	-	-	-	-	-
Level of Service		D				F				E				-				-							
Volume to Capacity Ratio		0.61 - 0.70				0.0 - 0.60				0.61 - 0.80				0.0 - 0.60				0.0 - 0.60							
Level of Service		B				A				D				A				A							

### Multi-Modal Level of Service - Segments Form

Consultant	CGH Transportation Inc.
Scenario	Existing/Future
Comments	

Project	2022-074
Date	8/29/2022

SEGMENTS			Laurier 1	Section 2	Section 3	Section 4
Pedestrian	Sidewalk Width	-	≥ 2 m			
	Boulevard Width		0.5 - 2 m			
	Avg Daily Curb Lane Traffic Volume		> 3000			
	Operating Speed		> 50 to 60 km/h			
	On-Street Parking		no			
	<b>Exposure to Traffic PLoS</b>		<b>D</b>	-	-	-
	Effective Sidewalk Width					
	Pedestrian Volume					
<b>Crowding PLoS</b>	-	-	-	-		
<b>Level of Service</b>	-	-	-	-		
Bicycle	Type of Cycling Facility	A	Physically Separated			
	Number of Travel Lanes					
	Operating Speed					
	<b># of Lanes &amp; Operating Speed LoS</b>		-	-	-	
	Bike Lane (+ Parking Lane) Width					
	<b>Bike Lane Width LoS</b>		-	-	-	
	Bike Lane Blockages					
	<b>Blockage LoS</b>		-	-	-	
	Median Refuge Width (no median = < 1.8 m)					
	No. of Lanes at Unsignalized Crossing					
	Sidestreet Operating Speed					
<b>Unsignalized Crossing - Lowest LoS</b>	<b>A</b>	-	-	-		
<b>Level of Service</b>	<b>A</b>	-	-	-		
Transit	Facility Type	-				
	Friction or Ratio Transit:Posted Speed					
	<b>Level of Service</b>		-	-	-	
Truck	Truck Lane Width	C	≤ 3.5 m			
	Travel Lanes per Direction		1			
	<b>Level of Service</b>		<b>C</b>	-	-	-



# Appendix M

TDM Checklist

**TDM Measures Checklist:**  
*Non-Residential Developments (office, institutional, retail or industrial)*

Legend	
BASIC	The measure is generally feasible and effective, and in most cases would benefit the development and its users
BETTER	The measure could maximize support for users of sustainable modes, and optimize development performance
★	The measure is one of the most dependably effective tools to encourage the use of sustainable modes

TDM measures: <i>Non-residential developments</i>		Check if proposed & add descriptions
<b>1. TDM PROGRAM MANAGEMENT</b>		
<b>1.1 Program coordinator</b>		
BASIC	★ 1.1.1 Designate an internal coordinator, or contract with an external coordinator	<input type="checkbox"/>
<b>1.2 Travel surveys</b>		
BETTER	1.2.1 Conduct periodic surveys to identify travel-related behaviours, attitudes, challenges and solutions, and to track progress	<input type="checkbox"/>
<b>2. WALKING AND CYCLING</b>		
<b>2.1 Information on walking/cycling routes &amp; destinations</b>		
BASIC	2.1.1 Display local area maps with walking/cycling access routes and key destinations at major entrances	<input checked="" type="checkbox"/>
<b>2.2 Bicycle skills training</b>		
<i>Commuter travel</i>		
BETTER	★ 2.2.1 Offer on-site cycling courses for commuters, or subsidize off-site courses	<input type="checkbox"/>
<b>2.3 Valet bike parking</b>		
<i>Visitor travel</i>		
BETTER	2.3.1 Offer secure valet bike parking during public events when demand exceeds fixed supply (e.g. for festivals, concerts, games)	<input type="checkbox"/>

TDM measures: <i>Non-residential developments</i>		Check if proposed & add descriptions
<b>3. TRANSIT</b>		
<b>3.1 Transit information</b>		
BASIC	3.1.1 Display relevant transit schedules and route maps at entrances	<input checked="" type="checkbox"/>
BASIC	3.1.2 Provide online links to OC Transpo and STO information	<input type="checkbox"/>
BETTER	3.1.3 Provide real-time arrival information display at entrances	<input type="checkbox"/>
<b>3.2 Transit fare incentives</b>		
<i>Commuter travel</i>		
BETTER	3.2.1 Offer preloaded PRESTO cards to encourage commuters to use transit	<input type="checkbox"/>
BETTER	★ 3.2.2 Subsidize or reimburse monthly transit pass purchases by employees	<input type="checkbox"/>
<i>Visitor travel</i>		
BETTER	3.2.3 Arrange inclusion of same-day transit fare in price of tickets (e.g. for festivals, concerts, games)	<input type="checkbox"/>
<b>3.3 Enhanced public transit service</b>		
<i>Commuter travel</i>		
BETTER	3.3.1 Contract with OC Transpo to provide enhanced transit services (e.g. for shift changes, weekends)	<input type="checkbox"/>
<i>Visitor travel</i>		
BETTER	3.3.2 Contract with OC Transpo to provide enhanced transit services (e.g. for festivals, concerts, games)	<input type="checkbox"/>
<b>3.4 Private transit service</b>		
<i>Commuter travel</i>		
BETTER	3.4.1 Provide shuttle service when OC Transpo cannot offer sufficient quality or capacity to serve demand (e.g. for shift changes, weekends)	<input type="checkbox"/>
<i>Visitor travel</i>		
BETTER	3.4.2 Provide shuttle service when OC Transpo cannot offer sufficient quality or capacity to serve demand (e.g. for festivals, concerts, games)	<input type="checkbox"/>

TDM measures: <i>Non-residential developments</i>		Check if proposed & add descriptions
<b>4. RIDESHARING</b>		
<b>4.1 Ridematching service</b>		
<i>Commuter travel</i>		
BASIC	★ 4.1.1 Provide a dedicated ridematching portal at OttawaRideMatch.com	<input type="checkbox"/>
<b>4.2 Carpool parking price incentives</b>		
<i>Commuter travel</i>		
BETTER	4.2.1 Provide discounts on parking costs for registered carpools	<input type="checkbox"/>
<b>4.3 Vanpool service</b>		
<i>Commuter travel</i>		
BETTER	4.3.1 Provide a vanpooling service for long-distance commuters	<input type="checkbox"/>
<b>5. CARSHARING &amp; BIKESHARING</b>		
<b>5.1 Bikeshare stations &amp; memberships</b>		
BETTER	5.1.1 Contract with provider to install on-site bikeshare station for use by commuters and visitors	<input type="checkbox"/>
<i>Commuter travel</i>		
BETTER	5.1.2 Provide employees with bikeshare memberships for local business travel	<input type="checkbox"/>
<b>5.2 Carshare vehicles &amp; memberships</b>		
<i>Commuter travel</i>		
BETTER	5.2.1 Contract with provider to install on-site carshare vehicles and promote their use by tenants	<input type="checkbox"/>
BETTER	5.2.2 Provide employees with carshare memberships for local business travel	<input type="checkbox"/>
<b>6. PARKING</b>		
<b>6.1 Priced parking</b>		
<i>Commuter travel</i>		
BASIC	★ 6.1.1 Charge for long-term parking (daily, weekly, monthly)	<input checked="" type="checkbox"/>
BASIC	6.1.2 Unbundle parking cost from lease rates at multi-tenant sites	<input checked="" type="checkbox"/>
<i>Visitor travel</i>		
BETTER	6.1.3 Charge for short-term parking (hourly)	<input type="checkbox"/>

TDM measures: <i>Non-residential developments</i>		Check if proposed & add descriptions
<b>7. TDM MARKETING &amp; COMMUNICATIONS</b>		
<b>7.1 Multimodal travel information</b>		
<i>Commuter travel</i>		
BASIC	★ 7.1.1 Provide a multimodal travel option information package to new/relocating employees and students	<input checked="" type="checkbox"/>
<i>Visitor travel</i>		
BETTER	★ 7.1.2 Include multimodal travel option information in invitations or advertising that attract visitors or customers (e.g. for festivals, concerts, games)	<input type="checkbox"/>
<b>7.2 Personalized trip planning</b>		
<i>Commuter travel</i>		
BETTER	★ 7.2.1 Offer personalized trip planning to new/relocating employees	<input type="checkbox"/>
<b>7.3 Promotions</b>		
<i>Commuter travel</i>		
BETTER	7.3.1 Deliver promotions and incentives to maintain awareness, build understanding, and encourage trial of sustainable modes	<input type="checkbox"/>
<b>8. OTHER INCENTIVES &amp; AMENITIES</b>		
<b>8.1 Emergency ride home</b>		
<i>Commuter travel</i>		
BETTER	★ 8.1.1 Provide emergency ride home service to non-driving commuters	<input type="checkbox"/>
<b>8.2 Alternative work arrangements</b>		
<i>Commuter travel</i>		
BASIC	★ 8.2.1 Encourage flexible work hours	<input type="checkbox"/>
BETTER	8.2.2 Encourage compressed workweeks	<input type="checkbox"/>
BETTER	★ 8.2.3 Encourage telework	<input type="checkbox"/>
<b>8.3 Local business travel options</b>		
<i>Commuter travel</i>		
BASIC	★ 8.3.1 Provide local business travel options that minimize the need for employees to bring a personal car to work	<input type="checkbox"/>
<b>8.4 Commuter incentives</b>		
<i>Commuter travel</i>		
BETTER	8.4.1 Offer employees a taxable, mode-neutral commuting allowance	<input type="checkbox"/>
<b>8.5 On-site amenities</b>		
<i>Commuter travel</i>		
BETTER	8.5.1 Provide on-site amenities/services to minimize mid-day or mid-commute errands	<input type="checkbox"/>

**TDM Measures Checklist:**  
*Residential Developments (multi-family, condominium or subdivision)*

Legend	
BASIC	The measure is generally feasible and effective, and in most cases would benefit the development and its users
BETTER	The measure could maximize support for users of sustainable modes, and optimize development performance
★	The measure is one of the most dependably effective tools to encourage the use of sustainable modes

TDM measures: Residential developments		Check if proposed & add descriptions
<b>1. TDM PROGRAM MANAGEMENT</b>		
<b>1.1 Program coordinator</b>		
BASIC	★ 1.1.1 Designate an internal coordinator, or contract with an external coordinator	<input type="checkbox"/>
<b>1.2 Travel surveys</b>		
BETTER	1.2.1 Conduct periodic surveys to identify travel-related behaviours, attitudes, challenges and solutions, and to track progress	<input type="checkbox"/>
<b>2. WALKING AND CYCLING</b>		
<b>2.1 Information on walking/cycling routes &amp; destinations</b>		
BASIC	2.1.1 Display local area maps with walking/cycling access routes and key destinations at major entrances ( <i>multi-family, condominium</i> )	<input checked="" type="checkbox"/>
<b>2.2 Bicycle skills training</b>		
BETTER	2.2.1 Offer on-site cycling courses for residents, or subsidize off-site courses	<input type="checkbox"/>

TDM measures: Residential developments		Check if proposed & add descriptions
<b>3. TRANSIT</b>		
<b>3.1 Transit information</b>		
BASIC	3.1.1 Display relevant transit schedules and route maps at entrances ( <i>multi-family, condominium</i> )	<input checked="" type="checkbox"/>
BETTER	3.1.2 Provide real-time arrival information display at entrances ( <i>multi-family, condominium</i> )	<input type="checkbox"/>
<b>3.2 Transit fare incentives</b>		
BASIC	★ 3.2.1 Offer PRESTO cards preloaded with one monthly transit pass on residence purchase/move-in, to encourage residents to use transit	<input checked="" type="checkbox"/>
BETTER	3.2.2 Offer at least one year of free monthly transit passes on residence purchase/move-in	<input type="checkbox"/>
<b>3.3 Enhanced public transit service</b>		
BETTER	★ 3.3.1 Contract with OC Transpo to provide early transit services until regular services are warranted by occupancy levels ( <i>subdivision</i> )	<input type="checkbox"/>
<b>3.4 Private transit service</b>		
BETTER	3.4.1 Provide shuttle service for seniors homes or lifestyle communities (e.g. scheduled mall or supermarket runs)	<input type="checkbox"/>
<b>4. CARSHARING &amp; BIKESHARING</b>		
<b>4.1 Bikeshare stations &amp; memberships</b>		
BETTER	4.1.1 Contract with provider to install on-site bikeshare station ( <i>multi-family</i> )	<input type="checkbox"/>
BETTER	4.1.2 Provide residents with bikeshare memberships, either free or subsidized ( <i>multi-family</i> )	<input type="checkbox"/>
<b>4.2 Carshare vehicles &amp; memberships</b>		
BETTER	4.2.1 Contract with provider to install on-site carshare vehicles and promote their use by residents	<input type="checkbox"/>
BETTER	4.2.2 Provide residents with carshare memberships, either free or subsidized	<input type="checkbox"/>
<b>5. PARKING</b>		
<b>5.1 Priced parking</b>		
BASIC	★ 5.1.1 Unbundle parking cost from purchase price ( <i>condominium</i> )	<input checked="" type="checkbox"/>
BASIC	★ 5.1.2 Unbundle parking cost from monthly rent ( <i>multi-family</i> )	<input checked="" type="checkbox"/>

TDM measures: Residential developments		Check if proposed & add descriptions
<b>6. TDM MARKETING &amp; COMMUNICATIONS</b>		
<b>6.1 Multimodal travel information</b>		
BASIC ★	6.1.1 Provide a multimodal travel option information package to new residents	<input checked="" type="checkbox"/>
<b>6.2 Personalized trip planning</b>		
BETTER ★	6.2.1 Offer personalized trip planning to new residents	<input type="checkbox"/>

**TDM-Supportive Development Design and Infrastructure Checklist:**  
*Non-Residential Developments (office, institutional, retail or industrial)*

Legend	
<b>REQUIRED</b>	The Official Plan or Zoning By-law provides related guidance that must be followed
<b>BASIC</b>	The measure is generally feasible and effective, and in most cases would benefit the development and its users
<b>BETTER</b>	The measure could maximize support for users of sustainable modes, and optimize development performance

TDM-supportive design & infrastructure measures: Non-residential developments		Check if completed & add descriptions, explanations or plan/drawing references
<b>1. WALKING &amp; CYCLING: ROUTES</b>		
<b>1.1 Building location &amp; access points</b>		
BASIC	1.1.1 Locate building close to the street, and do not locate parking areas between the street and building entrances	<input checked="" type="checkbox"/>
BASIC	1.1.2 Locate building entrances in order to minimize walking distances to sidewalks and transit stops/stations	<input checked="" type="checkbox"/>
BASIC	1.1.3 Locate building doors and windows to ensure visibility of pedestrians from the building, for their security and comfort	<input checked="" type="checkbox"/>
<b>1.2 Facilities for walking &amp; cycling</b>		
REQUIRED	1.2.1 Provide convenient, direct access to stations or major stops along rapid transit routes within 600 metres; minimize walking distances from buildings to rapid transit; provide pedestrian-friendly, weather-protected (where possible) environment between rapid transit accesses and building entrances; ensure quality linkages from sidewalks through building entrances to integrated stops/stations (see <i>Official Plan policy 4.3.3</i> )	<input checked="" type="checkbox"/>
REQUIRED	1.2.2 Provide safe, direct and attractive pedestrian access from public sidewalks to building entrances through such measures as: reducing distances between public sidewalks and major building entrances; providing walkways from public streets to major building entrances; within a site, providing walkways along the front of adjoining buildings, between adjacent buildings, and connecting areas where people may congregate, such as courtyards and transit stops; and providing weather protection through canopies, colonnades, and other design elements wherever possible (see <i>Official Plan policy 4.3.12</i> )	<input checked="" type="checkbox"/>

TDM-supportive design & infrastructure measures: <i>Non-residential developments</i>		Check if completed & add descriptions, explanations or plan/drawing references
REQUIRED	1.2.3 Provide sidewalks of smooth, well-drained walking surfaces of contrasting materials or treatments to differentiate pedestrian areas from vehicle areas, and provide marked pedestrian crosswalks at intersection sidewalks (see <i>Official Plan policy 4.3.10</i> )	<input checked="" type="checkbox"/>
REQUIRED	1.2.4 Make sidewalks and open space areas easily accessible through features such as gradual grade transition, depressed curbs at street corners and convenient access to extra-wide parking spaces and ramps (see <i>Official Plan policy 4.3.10</i> )	<input checked="" type="checkbox"/>
REQUIRED	1.2.5 Include adequately spaced inter-block/street cycling and pedestrian connections to facilitate travel by active transportation. Provide links to the existing or planned network of public sidewalks, multi-use pathways and on-road cycle routes. Where public sidewalks and multi-use pathways intersect with roads, consider providing traffic control devices to give priority to cyclists and pedestrians (see <i>Official Plan policy 4.3.11</i> )	<input type="checkbox"/>
BASIC	1.2.6 Provide safe, direct and attractive walking routes from building entrances to nearby transit stops	<input type="checkbox"/>
BASIC	1.2.7 Ensure that walking routes to transit stops are secure, visible, lighted, shaded and wind-protected wherever possible	<input type="checkbox"/>
BASIC	1.2.8 Design roads used for access or circulation by cyclists using a target operating speed of no more than 30 km/h, or provide a separated cycling facility	<input type="checkbox"/>
<b>1.3 Amenities for walking &amp; cycling</b>		
BASIC	1.3.1 Provide lighting, landscaping and benches along walking and cycling routes between building entrances and streets, sidewalks and trails	<input type="checkbox"/>
BASIC	1.3.2 Provide wayfinding signage for site access (where required, e.g. when multiple buildings or entrances exist) and egress (where warranted, such as when directions to reach transit stops/stations, trails or other common destinations are not obvious)	<input type="checkbox"/>

TDM-supportive design & infrastructure measures: <i>Non-residential developments</i>		Check if completed & add descriptions, explanations or plan/drawing references
<b>2. WALKING &amp; CYCLING: END-OF-TRIP FACILITIES</b>		
<b>2.1 Bicycle parking</b>		
REQUIRED	2.1.1 Provide bicycle parking in highly visible and lighted areas, sheltered from the weather wherever possible (see <i>Official Plan policy 4.3.6</i> )	<input checked="" type="checkbox"/>
REQUIRED	2.1.2 Provide the number of bicycle parking spaces specified for various land uses in different parts of Ottawa; provide convenient access to main entrances or well-used areas (see <i>Zoning By-law Section 111</i> )	<input checked="" type="checkbox"/>
REQUIRED	2.1.3 Ensure that bicycle parking spaces and access aisles meet minimum dimensions; that no more than 50% of spaces are vertical spaces; and that parking racks are securely anchored (see <i>Zoning By-law Section 111</i> )	<input checked="" type="checkbox"/>
BASIC	2.1.4 Provide bicycle parking spaces equivalent to the expected number of commuter cyclists (assuming the cycling mode share target is met), plus the expected peak number of customer/visitor cyclists	<input type="checkbox"/>
BETTER	2.1.5 Provide bicycle parking spaces equivalent to the expected number of commuter and customer/visitor cyclists, plus an additional buffer (e.g. 25 percent extra) to encourage other cyclists and ensure adequate capacity in peak cycling season	<input type="checkbox"/>
<b>2.2 Secure bicycle parking</b>		
REQUIRED	2.2.1 Where more than 50 bicycle parking spaces are provided for a single office building, locate at least 25% of spaces within a building/structure, a secure area (e.g. supervised parking lot or enclosure) or bicycle lockers (see <i>Zoning By-law Section 111</i> )	<input checked="" type="checkbox"/>
BETTER	2.2.2 Provide secure bicycle parking spaces equivalent to the expected number of commuter cyclists (assuming the cycling mode share target is met)	<input type="checkbox"/>
<b>2.3 Shower &amp; change facilities</b>		
BASIC	2.3.1 Provide shower and change facilities for the use of active commuters	<input type="checkbox"/>
BETTER	2.3.2 In addition to shower and change facilities, provide dedicated lockers, grooming stations, drying racks and laundry facilities for the use of active commuters	<input type="checkbox"/>
<b>2.4 Bicycle repair station</b>		
BETTER	2.4.1 Provide a permanent bike repair station, with commonly used tools and an air pump, adjacent to the main bicycle parking area (or secure bicycle parking area, if provided)	<input type="checkbox"/>

TDM-supportive design & infrastructure measures: <i>Non-residential developments</i>		Check if completed & add descriptions, explanations or plan/drawing references
<b>3. TRANSIT</b>		
<b>3.1 Customer amenities</b>		
BASIC	3.1.1 Provide shelters, lighting and benches at any on-site transit stops	<input type="checkbox"/>
BASIC	3.1.2 Where the site abuts an off-site transit stop and insufficient space exists for a transit shelter in the public right-of-way, protect land for a shelter and/or install a shelter	<input type="checkbox"/>
BETTER	3.1.3 Provide a secure and comfortable interior waiting area by integrating any on-site transit stops into the building	<input type="checkbox"/>
<b>4. RIDESHARING</b>		
<b>4.1 Pick-up &amp; drop-off facilities</b>		
BASIC	4.1.1 Provide a designated area for carpool drivers (plus taxis and ride-hailing services) to drop off or pick up passengers without using fire lanes or other no-stopping zones	<input type="checkbox"/>
<b>4.2 Carpool parking</b>		
BASIC	4.2.1 Provide signed parking spaces for carpools in a priority location close to a major building entrance, sufficient in number to accommodate the mode share target for carpools	<input type="checkbox"/>
BETTER	4.2.2 At large developments, provide spaces for carpools in a separate, access-controlled parking area to simplify enforcement	<input type="checkbox"/>
<b>5. CARSHARING &amp; BIKESHARING</b>		
<b>5.1 Carshare parking spaces</b>		
BETTER	5.1.1 Provide carshare parking spaces in permitted non-residential zones, occupying either required or provided parking spaces ( <i>see Zoning By-law Section 94</i> )	<input type="checkbox"/>
<b>5.2 Bikeshare station location</b>		
BETTER	5.2.1 Provide a designated bikeshare station area near a major building entrance, preferably lighted and sheltered with a direct walkway connection	<input type="checkbox"/>

TDM-supportive design & infrastructure measures: <i>Non-residential developments</i>		Check if completed & add descriptions, explanations or plan/drawing references
<b>6. PARKING</b>		
<b>6.1 Number of parking spaces</b>		
REQUIRED	6.1.1 Do not provide more parking than permitted by zoning, nor less than required by zoning, unless a variance is being applied for	<input checked="" type="checkbox"/>
BASIC	6.1.2 Provide parking for long-term and short-term users that is consistent with mode share targets, considering the potential for visitors to use off-site public parking	<input type="checkbox"/>
BASIC	6.1.3 Where a site features more than one use, provide shared parking and reduce the cumulative number of parking spaces accordingly ( <i>see Zoning By-law Section 104</i> )	<input checked="" type="checkbox"/>
BETTER	6.1.4 Reduce the minimum number of parking spaces required by zoning by one space for each 13 square metres of gross floor area provided as shower rooms, change rooms, locker rooms and other facilities for cyclists in conjunction with bicycle parking ( <i>see Zoning By-law Section 111</i> )	<input type="checkbox"/>
<b>6.2 Separate long-term &amp; short-term parking areas</b>		
BETTER	6.2.1 Separate short-term and long-term parking areas using signage or physical barriers, to permit access controls and simplify enforcement (i.e. to discourage employees from parking in visitor spaces, and vice versa)	<input type="checkbox"/>
<b>7. OTHER</b>		
<b>7.1 On-site amenities to minimize off-site trips</b>		
BETTER	7.1.1 Provide on-site amenities to minimize mid-day or mid-commute errands	<input type="checkbox"/>

**TDM-Supportive Development Design and Infrastructure Checklist:**  
*Residential Developments (multi-family or condominium)*

Legend	
REQUIRED	The Official Plan or Zoning By-law provides related guidance that must be followed
BASIC	The measure is generally feasible and effective, and in most cases would benefit the development and its users
BETTER	The measure could maximize support for users of sustainable modes, and optimize development performance

TDM-supportive design & infrastructure measures: <i>Residential developments</i>		Check if completed & add descriptions, explanations or plan/drawing references
<b>1. WALKING &amp; CYCLING: ROUTES</b>		
<b>1.1 Building location &amp; access points</b>		
BASIC	1.1.1 Locate building close to the street, and do not locate parking areas between the street and building entrances	<input checked="" type="checkbox"/>
BASIC	1.1.2 Locate building entrances in order to minimize walking distances to sidewalks and transit stops/stations	<input checked="" type="checkbox"/>
BASIC	1.1.3 Locate building doors and windows to ensure visibility of pedestrians from the building, for their security and comfort	<input checked="" type="checkbox"/>
<b>1.2 Facilities for walking &amp; cycling</b>		
REQUIRED	1.2.1 Provide convenient, direct access to stations or major stops along rapid transit routes within 600 metres; minimize walking distances from buildings to rapid transit; provide pedestrian-friendly, weather-protected (where possible) environment between rapid transit accesses and building entrances; ensure quality linkages from sidewalks through building entrances to integrated stops/stations (see <i>Official Plan policy 4.3.3</i> )	<input checked="" type="checkbox"/>
REQUIRED	1.2.2 Provide safe, direct and attractive pedestrian access from public sidewalks to building entrances through such measures as: reducing distances between public sidewalks and major building entrances; providing walkways from public streets to major building entrances; within a site, providing walkways along the front of adjoining buildings, between adjacent buildings, and connecting areas where people may congregate, such as courtyards and transit stops; and providing weather protection through canopies, colonnades, and other design elements wherever possible (see <i>Official Plan policy 4.3.12</i> )	<input checked="" type="checkbox"/>

TDM-supportive design & infrastructure measures: <i>Residential developments</i>		Check if completed & add descriptions, explanations or plan/drawing references
REQUIRED	1.2.3 Provide sidewalks of smooth, well-drained walking surfaces of contrasting materials or treatments to differentiate pedestrian areas from vehicle areas, and provide marked pedestrian crosswalks at intersection sidewalks (see <i>Official Plan policy 4.3.10</i> )	<input checked="" type="checkbox"/>
REQUIRED	1.2.4 Make sidewalks and open space areas easily accessible through features such as gradual grade transition, depressed curbs at street corners and convenient access to extra-wide parking spaces and ramps (see <i>Official Plan policy 4.3.10</i> )	<input checked="" type="checkbox"/>
REQUIRED	1.2.5 Include adequately spaced inter-block/street cycling and pedestrian connections to facilitate travel by active transportation. Provide links to the existing or planned network of public sidewalks, multi-use pathways and on-road cycle routes. Where public sidewalks and multi-use pathways intersect with roads, consider providing traffic control devices to give priority to cyclists and pedestrians (see <i>Official Plan policy 4.3.11</i> )	<input type="checkbox"/>
BASIC	1.2.6 Provide safe, direct and attractive walking routes from building entrances to nearby transit stops	<input type="checkbox"/>
BASIC	1.2.7 Ensure that walking routes to transit stops are secure, visible, lighted, shaded and wind-protected wherever possible	<input type="checkbox"/>
BASIC	1.2.8 Design roads used for access or circulation by cyclists using a target operating speed of no more than 30 km/h, or provide a separated cycling facility	<input type="checkbox"/>
<b>1.3 Amenities for walking &amp; cycling</b>		
BASIC	1.3.1 Provide lighting, landscaping and benches along walking and cycling routes between building entrances and streets, sidewalks and trails	<input type="checkbox"/>
BASIC	1.3.2 Provide wayfinding signage for site access (where required, e.g. when multiple buildings or entrances exist) and egress (where warranted, such as when directions to reach transit stops/stations, trails or other common destinations are not obvious)	<input type="checkbox"/>



TDM-supportive design & infrastructure measures: <i>Residential developments</i>		Check if completed & add descriptions, explanations or plan/drawing references
<b>2. WALKING &amp; CYCLING: END-OF-TRIP FACILITIES</b>		
<b>2.1 Bicycle parking</b>		
REQUIRED	2.1.1 Provide bicycle parking in highly visible and lighted areas, sheltered from the weather wherever possible (see <i>Official Plan policy 4.3.6</i> )	<input checked="" type="checkbox"/>
REQUIRED	2.1.2 Provide the number of bicycle parking spaces specified for various land uses in different parts of Ottawa; provide convenient access to main entrances or well-used areas (see <i>Zoning By-law Section 111</i> )	<input checked="" type="checkbox"/>
REQUIRED	2.1.3 Ensure that bicycle parking spaces and access aisles meet minimum dimensions; that no more than 50% of spaces are vertical spaces; and that parking racks are securely anchored (see <i>Zoning By-law Section 111</i> )	<input checked="" type="checkbox"/>
BASIC	2.1.4 Provide bicycle parking spaces equivalent to the expected number of resident-owned bicycles, plus the expected peak number of visitor cyclists	<input type="checkbox"/>
<b>2.2 Secure bicycle parking</b>		
REQUIRED	2.2.1 Where more than 50 bicycle parking spaces are provided for a single residential building, locate at least 25% of spaces within a building/structure, a secure area (e.g. supervised parking lot or enclosure) or bicycle lockers (see <i>Zoning By-law Section 111</i> )	<input checked="" type="checkbox"/>
BETTER	2.2.2 Provide secure bicycle parking spaces equivalent to at least the number of units at condominiums or multi-family residential developments	<input type="checkbox"/>
<b>2.3 Bicycle repair station</b>		
BETTER	2.3.1 Provide a permanent bike repair station, with commonly used tools and an air pump, adjacent to the main bicycle parking area (or secure bicycle parking area, if provided)	<input type="checkbox"/>
<b>3. TRANSIT</b>		
<b>3.1 Customer amenities</b>		
BASIC	3.1.1 Provide shelters, lighting and benches at any on-site transit stops	<input type="checkbox"/>
BASIC	3.1.2 Where the site abuts an off-site transit stop and insufficient space exists for a transit shelter in the public right-of-way, protect land for a shelter and/or install a shelter	<input type="checkbox"/>
BETTER	3.1.3 Provide a secure and comfortable interior waiting area by integrating any on-site transit stops into the building	<input type="checkbox"/>

TDM-supportive design & infrastructure measures: <i>Residential developments</i>		Check if completed & add descriptions, explanations or plan/drawing references
<b>4. RIDESHARING</b>		
<b>4.1 Pick-up &amp; drop-off facilities</b>		
BASIC	4.1.1 Provide a designated area for carpool drivers (plus taxis and ride-hailing services) to drop off or pick up passengers without using fire lanes or other no-stopping zones	<input type="checkbox"/>
<b>5. CARSHARING &amp; BIKESHARING</b>		
<b>5.1 Carshare parking spaces</b>		
BETTER	5.1.1 Provide up to three carshare parking spaces in an R3, R4 or R5 Zone for specified residential uses (see <i>Zoning By-law Section 94</i> )	<input type="checkbox"/>
<b>5.2 Bikeshare station location</b>		
BETTER	5.2.1 Provide a designated bikeshare station area near a major building entrance, preferably lighted and sheltered with a direct walkway connection	<input type="checkbox"/>
<b>6. PARKING</b>		
<b>6.1 Number of parking spaces</b>		
REQUIRED	6.1.1 Do not provide more parking than permitted by zoning, nor less than required by zoning, unless a variance is being applied for	<input checked="" type="checkbox"/>
BASIC	6.1.2 Provide parking for long-term and short-term users that is consistent with mode share targets, considering the potential for visitors to use off-site public parking	<input type="checkbox"/>
BASIC	6.1.3 Where a site features more than one use, provide shared parking and reduce the cumulative number of parking spaces accordingly (see <i>Zoning By-law Section 104</i> )	<input type="checkbox"/>
BETTER	6.1.4 Reduce the minimum number of parking spaces required by zoning by one space for each 13 square metres of gross floor area provided as shower rooms, change rooms, locker rooms and other facilities for cyclists in conjunction with bicycle parking (see <i>Zoning By-law Section 111</i> )	<input type="checkbox"/>
<b>6.2 Separate long-term &amp; short-term parking areas</b>		
BETTER	6.2.1 Provide separate areas for short-term and long-term parking (using signage or physical barriers) to permit access controls and simplify enforcement (i.e. to discourage residents from parking in visitor spaces, and vice versa)	<input type="checkbox"/>