

Engineering

Land/Site
Development

Municipal
Infrastructure

Environmental/
Water Resources

Traffic/
Transportation

Recreational

Planning

Land/Site
Development

Planning Application
Management

Municipal Planning

Urban Design

Expert Witness
(LPAT)

Wireless Industry

Landscape Architecture

Streetscapes &
Public Amenities

Open Space, Parks &
Recreation

Community &
Residential

Commercial &
Institutional

Environmental
Restoration



Fire Station 45

1070 March Road

Development Servicing Study and Stormwater Management Report

**FIRE STATION 45
1075-A MARCH ROAD**

**DEVELOPMENT SERVICING STUDY AND
STORMWATER MANAGEMENT REPORT**

Prepared by:

NOVATECH
Suite 200, 240 Michael Cowpland Drive
Kanata, Ontario
K2M 1P6

August 3, 2022

Ref: R-2022-090
Novatech File No. 122089

August 3, 2022

Morley Hoppner Inc.
1818 Bradley Side Road,
Ottawa, Ontario
K0A 1L0

Attention: Mr. Brian Morley

**Re: Development Servicing Study and Stormwater Management Report
Fire Station 45
1075-A March Road
Novatech File No.: 122089**

Enclosed is a copy of the revised 'Development Servicing Study and Stormwater Management Report' for the proposed Fire Station 45 located at 1070 March Road in the City of Ottawa. This report addresses the approach to site servicing and stormwater management, and it is being submitted in support of a Site Plan Control application.

Please contact the undersigned, should you have any questions or require additional information.

Yours truly,

NOVATECH



François Thauvette, P. Eng.
Senior Project Manager

cc: Julie Candow (City of Ottawa)
Doug Brooks (Hobin Architecture)
Frank Bann (GWAL)

TABLE OF CONTENTS

1.0	INTRODUCTION	1
1.1	Location and Site Description	1
1.2	Pre-Consultation Information	1
1.3	Proposed Development	2
1.4	Reference Material	2
2.0	SITE SERVICING	2
2.1	Sanitary Sewage	2
2.2	Water for Domestic Use and Fire Protection	3
	<i>2.2.1 Water Demands and Watermain Analysis</i>	3
2.3	Storm Drainage and Stormwater Management	6
	<i>2.3.1 Stormwater Management Criteria and Objectives</i>	7
	<i>2.3.2 Maximum Allowable Release Rate</i>	7
	<i>2.3.3 Post-Development Conditions</i>	7
	<i>2.3.3.1 Area A-0 - Uncontrolled Direct Runoff to Buckbean Street</i>	7
	<i>2.3.3.2 Areas A-1 to A-6 - Uncontrolled Flow from Site</i>	7
	<i>2.3.3.3 Area A-7 - Uncontrolled Direct Runoff to March Road</i>	8
	<i>2.3.3.4 Area R-1 – Controlled Flow from Building Roof</i>	8
	<i>2.3.3.5 Summary of Post-Development Flows</i>	9
	<i>2.3.3.6 Stormwater Quality Control</i>	9
3.0	SITE GRADING	9
3.1	Emergency Overland Flow Route	9
4.0	GEOTECHNICAL INVESTIGATIONS	10
5.0	EROSION AND SEDIMENT CONTROL	10
6.0	CONCLUSION	11

LIST OF FIGURES

Figure 1 Aerial Plan

LIST OF APPENDICES

Appendix A: Correspondence

Appendix B: Development Servicing Study Checklist

Appendix C: Sanitary Sewage Calculations, Excerpts from the Copperwood Estates – Site Servicing and SWM Report²

Appendix D: Water Demands, Boundary Conditions, Schematic of the Hydraulic Model, Hydraulic Modelling Results, FUS Calculations

Appendix E: IDF Curves and SWM Calculations, Storm Sewer Design Sheets, Excerpts from the Copperwood Estates – Site Servicing and SWM Report²

Appendix F: Control Flow Roof Drain Information

LIST OF PLANS

General Plan of Services (C1.0)

Grading and Erosion & Sediment Control Plan (C2.0)

Stormwater Management Plan (C3.0)

1.0 INTRODUCTION

Novatech has been retained by *Morley Hoppner Group* to complete the site servicing, grading, and stormwater management design for the proposed Fire Station No. 45 in the City of Ottawa. This report is being submitted in support of a Site Plan Control application.

1.1 Location and Site Description

The 0.837 ha site is located at 1075-A March Road (temporary address), in Kanata North and is currently used as agricultural land, as depicted on Figure 1. The proposed fire station will be located within the larger Copperwood Estates subdivision and the legal description of the subject site is designated as Part 1 of Plan 4R-33375, PIN 04526-1649 City of Ottawa.

Figure 1: Aerial view of the site



1.2 Pre-Consultation Information

An initial pre-consultation meeting was held with the City of Ottawa on August 21, 2019. A subsequent meeting was held on April 22, 2022, at which time the client was advised of the general submission requirements. The Mississippi Valley Conservation Authority (MVCA) was also consulted regarding the proposed development as part of the larger Copperwood Estates subdivision. Based on a review of **O. Reg. 525/98: Approval Exemptions**, a Ministry of the Environment, Conservation and Parks (MECP) Environmental Compliance Approval (ECA) will not be required for the proposed fire station development. Refer to **Appendix A** for a summary of the correspondence related to the proposed development.

1.3 Proposed Development

The proposed development will consist of a 3-bay fire station building with associated paved parking, driveways, and landscaped areas. The proposed building will be serviced by the municipal sanitary sewer, storm sewer and watermain in Buckbean Street.

1.4 Reference Material

- ¹ Geotechnical Investigation – Proposed Fire Station – 1075 March Road (Report No.: PG5321-1, Rev. 1), prepared by Paterson Group on January 20, 2021.
- ² Copperwood Estates (Formerly CU Development) - 1053, 1075 and 1145 March Road – Detailed Site Servicing and Stormwater Management Report (Ref.: R-2021-188), prepared by Novatech on May 4, 2022.

2.0 SITE SERVICING

The objective of the site servicing design is to provide proper sewage outlets, a suitable domestic water supply and to ensure that appropriate fire protection is provided for the proposed development. The servicing criteria, the expected sewage flows, and the water demands are to conform to the requirements of the City of Ottawa municipal design guidelines for sewer and water distribution systems, as described in the Copperwood Estates – Site Servicing and SWM Report². Refer to the subsequent sections of the report for further details.

The City of Ottawa Servicing Study Guidelines for Development Applications requires that a Development Servicing Study Checklist be included to confirm that each applicable item is deemed complete and ready for review by City of Ottawa Infrastructure Approvals. Enclosed in **Appendix B** of the report is a completed checklist.

2.1 Sanitary Sewage

The proposed fire station will be serviced by a new connection to the newly constructed 375mm dia. municipal sanitary sewer in Buckbean Street, which flows into the 600mm dia. trunk sewer in March Road. A maintenance manhole will be provided near the property line for monitoring purposes. Design Criteria from the City of Ottawa Sewer Design Guidelines, Appendix 4-A and subsequent Technical Bulletins were used to calculate the theoretical sewage flows for the proposed fire station. The sanitary sewage calculations are based on the following criteria:

- Average Daily Sewage Flows per Firefighter: 280 L/person/day (full-time staff ~ resident)
- Average Daily Sewage Flows per Firefighter: 75 L/person/day (trainee on training night)
- Average Daily Sewage Flows (Truck Wash): 400 L/vehicle/day (when applicable)
- Institutional Peaking Factor = 1.5
- Infiltration Allowance: 0.33 L/s/ha

The criteria above were compared to the values used in the Copperwood Estates – Site Servicing and SWM Report². The criteria in the report are as follows:

- Average Daily Institutional Sanitary Sewage Flow: 28,000 L/ha/day
- Institutional Peaking Factor = 1.0
- Infiltration Allowance: 0.33 L/s/ha

Table 1 and **Table 1.1** identify the theoretical sanitary flows for the proposed fire station based on the above design criteria.

Table 1: Theoretical Post-Development Sanitary Flows (Staff & Use Basis)

Type of Use	Fire Station (Staff/Truck Washes)	Average Flow (L/s)	Peaking Factor	Peak Flow (L/s)
Staff	8 firefighters + 22 trainees	0.05	1.5	0.07
Truck Wash	3 vehicles	0.01		0.02
Infiltration	0.84 ha	0.28	-	0.28
Total	-	0.34	-	0.37

*Represents rounded values

Table 1.1: Theoretical Post-Development Sanitary Flows (Typical Institutional Use Basis)

Type of Use	Area	Average Flow (L/s)	Peaking Factor	Peak Flow (L/s)
Daily Average Institutional Sewage Flow (28,000 L/ha/day)	0.84 ha	0.27	1.0	0.27
Infiltration (ha)		0.28	-	0.28
Total	-	0.55	-	0.55

*Represents rounded values

As indicated in the tables above, the anticipated sanitary sewage flows from the proposed fire station are considered minimal and within the flows included for this parcel in the Copperwood Estates – Site Servicing and SWM Report². Refer to **Appendix C** for detailed calculations and excerpts from the Copperwood Estates – Site Servicing and SWM Report².

A 150mm dia. sanitary lateral at a minimum slope of 4.0% has a full flow conveyance capacity of 31.8 L/s and will have enough capacity to convey the theoretical sanitary flows from the proposed fire station.

2.2 Water for Domestic Use and Fire Protection

The proposed fire station will be serviced by a new connection to the newly constructed 300mm dia. municipal watermain in Buckbean Street. The Copperwood Estates subdivision is looped off a 400mm dia. feedermain in March Road. The proposed building will be non-sprinklered, however at least three (3) fire hydrants along Buckbean Street will be within 150m of the site. The water meter will be located within the water entry room, with a remote meter on the exterior face of the building. An on-site fire hydrant is being proposed at the back of the fire station for training purposes. Although it is included in the hydraulic analysis, the private on-site hydrant will not technically be required for fire fighting purposes as there are sufficient municipal hydrants nearby.

2.2.1 Water Demands and Watermain Analysis

The theoretical water demands for the proposed development were based on the design criteria from the City of Ottawa Water Distribution Guidelines and subsequent Technical Bulletins. The Fire Underwriters Survey (FUS) method was used to calculate the fire flow based on general assumptions and information provided by the architect. The water demands are calculated based on the following criteria:

- Avg. Daily Water Demand per Firefighter: 280 L/person/day (full-time staff ~ residential)

- Average Daily Water Demand per Firefighter: 75 L/person/day (trainee on training night)
- Average Daily Water Demand (Truck Wash): 400 L/vehicle/day (when applicable)
- Maximum Day Demand = 1.5 x Avg. Day Demand (City Water Table 4.2)
- Peak Hour Demand = 1.8 x Max. Day Demand (City Water Table 4.2)

The criteria above were compared to the values used in the Copperwood Estates – Site Servicing and SWM Report². The criteria in the report are as follows:

- Average Daily Institutional Water Demands: 28,000 L/ha/day
- Maximum Day Demand = 1.5 x Avg. Day Demand (City Water Table 4.2)
- Peak Hour Demand = 1.8 x Max. Day Demand (City Water Table 4.2)

Table 2 and **Table 2.1** identify the theoretical domestic water demands and fire flow requirements for the development based on the above design criteria.

Table 2: Theoretical Post-Development Water Demands (Staff & Use Basis)

Type of Use	Fire Station (Staff/Truck Washes)	Avg. Day Demand (L/s)	Max. Day Demand (L/s)	Peak Hour (L/s)	FUS Fire Flow (L/s)
Staff	8 firefighters + 22 trainees	0.05	0.07	0.12	100
Truck Wash	3 vehicles	0.01	0.02	0.04	
Total*	-	0.06	0.09	0.16	

*Represents rounded values, excluding the (unknown) flow from the on-site hydrant used for training purposes.

Table 2.1: Theoretical Post-Development Water Demands (Typical Institutional Use Basis)

Type of Use	Area (ha)	Avg. Day Demand (L/s)	Max. Day Demand (L/s)	Peak Hour (L/s)
Daily Average Institutional Sewage Flow (28,000 L/ha/day)	0.84	0.27	0.41	0.74

*Represents rounded values, excluding the (unknown) flow from the on-site hydrant used for training purposes

The fire flow requirements were calculated using the Fire Underwriters Survey (FUS). Based on information provided by the architect, the fire flow required for the fire station is expected to be in the order of 100 L/s. Refer to **Appendix D** for detailed calculations, correspondence from the City of Ottawa and excerpts from the Copperwood Estates – Site Servicing and SWM Report².

As discussed with the City of Ottawa, a multi-hydrant approach to firefighting is anticipated to be required to achieve the maximum fire flow. There are at least three (3) new Class AA (blue bonnet) hydrants within 150m of the subject site, two (2) of which are fronting the subject site along Buckbean Street. In addition to these, there will also be a private on-site hydrant (used for training purposes). Based on the City of Ottawa Technical Bulletin ISTB-2018-02, Class AA (blue bonnet) hydrants within 75m have a maximum capacity 95 L/s while hydrants between 75m and 150m have a maximum capacity 63 L/s (at a pressure of 20 PSI). The combined maximum flow from the nearby hydrants exceeds the Max Day + Fire Flow requirement of the proposed development. This multi-hydrant approach to firefighting is in accordance with the City of Ottawa Technical Bulletin ISTB-2018-02. **Table 2.2** summarizes the total theoretical

combined fire flow available from the nearby fire hydrants and compares it to the fire flow demands based on FUS calculations.

Table 2.2: Theoretical Fire Protection Summary Table

Building	Fire Flow Demand (L/s)	Fire Hydrant(s) within 75m (~ 95 L/s each)*	Fire Hydrant(s) within 150m (~ 63 L/s each)	Theoretical Combined Available Fire Flow (L/s)
Fire Station 45	100	3	1	348

Preliminary domestic water demands, and fire flow requirements were provided to the City of Ottawa. **Table 2.3** summarizes preliminary hydraulic analysis results based on municipal watermain boundary conditions provided by the City of Ottawa.

Table 2.3: Hydraulic Boundary Conditions based on Copperwood Estates Report²

Municipal Watermain Boundary Condition	Boundary Condition	Normal Operating Pressure Range (psi)	Anticipated WM Pressure (psi)*
Minimum HGL (Peak Hour Demand)	126.2 m	40 psi (min.)	~ 62.1 psi
Maximum HGL (Max Day Demand)	131.0 m	50 - 70 psi	~ 68.9 psi
HGL (Max Day + Fire Flow)	124.6 m	20 psi (min.)	~ 59.8 psi

*Based on an approximate roadway elevation of 82.5m in Buckbean Street at the service connection. Design pressure = (HGL – watermain elevation) x 1.42197 PSI/m.

The following design criteria were taken from Section 4.2.2 – ‘Watermain Pressure and Demand Objectives’ of the City of Ottawa Design Guidelines for Water Distribution:

- Normal operating pressures are to range between 345 kPa (50 psi) and 483 kPa (70 psi) under Max Day demands
- Minimum system pressures are to be 276 kPa (40 psi) under Peak Hour demands
- Minimum system pressures are to be 140 kPa (20 psi) under Max Day + Fire Flow demands

The hydraulic model EPANET was used to analyzing the performance of the proposed watermain configuration for three (3) theoretical conditions:

- Peak Hour Demand
- Maximum HGL
- Maximum Day + Fire Flow Demand (100 L/s)

A schematic representation of the hydraulic network depicts the node and pipe numbers used in the model. The model indicates that adequate pressure will exist throughout the watermain system under the specified design conditions. **Table 2.4**, **Table 2.5**, and **Table 2.6** summarize the hydraulic model results. Refer to **Appendix D** for City of Ottawa boundary conditions, the hydraulic modeling schematic and modeling results.

Table 2.4: Peak Hour Demand

Operating Condition	Minimum System Pressure	Maximum System Pressure
Peak Hour demand of 0.16 L/s at Node J8 (Building)	A minimum system pressure of 413.9 kPa (60.0 psi) is available at Node J3 (Hyd)	A maximum on-site system pressure of 446.3 kPa (64.7 psi) is available at Nodes J1 and J13 (near connection to municipal WM)

Table 2.5: Maximum HGL

Operating Condition	Minimum System Pressure	Maximum System Pressure
Max Day demand of 0.1 L/s at Node J8 (Building)	A minimum system pressure of 461.1 kPa (66.8 psi) is available at Node J3 (Hyd)	A maximum on-site system pressure of 493.4 kPa (71.5 psi) is available at Nodes J1 and J13 (near connection to municipal WM)

Table 2.6: Maximum Day + Fire Flow Demand

Operating Condition	Minimum System Pressure	Maximum System Pressure
Max Day demands of 0.1 L/s at Node J8 (Building) and 95 L/s at Node J3 (Hyd)	A minimum system pressure of 340.1 kPa (49.3 psi) is available at Node J3 (Hyd)	A maximum on-site system pressure of 419.8 kPa (60.9 psi) is available at Node J13 (near connection to municipal WM)

The model indicates that the municipal watermain in Buckbean Street and the proposed on-site watermain will provide adequate fire flow and system pressures for both 'Max Day + Fire Flow' and 'Peak Hour' conditions.

2.3 Storm Drainage and Stormwater Management

The proposed site will be serviced by a new connection to the new 1200mm dia. storm sewer in Buckbean Street, which flows into the new municipal stormwater management facility (SWMF) immediately to the south. Based on a discussion with the Novatech (Subdivision design) Team, the municipal SWMF will be one of the first things to be constructed, starting in the fall of 2022. The intent is to have the SWMF along with municipal servicing in place along Buckbean Street prior to the occupancy of the new Fire Station. This will ensure the SWMF is operational and able to provide the necessary water quality treatment for the subdivision.

Stormwater runoff from the adjacent property to the northwest (i.e., the future Park and Ride) will be diverted around the subject site towards March Road. The approach for the stormwater management design for the site is discussed in the subsequent sections of the report.

2.3.1 Stormwater Management Criteria and Objectives

The stormwater management (SWM) criteria have been provided during pre-consultation meetings with the City of Ottawa and the MVCA, based on the information contained in the Copperwood Estates – Site Servicing and SWM Report². The SWM criteria and objectives are as follows:

- Maintain existing drainage patterns, where possible.
- Provide a dual drainage system (i.e., minor, and major system flows).
- Control post-development storm flows, up to and including the 100-year design event, to a maximum allowable release rate described in the Copperwood Estates – Site Servicing and SWM Report². This is essentially based on an allowable 5-year design and a runoff coefficient $C=0.85$.
- Ensure that no surface ponding will occur on the paved surfaces (parking stalls and drive aisles) during the 2-year storm event.
- Provide guidelines to ensure that site preparation and construction is in accordance with the current Best Management Practices for Erosion and Sediment Control.

Refer to **Appendix A** for correspondence from the City of Ottawa and to **Appendix E** for excerpts from the Copperwood Estates – Site Servicing and SWM Report².

2.3.2 Maximum Allowable Release Rate

As specified in the Copperwood Estates – Site Servicing and SWM Report², the allowable release rate for the fire station site, including the roadway widening parcel along March Road is approximately 236 L/s. Using a pro-rated area basis, the allowable release rate for the subject site (0.837 ha of a total 0.89 ha) is approximately **221.9 L/s**. The stormwater design of the fire station site has been based on this pro-rated value. Refer to **Appendix E** for detailed calculations and excerpts from the Copperwood Estates – Site Servicing and SWM Report².

2.3.3 Post-Development Conditions

The proposed development will be serviced by a new on-site storm sewer system with a connection to the new 1200mm dia. storm sewer in Buckbean Street, which flows into the new municipal stormwater management facility (SWMF) immediately to the south. Stormwater runoff from the subject site will be directed to various catchbasins, CBMHs and grassed drainage swales. To mitigate the stormwater related impacts due to the increase in imperviousness of the site, stormwater runoff will be attenuated using control flow drains on the proposed building roof. Flows will be controlled for storms up to and including the 100-year design event. Due to the existing grades, runoff from a small portion of the site will sheet drain uncontrolled towards Buckbean Street.

2.3.3.1 Area A-0 - Uncontrolled Direct Runoff to Buckbean Street

The uncontrolled post-development flow from this sub-catchment area was calculated using the Rational Method to be approximately 14.6 L/s during the 5-year design event and 28.2 L/s during the 100-year design event. Refer to **Appendix E** for detailed SWM calculations.

2.3.3.2 Areas A-1 to A-6 - Uncontrolled Flow from Site

The cumulative uncontrolled post-development flow from these sub-catchment areas was calculated using the Rational Method to be approximately 93.0 L/s during the 5-year design

event and 182.4 L/s during the 100-year design event. These values were taken directly from the Storm Sewer Design Sheets prepared for the proposed development. Refer to **Appendix E** for detailed calculations and a copy of the 5-year and 100-year Storm Sewer Design Sheets.

As indicated in the Storm Sewer Design Sheets, the pipe capacity of the on-site storm sewer system will exceed the 5-year design flows, therefore there will be no surface ponding during the 2-year or the 5-year design storms. During the 100-year design storm the pipe capacity will restrict the site flows slightly, however there will be no surface ponding as minor surcharging will be contained within the on-site storm sewer system.

2.3.3.3 Area A-7 - Uncontrolled Direct Runoff to March Road

The uncontrolled post-development flow from this sub-catchment area was calculated using the Rational Method to be approximately 2.7 L/s during the 5-year design event and 5.7 L/s during the 100-year design event. Refer to **Appendix E** for detailed SWM calculations.

2.3.3.4 Area R-1 – Controlled Flow from Building Roof

The post-development flow from this sub-catchment area will be attenuated using Watts adjustable ‘Accutrol’ control flow roof drains (RD 1 and RD 2) prior to being directed to the proposed on-site storm sewer system. The small canopy roof on the north side of the building (RD3) is too small to require a controlled flow roof drain.

Table 3 summarizes the post-development design flows from this sub-catchment area as well as the type of roof drains, the maximum anticipated ponding depths, storage volumes required and storage volumes provided for both the 5-year and the 100-year design events.

Table 3: Controlled Flow Roof Drains

Roof Drain ID & Drainage Area (ha)	Number of Roof Drains	Watts Roof Drain Model ID (Weir Opening)	Total Controlled Flow (L/s)		Approximate Ponding Depth Above Drains (m)		Storage Volume Required (m ³)		Max. Storage Available (m ³)
			1:5 Year	1:100 Year	1:5 Year	1:100 Year	1:5 Year	1:100 Year	
RD 1+2 (0.049 ha)	2	RD-100-A-ADJ (Fully Exposed)	2.14	2.78	0.09	0.12	8.0	17.9	29.3
RD 3 (0.001 ha)	1	-	0.26*	0.50*	-	-	-	-	-
Total Roof (0.050 ha)	3	-	2.40	3.30	-	-	8.0	17.9	29.3

Table represents rounded values. * RD3 does not require controlled roof drain as the area is too small.

Refer to **Appendix E** for detailed SWM calculations and to **Appendix F** for detailed control flow roof drain information. As indicated in the table above, the building roof will provide sufficient storage for both the 5-year and 100-year design events.

2.3.3.5 Summary of Post-Development Flows

Table 3.1 compares the 5-year and 100-year design event post-development site flows from the proposed development to the maximum allowable release rate specified in the Copperwood Estates – Site Servicing and SWM Report².

Table 3.1: Stormwater Flow Comparison Table

Design Event	Drainage Areas A-0 to A-7 and R-1					
	Pre-Dev. Conditions	Post-Development Conditions				
	Max Release Rate (L/s)	A-0 Direct Runoff to Buckbean Street (L/s)	A-1 to A-6 Uncontrolled Flow (L/s)	A-7 Direct Runoff to March Road (L/s)	R-1 Controlled Flow (L/s)	Total Flow (L/s)
5-Yr	221.9	14.6	93.0	2.7	2.4	112.7
100-Yr		28.2	182.4	5.7	3.3	219.6

As indicated in the table above, the 5-year and 100-year post-development flows will be less than the maximum allowable release rate for the site. Refer to **Appendix E** for detailed SWM calculations.

2.3.3.6 Stormwater Quality Control

The subject site is located within the jurisdiction of the Mississippi Valley Conservation Authority (MVCA). Based on a review of the Copperwood Estates – Site Servicing and SWM Report², the municipal stormwater management facility (SWMF) across the street will provide the required 'Enhanced' Level of Protection (i.e.: 80% TSS removal) for the subject site. Consequently, on-site stormwater quality control measures will not be required.

3.0 SITE GRADING

The existing site slopes approximately 2m from west to east. The finished floor elevation (FFE) of the fire station has been set at 83.50m, based on practical site entrance slopes off Buckbean Street. The surrounding elevation of the future 'Park and Ride' block (to the north and west) has not been designed yet, however the existing grades are generally higher than the proposed site. As such temporary diversion swales (by others) are being proposed along the north and west property lines (on the neighbouring property) to prevent off-site flows from draining onto the subject site. Furthermore, perimeter berms are being proposed to ensure off-site flows will be directed towards March Road until such time as the future Park and Ride is constructed. Refer to the enclosed Grading and ESC Plan (C2.0) for details.

3.1 Emergency Overland Flow Route

In the case of a major rainfall event exceeding the design storms provided for, the stormwater located within the proposed site will overflow towards the lower downstream sub-catchment areas and ultimately overflow towards Buckbean Street and March Road. Furthermore, the emergency spill point elevations within the site have been set at least 0.30m below the lowest building openings. The emergency overland flow routes are shown on the enclosed Grading and ESC Plan (C2.0).

4.0 GEOTECHNICAL INVESTIGATIONS

Paterson Group prepared a Geotechnical Investigation Report for the proposed development. Refer to the Geotechnical Report¹ for subsurface conditions, construction recommendations and geotechnical inspection requirements.

5.0 EROSION AND SEDIMENT CONTROL

To mitigate erosion and to prevent sediment from entering the storm sewer system, temporary erosion and sediment control measures will be implemented on-site during construction in accordance with the Best Management Practices for Erosion and Sediment Control. This includes the following temporary measures:

- Catch basin inserts (sediments sacks) will be placed within nearby catch basins and manholes and they will remain in place until vegetation has been established and construction is completed.
- Silt fencing will be placed per OPSS 577 and OPSD 219.110 where appropriate, along the surrounding construction limits.
- Mud mats will be installed at the site entrances.
- Street sweeping and cleaning will be performed, as required, to suppress dust and to provide safe and clean roadways adjacent to the construction site.
- On-site dewatering is to be directed to a sediment trap and/or gravel splash pad and discharged safely to an approved outlet as directed by the engineer.
- Any stockpiled material will be properly managed to prevent those materials from entering the sewer system and/or the downstream ditch or watercourse.

The temporary erosion and sediment control measures will be implemented prior to construction and will remain in place during all phases of construction. Regular inspection and maintenance of the erosion control measures will be undertaken.

6.0 CONCLUSION

This report has been prepared in support of Site Plan Control application for the proposed Fire Station 45 in the City of Ottawa. The conclusions are as follows:

- The proposed development will be serviced by the municipal watermain, sanitary and storm sewers in Buckbean Street.
- The building will be non-sprinklered. The nearby municipal fire hydrants along Buckbean Street will provide the necessary fire protection.
- The stormwater management design for the fire station will include on-site quantity control measures prior to releasing flows from the site. The stormwater quantity control measures will meet the requirements of the City of Ottawa, as described in the Copperwood Estates – Site Servicing and SWM Report². Stormwater quality control measures will be provided by the municipal SWMF across the street.
 - Post-development flow from the main building roof (area R-1) will be attenuated using control flow roof drains.
 - The total post-development flow to the site will be approximately 112.7 L/s during the 5-year event and 219.6 L/s during the 100-year event, all less than the maximum allowable release rate of 221.9 L/s described in the Copperwood Estates – Site Servicing and SWM Report².
 - Erosion and sediment controls are to be provided during construction.
- Regular inspection and maintenance of the storm sewer system and control flow roof drains is recommended to ensure that the storm drainage system is clean and operational.

It is recommended that the proposed site servicing and stormwater management design be approved for implementation.

NOVATECH

Prepared by:



François Thauvette, P. Eng.
Senior Project Manager

APPENDIX A
Correspondence

1075 March Road
Pre-Consultation Meeting Minutes

Location: Room 4102E, City Hall
Date: August 21, 11am – 12pm

Attendee	Role
Stream Shen	Planner
Julie Candow	Project Manager (Engineer)
Rosanna Baggs	Project Manager (Transportation)
Matthew Hayley	Environmental Planner
Samantha Gatchene	Planning Assistant
Christine Hogan	Analyst (Asset Management)
Michael Lewis	Senior Engineer (Asset Management)
Peter Dodsworth	Program Manager (Design & Construction)
Shawn Lynch	Project Manager (Design & Construction)
Nathan Adams	Program Manager (Fire Services)

Comments from Applicant

1. The applicant is proposing a 3-bay fire station (Station 45) within the CU Development subdivision located at 1075 March Road (Block 309).
2. A location area study completed in 2015 identified the station location.
3. The proposed station will be a composite station and will host 7 career fire fighters (per shift) and up to 25 volunteers.
4. Two access are proposed onto Street 1; an access for returning fire trucks and regular vehicles on the eastern edge of the site and an access for fire trucks exiting onto Street 1 further west.
5. Finance: 2 million dollars will be allocated for 2020 and the remaining money will be allocated for 2021. The plan is to break grounds in 2021.

Planning Comments

1. This is a pre-consultation for a Site Plan Control Application, Standard, Staff Approval. Application form, timeline and fees can be found [here](#).
2. Draft approval for the CU subdivision is expected in Fall 2019 and Spring 2020 for the Servicing and subsequently Registering of Phase 1. The fire station will be

available for purchase as part of phase 1 registration. For further questions on the timing of purchase and infrastructure availability, please contact Greg Winters at g.winters@novatech-eng.com or by telephone at 613-254-9643 Ext. 241.

3. Once, the subdivision receives draft approval, the block will be zoned Minor Institutional Zone (I1A) to permit the fire station. Please confirm whether any deviation from this proposed zoning is required so that we may create any necessary exception at the zoning by-law amendment stage.
4. Please ensure that all the proposed light fixture contain sharp cut-off and no light spillage on adjacent lands.
5. Please consult the Ward Councillors prior to application submission. Please consult both Councillor Jenna Sudds and Councillor El-Chantiry as the site is currently located in Ward 5, but Councillor Sudds is leading the coordination given it is an urban subdivision.

Engineering Comments

1. The Stormwater Management Criteria for the subject site is to be based on the following:
 - i. The 100-yr post development allowable storm release rate shall be controlled to 219 L/s, as per Novatech's *1053, 1075 and 1145 March Road Site Servicing and Stormwater Management Report* (allowable storm release rate to be confirmed at Site Plan Control with the latest revision of Novatech's report).
 - ii. Onsite storm runoff, in excess of the allowable release rate, and up to the 100-yr storm event must be detained on site.
 - iii. Quantity control to be provide by the adjacent SWM Pond 1, to be constructed as part of the Claridge / Uniform subdivision. Onsite quality control will not be required (provided that the adjacent SWM Pond 1 is fully operational at the time of Site Plan Approval).
2. The proposed sanitary, storm and water service shall outlet to Street 1. The applicant is encouraged to coordinate with Novatech (engineering consultant for Claridge/Uniform subdivision) to discuss the timing of Phase 1 construction (inclusive of Street 1 and SWM Pond 1) as well as the installation of service stubs for the subject property, to avoid unnecessary road cuts in the future.
3. The existing borehole onsite estimates a bedrock depth of approximately 4.2m. Additional boreholes will be required within the subject property to better predict

the bedrock elevations throughout the site. The bedrock elevation may dictate the preferred location of the service laterals.

4. The subject property has an elevation difference of approximately 2m. The proposed grading onsite may require the use of retaining walls or landscape terracing (maximum 3:1) to tie in with existing grades at the property limits.
5. Water Boundary condition requests must include the location of the service and the expected loads required by the proposed development. Please provide the following information:
 - i. Location of service (Street 1)
 - ii. Type of development and the amount of fire flow required (as per FUS, 1999).
 - iii. Average daily demand: ___ l/s.
 - iv. Maximum daily demand: ___ l/s.
 - v. Maximum hourly daily demand: ___ l/s.
6. An MECP Environmental Compliance Approval is not anticipated to be required for the subject site.

Should you have any questions or require additional information, please contact me directly at (613) 580-2424, x13850 or by email at Julie.Candow@ottawa.ca.

Transportation Comments

1. Follow Traffic Impact Assessment Guidelines
 - o Traffic Impact Assessment will be required.
 - o Start this process asap.
 - o Applicant advised that their application will not be deemed complete until the submission of the draft step 1-4, including the functional draft RMA package (if applicable) and/or monitoring report (if applicable).
2. ROW protection on March Rd between Urban Limit and Terry Fox is 44.5m even (Note: Subject to unequal widenings outlined in March Road ESR). Corner triangles as per OP Annex 1 - Road Classification and Rights-of-Way at the following locations on the final plan will be required (measure on the property line/ROW protected line; no structure above or below this triangle):
 - o Collector Road to Arterial Road: 5 metre x 5 metres
3. Sight triangle as per Zoning by-law is 6 metre x 6 metre measure on the curb line.
4. Noise Impact Studies required for the following:
 - o Road
5. Recommended to have the general access as far from the intersection as possible; flip the building and parking. TAC requires 55m between intersection and access.

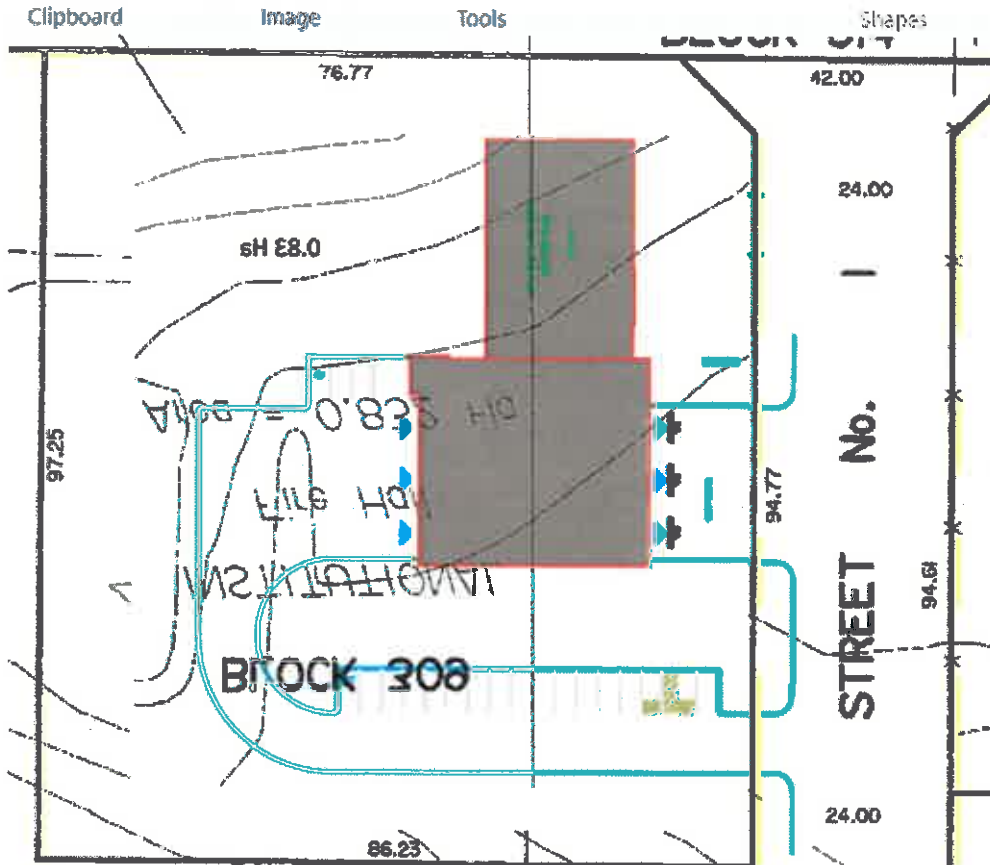

6. AODA standards required; see attached checklist for guidance.
7. On site plan:
 - o Show all details of the roads abutting the site up to and including the opposite curb; include such items as pavement markings, accesses and/or sidewalks.
 - o Turning templates will be required for all accesses showing the largest vehicle to access the site; required for internal movements and at all access (entering and exiting and going in both directions). Show on separate drawing
 - o Show all curb radii measurements; ensure that all curb radii are reduced as much as possible
 - o Show lane/aisle widths.
 - o Sidewalk is to be continuous across access as per City Specification 7.1.
 - o Grey out any area that will not be impacted by this application.

Environment Comments

1. Please plant native species.

2. The site currently contains category 3 turtle habitat. The Kanata North land owner's group is currently pursuing an overall benefit permit. If the fire station is developed following the acceptance of the permit, no further action or study is required.

Forestry Comments

1. Depending on whether there are existing trees on-site, a Tree Conservation Report (TCR) may be required to review along with the suite of other plans/reports required by the City; an approved TCR is a requirement of Site Plan or Plan of Subdivision approval
2. Any removal of privately-owned trees 10cm or larger in diameter require a tree permit issued under the Urban Tree Conservation Bylaw; the permit is based on the approved TCR
3. In this case, the TCR may be combined with the LP
4. The TCR must list all trees on site by species, diameter and health condition.
5. The TCR must address all trees with a critical root zone that extends into the developable area.
6. If trees are to be removed, the TCR must clearly show where they are and document the reason they can not be retained
7. All retained trees must also be shown and all retained trees within the area impacted by the development process must be protected as per the City guidelines listed on Ottawa.ca
8. Trees with a trunk that crosses/touches a property line are considered co-owned by both property owners; permission from the adjoining property owner must be obtained prior to the removal of co-owned trees
9. The City does encourage the retention of healthy trees wherever possible; please ask your design/planning team to find opportunities for retention wherever possible if the trees are healthy and will contribute to the design/function of the site. For more information on the process or help with tree retention options, contact Mark Richardson mark.richardson@ottawa.ca
10. The removal of City-owned trees will require the permission of Forestry Services who will also review the submitted TCR; note that Forestry Services may ask for compensation for any City-owned tree that has to be removed.

Please refer to the links to "[Guide to preparing studies and plans](#)" and [fees](#) for general information. Additional information is available related to [building permits, development](#)

charges, and the Accessibility Design Standards. Be aware that other fees and permits may be required, outside of the development review process. You may obtain background drawings by contacting informationcentre@ottawa.ca.

These pre-con comments are valid for one year. If you submit a development application(s) after this time, you may be required to meet for another pre-consultation meeting and/or the submission requirements may change. You are as well encouraged to contact us for a follow-up meeting if the plan/concept will be further refined.

Please contact me at stream.shen@ottawa.ca or at 613-580-2424 extension 24488 if you have any questions.

Sincerely,

A handwritten signature in black ink, appearing to read 'Stream Shen', written over a horizontal line.

Stream Shen MCIP RPP
Planner II
Development Review - West

APPENDIX B
Development Servicing Study Checklist

Servicing study guidelines for development applications

4. Development Servicing Study Checklist

The following section describes the checklist of the required content of servicing studies. It is expected that the proponent will address each one of the following items for the study to be deemed complete and ready for review by City of Ottawa Infrastructure Approvals staff.

The level of required detail in the Servicing Study will increase depending on the type of application. For example, for Official Plan amendments and re-zoning applications, the main issues will be to determine the capacity requirements for the proposed change in land use and confirm this against the existing capacity constraint, and to define the solutions, phasing of works and the financing of works to address the capacity constraint. For subdivisions and site plans, the above will be required with additional detailed information supporting the servicing within the development boundary.

4.1 General Content

- Executive Summary (for larger reports only).
- Date and revision number of the report.
- Location map and plan showing municipal address, boundary, and layout of proposed development.
- Plan showing the site and location of all existing services.
- Development statistics, land use, density, adherence to zoning and official plan, and reference to applicable subwatershed and watershed plans that provide context to which individual developments must adhere.
- Summary of Pre-consultation Meetings with City and other approval agencies.
- Reference and confirm conformance to higher level studies and reports (Master Servicing Studies, Environmental Assessments, Community Design Plans), or in the case where it is not in conformance, the proponent must provide justification and develop a defensible design criteria.
- Statement of objectives and servicing criteria.
- Identification of existing and proposed infrastructure available in the immediate area.
- Identification of Environmentally Significant Areas, watercourses and Municipal Drains potentially impacted by the proposed development (Reference can be made to the Natural Heritage Studies, if available).
- Concept level master grading plan to confirm existing and proposed grades in the development. This is required to confirm the feasibility of proposed stormwater management and drainage, soil removal and fill constraints, and potential impacts to neighbouring properties. This is also required to confirm that the proposed grading will not impede existing major system flow paths.
- Identification of potential impacts of proposed piped services on private services (such as wells and septic fields on adjacent lands) and mitigation required to address potential impacts.
- Proposed phasing of the development, if applicable.

- Reference to geotechnical studies and recommendations concerning servicing.

- All preliminary and formal site plan submissions should have the following information:
 - Metric scale

 - North arrow (including construction North)

 - Key plan

 - Name and contact information of applicant and property owner

 - Property limits including bearings and dimensions

 - Existing and proposed structures and parking areas

 - Easements, road widening and rights-of-way

 - Adjacent street names

4.2 Development Servicing Report: Water

- Confirm consistency with Master Servicing Study, if available
- Availability of public infrastructure to service proposed development
- Identification of system constraints
- Identify boundary conditions
- Confirmation of adequate domestic supply and pressure
- Confirmation of adequate fire flow protection and confirmation that fire flow is calculated as per the Fire Underwriter's Survey. Output should show available fire flow at locations throughout the development.
- Provide a check of high pressures. If pressure is found to be high, an assessment is required to confirm the application of pressure reducing valves.
- Definition of phasing constraints. Hydraulic modeling is required to confirm servicing for all defined phases of the project including the ultimate design
- Address reliability requirements such as appropriate location of shut-off valves
- Check on the necessity of a pressure zone boundary modification.
- Reference to water supply analysis to show that major infrastructure is capable of delivering sufficient water for the proposed land use. This includes data that shows that the expected demands under average day, peak hour and fire flow conditions provide water within the required pressure range

- Description of the proposed water distribution network, including locations of proposed connections to the existing system, provisions for necessary looping, and appurtenances (valves, pressure reducing valves, valve chambers, and fire hydrants) including special metering provisions.
- Description of off-site required feeder mains, booster pumping stations, and other water infrastructure that will be ultimately required to service proposed development, including financing, interim facilities, and timing of implementation.
- Confirmation that water demands are calculated based on the City of Ottawa Design Guidelines.
- Provision of a model schematic showing the boundary conditions locations, streets, parcels, and building locations for reference.

4.3 Development Servicing Report: Wastewater

- Summary of proposed design criteria (Note: Wet-weather flow criteria should not deviate from the City of Ottawa Sewer Design Guidelines. Monitored flow data from relatively new infrastructure cannot be used to justify capacity requirements for proposed infrastructure).
- Confirm consistency with Master Servicing Study and/or justifications for deviations.
- Consideration of local conditions that may contribute to extraneous flows that are higher than the recommended flows in the guidelines. This includes groundwater and soil conditions, and age and condition of sewers.
- Description of existing sanitary sewer available for discharge of wastewater from proposed development.
- Verify available capacity in downstream sanitary sewer and/or identification of upgrades necessary to service the proposed development. (Reference can be made to previously completed Master Servicing Study if applicable)
- Calculations related to dry-weather and wet-weather flow rates from the development in standard MOE sanitary sewer design table (Appendix 'C') format.
- Description of proposed sewer network including sewers, pumping stations, and forcemains.
- Discussion of previously identified environmental constraints and impact on servicing (environmental constraints are related to limitations imposed on the development in order to preserve the physical condition of watercourses, vegetation, soil cover, as well as protecting against water quantity and quality).
- Pumping stations: impacts of proposed development on existing pumping stations or requirements for new pumping station to service development.
- Forcemain capacity in terms of operational redundancy, surge pressure and maximum flow velocity.
- Identification and implementation of the emergency overflow from sanitary pumping stations in relation to the hydraulic grade line to protect against basement flooding.
- Special considerations such as contamination, corrosive environment etc.

4.4 Development Servicing Report: Stormwater Checklist

- Description of drainage outlets and downstream constraints including legality of outlets (i.e. municipal drain, right-of-way, watercourse, or private property)
- Analysis of available capacity in existing public infrastructure.
- A drawing showing the subject lands, its surroundings, the receiving watercourse, existing drainage patterns, and proposed drainage pattern.
- Water quantity control objective (e.g. controlling post-development peak flows to pre-development level for storm events ranging from the 2 or 5 year event (dependent on the receiving sewer design) to 100 year return period); if other objectives are being applied, a rationale must be included with reference to hydrologic analyses of the potentially affected subwatersheds, taking into account long-term cumulative effects.
- Water Quality control objective (basic, normal or enhanced level of protection based on the sensitivities of the receiving watercourse) and storage requirements.
- Description of the stormwater management concept with facility locations and descriptions with references and supporting information.
- Set-back from private sewage disposal systems.
- Watercourse and hazard lands setbacks.
- Record of pre-consultation with the Ontario Ministry of Environment and the Conservation Authority that has jurisdiction on the affected watershed.
- Confirm consistency with sub-watershed and Master Servicing Study, if applicable study exists.
- Storage requirements (complete with calculations) and conveyance capacity for minor events (1:5 year return period) and major events (1:100 year return period).
- Identification of watercourses within the proposed development and how watercourses will be protected, or, if necessary, altered by the proposed development with applicable approvals.
- Calculate pre and post development peak flow rates including a description of existing site conditions and proposed impervious areas and drainage catchments in comparison to existing conditions.
- Any proposed diversion of drainage catchment areas from one outlet to another.
- Proposed minor and major systems including locations and sizes of stormwater trunk sewers, and stormwater management facilities.
- If quantity control is not proposed, demonstration that downstream system has adequate capacity for the post-development flows up to and including the 100 year return period storm event.
- Identification of potential impacts to receiving watercourses
- Identification of municipal drains and related approval requirements.
- Descriptions of how the conveyance and storage capacity will be achieved for the development.
- 100 year flood levels and major flow routing to protect proposed development from flooding for establishing minimum building elevations (MBE) and overall grading.

- Inclusion of hydraulic analysis including hydraulic grade line elevations.
- Description of approach to erosion and sediment control during construction for the protection of receiving watercourse or drainage corridors.
- Identification of floodplains – proponent to obtain relevant floodplain information from the appropriate Conservation Authority. The proponent may be required to delineate floodplain elevations to the satisfaction of the Conservation Authority if such information is not available or if information does not match current conditions.
- Identification of fill constraints related to floodplain and geotechnical investigation.

4.5 Approval and Permit Requirements: Checklist

The Servicing Study shall provide a list of applicable permits and regulatory approvals necessary for the proposed development as well as the relevant issues affecting each approval. The approval and permitting shall include but not be limited to the following:

- Conservation Authority as the designated approval agency for modification of floodplain, potential impact on fish habitat, proposed works in or adjacent to a watercourse, cut/fill permits and Approval under Lakes and Rivers Improvement Act. The Conservation Authority is not the approval authority for the Lakes and Rivers Improvement Act. Where there are Conservation Authority regulations in place, approval under the Lakes and Rivers Improvement Act is not required, except in cases of dams as defined in the Act.
- Application for Certificate of Approval (CofA) under the Ontario Water Resources Act.
- Changes to Municipal Drains.
- Other permits (National Capital Commission, Parks Canada, Public Works and Government Services Canada, Ministry of Transportation etc.)

4.6 Conclusion Checklist

- Clearly stated conclusions and recommendations
- Comments received from review agencies including the City of Ottawa and information on how the comments were addressed. Final sign-off from the responsible reviewing agency.
- All draft and final reports shall be signed and stamped by a professional Engineer registered in Ontario

APPENDIX C

**Sanitary Sewage Calculations,
Excerpts from the Copperwood Estates – Site Servicing and SWM Report²**

FIRE STATION 45

Sanitary Flows(Staff and Use)

Site Area	0.84	ha
Average Sanitary Flow - <i>Staff</i> (280 L/person/day)	8	0.03
Average Sanitary Flow - <i>Trainee</i> (75 L/person/day)	22	0.02
Truck Washing (400 L/truck/wash)	3	0.01
Average Daily Flow		0.06 L/s
Peaking Factor - <i>Commercial</i>		1.5
Peak Sanitary Flow		0.09 L/s
Infiltration Allowance		0.33 L/s/ha
Peak Extraneous Flows		0.28 L/s
Total Peak Sanitary Flow		0.37 L/s

FIRE STATION 45

Sanitary Flows (Typical Institutional Use Basis)

Site Area	0.84 ha
Average Sanitary Flow - <i>Commercial</i>	28,000 L/ha/day
Average Daily Flow	0.27 L/s
Peaking Factor - <i>Commercial</i>	1.0
Peak Sanitary Flow	0.27 L/s
Infiltration Allowance	0.33 L/s/ha
Peak Extraneous Flows	0.28 L/s
Total Peak Sanitary Flow	0.55 L/s

SANITARY SEWER DESIGN SHEET
1053, 1075 and 1145 March Road
Copperwood Estate- Phase 1



PROJECT # : 116132
 DESIGNED BY : MM/SAZ
 CHECKED BY : DDB
 DATE PREPARED : 6-Jun-18
 DATE REVISED : 8-May-19
 DATE REVISED : 20-Apr-20
 DATE REVISED : 23-Dec-21
 DATE REVISED : 4-May-22

LOCATION					RESIDENTIAL										COMMERCIAL / INSTITUTIONAL / PARK					INFILTRATION			FLOW		PROPOSED SEWER										
STREET	FROM MH	TO MH	Area ID	Total Area (ha.)	INDIVIDUAL				CUMULATIVE				AREA (ha.)	Accu. AREA (ha.)	AREA (ha.)	Accu. AREA (ha.)	AREA (ha.)	Accu. AREA (ha.)	PEAK COMM/INST/PARK FLOW Qc(p) (L/s)	Total Area (ha.)	Accu. Total AREA (ha.)	PEAK EXTRAN. FLOW Q(i) (L/s)	PEAK DESIGN FLOW Q(d) (L/s)	LENGTH (m)	PIPE SIZE (mm)	PIPE ID (mm)	TYPE OF PIPE	GRADE %	CAPACITY (L/s)	FULL FLOW VELOCITY (m/s)	Opeak/ Gcap	d/ D _{min}	Actual Velocity		
					Single Units	Semi-Town Units	Multi-Unit Towns	Multi-Unit Apartment	Population (in 1000's)	AREA (ha.)	Population (in 1000's)	AREA (ha.)																						PEAK FACTOR M	PEAK POPULATION FLOW Qr(p) (L/s)
FUTURE BLOCK / EXISTING LANDS ACCOUNTED FOR INCLUDING BLOCK 315	FUT / EX	1407		0.00																															
Easement - Park&Ride	1407	1409	B77	3.33					0.00	0.113	3.33	0.392	9.02	3.4	4.35	0.00		4.34	0.00	1.41	3.33	13.36	4.41	10.16	103.3	200	203.20	DR 35	0.44	22.7	0.70	44.8%			
Easement - Park&Ride	1409	1215		0.00			25	25	0.00	0.000		0.392	9.02	3.4	4.35	0.00		4.34	0.00	1.41	0.00	13.36	4.41	10.16	97.2	200	203.20	DR 35	0.44	22.7	0.70	44.8%			
Street 1	1215	1217	B68	0.13					0.000	0.13		2.428	38.60	3.0	23.72	0.00		4.34	2.22	1.50	0.13	45.16	14.90	40.13	69.9	375	381.00	DR 35	0.75	158.4	1.39	25.3%	0.34	1.15	
Street 1	1217	1219	B69	0.14					0.000	0.14		2.428	38.74	3.0	23.72	0.00		4.34	2.22	1.50	0.14	45.30	14.95	40.17	27.1	375	381.00	DR 35	0.75	158.4	1.39	25.4%	0.34	1.15	
Street 1	1219	1221							0.000	0.00		2.428	38.74	3.0	23.72	0.00		4.34	2.22	1.50	0.00	45.30	14.95	40.17	28.2	375	381.00	DR 35	0.76	159.5	1.40	25.2%	0.34	1.16	
Street 1	1221	1223	B78	1.10					0.000	0.27		2.428	39.01	3.0	23.72	0.00	0.83	5.17	2.22	1.77	1.10	46.40	15.31	40.80	99.1	375	381.00	DR 35	0.75	158.4	1.39	25.8%	0.34	1.15	
Total Flows - Outlet 1										0.000	0.27		2.428	39.01	3.0	23.72	0.00				1.77	1.10	46.40	15.31	40.80									0.00	
Outlet 2 - Street 10 and March Road																																			
Street 10	909	911	A1	1.05				42	0.076	1.05		0.076	1.05	3.6	0.89	0.00		0.00	0.00	0.00	1.05	1.05	0.35	1.23	82.0	250	254.00	DR 35	1.84	86.4	1.71	1.4%			
Street 10	911	913	A2	3.57				28	0.050	0.50		0.126	1.55	3.6	1.46	0.00	3.07	3.07	0.00	0.99	3.57	4.62	1.52	3.98	45.3	250	254.00	DR 35	1.94	86.4	1.71	4.6%			
Street 10	913	915	A3	0.00					0.000	0.00		0.126	1.55	3.6	1.46	0.00		3.07	0.00	0.99	0.00	4.62	1.52	3.98	47.4	250	254.00	DR 35	1.71	81.1	1.60	4.9%			
Street 10	915	917	A4	0.25					0.000	0.00		0.126	1.55	3.6	1.46	0.25	0.25	3.07	0.00	1.08	0.25	4.87	1.61	4.14	75.7	250	254.00	DR 35	1.98	87.3	1.72	4.7%			
Street 10	917	919	A5	2.38					0.000	0.00		0.126	1.55	3.6	1.46	0.00		3.07	0.00	1.84	2.38	7.23	2.39	5.69	74.9	250	254.00	DR 35	2.15	91.0	1.80	6.2%			
Total Flows - Outlet 2										0.000	0.00		0.126	1.55	3.6	1.46	0.25				1.84	2.38	7.23	2.39	5.69										

Notes:
 1. Q(d) = Qr(p) + Q(i) + Qc(p)
 2. Q(i) = 0.33 L/sec/ha
 3. Qc(p) = (A * q) / 3600
Definitions:
 Q(d) = Design Flow (L/sec)
 Qr(p) = Population Flow (L/sec), Residential
 Q(i) = Extraneous Flow (L/sec)
 Qc(p) = Population Flow (L/sec), Commercial/Institutional/Park

P = Population (3.4 persons per single unit, 2.7 persons per townhouse unit, 2.7 persons per multi-unit townhouse unit, 1.8 persons per multi-unit apartment)
 q = Average per capita flow = 280 L/cap/day - Residential
 q = Average per gross ha. flow = 35000 L/gross ha/day - Light Industrial
 q = Average per gross ha. flow = 28000 L/gross ha/day - Commercial/Institutional
 q = Average per gross ha. flow = 3700 L/gross ha/day - Park (20L/day/person, 185 persons/ha - as per Appendix 4-A of the City of Ottawa Sewer Design Guidelines)
 M = Harmon Formula (maximum of 4.0), K = Correction Factor = 0.8
 Min pipe size: 200mm @ min. slope 0.32%
 Mannings n = 0.013
 Pf = Peak factor (Commercial/Institutional/Park) = 1.0 (less than 20% of total contributing areas), 1.5 (if area is 20% or greater of total contributing area)

*Assumes existing single lot along roadway will ultimately become 2 single units.
 **Assumes north half of property is 50% towns and 50% singles at same density as CU lands (25 singles/ha, 47 towns/ha), south half of property assumed to be multi unit residential at same density as CU lands (62.8units/ha).

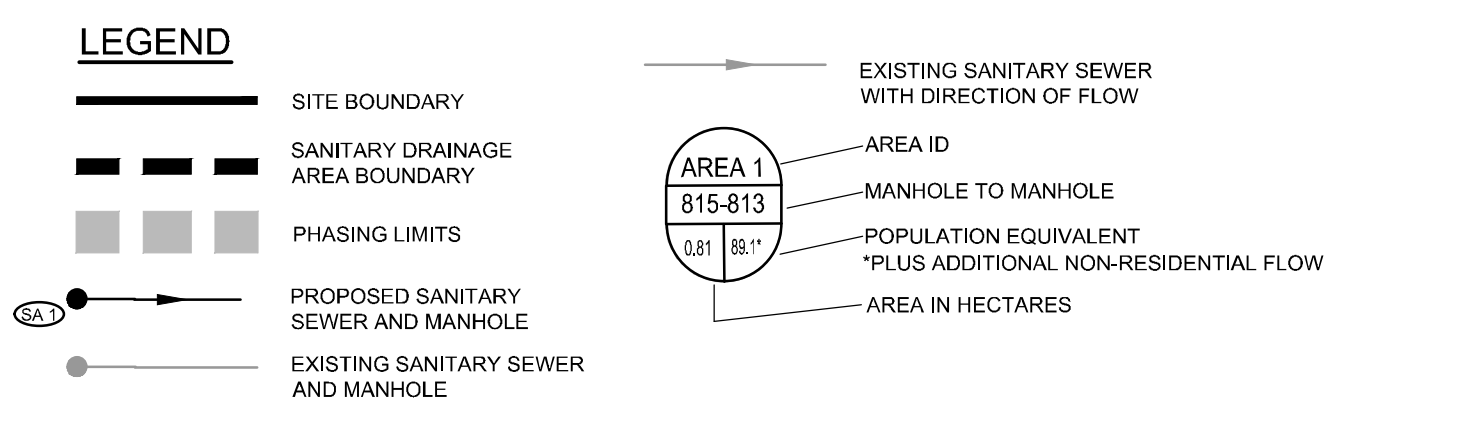
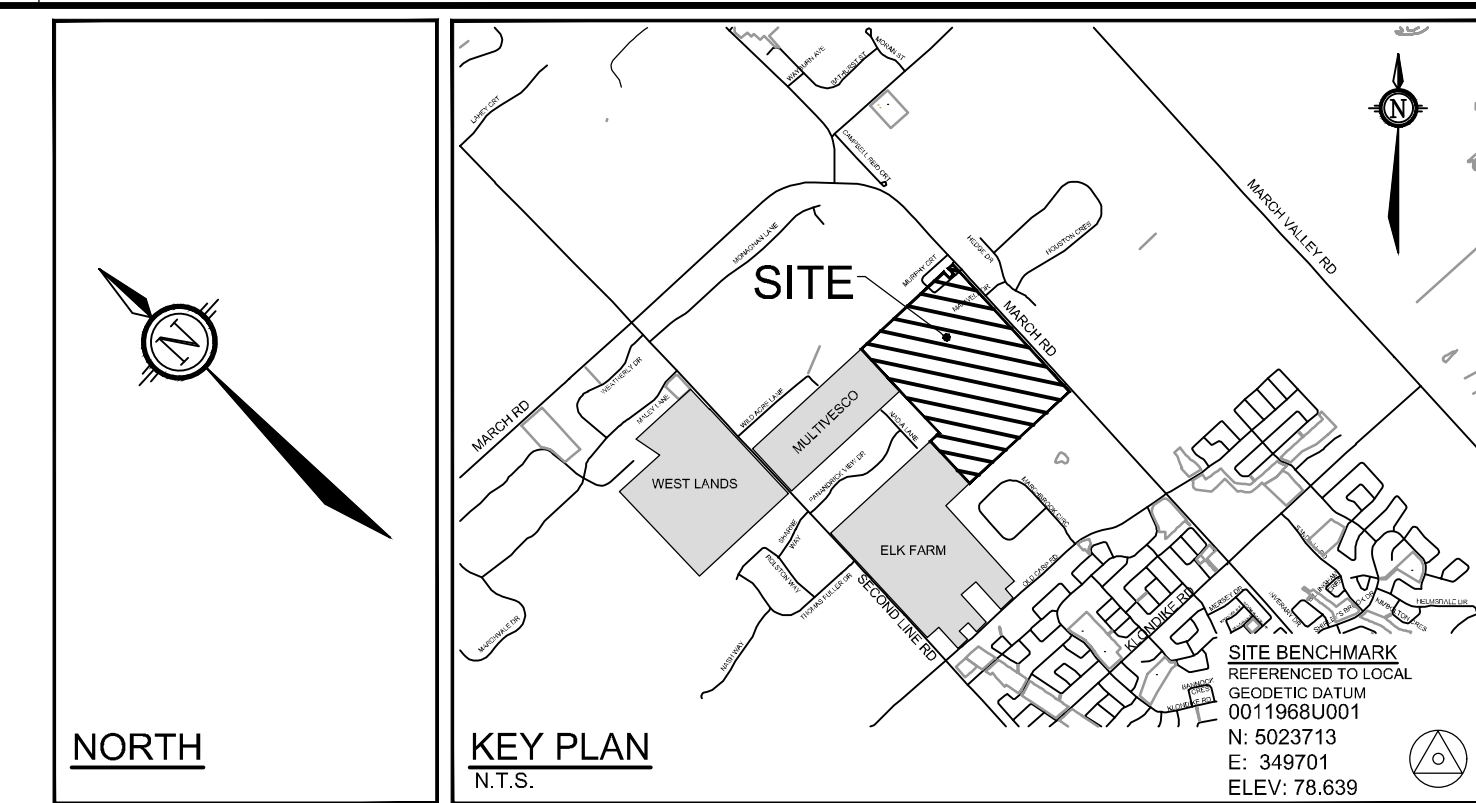
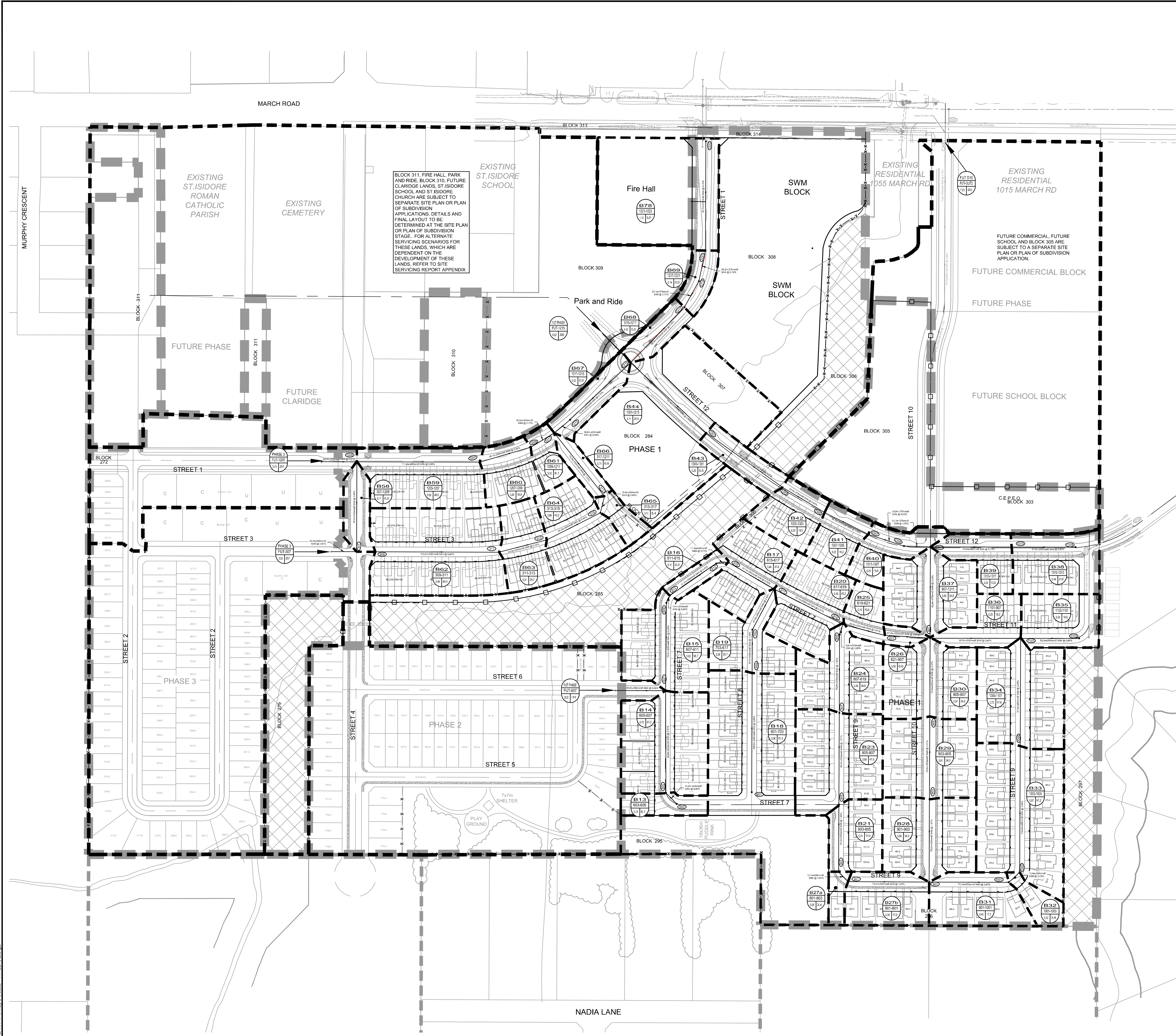

C:\Users\116132\OneDrive\116132\SAN.dwg SAN, P1, 1 May 04, 2022 - 11:15am, ezmpg

NOTE:
THE POSITION OF ALL POLE LINES, CONDUITS, WATERMANS, SEWERS AND OTHER UNDERGROUND AND OVERGROUND UTILITIES AND STRUCTURES IS NOT NECESSARILY SHOWN ON THE CONTRACT DRAWINGS, AND WHERE SHOWN, THE ACCURACY OF THE POSITION OF SUCH UTILITIES AND STRUCTURES IS NOT GUARANTEED. BEFORE STARTING WORK, DETERMINE THE EXACT LOCATION OF ALL SUCH UTILITIES AND STRUCTURES AND ASSUME ALL LIABILITY FOR DAMAGE TO THEM.

**PRELIMINARY
NOT FOR
CONSTRUCTION**

No.	REVISION	DATE	BY
6.	REVISED AS PER CITY OF OTTAWA COMMENTS	MAY 4/22	SAZ
5.	ISSUED FOR CITY OF OTTAWA REVIEW	DEC 23/21	MSP
4.	REVISED AS PER CITY OF OTTAWA COMMENTS	NOV 13/20	MSP
3.	REVISED AS PER CITY OF OTTAWA COMMENTS	MAY 8/20	MSP
2.	REVISED AS PER CITY OF OTTAWA COMMENTS	MAY 13/19	MSP
1.	ISSUED FOR DRAFT PLAN OF SUBDIVISION APPLICATION	JULY 23/18	MSP

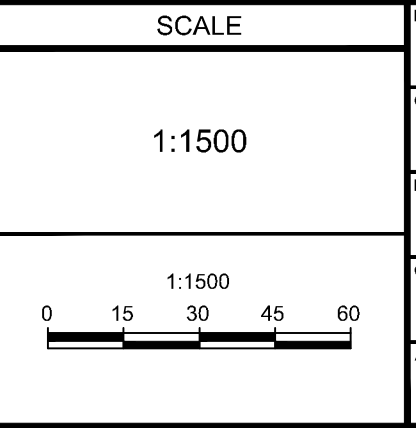

DESIGN	TJM
CHECKED	SAZ
DRAWN	MTM
CHECKED	SAZ
APPROVED	MSP

FOR REVIEW ONLY

REFER TO 116132-NL FOR ADDITIONAL NOTES

CITY OF OTTAWA COPPERWOOD ESTATE 1053, 1075 AND 1145 MARCH ROAD		PROJECT NO. 116132-00
DRAWING NAME SANITARY DRAINAGE AREA PLAN PHASE 1		REV # REV # 6
		DRAWING NO. 116132-SAN

#17801
D07-16-18-0023

APPENDIX D

Water Demands, Boundary Conditions, Schematic of the Hydraulic Model, Hydraulic Modeling Results and FUS Calculations

Devang Maratha

From: Candow, Julie <julie.candow@ottawa.ca>
Sent: Friday, May 6, 2022 9:08 AM
To: Francois Thauvette
Subject: RE: Ottawa Fire Station 45 - Request for WM boundary conditions

Thank you Francois, I have submitted your boundary condition request. Please note that Asset Management has advised us that boundary conditions can take up to 3 weeks due to backlog on their end.

Thanks,

Julie Candow, P.Eng

Project Manager
Planning, Real Estate and Economic Development Department - West Branch
City of Ottawa
110 Laurier Avenue West Ottawa, ON
613.580.2424 ext. 13850

Please take note that due to the current COVID situation, I am working remotely and phone communication may not be reliable at this time. The best way to reach me is by email.

From: Francois Thauvette <f.thauvette@novatech-eng.com>
Sent: May 05, 2022 3:35 PM
To: Candow, Julie <julie.candow@ottawa.ca>
Subject: Ottawa Fire Station 45 - Request for WM boundary conditions

CAUTION: This email originated from an External Sender. Please do not click links or open attachments unless you recognize the source.

ATTENTION : Ce courriel provient d'un expéditeur externe. Ne cliquez sur aucun lien et n'ouvrez pas de pièce jointe, excepté si vous connaissez l'expéditeur.

Hi Julie,

I am sending this e-mail to request WM boundary conditions for the proposed Fire Station #45 in Kanata North. The subject site is located at the intersection of March Road and Street 1. The building will be serviced off the new 300mm dia. WM in Street 1. The architect has confirmed that the building will be non-sprinklered and constructed of non-combustible materials. The anticipated water demands are as follows:

- Average Day Demand = 0.27 L/s
- Maximum Day Demand = 0.41 L/s
- Peak Hour Demand = 0.74 L/s
- Maximum Fire Flow Demand = 100 L/s (FUS)

See the attached PDFs of the **preliminary** architectural Site Plan and the preliminary calculation sheets for details. A multi-hydrant approach to firefighting is anticipated to be required. Based on a review of the subdivision plans, there will be three (3) municipal fire hydrants within 150m of the site, along Street 1, two of which will be within 75m of the site.

Regards,

François Thauvette, P. Eng., Senior Project Manager | Land Development & Public Sector Engineering

NOVATECH Engineers, Planners & Landscape Architects

Please note that I am working from home. Email or MS Teams are the best ways to contact me.

240 Michael Cowpland Drive, Suite 200, Ottawa, ON, K2M 1P6 | Tel: 613.254.9643 Ext: 219 | Cell: 613.276.0310 | Fax: 613.254.5867

The information contained in this email message is confidential and is for exclusive use of the addressee.

This e-mail originates from the City of Ottawa e-mail system. Any distribution, use or copying of this e-mail or the information it contains by other than the intended recipient(s) is unauthorized. Thank you.

Le présent courriel a été expédié par le système de courriels de la Ville d'Ottawa. Toute distribution, utilisation ou reproduction du courriel ou des renseignements qui s'y trouvent par une personne autre que son destinataire prévu est interdite. Je vous remercie de votre collaboration.

FIRE STATION 45

Domestic Water Demands (Staff and Use)

Avg. Daily Domestic Demand - <i>Staff</i> (280 L/person/day)	8	0.03
Avg. Daily Domestic Demand - <i>Trainee</i> (75 L/person/day)	22	0.02
Truck Washing (400 L/truck/wash)	3	0.01
Average Daily Demand		0.06 L/s
Max Day Demand = 1.5 x Avg. Daily Demand		0.09
Peak Hour Demand = 1.8 x Max Day Demand		0.16 L/s

***Excludes use of training hydrant on-site.**

FIRE STATION 45

Domesic Water Demands (Typical Institutional Use Basis)

Site Area	0.84 ha
Average Daily Water Demands - <i>Institutional</i>	28,000 L/ha/day
Average Daily Water Demand	0.27 L/s
Max Day Demand = 1.5 x Avg. Daily Demand	0.41
Peak Hour Demand = 1.8 x Max Day Demand	0.74 L/s

***Excludes use of training hydrant on-site.**

FUS - Fire Flow Calculations

As per 1999 Fire Underwriter's Survey Guidelines



Engineers, Planners & Landscape Architects

Novatech Project #: 122089
 Project Name: Ottawa Fire Station 45
 Date: 5/5/2022
 Input By: S. Matthews
 Reviewed By: F. Thauvette

Legend

Input by User
 No Information or Input Required

Building Description: 1-Storey Fire Station incl. Partial Mezzanine
 Non-combustible construction

Step	Input		Value Used	Total Fire Flow (L/min)	
Base Fire Flow					
1	Construction Material		Multiplier	0.8	
	Coefficient related to type of construction C	Wood frame			1.5
		Ordinary construction			1
		Non-combustible construction	Yes		0.8
		Modified Fire resistive construction (2 hrs)			0.6
Fire resistive construction (> 3 hrs)			0.6		
2	Floor Area			6,000	
	A	Building Footprint (m ²)	1344		
		Number of Floors/Storeys	1		
		Area of structure considered (m ²)			1,344
	F	Base fire flow without reductions			
$F = 220 C (A)^{0.5}$					
Reductions or Surcharges					
3	Occupancy hazard reduction or surcharge		Reduction/Surcharge	5,100	
	(1)	Non-combustible			-25%
		Limited combustible	Yes		-15%
		Combustible			0%
		Free burning			15%
Rapid burning			25%		
4	Sprinkler Reduction		Reduction	0	
	(2)	Adequately Designed System (NFPA 13)			-30%
		Standard Water Supply			-10%
		Fully Supervised System			-10%
Cumulative Total			0%		
5	Exposure Surcharge (cumulative %)		Surcharge	765	
	(3)	North Side	> 45.1m		0%
		East Side	> 45.1m		0%
		South Side	20.1 - 30 m		10%
		West Side	30.1 - 45 m		5%
Cumulative Total			15%		
Results					
6	(1) + (2) + (3)	Total Required Fire Flow, rounded to nearest 1000L/min		L/min	6,000
		(2,000 L/min < Fire Flow < 45,000 L/min)		or	100
				or	1,585
7	Storage Volume	Required Duration of Fire Flow (hours)		Hours	2
		Required Volume of Fire Flow (m ³)		m ³	720

Boundary Conditions 1075 March Road

Provided Information

Scenario	Demand	
	L/min	L/s
Average Daily Demand	16	0.27
Maximum Daily Demand	25	0.41
Peak Hour	44	0.74
→ Fire Flow Demand #1	6,000	100.00
Fire Flow Demand #2	10,000	166.67

Location

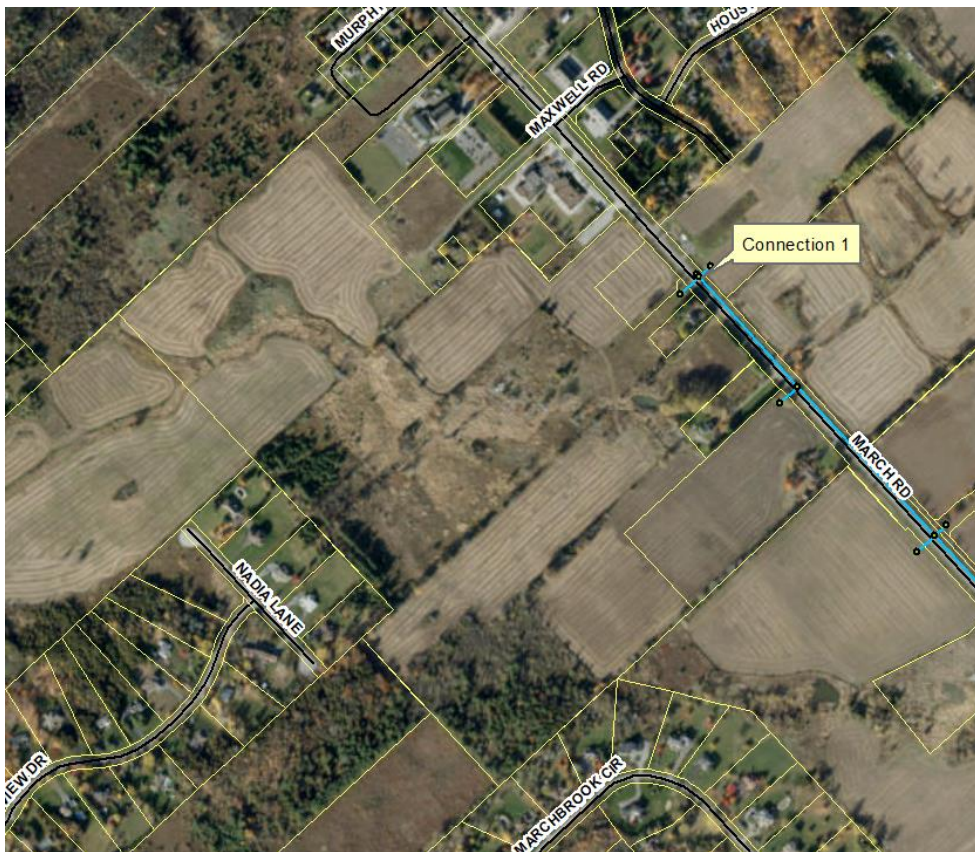

Results

Connection 1 – March Rd.

Demand Scenario	Head (m)	Pressure ¹ (psi)
Maximum HGL	131.0	69.5
Peak Hour	126.2	62.7
→ Max Day plus Fire 1	124.6	60.4
Max Day plus Fire 2	120.2	54.1

Ground Elevation = 82.13 m

Disclaimer

The boundary condition information is based on current operation of the city water distribution system. The computer model simulation is based on the best information available at the time. The operation of the water distribution system can change on a regular basis, resulting in a variation in boundary conditions. The physical properties of watermains deteriorate over time, as such must be assumed in the absence of actual field test data. The variation in physical watermain properties can therefore alter the results of the computer model simulation. Fire Flow analysis is a reflection of available flow in the watermain; there may be additional restrictions that occur between the watermain and the hydrant that the model cannot take into account.

Fire Station #45

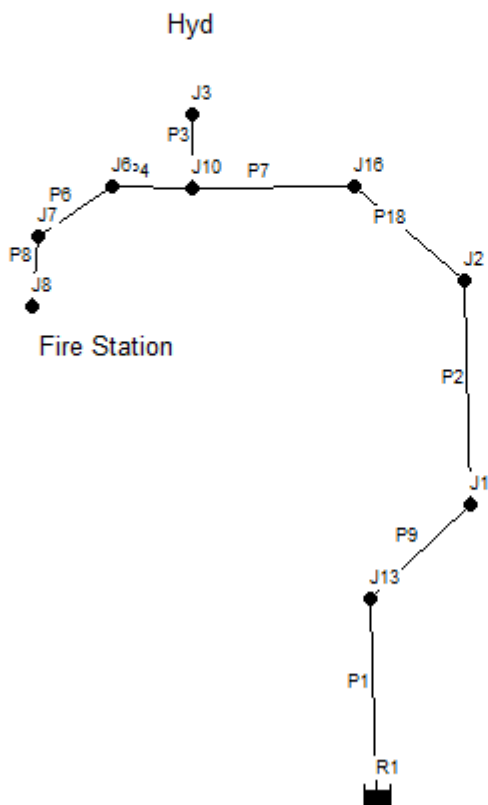

Street 1

Fire Station 45 - Watermain Analysis

Peak Hour Demand
Network Table - Nodes

Node ID	Elevation m	Demand L/s	Head m	Pressure m	Pressure kPa	Pressure psi
Junc J1	80.7	0	126.2	45.5	446.36	64.74
Junc J2	80.8	0	126.2	45.4	445.37	64.60
Junc J13	80.7	0	126.2	45.5	446.36	64.74
Junc J16	81	0	126.2	45.2	443.41	64.31
Junc J10	81	0	126.2	45.2	443.41	64.31
Junc J3	84	0	126.2	42.2	413.98	60.04
Junc J6	81	0	126.2	45.2	443.41	64.31
Junc J7	81	0	126.2	45.2	443.41	64.31
Junc J8	83.5	0.16	126.2	42.7	418.89	60.75
Resvr R1	126.2	-0.16	126.2	0	0.00	0.00

Peak Hour Demand
Network Table - Links

Link ID	Length m	Diameter mm	Roughness	Flow L/s	Velocity m/s	Unit Headloss m/km
Pipe P2	29.5	200	110	0.16	0.01	0
Pipe P1	19.1	200	110	0.16	0.01	0
Pipe P9	15.1	200	110	0.16	0.01	0
Pipe P18	5.9	200	110	0.16	0.01	0
Pipe P7	18.6	200	110	-0.16	0.01	0
Pipe P3	3.1	150	100	0	0	0
Pipe P4	1.2	200	110	0.16	0.01	0
Pipe P6	2.2	150	100	0.16	0.01	0
Pipe P8	3.9	150	100	0.16	0.01	0

Fire Station 45 - Watermain Analysis

Max HGL check
Network Table - Nodes

Node ID	Elevation m	Demand L/s	Head m	Pressure m	Pressure kPa	Pressure psi
Junc J1	80.7	0	131	50.3	493.44	71.57
Junc J2	80.8	0	131	50.2	492.46	71.43
Junc J13	80.7	0	131	50.3	493.44	71.57
Junc J16	81	0	131	50	490.50	71.14
Junc J10	81	0	131	50	490.50	71.14
Junc J3	84	0	131	47	461.07	66.87
Junc J6	81	0	131	50	490.50	71.14
Junc J7	81	0	131	50	490.50	71.14
Junc J8	83.5	0.1	131	47.5	465.98	67.58
Resvr R1	131	-0.1	131	0	0.00	0.00

Max HGL check
Network Table - Links

Link ID	Length m	Diameter mm	Roughness	Flow L/s	Velocity m/s	Unit Headloss m/km
Pipe P2	29.5	200	110	0.1	0	0
Pipe P1	19.1	200	110	0.1	0	0
Pipe P9	15.1	200	110	0.1	0	0
Pipe P18	5.9	200	110	0.1	0	0
Pipe P7	18.6	200	110	-0.1	0	0
Pipe P3	3.1	150	100	0	0	0
Pipe P4	1.2	200	110	0.1	0	0
Pipe P6	2.2	150	100	0.1	0.01	0
Pipe P8	3.9	150	100	0.1	0.01	0

Fire Station 45 - Watermain Analysis

Max Day + Fire Flow Demand

Network Table - Nodes

Node ID	Elevation m	Demand L/s	Head m	Pressure m	Pressure kPa	Pressure psi
Junc J1	80.7	0	122.63	41.93	411.33	59.66
Junc J2	80.8	0	120.94	40.14	393.77	57.11
Junc J13	80.7	0	123.5	42.8	419.87	60.90
Junc J16	81	0	120.6	39.6	388.48	56.34
Junc J10	81	0	119.53	38.53	377.98	54.82
Junc J3	84	95	118.67	34.67	340.11	49.33
Junc J6	81	0	119.53	38.53	377.98	54.82
Junc J7	81	0	119.53	38.53	377.98	54.82
Junc J8	83.5	0.1	119.53	36.03	353.45	51.26
Resvr R1	124.6	-95.1	124.6	0	0.00	0.00

Max Day + Fire Flow Demand

Network Table - Links

Link ID	Length m	Diameter mm	Roughness	Flow L/s	Velocity m/s	Unit Headloss m/km
Pipe P2	29.5	200	110	95.1	3.03	57.5
Pipe P1	19.1	200	110	95.1	3.03	57.5
Pipe P9	15.1	200	110	95.1	3.03	57.5
Pipe P18	5.9	200	110	95.1	3.03	57.5
Pipe P7	18.6	200	110	-95.1	3.03	57.5
Pipe P3	3.1	150	100	95	5.38	277.99
Pipe P4	1.2	200	110	0.1	0	0
Pipe P6	2.2	150	100	0.1	0.01	0
Pipe P8	3.9	150	100	0.1	0.01	0

APPENDIX E

**IDF Curves and SWM Calculations, Storm Sewer Design Sheets, Excerpts from the
Copperwood Estates – Site Servicing and SWM Report²**

APPENDIX 5-A

OTTAWA INTENSITY DURATION FREQUENCY (IDF) CURVE

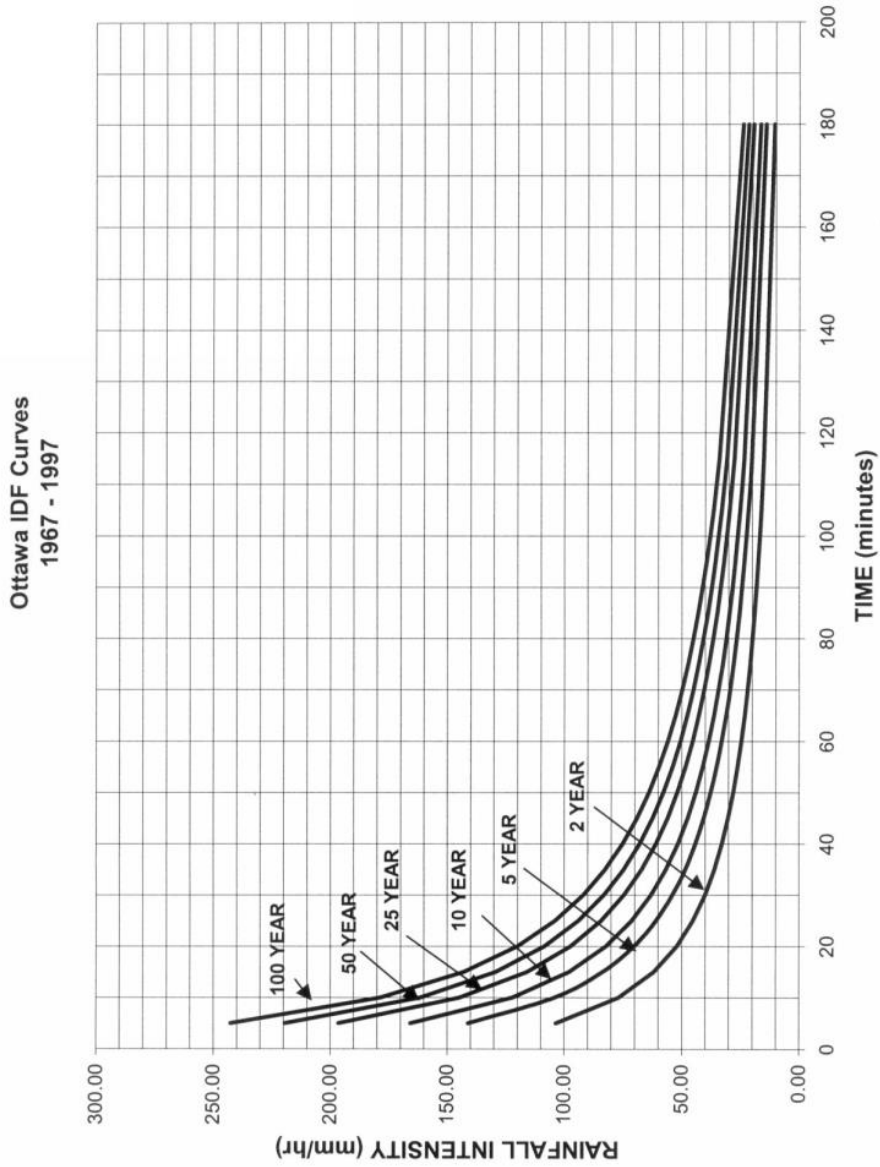

Proposed Fire Station 45 1075-A March Road

Pre - Development : Site Flows							
Description	Area (ha)	$A_{impervious} (ha)$ C=0.9	$A_{gravel} (ha)$ C=0.6	$A_{pervious} (ha)$ C=0.2	Weighted C_{W5}	Weighted C_{W100}	Allowable Release Rate
							Per Copperwood Estates Detailed Site Servicing & SWM Report
Total Site Area	0.837	0.000	0.000	0.837	0.20	0.25	221.9

Post - Development : Site Flows														
Area	Description	Area (ha)	$A_{imp} (ha)$ C=0.9	$A_{perv} (ha)$ C=0.2	C_{W5}	C_{W100}	Uncontrolled Flow (L/s)*			Controlled Flow (L/s)		Storage Required (m ³)		Provided (m ³)
							2 year	5 year	100 year	5 year	100 year	5 year	100 year	
A-0	Direct Runoff to Buckbean Street	0.084	0.048	0.036	0.60	0.68	-	14.6	28.2	-	-	-	-	-
A-1	Uncontrolled Area (West Parking)	0.135	0.071	0.064	0.57	0.64	-	22.2	43.2	-	-	-	-	-
A-2	Uncontrolled Area (Rear Parking)	0.073	0.042	0.031	0.60	0.68	-	12.7	24.6	-	-	-	-	-
A-3	Uncontrolled Area (Rear Parking)	0.091	0.029	0.062	0.42	0.49	-	11.2	22.1	-	-	-	-	-
A-4	Uncontrolled Area (Rear)	0.046	0.044	0.002	0.87	0.97	-	11.6	22.2	-	-	-	-	-
A-5	Uncontrolled Roof and Landscape	0.240	0.073	0.167	0.41	0.48	-	28.7	57.0	-	-	-	-	-
A-6	Uncontrolled Landscape (Front)	0.072	0.012	0.060	0.32	0.37	-	6.6	13.4	-	-	-	-	-
A-7	Direct Runoff to March Road	0.046	0.000	0.046	0.20	0.25	-	2.7	5.7	-	-	-	-	-
R-1	Controlled Flow Roof Drains	0.050	0.050	0.000	0.90	1.00	-	-	-	2.4	3.3	8.0	17.9	29.3
Area Check: 0.837							$T_c = 10\text{mins}$		Totals:	2.4	3.3	8.0	17.9	29.3

Proposed Fire Station 45					
Novatech Project No. 122089					
REQUIRED STORAGE - 1:2 YEAR EVENT					
AREAS R-1			Controlled Roof Drains 1+2		
OTTAWA IDF CURVE					
Area =	0.049	ha	Qallow =	1.76	L/s
C =	0.90		Vol(max) =	5.7	m ³
Time (min)	Intensity (mm/hr)	Q (L/s)	Qnet (L/s)	Vol (m ³)	
5	103.57	12.70	10.94	3.28	
10	76.81	9.42	7.66	4.59	
15	61.77	7.57	5.81	5.23	
20	52.03	6.38	4.62	5.54	
25	45.17	5.54	3.78	5.67	
30	40.04	4.91	3.15	5.67	
35	36.06	4.42	2.66	5.59	
40	32.86	4.03	2.27	5.45	
45	30.24	3.71	1.95	5.26	
50	28.04	3.44	1.68	5.03	
55	26.17	3.21	1.45	4.78	
60	24.56	3.01	1.25	4.50	
65	23.15	2.84	1.08	4.21	
70	21.91	2.69	0.93	3.89	
75	20.81	2.55	0.79	3.56	
90	18.14	2.22	0.46	2.51	
105	16.13	1.98	0.22	1.37	
120	14.56	1.79	0.03	0.18	

Proposed Fire Station 45					
Novatech Project No. 122089					
REQUIRED STORAGE - 1:5 YEAR EVENT					
AREAS R-1			Controlled Roof Drains 1+2		
OTTAWA IDF CURVE					
Area =	0.049	ha	Qallow =	2.14	L/s
C =	0.90		Vol(max) =	8.0	m ³
Time (min)	Intensity (mm/hr)	Q (L/s)	Qnet (L/s)	Vol (m ³)	
5	141.18	17.31	15.17	4.55	
10	104.19	12.77	10.63	6.38	
15	83.56	10.24	8.10	7.29	
20	70.25	8.61	6.47	7.77	
25	60.90	7.47	5.33	7.99	
30	53.93	6.61	4.47	8.05	
35	48.52	5.95	3.81	8.00	
40	44.18	5.42	3.28	7.86	
45	40.63	4.98	2.84	7.67	
50	37.65	4.62	2.48	7.43	
55	35.12	4.31	2.17	7.15	
60	32.94	4.04	1.90	6.84	
65	31.04	3.81	1.67	6.50	
70	29.37	3.60	1.46	6.14	
75	27.89	3.42	1.28	5.76	
90	24.29	2.98	0.84	4.52	
105	21.58	2.65	0.51	3.19	
120	19.47	2.39	0.25	1.78	

Watts Accutrol Flow Control Roof Drains: RD-100-A-ADJ weir set to Fully-Exposed					
Design Event	Flow/Drain (L/s)	Total Flow (L/s)	Ponding (cm)	Required Storage (m ²)	Provided
1:2 Year	0.88	1.76	7	5.7	
1:5 Year	1.07	2.14	9	8.0	29.3
1:100 Year	1.39	2.78	12	17.9	

Roof Drain Storage Table for Area RD 1+2		
Elevation	Area RD 1+2	Total Volume
m	m ²	m ³
0.00	0	0
0.05	104.18	2.6
0.10	252.26	11.5
0.15	457.5	29.3

Stage Storage Curve: Areas R-1 Controlled Roof Drains 1+2

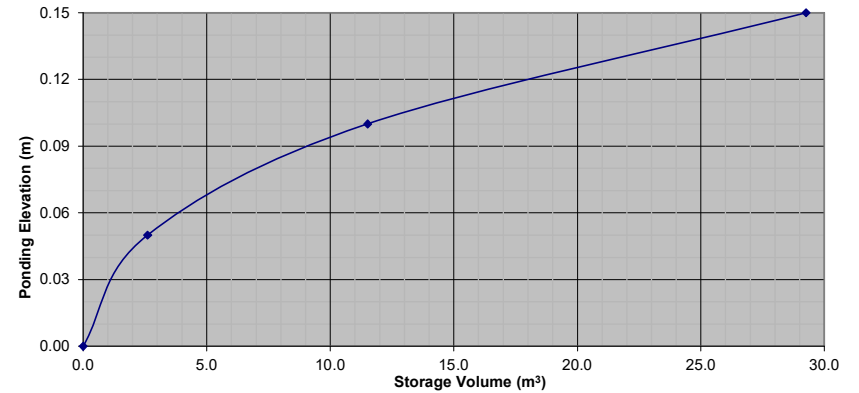

Proposed Fire Station 45					
Novatech Project No. 122089					
REQUIRED STORAGE - 1:100 YEAR EVENT					
AREAS R-1			Controlled Roof Drains 1+2		
OTTAWA IDF CURVE					
Area =	0.049	ha	Qallow =	2.78	L/s
C =	1.00		Vol(max) =	17.9	m ³
Time (min)	Intensity (mm/hr)	Q (L/s)	Qnet (L/s)	Vol (m ³)	
5	242.70	33.06	30.28	9.08	
10	178.56	24.32	21.54	12.93	
15	142.89	19.47	16.69	15.02	
20	119.95	16.34	13.56	16.27	
25	103.85	14.15	11.37	17.05	
30	91.87	12.51	9.73	17.52	
35	82.58	11.25	8.47	17.78	
40	75.15	10.24	7.46	17.90	
45	69.05	9.41	6.63	17.89	
50	63.95	8.71	5.93	17.80	
55	59.62	8.12	5.34	17.63	
60	55.89	7.61	4.83	17.40	
65	52.65	7.17	4.39	17.13	
70	49.79	6.78	4.00	16.81	
75	47.26	6.44	3.66	16.46	
90	41.11	5.60	2.82	15.23	
105	36.50	4.97	2.19	13.81	
120	32.89	4.48	1.70	12.25	

Proposed Fire Station 45					
Novatech Project No. 122089					
REQUIRED STORAGE - 1:100 YEAR + 20%					
AREAS R-1			Controlled Roof Drains 1+2		
OTTAWA IDF CURVE					
Area =	0.049	ha	Qallow =	3.14	L/s
C =	1.00		Vol(max) =	22.0	m ³
Time (min)	Intensity (mm/hr)	Q (L/s)	Qnet (L/s)	Vol (m ³)	
5	291.24	39.67	36.53	10.96	
10	214.27	29.19	26.05	15.63	
15	171.47	23.36	20.22	18.20	
20	143.94	19.61	16.47	19.76	
25	124.62	16.98	13.84	20.75	
30	110.24	15.02	11.88	21.38	
35	99.09	13.50	10.36	21.75	
40	90.17	12.28	9.14	21.94	
45	82.86	11.29	8.15	22.00	
50	76.74	10.45	7.31	21.94	
55	71.55	9.75	6.61	21.80	
60	67.07	9.14	6.00	21.59	
65	63.18	8.61	5.47	21.32	
70	59.75	8.14	5.00	21.00	
75	56.71	7.72	4.58	20.63	
90	49.33	6.72	3.58	19.33	
105	43.80	5.97	2.83	17.80	
120	39.47	5.38	2.24	16.11	

FIRE STATION 45 - 5 Year Storm Sewer Design Sheet

LOCATION			AREA (Ha)		FLOW					PROPOSED SEWER							Q/Qfull	
AREA ID	FROM	TO	AREA	R	INDIV 2.78 AR	ACCUM 2.78 AR	TIME OF CONC.	RAINFALL INTENSITY I	PEAK FLOW Q (l/s)	PIPE SIZE (mm)	PIPE SLOPE (%)	LENGTH (m)	CAPACITY (l/s)	FULL FLOW VELOCITY (m/s)	TIME OF FLOW (min.)	EXCESS CAPACITY (l/s)		
A-1	CB1	CBMH1	0.135	0.57	0.21	0.21	10.00	104.19	22.29	250.0	0.45	28.3	39.93	0.81	0.58	17.64	0.56	
A-2	CB2	PIPE	0.073	0.60	0.12	0.12	10.00	104.19	12.69	200.0	1.00	0.8	32.83	1.04	0.01	20.14	0.39	
A-3	CBMH1	CBMH2	0.091	0.42	0.11	0.44	10.58	101.22	44.73	300.0	0.35	43.7	57.27	0.81	0.90	12.53	0.78	
A-4	CBMH 2	STMMH 1	0.046	0.87	0.11	0.55	11.48	96.97	53.65	375.0	0.35	20.1	103.83	0.94	0.36	50.19	0.52	
	STMMH 1	STMMH2	0.000	0.00	0.00	0.55	11.84	95.40	52.77	375.0	0.35	35.5	103.83	0.94	0.63	51.06	0.51	
A-5	CB3	STMMH2	0.240	0.41	0.27	0.27	10.00	104.19	28.50	250.0	1.00	9.5	59.53	1.21	0.13	31.03	0.48	
	STMMH2	STMMH3	0.000	0.00	0.00	0.83	12.47	92.75	76.68	375.0	0.35	16.1	103.83	0.94	0.29	27.15	0.74	
R-1	BLDG	CBMH3	0.050	0.90	0.13	0.13	10.00	104.19	13.03	200.0	1.00	9.0	32.83	1.04	0.14	19.80	0.40	
	BLDG	CBMH3	CONTROL FLOW ROOF DRAINS							2.40								0.07
A-6	CBMH 3	STMMH3	0.072	0.32	0.06	0.19	10.14	103.44	8.98	200.0	0.60	35.4	25.43	0.81	0.73	16.45	0.35	
	STMMH3	EX	0.000	0.00	0.00	0.89	12.75	91.60	83.95	375.0	0.50	17.8	124.10	1.12	0.26	40.15	0.68	

Definitions

Q = 2.78 AIR
 Q = Peak Flow, in Litres per second (L/s)
 A = Area in hectares (ha)
 I = 2 Year Rainfall Intensity (mm/h)
 R = Runoff Coefficient

Notes:

1) Ottawa Rainfall-Intensity Curve
 2) Min Velocity = 0.8 m/sec.
 3) 5 Year intensity = $998.071 / (\text{time} + 6.053)^{0.814}$
 10 Year intensity = $1174.184 / (\text{time} + 6.014)^{0.816}$
 100 Year intensity = $1735.688 / (\text{time} + 6.014)^{0.820}$

FIRE STATION 45 - 100 Year Storm Sewer Design Sheet

LOCATION			AREA (Ha)		FLOW					PROPOSED SEWER							Q/Qfull	
AREA ID	FROM	TO	AREA	R	INDIV 2.78 AR	ACCUM 2.78 AR	TIME OF CONC.	RAINFALL INTENSITY I	PEAK FLOW Q (l/s)	PIPE SIZE (mm)	PIPE SLOPE (%)	LENGTH (m)	CAPACITY (l/s)	FULL FLOW VELOCITY (m/s)	TIME OF FLOW (min.)	EXCESS CAPACITY (l/s)		
A-1	CB1	CBMH1	0.135	0.64	0.24	0.24	10.00	178.56	42.89	250.0	0.45	28.3	39.93	0.81	0.58	-2.96	1.07	
A-2	CB2	PIPE	0.073	0.68	0.14	0.14	10.00	178.56	24.64	200.0	1.00	0.8	32.83	1.04	0.01	8.19	0.75	
A-3	CBMH1	CBMH2	0.091	0.49	0.12	0.50	10.58	173.42	87.08	300.0	0.35	43.7	57.27	0.81	0.90	-29.82	1.52	
A-4	CBMH 2	STMMH 1	0.046	0.97	0.12	0.63	11.48	166.07	103.99	375.0	0.35	20.1	103.83	0.94	0.36	-0.16	1.00	
	STMMH 1	STMMH2	0.000	0.00	0.00	0.63	11.84	163.35	102.29	375.0	0.35	35.5	103.83	0.94	0.63	1.54	0.99	
A-5	CB3	STMMH2	0.240	0.48	0.32	0.32	10.00	178.56	57.18	250.0	1.00	9.5	59.53	1.21	0.13	2.34	0.96	
	STMMH2	STMMH3	0.000	0.00	0.00	0.95	12.47	158.77	150.26	375.0	0.35	16.1	103.83	0.94	0.29	-46.43	1.45	
R-1	BLDG	CBMH3	0.050	1.00	0.14	0.14	10.00	178.56	24.82	200.0	1.00	9.0	32.83	1.04	0.14	8.01	0.76	
	BLDG	CBMH3	CONTROL FLOW ROOF DRAINS							3.30								0.10
A-6	CBMH 3	STMMH3	0.072	0.37	0.07	0.21	10.14	177.26	16.34	200.0	0.60	35.4	25.43	0.81	0.73	9.09	0.64	
	STMMH3	EX	0.000	0.00	0.00	1.02	12.75	156.78	163.22	375.0	0.50	17.8	124.10	1.12	0.26	-39.11	1.32	

Definitions

Q = 2.78 AIR
 Q = Peak Flow, in Litres per second (L/s)
 A = Area in hectares (ha)
 I = 2 Year Rainfall Intensity (mm/h)
 R = Runoff Coefficient

Notes:

1) Ottawa Rainfall-Intensity Curve
 2) Min Velocity = 0.8 m/sec.
 3) 5 Year intensity = $998.071 / (\text{time} + 6.053)^{0.814}$
 10 Year intensity = $1174.184 / (\text{time} + 6.014)^{0.816}$
 100 Year intensity = $1735.688 / (\text{time} + 6.014)^{0.820}$

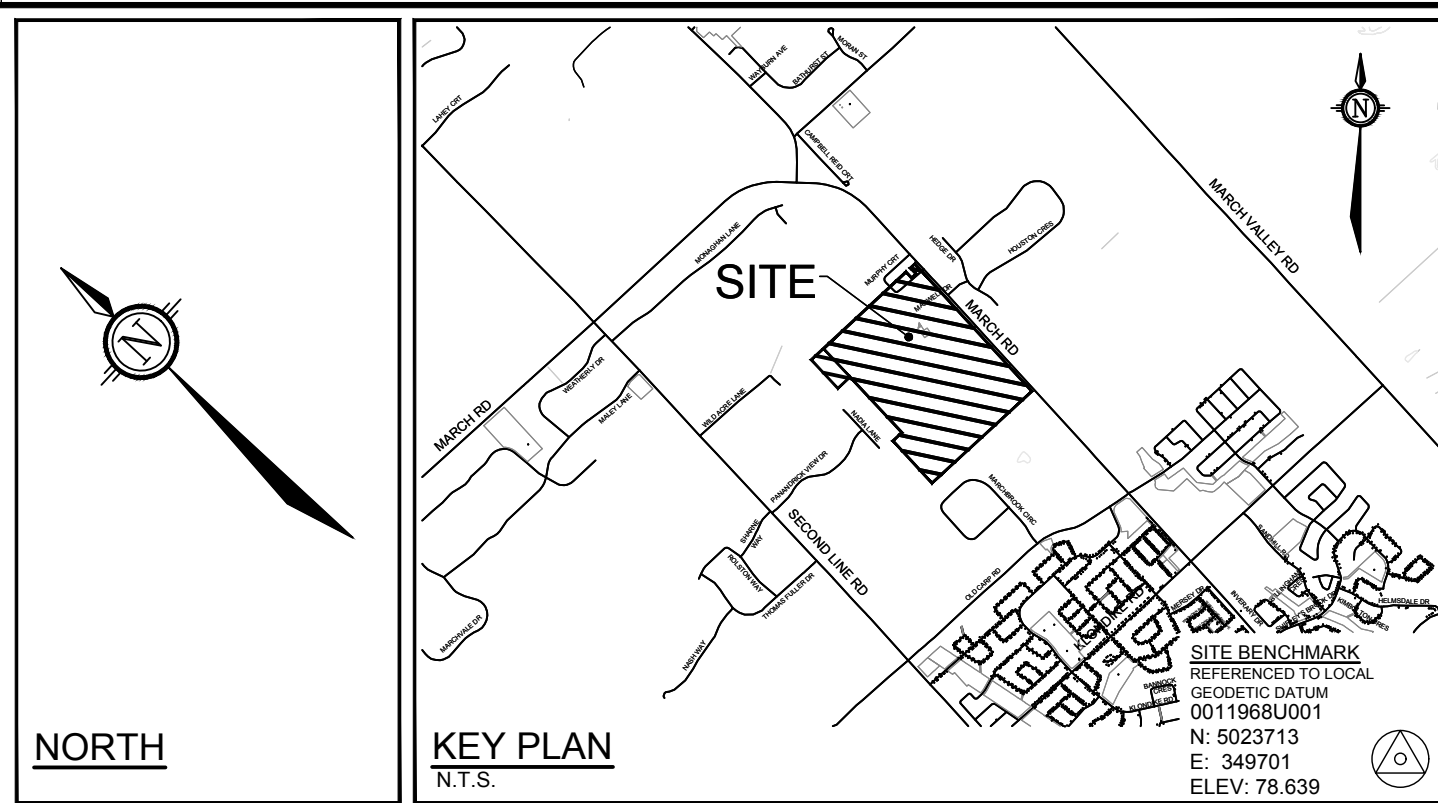
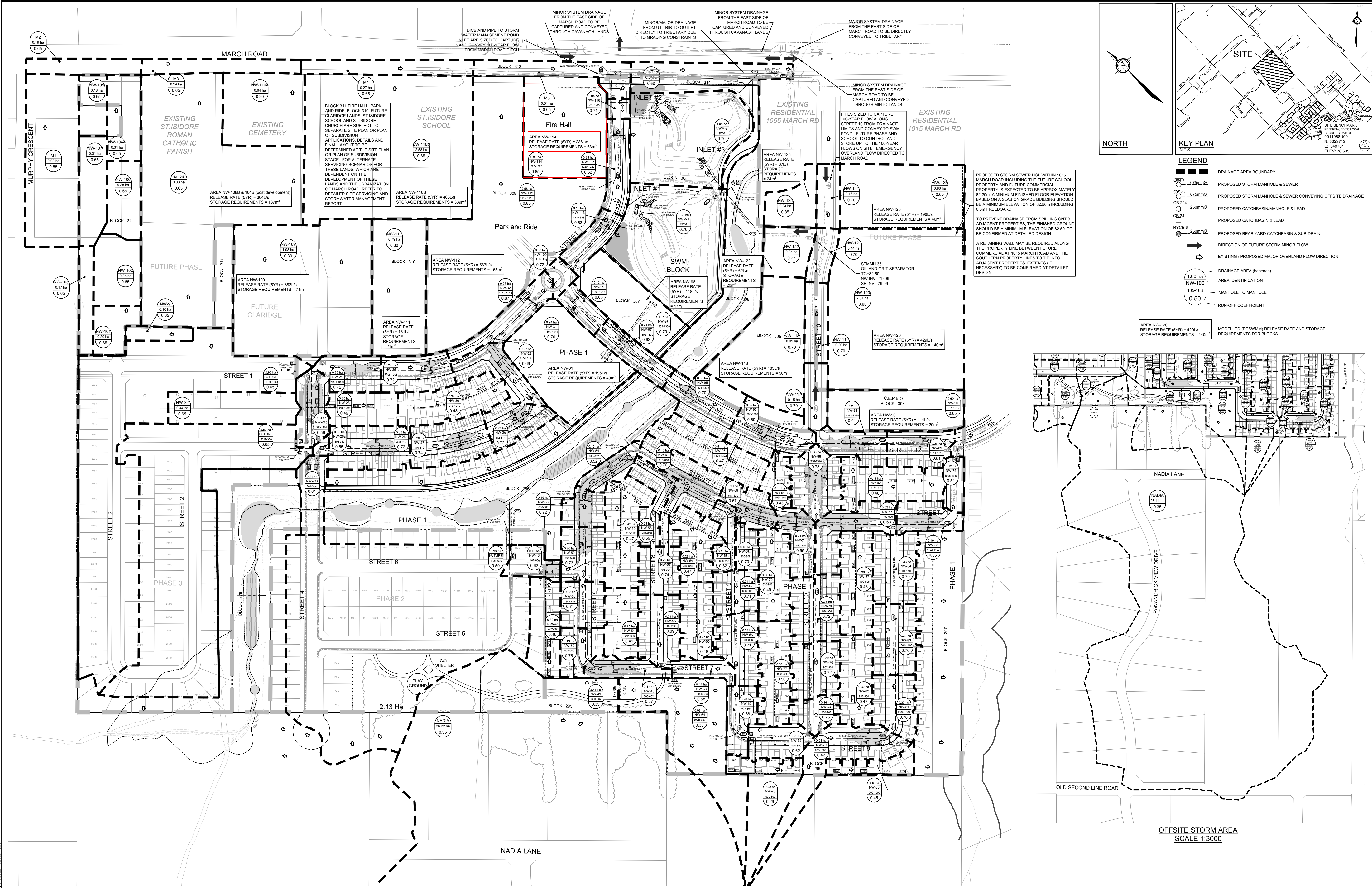

- LEGEND**
- DRAINAGE AREA BOUNDARY
 - PROPOSED STORM MANHOLE & SEWER
 - PROPOSED STORM MANHOLE & SEWER CONVEYING OFFSITE DRAINAGE
 - PROPOSED CATCHBASIN/MANHOLE & LEAD
 - PROPOSED CATCHBASIN & LEAD
 - PROPOSED REAR YARD CATCHBASIN & SUB-DRAIN
 - DIRECTION OF FUTURE STORM MINOR FLOW
 - ◇ EXISTING / PROPOSED MAJOR OVERLAND FLOW DIRECTION
 - 1.00 ha DRAINAGE AREA (hectares)
 - NW-100 AREA IDENTIFICATION
 - 105-103 MANHOLE TO MANHOLE
 - 0.50 RUN-OFF COEFFICIENT
 - AREA NW-120 RELEASE RATE (SYR) = 428L/s STORAGE REQUIREMENTS = 140m³ MODELLED (PCSWMM) RELEASE RATE AND STORAGE REQUIREMENTS FOR BLOCKS

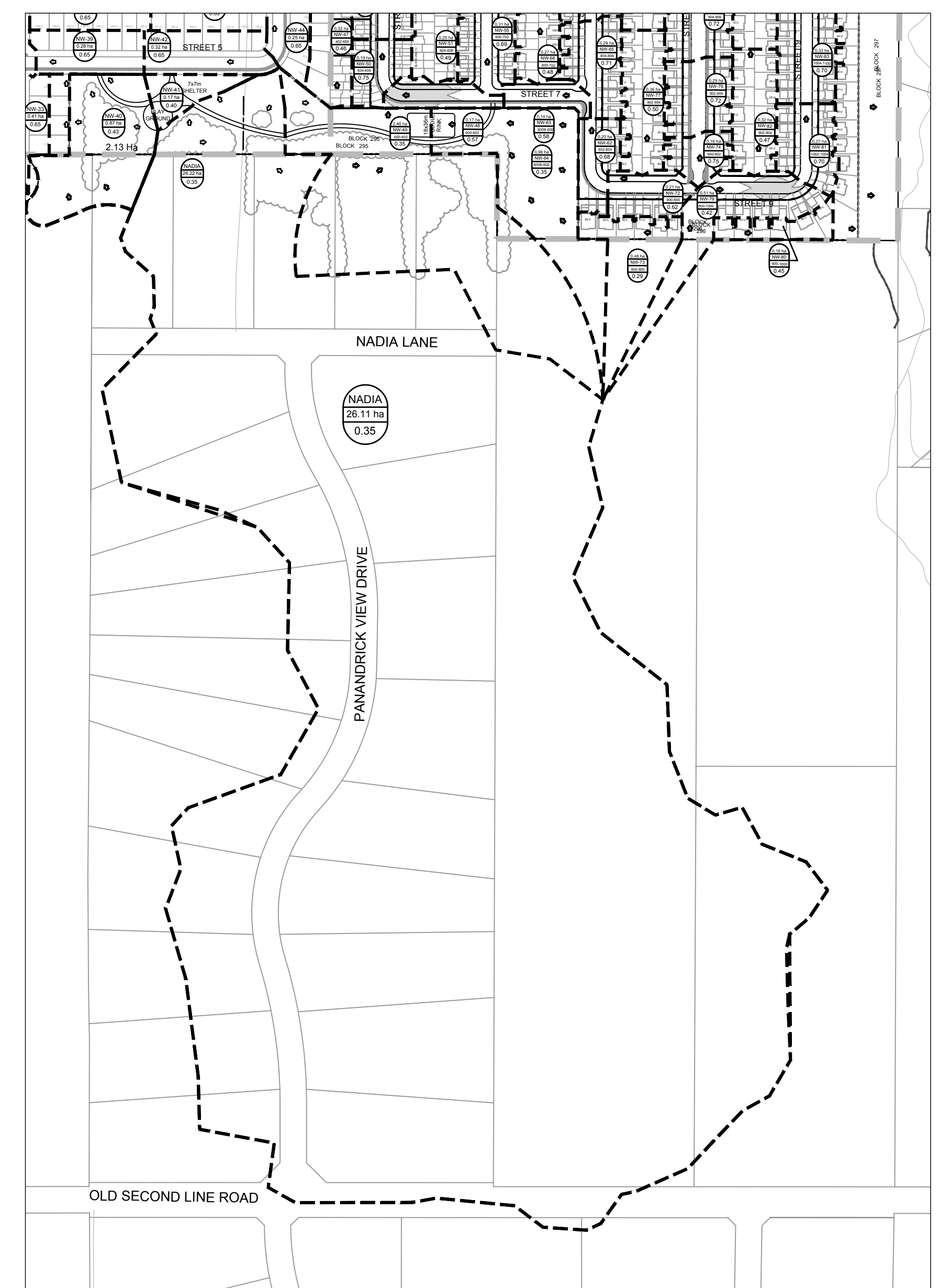

OFFSITE STORM AREA SCALE 1:3000

REFER TO OFFSITE STORM AREA VIEW

REFER TO 116132-NL FOR ADDITIONAL NOTES

NOTE:
THE POSITION OF ALL POLE LINES, CONDUITS, WATERMANS, SEWERS AND OTHER UNDERGROUND AND OVERGROUND UTILITIES AND STRUCTURES IS NOT NECESSARILY SHOWN ON THE CONTRACT DRAWINGS, AND WHERE SHOWN, THE ACCURACY OF THE POSITION OF SUCH UTILITIES AND STRUCTURES IS NOT GUARANTEED. BEFORE STARTING WORK, DETERMINE THE EXACT LOCATION OF ALL SUCH UTILITIES AND STRUCTURES AND ASSUME ALL LIABILITY FOR DAMAGE TO THEM.

**PRELIMINARY
NOT FOR
CONSTRUCTION**

NO.	REVISION	DATE	BY
7	REVISED AS PER CITY OF OTTAWA COMMENTS	MAY 4/22	SAZ
6	ISSUED FOR CITY OF OTTAWA REVIEW	DEC 23/21	SAZ
5	ISSUED TO MISSISSIPPI VALLEY CONSERVATION AUTHORITY FOR REVIEW	DEC 22/21	SAZ
4	REVISED AS PER CITY OF OTTAWA COMMENTS	NOV 13/20	MSP
3	REVISED AS PER CITY OF OTTAWA COMMENTS	MAY 8/20	MSP
2	REVISED AS PER CITY OF OTTAWA COMMENTS	MAY 13/19	MSP
1	ISSUED FOR DRAFT PLAN OF SUBDIVISION APPLICATION	JULY 23/18	MSP

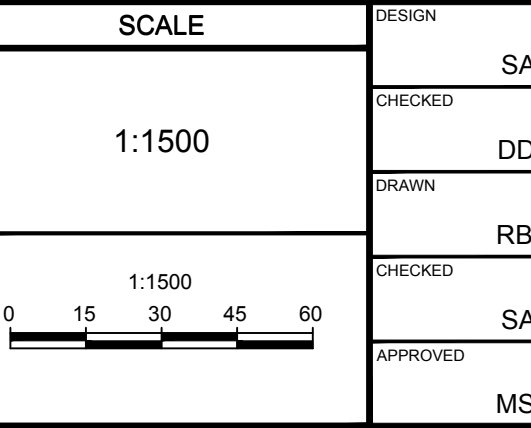

DESIGN	SCALE	FOR REVIEW ONLY
SAZ	1:1500	FOR REVIEW ONLY
DBB		
RBG		
SAZ		
MSP		

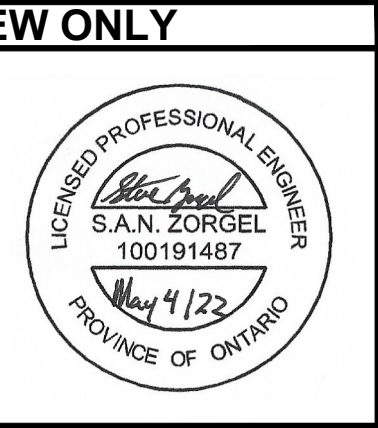

NOVATECH
Engineers, Planners & Landscape Architects
Suite 200, 240 Michael Copland Drive
Ottawa, Ontario, Canada K2M 1P6
Telephone: (613) 254-9643
Facsimile: (613) 254-5867
Website: www.novatech-eng.com

CITY OF OTTAWA COPPERWOOD ESTATE 1053, 1075 AND 1145 MARCH ROAD		PROJECT NO: 116132-00
DRAWING NAME STORM DRAINAGE AREA PLAN PHASE 1		REV #7
DRAWING NO: 116132-STM		

#17801 D07-16-18-0023

APPENDIX F
Control Flow Roof Drain
Information



Adjustable Accutrol Weir
 Tag: RD-100-A-ADJ

**Adjustable Flow Control
 for Roof Drains**

ADJUSTABLE ACCUTROL (for Large Sump Roof Drains only)

For more flexibility in controlling flow with heads deeper than 2", Watts Drainage offers the Adjustable Accutrol. The Adjustable Accutrol Weir is designed with a single parabolic opening that can be covered to restrict flow above 2" of head to less than 5 gpm per inch, up to 6" of head. To adjust the flow rate for depths over 2" of head, set the slot in the adjustable upper cone according to the flow rate required. Refer to Table 1 below.
 Note: Flow rates are directly proportional to the amount of weir opening that is exposed.

EXAMPLE:

For example, if the adjustable upper cone is set to cover 1/2 of the weir opening, flow rates above 2" of head will be restricted to 2-1/2 gpm per inch of head.

Therefore, at 3" of head, the flow rate through the Accutrol Weir that has 1/2 the slot exposed will be:
 [5 gpm (per inch of head) x 2 inches of head] + 2-1/2 gpm (for the third inch of head) = 12-1/2 gpm.

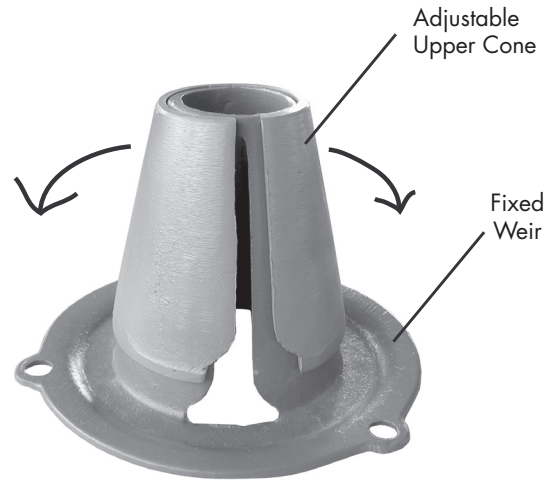
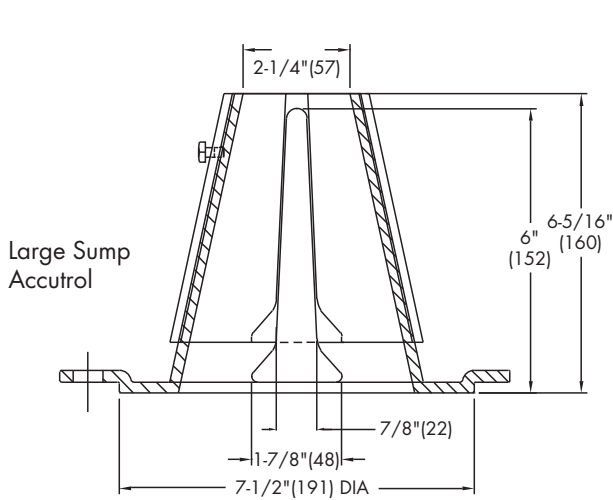

1/2 Weir Opening Exposed Shown Above

TABLE 1. Adjustable Accutrol Flow Rate Settings

Weir Opening Exposed	1"	2"	3"	4"	5"	6"
	Flow Rate (gallons per minute)					
Fully Exposed	5	10	15	20	25	30
3/4	5	10	13.75	17.5	21.25	25
1/2	5	10	12.5	15	17.5	20
1/4	5	10	11.25	12.5	13.75	15
Closed	5	5	5	5	5	5

Job Name _____
 Job Location _____
 Engineer _____

Contractor _____
 Contractor's P.O. No. _____
 Representative _____

Watts product specifications in U.S. customary units and metric are approximate and are provided for reference only. For precise measurements, please contact Watts Technical Service. Watts reserves the right to change or modify product design, construction, specifications, or materials without prior notice and without incurring any obligation to make such changes and modifications on Watts products previously or subsequently sold.

USA: Tel: (800) 338-2581 • Fax: (828) 248-3929 • Watts.com
Canada: Tel: (905) 332-4090 • Fax: (905) 332-7068 • Watts.ca
Latin America: Tel: (52) 81-1001-8600 • Fax: (52) 81-8000-7091 • Watts.com



A Watts Water Technologies Company

LEGEND

- PROPERTY LINE
- PROPOSED SANITARY MH & SEWER
- PROPOSED CATCHBASIN MH & SEWER c/w 3.0m RADIAL SUBDRAIN (PER GEOTECH)
- PROPOSED STORM MH & SEWER
- PROPOSED CATCHBASIN & LEAD c/w 3.0m RADIAL SUBDRAIN (PER GEOTECH)
- PROPOSED HYDRANT c/w VALVE & VALVE BOX
- PROPOSED INLET CONTROL DEVICE
- CONTROLLED FLOW ROOF DRAIN
- PROPOSED WATER METER AND REMOTE METER
- DC PROPOSED DEPRESSION CURB
- 150mmØ PROPOSED WATER SERVICE AND DIAMETER
- VB PROPOSED VALVE & VALVE BOX
- BEND PROPOSED BEND AND THRUSTBLOCK
- 11.25°, 22.5°, 45° PROPOSED CAP
- PROPOSED BUILDING ENTRANCE
- THERMAL INSULATION FOR SHALLOW SEWERS
- PROPOSED HYDRO TRANSFORMER
- DS DOWNSPOUT
- FFE FINISHED FLOOR ELEVATION
- T/FND TOP OF FOUNDATION WALL ELEVATION
- USF UNDERSIDE OF FOOTING ELEVATION
- EXISTING CONCRETE CURB
- EXISTING SANITARY MANHOLE & SEWER
- EXISTING CATCHBASIN MANHOLE
- EXISTING STORM MANHOLE & SEWER
- EXISTING CATCHBASIN c/w CATCHBASIN LEAD
- EXISTING HYDRANT & VALVE
- EXISTING WATERMAIN
- EXISTING HYDRANT c/w VALVE & LEAD
- EXISTING TREES / VEGETATION
- EXISTING UTILITY POLE

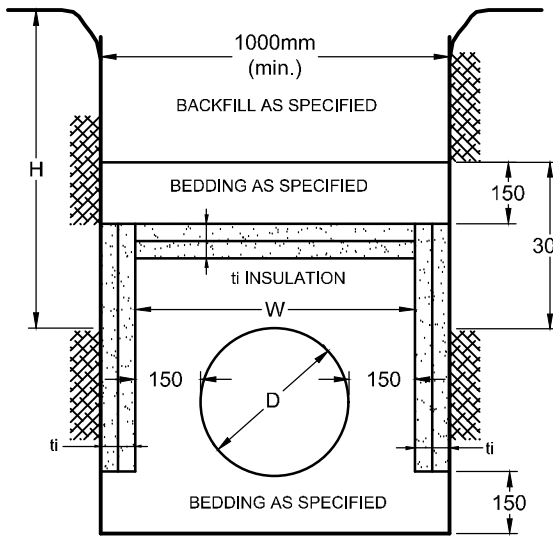

1800-1500	50
1500-1200	75
1200-900	100
900-600	125

h = THICKNESS OF INSULATION (mm)
 D = DEPTH OF COVER
 W = WIDTH OF INSULATION (mm)
 D = O.D. OF PIPE (mm)

- NOTES:**
- INSULATE ALL SEWER PIPES THAT ARE LESS THAN 600mmØ AND HAVE LESS THAN 1.8m COVER WITH EXPANDED POLYSTYRENE INSULATION AS SHOWN.
 - THE THICKNESS OF INSULATION SHALL BE THE EQUIVALENT OF 25mm FOR EVERY 300mm REDUCTION IN THE REQUIRED DEPTH OF COVER (SEE TABLE)

INSULATION DETAIL FOR SHALLOW SEWERS ONLY
NOT TO SCALE

GENERAL NOTES:

- COORDINATE AND SCHEDULE ALL WORK WITH OTHER TRADES AND CONTRACTORS.
- DETERMINE THE EXACT LOCATION, SIZE, MATERIAL AND ELEVATION OF ALL EXISTING UTILITIES PRIOR TO COMMENCING CONSTRUCTION. PROTECT AND ASSUME RESPONSIBILITY FOR ALL EXISTING UTILITIES WHETHER OR NOT SHOWN ON THIS DRAWING.
- OBTAIN ALL NECESSARY PERMITS AND APPROVALS FROM THE CITY OF OTTAWA BEFORE COMMENCING CONSTRUCTION.
- BEFORE COMMENCING CONSTRUCTION OBTAIN AND PROVIDE PROOF OF COMPREHENSIVE, ALL RISK AND OPERATIONAL LIABILITY INSURANCE FOR \$5,000,000.00. INSURANCE POLICY TO NAME OWNERS, ENGINEERS AND ARCHITECTS AS CO-INSURED.
- COMPLETE ALL WORKS IN ACCORDANCE WITH THE MOST CURRENT CITY OF OTTAWA STANDARDS AND SPECIFICATIONS USING THE CURRENT GUIDELINES, BYLAWS AND STANDARDS INCLUDING MATERIALS OF CONSTRUCTION, DISINFECTION AND ALL RELEVANT REFERENCES TO OPS, OPSD & AWMA GUIDELINES - ALL CURRENT VERSIONS AND AS AMENDED.
- RESTORE ALL DISTURBED AREAS ON-SITE AND OFF-SITE, INCLUDING TRENCHES AND SURFACES ON PUBLIC ROAD ALLOWANCES TO EXISTING CONDITIONS OR BETTER TO THE SATISFACTION OF MUNICIPAL AUTHORITIES.
- REMOVE FROM SITE ALL EXCESS EXCAVATED MATERIAL, ORGANIC MATERIAL AND DEBRIS UNLESS OTHERWISE INSTRUCTED BY ENGINEER. EXCAVATE AND REMOVE FROM SITE ANY CONTAMINATED MATERIAL. ALL CONTAMINATED MATERIAL SHALL BE DISPOSED OF AT A LICENSED LANDFILL FACILITY.
- ALL ELEVATIONS ARE GEODETIC.
- REFER TO GEOTECHNICAL INVESTIGATION REPORT (Ref No.: PG521-1, DATED JAN 20, 2021) PREPARED BY PATERSON GROUP INC. FOR SUBSURFACE CONDITIONS, CONSTRUCTION RECOMMENDATIONS AND GEOTECHNICAL INSPECTION REQUIREMENTS. THE GEOTECHNICAL CONSULTANT IS TO REVIEW ON-SITE CONDITIONS AFTER EXCAVATION PRIOR TO PLACEMENT OF THE GRANULAR MATERIAL.
- REFER TO ARCHITECTS AND LANDSCAPE ARCHITECTS DRAWINGS FOR BUILDING AND HARD SURFACED AREAS AND DIMENSIONS.
- REFER TO THE DEVELOPMENT SERVICING STUDY AND STORMWATER MANAGEMENT REPORT (R-2022-090) PREPARED BY NOVATECH.
- SAW CUT AND KEYGRIND ASPHALT AT ALL ROAD CUTS AND ASPHALT TIE-IN POINTS AS PER CITY OF OTTAWA STANDARDS (R10).

SEWER NOTES:

- SUPPLY AND CONSTRUCT ALL SEWERS AND APPURTENANCES IN ACCORDANCE WITH THE MOST CURRENT CITY OF OTTAWA STANDARDS AND SPECIFICATIONS - ALL CURRENT VERSIONS AND AS AMENDED.
- SPECIFICATIONS:

ITEM	SPEC. No.	REFERENCE
STORM/SANITARY MANHOLE (1200Ø)	701.010	OPSD
STORM/CATCHBASIN MANHOLE (1500Ø)	701.011	OPSD
STORM/CBMH FRAME AND COVER	401.010 - TYPE 'B'	OPSD
SANITARY MANHOLE FRAME AND COVER	401.010 - TYPE 'A'	OPSD
WATERTIGHT MANHOLE FRAME AND COVER	401.030	OPSD
CATCHBASIN MH FRAME & COVER	401.010 Type 'B'	OPSD
CATCHBASIN (600x900)	705.010	OPSD
CATCHBASIN FRAME & COVER	S19	CITY OF OTTAWA
SEWER TRENCH	S6	CITY OF OTTAWA
STORM SEWER	PVC DR 35 (450mmØ PIPE AND SMALLER)	
STORM SEWER	HDPE BOSS 2000 (600mmØ PIPE AND LARGER)	
SANITARY SEWER	PVC DR 35	
- THE SANITARY SERVICE LATERAL SHALL BE EQUIPPED WITH BACKFLOW PREVENTERS WITHIN THE BUILDING FOOTPRINT AS PER CITY OF OTTAWA STANDARD DETAILS S14.1 OR S14.2. REFER TO MECHANICAL PLANS FOR DETAILS.
- THE STORM SERVICE LATERAL SHALL BE EQUIPPED WITH A BACKFLOW PREVENTER WITHIN THE BUILDING FOOTPRINT AS PER CITY OF OTTAWA STANDARD DETAILS S14. REFER TO MECHANICAL PLANS FOR DETAILS.
- SERVICES ARE TO BE CONSTRUCTED TO 1.0m FROM FACE OF BUILDING AT A MINIMUM SLOPE OF 1.0%.
- PIPE BEDDING, COVER AND BACKFILL ARE TO BE COMPACTED TO AT LEAST 95% OF THE STANDARD PROCTOR MAXIMUM DRY DENSITY. THE USE OF CLEAR CRUSHED STONE AS A BEDDING LAYER SHALL NOT BE PERMITTED.
- INSULATE ALL PIPES (SAN / STM) THAT HAVE LESS THAN 1.5m COVER WITH HI-40 INSULATION PER INSULATION DETAIL FOR SHALLOW SEWERS. PROVIDE 150mm CLEARANCE BETWEEN PIPE AND INSULATION.
- CONCRETE MANHOLES ARE TO BE 1200mmØ STRUCTURES UNLESS OTHERWISE NOTED ON THE DRAWING. FLEXIBLE CONNECTIONS ARE REQUIRED FOR CONNECTING PIPES TO MANHOLES (FOR EXAMPLE KOR-N-SEAL, PSX, POSITIVE SEAL AND DURASEAL). THE CONCRETE CRADLE FOR THE PIPE CAN BE ELIMINATED.
- TYPICAL STORM MANHOLES AND CATCHBASIN MANHOLES ARE TO HAVE 300mm SUMP UNLESS OTHERWISE INDICATED.
- THE CONTRACTOR IS TO TELEVISION (CCTV) ALL PROPOSED SEWERS, 200mmØ OR GREATER PRIOR TO BASE COURSE ASPHALT. UPON COMPLETION OF CONTRACT, THE CONTRACTOR IS RESPONSIBLE TO FLUSH AND CLEAN ALL SEWERS & APPURTENANCES. PROVIDE A COPY OF ALL CCTV INSPECTION REPORTS TO THE ENGINEER FOR REVIEW.
- CONTRACTOR TO PROVIDE THE CONSULTANT WITH A GENERAL PLAN OF SERVICES INDICATING ALL APPLICABLE SERVICING AS-BUILT INFORMATION SHOWN ON THIS PLAN. AS-BUILT INFORMATION MUST INCLUDE: PIPE MATERIAL, SIZES, LENGTHS, SLOPES, INVERT AND T/I ELEVATIONS, STRUCTURE LOCATIONS AND ANY ALIGNMENT CHANGES, ETC.
- THE OWNER SHALL REQUIRE THAT THE SITE SERVICING CONTRACTOR PERFORM FIELD TESTS FOR QUALITY CONTROL OF ALL SANITARY SEWERS. LEAKAGE TESTING SHALL BE COMPLETED IN ACCORDANCE WITH OPS 410.07.16, 410.07.16.04 AND 407.07.24. DYE TESTING IS TO BE COMPLETED ON ALL SANITARY SERVICES TO CONFIRM PROPER CONNECTION TO THE SANITARY SEWER MAIN. THE FIELD TESTS SHALL BE PERFORMED IN THE PRESENCE OF A CERTIFIED PROFESSIONAL ENGINEER WHO SHALL SUBMIT A CERTIFIED COPY OF THE TEST RESULTS.

WATERMAIN NOTES:

- SUPPLY AND CONSTRUCT ALL WATERMANS AND APPURTENANCES IN ACCORDANCE WITH THE CITY OF OTTAWA STANDARDS AND SPECIFICATIONS - ALL CURRENT VERSIONS AND AS AMENDED.
- SPECIFICATIONS:

ITEM	SPEC. No.	REFERENCE
WATERMAIN TRENCHING	W17	CITY OF OTTAWA
HYDRANT INSTALLATION	W19	CITY OF OTTAWA
THERMAL INSULATION IN SHALLOW TRENCHES	W22	CITY OF OTTAWA
THERMAL INSULATION BY OPEN STRUCTURES	W23	CITY OF OTTAWA
VALVE BOX ASSEMBLY	W24	CITY OF OTTAWA
WATERMAIN CROSSING BELOW SEWERS	W25	CITY OF OTTAWA
CATHODIC PROTECTION FOR PVC WATERMANS	W40	CITY OF OTTAWA
WATERMAIN MATERIAL	PVC DR 18 (100mm AND LARGER)	
- EXCAVATION, INSTALLATION, BACKFILL AND RESTORATION OF ALL WATERMANS BY THE CONTRACTOR. CONNECTIONS AND SHUT-OFFS AT THE MAIN AND CHLORINATION OF THE WATER SYSTEM SHALL BE PERFORMED BY CITY OFFICIALS.
- WATERMAIN SHALL BE MINIMUM 2.4m DEPTH BELOW GRADE UNLESS OTHERWISE INDICATED.
- PROVIDE MINIMUM 0.5m CLEARANCE BETWEEN OUTSIDE OF PIPES AT ALL CROSSINGS, UNLESS OTHERWISE INDICATED.
- WATER SERVICE IS TO BE CONSTRUCTED TO WITHIN 1.0m OF FOUNDATION WALL AND CAPPED, UNLESS OTHERWISE INDICATED.

PROPOSED 200mmØ / 150mmØ WATER SERVICE TABLE

STATION	SURFACE ELEVATION	T/WM ELEVATION	COMMENTS
0+00.0	82.92a	80.52a	200mmØ WM CONNECTION TO EX. 300mmØ PVC WM
0+009.1	82.95	80.55	VALVE AND VALVE BOX AT PROPERTY LINE
0+011.1	83.03	80.63	CONNECT TO EXISTING WATERMAIN STUB
0+011.8	83.17	80.60	22.5° VERTICAL BEND AS PER CITY DETAIL W25
0+012.9	83.18	80.14	22.5° VERTICAL BEND AS PER CITY DETAIL W25
0+014.1	83.20	80.14	CROSSING BELOW PROPOSED STORM SEWER. CLEARANCE = 0.62m
0+015.3	83.22	80.14	22.5° VERTICAL BEND AS PER CITY DETAIL W25
0+016.4	83.23	80.60	22.5° VERTICAL BEND AS PER CITY DETAIL W25
0+019.1	83.28	80.70	45° HORIZONTAL BEND
0+034.1	83.06	80.66	45° HORIZONTAL BEND
0+063.6	83.24	80.84	45° HORIZONTAL BEND
0+069.4	83.40	81.00	45° HORIZONTAL BEND
0+088.0	83.30	80.90	HYDRANT LEAD (200x150x200 TEE)
0+089.0	83.30	80.90	200x150mm REDUCER
0+090.4	83.35	80.95	45° HORIZONTAL BEND
0+091.4	83.35	80.95	45° HORIZONTAL BEND
0+092.1	83.38	80.98	VALVE AND VALVE BOX
0+093.0	83.38	81.00	CAP 1.0m FROM FOUNDATION WALL

• CONNECTION TO EXISTING 300mmØ PVC WATERMAIN. EXACT ELEVATION TO BE FIELD DETERMINED.

KEY PLAN

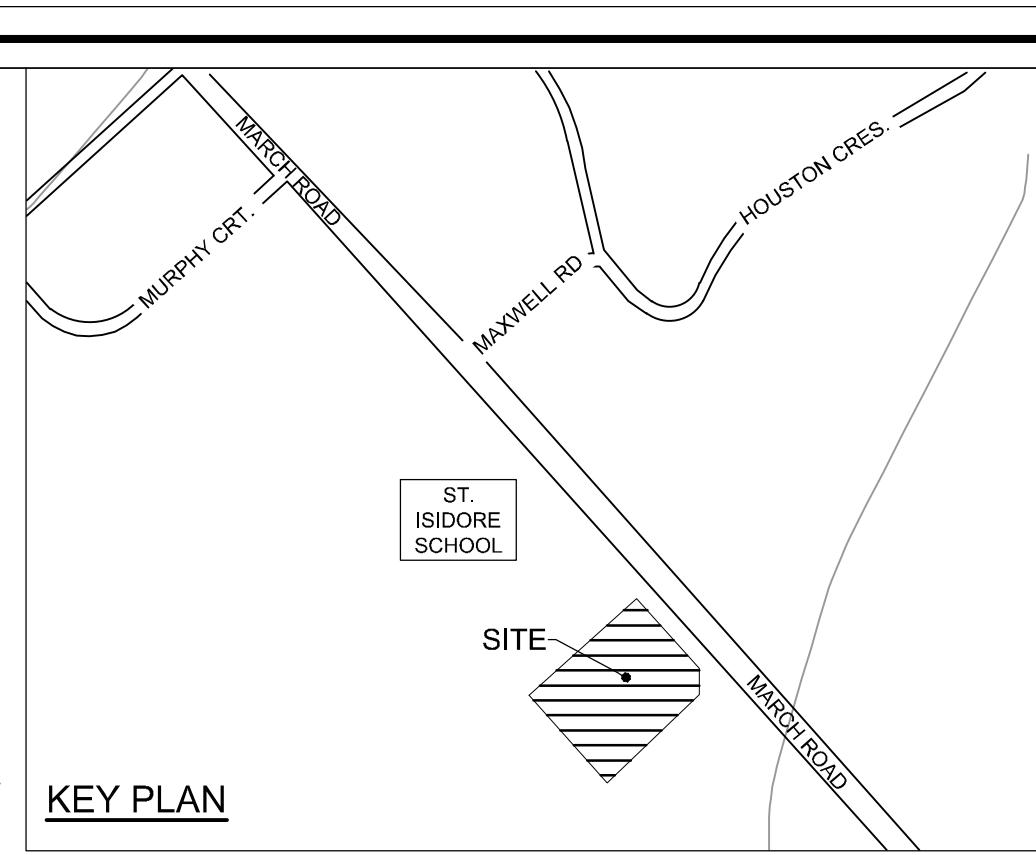

PORTFOLIO DE L'URBANISME ET DE L'INFRASTRUCTURE
 DÉPARTEMENT DES SERVICES D'INFRASTRUCTURE
 DIRECTION DE CONCEPTION ET DE CONSTRUCTION - IMMEUBLES ET DES PARCS

FOR / POUR
INFRASTRUCTURE SERVICES & COMMUNITY SUSTAINABILITY
DESIGN & CONST. - BUILDINGS & PARKS

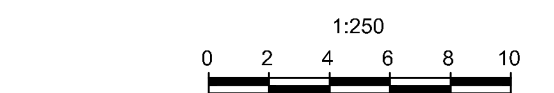

NO.	REVISION	DATE	BY	CHKD
6	REVISED PER CITY COMMENTS	2208/03		FST
5	ISSUED FOR 60% REVIEW	2207/27		FST
3	ISSUED FOR BUILDING PERMIT	2208/15		FST
2	ISSUED FOR 30% REVIEW	2206/20		FST
1	ISSUED FOR SPC APPROVAL	2205/20		FST

DESIGNED BY / CONCEVU PAR	FST/DM	CHECKED BY / VÉRIFIÉ PAR	FST
DRAWN BY / TRACÉ PAR	DMM	SCALE / ÉCHELLE	1:250

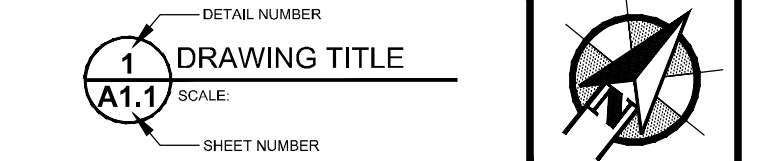

THIS DRAWING IS THE PROPERTY OF THE CITY OF OTTAWA AND ALL COPYRIGHT IS RESERVED. DIMENSIONS ON DRAWING ARE FOR ESTIMATING PURPOSES ONLY. IT IS THE RESPONSIBILITY OF EACH CONTRACTOR AND SUB-CRONTACTOR OR CONSULTANT TO CHECK AND VERIFY ALL DIMENSIONS AND CONDITIONS ON-SITE. NOTIFY OWNER OF ANY ERRORS OR OMISSIONS PRIOR TO COMMENCING THE WORK. DO NOT SCALE THE DRAWINGS.

CE DESSIN CONSTITUE LA PROPRIÉTÉ DE LA VILLE D'OTTAWA ET TOUT DROIT D'AUTEUR EST RÉSERVÉ. LES DIMENSIONS UTILISÉES LE SONT À DES FINS ESTIMATIVES SEULEMENT. IL EST INCOMBE À CHAQUE ENTREPRENEUR, SOUS-CONTRACTANT OU CONSULTANT DE VÉRIFIER TOUTES LES DIMENSIONS ET LES CONDITIONS SUR LE CHANTIER. VEUILLEZ INFORMER LE PROPRIÉTAIRE DE TOUTE ERREUR OU OMISSION AVANT D'ENTAMER LES TRAVAUX. NE DRESSÉZ PAS LES PLANS À L'ÉCHELLE.

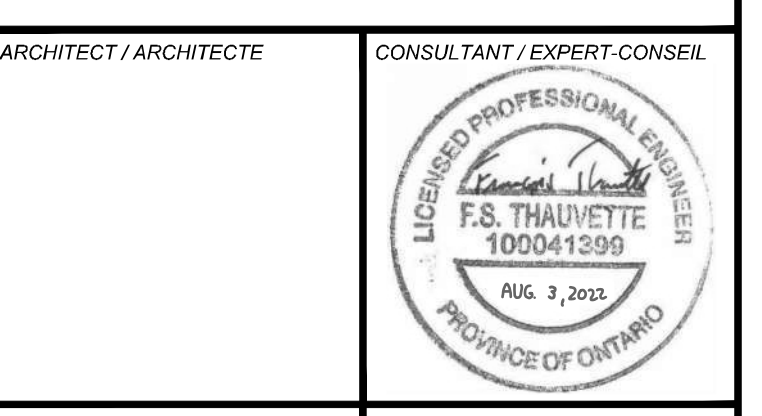

ARCHITECT / ARCHITECTE
 CONSULTANT / EXPERT-CONSEIL

PROJECT / LOCATION / PROJET / ENDROIT
FIRE STATION 45
 1075-A MARCH ROAD
 OTTAWA, ONTARIO

DRAWING / DESSIN
GENERAL PLAN OF SERVICES

BUSINESS ENTITY / NUMÉRO DE L'ENTITÉ
 BUILDING NUMBER / NUMÉRO DU BÂTIMENT

SHEET NO. / FEUILLE No.
C1.0

CITY PROJECT NO. / NUMÉRO DE PROJET
 122089

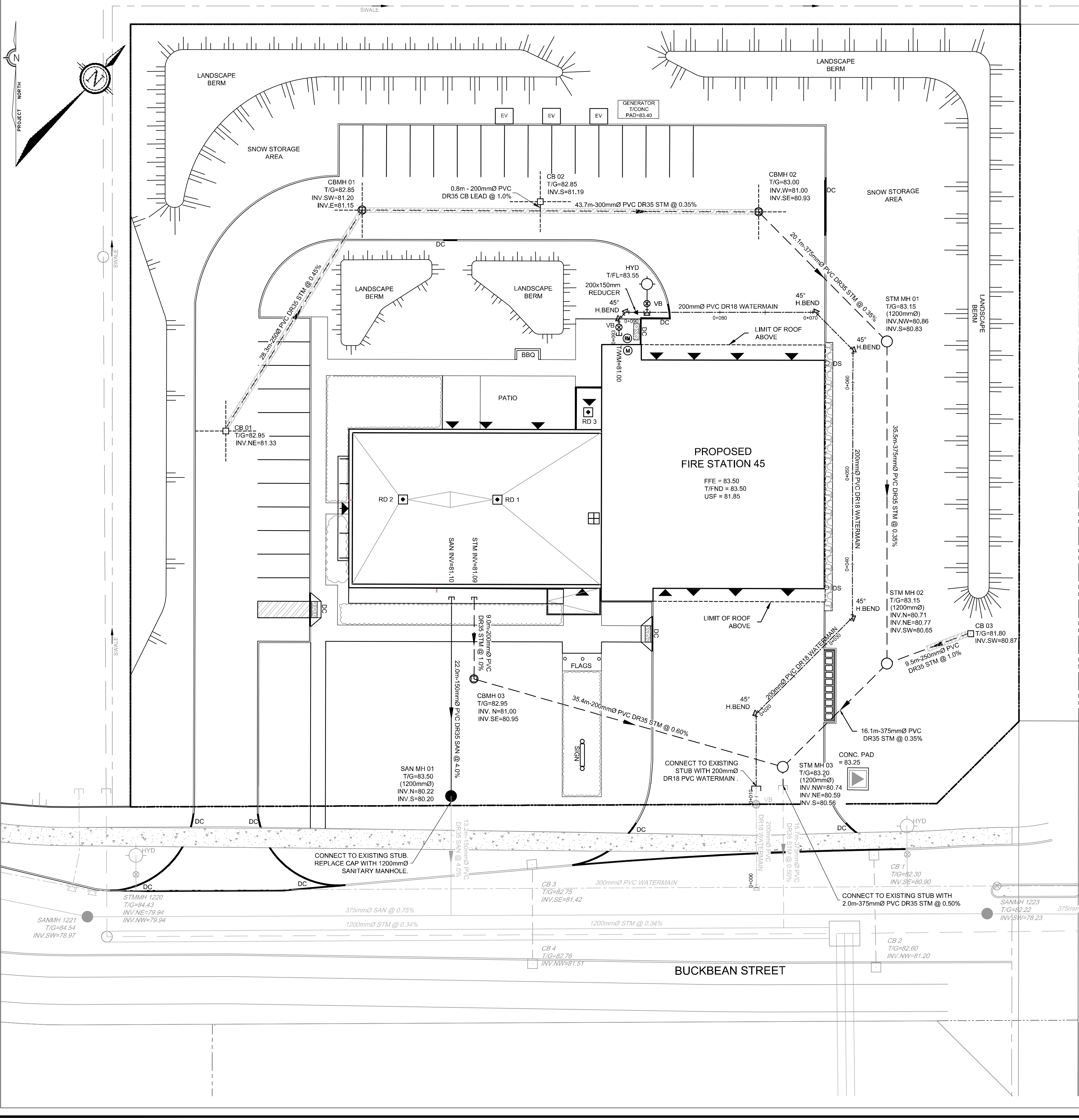

D07-12-22-0090

LEGEND

82.75	PROPOSED ELEVATION	SAN MH 01	PROPOSED SANITARY MANHOLE	EXISTING CONCRETE CURB
83.10 (TC)	PROPOSED TOP OF CURB ELEVATION	STM MH 03	PROPOSED STORM MANHOLE	EXISTING CATCHBASIN
82.30(S)	PROPOSED SWALE ELEVATION	HYD	PROPOSED HYDRANT AND VALVE	EXISTING CATCHBASIN/INLET
82.30	EXISTING STREET / GRADES	CBMH 01	PROPOSED CATCHBASIN MANHOLE	EXISTING UTILITY POLE
82.30	EXISTING ELEVATION	CB 02	PROPOSED CATCHBASIN	EXISTING FENCE
2.0%	GRADE AND DIRECTION		PROPOSED CATCHBASIN INSERT	EXISTING OVERHEAD WIRES
	MAXIMUM 3:1 SIDESLOPE		EMERGENCY OVERLAND FLOW ROUTE	EXISTING VALVE & VALVE BOX
83.50	PROPOSED TERRACE ELEVATION		BUILDING ENTRANCE / EXIT	
	PROPOSED SILT FENCING (OPSD 219.110)		TRANSFORMER	
	PROPERTY LINE	DS	DOWNSPOUT	
	FFE FINISHED FLOOR ELEVATION	SP	EXISTING SERVICE POST	
	T/FND TOP OF FOUNDATION WALL ELEVATION	HYD	EXISTING HYDRANT	
	USF UNDERSIDE OF FOOTING ELEVATION			

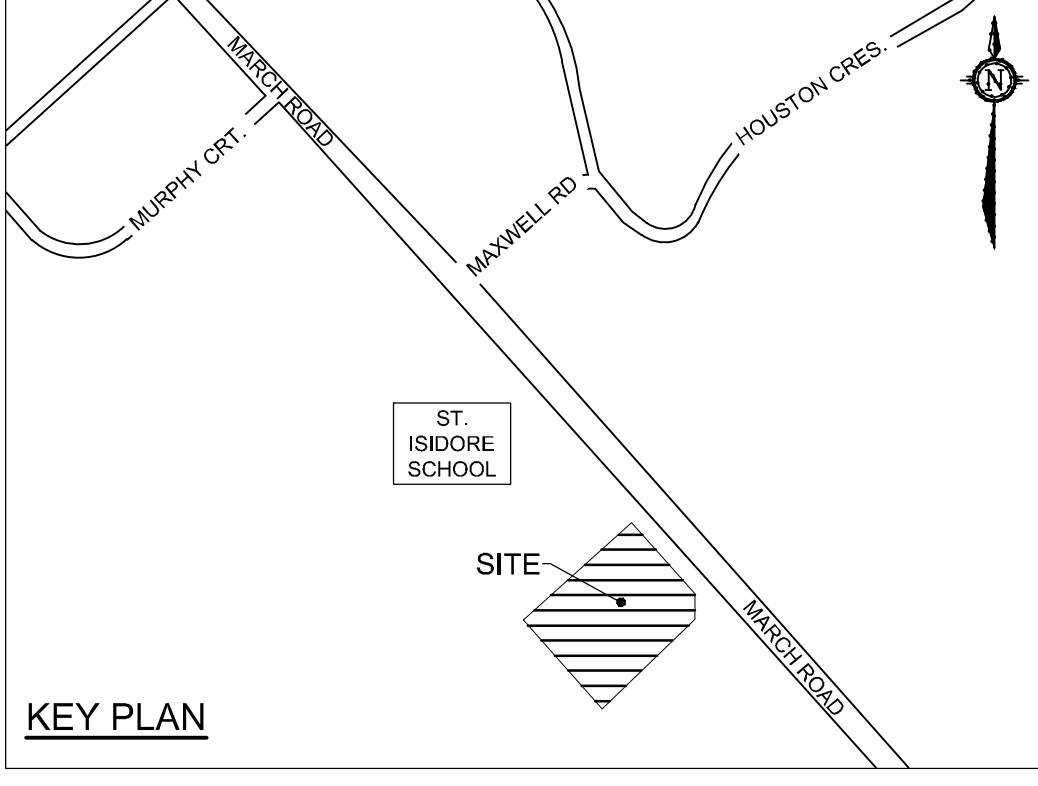
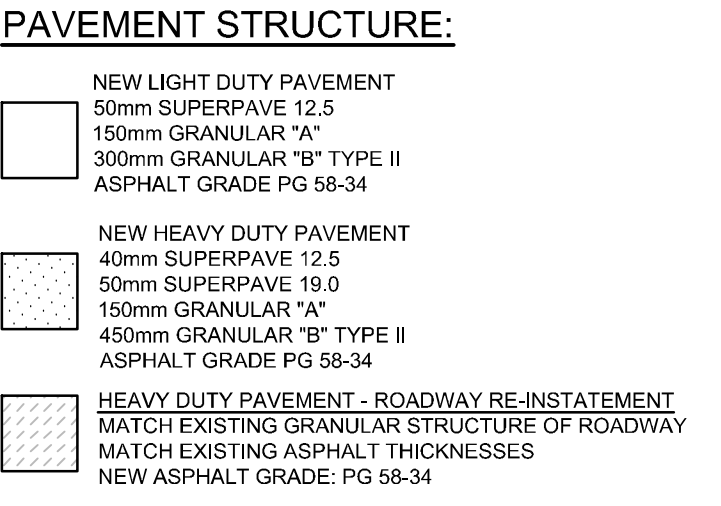
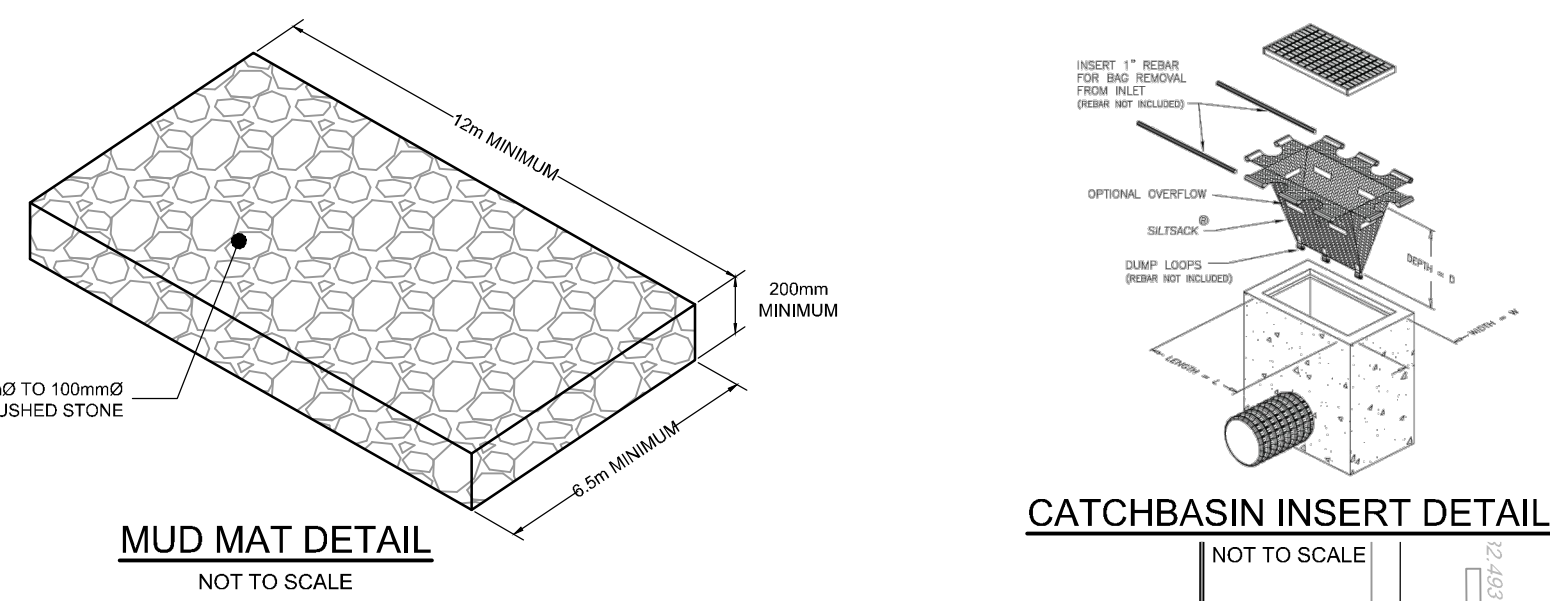

- GENERAL NOTES:**
- COORDINATE AND SCHEDULE ALL WORK WITH OTHER TRADES AND CONTRACTORS.
 - DETERMINE THE EXACT LOCATION, SIZE, MATERIAL AND ELEVATION OF ALL EXISTING UTILITIES PRIOR TO COMMENCING CONSTRUCTION. PROTECT AND ASSUME RESPONSIBILITY FOR ALL EXISTING UTILITIES WHETHER OR NOT SHOWN ON THIS DRAWING.
 - OBTAIN ALL NECESSARY PERMITS AND APPROVALS FROM THE CITY OF OTTAWA BEFORE COMMENCING CONSTRUCTION.
 - BEFORE COMMENCING CONSTRUCTION OBTAIN AND PROVIDE PROOF OF COMPREHENSIVE, ALL RISK AND OPERATIONAL LIABILITY INSURANCE FOR \$5,000,000.00. INSURANCE POLICY TO NAME OWNERS, ENGINEERS AND ARCHITECTS AS CO-INSURED.
 - COMPLETE ALL WORKS IN ACCORDANCE WITH THE MOST CURRENT CITY OF OTTAWA STANDARDS AND SPECIFICATIONS USING THE CURRENT GUIDELINES. BYLAWS AND STANDARDS INCLUDING MATERIALS OF CONSTRUCTION, DISINFECTION AND ALL RELEVANT REFERENCES TO OPSS, OPSD & AWWA GUIDELINES - ALL CURRENT VERSIONS AND AS AMENDED.
 - RESTORE ALL DISTURBED AREAS ON-SITE AND OFF-SITE, INCLUDING TRENCHES AND SURFACES ON PUBLIC ROAD ALLOWANCES TO EXISTING CONDITIONS OR BETTER TO THE SATISFACTION OF THE CITY OF OTTAWA AND ENGINEER.
 - REMOVE FROM SITE ALL EXCESS EXCAVATED MATERIAL, ORGANIC MATERIAL AND DEBRIS UNLESS OTHERWISE INSTRUCTED BY ENGINEER. EXCAVATE AND REMOVE FROM SITE ANY CONTAMINATED MATERIAL. ALL CONTAMINATED MATERIAL SHALL BE DISPOSED OF AT A LICENSED LANDFILL FACILITY.
 - ALL ELEVATIONS ARE GEODETIC.
 - REFER TO GEOTECHNICAL INVESTIGATION REPORT (Ref No: PG5321-1, DATED JAN 20, 2021), PREPARED BY PATERSON GROUP INC., FOR SUBSURFACE CONDITIONS, CONSTRUCTION RECOMMENDATIONS, AND GEOTECHNICAL INSPECTION REQUIREMENTS. THE GEOTECHNICAL CONSULTANT IS TO REVIEW ON-SITE CONDITIONS AFTER EXCAVATION PRIOR TO PLACEMENT OF THE GRANULAR MATERIAL.
 - REFER TO ARCHITECT'S AND LANDSCAPE ARCHITECT'S DRAWINGS FOR BUILDING AND HARDSURFACE AREAS AND DIMENSIONS.
 - REFER TO THE DEVELOPMENT SERVICING STUDY AND STORMWATER MANAGEMENT REPORT (R-2022-090) PREPARED BY NOVATECH.
 - SAW CUT AND KEY GRIND ASPHALT AT ALL ROAD CUTS AND ASPHALT TIE IN POINTS AS PER CITY OF OTTAWA STANDARDS (R10).

- GRADING NOTES:**
- ALL TOPSOIL, ORGANIC OR DELETERIOUS MATERIAL MUST BE ENTIRELY REMOVED FROM BENEATH THE PROPOSED PAVED AREAS AS DIRECTED BY THE SITE ENGINEER OR GEOTECHNICAL ENGINEER.
 - EXPOSED SUBGRADES IN PROPOSED PAVED AREAS SHOULD BE PROOF ROLLED WITH A LARGE STEEL DRUM ROLLER AND INSPECTED BY THE GEOTECHNICAL ENGINEER PRIOR TO THE PLACEMENT OF GRANULARS.
 - ANY SOFT AREAS EVIDENT FROM THE PROOF ROLLING SHOULD BE SUB-EXCAVATED AND REPLACED WITH SUITABLE MATERIAL THAT IS FROST COMPATIBLE WITH THE EXISTING SOILS AS RECOMMENDED BY THE GEOTECHNICAL ENGINEER.
 - THE GRANULAR BASE SHOULD BE COMPACTED TO AT LEAST 98% OF THE STANDARD PROCTOR MAXIMUM DRY DENSITY VALUE. ANY ADDITIONAL GRANULAR FILL USED BELOW THE PROPOSED PAVEMENT SHOULD BE COMPACTED TO AT LEAST 95% OF THE STANDARD PROCTOR MAXIMUM DRY DENSITY VALUE.
 - MINIMUM OF 2% GRADE FOR ALL GRASS AREAS UNLESS OTHERWISE NOTED.
 - MAXIMUM TERRACING GRADE TO BE 3:1 UNLESS OTHERWISE NOTED.
 - ALL GRADES BY CURBS ARE EDGE OF PAVEMENT GRADES UNLESS OTHERWISE INDICATED.
 - ALL CURBS SHALL BE BARRIER CURB (150mm) UNLESS OTHERWISE NOTED AND CONSTRUCTED AS PER CITY OF OTTAWA STANDARDS (SC1.1).
 - REFER TO LANDSCAPE PLAN FOR PLANTING AND OTHER LANDSCAPE FEATURE DETAILS.
 - CONTRACTOR TO PROVIDE THE CONSULTANT WITH A GRADING PLAN INDICATING THE AS-BUILT ELEVATIONS OF ALL DESIGN GRADES SHOWN ON THIS PLAN.

- EROSION AND SEDIMENT CONTROL NOTES:**
- ALL EROSION AND SEDIMENT CONTROL MEASURES ARE TO BE INSTALLED TO THE SATISFACTION OF THE ENGINEER AND THE CITY OF OTTAWA. THEY ARE TO BE APPROPRIATE TO THE SITE CONDITIONS, PRIOR TO UNDERTAKING ANY SITE ALTERATIONS (FILLING, GRADING, REMOVAL OF VEGETATION, ETC.) AND DURING ALL PHASES OF SITE PREPARATION AND CONSTRUCTION. THESE PRACTICES ARE TO BE IMPLEMENTED IN ACCORDANCE WITH THE CURRENT BEST MANAGEMENT PRACTICES FOR EROSION AND SEDIMENT CONTROL AND SHOULD INCLUDE AS A MINIMUM THOSE MEASURES INDICATED ON THE PLAN.
 - A LIGHT DUTY SILT FENCE BARRIER WILL ALSO BE INSTALLED AROUND THE CONSTRUCTION AREA (WHERE APPLICABLE). THESE CONTROL MEASURES WILL REMAIN IN PLACE UNTIL CONSTRUCTION IS COMPLETE.
 - TO PREVENT SURFACE EROSION FROM ENTERING ANY STORM SEWER SYSTEM DURING CONSTRUCTION, CATCHBASIN INSERTS WILL BE PLACED WITHIN SURFACE CATCHBASINS AND MANHOLE STRUCTURES. A LIGHT DUTY SILT FENCE BARRIER WILL ALSO BE INSTALLED (PER OPSD 219.110) AROUND THE CONSTRUCTION AREA (WHERE APPLICABLE). IN AREAS WHERE SILT FENCING CANNOT BE INSTALLED PER OPSD 219.110 (i.e. HARD SURFACES), A FILTER SOCK SHALL BE SUBSTITUTED. THESE CONTROL MEASURES WILL REMAIN IN PLACE UNTIL CONSTRUCTION IS COMPLETE.
 - THE SEDIMENT CONTROL MEASURES SHALL ONLY BE REMOVED WHEN, IN THE OPINION OF THE ENGINEER, THE MEASURES ARE NO LONGER REQUIRED. NO CONTROL MEASURES MAY BE PERMANENTLY REMOVED WITHOUT PRIOR AUTHORIZATION FROM THE ENGINEER.
 - THE CONTRACTOR SHALL IMMEDIATELY REPORT TO THE ENGINEER ANY ACCIDENTAL DISCHARGES OF SEDIMENT MATERIAL INTO ANY STORM SEWER SYSTEM. APPROPRIATE RESPONSE MEASURES, INCLUDING ANY REPAIRS TO EXISTING CONTROL MEASURES OR THE IMPLEMENTATION OF ADDITIONAL CONTROL MEASURES, SHALL BE CARRIED OUT BY THE CONTRACTOR WITHOUT DELAY.
 - THE CONTRACTOR ACKNOWLEDGES THAT FAILURE TO IMPLEMENT EROSION AND SEDIMENT CONTROL MEASURES MAY BE SUBJECT TO PENALTIES IMPOSED BY ANY APPLICABLE REGULATORY AGENCY.
 - ROADWAYS ARE TO BE SWEEP AS REQUIRED OR AS DIRECTED BY THE ENGINEER AND/OR MUNICIPALITY.
 - THE CONTRACTOR SHALL ENSURE PROPER DUST CONTROL IS PROVIDED WITH THE APPLICATION OF WATER (AND IF REQUIRED, CALCIUM CHLORIDE) DURING DRY PERIODS.

Erosion and Sediment Control Responsibilities:

ESC Measure	Symbol	Specification	During Construction		After Construction Prior to Final Acceptance		After Final Acceptance	
			Installation Responsibility	Inspection/Maintenance Responsibility	Approval to Remove	Removal Responsibility	Inspection/Maintenance Responsibility	
Silt Fence	---	OPSD 219.110	Developer's Contractor	Developer's Contractor	Consultant	Developer's Contractor		N/A
Filter Bags/Socks	---	Location as indicated in EGC Notes #1	Developer's Contractor	Developer's Contractor	Consultant	Developer's Contractor		N/A
Mud Mat	---	Drawing Details	Developer's Contractor	Developer's Contractor	Developer's Contractor	Developer's Contractor		N/A
Dust Control	---	Location as Required	Developer's Contractor	Developer's Contractor	Consultant	Developer's Contractor		N/A
Stabilized Material Stockpiling	---	Location as Required by Contractor	Developer's Contractor	Developer's Contractor	Developer's Contractor	Developer's Contractor		N/A
Sediment Basin (for flows being pumped out of excavations)	---	Location as Required by Contractor	Developer's Contractor	Developer's Contractor	After Every Rainstorm	Developer's Contractor	Developer's Contractor	N/A

Ottawa

PLANNING AND INFRASTRUCTURE PORTFOLIO
INFRASTRUCTURE SERVICES DEPARTMENT
DESIGN AND CONSTRUCTION - BUILDINGS & PARKS BRANCH

PORTFEUILLE DE L'URBANISME ET DE L'INFRASTRUCTURE
DÉPARTEMENT DES SERVICES D'INFRASTRUCTURE
DIRECTION DE CONCEPTION ET DE CONSTRUCTION - IMMEUBLES ET DES PARCS

FOR / POUR
INFRASTRUCTURE SERVICES & COMMUNITY SUSTAINABILITY
INFRASTRUCTURE SERVICES
DESIGN & CONST. - BUILDINGS & PARKS

1:250
0 2 4 6 8 10

NOVATECH

Engineers, Planners & Landscape Architects

Suite 200, 240 Michael Cowland Drive
Ottawa, Ontario, Canada K2M 1P6
Telephone: (613) 234-9643
Facsimile: (613) 234-9661
Website: www.novatech-eng.com

NUMBER	REVISION / MILESTONE / FMT SAILLANT	DATE: (Y/M/D)	INITIALS: (NAME)
6	REVISED PER CITY COMMENTS	22/08/23	FST
4	ISSUED FOR 60% REVIEW	22/07/22	FST
3	ISSUED FOR BUILDING PERMIT	22/07/15	FST
2	ISSUED FOR 30% REVIEW	22/06/20	FST
1	ISSUED FOR SPC APPROVAL	22/05/20	FST

DESIGNED BY: VERITE PAR
SCALE: 1:250
DMM

DRAWING TITLE

1:1 SCALE

111 SHEET NUMBER

THIS DRAWING IS THE PROPERTY OF THE CITY OF OTTAWA AND ALL COPYRIGHT IS RESERVED. DIMENSIONS ON DRAWINGS ARE FOR ESTIMATING PURPOSES ONLY. IT IS THE RESPONSIBILITY OF EACH CONTRACTOR AND SUB-CONTRACTOR OR CONSULTANT TO CHECK AND VERIFY ALL DIMENSIONS AND CONDITIONS ON SITE. NOTIFY OWNER OF ANY ERRORS OR OMISSIONS PRIOR TO COMMENCING THE WORK. DO NOT SCALE THE DRAWINGS.

CE DESSIN CONSTITUE LA PROPRIÉTÉ DE LA VILLE D'OTTAWA ET TOUT DROIT D'AUTEUR EST RÉSERVÉ. LES DIMENSIONS UTILISÉES LES SONT À DES FINS DESTINÉES À ESTIMER SEULEMENT. IL INCOMBE À CHAQUE ENTREPRENEUR, SOUS-CONTRACTANT OU CONSULTANT DE VÉRIFIER TOUTES LES DIMENSIONS ET LES CONDITIONS SUR LE CHANTIER. VEUILLEZ INFORMER LE PROPRIÉTAIRE DE TOUTES ERREURS OU OMISSIONS AVANT D'ENTAMER LES TRAVAUX. NE DRESSÉZ PAS LES PLANS À L'ÉCHELLE.

ARCHITECT / ARCHITECTE
CONSULTANT / EXPERT-CONSEIL

CONSULTANT / EXPERT-CONSEIL
CONSULTANT / EXPERT-CONSEIL

PROFESSEUR D'INGÉNIEUR
F.S. THAUETTE
100041299
AUG 2, 2022
PROVINCE OF ONTARIO

PROJECT / LOCATION / PROJET / ENDROIT
FIRE STATION 45

1075-A MARCH ROAD
OTTAWA, ONTARIO

DRAWING / DESSIN
**GRADING AND EROSION
SEDIMENT CONTROL PLAN**

BUSINESS ENTITY / NUMÉRO DE L'ENTITÉ
BUILDING NUMBER / NUMÉRO DU BÂTIMENT

SHEET NO. / FEUILLE NO.
C2.0

CITY PROJECT NO. / NO. DE PROJET
122089

CONS. PROJECT NO. / NO. DE PROJET

D07-12-22-0090

LEGEND

- PROPOSED BARRIER CURB
- DC PROPOSED DEPRESSED CURB
- DRAINAGE AREA LIMITS
- A-1
0.114
0.80 POST-DEVELOPMENT AREA ID
- POST-DEVELOPMENT DRAINAGE AREA (ha)
- 1:5 YEAR WEIGHTED RUNOFF COEFFICIENT
- MAXIMUM 3:1 SIDESLOPE
- 83.50 PROPOSED TERRACE ELEVATION
- SAN MH 01
- STM MH 03
- HYD
- CBMH 01
- CB 02
- EMERGENCY OVERLAND FLOW ROUTE
- FFE
- PROPOSED SANITARY MANHOLE
- PROPOSED STORM MANHOLE
- PROPOSED HYDRANT AND VALVE
- PROPOSED CATCHBASIN MANHOLE
- PROPOSED CATCHBASIN
- PROPOSED CATCHBASIN
- PROPOSED CATCHBASIN
- EMERGENCY OVERLAND FLOW ROUTE
- PROPOSED HYDRO TRANSFORMER
- FINISHED FLOOR ELEVATION
- T/FND TOP OF FOUNDATION WALL ELEVATION
- USF UNDERSIDE OF FOOTING ELEVATION
- BUILDING ENTRANCE / EXIT
- EXISTING CONCRETE CURB
- EXISTING VALVE & VALVE BOX
- EXISTING SERVICE POST
- EXISTING HYDRANT
- EXISTING CATCHBASIN
- EXISTING CATCHBASIN MH
- EXISTING UTILITY POLE
- CW GUY WIRES
- APPROXIMATE PONDING LIMITS
- 1.5 YR
- 1:100 YR

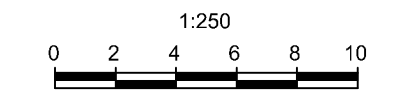
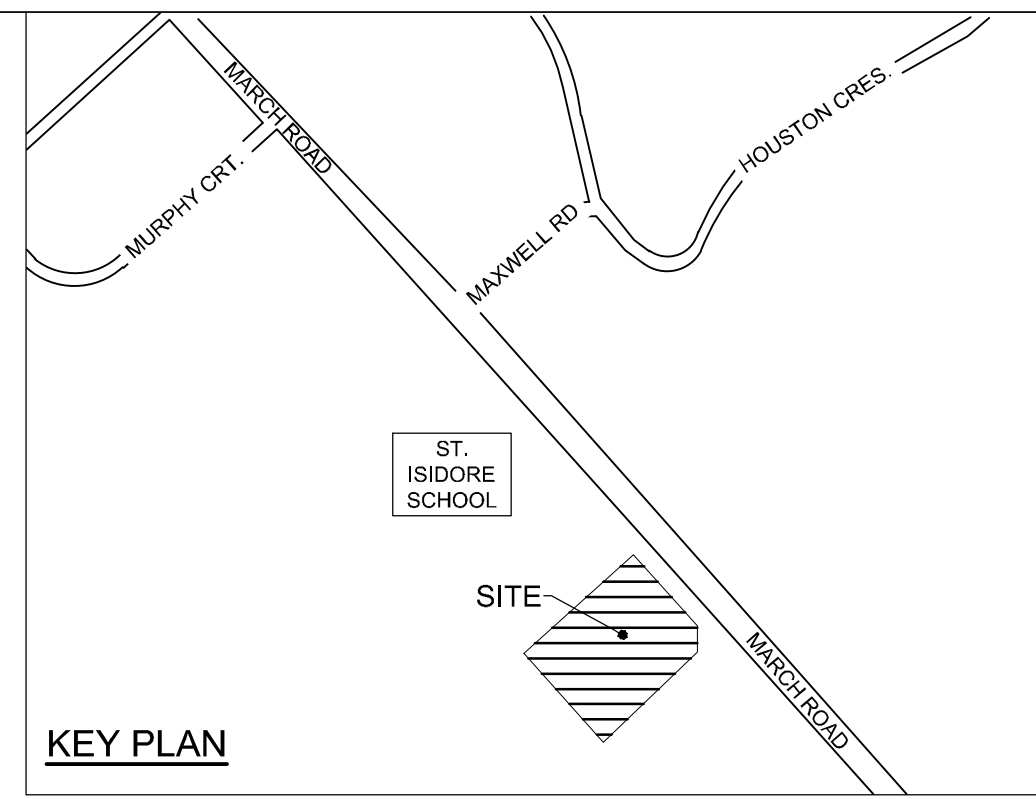
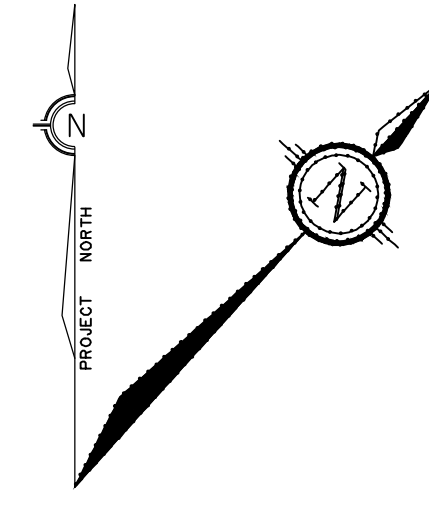

GENERAL NOTES:

1. COORDINATE AND SCHEDULE ALL WORK WITH OTHER TRADES AND CONTRACTORS.
2. DETERMINE THE EXACT LOCATION, SIZE, MATERIAL AND ELEVATION OF ALL EXISTING UTILITIES PRIOR TO COMMENCING CONSTRUCTION. PROTECT AND ASSUME RESPONSIBILITY FOR ALL EXISTING UTILITIES WHETHER OR NOT SHOWN ON THIS DRAWING.
3. OBTAIN ALL NECESSARY PERMITS AND APPROVALS FROM THE CITY OF OTTAWA BEFORE COMMENCING CONSTRUCTION.
4. BEFORE COMMENCING CONSTRUCTION OBTAIN AND PROVIDE PROOF OF COMPREHENSIVE, ALL RISK AND OPERATIONAL LIABILITY INSURANCE FOR \$5,000,000.00. INSURANCE POLICY TO NAME OWNERS, ENGINEERS AND ARCHITECTS AS CO-INSURED.
5. COMPLETE ALL WORKS IN ACCORDANCE WITH THE MOST CURRENT CITY OF OTTAWA STANDARDS AND SPECIFICATIONS USING THE CURRENT GUIDELINES, BYLAWS AND STANDARDS INCLUDING MATERIALS OF CONSTRUCTION, DISINFECTION AND ALL RELEVANT REFERENCES TO OPSS, OPSD & AWWA GUIDELINES - ALL CURRENT VERSIONS AND 'AS AMENDED'.
6. RESTORE ALL DISTURBED AREAS ON-SITE AND OFF-SITE, INCLUDING TRENCHES AND SURFACES ON PUBLIC ROAD ALLOWANCES TO EXISTING CONDITIONS OR BETTER TO THE SATISFACTION OF THE CITY OF OTTAWA AND ENGINEER.
7. REMOVE FROM SITE ALL EXCESS EXCAVATED MATERIAL, ORGANIC MATERIAL AND DEBRIS UNLESS OTHERWISE INSTRUCTED BY ENGINEER. EXCAVATE AND REMOVE FROM SITE ANY CONTAMINATED MATERIAL. ALL CONTAMINATED MATERIAL SHALL BE DISPOSED OF AT A LICENSED LANDFILL FACILITY.
8. ALL ELEVATIONS ARE GEODETIC.
9. REFER TO GEOTECHNICAL INVESTIGATION REPORT (Ref.No.: PG5321-1, DATED JAN 20, 2021), PREPARED BY PATERSON GROUP INC., FOR SUBSURFACE CONDITIONS, CONSTRUCTION RECOMMENDATIONS, AND GEOTECHNICAL INSPECTION REQUIREMENTS. THE GEOTECHNICAL CONSULTANT IS TO REVIEW ON-SITE CONDITIONS AFTER EXCAVATION PRIOR TO PLACEMENT OF THE GRANULAR MATERIAL.
10. REFER TO ARCHITECTS' AND LANDSCAPE ARCHITECTS' DRAWINGS FOR BUILDING AND HARDSURFACE AREAS AND DIMENSIONS.
11. REFER TO THE DEVELOPMENT SERVICING STUDY AND STORMWATER MANAGEMENT REPORT (R-2022-090) PREPARED BY NOVATECH.
12. SAW CUT AND KEY GRIND ASPHALT AT ALL ROAD CUTS AND ASPHALT TIE IN POINTS AS PER CITY OF OTTAWA STANDARDS (R10).

PROPOSED SITE FLOWS & STORMWATER MANAGEMENT TABLE

DESIGN EVENT	PRE-DEVELOPMENT CONDITIONS		POST-DEVELOPMENT CONDITIONS				
	ALLOWABLE RELEASE RATE (L/s)	A-0 DIRECT RUNOFF (L/s)	A-1 TO A-6 UNCONTROLLED FLOW (L/s)	A-7 DIRECT RUNOFF (L/s)	R-1 CONTROLLED FLOW (L/s)	TOTAL FLOW (L/s)	REDUCTION IN FLOW (L/s or %)
1:5 YR	221.9	14.6	93.0	2.7	2.4	112.7	109.2 or 49%
1:100 YR		28.2	182.4	5.7	3.3	219.6	2.3 or 0.5%

PROPOSED ROOF DRAIN TABLE: AREA R-1 (RD1, RD2 AND RD3)

AREA ID	ROOF DRAIN No. (WATTS MODEL)	ROOF DRAIN OPENING SETTING	1.5 YEAR RELEASE RATE	APPROX. 5-YR PONDING DEPTH	1:100 YEAR RELEASE RATE	APPROX. 100-YR PONDING DEPTH
R-1	RD 1 (RD-100-A-ADJ)	FULLY EXPOSED	1.07 L/s	9 cm	1.39 L/s	12 cm
R-1	RD 2 (RD-100-A-ADJ)	FULLY EXPOSED	1.07 L/s	9 cm	1.39 L/s	12 cm
R-1	RD 3 (RD-100-A-ADJ)	-	0.26 L/s	-	0.50 L/s	-

* REFER TO THE DEVELOPMENT SERVICING STUDY AND STORMWATER MANAGEMENT REPORT (R-2022-090) PREPARED BY NOVATECH FOR DRAINAGE AREA IDENTIFIERS AND STORMWATER MANAGEMENT DETAILS.

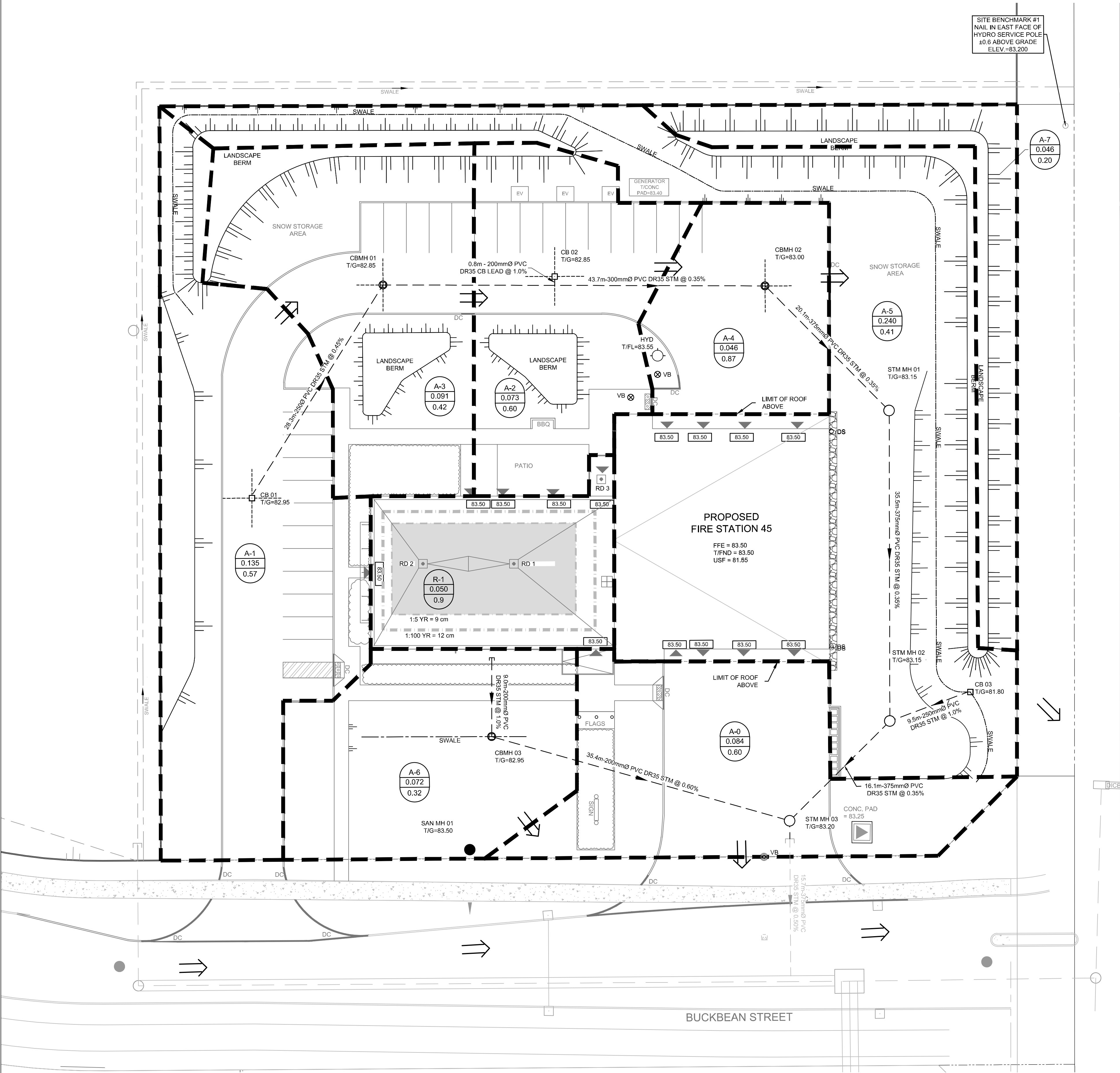

MARCH ROAD

BUCKBEAN STREET

NO.	REVISION	DATE	BY	CHKD
1	ISSUED FOR SPC APPROVAL	220520	FST	
2	ISSUED FOR 30% REVIEW	220520	FST	
3	REVISED PER CITY COMMENTS	220603	FST	
4				
5				
6				

DESIGNED BY / CONCEVUE PAR	FST	CHECKED BY / VERIFIE PAR	
DATE / DATE DE DESSIN PAR		SCALE / ÉCHELLE	1:250
DRAWING NUMBER		SHEET NUMBER	

THIS DRAWING IS THE PROPERTY OF THE CITY OF OTTAWA AND ALL COPYRIGHT IS RESERVED. DIMENSIONS ON DRAWING ARE FOR ESTIMATING PURPOSES ONLY. IT IS THE RESPONSIBILITY OF EACH CONTRACTOR AND SUB-CONTRACTOR OR CONSULTANT TO CHECK AND VERIFY ALL DIMENSIONS AND CONDITIONS ON SITE. NOTIFY OWNER OF ANY ERRORS OR OMISSIONS PRIOR TO COMMENCING THE WORK. DO NOT SCALE THE DRAWINGS.

CE DESSIN CONSTITUE LA PROPRIÉTÉ DE LA VILLE D'OTTAWA ET TOUT DROIT D'AUTEUR EST RÉSERVÉ. LES DIMENSIONS UTILISÉES LE SONT À DES FINS D'ESTIMATION SEULEMENT. IL INCOMBE À CHAQUE ENTREPRENEUR, SOUS-CONTRACTANT OU CONSULTANT DE VÉRIFIER TOUTES LES DIMENSIONS ET LES CONDITIONS SUR LE CHANTIER. VEUILLEZ INFORMER LE PROPRIÉTAIRE DE TOUTE ERREUR OU OMISSION AVANT D'ENTAMER LES TRAVAUX. NE DRESSER PAS LES PLANS À L'ÉCHELLE.

ARCHITECT / ARCHITECTE

CONSULTANT / EXPERT-CONSEIL

F.S. THAUETTE
 100041399
 AUG 3, 2022
 PROVINCE OF ONTARIO

CONSULTANT / EXPERT-CONSEIL

CONSULTANT / EXPERT-CONSEIL

PROJECT / LOCATION / PROJET / ENDROIT

FIRE STATION 45

1075-A MARCH ROAD
 OTTAWA, ONTARIO

DRAWING / DESSIN

STORMWATER MANAGEMENT PLAN