



**1300 McWatters Road –  
Servicing and Stormwater  
Management Report**

Stantec Project No. 160401668

July 20, 2022

Prepared for:

Homestead Land Holdings Limited  
80 Johnson Street  
Kingston, ON, K7L 1X7

Prepared by:

Stantec Consulting Ltd.  
300-1331 Clyde Avenue  
Ottawa ON K2C 3G4



<b>Revision</b>	<b>Description</b>	<b>Author</b>		<b>Quality Check</b>		<b>Independent Review</b>	
0	1 <sup>st</sup> Submission - SPA	NN	2022-02-28	KS	2022-02-28	SG	2022-01-03
0	2 <sup>nd</sup> Submission - SPA	NN	2022-07-19	KS	2022-07-20	SG	2022-07-20



## 1300 MCWATTERS ROAD –SERVICING AND STORMWATER MANAGEMENT REPORT

This document entitled 1300 McWatters Road –Servicing and Stormwater Management Report was prepared by Stantec Consulting Ltd. (“Stantec”) for the account of Homestead Land Holdings Limited (the “Client”). Any reliance on this document by any third party is strictly prohibited. The material in it reflects Stantec’s professional judgment in light of the scope, schedule and other limitations stated in the document and in the contract between Stantec and the Client. The opinions in the document are based on conditions and information existing at the time the document was published and do not take into account any subsequent changes. In preparing the document, Stantec did not verify information supplied to it by others. Any use which a third party makes of this document is the responsibility of such third party. Such third party agrees that Stantec shall not be responsible for costs or damages of any kind, if any, suffered by it or any other third party as a result of decisions made or actions taken based on this document.

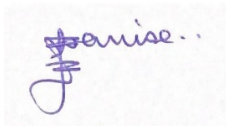

Prepared by \_\_\_\_\_

**Nwanise Nwanise, EIT**



Reviewed by \_\_\_\_\_

**Smadella Karin, P.Eng**

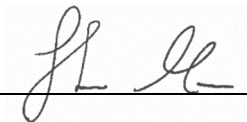

Approved by \_\_\_\_\_

**Sheridan Gillis**



**Table of Contents**

**1.0 INTRODUCTION.....1.1**

1.1 OBJECTIVE ..... 1.2

**2.0 REFERENCES.....2.1**

**3.0 POTABLE WATER SERVICING .....3.2**

3.1 BACKGROUND .....3.2

3.2 WATER DEMANDS .....3.2

3.2.1 Domestic Water Demands..... 3.2

3.2.2 Fire Flow Demands ..... 3.3

3.2.3 Boundary Conditions ..... 3.3

3.2.4 Proposed servicing ..... 3.4

**4.0 WASTEWATER SERVICING .....4.1**

**5.0 STORMWATER MANAGEMENT AND SERVICING .....5.2**

5.1 OBJECTIVES..... 5.2

5.2 EXISTING CONDITIONS AND SWM CRITERIA..... 5.2

5.3 STORMWATER MANAGEMENT DESIGN..... 5.3

5.3.1 Design Methodology ..... 5.3

5.3.2 Allowable Release Rate ..... 5.3

5.3.3 Stormwater Quantity Control ..... 5.4

5.3.4 Storage Requirements..... 5.4

5.3.5 Uncontrolled Area ..... 5.5

5.3.6 Results..... 5.5

5.3.7 Stormwater Quality Control ..... 5.7

**6.0 GRADING AND DRAINAGE .....6.1**

**7.0 UTILITIES .....7.1**

**8.0 EROSION CONTROL DURING CONSTRUCTION.....8.2**

**9.0 GEOTECHNICAL INVESTIGATION .....9.3**

**10.0 APPROVALS/PERMITS .....10.5**

**11.0 CONCLUSIONS.....11.1**

11.1 POTABLE WATER SERVICING..... 11.1

11.2 WASTEWATER SERVICING..... 11.1

11.3 STORMWATER MANAGEMENT AND SERVICING ..... 11.1

11.4 GRADING ..... 11.1

11.5 UTILITIES ..... 11.1

11.6 APPROVALS/PERMITS ..... 11.2



**LIST OF TABLES**

Table 3–1: Estimated Water Demands ..... 3.3  
 Table 3–2: Boundary Conditions..... 3.3  
 Table 4–1: Estimated Wastewater Peak Flow ..... 4.1  
 Table 5–1: Peak Controlled (Rooftop) 5-Year and 100-Year Release Rate ..... 5.4  
 Table 5–2: Peak Uncontrolled (Non-tributary) 5-Year and 100-Year Release Rates ..... 5.5  
 Table 5–3: Estimated Discharge from Site (5-Year) ..... 5.6  
 Table 5–4: Estimated Discharge from Site (100-Year) ..... 5.6  
 Table 5–5: 100 Year Estimated Discharge for Southern portions of site ..... 5.6  
 Table 9–1: Recommended Pavement Structure ..... 9.4

**LIST OF FIGURES**

Figure 1: Key Plan (1300 & 1310 McWatters Road. Proposed Site Highlighted in Blue) ..... 1.1

**LIST OF APPENDICES**

**APPENDIX A POTABLE WATER SERVICING ..... A.1**  
 A.1 Water Demand Calculations ..... A.1  
 A.2 Fire Flow Requirements per FUS Guidelines..... A.2  
 A.3 Boundary Conditions ..... A.1

**APPENDIX B SITE PLAN ..... B.1**

**APPENDIX C SANITARY SERVICING ..... C.1**  
 C.1 Sanitary Sewer Design Sheet ..... C.1  
 C.2 Correspondence with City on Sanitary Sewer Capacity ..... C.2

**APPENDIX D STORMWATER SERVICING AND MANAGEMENT ..... D.3**  
 D.1 Modified Rational Method Calculations ..... D.3  
 D.2 Modified Rational Method Calculations (Southern Portion) ..... D.4  
 D.3 Correspondence with Rideau Valley Conservation Authority (RVCA) ..... D.5  
 D.4 Oil-Grit Separator Design Sheet ..... D.6  
 D.5 Storm Sewer Design Sheet ..... D.7

**APPENDIX E EXTERNAL REPORTS ..... E.1**  
 E.1 Geotechnical Investigation (Paterson, 2021) ..... E.1

**APPENDIX F DRAWINGS ..... F.1**



# 1.0 INTRODUCTION

Stantec Consulting Ltd. has been commissioned by Homestead Land Holdings Limited to prepare the following site servicing and stormwater management report in support of the site plan control application for the proposed development located at 1300 McWatters Road. The property area is bound by Lisa Avenue to the north, McWatters Road to the east, Baseline Road and commercial businesses to the south, and Greenbank road to the west. The existing property contains an existing 20-storey apartment building, an existing 17-storey apartment building and an existing 1-storey private amenity/recreation building within a 2.56ha property area. The existing private amenity/recreation building will be removed to allow for the proposed development. The key plan is illustrated in **Figure 1**.

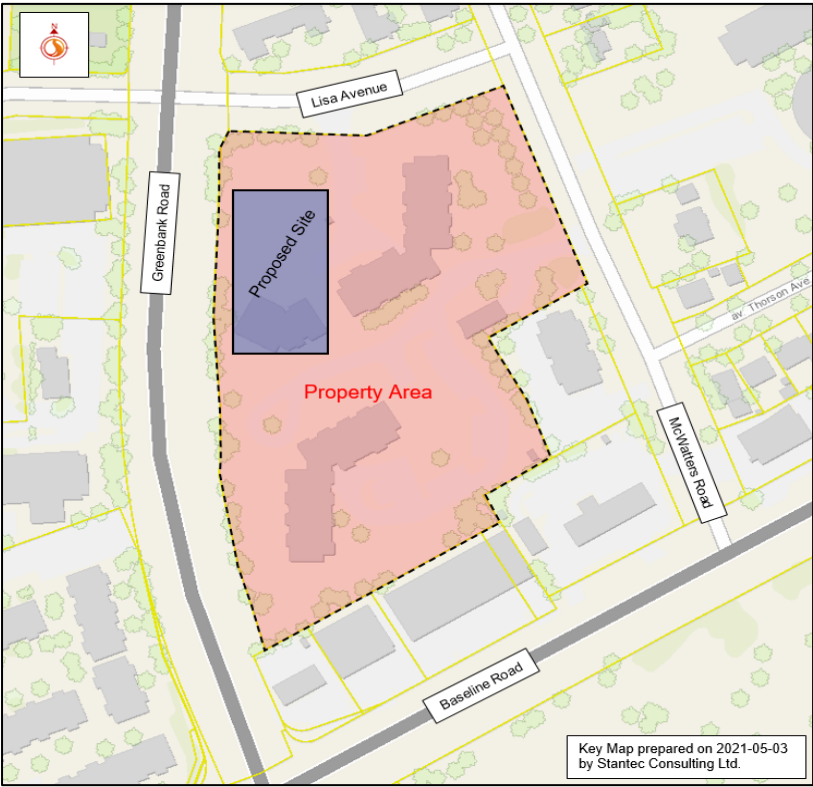

**Figure 1: Key Plan (1300 & 1310 McWatters Road. Proposed Site Highlighted in Blue)**

The proposed development area (0.68 ha) consists of a 25-storey residential high-rise building. The building is to contain a total of 235 units consisting of 71 one-bedroom units, 24 one-bedroom with den units, 138 two-bedroom units, 1 two-bedroom with den units and approximately 3829 m<sup>2</sup> of amenity space. Internal circulation in the proposed development will be provided by access lanes for vehicles, surface parking for 34 vehicles, and two new levels of underground parking for 232 vehicles as well as pedestrian access and landscape open space. The site is currently zoned as “RB5 (H18)” per zoning by-law 2008-250 as shown in **Appendix B**.



# 1300 MCWATTERS ROAD –SERVICING AND STORMWATER MANAGEMENT REPORT

## Introduction

Consultation with the City of Ottawa, Rideau Valley Conservation Authority and engineering studies provided by Homestead provide the relevant background information, criteria and existing conditions data required to support detailed design process.

## 1.1 OBJECTIVE

This servicing report has been prepared to present a servicing scheme that is free of conflicts and presents the most suitable servicing approach that complies with the relevant city design guidelines. Infrastructure requirements for water supply, sanitary sewer, and stormwater management are presented in this report.

Criteria and constraints provided by the City of Ottawa have been used as a basis for the detailed servicing design of the proposed development. Specific elements and potential development constraints to be addressed are as follows:

- **Potable Water Servicing**

- Estimate water demands to characterize the feed for the proposed development which will be serviced by an existing 200 mm diameter watermain fronting the site along Lisa Avenue.
- Watermain servicing for the development is to be able to provide average day, maximum day and peak hour demands (i.e., non-emergency conditions) at pressures within the allowable range of 40 to 80 psi (276 to 552 kPa).
- Under fire flow (emergency) conditions with maximum day demands, the water distribution system is to maintain a minimum pressure greater than 20 psi (140 kPa).

- **Wastewater Servicing**

- Estimate wastewater flows generated by the development and size sanitary sewers which will outlet to the existing 250 mm diameter sanitary sewer located on Lisa Avenue.

- **Stormwater Management and Servicing**

- Determine the stormwater management storage requirements to meet the allowable release rate.
- Post development peak 100-year flows controlled to the predevelopment peak 5-year release rate with a runoff coefficient of  $C=0.5$  and a time of concentration of 10 minutes.
- Excess stormwater to be detained on-site to meet a 5-year pre-development target release rate.
- Define major and minor conveyance systems in conjunction with the detailed grade control plan.

- Prepare a detailed grading plan in accordance with the proposed site plan and existing grades.

The accompanying drawings included in **Appendix F** illustrate the detailed internal servicing scheme for the site.



## References

## 2.0 REFERENCES

Documents referenced in preparation of this Adequacy of Services report for 1300 & 1310 Mcwatters Road include:

- *Adequacy of Services Report*, 1300 & 1310 McWatters Road, Prepared for Homestead Land Holdings Inc Stantec, June 2021.
- *City of Ottawa Design Guidelines - Water Distribution*, City of Ottawa, July 2010 (including all subsequent technical bulletins).
- *City of Ottawa Sewer Design Guidelines (SDG)*, City of Ottawa, October 2012 (including all subsequent technical bulletins).
- *Geotechnical Investigation*, Proposed Multi-storey Building 1300 – 1310 McWatters Road, Ottawa, Ontario, Prepared for Homestead Land Holdings Inc by Paterson Group, May 2021.





## 3.0 POTABLE WATER SERVICING

### 3.1 BACKGROUND

The subject site is located within Pressure Zone 1W of the City of Ottawa's water distribution system. The proposed development will be serviced by the existing 200mm diameter watermain within Lisa Avenue and a new fire hydrant to be installed on the south side of Lisa Avenue. To create a suitable water service connection for the property a new 200 mm line valve will be installed on the existing 200 mm dia. watermain between two 150mm diameter PVC water services to provide potable water and fire flow water supply to the development. The dual water connections will provide supply redundancy to the development per the City of Ottawa Water Distribution Guidelines. Additionally, a new fire hydrant is to be installed on Lisa Avenue as shown on **SSP-1 Drawing** as shown in **Appendix F**. The location of the water services within the property area will be coordinated with the building's architect to accommodate the underground parking structure on Level P1 and P2.

### 3.2 WATER DEMANDS

#### 3.2.1 Domestic Water Demands

Water demands were calculated using the City of Ottawa Water Distribution Guidelines (2010) to determine the typical operating pressures to be expected at the building (see detailed calculations in **Appendix A.1**). A demand rate of 280 L/cap/day was applied for the population of the proposed site per technical bulletin ISTB 2021-03. The average daily (AVDY) residential demand was estimated with population densities as per City of Ottawa Guidelines; density of 1.4 persons per one-bedroom apartments, 2.1 persons per one-bedroom with den two-bedroom apartments and 3.1 per two-bedroom apartments with den.

A demand of 28,000 L/ha/day was applied to the 3829 m<sup>2</sup> communal amenity space. Water demand projections were calculated according to MOE guidelines for a population under 500 people. Given that the number of dwelling units serviced is greater than 167 which is the highest value in Table 3.3 of the Ontario Design Guidelines for Drinking Water Systems but the overall population is less than 500 persons, the following peaking factors were used for conservatism:

Night minimum hour factor: 0.4

Maximum Day Factor: 2.9

Peak Hour Factor: 4.3

The estimated demands are summarized in **Table 3–1** below.



**Table 3–1: Estimated Water Demands**

Demand Type	Population	Area (m <sup>2</sup> )	AVDY (L/s)	Night Minimum Hour (L/s)	MXDY (L/s)	PKHR (L/s)
Residential	443	-	1.43	0.57	4.16	6.17
Amenity Space	-	3829	0.12	0.05	0.36	0.53
<b>Total Site:</b>	443	-	<b>1.56</b>	<b>0.62</b>	<b>4.52</b>	<b>6.70</b>

Values are subject to rounding

### 3.2.2 Fire Flow Demands

Fire flow requirements were estimated using Fire Underwriters Survey (FUS) methodology (2020) and determined to be approximately 6,000 L/min (100.0 L/s). The FUS estimate is based on a building of non-combustible construction with a two-hour fire separation provided between each floor per Ontario Building Code (OBC) requirements for buildings over six storeys, and vertical openings and external vertical communications properly protected (one-hour fire rating). As a result, the 'gross construction area' of the ground floor (floor with the largest footprint, 1435 m<sup>2</sup>) + 25% of the gross construction area of the two immediately adjoining floors (the second floor and third floor) were used for the purpose of the FUS calculation. Additionally, it is anticipated that the building will be sprinklered, with final sprinkler design to conform to the NFPA 13 standard. Detailed fire flow calculations per the FUS methodology are provided in **Appendix A.2**.

### 3.2.3 Boundary Conditions

The boundary conditions provided by the City of Ottawa on June 9<sup>th</sup>, 2021 as shown in **Table 3–2** shows the hydraulic boundary conditions for the site and have been used to determine the residual watermain pressures on Lisa Avenue.

**Table 3–2: Boundary Conditions**

	Connection at Lisa Ave
<b>Min. HGL (m)</b>	106.9
<b>Max. HGL (m)</b>	115.2
<b>Max. Day + Fire Flow (100 L/s) (m)</b>	104.30

Based on the proposed finished floor elevation of 77.10m which will serve as the ground elevation for the calculation of residual pressures at ground level. On-site pressures are expected to range from **42 psi** to **54 psi** under normal operating conditions. These values are within of the normal operating pressure range as defined by City of Ottawa design guidelines (desired 50 to 80 psi and not less than 40 psi). Booster pump internal to the building will be required to provide adequate pressures for upper storeys. This pump is to be designed by the buildings' mechanical engineer.



## 1300 MCWATTERS ROAD –SERVICING AND STORMWATER MANAGEMENT REPORT

### Potable Water Servicing

The boundary conditions provided for the proposed development under maximum day demands and fire flow conditions demonstrate that a maximum flowrate of 100 L/s and a residual pressure of 38.7 psi are available. This value is above the required minimum residual pressure of 20 psi, demonstrating that there is sufficient fire flow and onsite pressure for the proposed development to meet City of Ottawa requirements.

#### 3.2.4 Proposed servicing

The proposed development is proposed to be serviced by the existing 200mm diameter watermain on Lisa Avenue. To create a suitable water service connection for the property a new 200 mm line valve will be installed on the existing 200 mm dia. watermain between two 150mm diameter PVC water services to provide potable water and fire flow water supply to the development. Additionally, a new fire hydrant is to be installed on Lisa Avenue as shown on **SSP-1 Drawing** as shown in **Appendix F**. The location of the water services within the property area will be coordinated with the building's architect to accommodate the underground parking structure on Level P1 and P2.

In summary, the proposed water servicing plan is adequate supply and pressure in the water distribution system to meet the domestic and fire flow demands expected from the new development.



Wastewater Servicing

## 4.0 WASTEWATER SERVICING

Sanitary servicing for the proposed development is proposed to be provided through a single proposed 250 mm sanitary sewer flowing into the existing 250 mm diameter concrete sanitary sewer within Lisa Avenue. The existing sanitary sewers, as well as the proposed sanitary sewer network are expected to be routed on the edge of the proposed parking structure as shown in **Drawing SSP-1 in Appendix F**. The location and layout of the sanitary network within the proposed parking structure will be coordinated with the mechanical and structural engineer and addressed at the detailed design stage.

The proposed 25-storey residential high-rise building is to contain 3829 m<sup>2</sup> of amenity space with a total estimated population of 426 persons using the City of Ottawa’s recommended population densities. The anticipated wastewater peak flow generated from the proposed development is summarized in **Table 4–1** while the sanitary sewer design sheet is included in **Appendix A**.

**Table 4–1: Estimated Wastewater Peak Flow**

Residential/Amenity Peak Flows					Infiltration Flow (L/s)	Total Peak Flow (L/s)
Demand Type	No. of Units/ Area (ha)	Population	Peak Factor	Peak Flow (L/s)		
Residential	234 units	445	3.21	4.61	0.22	5.03
Amenity	0.38	-	1.50	0.19		
Existing Building A						5.03
Existing Building B						5.03
<b>Total Site</b>						<b>15.09</b>

1. Average residential sanitary flow = 280 L/p/day per City of Ottawa Sewer Design Guidelines.
2. Peak factor for residential units calculated using Harmon’s formula. Used a Harmon correction factor of 0.8.
3. Apartment population estimated based on 1.4 persons/unit for one-bedroom apartments, 2.1 persons/unit for two-bedroom apartments.
4. Estimated amenity area/lobby peak flows = 28,000 L/ha/day.
5. Infiltration flow = 0.33 L/s/ha.

The City has confirmed that the 250 mm diameter concrete sanitary sewer on Lisa Avenue has been evaluated by the City and confirmed to have sufficient capacity to accept the peak sanitary flows from the proposed development, please see **Appendix C.2**.

Total Site flows of 15.09L/s will outlet to the existing sanitary sewer on Lisa Avenue via 200mm diameter PVC connection which will replace the existing 200mm diameter asbestos cement sanitary lateral.

A backflow preventer will be required for the proposed building in accordance with the City of Ottawa Sewer Design Guidelines. This requirement will be coordinated with the building’s mechanical engineer.



The drains within the underground parking garage will need to be pumped and ultimately outlet to the proposed sanitary service. The design of these drains, internal plumbing, and associated pumping system is to be completed by the building's mechanical engineer.

## 5.0 STORMWATER MANAGEMENT AND SERVICING

### 5.1 OBJECTIVES

The objective of this stormwater management (SWM) plan is to determine the measures necessary to control the quantity and quality of stormwater released from the proposed development to the required levels, and to provide sufficient detail for approval and construction.

### 5.2 EXISTING CONDITIONS AND SWM CRITERIA

The subject site currently consists of two existing buildings referred to as Building A and B. Each building with dedicated underground parking, surface parking, pedestrian walkways, and green areas. The proposed development area (0.68 ha) currently consists of an existing amenity/recreation building on the western edge of the property, an access lane, a paved parking lot, and green landscaped areas. The existing amenity/recreation structure within the development area will be removed to allow for the proposed residential high-rise building. Refer to existing conditions plan **Drawing EX-1** in **Appendix F** for more details. It is estimated that the proposed redevelopment will increase the overall run-off coefficient (C) of the existing site from 0.52 to 0.61, indicating an eighteen (18) percent increase. As this value exceeds 0.5, a run-off coefficient (C) of 0.5 has been used for all SWM analysis as per City of Ottawa requirements.

The design methodology for the stormwater management (SWM) component of the development has been determined through assessment of criteria provided in preconsultation with the City of Ottawa, Ottawa Sewer Design guidelines and all subsequent bulletins, predevelopment conditions and consultation with RVCA staff. The following summarises the criteria used in the preparation of this stormwater management plan:

- Post-development allowable peak flow up to 100-year event are to be controlled to the pre-development peak 5-year release rate. Excess stormwater is to be detained on-site.
- The 5-yr storm event using the IDF information derived from the Meteorological Services of Canada rainfall data, taken from the MacDonald Cartier Airport, collected 1966 to 1997.
- Calculated predevelopment runoff coefficient of 0.5 or whichever is less.
- A calculated time of concentration (Cannot be less than 10 minutes).
- Foundation drain is to be independently connected to sewer main unless being pumped with appropriate back up power, sufficient sized pump and back flow prevention.
- No surface ponding on private parking areas during the 2-year storm rainfall event.
- Stormwater cistern equipped with a mechanical pump to be provided in underground parking area to meet quantity control criteria.



## Stormwater Management and Servicing

- Quality control measures of 80% TSS removal is to be provided.

### 5.3 STORMWATER MANAGEMENT DESIGN

Stormwater runoff from the development area will be controlled on site and directed to the existing 300 mm diameter storm sewer within Lisa Avenue at a restricted release rate via a 300mm diameter PVC single connection. The proposed storm sewer outlet will be used to discharge groundwater from foundation drainage, controlled roof drainage, and controlled surface drainage collected in an internal building cistern. Based on the finished floor elevation of the underground parking and the elevation of the existing storm sewer on Lisa Avenue, it is anticipated that a sump pump will be required as part of the building internal plumbing system.

The development requires the realignment of the storm collection system for the existing portion of the site. It will be rerouted along the east side of the proposed building with a connection to the connection for the 300mm storm sewer in Lisa Avenue.

Refer to **Appendix D.5** for pipe sizing and **Drawing SSP-1** in **Appendix F** for storm servicing plan.

#### 5.3.1 Design Methodology

The proposed stormwater management plan is designed to detain runoff on rooftops, direct runoff from surface parking areas, green areas, and walkway to storm cistern located at P1 level of underground parking, while the remaining site drains uncontrolled to the R.O.W on Lisa Avenue and Greenbank Road without exceeding the allowable release rate for the development. This ensures that peak flows after construction will not exceed the predevelopment release rate for the site.

As part of the SWM approach, the site was subdivided into Five (5) catchment areas located on the northern end containing Building B and C (i.e. (UNK-1, ROOF-1, ROOF-2, ROOF-3 & AREA-1) as shown in Storm Drainage Plan (**Drawing SD-1**) in **Appendix F**. Due to changes in the roadway and addition of a shed building in the southern portion of the site, the affected areas were also assessed, and storm storage proposed to capture additional attributed to an increase in imperviousness area (refer to **Drawing EX-SD-1** for details).

#### 5.3.2 Allowable Release Rate

The Modified Rational Method (MRM) was employed to determine the allowable release rate for the site. The predevelopment condition runoff coefficient was calculated as  $C=0.52$ , however,  $C=0.50$  would be used to determine the target release from the site based on criteria set by the City of Ottawa in our Preconsultation meeting. A time of concentration ( $t_c$ ) of 10 minutes was adopted for the SWM analysis based on criteria set by City of Ottawa in preconsultation notes.

The pre-development allowable peak stormwater flow rate for the site was calculated as **90.84L/s** using the Modified Rational Method. Post development flows shall be restricted to the established target release rate.



Stormwater Management and Servicing

**5.3.3 Stormwater Quantity Control**

Stormwater storage is expected to be detained on the proposed building’s rooftop not exceeding 150mm depth of storage. A stormwater cistern will also be required to attenuate peak flows from surface parking lot and landscaped areas within the site in order to meet the target release rate in a 100- year event.

**Table 5–1 section 5.3.4.2** below demonstrates the anticipated 100-year release rates.

**5.3.4 Storage Requirements**

To meet the stormwater release criteria, it is proposed that restricted release rooftop drains be used to provide storm detention benefits on rooftops as well as reduce the peak outflow from the site. Additionally, a stormwater cistern located in the underground parking area P1 will be provided to detain run-off to be released at a rate controlled by a mechanical pump. **Drawing SD-1** shows the delineated roof areas and design release rate from the rooftop. Stormwater management calculations are provided in **Appendix D.1**.

**5.3.4.1 Rooftop Storage**

It is proposed to retain stormwater on the rooftops (ROOF-1, ROOF-2, and ROOF-3) by installing restricted flow roof drains.

Watts roof drain data has been used to calculate a practical roof release rate and detention storage volume for the rooftops. It should be noted that the “Watts” roof drain has been used as an example only and that other products may be specified for use, provided that the roof release rate is restricted to match the maximum rate of release indicated in **Table 5–1** and that sufficient roof storage is provided to meet (or exceed) the resulting volume of detained stormwater.

**Table 5–1** provide details regarding the retention of stormwater on the proposed rooftop during the 5 and 100-year storm events. Refer to **Appendix D.1** for details.

**Table 5–1: Peak Controlled (Rooftop) 5-Year and 100-Year Release Rate**

Area ID	Return period	No. of Roof Drains	% Open	Area (ha)	Head (m)	Q <sub>release</sub> (L/s)	V <sub>required</sub> (m <sup>3</sup> )	V <sub>available</sub> (m <sup>3</sup> )
ROOF-1	5 Year	1	50	0.01	0.09	1.4	1.2	5.2
	100 Year				0.12	1.9	2.9	
ROOF-2	5 Year	4	50	0.03	0.08	4.8	1.7	11.7
	100 Year				0.11	6.7	4.7	
ROOF-3	5 Year	4	75	0.11	0.11	4.1	18.2	42
	100 Year				0.15	5.0	41.0	

Stormwater run-off from the rooftops is proposed to be drain directly to the storm sewer via the internal plumbing of the building.



**5.3.4.2 Stormwater Cistern**

A stormwater cistern is proposed to capture run-off from the underground parking ramp (CSTN-1) via the building internal plumbing, parking deck areas (surface parking, green areas, and walkways) via area drains. rooftop storage areas (ROOF-1, ROOF-2, & ROOF-3) will be directed to the storm sewer via the building internal plumbing. An estimated storage volume of 57m<sup>3</sup> is proposed to attenuate peak flows from these areas for release at a controlled flow rate of 42 L/s achieved by a mechanical pump. The details of the mechanical pump and building internal plumbing will be designed by the Mechanical engineer and coordinated with the building’s architect and structural engineer. The proposed stormwater cistern would be sufficient to meet the desired target release rate for the site.

Additional storm run-off attributed to the 14 percent (%) increase in impervious area in the southern portion of the site from C=0.51 to C=0.59 was estimated to require 15m<sup>3</sup> of additional storage to attenuate peak flows without exceeding the target release for the site (Refer to **Appendix D.2** for details). Storage is proposed to be provided through a storm cistern in existing Building A.

**5.3.5 Uncontrolled Area**

A portion of the site fronting Lisa Avenue and Greenbank Road (see area **UNK-1** on **Drawing SD-1**) could not be graded to enter the site’s storm system and as such will sheet drain uncontrolled to the adjoining City R.O.W. Runoff from this uncontrolled area is included in the overall site discharge calculations and is within the allowable release rate for the site. **Table 5–2** summarizes the 5 and 100-year uncontrolled release rates from the proposed development that do not enter the proposed storm sewer system in existing building A.

**Table 5–2: Peak Uncontrolled (Non-tributary) 5-Year and 100-Year Release Rates**

Storm Event	Area (ha)	Runoff ‘C’	Tc (min)	Q <sub>release</sub> (L/s)
5-Year	0.12	0.45	10	15.61
100-Year		0.56		33.45

**5.3.6 Results**

The proposed building will have two level of underground parking and as such, it is proposed that the proposed parking ramp be equipped with a trench drain connected to the internal plumbing of the building to capture the 100-year runoff. Similarly, the proposed parking deck area containing surface parking, walkway and green areas will have catchbasins/drains connected to the internal plumbing of the building to capture the 100-year runoff to the cistern.

It is recommended that the proposed building be equipped with a sump pump and a backwater valve for foundation drainage. **Table 5–3** and

**Table 5–4** demonstrate that the proposed stormwater management plan provides adequate attenuation storage to meet the target peak outflows for the site.





# 1300 MCWATTERS ROAD –SERVICING AND STORMWATER MANAGEMENT REPORT

## Stormwater Management and Servicing

**Table 5–3: Estimated Discharge from Site (5-Year)**

Building Area	Area Type	Area ID	V <sub>required</sub> (m <sup>3</sup> )	V <sub>available</sub> (m <sup>3</sup> )	Q <sub>release</sub> (L/s)	Target (L/s)
BUILDING B & C	Storm cistern	CSTN-1, AREA-1	12	57	42	<b>91</b>
	Roof	ROOF-1, ROOF-2, ROOF-3	21	59	10	
	Uncontrolled Areas	UNK-1	-	-	16	
	<b>Total</b>			<b>33</b>	<b>116</b>	

**Table 5–4: Estimated Discharge from Site (100-Year)**

Building Area	Area Type	Area ID	V <sub>required</sub> (m <sup>3</sup> )	V <sub>available</sub> (m <sup>3</sup> )	Q <sub>release</sub> (L/s)	Target (L/s)
BUILDING B & C	Storm cistern	CSTN-1, AREA-1	56.5	57	59	<b>91</b>
	Roof	ROOF-1, ROOF-2, ROOF-3	49	59	13.6	
	Uncontrolled Areas	UNK-1	-	-	33.5	
	<b>Total</b>			<b>105</b>	<b>116</b>	

As can be seen in the above tables, the proposed storm cistern fitted with a mechanical pump and uncontrolled area meet the target release rate for the 5 and 100- year events.

15m<sup>3</sup> storage is proposed within the underground parking area of Building A to capture excess storm run-off from the southern portion attributed to the 14% change in imperviousness within this area as shown in **Table 5–5** and **Appendix D.2**. The proposed additional flow will be restricted by a mechanical pump to a flow rate not exceeding the 100-year release rate under existing site conditions estimated as 168L/s.

**Table 5–5: 100 Year Estimated Discharge for Southern portions of site**

Building Area	Predevelopment ID	Area ID	Area (ha)	C	100Yr Q <sub>release</sub> (L/s)	Target (L/s)	V <sub>required</sub> (m <sup>3</sup> )	V <sub>available</sub> (m <sup>3</sup> )
BUILDING A	Pre-development	EX-2, EX-3	<b>0.66</b>	0.51	168	<b>168</b>	-	-
	Post-development	POST-1, POST-2		0.59	192		<b>14</b>	<b>15</b>



#### 5.3.7 Stormwater Quality Control

The RVCA confirmed that enhanced water quality protection (80% TSS removal) is required for the site based on the number of surface parking spaces correspondence with the RVCA is included in **Appendix D.3**. To achieve this end, storm runoff within the access road area of the site will be captured into the site storm sewer system and directed to the proposed oil/grit separator unit.

The Stormceptor sizing software has been used to size the required unit to provide up to 89% TSS removal as shown in the Stormceptor sizing design sheet and standard detail included in **Appendix D.4**.

A Stormceptor EF 06 or an approved equivalent designed to provide up to > 80% TSS removal has been proposed to collect and treat storm runoff from the site before discharging into the existing 200mm diameter storm sewer on Lisa Avenue as shown in **Drawing SSP-1** in **Appendix F**.



## 6.0 GRADING AND DRAINAGE

The proposed re-development site measures approximately 0.68 ha in area. The existing topography across the site is relatively flat, and currently drains from south to north, with overland flow generally being directed to the adjacent Lisa Avenue ROW. A detailed grading plan (see **Drawing GP-1**) has been prepared to satisfy the City requirement to match post-development site grading to existing property line grades in order to minimize disruption to the adjacent residential properties. The proposed site grading is designed to maintain positive drainage away from the face of the building and adhere to geotechnical recommendations for the site. Site grading has been established to provide emergency overland flow routes required for stormwater management in accordance with City of Ottawa requirements. No grade raise restrictions have been identified for this site by the geotechnical consultant. The geotechnical investigation recommends the existing foundation walls and other construction debris should be entirely removed from within the proposed building perimeter and within the lateral support zones of the foundations. Under paved areas, existing construction remnants, such as foundation walls, should be excavated to a minimum of 1 m below final grade.

The subject site is graded to provide an emergency overland flow route to Lisa Avenue for storm flows exceeding those generated by the 100-year design storm.

## 7.0 UTILITIES

Hydro Ottawa, Bell, Rogers, and Enbridge all have existing utility plants in the area, which will be used to service the site. The detailed design of the required utility services will be further investigated as part of the composite utility planning process, which will follow design circulation for the servicing plans. The relocation of existing utilities in conflict with the proposed development will be coordinated with the individual utility providers as part of the site plan approval process by the civil engineer.

Relocation of existing utilities affected by the proposed development will be coordinated with the affected utility company.



## 8.0 EROSION CONTROL DURING CONSTRUCTION

In order to protect downstream water quality and prevent sediment build up in catch basins and storm sewers, erosion and sediment control measures must be implemented during construction. The following recommendations will be included in the contract documents and communicated to the Contractor.

1. Implement best management practices to provide appropriate protection of the existing and proposed drainage system and the receiving water course(s).
2. Limit the extent of the exposed soils at any given time.
3. Re-vegetate exposed areas as soon as possible.
4. Minimize the area to be cleared and grubbed.
5. Protect exposed slopes with geotextiles, geogrid, or synthetic mulches.
6. Provide sediment traps and basins during dewatering works.
7. Install sediment traps (such as SiltSack® by Terrafix) between catch basins and frames.
8. Schedule the construction works at times which avoid flooding due to seasonal rains.

The Contractor will also be required to complete inspections and guarantee the proper performance of their erosion and sediment control measures at least after every rainfall. The inspections are to include:

- Verification that water is not flowing under silt barriers.
- Cleaning and changing the sediment traps placed on catch basins.



## 9.0 GEOTECHNICAL INVESTIGATION

Paterson Group (Paterson) was commissioned by Homestead Land Holdings Ltd. to conduct a geotechnical investigation for the proposed multi-storey building to be located at 1300-1310 McWatters Road, in the City of Ottawa, Ontario.

The field program for the geotechnical investigation was carried out from April 29 to May 3, 2021, and consisted of advancing 5 boreholes to a maximum depth of 22.6 m. The borehole locations were determined in the field by Paterson personnel taking into consideration site features and underground services.

Monitoring wells were installed in boreholes BH 2-21 through BH 4-21 to permit monitoring of the groundwater levels subsequent to the completion of the sampling program. Flexible standpipes were also installed in boreholes BH 1-21 and BH 5-21. All monitoring wells should be decommissioned in accordance with Ontario Regulations O.Reg 903 by a qualified licensed well technician and prior to construction.

As described in the report by Paterson, the subsurface profile at the test hole locations consists of a 50 to 130 mm thick asphalt layer underlain by a 4.4 to 5.7 m thick fill layer. The fill material was generally observed to vary from a brown silty sand with trace gravel, to a brown to grey silty clay layer with sand and gravel, to topsoil with organics and wood with depth. The fill was observed to be underlain by a deposit of compact to dense, brown to grey silty sand which was further underlain by bedrock.

The bedrock was observed to consist of grey, interbedded quartz sandstone and limestone, and based on the RQDs of the recovered bedrock core, was generally of good to excellent in quality. At boreholes BH 4-21 and BH 5-21, The bedrock was cored to depths of from 22.6 to 21.1 m below the existing ground surface, respectively (refer to **Appendix E.1** for more details in the full report.).

Groundwater level readings were measured in the monitoring wells installed at boreholes BH 2-21 to BH 4-21 as well as the peizometers installed at boreholes BH 1-21 and BH 5-21 on May 12, 2021. Based on these observations, the long-term groundwater level is anticipated at a depth of approximately 7 to 9 m below ground surface. However, groundwater levels are subject to seasonal fluctuations and could vary at the time of construction.

Based on the recommendation by Paterson, the subject site is suitable for the proposed development. It is recommended that the proposed multi-storey building be founded on one of the following:

- Conventional spread footings bearing on an undisturbed, compact to dense silty sand bearing surface.
- A raft foundation bearing on an undisturbed, compact to dense silty sand bearing surface.

Where the footings of the proposed building abut the neighboring existing building, they should match the existing footing elevations.



## Geotechnical Investigation

The recommended rigid pavement structure is further presented in **Table 9–1** below.

**Table 9–1: Recommended Pavement Structure**

<b>Material</b>	<b>Rigid pavement structure Lower Parking Level</b>	<b>Asphalt Pavement Structure - Access Lanes and Heavy Loading Parking Areas</b>
Exposure Class C2 - 32 MPa Concrete (5 to 8% Air Entrainment)	150 mm	-
Superpave 12.5 Asphaltic Concrete – Wear Course	-	40 mm
SP 19 Asphaltic Concrete – Binder Course	-	50 mm
Granular Base Course, OPSS Granular A	300 mm	150 mm
Granular Subbase Course, OPSS Granular B Type II	-	300 mm

Refer to the full geotechnical report attached in **Appendix E.1** for further details.



## 10.0 APPROVALS/PERMITS

Ontario Ministry of Environment, Conservation and Parks (MECP) Environmental Compliance Approval under the Ontario Water Resources Act is not anticipated to be required for proposed storm and sanitary sewers for the proposed site.

An MECP Permit to Take Water (PTTW) may be required for the site as some of the proposed works may be below the groundwater elevation shown in the geotechnical report. The geotechnical consultant shall determine whether a PTTW is required at the detailed design stage/ prior to construction. No other approval has been identified to be required at this point.



## 11.0 CONCLUSIONS

### 11.1 POTABLE WATER SERVICING

Based on the potable water servicing analysis the proposed network can service the subject site and meets all servicing requirements as per City of Ottawa standards under typical demand conditions (peak hour and minimum hour conditions) as well as under emergency fire demand conditions (maximum day + fire flow). The proposed site will provide the required potable water and fire flow with two 150mm diameter water services connecting to the existing 200mm diameter watermain on Lisa Avenue. The results demonstrate there is currently sufficient supply and pressure in the water distribution system to meet the demands expected from the new development.

### 11.2 WASTEWATER SERVICING

The City has confirmed that the 250 mm diameter concrete sanitary sewer on Lisa Avenue has sufficient capacity to accept the peak sanitary flows from the proposed development. The proposed sanitary sewer connection will be rerouted around the underground parking garage.

### 11.3 STORMWATER MANAGEMENT AND SERVICING

The proposed stormwater management plan is in compliance with local and provincial standards. Rooftop storage with controlled roof drains, and subsurface storage via a cistern located in the underground parking area has been proposed to limit peak storm sewer inflows to the existing 300mm diameter storm sewers along Lisa Avenue ROW. A Stormceptor unit (or equivalent) located upstream of storm service connection to existing sewer on Lisa Avenue is proposed to meet the quality control criteria for the site.

### 11.4 GRADING

Grading for the site has been designed to provide an emergency overland flow route as per City requirements and reflects recommendations in the Geotechnical Investigation Report prepared by Paterson Group Inc. in May 2021. Erosion and sediment control measures will be implemented during construction to reduce the impact on existing facilities.

### 11.5 UTILITIES

Hydro Ottawa, Bell, Rogers, and Enbridge all have existing utility plants in the area, which will be used to service the site. The exact size, location, and routing of utilities will be finalized after design circulation. Existing overhead wires and utility plants may need to be moved/reconfigured to allow sufficient clearance to the proposed building. The relocation of existing utilities will be coordinated with the individual utility providers as part of the site plan approval process by the civil engineer.





Conclusions

## **11.6 APPROVALS/PERMITS**

An MECP Environmental Compliance Approval is not expected to be required for the subject site. A Permit to Take Water will be confirmed by geotechnical consultant. The Rideau Valley Conservation Authority will need to be consulted in order to obtain municipal approval for site development. No other approval requirements from other regulatory agencies are anticipated.



# APPENDICES

## Appendix A POTABLE WATER SERVICING

### A.1 WATER DEMAND CALCULATIONS



**1300 McWatters Road - Domestic Water Demand Estimates**

Site Plan provided by RLA Architecture (2021-12-08)

Project No. 160401668



Densities as per City Guidelines:		
Apartment Units		
1 Bedroom	1.4	ppu
1 Bedroom + Den	2.1	ppu
2 Bedroom	2.1	ppu
2 Bedroom + Den	3.1	ppu

Building ID	Amenity space (m <sup>2</sup> )	No. of Units	Population	Daily Rate of Demand <sup>1 2</sup> (L/cap/day or L/ha/day)	Avg Day Demand		Night Minimum Hour <sup>2</sup>		Max Day Demand <sup>3 4</sup>		Peak Hour Demand <sup>3 4</sup>	
					(L/min)	(L/s)			(L/min)	(L/s)	(L/min)	(L/s)
<b>Apartment Units</b>												
1 Bedroom		71	99	280	19.3	0.32	7.73	0.13	56.1	0.93	83.1	1.39
1 Bedroom + Den		24	50	280	9.8	0.16	3.92	0.07	28.4	0.47	42.1	0.70
2 Bedroom		138	290	280	56.4	0.94	22.54	0.38	163.4	2.72	242.3	4.04
2 Bedroom + Den		1	3	280	0.6	0.01	0.24	0.00	1.7	0.03	2.6	0.04
<b>Amenity Space</b>												
	3829			28000	7.4	0.12	2.98	0.05	21.6	0.36	32.0	0.53
<b>Total Site :</b>		<b>234</b>	<b>443</b>		<b>93.5</b>	<b>1.56</b>	<b>37.41</b>	<b>0.62</b>	<b>271.2</b>	<b>4.52</b>	<b>402.2</b>	<b>6.70</b>

1 Average day water demand for residential areas: 280L/cap/day per ISTB 2021-03

2 The MOE water demand criteria used to estimate peak demand rates for residential areas < 500 equivalent population, over 167 dwelling units serviced are as follows:

Night Minimum Hour Factor = 0.4 x average day demand rate

Maximum day demand rate = 2.9 x average day demand rate

Peak hour demand rate = 4.3 x average day demand rate

## **A.2 FIRE FLOW REQUIREMENTS PER FUS GUIDELINES**





**FUS Fire Flow Calculation Sheet (2020)**

Stantec Project #: 160401668  
 Project Name: 1300 McWatters Road  
 Date: 7/19/2022

Fire Flow Calculation #: 1  
 Description: Residential

24-storey residential high-rise with amenity space on ground floor. Information taken from Draft Site Plan by Roderick Lahey Architect Inc. dated December 12, 2022. 2-hour fire separation provided between each floor and 1-hour fire separation provided for exterior vertical communications.

Step	Task	Notes	Value Used	Req'd Fire Flow (L/min)						
1	Determine Type of Construction	Type III - Ordinary Construction / Type IV-C - Mass Timber Construction	1	-						
2	Determine Effective Floor Area	Sum of Largest Floor + 25% of Two Additional Floors	YES	-						
		2153    0    0    0    0    0    0	2153	-						
3	Determine Required Fire Flow	( $F = 220 \times C \times A^{1/2}$ ). Round to nearest 1000 L/min	-	10000						
4	Determine Occupancy Charge	Limited Combustible	-15%	8500						
5	Determine Sprinkler Reduction	Conforms to NFPA 13	-30%	-4250						
		Standard Water Supply	-10%							
		Fully Supervised	-10%							
		% Coverage of Sprinkler System	100%							
6	Determine Increase for Exposures (Max. 75%)	Direction	Exposure Distance (m)	Exposed Length (m)	Exposed Height (Stories)	Length-Height Factor (m x stories)	Construction of Adjacent Wall	Firewall / Sprinklered ?	-	-
		North	> 30	37	2	61-80	Type V	NO	0%	1275
		East	10.1 to 20	18	20	> 100	Type V	NO	15%	
		South	> 30	43	17	> 100	Type V	NO	0%	
		West	> 30	37	3	> 100	Type V	NO	0%	
7	Determine Final Required Fire Flow	Total Required Fire Flow in L/min, Rounded to Nearest 1000L/min			6000					
		Total Required Fire Flow in L/s			100.0					
		Required Duration of Fire Flow (hrs)			2.00					
		Required Volume of Fire Flow (m <sup>3</sup> )			720					

### A.3 BOUNDARY CONDITIONS



**From:** [Nwanise, Nwanise](#)  
**To:** [Armstrong, Justin](#)  
**Cc:** [Gillis, Sheridan](#); [Rathnasooriya, Thakshika \(Thakshika.Rathnasooriya@stantec.com\)](#)  
**Subject:** RE: 1300 & 1310 McWatters Road - Boundary Conditions Request  
**Date:** Wednesday, June 9, 2021 8:42:00 AM  
**Attachments:** [image001.jpg](#)

---

Hi Justin,

We appreciate your feedback.

Take care and have a nice day.

Regards,

**Nwanise Nwanise**,EIT  
Engineering intern, Community Development

Direct: (647) 400-1759  
Mobile: (647) 400-1759  
[nwanise.nwanise@stantec.com](mailto:nwanise.nwanise@stantec.com)

Stantec  
400 - 1331 Clyde Avenue  
Ottawa ON K2C 3G4



**Better Together, Even If We're Apart.** [Read more](#) about Stantec's COVID-19 response, including remote working and business continuity measures.

The content of this email is the confidential property of Stantec and should not be copied, modified, retransmitted, or used for any purpose except with Stantec's written authorization. If you are not the intended recipient, please delete all copies and notify us immediately.

---

**From:** Armstrong, Justin <[justin.armstrong@ottawa.ca](mailto:justin.armstrong@ottawa.ca)>  
**Sent:** Wednesday, June 9, 2021 8:39 AM  
**To:** Nwanise, Nwanise <[Nwanise.Nwanise@stantec.com](mailto:Nwanise.Nwanise@stantec.com)>  
**Subject:** RE: 1300 & 1310 McWatters Road - Boundary Conditions Request

Good morning Nwanise,

Boundary condition results are below and location map attached.

The following are boundary conditions, HGL, for hydraulic analysis at 1300 & 1310 McWatters (zone 1W) assumed to be connected to the 203mm on Lisa Avenue (see attached PDF for location).

Minimum HGL = 106.9m

Maximum HGL = 115.2m

Max Day + Fire Flow (100 L/s) = 104.3m



These are for current conditions and are based on computer model simulation.

*Disclaimer: The boundary condition information is based on current operation of the city water distribution system. The computer model simulation is based on the best information available at the time. The operation of the water distribution system can change on a regular basis, resulting in a variation in boundary conditions. The physical properties of watermains deteriorate over time, as such must be assumed in the absence of actual field test data. The variation in physical watermain properties can therefore alter the results of the computer model simulation.*

Have a great day,

Justin

---

**From:** Nwanise, Nwanise <[Nwanise.Nwanise@stantec.com](mailto:Nwanise.Nwanise@stantec.com)>  
**Sent:** June 3, 2021 2:29 PM  
**To:** Armstrong, Justin <[justin.armstrong@ottawa.ca](mailto:justin.armstrong@ottawa.ca)>  
**Subject:** RE: 1300 & 1310 McWatters Road - Boundary Conditions Request

Thanks Justin,

Hope to hear back soon.

Regards,

**Nwanise Nwanise**,EIT  
Engineering intern, Community Development

Direct: (647) 400-1759  
Mobile: (647) 400-1759  
[nwanise.nwanise@stantec.com](mailto:nwanise.nwanise@stantec.com)

Stantec  
400 - 1331 Clyde Avenue  
Ottawa ON K2C 3G4



**Better Together, Even If We're Apart.** [Read more](#) about Stantec's COVID-19 response, including remote working and business continuity measures.

The content of this email is the confidential property of Stantec and should not be copied, modified, retransmitted, or used for any purpose except with Stantec's written authorization. If you are not the intended recipient, please delete all copies and notify us immediately.

---

**From:** Armstrong, Justin <[justin.armstrong@ottawa.ca](mailto:justin.armstrong@ottawa.ca)>  
**Sent:** Thursday, June 3, 2021 2:27 PM  
**To:** Nwanise, Nwanise <[Nwanise.Nwanise@stantec.com](mailto:Nwanise.Nwanise@stantec.com)>  
**Subject:** RE: 1300 & 1310 McWatters Road - Boundary Conditions Request

Thanks, Nwanise.

I have sent off the request for boundary conditions and will forward you the results once I receive them.

Justin

---

**From:** Nwanise, Nwanise <[Nwanise.Nwanise@stantec.com](mailto:Nwanise.Nwanise@stantec.com)>

**Sent:** June 3, 2021 9:21 AM

**To:** Armstrong, Justin <[justin.armstrong@ottawa.ca](mailto:justin.armstrong@ottawa.ca)>

**Cc:** Gillis, Sheridan <[Sheridan.Gillis@stantec.com](mailto:Sheridan.Gillis@stantec.com)>; Mott, Peter <[Peter.Mott@stantec.com](mailto:Peter.Mott@stantec.com)>

**Subject:** RE: 1300 & 1310 McWatters Road - Boundary Conditions Request

Good morning Justin,

Hope you are keeping well.

We would like to request a revised hydraulic boundary conditions for the proposed development on 1300 & 1310 McWatters Road.

The demand for the site is as follows:

Type of Development: 25-storey residential high-rise building containing 235 units of 97 one-bedroom units, 138 two-bedroom units, and approx. 1556 m2 of communal amenity space.  
Location of water service: Two 150mm diameter water connections to the existing 200mm DI watermain on Lisa Avenue.  
Average Day Demand: 1.76 L/s  
Maximum Day Demand: 4.37 L/s  
Peak Hourly: 9.58 L/s  
Fire Flow: 100 L/s (6,000L/min) (based on the FUS method), an additional fire hydrant is proposed the site.

Enclosed is a location map and water demand calculation sheets for your information.

Thanks for looking into this us, please do not hesitate to contact me if you need anything.

Regards,

**Nwanise Nwanise**, EIT

Engineering intern, Community Development

Mobile: (647) 400-1759

[nwanise.nwanise@stantec.com](mailto:nwanise.nwanise@stantec.com)

Stantec

400 - 1331 Clyde Avenue

Ottawa ON K2C 3G4



**Better Together, Even If We're Apart.** [Read more](#) about Stantec's COVID-19 response, including remote working and business continuity measures.

---

**From:** Armstrong, Justin <[justin.armstrong@ottawa.ca](mailto:justin.armstrong@ottawa.ca)>  
**Sent:** Thursday, May 6, 2021 1:18 PM  
**To:** Mott, Peter <[Peter.Mott@stantec.com](mailto:Peter.Mott@stantec.com)>  
**Subject:** RE: 1300 & 1310 McWatters Road - Boundary Conditions Request

Hi Peter,

Boundary conditions are below and assessment location map attached.

FYI – Our Senior Water Resources Engineer indicated with the boundary conditions that the fire demand seems a little light for this development.

The following are boundary conditions, HGL, for hydraulic analysis at 1300 & 1310 McWatters (zone 1W) assumed to be connected to the 203mm on Lisa Avenue (see attached PDF for location).

Minimum HGL = 106.9m

Maximum HGL = 115.2m

Max Day + Fire Flow (83 L/s) = 105.7m

These are for current conditions and are based on computer model simulation.

*Disclaimer: The boundary condition information is based on current operation of the city water distribution system. The computer model simulation is based on the best information available at the time. The operation of the water distribution system can change on a regular basis, resulting in a variation in boundary conditions. The physical properties of watermains deteriorate over time, as such must be assumed in the absence of actual field test data. The variation in physical watermain properties can therefore alter the results of the computer model simulation.*

Regards,

**Justin Armstrong, E.I.T.**

Project Manager

Planning, Infrastructure and Economic Development Department - Services de la planification, de l'infrastructure et du développement économique

Development Review - West Branch

City of Ottawa | Ville d'Ottawa

110 Laurier Avenue West Ottawa, ON | 110, avenue. Laurier Ouest. Ottawa (Ontario) K1P 1J1

613.580.2424 ext./poste 21746, [justin.armstrong@ottawa.ca](mailto:justin.armstrong@ottawa.ca)

---

**From:** Mott, Peter <[Peter.Mott@stantec.com](mailto:Peter.Mott@stantec.com)>  
**Sent:** May 6, 2021 12:29 PM  
**To:** Armstrong, Justin <[justin.armstrong@ottawa.ca](mailto:justin.armstrong@ottawa.ca)>  
**Subject:** FW: 1300 & 1310 McWatters Road - Boundary Conditions Request

Hello Justin,

As Ahmed will be out of the office until June 3<sup>rd</sup>, I was hoping you could investigate the status of the below boundary conditions request for me. As specified to Ahmed, I was hoping we could get this information as soon as it is available as we are anticipating a submission for some time next week.

Best,

**Peter Mott** EIT  
Engineering Intern, Community Development

Mobile: 613-897-0445  
[Peter.Mott@stantec.com](mailto:Peter.Mott@stantec.com)  
Stantec  
400 - 1331 Clyde Avenue  
Ottawa ON K2C 3G4



The content of this email is the confidential property of Stantec and should not be copied, modified, retransmitted, or used for any purpose except with Stantec's written authorization. If you are not the intended recipient, please delete all copies and notify us immediately.

---

**From:** Elsayed, Ahmed <[ahmed.elsayed@ottawa.ca](mailto:ahmed.elsayed@ottawa.ca)>  
**Sent:** Tuesday, April 27, 2021 3:50 PM  
**To:** Mott, Peter <[Peter.Mott@stantec.com](mailto:Peter.Mott@stantec.com)>  
**Cc:** Gillis, Sheridan <[Sheridan.Gillis@stantec.com](mailto:Sheridan.Gillis@stantec.com)>  
**Subject:** RE: 1300 & 1310 McWatters Road - Boundary Conditions Request

Hi Peter,

Request has be forwarded to IPU.

Thanks,  
Ahmed

---

**From:** Mott, Peter <[Peter.Mott@stantec.com](mailto:Peter.Mott@stantec.com)>  
**Sent:** Tuesday, April 27, 2021 1:29 PM  
**To:** Elsayed, Ahmed <[ahmed.elsayed@ottawa.ca](mailto:ahmed.elsayed@ottawa.ca)>  
**Cc:** Gillis, Sheridan <[Sheridan.Gillis@stantec.com](mailto:Sheridan.Gillis@stantec.com)>  
**Subject:** 1300 & 1310 McWatters Road - Boundary Conditions Request

**CAUTION: This email originated from an External Sender. Please do not click links or open attachments unless you recognize the source.**

**ATTENTION : Ce courriel provient d'un expéditeur externe. Ne cliquez sur aucun lien et n'ouvrez pas de pièce jointe, excepté si vous connaissez l'expéditeur.**

I would like to request the hydraulic boundary conditions for the proposed site located at 1300 & 1310 McWatters Road. Please find attached the site plan, the key map showing the location of the proposed development, domestic water demand calculations, and fire flow calculations.

A summary of the proposed site is provided below:

We anticipate a connection to the existing watermain infrastructure to service the site. The following connection is expected for servicing:

➤ Two (2) connections to existing 203 mm (DI) watermain on Lisa Avenue.

\*Existing fire hydrant adjacent to the property to the north and east along Lisa Avenue and McWatters Road, respectively.

**For the purpose of the boundary conditions request, may you please provide us with the boundary conditions for the following servicing option:**

i. Two (2) watermain connections to the existing 203 mm (DI) watermain on Lisa Avenue; assuming a fire flow requirement of **5,000 L/min** for the site in addition to the domestic water demands provided below.

- The intended land use is residential, per the summary provided in the Domestic Demands spreadsheet. (See attached Site Plan with project stats)
- Estimated fire flow demand per the FUS methodology: 5000 L/min (83 L/s)
- Domestic water demands for the entire development:
  - **Average day: 103.3 L/min (1.7 L/s)**
  - **Maximum day: 256.6 L/min (4.3 L/s)**
  - **Peak hour: 563.7 L/min (9.4 L/s)**

Thank you for your time and please contact me at your earliest convenience if any additional information or clarification is required.

Best regards,

**Peter Mott** EIT

Engineering Intern, Community Development

Mobile: 613-897-0445

[Peter.Mott@stantec.com](mailto:Peter.Mott@stantec.com)

Stantec

400 - 1331 Clyde Avenue

Ottawa ON K2C 3G4



The content of this email is the confidential property of Stantec and should not be copied, modified, retransmitted, or used for any purpose except with Stantec's written authorization. If you are not the intended recipient, please delete all copies and notify us immediately.

This e-mail originates from the City of Ottawa e-mail system. Any distribution, use or copying of this e-mail or the information it contains by other than the intended recipient(s) is unauthorized. Thank you.

Le présent courriel a été expédié par le système de courriels de la Ville d'Ottawa. Toute distribution, utilisation ou reproduction du courriel ou des renseignements qui s'y trouvent par une personne autre que son destinataire prévu est interdite. Je vous remercie de votre collaboration.

This e-mail originates from the City of Ottawa e-mail system. Any distribution, use or copying of this e-mail or the information it contains by other than the intended recipient(s) is unauthorized. Thank you.

Le présent courriel a été expédié par le système de courriels de la Ville d'Ottawa. Toute distribution, utilisation ou reproduction du courriel ou des renseignements qui s'y trouvent par une personne autre que son destinataire prévu est interdite. Je vous remercie de votre collaboration.

This e-mail originates from the City of Ottawa e-mail system. Any distribution, use or copying of this e-mail or the information it contains by other than the intended recipient(s) is unauthorized. Thank you.

Le présent courriel a été expédié par le système de courriels de la Ville d'Ottawa. Toute distribution, utilisation ou reproduction du courriel ou des renseignements qui s'y trouvent par une personne autre que son destinataire prévu est interdite. Je vous remercie de votre collaboration.

This e-mail originates from the City of Ottawa e-mail system. Any distribution, use or copying of this e-mail or the information it contains by other than the intended recipient(s) is unauthorized. Thank you.

Le présent courriel a été expédié par le système de courriels de la Ville d'Ottawa. Toute distribution, utilisation ou reproduction du courriel ou des renseignements qui s'y trouvent par

une personne autre que son destinataire prévu est interdite. Je vous remercie de votre collaboration.

,

**Appendix B SITE PLAN**





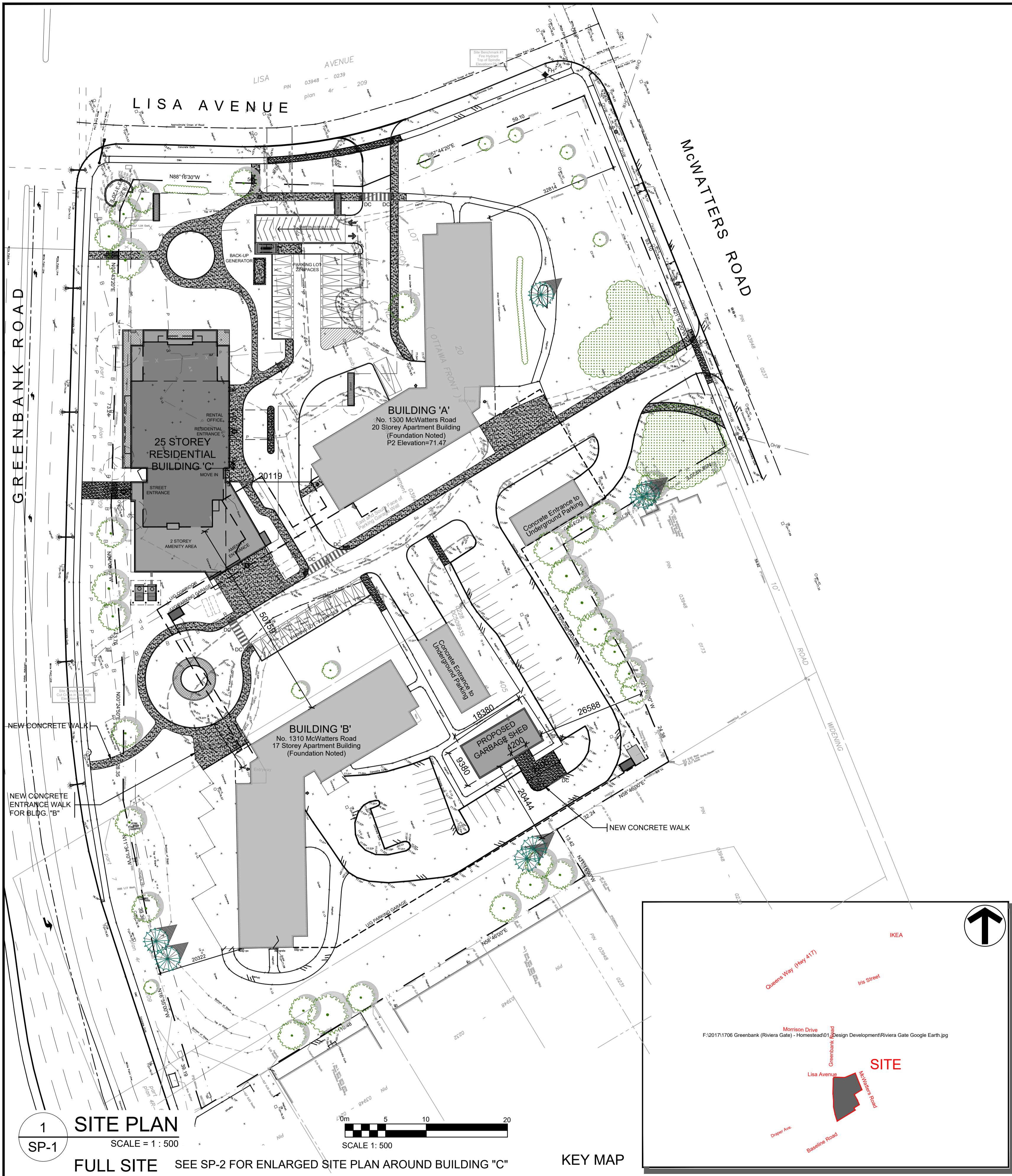

**SITE PLAN SYMBOLS:**

- TERRACE/LANDSCAPE PLANTING
- ASPHALT DRIVE/LEISURE/PARKING
- CONCRETE SIDEWALK
- CONCRETE PAVERS, SEE LANDSCAPE DRAWINGS
- PAVERS @ TERRACE LEVEL
- PROPERTY LINE
- BUILDING SETBACK LINE
- FENCE LINE
- BIKE RACK
- ENTRANCE / EXIT DOOR
- COMMERCIAL / EXIT DOOR
- FIRE HYDRANT
- VEHICULAR DIRECTION
- EXISTING TREE TO REMAIN
- SIAMSE CONNECTION
- PROPOSED GRADE - SEE CIVIL DRAWINGS
- ROOF DRAIN

NOTE: SEE LANDSCAPE FOR ALL SURFACE MATERIAL AND PATTERN

**GEOTECHNICAL ENGINEER**  
**Paterson Group**  
 154 Colonnade Road South  
 Ottawa, Ontario, K2E 7J5  
 Tel.: (613) 226-7381  
 E-Mail: DGilbert@Patersongroup.ca  
 E-Mail: mdarcy@Patersongroup.ca

**WIND / SOUND ENGINEER**  
**Gradient Wind**  
 127 Walgreen Road,  
 Ottawa, ON, Canada K0A 1L0  
 Tel.: (613) 836-0934 ext. 116  
 Cell: (613) 266-5273  
 E-Mail: joshua.foster@gradientwind.com

**ARBORIST**  
**IFS Associates**  
 BOX 13593,  
 Kanata, Ontario K2K 1X6  
 Tel: (613) 838-5717  
 E-Mail: aboyd@ifsassociates.ca

**LANDSCAPE ARCHITECT**  
**Wentworth Landscapes**  
 13392 Loyalist Pkwy.,  
 Picton, Ontario K0K 2T0  
 Tel: (613) 476-1181  
 E-Mail: scott@wentworthlandscapes.com  
 E-Mail: danielle@wentworthlandscapes.com

**TRANSPORTATION ENGINEER**  
**GHD Group Pty Ltd.**  
 179 Colonnade Road South, Suite 400  
 Ottawa ON K2E7J4  
 Phone: (613) 288-1727  
 Direct: (613) 222-6801  
 E-Mail: vanessa.skelton@ghd.com

**SURVEYOR**  
**Annis O'Sullivan Vollebek Ltd.**  
 14 Concourse Gate, Suite 500,  
 Nepean, Ontario K2E 7S6  
 Tel: (613) 727-0850  
 Fax: (613) 727-1079  
 E-Mail: BobV@aovltd.com

**CIVIL ENGINEER**  
**Stantec Geomatics Ltd.**  
 1331 Clyde Avenue, Suite 400  
 Ottawa ON K2C 3G4  
 Phone: (613) 724-4096  
 Fax: (613) 722-2799  
 E-Mail: Sheridan.Gillis@stantec.com

**PROJECT INFORMATION**

ZONING BY-LAW 2008-250 R85 (H18)

**SITE AREA**  
 25,686.0 sq. m.  
 276,482 sq. ft.

**REQUIRED**

GRADE (GEODETIC ELEVATION)	76.90m
BUILDING HEIGHT	18.0m
FRONT YARD SETBACK	3.0m
CORNER YARD SETBACK	3.0m
REAR YARD SETBACK	3.0m
RESIDENTIAL PARKING PER UNIT (AFTER 12 UNITS)	0.5
VISITOR PARKING PER UNIT (AFTER 12 UNITS)	0.2
BICYCLE PARKING PER UNIT	0.5
AMENITY AREA - PER UNIT	6.0 sq. m.
MINIMUM DRIVEWAY WIDTH - EXTERIOR	6.7m
MINIMUM DRIVEWAY / AISLE WIDTH - INTERIOR	6.0m
LANDSCAPE AREA	30%

**PROVIDED**

12 STOREY BUILDING HEIGHT	79.0m
AMENITY / MECHANICAL PENTHOUSE HEIGHT	4.5m
FRONT YARD SETBACK	99.2m
CORNER YARD SETBACK	27.2m
REAR YARD SETBACK	3.3m
TOWER SEPARATION	18.6m
AMENITY AREA - PER UNIT	6.0 sq. m.
TOWER FOOTPRINT	955.9 sq. m.

**FULL SITE**

**GROSS BUILDING AREA**  
 (CITY OF OTTAWA'S DEFINITION)

EX. TOWER "A" - 20 STOREY	20,879.0 sq. m. 224,741 sq. ft.
EX. TOWER "B" - 17 STOREY	17,800.0 sq. m. 191,592 sq. ft.
NEW TOWER "C" - 25 STOREY	18,584.0 sq. m. 200,036 sq. ft.
<b>TOTAL AREA</b>	<b>57,263.0 sq. m. 616,375 sq. ft.</b>

FLOOR SPACE INDEX 2.2

**RESIDENTIAL UNITS**

EX. TOWER "A" - 20 STOREY	303
EX. TOWER "B" - 17 STOREY	235
NEW TOWER "C" - 25 STOREY	234
<b>TOTAL</b>	<b>772</b>

**PARKING SPACES**

EX. BUILDING - P2 LEVEL	242
EX. BUILDING - P1 LEVEL	238
EX. SURFACE SPACES	37
NEW P2 LEVEL	123
NEW P1 LEVEL	117
NEW SURFACE SPACES	34
<b>TOTAL</b>	<b>791</b>

**LOT COVERAGE**

PAVED SURFACE =	5,583.1 sq. m.	21.7%
TOWER FOOTPRINT =	4,139.1 sq. m.	16.1%
OTHER BUILDINGS / COVER RAMPS =	672.0 sq. m.	2.6%
LANDSCAPE OPEN SPACE =	15,291.8 sq. m.	59.6%
<b>TOTAL =</b>	<b>25,686.0 sq. m.</b>	<b>100.0%</b>

**PROJECT DEVELOPER**  
**Homestead Land Holdings Ltd.**  
 80 Johnson Street  
 Kingston, ON K7L 1X7  
 Tel: (613) 546-3146  
 Cell: (613) 329-0354  
 E-Mail: JMangan@homestead.ca

**LEGAL DESCRIPTION**  
 TOPOGRAPHIC PLAN OF SURVEY OF  
**PART OF LOT 20**  
**CONCESSION 2 (OTTAWA FRONT)**  
**GEOGRAPHIC TOWNSHIP OF NEPEAN AND**  
**PART OF LOTS 1 AND 2**  
**REGISTERED PLAN 482**  
**CITY OF OTTAWA**  
 Surveyed by Annis, O'Sullivan, Vollebek Ltd.

**URBAN PLANNER**  
**Fotenn Consulting**  
 396 Cooper Street  
 Suite 300  
 Ottawa, ON K2P 2H7  
 Tel: (613) 730-5709  
 E-Mail: zaki@fotenn.com

**PROPOSED - BUILDING "C"**

**BUILDING STATISTICS**

**GROSS BUILDING AREA**  
 (CITY OF OTTAWA'S DEFINITION)

PARKING LEVEL	0.0 sq. m. 0 sq. ft.
GROUND FLOOR	444.1 sq. m. 4,780 sq. ft.
2nd FLOOR	640.0 sq. m. 6,889 sq. ft.
3rd FLOOR	883.5 sq. m. 9,510 sq. ft.
4th - 21st FLOOR	18 x 791.26 sq. m. 18 x 8,517 sq. ft.
22nd - 24th FLOOR	3 x 791.26 sq. m. 3 x 8,517 sq. ft.
AMENITY / MECHANICAL PENTHOUSE	0 sq. m. 000 sq. ft.
<b>TOTAL AREA</b>	<b>18,584.0 sq. m. 200,036 sq. ft.</b>

**TOWER FOOTPRINT**  
 955.9 sq. m.  
10,289 sq. ft.

**UNIT STATISTICS**

STUDIO UNIT	0
1 BEDROOM UNIT	71
1 BEDROOM + DEN UNIT	24
2 BEDROOM UNIT	138
2 BEDROOM + DEN UNIT	1
<b>TOTAL</b>	<b>234</b>

**CAR PARKING**

**REQUIRED BY ZONING BY-LAW**

RESIDENCE	- 0.5 PER UNIT (234 UNITS) (AFTER 12 UNITS)	117
VISITOR	- 0.2 PER DWELLING UNIT (AFTER 12 UNITS)	44
<b>TOTAL</b>		<b>158</b>

**PROVIDED**

RESIDENCE	- 1.0 PER UNIT	230
VISITOR	- 0.2 PER DWELLING UNIT (AFTER 12 UNITS)	44
<b>TOTAL</b>		<b>274</b>

**BICYCLE PARKING**

**REQUIRED**

RESIDENCE	- 0.5 PER UNIT (234 UNITS)	117
<b>TOTAL</b>		<b>117</b>

**PROVIDED**

EXTERIOR	5
UNDERGROUND PARKING LEVEL	146
<b>TOTAL</b>	<b>151</b>

**AMENITY SPACE**

EXTERIOR COMMUNAL AT GRADE =	850.0 sq. m.
GROUND FLOOR COMMUNAL INTERIOR =	318.0 sq. m.
2nd FLOOR COMMUNAL INTERIOR =	496.0 sq. m.
25th FLOOR COMMUNAL EXTERIOR PATIO =	350.0 sq. m.
25th FLOOR COMMUNAL INTERIOR =	215.0 sq. m.
PRIVATE BALCONIES =	1,600.0 sq. m.
<b>TOTAL =</b>	<b>3,829.0 sq. m.</b>
<b>TOTAL COMMUNAL =</b>	<b>2,229.0 sq. m.</b>
REQUIRED - 6.0M <sup>2</sup> PER UNIT (234) =	1,404.0 sq. m.
REQUIRED COMMUNAL @ 50% =	702.0 sq. m.

**REFUSE REQUIREMENT** (234 UNITS)

GARBAGE	- 0.11 PER UNIT	26 YARDS
RECYCLING GMP	- 0.018 PER UNIT	5 YARDS
RECYCLING FIBER	- 0.038 PER UNIT	9 YARDS
COMPOST	- 240L PER 50 UNITS	5

IT IS THE RESPONSIBILITY OF THE APPROPRIATE CONTRACTOR TO CHECK AND VERIFY ALL DIMENSIONS ON SITE AND TO REPORT ALL ERRORS AND/OR OMISSIONS TO THE ARCHITECT.

ALL CONTRACTORS MUST COMPLY WITH ALL PERTINENT CODES AND BY-LAWS.

THIS DRAWING MAY NOT BE USED FOR CONSTRUCTION UNTIL SIGNED BY THE ARCHITECT.

DO NOT SCALE DRAWINGS.

COPYRIGHT RESERVED.

**NOTATION SYMBOLS:**

- INDICATES DRAWING NOTES, LISTED ON EACH SHEET.
- INDICATES ASSEMBLY TYPE; REFER TO TYPICAL ASSEMBLIES SCHEDULE.
- INDICATES WINDOW TYPE; REFER TO WINDOW ELEVATIONS AND DETAILS ON A900 SERIES.
- INDICATES DOOR TYPE; REFER TO DOOR SCHEDULE AND DETAILS ON A900 SERIES.
- DETAIL NUMBER
- TITLE
- DETAIL REFERENCE PAGE
- DETAIL CROSS REFERENCE PAGE

**GENERAL NOTES:**

- REFER TO TYPICAL ASSEMBLIES SHEET FOR WALL, PARTITION, ROOF CEILING & FLOOR TYPES.
- FOR DOOR TYPES AND HARDWARE REQUIREMENTS REFER TO DOOR SCHEDULE ON A900 SERIES.
- ALL INTERIOR DIMENSIONS ARE TAKEN FROM THE FACE OF DRYWALL.
- ALL EXTERIOR DIMENSIONS ARE TAKEN FROM THE FACE OF CLADDING.
- ALL EXTERIOR WALLS ARE TO BE TYPE 'W1' UNLESS NOTED OTHERWISE.
- ALL INTERIOR PARTITIONS ARE TO BE TYPE 'P1' UNLESS NOTED OTHERWISE.

**REVISIONS:**

No.	DESCRIPTION	DATE (MM/YY)
1	ISSUED FOR SITE PLAN CONTROL	2021-12
2	ISSUED FOR CONSULTANT REVIEW	2022-02-08
3	ISSUED FOR ZONING APPLICATION	2021-05-26

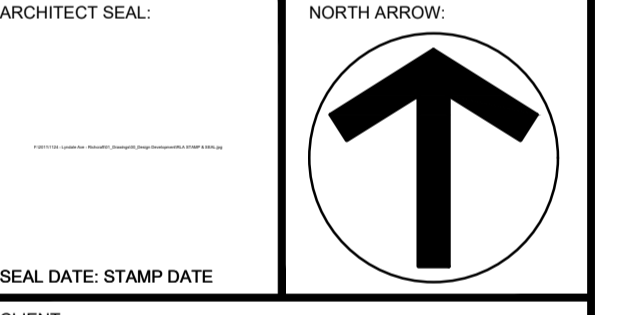

..HOMESTEAD LOGO.jpg

**Homestead Land Holdings Ltd.**  
 80 Johnson Street, Kingston

**PROJECT TITLE:**  
 1300 McWatters Road

OTTAWA ONTARIO

**SHEET TITLE:**  
 SITE PLAN  
 FULL SITE

**DRAWN:**  
 R.V.

**CHECKED:**  
 JS

**SCALE:**  
 1:500

**SHEET No.:**  
 SP-1

**PROJECT No.:**  
 1706

## Appendix C SANITARY SERVICING

### C.1 SANITARY SEWER DESIGN SHEET





SITE:  
**1300 & 1310 McWatters Road**

DATE: 2/25/2022  
 REVISION: 1  
 DESIGNED BY: NN  
 CHECKED BY: KS

**SANITARY SEWER  
 DESIGN SHEET  
 (City of Ottawa)**

FILE NUMBER: 160401668

DESIGN PARAMETERS			
MAX PEAK FACTOR (RES.)=	4.0	AVG. DAILY FLOW / PERSON	280 l/p/day
MIN PEAK FACTOR (RES.)=	2.0	COMMERCIAL	28,000 l/ha/day
PEAKING FACTOR (INDUSTRIAL):	2.4	INDUSTRIAL (HEAVY)	55,000 l/ha/day
PEAKING FACTOR (ICI >20%):	1.5	INDUSTRIAL (LIGHT)	35,000 l/ha/day
PERSONS / 1 BEDROOM	1.4	INSTITUTIONAL	28,000 l/ha/day
PERSONS / 2 BEDROOM	2.1	INFILTRATION	0.33 l/s/ha
PERSONS / 3 BEDROOM	3.1		
MINIMUM VELOCITY	0.60 m/s		
MAXIMUM VELOCITY	3.00 m/s		
MANNINGS n	0.013		
BEDDING CLASS	B		
MINIMUM COVER	2.50 m		
HARMON CORRECTION FACTOR	0.8		

LOCATION			RESIDENTIAL AREA AND POPULATION								COMM/AMENITY		INDUSTRIAL (L)		INDUSTRIAL (H)		INSTITUTIONAL		GREEN / STREET		C+H	INFILTRATION			TOTAL	PIPE									
AREA ID NUMBER	FROM M.H.	TO M.H.	AREA (ha)	1 BEDROOM	BEDROOM (1 Bed + Den)	3 BEDROOM (2 Bed + Den)	POP.	CUMULATIVE AREA (ha)	POP.	PEAK FACT.	PEAK FLOW (l/s)	AREA (ha)	ACCU. AREA (ha)	AREA (ha)	ACCU. AREA (ha)	AREA (ha)	ACCU. AREA (ha)	AREA (ha)	ACCU. AREA (ha)	AREA (ha)	ACCU. AREA (ha)	PEAK FLOW (l/s)	TOTAL AREA (ha)	ACCU. AREA (ha)	INFILT. FLOW (l/s)	FLOW (l/s)	LENGTH (m)	DIA (mm)	MATERIAL	CLASS	SLOPE (%)	CAP. (FULL) (l/s)	CAP. V. PEAK FLOW (%)	VEL. (FULL) (m/s)	VEL. (ACT.) (m/s)
PROPOSED BLDG	BLDG	EX SAN	0.138	71	162	1	445	0.14	445	3.20	4.61	0.383	0.383	0.00	0.00	0.00	0.00	0.00	0.00	0.54	0.54	0.19	0.680	0.68	0.22	15.09	13.8	200	PVC	SDR 35	1.00	33.4	45.12%	1.05	0.87

Note: Total flow include estimated peak flow of 10.06L/s from Building A and B

## **C.2 CORRESPONDENCE WITH CITY ON SANITARY SEWER CAPACITY**



## Nwanise, Nwanise

---

**From:** Nwanise, Nwanise  
**Sent:** Thursday, June 10, 2021 3:09 PM  
**To:** Armstrong, Justin  
**Cc:** Rathnasooriya, Thakshika (Thakshika.Rathnasooriya@stantec.com); Gillis, Sheridan  
**Subject:** RE: 1300 McWatters - Sanitary servicing

Hi Justin,

Thanks for your feedback.

Regards,

**Nwanise Nwanise**, EIT  
Engineering intern, Community Development

Mobile: (647) 400-1759  
[nwanise.nwanise@stantec.com](mailto:nwanise.nwanise@stantec.com)

Stantec  
400 - 1331 Clyde Avenue  
Ottawa ON K2C 3G4



**Better Together, Even If We're Apart.** [Read more](#) about Stantec's COVID-19 response, including remote working and business continuity measures.

The content of this email is the confidential property of Stantec and should not be copied, modified, retransmitted, or used for any purpose except with Stantec's written authorization. If you are not the intended recipient, please delete all copies and notify us immediately.

---

**From:** Armstrong, Justin <justin.armstrong@ottawa.ca>  
**Sent:** Thursday, June 10, 2021 2:11 PM  
**To:** Nwanise, Nwanise <Nwanise.Nwanise@stantec.com>  
**Cc:** Elsayed, Ahmed <ahmed.elsayed@ottawa.ca>  
**Subject:** RE: 1300 McWatters - Sanitary servicing

Hi Nwanise,

I checked in with our Asset Management Branch and the 4.61 l/s peak flow you are proposing below is acceptable. Thanks for reaching out to verify.

Have a great afternoon.

Justin

**Justin Armstrong, E.I.T.**

Project Manager

Planning, Infrastructure and Economic Development Department - Services de la planification, de l'infrastructure et du développement économique

Development Review - West Branch

City of Ottawa | Ville d'Ottawa

110 Laurier Avenue West Ottawa, ON | 110, avenue. Laurier Ouest. Ottawa (Ontario) K1P 1J1

613.580.2424 ext./poste 21746, [justin.armstrong@ottawa.ca](mailto:justin.armstrong@ottawa.ca)

---

**From:** Nwanise, Nwanise <[Nwanise.Nwanise@stantec.com](mailto:Nwanise.Nwanise@stantec.com)>  
**Sent:** June 3, 2021 5:30 PM  
**To:** Armstrong, Justin <[justin.armstrong@ottawa.ca](mailto:justin.armstrong@ottawa.ca)>  
**Subject:** FW: 1300 McWatters - Sanitary servicing

Hi Justin,

I got an auto reply from Ahmed suggesting we forward any urgent email to you. Could please assist us with looking into the request in the email below?

We appreciate your time looking into this for us.

Regards,

**Nwanise Nwanise**,EIT  
Engineering intern, Community Development

Mobile: (647) 400-1759  
[nwanise.nwanise@stantec.com](mailto:nwanise.nwanise@stantec.com)

Stantec  
400 - 1331 Clyde Avenue  
Ottawa ON K2C 3G4



**Better Together, Even If We're Apart.** [Read more](#) about Stantec's COVID-19 response, including remote working and business continuity measures.

The content of this email is the confidential property of Stantec and should not be copied, modified, retransmitted, or used for any purpose except with Stantec's written authorization. If you are not the intended recipient, please delete all copies and notify us immediately.

---

**From:** Nwanise, Nwanise  
**Sent:** Thursday, June 3, 2021 2:14 PM  
**To:** [ahmed.elsayed@ottawa.ca](mailto:ahmed.elsayed@ottawa.ca)  
**Cc:** Gillis, Sheridan <[Sheridan.Gillis@stantec.com](mailto:Sheridan.Gillis@stantec.com)>; Johnson, Warren ([Warren.Johnson@stantec.com](mailto:Warren.Johnson@stantec.com)) <[Warren.Johnson@stantec.com](mailto:Warren.Johnson@stantec.com)>; Mott, Peter ([Peter.Mott@stantec.com](mailto:Peter.Mott@stantec.com)) <[Peter.Mott@stantec.com](mailto:Peter.Mott@stantec.com)>  
**Subject:** 1300 McWatters - Sanitary servicing

Good afternoon Ahmed,

Hope you are keeping well.

We are preparing an adequacy of services report in support of the proposed development on 1300 & 1310 McWatters Road. We would like to confirm if there is sufficient capacity downstream of the existing 250 mm diameter sanitary sewer on Lisa Avenue to receive an additional flow of 4.61L/s from the site being the estimated sanitary peak flow from the development.

The proposed development area (0.68 ha) consists of a 25-storey residential high-rise building. The building is to contain a total of 235 units consisting of 97 one-bedroom units, 138 two-bedroom units, and 1556 m<sup>2</sup> of communal amenity space. Internal circulation in the proposed development will be provided by access lanes for vehicles, surface parking for 29 vehicles, and two levels of underground parking with pedestrian access to the building.

Please find our sanitary sewer design sheet and location map attached for your information.

Thank you.

Regards,

**Nwanise Nwanise**,EIT

Engineering intern, Community Development

Direct: (647) 400-1759  
Mobile: (647) 400-1759  
[nwanise.nwanise@stantec.com](mailto:nwanise.nwanise@stantec.com)

Stantec  
400 - 1331 Clyde Avenue  
Ottawa ON K2C 3G4



**Better Together, Even If We're Apart.** [Read more](#) about Stantec's COVID-19 response, including remote working and business continuity measures.

The content of this email is the confidential property of Stantec and should not be copied, modified, retransmitted, or used for any purpose except with Stantec's written authorization. If you are not the intended recipient, please delete all copies and notify us immediately.

,

This e-mail originates from the City of Ottawa e-mail system. Any distribution, use or copying of this e-mail or the information it contains by other than the intended recipient(s) is unauthorized. Thank you.

Le présent courriel a été expédié par le système de courriels de la Ville d'Ottawa. Toute distribution, utilisation ou reproduction du courriel ou des renseignements qui s'y trouvent par une personne autre que son destinataire prévu est interdite. Je vous remercie de votre collaboration.

,

## Appendix D STORMWATER SERVICING AND MANAGEMENT

### D.1 MODIFIED RATIONAL METHOD CALCUALTIONS





**Roof Drain Design Calculation Sheet**

**Project #160401668, 1300 & 1310 McWatters  
Roof Drain Design Sheet, Area ROOF-1  
Standard Watts Model R1100 Accuflow Roof Drain**

Rating Curve				Volume Estimation				Water Depth (m)
Elevation (m)	Discharge Rate (cu.m/s)	Outlet Discharge (cu.m/s)	Storage (cu. m)	Elevation (m)	Area (sq. m)	Volume (cu. m)		
						Increment	Accumulated	
0.000	0.0000	0.0000	0	0.000	0	0	0	0.000
0.025	0.0004	0.0004	0	0.025	3	0	0	0.025
0.050	0.0008	0.0008	0	0.050	12	0	0	0.050
0.075	0.0012	0.0012	1	0.075	26	0	1	0.075
0.100	0.0015	0.0015	2	0.100	46	1	2	0.100
0.125	0.0019	0.0019	3	0.125	72	1	3	0.125
0.150	0.0023	0.0023	5	0.150	104	2	5	0.150

Drawdown Estimate			
Total Volume (cu.m)	Total Time (sec)	Vol (cu.m)	Detention Time (hr)
0.0	0.0	0.0	0
0.2	219.3	0.2	0.06091
0.6	396.8	0.5	0.17114
1.5	579.6	0.9	0.33213
3.0	764.4	1.5	0.54445
5.2	950.3	2.2	0.80841

**Rooftop Storage Summary**

Total Building Area (sq.m)		129.92	
Assume Available Roof Area (sq.m)	80%	103.936	
Roof Imperviousness		0.99	
Roof Drain Requirement (sq.m/Notch)		900	
Number of Roof Notches*		1	
Max. Allowable Depth of Roof Ponding (m)		0.15	* As per Ontario Building Code section OBC 7.4.10.4.(2)(c).
Max. Allowable Storage (cu.m)		5	
Estimated 100 Year Drawdown Time (h)		0.5	

**From Watts Drain Catalogue**

Head (m)	L/s				
	Open	75%	50%	25%	Closed
0.025	0.31545	0.31545	0.31545	0.31545	0.31545
0.050	0.6309	0.6309	0.6309	0.6309	0.6309
0.075	0.94635	0.86749	0.78863	0.70976	0.6309
0.100	1.2618	1.10408	0.94635	0.78863	0.6309
0.125	1.57726	1.34067	1.10408	0.86749	0.6309
0.150	1.89271	1.57726	1.2618	0.94635	0.6309

\* Note: Number of drains can be reduced if multiple-notch drain used.

Calculation Results	5yr	100yr	Available
Qresult (cu.m/s)	0.001	0.002	-
Depth (m)	0.090	0.124	0.150
Volume (cu.m)	1.2	2.9	5.2
Draintime (hrs)	0.3	0.5	

**Roof Drain Design Calculation Sheet**

**Project #160401668, 1300 & 1310 McWatters  
Roof Drain Design Sheet, Area ROOF-2  
Standard Zurn Model Z-105-5 Control-Flo Single Notch Roof Drain**

Rating Curve				Volume Estimation				Water Depth (m)
Elevation (m)	Discharge Rate (cu.m/s)	Outlet Discharge (cu.m/s)	Storage (cu. m)	Elevation (m)	Area (sq. m)	Volume (cu. m)		
						Increment	Accumulated	
0.000	0.0000	0.0000	0	0.000	0	0	0	0.000
0.025	0.0004	0.0015	0	0.025	7	0	0	0.025
0.050	0.0008	0.0031	0	0.050	26	0	0	0.050
0.075	0.0012	0.0046	1	0.075	59	1	1	0.075
0.100	0.0015	0.0061	3	0.100	104	2	3	0.100
0.125	0.0019	0.0077	7	0.125	163	3	7	0.125
0.150	0.0023	0.0092	12	0.150	234	5	12	0.150

Drawdown Estimate			
Total Volume (cu.m)	Total Time (sec)	Vol (cu.m)	Detention Time (hr)
0.0	0.0	0.0	0
0.4	123.6	0.4	0.03433
1.4	223.6	1.0	0.09646
3.4	326.6	2.0	0.18719
6.7	430.8	3.3	0.30686
11.7	535.6	4.9	0.45564

**Rooftop Storage Summary**

Total Building Area (sq.m)		292.9	
Assume Available Roof Area (sq.m)	80%	234.32	
Roof Imperviousness		0.99	
Roof Drain Requirement (sq.m/Notch)		900	
Number of Roof Notches*		4	
Max. Allowable Depth of Roof Ponding (m)		0.15	* As per Ontario Building Code section OBC 7.4.10.4.(2)(c).
Max. Allowable Storage (cu.m)		12	
Estimated 100 Year Drawdown Time (h)		0.2	

**From Watts Drain Catalogue**

Head (m)	L/s		Open		75%		50%		25% Closed	
0.025	0.31545	0.31545	0.31545	0.31545	0.31545	0.31545	0.31545	0.31545	0.31545	0.31545
0.050	0.6309	0.6309	0.6309	0.6309	0.6309	0.6309	0.6309	0.6309	0.6309	0.6309
0.075	0.94635	0.86749	0.86749	0.78863	0.70976	0.6309	0.55209	0.47343	0.39477	0.31611
0.100	1.2618	1.10408	1.10408	0.94635	0.78863	0.6309	0.55209	0.47343	0.39477	0.31611
0.125	1.57726	1.34067	1.34067	1.10408	0.94635	0.78863	0.6309	0.55209	0.47343	0.39477
0.150	1.89271	1.57726	1.57726	1.34067	1.10408	0.94635	0.78863	0.6309	0.55209	0.47343

\* Note: Number of drains can be reduced if multiple-notch drain used.

Calculation Results	5yr	100yr	Available
Qresult (cu.m/s)	0.005	0.007	-
Depth (m)	0.078	0.109	0.150
Volume (cu.m)	1.7	4.7	11.7
Draintime (hrs)	0.1	0.2	

Roof Drain Design Calculation Sheet

**Project #160401668, 1300 & 1310 McWatters**  
**Roof Drain Design Sheet, Area ROOF-3**  
**Standard Watts Model R1100 Accuflow Roof Drain**

Rating Curve				Volume Estimation				Water Depth (m)
Elevation (m)	Discharge Rate (cu.m/s)	Outlet Discharge (cu.m/s)	Storage (cu. m)	Elevation (m)	Area (sq. m)	Volume (cu. m)		
						Increment	Accumulated	
0.000	0.0000	0.0000	0	0.000	0	0	0	0.000
0.025	0.0003	0.0013	0	0.025	23	0	0	0.025
0.050	0.0006	0.0025	2	0.050	93	1	2	0.050
0.075	0.0008	0.0032	5	0.075	210	4	5	0.075
0.100	0.0009	0.0038	12	0.100	374	7	12	0.100
0.125	0.0011	0.0044	24	0.125	584	12	24	0.125
0.150	0.0013	0.0050	42	0.150	841	18	42	0.150

Drawdown Estimate			
Total Volume (cu.m)	Total Time (sec)	Vol (cu.m)	Detention Time (hr)
0.0	0.0	0.0	0
1.4	540.0	1.4	0.15
5.1	1172.6	3.7	0.47571
12.3	1902.9	7.2	1.00428
24.1	2689.0	11.9	1.75122
41.9	3510.0	17.7	2.72622

**Rooftop Storage Summary**

Total Building Area (sq.m)		1051.26	
Assume Available Roof Area (sq. m)	80%	841.008	
Roof Imperviousness		0.99	
Roof Drain Requirement (sq.m/Notch)		900	
Number of Roof Notches*		4	
Max. Allowable Depth of Roof Ponding (m)		0.15	* As per Ontario Building Code section OBC 7.4.10.4.(2)(c).
Max. Allowable Storage (cu.m)		42	
Estimated 100 Year Drawdown Time (h)		2.7	

**From Watts Drain Catalogue**

Head (m)	L/s				
	Open	<b>75%</b>	50%	25%	Closed
0.025	0.3155	<b>0.3155</b>	0.3155	0.3155	0.3155
0.050	0.6309	<b>0.6309</b>	0.6309	0.6309	0.6309
0.075	0.9464	<b>0.8675</b>	0.7886	0.7098	0.6309
0.100	1.2618	<b>1.1041</b>	0.9464	0.7886	0.6309
0.125	1.5773	<b>1.3407</b>	1.1041	0.8675	0.6309
0.150	1.8927	<b>1.5773</b>	1.2618	0.9464	0.6309

\* Note: Number of drains can be reduced if multiple-notch drain used.

**Calculation Results**

	5yr	100yr	Available
Qresult (cu.m/s)	0.004	0.005	-
Depth (m)	0.112	0.149	0.150
Volume (cu.m)	18.2	41.0	42.1
Drain time (hrs)	1.4	2.7	

## Stormwater Management Calculations

File No: 160401668  
 Project: 1300 & 1310 McWatters  
 Date: 19-Jul-22

SWM Approach:  
 Post-development to Pre-development flows

**Post-Development Site Conditions:**

**Overall Runoff Coefficient for Site and Sub-Catchment Areas**

Runoff Coefficient Table									
Catchment Type	Sub-catchment Area		Area (ha) "A"	Runoff Coefficient "C"		"A x C"	Overall Runoff Coefficient		
	ID / Description								
Uncontrolled - Tributary	CSTN-1	Hard	0.013	0.9	0.012				
		Soft	0.007	0.2	0.001				
		Subtotal			0.02		0.0132	0.660	
Uncontrolled - Tributary	UNK-1	Hard	0.043	0.9	0.039				
		Soft	0.077	0.2	0.015				
		Subtotal			0.12		0.0539028	0.45	
Roof	ROOF-2	Hard	0.029	0.9	0.026				
		Soft	0.000	0.2	0.000				
		Subtotal			0.03		0.026361	0.90	
Roof	ROOF-1	Hard	0.013	0.9	0.012				
		Soft	0.000	0.2	0.000				
		Subtotal			0.01		0.0116928	0.90	
Controlled - Tributary	AREA-1	Hard	0.189	0.9	0.170				
		Soft	0.151	0.2	0.030				
		Subtotal			0.34		0.2006	0.59	
Roof	ROOF - 3	Hard	0.105	0.9	0.095				
		Soft	0.000	0.2	0.000				
		Subtotal			0.11		0.0946134	0.90	
<b>Total</b>				<b>0.627</b>		<b>0.400</b>		<b>0.64</b>	
<b>Overall Runoff Coefficient= C:</b>									

Total Roof Areas	0.147 ha
Total Tributary Surface Areas (Controlled and Uncontrolled)	0.360 ha
Total Tributary Area to Outlet	0.507 ha
 Total Uncontrolled Areas (Non-Tributary)	 0.120 ha
 Total Site	 0.627 ha

# Stormwater Management Calculations

**Project #160401668, 1300 & 1310 McWatters**  
**Modified Rational Method Calculators for Storage**

5 yr Intensity City of Ottawa	$I = a/(t + b)^c$	a = 998.071	t (min)	I (mm/hr)
		b = 6.053	10	104.19
		c = 0.814	20	70.25
			30	53.93
			40	44.18
			50	37.65
			60	32.94
			70	29.37
			80	26.56
			90	24.29
			100	22.41
			110	20.82
			120	19.47

**5 YEAR Predevelopment Target Release from Portion of Site**

Subdrainage Area: Predevelopment Tributary Area to Outlet  
 Area (ha): 0.63  
 C: 0.50

Target release from site

tc (min)	I (5 yr) (mm/hr)	Qtarget (L/s)
10	104.19	90.84

**5 YEAR Modified Rational Method for Entire Site**

Subdrainage Area: CSTN-1 Uncontrolled - Tributary  
 Area (ha): 0.02  
 C: 0.66

tc (min)	I (5 yr) (mm/hr)	Qactual (L/s)	Qrelease (L/s)	Qstored (L/s)	Vstored (m <sup>3</sup> )
10	104.19	3.82	3.82		
20	70.25	2.58	2.58		
30	53.93	1.98	1.98		
40	44.18	1.62	1.62		
50	37.65	1.38	1.38		
60	32.94	1.21	1.21		
70	29.37	1.08	1.08		
80	26.56	0.97	0.97		
90	24.29	0.89	0.89		
100	22.41	0.82	0.82		
110	20.82	0.76	0.76		
120	19.47	0.71	0.71		

Subdrainage Area: UNK-1 Uncontrolled - Tributary  
 Area (ha): 0.12  
 C: 0.45

tc (min)	I (5 yr) (mm/hr)	Qactual (L/s)	Qrelease (L/s)	Qstored (L/s)	Vstored (m <sup>3</sup> )
10	104.19	15.61	15.61		
20	70.25	10.53	10.53		
30	53.93	8.08	8.08		
40	44.18	6.62	6.62		
50	37.65	5.64	5.64		
60	32.94	4.94	4.94		
70	29.37	4.40	4.40		
80	26.56	3.98	3.98		
90	24.29	3.64	3.64		
100	22.41	3.36	3.36		
110	20.82	3.12	3.12		
120	19.47	2.92	2.92		

Subdrainage Area: ROOF-2 Roof  
 Area (ha): 0.03 Maximum Storage Depth: 150 mm  
 C: 0.90

tc (min)	I (5 yr) (mm/hr)	Qactual (L/s)	Qrelease (L/s)	Qstored (L/s)	Vstored (m <sup>3</sup> )	Depth (mm)
10	104.19	7.64	4.79	2.84	1.71	78.01
20	70.25	5.15	4.17	0.98	1.17	67.90
30	53.93	3.95	3.54	0.41	0.75	57.58
40	44.18	3.24	3.06	0.18	0.43	49.77
50	37.65	2.76	2.65	0.11	0.33	43.12
60	32.94	2.41	2.34	0.07	0.25	38.15
70	29.37	2.15	2.11	0.05	0.20	34.28
80	26.56	1.95	1.92	0.03	0.15	31.18
90	24.29	1.78	1.76	0.02	0.11	28.64
100	22.41	1.64	1.63	0.01	0.08	26.52
110	20.82	1.53	1.52	0.01	0.05	24.70
120	19.47	1.43	1.42	0.01	0.05	23.11

Storage: Roof Storage

Depth (mm)	Head (m)	Discharge (L/s)	Vreq (cu. m)	Vavail (cu. m)	Discharge Check
78.01	0.08	4.79	1.71	11.72	0.00

5-year Water Level

Subdrainage Area: ROOF-1 Roof  
 Area (ha): 0.01 Maximum Storage Depth: 150 mm  
 C: 0.90

tc (min)	I (5 yr) (mm/hr)	Qactual (L/s)	Qrelease (L/s)	Qstored (L/s)	Vstored (m <sup>3</sup> )	Depth (mm)
10	104.19	3.39	1.39	2.00	1.20	90.42
20	70.25	2.28	1.35	0.93	1.12	88.11
30	53.93	1.75	1.26	0.50	0.89	81.83
40	44.18	1.44	1.16	0.28	0.67	75.45
50	37.65	1.22	1.05	0.18	0.53	68.26
60	32.94	1.07	0.96	0.12	0.42	62.20
70	29.37	0.95	0.89	0.08	0.32	57.15
80	26.56	0.86	0.81	0.05	0.25	52.89
90	24.29	0.79	0.75	0.03	0.19	49.15
100	22.41	0.73	0.70	0.03	0.16	45.65
110	20.82	0.68	0.66	0.02	0.14	42.66
120	19.47	0.63	0.62	0.02	0.13	40.06

Storage: Roof Storage

Depth (mm)	Head (m)	Discharge (L/s)	Vreq (cu. m)	Vavail (cu. m)	Discharge Check
90.42	0.09	1.39	1.20	5.20	0.00

5-year Water Level

**Project #160401668, 1300 & 1310 McWatters**  
**Modified Rational Method Calculators for Storage**

100 yr Intensity City of Ottawa	$I = a/(t + b)^c$	a = 1735.688	t (min)	I (mm/hr)
		b = 6.014	10	178.56
		c = 0.820	20	119.95
			30	91.87
			40	75.15
			50	63.95
			60	55.89
			70	49.79
			80	44.99
			90	41.11
			100	37.90
			110	35.20
			120	32.89

**100 YEAR Predevelopment Target Release from Portion of Site**

Subdrainage Area: Predevelopment Tributary Area to Outlet  
 Area (ha): 0.63  
 C: 0.50

Target release from site

tc (min)	I (100 yr) (mm/hr)	Q100yr (L/s)
10	104.19	90.84

**100 YEAR Modified Rational Method for Entire Site**

Subdrainage Area: CSTN-1 Uncontrolled - Tributary  
 Area (ha): 0.02  
 C: 0.83

tc (min)	I (100 yr) (mm/hr)	Qactual (L/s)	Qrelease (L/s)	Qstored (L/s)	Vstored (m <sup>3</sup> )
10	178.56	8.19	8.19		
20	119.95	5.50	5.50		
30	91.87	4.21	4.21		
40	75.15	3.45	3.45		
50	63.95	2.93	2.93		
60	55.89	2.56	2.56		
70	49.79	2.28	2.28		
80	44.99	2.06	2.06		
90	41.11	1.89	1.89		
100	37.90	1.74	1.74		
110	35.20	1.61	1.61		
120	32.89	1.51	1.51		

Subdrainage Area: UNK-1 Uncontrolled - Tributary  
 Area (ha): 0.12  
 C: 0.56

tc (min)	I (100 yr) (mm/hr)	Qactual (L/s)	Qrelease (L/s)	Qstored (L/s)	Vstored (m <sup>3</sup> )
10	178.56	33.45	33.45		
20	119.95	22.47	22.47		
30	91.87	17.21	17.21		
40	75.15	14.08	14.08		
50	63.95	11.98	11.98		
60	55.89	10.47	10.47		
70	49.79	9.33	9.33		
80	44.99	8.43	8.43		
90	41.11	7.70	7.70		
100	37.90	7.10	7.10		
110	35.20	6.59	6.59		
120	32.89	6.16	6.16		

Subdrainage Area: ROOF-2 Roof  
 Area (ha): 0.03 Maximum Storage Depth: 150 mm  
 C: 1.00

tc (min)	I (100 yr) (mm/hr)	Qactual (L/s)	Qrelease (L/s)	Qstored (L/s)	Vstored (m <sup>3</sup> )	Depth (mm)
10	178.56	14.54	6.71	7.83	4.70	109.25
20	119.95	9.77	6.41	3.36	4.03	104.25
30	91.87	7.48	5.80	1.68	3.02	94.42
40	75.15	6.12	5.19	0.93	2.23	84.49
50	63.95	5.21	4.69	0.52	1.57	76.26
60	55.89	4.55	4.22	0.33	1.20	68.64
70	49.79	4.05	3.83	0.22	0.94	62.33
80	44.99	3.66	3.51	0.15	0.73	57.15
90	41.11	3.35	3.25	0.10	0.55	52.83
100	37.90	3.09	3.02	0.07	0.42	49.09
110	35.20	2.87	2.81	0.06	0.37	45.74
120	32.89	2.68	2.63	0.05	0.33	42.86

Storage: Roof Storage

Depth (mm)	Head (m)	Discharge (L/s)	Vreq (cu. m)	Vavail (cu. m)	Discharge Check
109.25	0.11	6.71	4.70	11.72	0.00

100-year Water Level

Subdrainage Area: ROOF-1 Roof  
 Area (ha): 0.01 Maximum Storage Depth: 150 mm  
 C: 1.00

tc (min)	I (100 yr) (mm/hr)	Qactual (L/s)	Qrelease (L/s)	Qstored (L/s)	Vstored (m <sup>3</sup> )	Depth (mm)
10	178.56	6.45	1.85	4.59	2.76	120.73
20	119.95	4.33	1.90	2.43	2.92	123.54
30	91.87	3.32	1.83	1.49	2.67	119.32
40	75.15	2.71	1.74	0.97	2.33	113.47
50	63.95	2.31	1.65	0.66	1.98	107.46
60	55.89	2.02	1.56	0.46	1.64	101.74
70	49.79	1.80	1.47	0.33	1.38	95.62
80	44.99	1.62	1.38	0.25	1.18	89.82
90	41.11	1.48	1.30	0.18	0.99	84.68
100	37.90	1.37	1.23	0.14	0.83	80.10
110	35.20	1.27	1.17	0.10	0.69	76.01
120	32.89	1.19	1.11	0.08	0.59	71.98

Storage: Roof Storage

Depth (mm)	Head (m)	Discharge (L/s)	Vreq (cu. m)	Vavail (cu. m)	Discharge Check
123.54	0.12	1.90	2.92	5.20	0.00

100-year Water Level

# Stormwater Management Calculations

**Project #160401668, 1300 & 1310 McWatters**  
**Modified Rational Method Calculators for Storage**

<b>Subdrainage Area:</b> AREA-1		Controlled - Tributary					
<b>Area (ha):</b> 0.34							
<b>C:</b> 0.59							
tc (min)	I (5 yr) (mm/hr)	Qactual (L/s)	Qrelease (L/s)	Qstored (L/s)	Vstored (m <sup>3</sup> )		
10	104.19	61.93	42.00	19.93	<b>11.96</b>		
20	70.25	41.75	42.00	0.00	0.00		
30	53.93	32.05	42.00	0.00	0.00		
40	44.18	26.26	42.00	0.00	0.00		
50	37.65	22.38	42.00	0.00	0.00		
60	32.94	19.58	42.00	0.00	0.00		
70	29.37	17.46	42.00	0.00	0.00		
80	26.56	15.79	42.00	0.00	0.00		
90	24.29	14.44	42.00	0.00	0.00		
100	22.41	13.32	42.00	0.00	0.00		
110	20.82	12.38	42.00	0.00	0.00		
120	19.47	11.57	42.00	0.00	0.00		
		<b>Stage</b>	<b>Head (m)</b>	<b>Discharge (L/s)</b>	<b>Vreq (cu. m)</b>	<b>Vavail (cu. m)</b>	<b>Volume Check</b>
5-year Water Level		N/A	N/A	42.00	11.96	57.00	OK

<b>Subdrainage Area:</b> ROOF - 3		Roof					
<b>Area (ha):</b> 0.11		Maximum Storage Depth: 150 mm					
<b>C:</b> 0.90							
tc (min)	I (5 yr) (mm/hr)	Qactual (L/s)	Qrelease (L/s)	Qstored (L/s)	Vstored (m <sup>3</sup> )	Depth (mm)	
10	104.19	27.41	3.87	23.53	14.12	103.5 0.00	
20	70.25	18.48	4.04	14.43	17.32	110.2 0.00	
30	53.93	14.18	4.09	10.10	<b>18.17</b>	112.0 0.00	
40	44.18	11.62	4.08	7.54	18.09	111.9 0.00	
50	37.65	9.90	4.06	5.85	17.54	110.7 0.00	
60	32.94	8.66	4.01	4.65	16.75	109.0 0.00	
70	29.37	7.73	3.96	3.76	15.80	107.0 0.00	
80	26.56	6.99	3.91	3.08	14.77	104.9 0.00	
90	24.29	6.39	3.85	2.54	13.70	102.6 0.00	
100	22.41	5.89	3.79	2.10	12.60	100.3 0.00	
110	20.82	5.48	3.71	1.76	11.64	97.1 0.00	
120	19.47	5.12	3.63	1.49	10.71	93.9 0.00	
Storage: Roof Storage		<b>Depth (mm)</b>	<b>Head (m)</b>	<b>Discharge (L/s)</b>	<b>Vreq (cu. m)</b>	<b>Vavail (cu. m)</b>	<b>Discharge Check</b>
5-year Water Level		112.03	0.11	4.09	18.17	42.05	0.00

SUMMARY TO OUTLET			
Tributary Area	0.507 ha	Required	Vavailable*
Total 5yr Flow to Sewer	52 L/s	33	116 m <sup>3</sup> Ok
Non-Tributary Area	0.120 ha		
Total 5yr Flow Uncontrolled	16 L/s		
Total Area	0.627 ha		
Total 5yr Flow Target	68 L/s		
	91 L/s		

**Project #160401668, 1300 & 1310 McWatters**  
**Modified Rational Method Calculators for Storage**

<b>Subdrainage Area:</b> AREA-1		Controlled - Tributary					
<b>Area (ha):</b> 0.34							
<b>C:</b> 0.74							
tc (min)	I (100 yr) (mm/hr)	Qactual (L/s)	Qrelease (L/s)	Qstored (L/s)	Vstored (m <sup>3</sup> )		
10	178.56	132.66	42.00	90.66	54.40		
20	119.95	89.12	42.00	47.12	<b>56.54</b>		
30	91.87	68.25	42.00	26.25	47.26		
40	75.15	55.83	42.00	13.83	33.19		
50	63.95	47.52	42.00	5.52	16.55		
60	55.89	41.53	42.00	0.00	0.00		
70	49.79	36.99	42.00	0.00	0.00		
80	44.99	33.43	42.00	0.00	0.00		
90	41.11	30.54	42.00	0.00	0.00		
100	37.90	28.16	42.00	0.00	0.00		
110	35.20	26.15	42.00	0.00	0.00		
120	32.89	24.44	42.00	0.00	0.00		
		<b>Stage</b>	<b>Head (m)</b>	<b>Discharge (L/s)</b>	<b>Vreq (cu. m)</b>	<b>Vavail (cu. m)</b>	<b>Volume Check</b>
100-year Water Level		N/A	N/A	42.00	56.54	57.00	OK

<b>Subdrainage Area:</b> ROOF - 3		Roof					
<b>Area (ha):</b> 0.11		Maximum Storage Depth: 150 mm					
<b>C:</b> 1.00							
tc (min)	I (100 yr) (mm/hr)	Qactual (L/s)	Qrelease (L/s)	Qstored (L/s)	Vstored (m <sup>3</sup> )	Depth (mm)	
10	178.56	52.18	4.57	47.62	28.57	131.0 0.00	
20	119.95	35.06	4.84	30.21	36.26	141.8 0.00	
30	91.87	26.85	4.95	21.90	39.41	146.3 0.00	
40	75.15	21.96	5.00	16.96	40.71	148.1 0.00	
50	63.95	18.69	5.01	13.68	<b>41.04</b>	148.6 0.00	
60	55.89	16.34	5.00	11.33	40.80	148.2 0.00	
70	49.79	14.55	4.98	9.57	40.19	147.4 0.00	
80	44.99	13.15	4.95	8.20	39.35	146.2 0.00	
90	41.11	12.01	4.92	7.10	38.34	144.8 0.00	
100	37.90	11.08	4.87	6.20	37.21	143.2 0.00	
110	35.20	10.29	4.83	5.46	36.01	141.5 0.00	
120	32.89	9.61	4.79	4.83	34.75	139.7 0.00	
Storage: Roof Storage		<b>Depth (mm)</b>	<b>Head (m)</b>	<b>Discharge (L/s)</b>	<b>Vreq (cu. m)</b>	<b>Vavail (cu. m)</b>	<b>Discharge Check</b>
100-year Water Level		148.57	0.15	5.01	41.04	42.05	0.00

SUMMARY TO OUTLET			
Tributary Area	0.507 ha	Required	Vavailable*
Total 100yr Flow to Sewer	56 L/s	105	116 m <sup>3</sup> Ok
Non-Tributary Area	0.120 ha		
Total 100yr Flow Uncontrolled	33 L/s		
Total Area	0.627 ha		
Total 100yr Flow Target	89 L/s		
	91 L/s		

## **D.2 MODIFIED RATIONAL METHOD CALCULATIONS (SOUTHERN PORTION)**



## Stormwater Management Calculations

File No: 160401668  
 Project: 1300 MCWATTERS ROAD  
 Date: 01-Mar-22

SWM Approach:  
 Post-development to Pre-development flows

**Post-Development Site Conditions:**

**Overall Runoff Coefficient for Site and Sub-Catchment Areas**

Runoff Coefficient Table								
Sub-catchment Area	Area (ha) "A"	Runoff Coefficient "C"	"A x C"	Overall Runoff Coefficient				
Catchment Type	ID / Description							
Uncontrolled - Tributary	EX-3	Hard	0.035	0.9	0.031			
		Soft	0.055	0.2	0.011			
	Subtotal		0.09		0.0423	0.470		
Uncontrolled - Tributary	EX-2	Hard	0.261	0.9	0.235			
		Soft	0.309	0.2	0.062			
	Subtotal		0.57		0.2964	0.520		
<b>Total</b>			<b>0.660</b>		<b>0.339</b>	<b>0.51</b>		
<b>Overall Runoff Coefficient= C:</b>								

Total Roof Areas	0.000 ha
Total Tributary Surface Areas (Controlled and Uncontrolled)	0.660 ha
Total Tributary Area to Outlet	0.660 ha
 Total Uncontrolled Areas (Non-Tributary)	 0.000 ha
 Total Site	 0.660 ha



# Stormwater Management Calculations

**Project #160401668, 1300 MCWATTERS ROAD  
Modified Rational Method Calculators for Storage**

100 yr Intensity City of Ottawa	$I = a/(t + b)$	a =	1735.688	t (min)	I (mm/hr)
		b =	6.014	10	178.56
		c =	0.820	20	119.95
				30	91.87
			40	75.15	
			50	63.95	
			60	55.89	
			70	49.79	
			80	44.99	
			90	41.11	
			100	37.90	
			110	35.20	
			120	32.89	

**100 YEAR Modified Rational Method for Modified area in southern portion of site**

Subdrainage Area: Predevelopment Tributary Area to Outlet  
 Area (ha): 0.6600  
 C: 0.51

Existing conditions 100 year release rate

tc (min)	I (100 yr) (mm/hr)	Qtargt (L/s)
10	178.56	168.13

**100 YEAR Modified Rational Method for Modified area in southern portion of site**

Subdrainage Area: EX-3 Uncontrolled - Tributary  
 Area (ha): 0.09  
 C: 0.47

tc (min)	I (5 yr) (mm/hr)	Qactual (L/s)	Qrelease (L/s)	Qstored (L/s)	Vstored (m^3)
10	178.56	21.00	21.00		
20	119.95	14.11	14.11		
30	91.87	10.80	10.80		
40	75.15	8.84	8.84		
50	63.95	7.52	7.52		
60	55.89	6.57	6.57		
70	49.79	5.85	5.85		
80	44.99	5.29	5.29		
90	41.11	4.83	4.83		
100	37.90	4.46	4.46		
110	35.20	4.14	4.14		
120	32.89	3.87	3.87		

Subdrainage Area: EX-2 Uncontrolled - Tributary  
 Area (ha): 0.57  
 C: 0.52

tc (min)	I (5 yr) (mm/hr)	Qactual (L/s)	Qrelease (L/s)	Qstored (L/s)	Vstored (m^3)
10	178.56	147.13	147.13		
20	119.95	98.84	98.84		
30	91.87	75.70	75.70		
40	75.15	61.92	61.92		
50	63.95	52.70	52.70		
60	55.89	46.06	46.06		
70	49.79	41.03	41.03		
80	44.99	37.07	37.07		
90	41.11	33.88	33.88		
100	37.90	31.23	31.23		
110	35.20	29.01	29.01		
120	32.89	27.11	27.11		

**SUMMARY TO OUTLET**

			Vrequired	Vavailable*	
Tributary Area	0.660 ha				
Total 5yr Flow to Sewer	168 L/s	0		0 m <sup>3</sup>	Ok
Non-Tributary Area	0.000 ha				
Total 5yr Flow Uncontrolled	0 L/s				
Total Area	0.660 ha				
Total 5yr Flow Target	168 L/s				

**Project #160401668, 1300 MCWATTERS ROAD  
Modified Rational Method Calculators for Storage**

100 yr Intensity City of Ottawa	$I = a/(t + b)^c$	a =	1735.688	t (min)	I (mm/hr)
		b =	6.014	10	178.56
		c =	0.820	20	119.95
				30	91.87
			40	75.15	
			50	63.95	
			60	55.89	
			70	49.79	
			80	44.99	
			90	41.11	
			100	37.90	
			110	35.20	
			120	32.89	

**100 YEAR Predevelopment Target Release from Portion of Site**

Subdrainage Area: Predevelopment Tributary Area to Outlet  
 Area (ha): 0.6600  
 C: 0.51

Existing conditions 100 year release rate

tc (min)	I (100 yr) (mm/hr)	Q100yr (L/s)
10	178.56	168.13

**100 YEAR Modified Rational Method for Entire Site**

Subdrainage Area: POST-1 Uncontrolled - Tributary  
 Area (ha): 0.09  
 C: 0.68

tc (min)	I (100 yr) (mm/hr)	Qactual (L/s)	Qrelease (L/s)	Qstored (L/s)	Vstored (m^3)
10	178.56	30.38	30.38		
20	119.95	20.41	20.41		
30	91.87	15.63	15.63		
40	75.15	12.78	12.78		
50	63.95	10.88	10.88		
60	55.89	9.51	9.51		
70	49.79	8.47	8.47		
80	44.99	7.65	7.65		
90	41.11	6.99	6.99		
100	37.90	6.45	6.45		
110	35.20	5.99	5.99		
120	32.89	5.60	5.60		

Subdrainage Area: POST-2 Uncontrolled - Tributary  
 Area (ha): 0.57  
 C: 0.57

tc (min)	I (100 yr) (mm/hr)	Qactual (L/s)	Qrelease (L/s)	Qstored (L/s)	Vstored (m^3)
10	178.56	161.28	161.28		
20	119.95	108.34	108.34		
30	91.87	82.98	82.98		
40	75.15	67.87	67.87		
50	63.95	57.76	57.76		
60	55.89	50.49	50.49		
70	49.79	44.97	44.97		
80	44.99	40.64	40.64		
90	41.11	37.13	37.13		
100	37.90	34.23	34.23		
110	35.20	31.80	31.80		
120	32.89	29.71	29.71		

**SUMMARY TO OUTLET**

			Vrequired	Vavailable*	
Tributary Area	0.660 ha				
Total 100yr Flow to Sewer	192 L/s	14		15 m <sup>3</sup>	Ok
Non-Tributary Area	0.000 ha				
Total 100yr Flow Uncontrolled	0 L/s				
Total Area	0.660 ha				
Total 100yr Flow Target	192 L/s				

### **D.3 CORRESPONDENCE WITH RIDEAU VALLEY CONSERVATION AUTHORITY (RVCA)**



## Nwanise, Nwanise

---

**From:** Eric Lalande <eric.lalande@rvca.ca>  
**Sent:** Friday, May 21, 2021 2:20 PM  
**To:** Nwanise, Nwanise; Jamie Batchelor  
**Cc:** Gillis, Sheridan  
**Subject:** RE: 160401668 \_ 1300 & 1310 McWatters rd\_ stormwater quality control criteria

Hi Nwanise,

Base on the site design and location, the RVCA will required on-site enhanced water quality protection (80% TSS removal) to be provided. Further, best management practices to are encouraged including the implementation of LIDs where possible.

Thank you,

**Eric Lalande, MCIP, RPP**  
Planner, RVCA  
613-692-3571 x1137

---

**From:** Nwanise, Nwanise <Nwanise.Nwanise@stantec.com>  
**Sent:** Friday, May 21, 2021 11:27 AM  
**To:** Jamie Batchelor <jamie.batchelor@rvca.ca>  
**Cc:** Gillis, Sheridan <Sheridan.Gillis@stantec.com>; Eric Lalande <eric.lalande@rvca.ca>  
**Subject:** RE: 160401668 \_ 1300 & 1310 McWatters rd\_ stormwater quality control criteria

Thank you Jamie. We look forward to hearing back from Eric.

Eric please do not hesitate to reach out if you need clarify anything.

Have a nice long weekend.

Regards,

**Nwanise Nwanise**, EIT  
Engineering intern, Community Development

Direct: (647) 400-1759  
Mobile: (647) 400-1759  
[nwanise.nwanise@stantec.com](mailto:nwanise.nwanise@stantec.com)

Stantec  
400 - 1331 Clyde Avenue  
Ottawa ON K2C 3G4



**Better Together, Even If We're Apart.** [Read more](#) about Stantec's COVID-19 response, including remote working and business continuity measures.

The content of this email is the confidential property of Stantec and should not be copied, modified, retransmitted, or used for any purpose except with Stantec's written authorization. If you are not the intended recipient, please delete all copies and notify us immediately.

---

**From:** Jamie Batchelor <[jamie.batchelor@rvca.ca](mailto:jamie.batchelor@rvca.ca)>  
**Sent:** Friday, May 21, 2021 11:23 AM  
**To:** Nwanise, Nwanise <[Nwanise.Nwanise@stantec.com](mailto:Nwanise.Nwanise@stantec.com)>  
**Cc:** Gillis, Sheridan <[Sheridan.Gillis@stantec.com](mailto:Sheridan.Gillis@stantec.com)>; Eric Lalande <[eric.lalande@rvca.ca](mailto:eric.lalande@rvca.ca)>  
**Subject:** RE: 160401668 \_ 1300 & 1310 McWatters rd\_ stormwater quality control criteria

Good Morning Nwanise,

I'm forwarding your inquiry to my colleague Eric Lalande, as he would be the RVCA Planner for this area.

Jamie Batchelor, MCIP, RPP  
Planner, ext. 1191  
[Jamie.batchelor@rvca.ca](mailto:Jamie.batchelor@rvca.ca)



3889 Rideau Valley Drive  
PO Box 599, Manotick ON K4M 1A5  
T 613-692-3571 | 1-800-267-3504 F 613-692-0831 | [www.rvca.ca](http://www.rvca.ca)

This message may contain information that is privileged or confidential and is intended to be for the use of the individual(s) or entity you are not the intended recipient of this e-mail, any use, review, revision, retransmission, distribution, dissemination, copying, printing or taking of any action in reliance upon this e-mail, is strictly prohibited. If you have received this e-mail in error, please contact the sender and any copy of the e-mail and any printout thereof, immediately. Your cooperation is appreciated.

---

**From:** Nwanise, Nwanise <[Nwanise.Nwanise@stantec.com](mailto:Nwanise.Nwanise@stantec.com)>  
**Sent:** Wednesday, May 19, 2021 11:39 AM  
**To:** Jamie Batchelor <[jamie.batchelor@rvca.ca](mailto:jamie.batchelor@rvca.ca)>  
**Cc:** Gillis, Sheridan <[Sheridan.Gillis@stantec.com](mailto:Sheridan.Gillis@stantec.com)>  
**Subject:** 160401668 \_ 1300 & 1310 McWatters rd\_ stormwater quality control criteria

Good morning Jamie,

I hope you are keeping well.

I am writing you to request stormwater quality control criteria for a proposed development at 1300 & 1310 McWatters Road, the property area is bound by Lisa Avenue to the north, McWatters Road to the east, Baseline Road and commercial businesses to the south, and Greenbank road to the west. Stantec is preparing an adequacy of services report in support of a re-zoning application.

The proposed development area (0.68 ha) consists of a 25-storey residential high-rise building. The building is to contain a total of 235 units consisting of 97 one-bedroom units, 138 two-bedroom units with estimated population of 426, and approximately 1556 m<sup>2</sup> of communal amenity space. Internal circulation in the proposed development will be provided by access lanes for vehicles, surface parking for 29 vehicles, and two levels of underground parking with pedestrian access to the building.

A location map and FSR drainage plan are attached for your information.

Thank you for looking into this on our behalf, please do not hesitate to contact me if you require more information.

Regards,

**Nwanise Nwanise**, EIT  
Engineering intern, Community Development

Mobile: (647) 400-1759  
[nwanise.nwanise@stantec.com](mailto:nwanise.nwanise@stantec.com)

Stantec  
400 - 1331 Clyde Avenue  
Ottawa ON K2C 3G4



**Better Together, Even If We're Apart.** [Read more](#) about Stantec's COVID-19 response, including remote working and business continuity measures.

The content of this email is the confidential property of Stantec and should not be copied, modified, retransmitted, or used for any purpose except with Stantec's written authorization. If you are not the intended recipient, please delete all copies and notify us immediately.

## **D.4 OIL-GRIT SEPERATOR DESIGN SHEET**



Stormceptor® EF Sizing Report

**STORMCEPTOR®**

**ESTIMATED NET ANNUAL SEDIMENT (TSS) LOAD REDUCTION**

02/24/2022

Province:	Ontario
City:	Ottawa
Nearest Rainfall Station:	OTTAWA CDA RCS
Climate Station Id:	6105978
Years of Rainfall Data:	20

Site Name:	1300 McWatters Road
------------	---------------------

Drainage Area (ha):	0.64
---------------------	------

Runoff Coefficient 'c':	0.64
-------------------------	------

Particle Size Distribution:	Fine
-----------------------------	------

Target TSS Removal (%):	80.0
-------------------------	------

Required Water Quality Runoff Volume Capture (%):	90.00
---	-------

Estimated Water Quality Flow Rate (L/s):	13.89
--	-------

Oil / Fuel Spill Risk Site?	Yes
-----------------------------	-----

Upstream Flow Control?	Yes
------------------------	-----

Upstream Orifice Control Flow Rate to Stormceptor (L/s):	59.00
--	-------

Peak Conveyance (maximum) Flow Rate (L/s):	59.00
--	-------

Site Sediment Transport Rate (kg/ha/yr):	
--	--

Project Name:	1300 McWatters Road
---------------	---------------------

Project Number:	160401668
-----------------	-----------

Designer Name:	Nwanise Nwanise
----------------	-----------------

Designer Company:	Stantec Consulting Ltd
-------------------	------------------------

Designer Email:	nwanise.nwanise@stantec.com
-----------------	-----------------------------

Designer Phone:	647-400-1759
-----------------	--------------

EOR Name:	Karin Smadella
-----------	----------------

EOR Company:	Stantec Consulting Ltd
--------------	------------------------

EOR Email:	karin.smadella@stantec.com
------------	----------------------------

EOR Phone:	613-724-4371
------------	--------------

**Net Annual Sediment (TSS) Load Reduction Sizing Summary**

Stormceptor Model	TSS Removal Provided (%)
EFO4	79
<b>EFO6</b>	<b>89</b>
EFO8	94
EFO10	97
EFO12	99

**Recommended Stormceptor EFO Model: EFO6**

**Estimated Net Annual Sediment (TSS) Load Reduction (%): 89**

**Water Quality Runoff Volume Capture (%): > 90**



## Stormceptor® EF Sizing Report

### THIRD-PARTY TESTING AND VERIFICATION

► **Stormceptor® EF and Stormceptor® EFO** are the latest evolutions in the Stormceptor® oil-grit separator (OGS) technology series, and are designed to remove a wide variety of pollutants from stormwater and snowmelt runoff. These technologies have been third-party tested in accordance with the Canadian ETV **Procedure for Laboratory Testing of Oil-Grit Separators** and performance has been third-party verified in accordance with the **ISO 14034 Environmental Technology Verification (ETV)** protocol.

### PERFORMANCE

► **Stormceptor® EF and EFO** remove stormwater pollutants through gravity separation and floatation, and feature a patent-pending design that generates positive removal of total suspended solids (TSS) throughout each storm event, including high-intensity storms. Captured pollutants include sediment, free oils, and sediment-bound pollutants such as nutrients, heavy metals, and petroleum hydrocarbons. Stormceptor is sized to remove a high level of TSS from the frequent rainfall events that contribute the vast majority of annual runoff volume and pollutant load. The technology incorporates an internal bypass to convey excessive stormwater flows from high-intensity storms through the device without resuspension and washout (scour) of previously captured pollutants. Proper routine maintenance ensures high pollutant removal performance and protection of downstream waterways.

### PARTICLE SIZE DISTRIBUTION (PSD)

► The **Canadian ETV PSD** shown in the table below was used, or in part, for this sizing. This is the identical PSD that is referenced in the Canadian ETV **Procedure for Laboratory Testing of Oil-Grit Separators** for both sediment removal testing and scour testing. The Canadian ETV PSD contains a wide range of particle sizes in the sand and silt fractions, and is considered reasonably representative of the particle size fractions found in typical urban stormwater runoff.

Particle Size (µm)	Percent Less Than	Particle Size Fraction (µm)	Percent
1000	100	500-1000	5
500	95	250-500	5
250	90	150-250	15
150	75	100-150	15
100	60	75-100	10
75	50	50-75	5
50	45	20-50	10
20	35	8-20	15
8	20	5-8	10
5	10	2-5	5
2	5	<2	5



Stormceptor® EF Sizing Report

Upstream Flow Controlled Results

Rainfall Intensity (mm / hr)	Percent Rainfall Volume (%)	Cumulative Rainfall Volume (%)	Flow Rate (L/s)	Flow Rate (L/min)	Surface Loading Rate (L/min/m <sup>2</sup> )	Removal Efficiency (%)	Incremental Removal (%)	Cumulative Removal (%)
1	22.3	22.3	1.14	68.0	26.0	100	22.3	22.3
2	17.8	40.0	2.28	137.0	52.0	98	17.4	39.7
3	13.1	53.1	3.42	205.0	78.0	94	12.3	52.0
4	9.2	62.4	4.55	273.0	104.0	89	8.2	60.2
5	6.5	68.9	5.69	342.0	130.0	85	5.6	65.8
6	5.1	74.0	6.83	410.0	156.0	83	4.2	70.0
7	3.4	77.3	7.97	478.0	182.0	80	2.7	72.7
8	3.0	80.3	9.11	547.0	208.0	77	2.3	75.0
9	3.6	84.0	10.25	615.0	234.0	76	2.8	77.8
10	2.5	86.5	11.39	683.0	260.0	75	1.9	79.6
11	1.7	88.2	12.53	752.0	286.0	74	1.3	80.9
12	1.4	89.6	13.66	820.0	312.0	72	1.0	81.9
13	1.9	91.5	14.80	888.0	338.0	72	1.4	83.3
14	1.3	92.8	15.94	956.0	364.0	70	0.9	84.2
15	1.3	94.1	17.08	1025.0	390.0	69	0.9	85.1
16	0.8	94.9	18.22	1093.0	416.0	68	0.5	85.6
17	0.8	95.7	19.36	1161.0	442.0	67	0.5	86.2
18	0.4	96.1	20.50	1230.0	468.0	66	0.3	86.5
19	0.5	96.6	21.64	1298.0	494.0	65	0.3	86.7
20	0.2	96.8	22.77	1366.0	520.0	63	0.2	86.9
21	0.5	97.3	23.91	1435.0	546.0	63	0.3	87.2
22	0.3	97.6	25.05	1503.0	572.0	61	0.2	87.4
23	1.1	98.7	26.19	1571.0	597.0	60	0.7	88.0
24	0.3	99.0	27.33	1640.0	623.0	60	0.2	88.2
25	1.0	100.0	28.47	1708.0	649.0	60	0.6	88.8
30	1.0	101.0	34.16	2050.0	779.0	59	0.6	89.4
35	-1.0	100.0	39.85	2391.0	909.0	58	N/A	88.8
40	0.0	100.0	45.55	2733.0	1039.0	56	0.0	88.8
45	0.0	100.0	51.24	3074.0	1169.0	54	0.0	88.8
50	0.0	100.0	56.93	3416.0	1299.0	51	0.0	88.8
<b>Estimated Net Annual Sediment (TSS) Load Reduction =</b>								<b>89 %</b>

Climate Station ID: 6105978 Years of Rainfall Data: 20



Stormceptor® **EF** Sizing Report

**RAINFALL DATA FROM OTTAWA CDA RCS RAINFALL STATION**

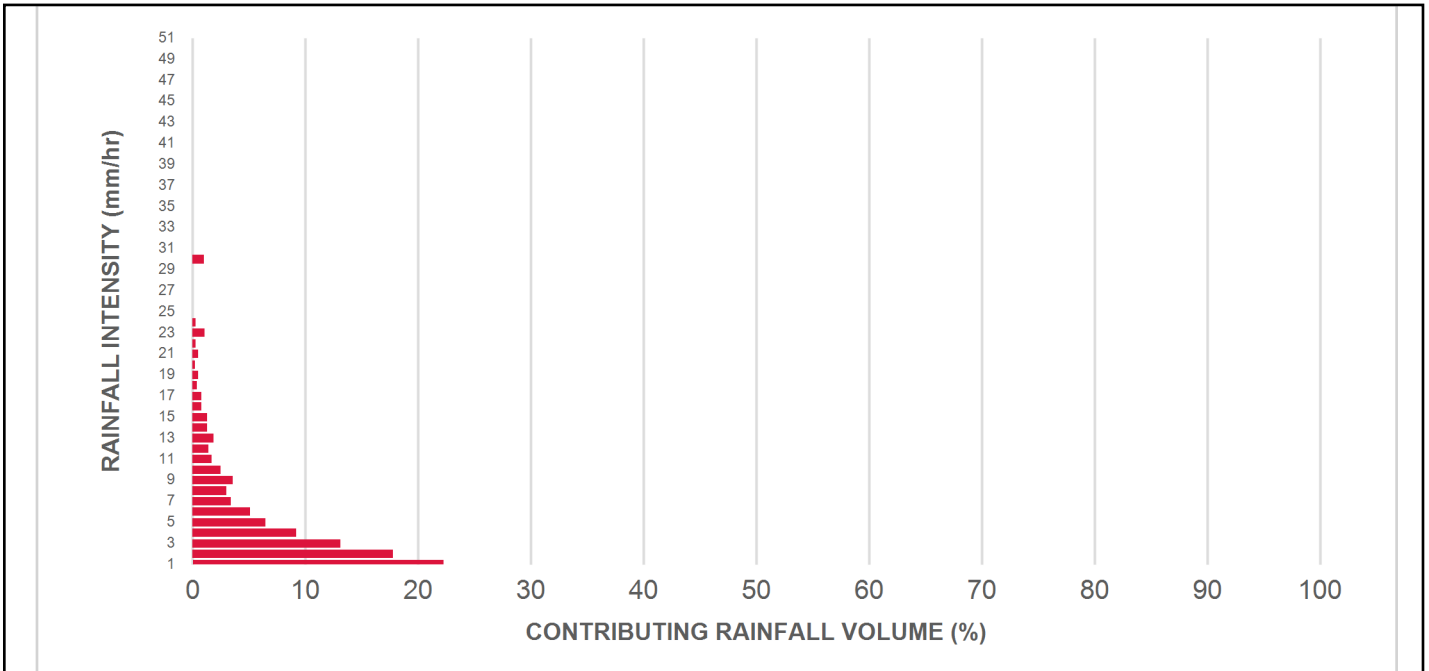

**INCREMENTAL AND CUMULATIVE TSS REMOVAL FOR THE RECOMMENDED STORMCEPTOR® MODEL**

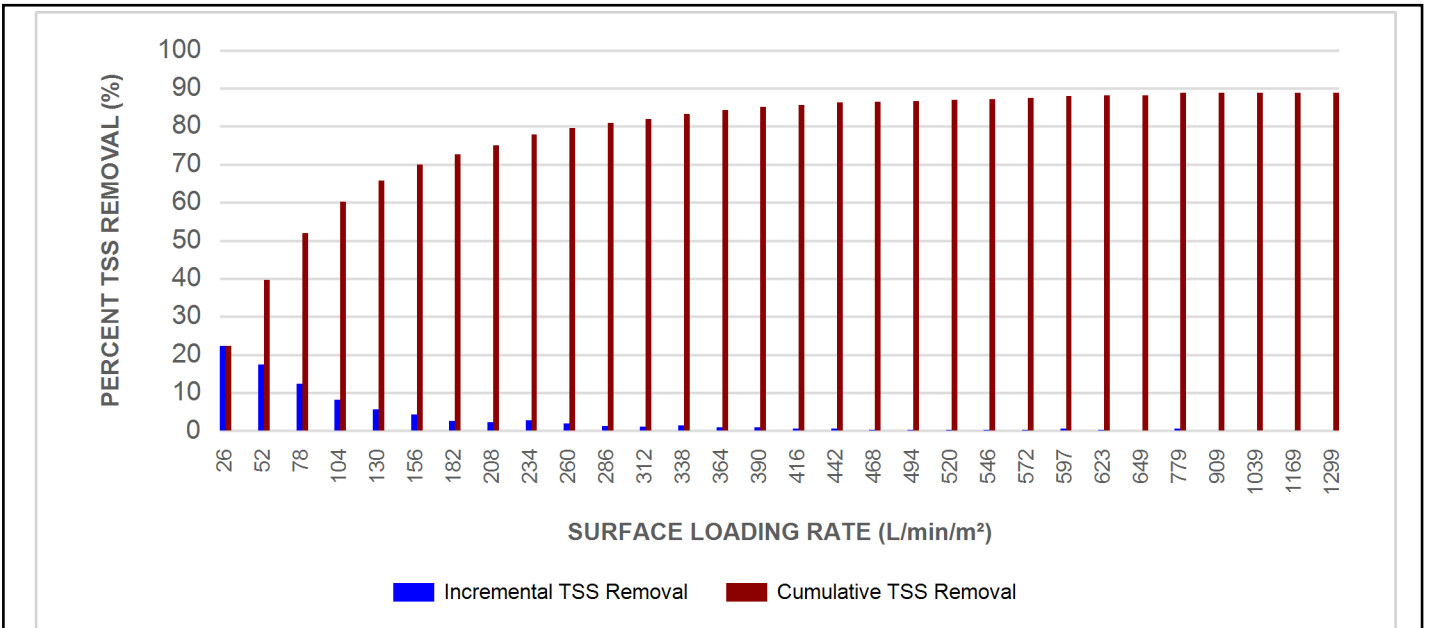

Stormceptor® **EF** Sizing Report

Maximum Pipe Diameter / Peak Conveyance

Stormceptor EF / EFO	Model Diameter		Min Angle Inlet / Outlet Pipes	Max Inlet Pipe Diameter		Max Outlet Pipe Diameter		Peak Conveyance Flow Rate	
	(m)	(ft)		(mm)	(in)	(mm)	(in)	(L/s)	(cfs)
EF4 / EFO4	1.2	4	90	609	24	609	24	425	15
EF6 / EFO6	1.8	6	90	914	36	914	36	990	35
EF8 / EFO8	2.4	8	90	1219	48	1219	48	1700	60
EF10 / EFO10	3.0	10	90	1828	72	1828	72	2830	100
EF12 / EFO12	3.6	12	90	1828	72	1828	72	2830	100

**SCOUR PREVENTION AND ONLINE CONFIGURATION**

► Stormceptor® EF and EFO feature an internal bypass and superior scour prevention technology that have been demonstrated in third-party testing according to the scour testing provisions of the Canadian ETV **Procedure for Laboratory Testing of Oil-Grit Separators**, and the exceptional scour test performance has been third-party verified in accordance with the ISO 14034 ETV protocol. As a result, Stormceptor EF and EFO are approved for online installation, eliminating the need for costly additional bypass structures, piping, and installation expense.

**DESIGN FLEXIBILITY**

► Stormceptor® EF and EFO offers design flexibility in one simplified platform, accepting stormwater flow from a single inlet pipe or multiple inlet pipes, and/or surface runoff through an inlet grate. The device can also serve as a junction structure, accommodate a 90-degree inlet-to-outlet bend angle, and can be modified to ensure performance in submerged conditions.

**OIL CAPTURE AND RETENTION**

► While Stormceptor® EF will capture and retain oil from dry weather spills and low intensity runoff, Stormceptor® EFO has demonstrated superior oil capture and greater than 99% oil retention in third-party testing according to the light liquid re-entrainment testing provisions of the Canadian ETV **Procedure for Laboratory Testing of Oil-Grit Separators**. Stormceptor EFO is recommended for sites where oil capture and retention is a requirement.

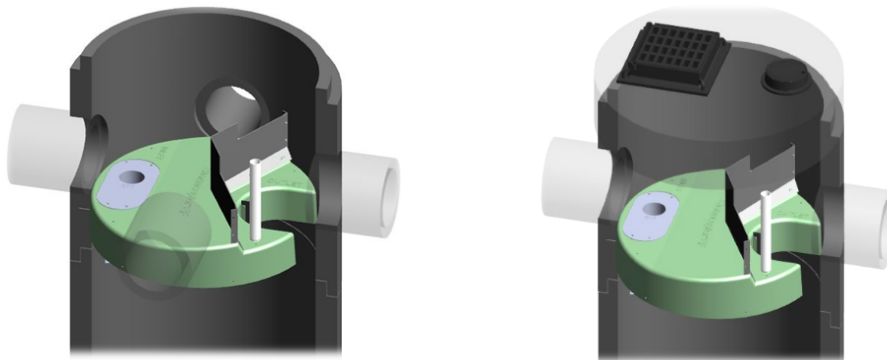

## Stormceptor® EF Sizing Report

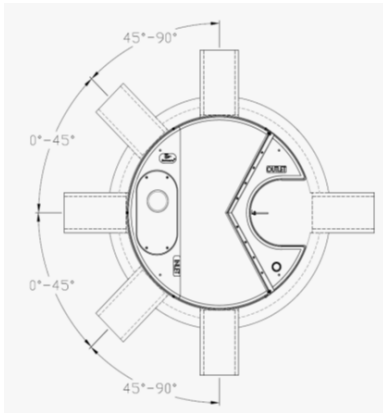

### INLET-TO-OUTLET DROP

Elevation differential between inlet and outlet pipe inverts is dictated by the angle at which the inlet pipe(s) enters the unit.

0° - 45° : The inlet pipe is 1-inch (25mm) higher than the outlet pipe.

45° - 90° : The inlet pipe is 2-inches (50mm) higher than the outlet pipe.

### HEAD LOSS

The head loss through Stormceptor EF is similar to that of a 60-degree bend structure. The applicable K value for calculating minor losses through the unit is 1.1.

For submerged conditions the applicable K value is 3.0.

### Pollutant Capacity

Stormceptor EF / EFO	Model Diameter		Depth (Outlet Pipe Invert to Sump Floor)		Oil Volume		Recommended Sediment Maintenance Depth *		Maximum Sediment Volume *		Maximum Sediment Mass **	
	(m)	(ft)	(m)	(ft)	(L)	(Gal)	(mm)	(in)	(L)	(ft³)	(kg)	(lb)
EF4 / EFO4	1.2	4	1.52	5.0	265	70	203	8	1190	42	1904	5250
EF6 / EFO6	1.8	6	1.93	6.3	610	160	305	12	3470	123	5552	15375
EF8 / EFO8	2.4	8	2.59	8.5	1070	280	610	24	8780	310	14048	38750
EF10 / EFO10	3.0	10	3.25	10.7	1670	440	610	24	17790	628	28464	78500
EF12 / EFO12	3.6	12	3.89	12.8	2475	655	610	24	31220	1103	49952	137875

\*Increased sump depth may be added to increase sediment storage capacity

\*\* Average density of wet packed sediment in sump = 1.6 kg/L (100 lb/ft³ )

Feature	Benefit	Feature Appeals To
Patent-pending enhanced flow treatment and scour prevention technology	Superior, verified third-party performance	Regulator, Specifying & Design Engineer
Third-party verified light liquid capture and retention for EFO version	Proven performance for fuel/oil hotspot locations	Regulator, Specifying & Design Engineer, Site Owner
Functions as bend, junction or inlet structure	Design flexibility	Specifying & Design Engineer
Minimal drop between inlet and outlet	Site installation ease	Contractor
Large diameter outlet riser for inspection and maintenance	Easy maintenance access from grade	Maintenance Contractor & Site Owner

### STANDARD STORMCEPTOR EF/EFO DRAWINGS

For standard details, please visit <http://www.imbriumsystems.com/stormwater-treatment-solutions/stormceptor-ef>

### STANDARD STORMCEPTOR EF/EFO SPECIFICATION

For specifications, please visit <http://www.imbriumsystems.com/stormwater-treatment-solutions/stormceptor-ef>

Stormceptor® **EF** Sizing Report

**STANDARD PERFORMANCE SPECIFICATION FOR  
“OIL GRIT SEPARATOR” (OGS) STORMWATER QUALITY TREATMENT DEVICE**

**PART 1 – GENERAL**

1.1 WORK INCLUDED

This section specifies requirements for selecting, sizing, and designing an underground Oil Grit Separator (OGS) device for stormwater quality treatment, with third-party testing results and a Statement of Verification in accordance with ISO 14034 Environmental Management – Environmental Technology Verification (ETV).

1.2 REFERENCE STANDARDS & PROCEDURES

ISO 14034:2016 Environmental management – Environmental technology verification (ETV)

Canadian Environmental Technology Verification (ETV) Program’s **Procedure for Laboratory Testing of Oil-Grit Separators**

1.3 SUBMITTALS

1.3.1 All submittals, including sizing reports & shop drawings, shall be submitted upon request with each order to the contractor then forwarded to the Engineer of Record for review and acceptance. Shop drawings shall detail all OGS components, elevations, and sequence of construction.

1.3.2 Alternative devices shall have features identical to or greater than the specified device, including: treatment chamber diameter, treatment chamber wet volume, sediment storage volume, and oil storage volume.

1.3.3 Unless directed otherwise by the Engineer of Record, OGS stormwater quality treatment product substitutions or alternatives submitted within ten days prior to project bid shall not be accepted. All alternatives or substitutions submitted shall be signed and sealed by a local registered Professional Engineer, based on the exact same criteria detailed in Section 3, in entirety, subject to review and approval by the Engineer of Record.

**PART 2 – PRODUCTS**

2.1 OGS POLLUTANT STORAGE

The OGS device shall include a sump for sediment storage, and a protected volume for the capture and storage of petroleum hydrocarbons and buoyant gross pollutants. The minimum sediment & petroleum hydrocarbon storage capacity shall be as follows:

2.1.1	4 ft (1219 mm) Diameter OGS Units:	1.19 m <sup>3</sup> sediment / 265 L oil
	6 ft (1829 mm) Diameter OGS Units:	3.48 m <sup>3</sup> sediment / 609 L oil
	8 ft (2438 mm) Diameter OGS Units:	8.78 m <sup>3</sup> sediment / 1,071 L oil
	10 ft (3048 mm) Diameter OGS Units:	17.78 m <sup>3</sup> sediment / 1,673 L oil
	12 ft (3657 mm) Diameter OGS Units:	31.23 m <sup>3</sup> sediment / 2,476 L oil

**PART 3 – PERFORMANCE & DESIGN**

3.1 GENERAL

The OGS stormwater quality treatment device shall be verified in accordance with ISO 14034:2016 Environmental management – Environmental technology verification (ETV). The OGS stormwater quality treatment device shall



## Stormceptor® EF Sizing Report

remove oil, sediment and gross pollutants from stormwater runoff during frequent wet weather events, and retain these pollutants during less frequent high flow wet weather events below the insert within the OGS for later removal during maintenance. The Manufacturer shall have at least ten (10) years of local experience, history and success in engineering design, manufacturing and production and supply of OGS stormwater quality treatment device systems, acceptable to the Engineer of Record.

### 3.2 SIZING METHODOLOGY

The OGS device shall be engineered, designed and sized to provide stormwater quality treatment based on treating a minimum of 90 percent of the average annual runoff volume and a minimum removal of an annual average 60% of the sediment (TSS) load based on the Particle Size Distribution (PSD) specified in the sizing report for the specified device. Sizing of the OGS shall be determined by use of a minimum ten (10) years of local historical rainfall data provided by Environment Canada, and only rainfall intensities greater than 0.5 mm/hr shall be included in sizing calculations. Sizing shall also be determined by use of the sediment removal performance data derived from the ISO 14034 ETV third-party verified laboratory testing data from testing conducted in accordance with the Canadian ETV protocol Procedure for Laboratory Testing of Oil-Grit Separators, as follows:

3.2.1 Sediment removal efficiency for a given surface loading rate and its associated flow rate shall be based on sediment removal efficiency demonstrated at the seven (7) tested surface loading rates specified in the protocol, ranging 40 L/min/m<sup>2</sup> to 1400 L/min/m<sup>2</sup>, and as stated in the ISO 14034 ETV Verification Statement for the OGS device.

3.2.2 Sediment removal efficiency for surface loading rates between 40 L/min/m<sup>2</sup> and 1400 L/min/m<sup>2</sup> shall be based on linear interpolation of data between consecutive tested surface loading rates.

3.2.3 Sediment removal efficiency for surface loading rates less than the lowest tested surface loading rate of 40 L/min/m<sup>2</sup> shall be assumed to be identical to the sediment removal efficiency at 40 L/min/m<sup>2</sup>. No extrapolation shall be allowed that results in a sediment removal efficiency that is greater than that demonstrated at 40 L/min/m<sup>2</sup>.

3.2.4 Sediment removal efficiency for surface loading rates greater than the highest tested surface loading rate of 1400 L/min/m<sup>2</sup> shall assume zero sediment removal for the portion of flow that exceeds 1400 L/min/m<sup>2</sup>, and shall be calculated using a simple proportioning formula, with 1400 L/min/m<sup>2</sup> in the numerator and the higher surface loading rate in the denominator, and multiplying the resulting fraction times the sediment removal efficiency at 1400 L/min/m<sup>2</sup>.

The OGS device shall also have sufficient annual sediment storage capacity as specified and calculated in Section 2.1.

### 3.3 CANADIAN ETV or ISO 14034 ETV VERIFICATION OF SCOUR TESTING

The OGS device shall have Canadian ETV or ISO 14034 ETV Verification of third-party scour testing conducted in accordance with the Canadian ETV Program's **Procedure for Laboratory Testing of Oil-Grit Separators**.

3.3.1 To be acceptable for on-line installation, the OGS device must demonstrate an average scour test effluent concentration less than 10 mg/L at each surface loading rate tested, up to and including 2600 L/min/m<sup>2</sup>.

### 3.4 LIGHT LIQUID RE-ENTRAINMENT SIMULATION TESTING

The OGS device shall have Canadian ETV or ISO 14034 ETV Verification of completed third-party Light Liquid Re-entrainment Simulation Testing in accordance with the Canadian ETV **Program's Procedure for Laboratory Testing of Oil-Grit Separators**, with results reported within the Canadian ETV or ISO 14034 ETV verification. This re-entrainment testing is conducted with the device pre-loaded with low density polyethylene (LDPE) plastic beads as a

## Stormceptor® EF Sizing Report

surrogate for light liquids such as oil and fuel. Testing is conducted on the same OGS unit tested for sediment removal to assess whether light liquids captured after a spill are effectively retained at high flow rates.

3.4.1 For an OGS device to be an acceptable stormwater treatment device on a site where vehicular traffic occurs and the potential for an oil or fuel spill exists, the OGS device must have reported verified performance results of greater than 99% cumulative retention of LDPE plastic beads for the five specified surface loading rates (ranging 200 L/min/m<sup>2</sup> to 2600 L/min/m<sup>2</sup>) in accordance with the Light Liquid Re-entrainment Simulation Testing within the Canadian ETV Program's **Procedure for Laboratory Testing of Oil-Grit Separators**. However, an OGS device shall not be allowed if the Light Liquid Re-entrainment Simulation Testing was performed with screening components within the OGS device that are effective at retaining the LDPE plastic beads, but would not be expected to retain light liquids such as oil and fuel.

# DRAWING NOT TO BE USED FOR CONSTRUCTION

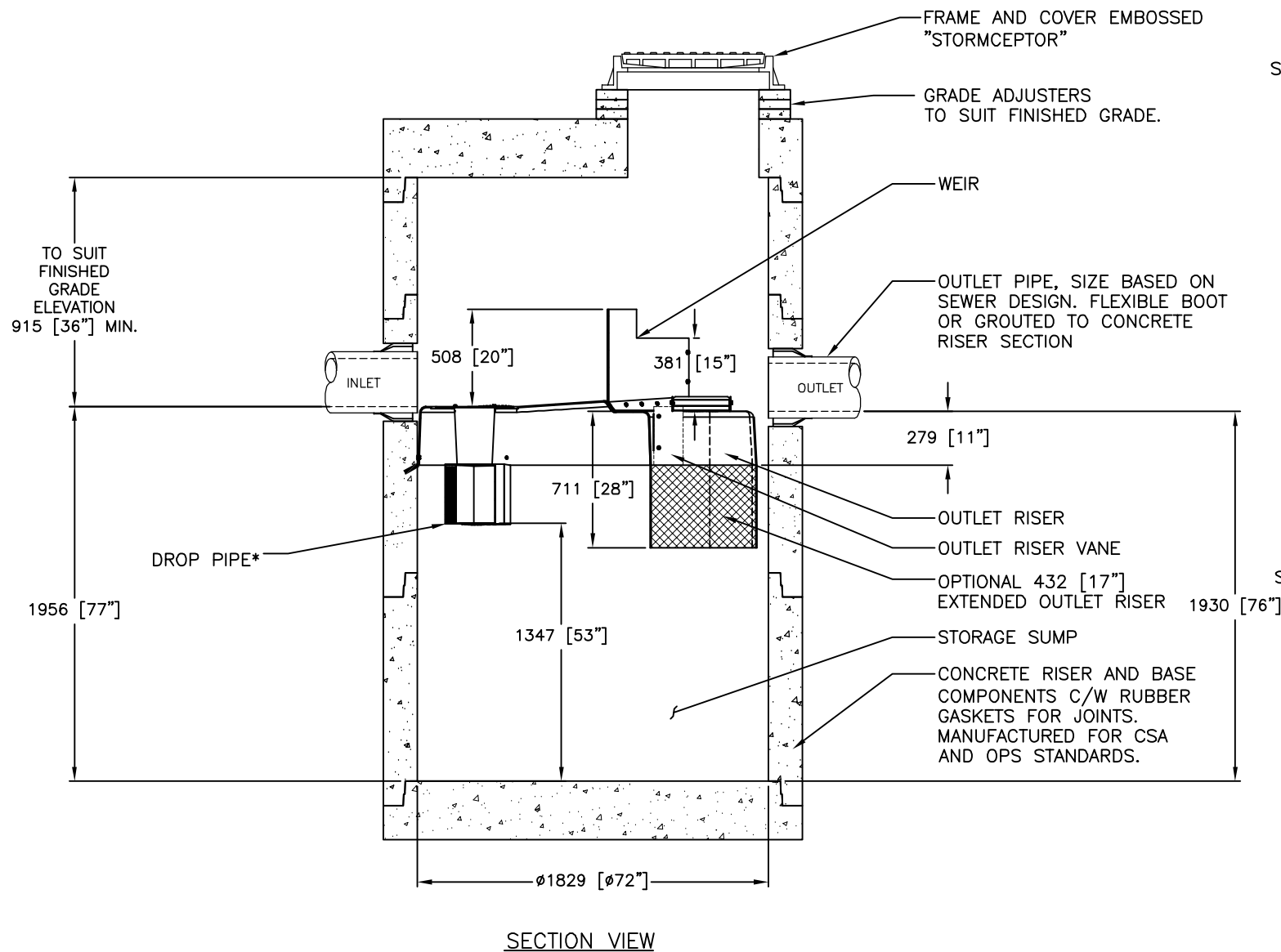

SECTION VIEW

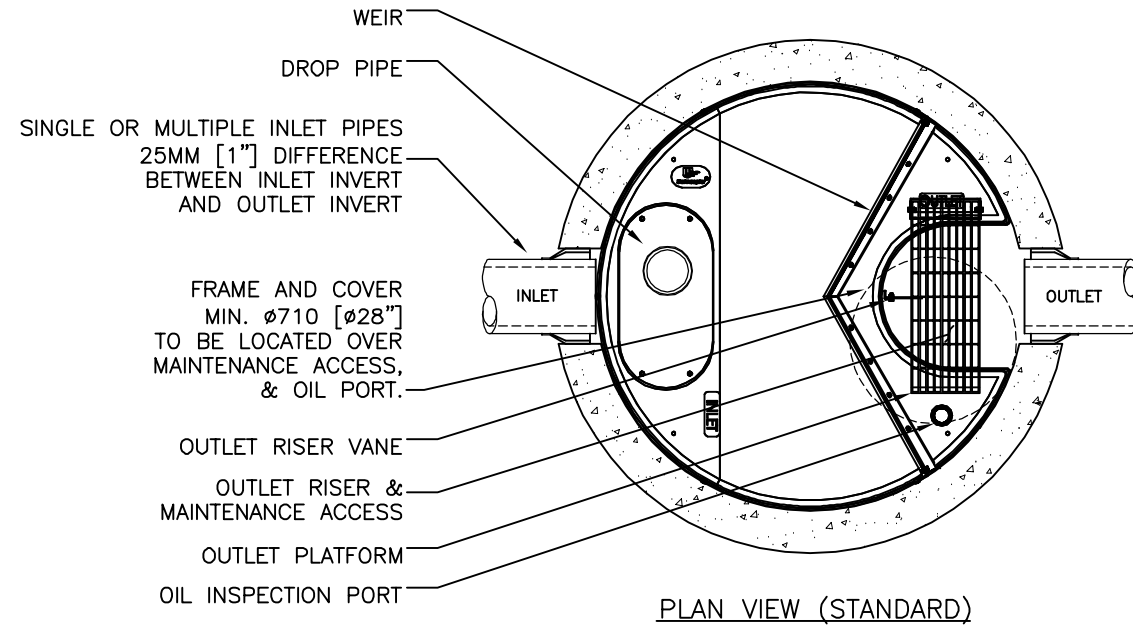

PLAN VIEW (STANDARD)

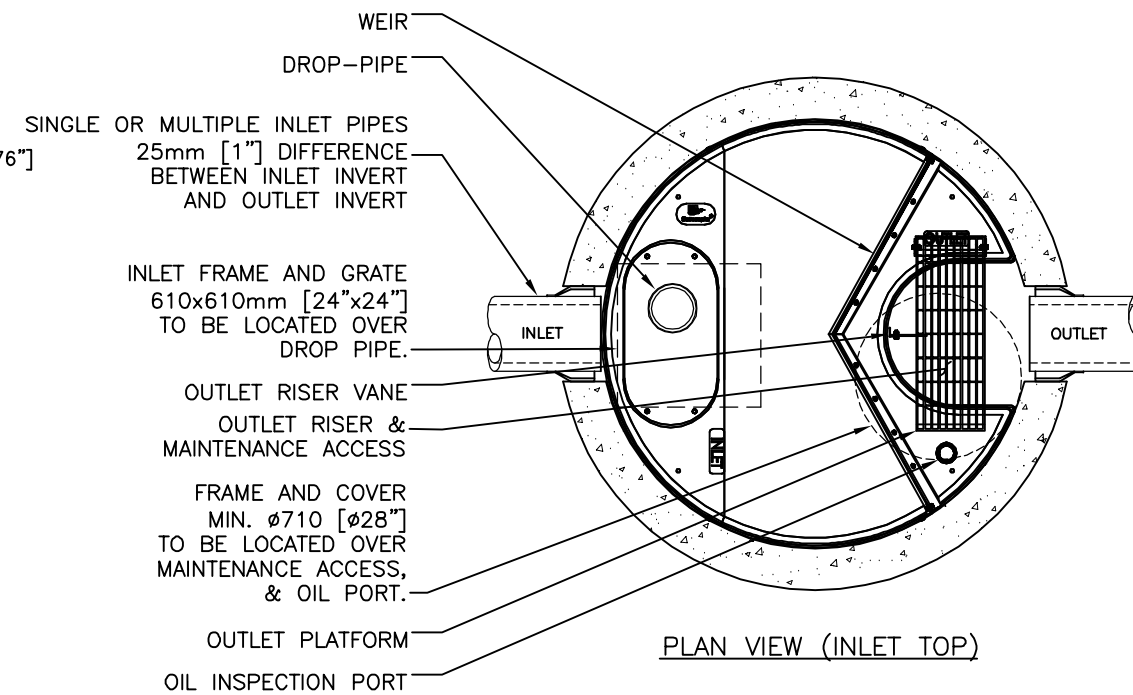

PLAN VIEW (INLET TOP)

**GENERAL NOTES:**

- \* MAXIMUM SURFACE LOADING RATE (SLR) INTO LOWER CHAMBER THROUGH DROP PIPE IS 1135 L/min/m<sup>2</sup> (27.9 gpm/ft<sup>2</sup>) FOR STORMCEPTOR EF6 AND 535 L/min/m<sup>2</sup> (13.1 gpm/ft<sup>2</sup>) FOR STORMCEPTOR EFO6 (OIL CAPTURE CONFIGURATION).
- 1. ALL DIMENSIONS INDICATED ARE IN MILLIMETERS (INCHES) UNLESS OTHERWISE SPECIFIED.
- 2. STORMCEPTOR STRUCTURE INLET AND OUTLET PIPE SIZE AND ORIENTATION SHOWN FOR INFORMATIONAL PURPOSES ONLY.
- 3. UNLESS OTHERWISE NOTED, BYPASS INFRASTRUCTURE, SUCH AS ALL UPSTREAM DIVERSION STRUCTURES, CONNECTING STRUCTURES, OR PIPE CONDUITS CONNECTING TO COMPLETE THE STORMCEPTOR SYSTEM SHALL BE PROVIDED AND ADDRESSED SEPARATELY.
- 4. DRAWING FOR INFORMATION PURPOSES ONLY. REFER TO ENGINEER'S SITE/UTILITY PLAN FOR STRUCTURE ORIENTATION.
- 5. NO PRODUCT SUBSTITUTIONS SHALL BE ACCEPTED UNLESS SUBMITTED 10 DAYS PRIOR TO PROJECT BID DATE, OR AS DIRECTED BY THE ENGINEER OF RECORD.

**INSTALLATION NOTES**

- A. ANY SUB-BASE, BACKFILL DEPTH, AND/OR ANTI-FLOTATION PROVISIONS ARE SITE-SPECIFIC DESIGN CONSIDERATIONS AND SHALL BE SPECIFIED BY ENGINEER OF RECORD.
- B. CONTRACTOR TO PROVIDE EQUIPMENT WITH SUFFICIENT LIFTING AND REACH CAPACITY TO LIFT AND SET THE STRUCTURE (LIFTING CLUTCHES PROVIDED)
- C. CONTRACTOR WILL INSTALL AND LEVEL THE STRUCTURE, SEALING THE JOINTS, LINE ENTRY AND EXIT POINTS (NON-SHRINK GROUT WITH APPROVED WATERSTOP OR FLEXIBLE BOOT)
- D. CONTRACTOR TO TAKE APPROPRIATE MEASURES TO PROTECT THE DEVICE FROM CONSTRUCTION-RELATED EROSION RUNOFF.
- E. DEVICE ACTIVATION, BY CONTRACTOR, SHALL OCCUR ONLY AFTER SITE HAS BEEN STABILIZED AND THE STORMCEPTOR UNIT IS CLEAN AND FREE OF DEBRIS.

FOR SITE SPECIFIC DRAWINGS PLEASE CONTACT YOUR LOCAL STORMCEPTOR REPRESENTATIVE. SITE SPECIFIC DRAWINGS ARE BASED ON THE BEST AVAILABLE INFORMATION AT THE TIME. SOME FIELD REVISIONS TO THE SYSTEM LOCATION OR CONNECTION PIPING MAY BE NECESSARY BASED ON AVAILABLE SPACE OR SITE CONFIGURATION REVISIONS. ELEVATIONS SHOULD BE MAINTAINED EXCEPT WHERE NOTED ON BYPASS STRUCTURE (IF REQUIRED).

## STANDARD DETAIL NOT FOR CONSTRUCTION

SITE SPECIFIC DATA REQUIREMENTS					
STORMCEPTOR MODEL	EFO6				
STRUCTURE ID	*				
HYDROCARBON STORAGE REQ'D (L)	*				
WATER QUALITY FLOW RATE (L/s)	*				
PEAK FLOW RATE (L/s)	*				
RETURN PERIOD OF PEAK FLOW (yrs)	*				
DRAINAGE AREA (HA)	*				
DRAINAGE AREA IMPERVIOUSNESS (%)	*				
PIPE DATA:	I.E.	MAT'L	DIA	SLOPE %	HGL
INLET #1	*	*	*	*	*
INLET #2	*	*	*	*	*
OUTLET	*	*	*	*	*
* PER ENGINEER OF RECORD					

This drawing and information shown on this drawing is provided as a service to the project owner, engineer and contractor by Imbrium Systems ("Imbrium"). Neither the drawing, nor any part thereof, may be reproduced, stored in a retrieval system, or transmitted in any form or by any means, electronic, mechanical, photocopying, recording, or by any information storage and retrieval system, without the prior written consent of Imbrium. It is to be used only for the project and site for which it is prepared and Imbrium expressly disclaims any liability or responsibility for such use. If discrepancies between the supplied information upon which this drawing is based and actual field conditions are discovered, the contractor shall be responsible for re-evaluation of the design. Imbrium accepts no liability for designs based on missing, incomplete or inaccurate information supplied by others.

MARK	DATE	REVISION DESCRIPTION	BY
###	###/###/###	OUTLET PLATFORM	JSK
###	###/###/###	INITIAL RELEASE	JSK

407 FAIRVIEW DRIVE, WHITBY, ON L1N 3J9  
 TEL: 905-565-4801 CA 416-960-9800 INTL +1-416-960-9800  
 THE ENGINEER'S RESPONSIBILITY IS TO PROVIDE YOU WITH THE BEST AVAILABLE INFORMATION AT THE TIME. SOME FIELD REVISIONS TO THE SYSTEM LOCATION OR CONNECTION PIPING MAY BE NECESSARY BASED ON AVAILABLE SPACE OR SITE CONFIGURATION REVISIONS. ELEVATIONS SHOULD BE MAINTAINED EXCEPT WHERE NOTED ON BYPASS STRUCTURE (IF REQUIRED).

DATE:	10/13/2017	
DESIGNED:	JSK	DRAWN:
CHECKED:	BSF	APPROVED:
PROJECT No.:	EFO6	SEQUENCE No.:
SHEET:	1 OF 1	



## **D.5 STORM SEWER DESIGN SHEET**





## Appendix E EXTERNAL REPORTS

### E.1 GEOTECHNICAL INVESTIGATION (PATERSON, 2021)



Geotechnical  
Engineering

Environmental  
Engineering

Hydrogeology

Geological  
Engineering

Materials Testing

Building Science

Vibration and Noise Studies

## Geotechnical Investigation

Proposed Multi-Storey Building  
1300-1310 McWatters Road  
Ottawa, Ontario

Prepared For

Homestead Land Holdings Inc.

### Paterson Group Inc.

Consulting Engineers  
154 Colonnade Road South  
Ottawa (Nepean), Ontario  
Canada K2E 7J5

Tel: (613) 226-7381  
Fax: (613) 226-6344  
[www.patersongroup.ca](http://www.patersongroup.ca)

May 26, 2021

Report: PG5729-1

## Table of Contents

	<b>Page</b>
<b>1.0 Introduction</b> .....	1
<b>2.0 Proposed Development</b> .....	1
<b>3.0 Method of Investigation</b>	
3.1 Field Investigation .....	2
3.2 Field Survey .....	3
3.3 Laboratory Testing .....	3
3.4 Analytical Testing .....	3
<b>4.0 Observations</b>	
4.1 Surface Conditions .....	4
4.2 Subsurface Profile .....	4
4.3 Groundwater .....	5
<b>5.0 Discussion</b>	
5.1 Geotechnical Assessment .....	6
5.2 Site Grading and Preparation .....	6
5.3 Foundation Design .....	7
5.4 Design for Earthquakes .....	8
5.5 Basement Floor Slab .....	9
5.6 Basement Wall .....	9
5.7 Pavement Structure .....	11
<b>6.0 Design and Construction Precautions</b>	
6.1 Foundation Drainage and Backfill .....	13
6.2 Protection of Footings Against Frost Action .....	14
6.3 Excavation Side Slopes .....	14
6.4 Pipe Bedding and Backfill .....	16
6.5 Groundwater Control .....	17
6.6 Winter Construction .....	18
6.7 Corrosion Potential and Sulphate .....	18
<b>7.0 Recommendations</b> .....	19
<b>8.0 Statement of Limitations</b> .....	20

## **Appendices**

- Appendix 1    Soil Profile and Test Data Sheets
  - Symbols and Terms
  - Analytical Testing Results
  
- Appendix 2    Figure 1 - Key Plan
  - Figure 2 - Aerial Photograph - 1965
  - Figure 3 - Aerial Photograph - 2019
  - Drawing PG5729-1 - Test Hole Location Plan

## 1.0 Introduction

Paterson Group (Paterson) was commissioned by Homestead Land Holdings Ltd. to conduct a geotechnical investigation for the proposed multi-storey building to be located at 1300-1310 McWatters Road, in the City of Ottawa, Ontario (refer to Figure 1 - Key Plan in Appendix 2 of this report).

The objectives of the geotechnical investigation were to:

- ❑ Determine the existing subsoil and groundwater information at this site by means of boreholes.
- ❑ Provide geotechnical recommendations for the design of the proposed development including construction considerations which may affect its design.

The following report has been prepared specifically and solely for the aforementioned project which is described herein. It contains our findings and includes geotechnical recommendations pertaining to the design and construction of the subject development as they are understood at the time of writing this report.

## 2.0 Proposed Development

Based on the available drawings, it is understood that the proposed development will consist of a high-rise residential building, with two levels of underground parking which will extend beyond the footprint of the high-rise building. Asphalt-paved parking areas, walkways and landscaped areas surrounding the proposed building are also proposed.

Construction of the proposed development will involve demolition of the existing amenity building on-site.

## **3.0 Method of Investigation**

### **3.1 Field Investigation**

The field program for the geotechnical investigation was carried out from April 29 to May 3, 2021, and consisted of advancing 5 boreholes to a maximum depth of 22.6 m. The borehole locations were determined in the field by Paterson personnel taking into consideration site features and underground services. The locations of the boreholes are shown on Drawing PG5729-1 - Test Hole Location Plan in Appendix 2.

The boreholes were advanced using a low-clearance track-mounted auger drill rig operated by a two-person crew. All fieldwork was conducted under the full-time supervision of Paterson personnel under the direction of a senior engineer. The drilling procedure consisted of augering and rock coring to the required depths at the selected locations, and sampling and testing the overburden.

#### **Sampling and In Situ Testing**

Soil samples were collected from the boreholes using two different techniques, namely, sampled directly from the auger flights (AU) or collected using a 50 mm diameter split-spoon (SS) sampler. Rock cores (RC) were obtained using 47.6 mm inside diameter coring equipment. All samples were visually inspected and initially classified on site. The auger and split-spoon samples were placed in sealed plastic bags, and rock cores were placed in cardboard boxes. All samples were transported to our laboratory for further examination and classification. The depths at which the auger, split spoon and rock core samples were recovered from the boreholes are shown as AU, SS and RC, respectively, on the Soil Profile and Test Data sheets presented in Appendix 1.

A Standard Penetration Test (SPT) was conducted in conjunction with the recovery of the split spoon samples. The SPT results are recorded as "N" values on the Soil Profile and Test Data sheets. The "N" value is the number of blows required to drive the split spoon sampler 300 mm into the soil after a 150 mm initial penetration using a 63.5 kg hammer falling from a height of 760 mm.

A recovery value and a Rock Quality Designation (RQD) value were calculated for each drilled section (core run) of bedrock and are shown on the borehole logs. The recovery value is the ratio, in percentage, of the length of the bedrock sample recovered over the length of the drilled section (core run). The RQD value is the ratio, in percentage, of the total length of intact rock pieces longer than 100 mm in one core run over the length of the core run. These values are indicative of the quality of the bedrock.



The subsurface conditions observed in the test holes were recorded in detail in the field. The soil profiles are presented on the Soil Profile and Test Data sheets in Appendix 1.

### **Groundwater**

Monitoring wells were installed in boreholes BH 2-21 through BH 4-21 to permit monitoring of the groundwater levels subsequent to the completion of the sampling program. Flexible standpipes were also installed in boreholes BH 1-21 and BH 5-21.

All monitoring wells should be decommissioned in accordance with Ontario Regulations O.Reg 903 by a qualified licensed well technician and prior to construction.

### **Sample Storage**

All samples from the current investigation will be stored in the laboratory for a period of one month after issuance of this report. They will then be discarded unless we are otherwise directed.

## **3.2 Field Survey**

The borehole locations were selected by Paterson to provide general coverage of the proposed development, taking into consideration the existing site features and underground utilities. The borehole locations and ground surface elevations at each borehole location were surveyed by Paterson using a GPS unit with respect to a geodetic datum. The location of the boreholes and ground surface elevation at each borehole location are presented on Drawing PG5729-1 - Test Hole Location Plan in Appendix 2.

## **3.3 Laboratory Testing**

Soil and bedrock samples were recovered from the subject site and visually examined in our laboratory to review the results of the field logging.

## **3.4 Analytical Testing**

One soil sample was submitted for analytical testing to assess the corrosion potential for exposed ferrous metals and the potential of sulphate attacks against subsurface concrete structures. The sample was submitted to determine the concentration of sulphate and chloride, the resistivity and the pH of the sample. The results are presented in Appendix 1 and are discussed further in Subsection 6.7.

## **4.0 Observations**

### **4.1 Surface Conditions**

The subject site is located within the northeast portion of 1300 McWatters Road. The majority of the subject site is occupied by asphalt-paved access lanes, landscaped areas and a paved parking lot which are associated with the existing multi-storey building which borders the subject site to the east. An existing 1-storey amenity building is located within the southern limits of the subject site and is to be demolished prior to the construction of the proposed development. Landscaped areas are also located surrounding the existing structures.

Based on available aerial photos, a quarry was located within the subject site as recently as 1965. The quarry was infilled and construction of the aforementioned multi-storey building and amenity building were completed by 1976. Reference should be made to the aerial photographs in Figure 2 - Aerial Photograph - 1965 and Figure 3 - Aerial Photograph - 2019 which illustrate the former and present site conditions, respectively.

The subject site is bordered to the north by Lisa Avenue, to the east and southeast by an existing multi-storey residential building, to the south by an asphalt paved access lane associated with the existing residential complex, and to the west by Greenbank Road. The existing ground surface is relatively level across the subject site at approximate geodetic elevation of 77 to 78 m.

### **4.2 Subsurface Profile**

#### **Overburden**

Generally, the subsurface profile at the test hole locations consists of a 50 to 130 mm thick asphalt layer underlain by a 4.4 to 5.7 m thick fill layer. The fill material was generally observed to vary from a brown silty sand with trace gravel, to a brown to grey silty clay layer with sand and gravel, to topsoil with organics and wood with depth.

The fill was observed to be underlain by a deposit of compact to dense, brown to grey silty sand which was further underlain by bedrock.

## Bedrock

Practical refusal to augering on the bedrock surface was encountered at approximate depths of 19.3 and 18.1 m in boreholes BH 4-21 and BH 5-21, respectively. The bedrock was observed to consist of grey, interbedded quartz sandstone and limestone, and based on the RQDs of the recovered bedrock core, was generally of good to excellent in quality. At boreholes BH 4-21 and BH 5-21, The bedrock was cored to depths of from 22.6 to 21.1 m below the existing ground surface, respectively.

Reference should be made to the Soil Profile and Test Data sheets in Appendix 1 for specific details of the soil and bedrock profiles encountered at each test hole location.

## 4.3 Groundwater

Groundwater level readings were measured in the monitoring wells installed at boreholes BH 2-21 to BH 4-21 as well as the peizometers installed at boreholes BH 1-21 and BH 5-21 on May 12, 2021. The observed groundwater levels are summarized in Table 1 below.

<b>Table 1 - Summary of Groundwater Level Readings</b>				
<b>Test Hole Number</b>	<b>Ground Surface Elevation (m)</b>	<b>Groundwater Levels (m)</b>	<b>Groundwater Elevation (m)</b>	<b>Recording Date</b>
BH 1-21	76.83	8.24	68.59	May 12, 2021
BH 2-21*	77.50	7.48	70.02	May 12, 2021
BH 3-21*	76.62	7.98	68.64	May 12, 2021
BH 4-21*	76.88	7.53	69.35	May 12, 2021
BH 5-21	76.89	8.28	68.61	May 12, 2021
<p><b>Note:</b> Ground surface elevations at test hole locations were surveyed by Paterson and are referenced to a geodetic datum.                      *Denotes a monitoring well location.</p>				

It should be noted that groundwater levels could be influenced by surface water infiltrating the backfilled boreholes. The long-term groundwater level can also be estimated based on the recovered soil samples' moisture levels, colouring and consistency. Based on these observations, the long-term groundwater level is anticipated at a depth of approximately 7 to 9 m below ground surface. However, groundwater levels are subject to seasonal fluctuations and could vary at the time of construction.

## 5.0 Discussion

### 5.1 Geotechnical Assessment

From a geotechnical perspective, the subject site is suitable for the proposed development. It is recommended that the proposed multi-storey building be founded on one of the following:

- ❑ Conventional spread footings bearing on an undisturbed, compact to dense silty sand bearing surface.
- ❑ a raft foundation bearing on an undisturbed, compact to dense silty sand bearing surface.

Where the footings of the proposed building abut the neighbouring existing building, they should match the existing footing elevations.

The above and other considerations are further discussed in the following sections.

### 5.2 Site Grading and Preparation

#### Stripping Depth

Topsoil and fill, such as those containing organic or deleterious materials, should be stripped from under any buildings and other settlement sensitive structures.

Existing foundation walls and other construction debris should be entirely removed from within the proposed building perimeter and within the lateral support zones of the foundations. Under paved areas, existing construction remnants, such as foundation walls, should be excavated to a minimum of 1 m below final grade.

#### Fill Placement

Fill used for grading beneath the proposed building should consist of clean imported granular fill, such as Ontario Provincial Standard Specifications (OPSS) Granular A or Granular B Type II. The fill should be tested and approved prior to delivery to the site. The fill should be placed in lifts no greater than 300 mm thick and compacted using suitable compaction equipment for the lift thickness.

Fill placed beneath the building and paved areas should be compacted to at least 98% of its standard Proctor maximum dry density (SPMDD).

Non-specified existing fill, along with site excavated soil, can be used as general landscaping fill where settlement of the ground surface is of minor concern. This material should be spread in thin lifts and at least compacted by the tracks of the spreading equipment to minimize voids. If this material is to be used to build up the subgrade level for areas to be paved, it should be compacted in thin lifts to at least 95% of the material's SPMD.

Non-specified existing fill and site excavated soils are not suitable for use as backfill against foundation walls unless used in conjunction with a composite drainage membrane.

## 5.3 Foundation Design

### Conventional Spread Footings

Footings placed on an undisturbed, compact to dense silty sand bearing surface can be designed using a bearing resistance value at serviceability limit states (SLS) of **300 kPa** and a factored bearing resistance value at ultimate limit states (ULS) of **450 kPa**. A geotechnical resistance factor of 0.5 was applied to the above noted bearing resistance value at ULS.

The bearing resistance value at SLS will be subjected to potential post-construction total and differential settlements of 25 and 20 mm, respectively.

An undisturbed soil bearing surface consists of a surface from which all topsoil and deleterious materials, such as loose, frozen or disturbed soil, whether in situ or not, have been removed, in the dry, prior to the placement of concrete for footings.

As a general procedure, it is recommended that the footings for the proposed building that are located adjacent to the existing neighbouring structure be founded at the same level as the existing footings. This accomplishes three objectives. First, the behaviour of the two structures at their connection will be similar due to the similar bearing medium. Second, there will be minimal stress added to the existing structure from the new structure. Third, the bearing of the new structure will not be influenced by any backfill from the existing structure.

### Raft Foundation

As noted above, it is expected that a raft foundation may be required to support the proposed multi-storey building. The maximum SLS contact pressure recommended is **350 kPa** for a raft foundation bearing on the undisturbed, compact to dense silty sand.

It should be noted that the weight of the raft slab and everything above has to be included when designing with this value. The loading conditions for the contact pressure are based on sustained loads, that are generally taken to be 100% Dead Load and 50% Live Load. The factored bearing resistance (contact pressure) at ULS can be taken as **525 kPa**. A geotechnical resistance factor of 0.5 was applied to the bearing resistance value at ULS.

The modulus of subgrade reaction was calculated to be **14 MPa/m** for a contact pressure of **350 kPa**. The design of the raft foundation is required to consider the relative stiffness of the reinforced concrete slab and the supporting bearing medium. A common method of modeling the soil structure interaction is to consider the bearing medium to be elastic and to assign a subgrade modulus. However, silty sand is not elastic and limits have to be placed on the stress ranges of a particular modulus.

The proposed building can be designed using the above parameters with total and differential settlements of 25 and 20 mm, respectively.

### **Lateral Support**

The bearing medium under footing-supported structures is required to be provided with adequate lateral support with respect to excavations and different foundation levels. Adequate lateral support is provided to the undisturbed, compact to dense silty sand above the groundwater table, when a plane extending down and out from the bottom edge of the footing at a minimum of 1.5H:1V passes only through in situ soil of the same or higher capacity as the bearing medium soil.

## **5.4 Design for Earthquakes**

The site class for seismic site response can be taken as **Class D**. If a higher seismic site class is required (Class C), a site specific shear wave velocity test may be completed to accurately determine the applicable seismic site classification for foundation design of the proposed building, as presented in Table 4.1.8.4.A of the Ontario Building Code (OBC) 2012.

Soils underlying the subject site are not susceptible to liquefaction. Reference should be made to the latest revision of the OBC 2012 for a full discussion of the earthquake design requirements.

## 5.5 Basement Floor Slab

With the removal of all topsoil and deleterious fill from within the footprint of the proposed building, the native soil surface will be considered an acceptable subgrade on which to commence backfilling for floor slab construction. It is anticipated that the basement area for the proposed building will be mostly parking and the recommended pavement structures noted in Subsection 5.7 will be applicable. However, if storage or other uses of the lower level will involve the construction of a concrete floor slab, the upper 200 mm of sub-slab fill is recommended to consist of 19 mm clear crushed stone.

All backfill material within the footprint of the proposed building should be placed in maximum 300 mm thick loose layers and compacted to a minimum of 98% of the SPMDD.

If a raft slab is considered for the proposed multi-storey building, a granular layer of OPSS Granular A crushed stone will be required to allow for the installation of sub-floor services above the raft slab foundation. The thickness of the OPSS Granular A crushed stone will be dependent on the piping requirements.

In consideration of the groundwater conditions encountered at the time of the field investigation, a sub-slab drainage system, consisting of lines of perforated drainage pipe subdrains connected to a sump pit, should be provided in the subfloor fill under the lower basement floor (discussed further in Subsection 6.1).

## 5.6 Basement Wall

There are several combinations of backfill materials and retained soils that could be applicable for the basement walls of the subject structure. However, the conditions can be well-represented by assuming the retained soil consists of a material with an angle of internal friction of 30 degrees and a bulk (drained) unit weight of 20 kN/m<sup>3</sup>.

Where undrained conditions are anticipated (i.e. below the groundwater level), the applicable effective (undrained) unit weight of the retained soil can be taken as 13 kN/m<sup>3</sup>, where applicable. A hydrostatic pressure should be added to the total static earth pressure when using the effective unit weight.

### Lateral Earth Pressures

The static horizontal earth pressure ( $p_o$ ) can be calculated using a triangular earth pressure distribution equal to  $K_o \cdot \gamma \cdot H$  where:

- $K_o$  = at-rest earth pressure coefficient of the applicable retained soil (0.5)
- $\gamma$  = unit weight of fill of the applicable retained soil (kN/m<sup>3</sup>)
- H = height of the wall (m)

An additional pressure having a magnitude equal to  $K_o \cdot q$  and acting on the entire height of the wall should be added to the above diagram for any surcharge loading,  $q$  (kPa), that may be placed at ground surface adjacent to the wall. The surcharge pressure will only be applicable for static analyses and should not be used in conjunction with the seismic loading case.

Actual earth pressures could be higher than the “at-rest” case if care is not exercised during the compaction of the backfill materials to maintain a minimum separation of 0.3 m from the walls with the compaction equipment.

### Seismic Earth Pressures

The total seismic force ( $P_{AE}$ ) includes both the earth force component ( $P_o$ ) and the seismic component ( $\Delta P_{AE}$ ).

The seismic earth force ( $\Delta P_{AE}$ ) can be calculated using  $0.375 \cdot a_c \cdot \gamma \cdot H^2/g$  where:

- $a_c = (1.45 - a_{max}/g) a_{max}$
- $\gamma$  = unit weight of fill of the applicable retained soil (kN/m<sup>3</sup>)
- H = height of the wall (m)
- g = gravity, 9.81 m/s<sup>2</sup>

The peak ground acceleration, ( $a_{max}$ ), for the Ottawa area is 0.32g according to OBC 2012. Note that the vertical seismic coefficient is assumed to be zero.

The earth force component ( $P_o$ ) under seismic conditions can be calculated using  $P_o = .5 K_o \gamma H^2$ , where  $K_o = 0.5$  for the soil conditions noted above.

The total earth force ( $P_{AE}$ ) is considered to act at a height,  $h$  (m), from the base of the wall, where:

$$h = \{P_o \cdot (H/3) + \Delta P_{AE} \cdot (0.6 \cdot H)\} / P_{AE}$$

The earth forces calculated are unfactored. For the ULS case, the earth loads should be factored as live loads, as per OBC 2012.



## 5.7 Pavement Structure

For design purposes, it is recommended that the rigid pavement structure for the lower underground parking level consist of Category C2, 32 MPa concrete at 28 days with air entrainment of 5 to 8%. The recommended rigid pavement structure is further presented in Table 2 below. The flexible pavement structure presented in Table 3 should be used for at grade access lanes and heavy loading parking areas.

<b>Table 2 - Recommended Rigid Pavement Structure - Lower Parking Level</b>	
<b>Thickness (mm)</b>	<b>Material Description</b>
150	<b>Exposure Class C2 - 32 MPa Concrete</b> (5 to 8% Air Entrainment)
300	<b>BASE</b> - OPSS Granular A Crushed Stone
<b>SUBGRADE</b> - Existing imported fill, or OPSS Granular B Type I or II material placed over bedrock.	

To control cracking due to shrinking of the concrete floor slab, it is recommended that strategically located saw cuts be used to create control joints within the concrete floor slab of the lower underground parking level. The control joints are generally recommended to be located at the center of the column lines and spaced at approximately 24 to 36 times the slab thickness (for example; a 0.15 m thick slab should have control joints spaced between 3.6 and 5.4 m). The joints should be cut between 25 and 30% of the thickness of the concrete floor slab and completed as early as 4 hour after the concrete has been poured during warm temperatures and up to 12 hours during cooler temperatures.

<b>Table 3 - Recommended Asphalt Pavement Structure - Access Lanes and Heavy Loading Parking Areas</b>	
<b>Thickness (mm)</b>	<b>Material Description</b>
40	<b>Wear Course</b> - Superpave 12.5 Asphaltic Concrete
50	<b>Binder Course</b> - Superpave 19.0 Asphaltic Concrete
150	<b>BASE</b> - OPSS Granular A Crushed Stone
300	<b>SUBBASE</b> - OPSS Granular B Type II
<b>SUBGRADE</b> - OPSS Granular B Type II overlying the Concrete Podium Deck.	

Minimum Performance Graded (PG) 58-34 asphalt cement should be used for this project.

If soft spots develop in the subgrade during compaction or due to construction traffic, the affected areas should be excavated and replaced with OPSS Granular B Type II material. The pavement granular base and subbase should be placed in maximum 300 mm thick lifts and compacted to a minimum of 99% of the material's SPMDD using suitable vibratory equipment.

## **6.0 Design and Construction Precautions**

### **6.1 Foundation Drainage and Backfill**

#### **Foundation Drainage**

It is recommended that a perimeter foundation drainage system be provided for the proposed structure. The system should consist of a 150 mm diameter, perforated and corrugated plastic pipe, surrounded on all sides by 150 mm of 10 mm clear crushed stone, which is placed at the footing level around the exterior perimeter of the structure. The pipes should have a positive outlet, such as a gravity connection to the storm sewer.

Where insufficient room is available for exterior backfill, it is suggested that the composite drainage system (such as Delta Drain 6000 or equivalent) be secured against the temporary shoring system, extending to a series of drainage sleeve inlets through the building foundation wall at the footing/foundation wall interface. The drainage sleeves should be at least 150 mm diameter and be spaced 3 m along the perimeter foundation walls. An interior perimeter drainage pipe should be placed along the building perimeter along with the sub-slab drainage system. The perimeter drainage pipe and sub-slab drainage system should direct water to sump pit(s) within the underground level.

#### **Foundation Raft Slab Construction Joints**

If applicable, it is expected that the raft slab will be poured in sections. For the construction joint at each pour, a rubber water stop along with a chemical grout (Xypex or equivalent) should be applied to the entire vertical joint of the raft slab. Furthermore, a rubber water stop should be incorporated in the horizontal interface between the foundation wall and the raft slab.

#### **Sub-slab Drainage**

Sub-slab drainage will be required to control water infiltration. For preliminary design purposes, we recommend that 150 mm diameter perforated pipes be placed at approximate 6 m centres underlying the lowest level floor slab. The spacing of the sub-slab drainage system should be confirmed at the time of completing the excavation when water infiltration can be better assessed.

## **Foundation Backfill**

Where sufficient space is available for conventional backfilling, the backfill material against the exterior sides of the foundation walls should consist of free-draining, non frost susceptible granular materials. The site materials will be frost susceptible and, as such, are not recommended for re-use as backfill unless a composite drainage system (such as Delta Drain 6000) connected to a drainage system is provided.

## **6.2 Protection of Footings Against Frost Action**

Perimeter footings of heated structures are recommended to be protected against the deleterious effects of frost action. A minimum of 1.5 m of soil cover, or an equivalent combination of soil cover and foundation insulation, should be provided in this regard.

Exterior unheated footings, such as isolated exterior piers, are more prone to deleterious movement associated with frost action than the exterior walls of the structure proper and require additional protection, such as soil cover of 2.1 m or a combination of soil cover and foundation insulation.

However, the foundations are generally not expected to require protection against frost action due to the founding depth. Unheated structures such as the access ramp may require insulation for protection against the deleterious effects of frost action.

## **6.3 Excavation Side Slopes**

The side slopes of excavations in the overburden materials should either be cut back at acceptable slopes or should be retained by shoring systems from the start of the excavation until the structure is backfilled.

### **Unsupported Excavations**

The excavation side slopes above the groundwater level extending to a maximum depth of 3 m should be excavated at 1H:1V or shallower. The shallower slope is required for excavation below groundwater level. The subsurface soils are considered to be a Type 2 and 3 soil according to the Occupational Health and Safety Act and Regulations for Construction Projects.

Excavated soil should not be stockpiled directly at the top of excavations and heavy equipment should be kept away from the excavation sides. Slopes in excess of 3 m in height should be periodically inspected by the geotechnical consultant in order to detect if the slopes are exhibiting signs of distress.

A trench box is recommended to protect personnel working in trenches with steep or vertical sides. Services are expected to be installed by “cut and cover” methods and excavations should not remain open for extended periods of time.

### **Temporary Shoring**

Due to the anticipated proximity of the proposed building to the north and west property boundaries, temporary shoring may be required to support the overburden soils of the adjacent properties. The design and approval of the shoring system will be the responsibility of the shoring contractor and the shoring designer who is a licensed professional engineer and is hired by the shoring contractor. It is the responsibility of the shoring contractor to ensure that the temporary shoring is in compliance with safety requirements, designed to avoid any damage to adjacent structures and include dewatering control measures.

In the event that subsurface conditions differ from the approved design during the actual installation, it is the responsibility of the shoring contractor to commission the required experts to re-assess the design and implement the required changes.

The designer should also take into account the impact of a significant precipitation event and designate design measures to ensure that a precipitation will not negatively impact the shoring system or soils supported by the system. Any changes to the approved shoring design system should be reported immediately to the owner’s structural designer prior to implementation.

The temporary shoring system may consist of a soldier pile and lagging system or steel sheet piles which could be cantilevered, anchored or braced. The shoring system is recommended to be adequately supported to resist toe failure.

Any additional loading due to street traffic, construction equipment, adjacent structures and facilities, etc., should be added to the earth pressures described on the following page.

The earth pressures acting on the shoring system may be calculated using the parameters on the next page:

<b>Table 4 - Soil Parameters</b>	
<b>Parameters</b>	<b>Values</b>
Active Earth Pressure Coefficient ( $K_a$ )	0.33
Passive Earth Pressure Coefficient ( $K_p$ )	3
At-Rest Earth Pressure Coefficient ( $K_o$ )	0.5
Unit Weight ( $\gamma$ ), kN/m <sup>3</sup>	21
Submerged Unit Weight ( $\gamma$ ), kN/m <sup>3</sup>	13

The active earth pressure should be calculated where wall movements are permissible while the at-rest pressure should be calculated if no movement is permissible. The dry unit weight should be calculated above the groundwater level while the effective unit weight should be calculated below the groundwater level.

The hydrostatic groundwater pressure should be included to the earth pressure distribution wherever the effective unit weight are calculated for earth pressures. If the groundwater level is lowered, the dry unit weight for the soil should be calculated full weight, with no hydrostatic groundwater pressure component.

For design purposes, the minimum factor of safety of 1.5 should be calculated.

### **Underpinning of Adjacent Structures**

If the excavation for the proposed building is to extend within the lateral support zone of the adjacent building foundations, underpinning of these structures would be required. The depth of the underpinning, if required, would be dependent on the depth of the neighbouring foundations relative to the founding depth of the proposed building at the subject site.

## **6.4 Pipe Bedding and Backfill**

Bedding and backfill materials should be in accordance with the most recent Material Specifications & Standard Detail Drawings from the Department of Public Works and Services, Infrastructure Services Branch of the City of Ottawa.

A minimum of 150 mm of OPSS Granular A should be placed for bedding for sewer or water pipes when placed on a soil subgrade. The bedding should extend to the spring line of the pipe. Cover material, from the spring line to a minimum of 300 mm above the obvert of the pipe, should consist of OPSS Granular A (concrete or PSM PVC pipes) or sand (concrete pipe). The bedding and cover materials should be placed in maximum 225 mm thick lifts and compacted to 98% of the SPMDD.

It should generally be possible to re-use the site materials above the cover material if the operations are carried out in dry weather conditions.

Where hard surface areas are considered above the trench backfill, the trench backfill material within the frost zone (about 1.8 m below finished grade) and above the cover material should match the soils exposed at the trench walls to minimize differential frost heaving. The trench backfill should be placed in maximum 225 mm thick loose lifts and compacted to a minimum of 95% of the material's SPMDD. All cobbles larger than 200 mm in their longest direction should be segregated from re-use as trench backfill.

## **6.5 Groundwater Control**

It is anticipated that groundwater infiltration into the excavations should be controllable using open sumps. The contractor should be prepared to direct water away from all bearing surfaces and subgrades, regardless of the source, to prevent disturbance to the founding medium.

### **Groundwater Control for Building Construction**

A temporary Ministry of Environment, Conservation and Parks (MECP) permit to take water (PTTW) may be required if more than 400,000 L/day of ground and/or surface water are to be pumped during the construction phase. At least 4 to 5 months should be allowed for completion of the application and issuance of the permit by the MECP.

For typical ground or surface water volumes being pumped during the construction phase, typically between 50,000 to 400,000 L/day, it is required to register on the Environmental Activity and Sector Registry (EASR). A minimum of two to four weeks should be allotted for completion of the EASR registration and the Water Taking and Discharge Plan to be prepared by a Qualified Person as stipulated under O.Reg. 63/16. If a project qualifies for a PTTW based upon anticipated conditions, an EASR will not be allowed as a temporary dewatering measure while awaiting the MECP review of the PTTW application.

### **Impacts on Neighbouring Properties**

The proposed building is not anticipated to extend significantly below the groundwater level, therefore, any dewatering at the site will be minimal and should have no adverse effects to the surrounding buildings or structures. The short term dewatering during the excavation program will be managed by the excavation contractor.

## **6.6 Winter Construction**

Precautions must be taken if winter construction is considered for this project. The subsoil conditions at this site consist of frost susceptible materials. In the presence of water and freezing conditions, ice could form within the soil mass. Heaving and settlement upon thawing could occur.

In the event of construction during below zero temperatures, the founding stratum should be protected from freezing temperatures by the use of straw, propane heaters and tarpaulins or other suitable means. In this regard, the base of the excavations should be insulated from sub-zero temperatures immediately upon exposure and until such time as heat is adequately supplied to the building and the footings are protected with sufficient soil cover to prevent freezing at founding level.

Trench excavations and pavement construction are also difficult activities to complete during freezing conditions without introducing frost in the subgrade or in the excavation walls and bottoms. Precautions should be taken if such activities are to be carried out during freezing conditions. Additional information could be provided, if required.

## **6.7 Corrosion Potential and Sulphate**

The results of the analytical testing show that the sulphate content is less than 0.1%. This result is indicative that Type 10 Portland cement (normal cement) would be appropriate for this site. The chloride content and the pH of the sample indicate that they are not significant factors in creating a corrosive environment for exposed ferrous metals at this site, whereas the resistivity is indicative of an aggressive to very aggressive corrosive environment.



## 7.0 Recommendations

A materials testing and observation services program is also a requirement for the foundation design data to be applicable. The following aspects of the program should be performed by the geotechnical consultant:

- Review of the geotechnical aspects of the excavation contractor's design of the temporary shoring system, if required.
- Observation of all bearing surfaces prior to the placement of concrete.
- Sampling and testing of the concrete and fill materials used.
- Periodic observation of the condition of unsupported excavation side slopes in excess of 3 m in height, if applicable.
- Observation of all subgrades prior to backfilling.
- Field density tests to determine the level of compaction achieved.
- Sampling and testing of the bituminous concrete including mix design reviews.

A report confirming that these works have been conducted in general accordance with our recommendations could be issued, upon request, following the completion of a satisfactory materials testing and observation program by the geotechnical consultant.

## 8.0 Statement of Limitations

The recommendations provided in this report are in accordance with our present understanding of the project. We request permission to review our recommendations when the drawings and specifications are completed.

A geotechnical investigation is a limited sampling of a site. Should any conditions at the site be encountered which differ from those at the test locations, we request immediate notification to permit reassessment of our recommendations.

The recommendations provided herein should only be used by the design professionals associated with this project. They are not intended for contractors bidding on or undertaking the work. The latter should evaluate the factual information provided in this report and determine its suitability and completeness for their intended construction schedule and methods. Additional testing may be required for their purposes.

The present report applies only to the project described in this document. Use of this report for purposes other than those described herein or by person(s) other than Homestead Land Holdings Inc. or their agents is not authorized without review by Paterson Group for the applicability of our recommendations to the altered use of the report.

**Paterson Group Inc.**



Kevin A. Pickard, EIT



Scott S. Dennis, P.Eng.

**Report Distribution:**

- Homestead Land Holdings Inc. (e-mail copy)
- Paterson Group (1 copy)

# **APPENDIX 1**

**SOIL PROFILE & TEST DATA SHEETS**

**SYMBOLS AND TERMS**

**ANALYTICAL TESTING RESULTS**

DATUM Geodetic

REMARKS

BORINGS BY CME-55 Low Clearance Drill

DATE April 29, 2021

FILE NO. **PG5729**

HOLE NO. **BH 1-21**

SOIL DESCRIPTION	STRATA PLOT	SAMPLE				DEPTH (m)	ELEV. (m)	Pen. Resist. Blows/0.3m ● 50 mm Dia. Cone				Piezometer Construction	
		TYPE	NUMBER	RECOVERY %	N VALUE or RQD			○ Water Content %					
								20	40	60	80		
<b>GROUND SURFACE</b>													
TOPSOIL	0.13	AU	1			0	76.83						
FILL: Brown silty sand, some gravel, trace clay	2.13	SS	2	83	14	1	75.83						
		SS	3	50	23	2	74.83						
FILL: Brown to grey silty clay with sand, some topsoil, organics and gravel	3.50	SS	4	100	9	3	73.83						
		SS	5	75	11	4	72.83						
FILL: Topsoil and organics with some sand, trace wood	5.18	SS	6	100	16	5	71.83						
		SS	7	100	14	6	70.83						
Dense, brown <b>SILTY SAND to SANDY SILT</b>	6.00	SS	8	100	39	7	69.83						
		SS	9	100	25	8	68.83						
Compact, brown <b>SILTY SAND</b>	9.75	SS	10	75	15	9	67.83						
		SS	11	58	17	10							
		SS	12	83	15	11							
		SS	13	83	13	12							
End of Borehole (GWL @ 8.24m - May 12, 2021)													

20 40 60 80 100  
**Shear Strength (kPa)**  
 ▲ Undisturbed    △ Remoulded

DATUM Geodetic

REMARKS

BORINGS BY CME-55 Low Clearance Drill

DATE April 29, 2021

FILE NO. **PG5729**

HOLE NO. **BH 2-21**

SOIL DESCRIPTION	STRATA PLOT	SAMPLE				DEPTH (m)	ELEV. (m)	Pen. Resist. Blows/0.3m ● 50 mm Dia. Cone				Monitoring Well Construction	
		TYPE	NUMBER	RECOVERY %	N VALUE or RQD			○ Water Content %					
GROUND SURFACE								20	40	60	80		
Asphaltic concrete	0.10					0	77.50						
<b>FILL:</b> Brown silty sand with crushed stone	0.46	AU	1										
		SS	2	92	5	1	76.50						
<b>FILL:</b> Brown silty sand, trace gravel		SS	3	50	7	2	75.50						
	2.21												
<b>FILL:</b> Brown to grey silty clay with sand and gravel		SS	4	75	12	3	74.50						
	2.97												
		SS	5	67	8	4	73.50						
<b>FILL:</b> Brown silty sand, trace gravel		SS	6	67	8	5	72.50						
- some rock fragments by 4.0m depth		SS	7	75	18	6	71.50						
- trace topsoil and wood by 4.6m depth		SS	8	75	11	7	70.50						
	5.84												
		SS	9	75	20	8	69.50						
<b>Compact, brown SILTY SAND</b>		SS	10	67	14	9	68.50						
- loose to very loose by 8.4m depth		SS	11	58	12	10	67.50						
- running sand encountered below a depth of 8.4m		SS	12	83	7	11	66.50						
	9.75												
End of Borehole		SS	13	100	2	12	65.50						
(GWL @ 7.48m - May 12, 2021)													

20 40 60 80 100  
**Shear Strength (kPa)**  
 ▲ Undisturbed    △ Remoulded

DATUM Geodetic

FILE NO. **PG5729**

REMARKS

HOLE NO. **BH 3-21**

BORINGS BY CME-55 Low Clearance Drill

DATE April 29, 2021

SOIL DESCRIPTION	STRATA PLOT	SAMPLE			DEPTH (m)	ELEV. (m)	Pen. Resist. Blows/0.3m ● 50 mm Dia. Cone				Monitoring Well Construction	
		TYPE	NUMBER	RECOVERY %			N VALUE or RQD	20	40	60		80
<b>GROUND SURFACE</b>												
<b>TOPSOIL</b>	0.15	AU	1		0	76.62						
<b>FILL:</b> Brown to grey silty sand to silty clay, some gravel, trace topsoil		SS	2	100	1	75.62						
		SS	3	100	2	74.62						
		SS	4	75	12	3	73.62					
		SS	5	67	16	4	72.62					
		SS	6	75	13	5	71.62					
<b>FILL:</b> Topsoil and organics, some sand, trace wood	3.73	SS	7	58	6	70.62						
		SS	8	73	50+	7	69.62					
<b>Dense to compact, brown SILTY SAND</b>	5.03	SS	9	67	37	8	68.62					
		SS	10	83	13	9	67.62					
		SS	11	58	13	10	66.62					
		SS	12	67	11	11	65.62					
		SS	13	83	15	12	64.62					
End of Borehole	9.75											
(GWL @ 7.98m - May 12, 2021)												

20 40 60 80 100  
**Shear Strength (kPa)**  
▲ Undisturbed    △ Remoulded

DATUM Geodetic



REMARKS

BORINGS BY CME-55 Low Clearance Drill

DATE April 30, 2021

FILE NO. **PG5729**

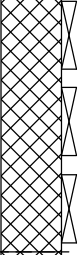
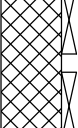
HOLE NO. **BH 4-21**

SOIL DESCRIPTION	STRATA PLOT	SAMPLE				DEPTH (m)	ELEV. (m)	Pen. Resist. Blows/0.3m ● 50 mm Dia. Cone				Monitoring Well Construction	
		TYPE	NUMBER	RECOVERY %	N VALUE or RQD			○ Water Content %					
								20	40	60	80		
<b>GROUND SURFACE</b>													
<b>FILL:</b> Topsoil and organics with silty sand		AU	1			0	76.88						
<b>FILL:</b> Brown silty sand, trace gravel and organics - some clay by 2.3m depth		SS	2	50	10	1	75.88						
		SS	3	25	5	2	74.88						
		SS	4	17	4	3	73.88						
	2.97	SS	5	50	10	4	72.88						
<b>FILL:</b> Brown to grey silty sand/silty clay, trace gravel and topsoil		SS	6	92	7	5	71.88						
	4.50	SS	7	67	13	6	70.88						
<b>FILL:</b> Topsoil and organics, some wood		SS	8	83	32	7	69.88						
Dense, brown <b>SILTY SAND to SANDY SILT</b>	5.03	SS	9	58	23	8	68.88						
	5.64	SS	10	75	17	9	67.88						
		SS	11	83	15	10	66.88						
		SS	12	83	8	11	65.88						
Compact, brown <b>SILTY SAND</b>		SS	13	75	12	12	64.88						
		SS	14	33	11								

20 40 60 80 100  
**Shear Strength (kPa)**  
▲ Undisturbed    △ Remoulded

DATUM Geodetic

REMARKS

BORINGS BY CME-55 Low Clearance Drill

DATE April 30, 2021

FILE NO. **PG5729**

HOLE NO. **BH 4-21**

SOIL DESCRIPTION	STRATA PLOT	SAMPLE				DEPTH (m)	ELEV. (m)	Pen. Resist. Blows/0.3m ● 50 mm Dia. Cone				Monitoring Well Construction	
		TYPE	NUMBER	RECOVERY %	N VALUE or RQD			○ Water Content %					
								20	40	60	80		
GROUND SURFACE						12	64.88						
Compact, brown <b>SILTY SAND</b>  - dense and grey by 15.2m depth		SS	15	33	23	13	63.88						
		SS	16	50	20	14	62.88						
		SS	17	42	49	15	61.88						
		SS	18	33	37	16	60.88						
		SS	19	33	41	17	59.88						
		SS	19	33	41	18	58.88						
<b>BEDROCK:</b> Good quality, grey interbedded quartz sandstone and limestone		RC	1	100	78	19	57.88						
		RC	1	100	78	20	56.88						
		RC	2	100	88	21	55.88						
		RC	2	100	88	22	54.88						
End of Borehole (GWL @ 7.53m - May 12, 2021)													

20 40 60 80 100  
**Shear Strength (kPa)**  
 ▲ Undisturbed    △ Remoulded



DATUM Geodetic

REMARKS

BORINGS BY CME-55 Low Clearance Drill

DATE May 3, 2021

FILE NO. **PG5729**

HOLE NO. **BH 5-21**

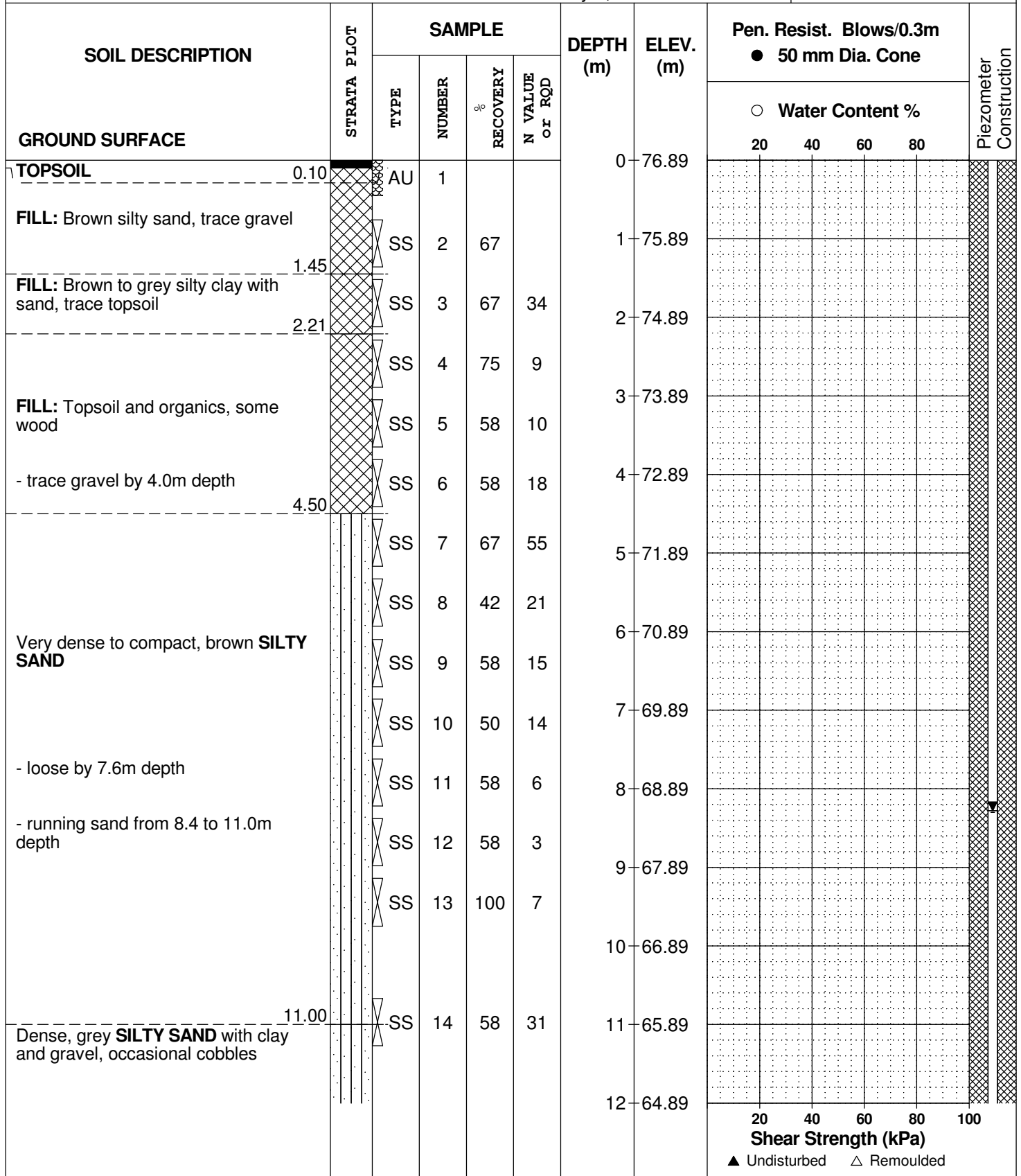

DATUM Geodetic

REMARKS

BORINGS BY CME-55 Low Clearance Drill

DATE May 3, 2021

FILE NO. **PG5729**

HOLE NO. **BH 5-21**

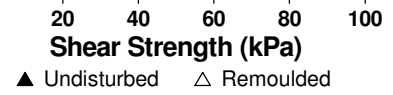
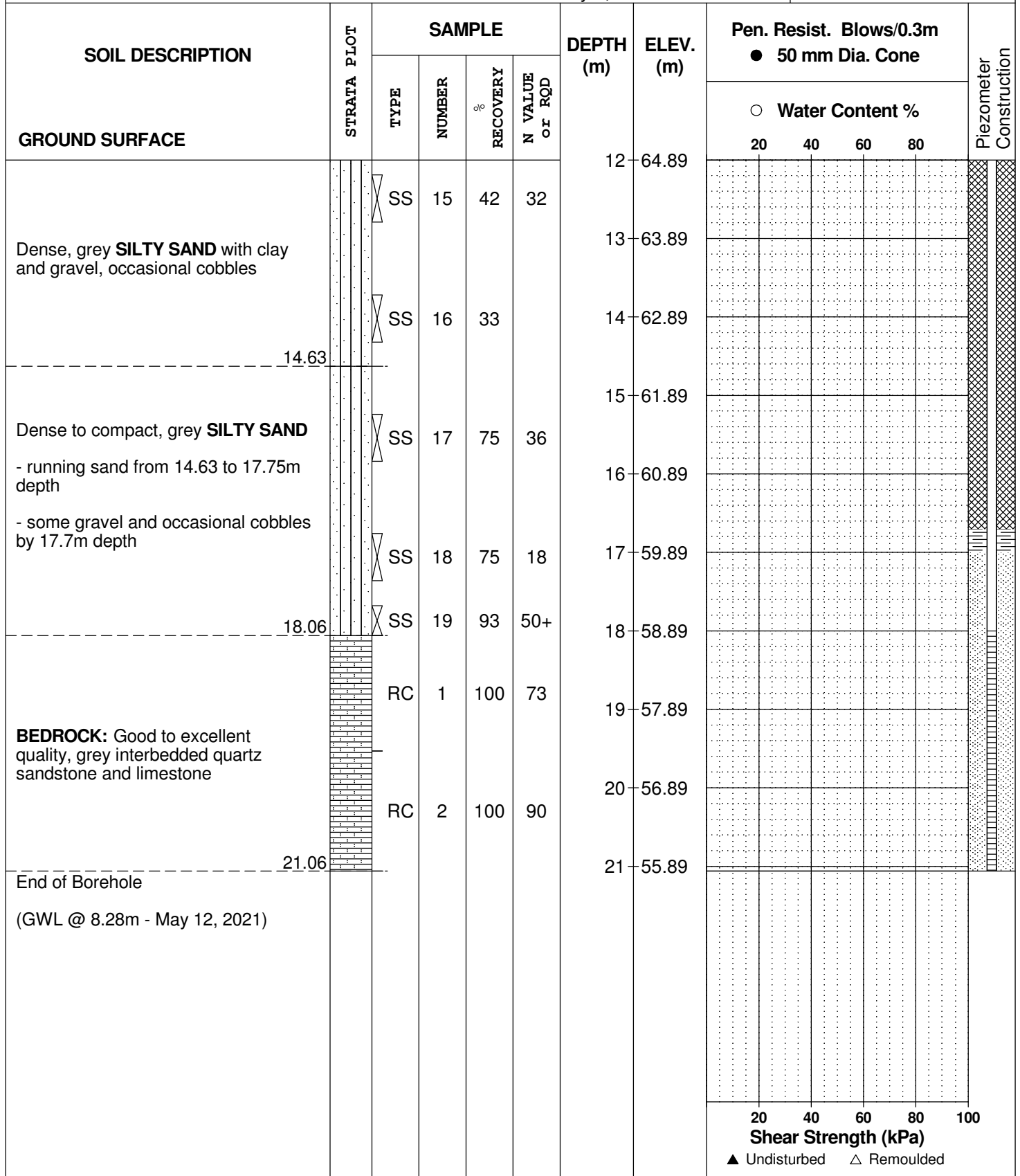

# SYMBOLS AND TERMS

## SOIL DESCRIPTION

Behavioural properties, such as structure and strength, take precedence over particle gradation in describing soils. Terminology describing soil structure are as follows:

Desiccated	-	having visible signs of weathering by oxidation of clay minerals, shrinkage cracks, etc.
Fissured	-	having cracks, and hence a blocky structure.
Varved	-	composed of regular alternating layers of silt and clay.
Stratified	-	composed of alternating layers of different soil types, e.g. silt and sand or silt and clay.
Well-Graded	-	Having wide range in grain sizes and substantial amounts of all intermediate particle sizes (see Grain Size Distribution).
Uniformly-Graded	-	Predominantly of one grain size (see Grain Size Distribution).

The standard terminology to describe the relative strength of cohesionless soils is the compactness condition, usually inferred from the results of the Standard Penetration Test (SPT) 'N' value. The SPT N value is the number of blows of a 63.5 kg hammer, falling 760 mm, required to drive a 51 mm O.D. split spoon sampler 300 mm into the soil after an initial penetration of 150 mm. An SPT N value of "P" denotes that the split-spoon sampler was pushed 300 mm into the soil without the use of a falling hammer.

Compactness Condition	'N' Value	Relative Density %
Very Loose	<4	<15
Loose	4-10	15-35
Compact	10-30	35-65
Dense	30-50	65-85
Very Dense	>50	>85

The standard terminology to describe the strength of cohesive soils is the consistency, which is based on the undisturbed undrained shear strength as measured by the in situ or laboratory shear vane tests, unconfined compression tests, or occasionally by the Standard Penetration Test (SPT). Note that the typical correlations of undrained shear strength to SPT N value (tabulated below) tend to underestimate the consistency for sensitive silty clays, so Paterson reviews the applicable split spoon samples in the laboratory to provide a more representative consistency value based on tactile examination.

Consistency	Undrained Shear Strength (kPa)	'N' Value
Very Soft	<12	<2
Soft	12-25	2-4
Firm	25-50	4-8
Stiff	50-100	8-15
Very Stiff	100-200	15-30
Hard	>200	>30

## SYMBOLS AND TERMS (continued)

### SOIL DESCRIPTION (continued)

Cohesive soils can also be classified according to their “sensitivity”. The sensitivity,  $S_t$ , is the ratio between the undisturbed undrained shear strength and the remoulded undrained shear strength of the soil. The classes of sensitivity may be defined as follows:

Low Sensitivity:	$S_t < 2$
Medium Sensitivity:	$2 < S_t < 4$
Sensitive:	$4 < S_t < 8$
Extra Sensitive:	$8 < S_t < 16$
Quick Clay:	$S_t > 16$

### ROCK DESCRIPTION

The structural description of the bedrock mass is based on the Rock Quality Designation (RQD).

The RQD classification is based on a modified core recovery percentage in which all pieces of sound core over 100 mm long are counted as recovery. The smaller pieces are considered to be a result of closely-spaced discontinuities (resulting from shearing, jointing, faulting, or weathering) in the rock mass and are not counted. RQD is ideally determined from NQ or larger size core. However, it can be used on smaller core sizes, such as BQ, if the bulk of the fractures caused by drilling stresses (called “mechanical breaks”) are easily distinguishable from the normal in situ fractures.

RQD %	ROCK QUALITY
90-100	Excellent, intact, very sound
75-90	Good, massive, moderately jointed or sound
50-75	Fair, blocky and seamy, fractured
25-50	Poor, shattered and very seamy or blocky, severely fractured
0-25	Very poor, crushed, very severely fractured

### SAMPLE TYPES

SS	-	Split spoon sample (obtained in conjunction with the performing of the Standard Penetration Test (SPT))
TW	-	Thin wall tube or Shelby tube, generally recovered using a piston sampler
G	-	"Grab" sample from test pit or surface materials
AU	-	Auger sample or bulk sample
WS	-	Wash sample
RC	-	Rock core sample (Core bit size BQ, NQ, HQ, etc.). Rock core samples are obtained with the use of standard diamond drilling bits.

## SYMBOLS AND TERMS (continued)

### PLASTICITY LIMITS AND GRAIN SIZE DISTRIBUTION

WC%	-	Natural water content or water content of sample, %
LL	-	Liquid Limit, % (water content above which soil behaves as a liquid)
PL	-	Plastic Limit, % (water content above which soil behaves plastically)
PI	-	Plasticity Index, % (difference between LL and PL)
D <sub>xx</sub>	-	Grain size at which xx% of the soil, by weight, is of finer grain sizes These grain size descriptions are not used below 0.075 mm grain size
D <sub>10</sub>	-	Grain size at which 10% of the soil is finer (effective grain size)
D <sub>60</sub>	-	Grain size at which 60% of the soil is finer
C <sub>c</sub>	-	Concavity coefficient = $(D_{30})^2 / (D_{10} \times D_{60})$
C <sub>u</sub>	-	Uniformity coefficient = $D_{60} / D_{10}$

C<sub>c</sub> and C<sub>u</sub> are used to assess the grading of sands and gravels:

Well-graded gravels have:  $1 < C_c < 3$  and  $C_u > 4$

Well-graded sands have:  $1 < C_c < 3$  and  $C_u > 6$

Sands and gravels not meeting the above requirements are poorly-graded or uniformly-graded.

C<sub>c</sub> and C<sub>u</sub> are not applicable for the description of soils with more than 10% silt and clay (more than 10% finer than 0.075 mm or the #200 sieve)

### CONSOLIDATION TEST

p' <sub>o</sub>	-	Present effective overburden pressure at sample depth
p' <sub>c</sub>	-	Preconsolidation pressure of (maximum past pressure on) sample
C <sub>cr</sub>	-	Recompression index (in effect at pressures below p' <sub>c</sub> )
C <sub>c</sub>	-	Compression index (in effect at pressures above p' <sub>c</sub> )
OC Ratio		Overconsolidation ratio = $p'_c / p'_o$
Void Ratio		Initial sample void ratio = volume of voids / volume of solids
W <sub>o</sub>	-	Initial water content (at start of consolidation test)

### PERMEABILITY TEST

k	-	Coefficient of permeability or hydraulic conductivity is a measure of the ability of water to flow through the sample. The value of k is measured at a specified unit weight for (remoulded) cohesionless soil samples, because its value will vary with the unit weight or density of the sample during the test.
---	---	--

## SYMBOLS AND TERMS (continued)

### STRATA PLOT

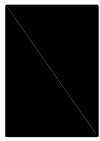

Topsoil

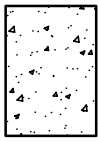

Asphalt

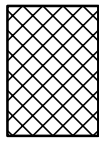

Fill

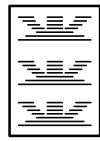

Peat

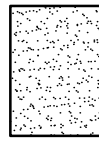

Sand

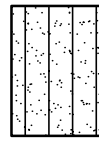

Silty Sand

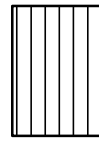

Silt

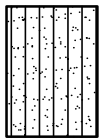

Sandy Silt

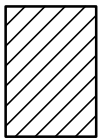

Clay

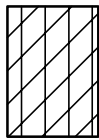

Silty Clay

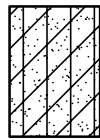

Clayey Silty Sand



Glacial Till

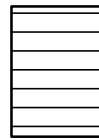

Shale

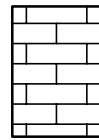

Bedrock

### MONITORING WELL AND PIEZOMETER CONSTRUCTION

#### MONITORING WELL CONSTRUCTION

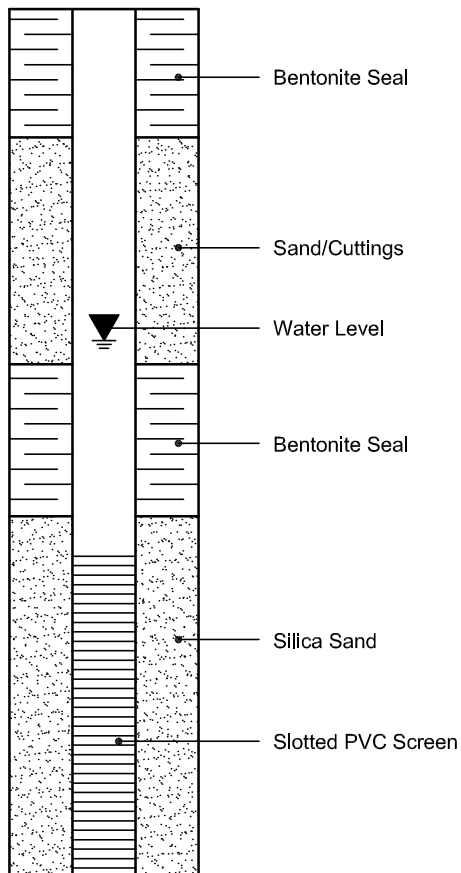

#### PIEZOMETER CONSTRUCTION

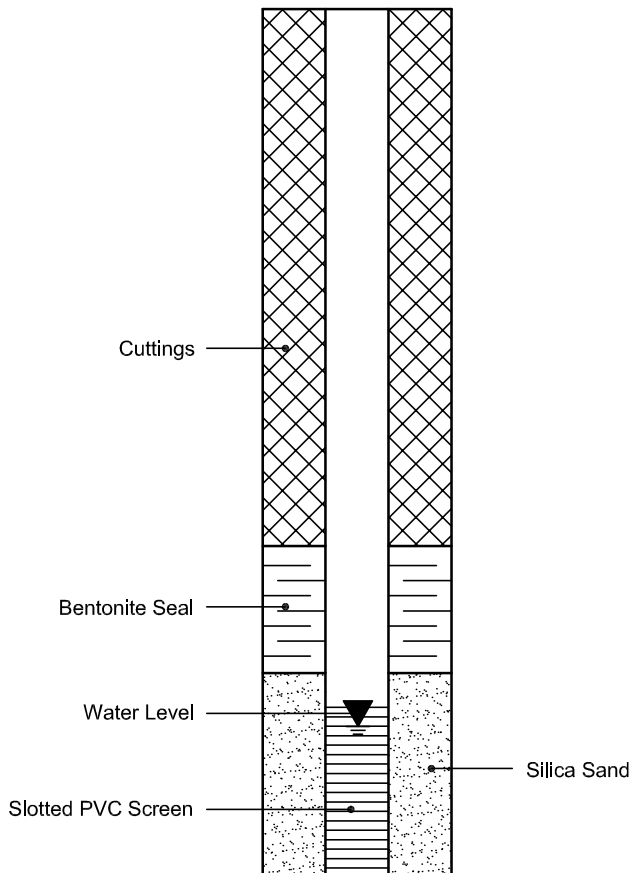

Certificate of Analysis

Report Date: 05-May-2021

Client: Paterson Group Consulting Engineers

Order Date: 30-Apr-2021

Client PO: 31983

Project Description: PG5729

<b>Client ID:</b>	BH 1-21-SS11	-	-	-
<b>Sample Date:</b>	29-Apr-21 09:00	-	-	-
<b>Sample ID:</b>	2118595-01	-	-	-
<b>MDL/Units</b>	Soil	-	-	-

**Physical Characteristics**

% Solids	0.1 % by Wt.	91.8	-	-	-
----------	--------------	------	---	---	---

**General Inorganics**

pH	0.05 pH Units	7.99	-	-	-
Resistivity	0.10 Ohm.m	143	-	-	-

**Anions**

Chloride	5 ug/g dry	18	-	-	-
Sulphate	5 ug/g dry	<5	-	-	-

# **APPENDIX 2**

**FIGURE 1 - KEY PLAN**

**FIGURE 2 - AERIAL PHOTOGRAPH - 1965**

**FIGURE 3 - AERIAL PHOTOGRAPH - 2019**

**DRAWING PG5729-1 - TEST HOLE LOCATION PLAN**







## FIGURE 2

AERIAL PHOTOGRAPH - 1965

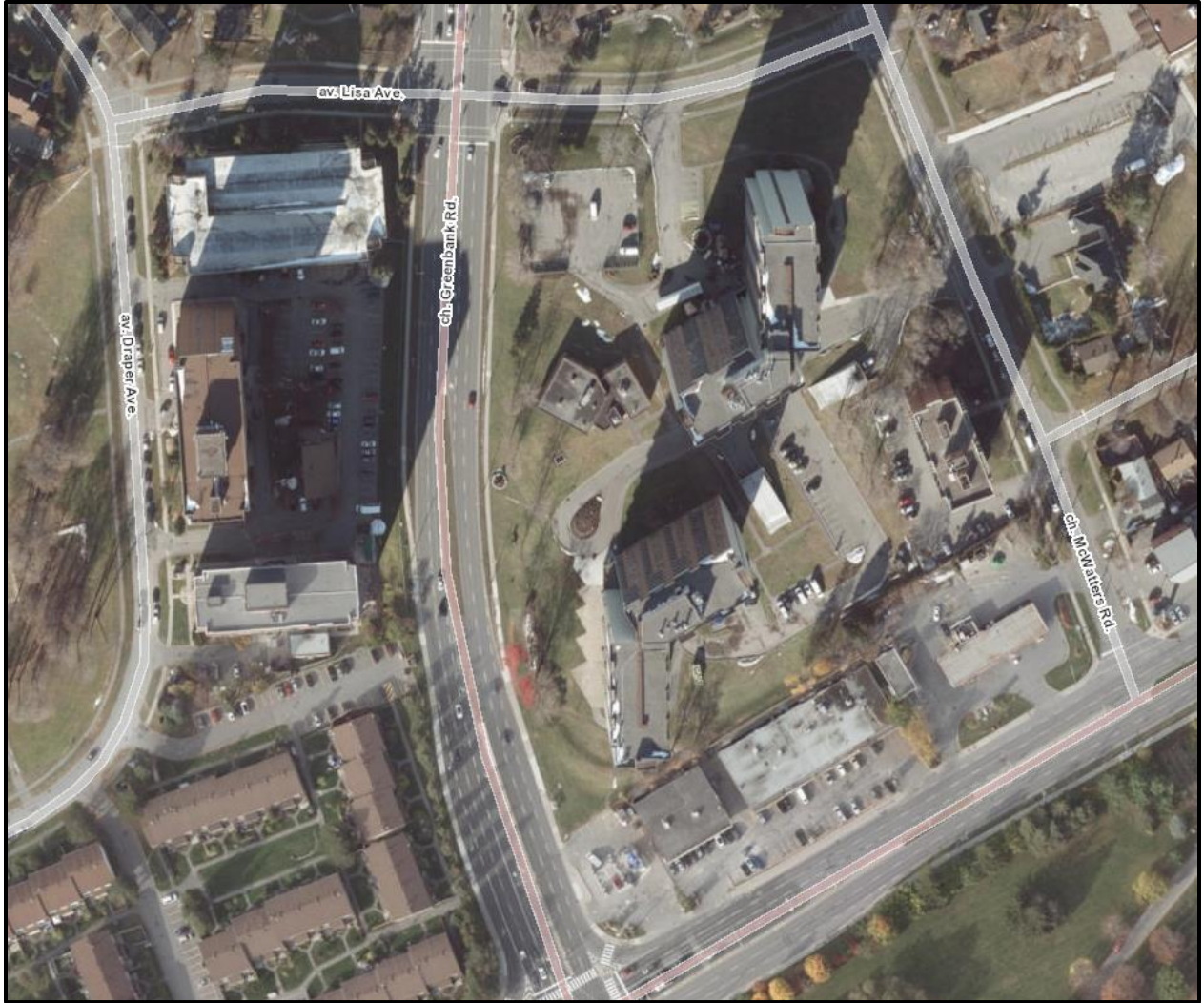

## FIGURE 3

AERIAL PHOTOGRAPH - 2019

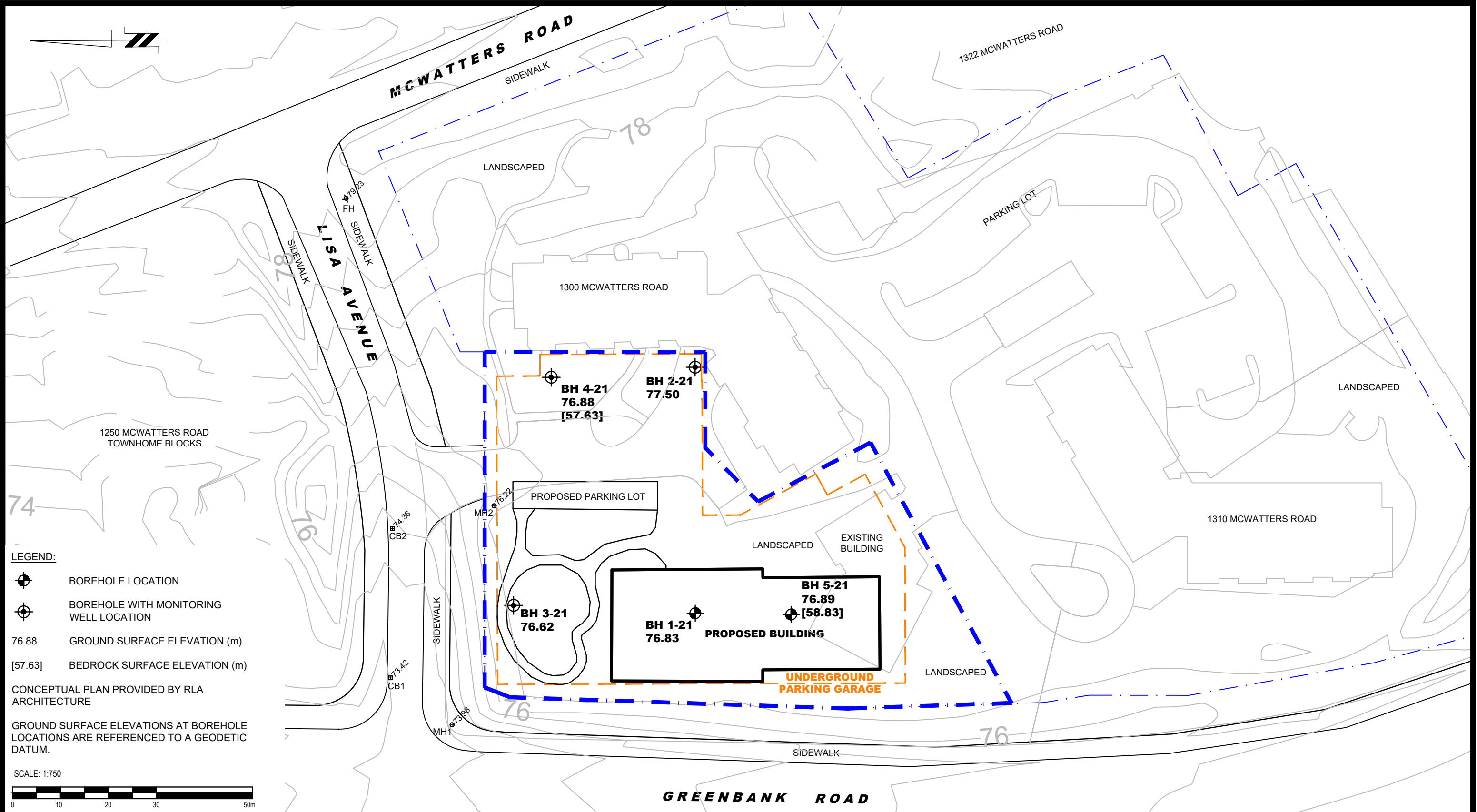

**patersongroup**  
consulting engineers

154 Colonnade Road South  
Ottawa, Ontario K2E 7J5  
Tel: (613) 226-7381 Fax: (613) 226-6344

NO.	REVISIONS	DATE	INITIAL

HOMESTEAD LAND HOLDINGS LIMITED  
GEOTECHNICAL INVESTIGATION  
PROPOSED MULTI-STOREY BUILDING  
1300 AND 1310 MCWATTERS ROAD  
ONTARIO

OTTAWA,  
Title:

**TEST HOLE LOCATION PLAN**

Scale:	1:750	Date:	05/2021
Drawn by:	YA	Report No.:	PG5729-1
Checked by:	KP	Dwg. No.:	<b>PG5729-1</b>
Approved by:	SD	Revision No.:	

p:\autocad\drawings\geotechnical\pg5729\pg5729-1-test hole location plan.dwg

Drawings

**Appendix F DRAWINGS**

