

LEGEND

CONCRETE BARRIER CURB	PROPERTY LINE
CONCRETE WALKWAY	DRAINAGE SWALE
PROPOSED LIGHT DUTY ASPHALT	DRAINAGE DITCH
PROPOSED HEAVY DUTY ASPHALT	SLOPING AT 3:1 UNLESS SPECIFIED
INSULATION PER W22	SURFACE ELEVATION
MHH# 1/5	SWALE ELEVATION
CBMH# 1/5	TOP OF WALL ELEVATION
CBH# 1/5	BOTTOM OF WALL ELEVATION
MHH# 1/5	OVERLAND FLOW ROUTE
HYD B/F	SILT FENCE BARRIER
WATER VALVE	EXISTING BUILDING WALL
WATER METER	STRAW BALE CHECK DAM
REMOTE WATER METER	PROPOSED PLAY AREA
	EXISTING SEWER
	PROPOSED SEWER
	LIMIT OF WORK

FOR REVIEW ONLY
 NOT FOR CONSTRUCTION

1	ISSUED FOR REVIEW	FEB. 01, 2022
No.	Revisions	Date

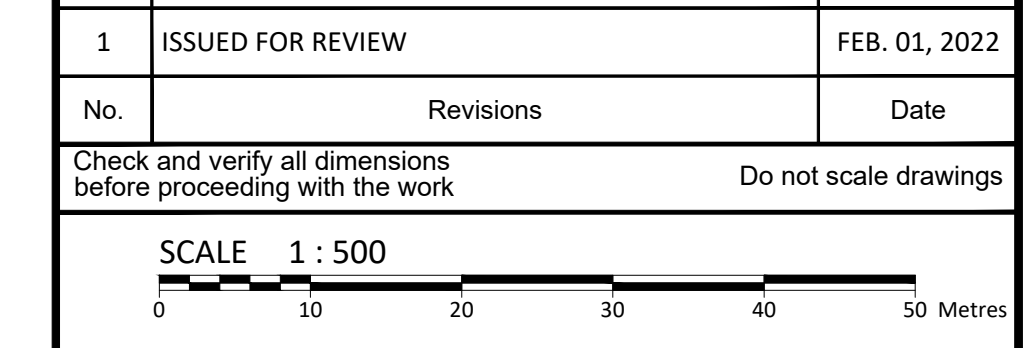

McINTOSH PERRY
 115 Walgreen Road, RR3, Carp, ON K0A 1L0
 Tel: 613-836-2184 Fax: 613-836-3742
 www.mcintoshperry.com

Client: **FIGUR ARCHITECTS COLLECTIVE**
 190 SOMERSET STREET WEST
 OTTAWA, ON K2P 0J4
 (613) 695-6122

Project: **1633/1635 LYCEE PLACE**
 OTTAWA, ON K1G 0E5
 613-733-8522

Drawing Title: **Detail Sheet 1**

Scale: 1:500 Project Number: CCO-22-1100

Drawn By: N.V. Drawing Number: Detail Sheet 1

Checked By: R.F.

Designed By: N.V.

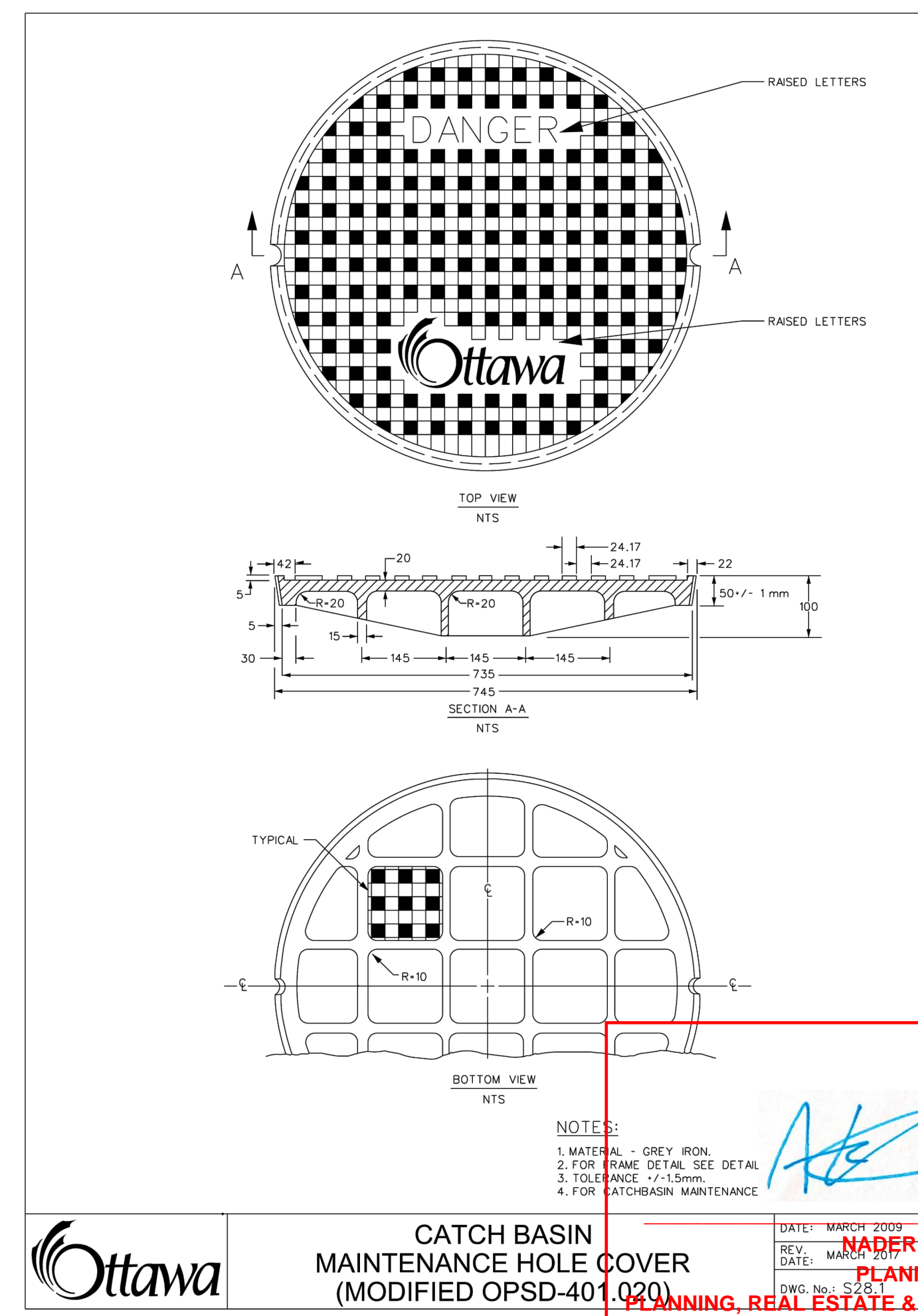
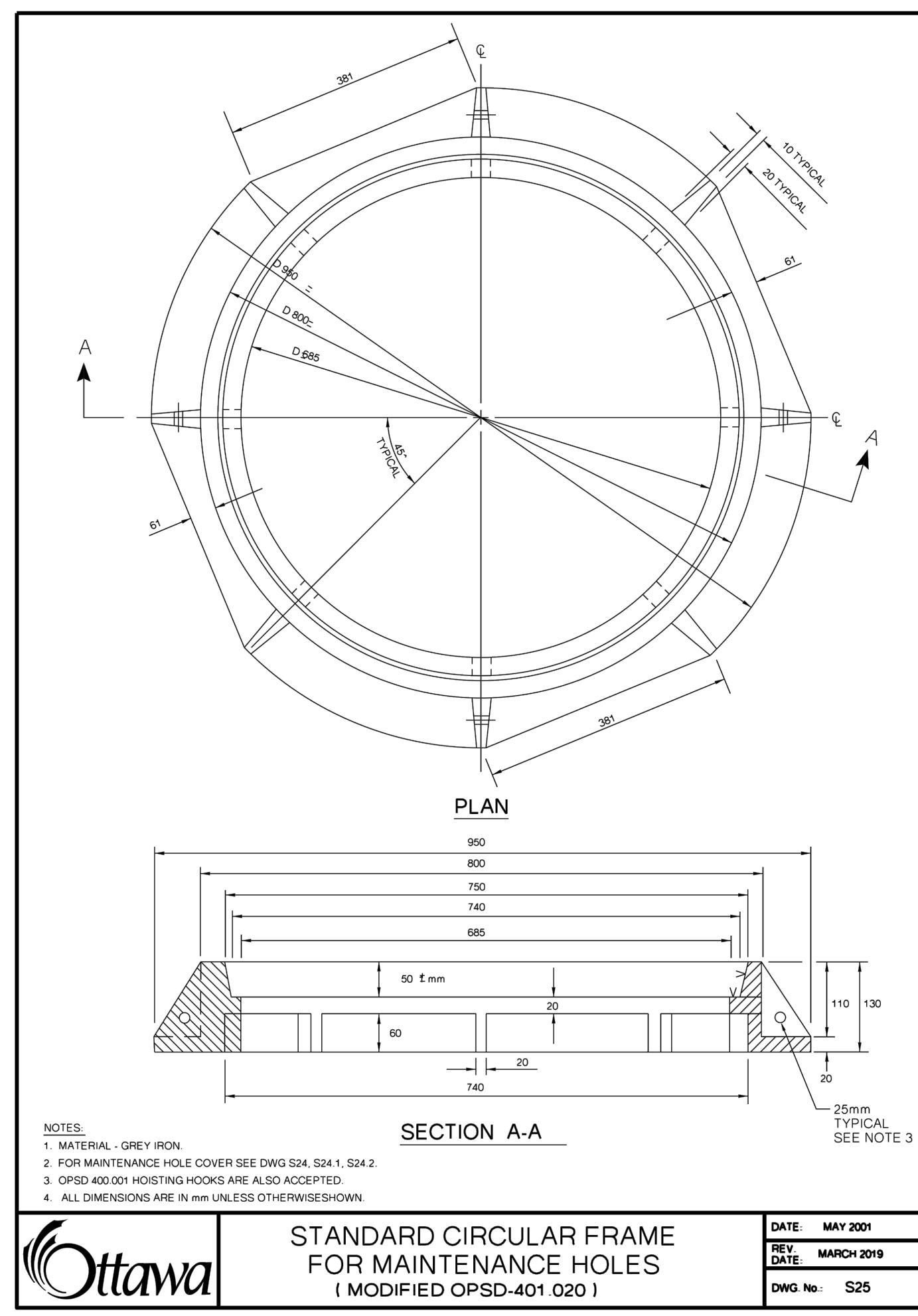
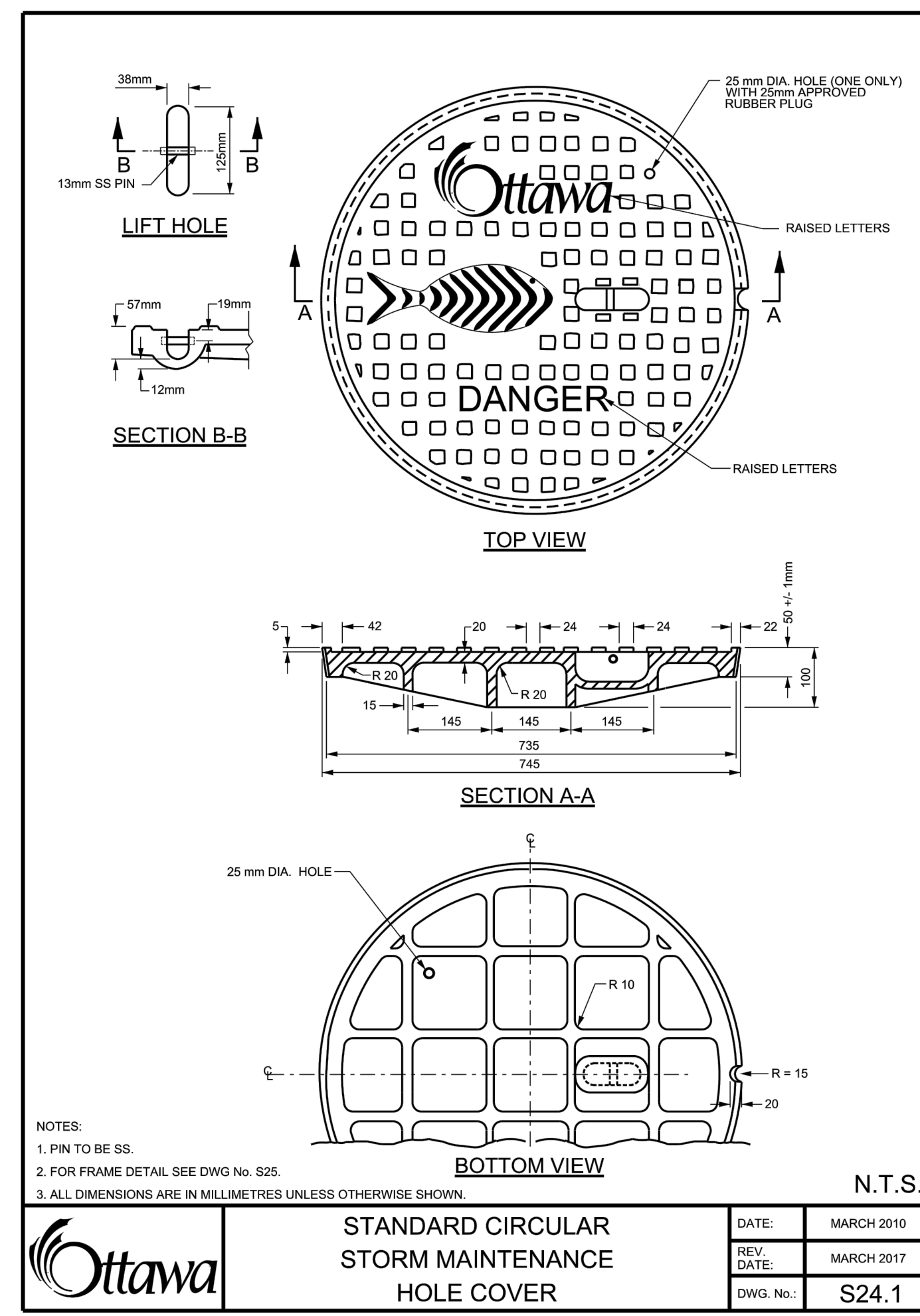

MADER KADRI
 PLANNER II
 PLANNING, REAL ESTATE & ECONOMIC DEVELOPMENT
 DEPARTMENT, CITY OF OTTAWA

FILENAME: C:\City\GIS\Projects\Projects\2022\CCO-22-1100\CCO-22-1100_Presentation.dwg
 LAST SAVED: Tuesday, May 10, 2022 1:51:54 PM BY: F. Mahani
 LAST PLOTTED: Tuesday, May 10, 2022 2:15:10 PM FILE USED: ...

D07-12-22-0022