

SERVICING & STORMWATER MANAGEMENT REPORT SCHLEGEL VILLAGES – 1919 RIVERSIDE DRIVE

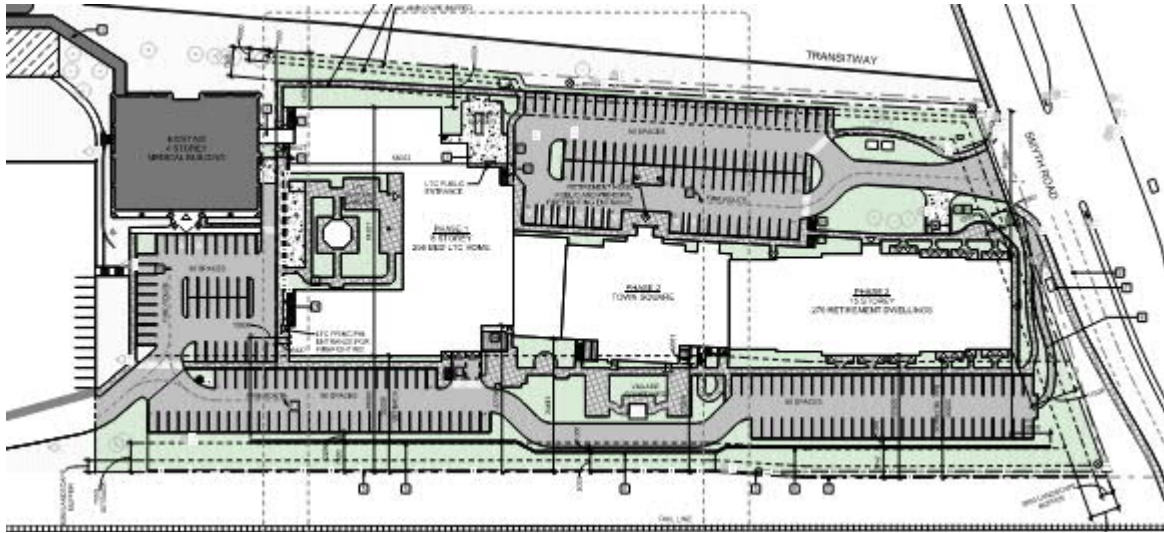

Project No.: CCO-21-2955

City File No.: D07-12-21-0170

Prepared for:

RBJ Schlegel Holdings
325 Max Becker Drive, Suite 201
Kitchener, ON N2E 4H5

Prepared by:

McIntosh Perry Consulting Engineers Ltd.
115 Walgreen Road
Carp, ON K0A 1L0

April 8th, 2022

TABLE OF CONTENTS

1.0	PROJECT DESCRIPTION.....	1
1.1	Purpose.....	1
1.2	Site Description.....	1
1.3	Proposed Development and Statistics.....	2
1.4	Existing Conditions and Infrastructures.....	2
1.5	Approvals.....	3
2.0	BACKGROUND STUDIES, STANDARDS, AND REFERENCES.....	4
2.1	Background Reports / Reference Information.....	4
2.2	Applicable Guidelines and Standards.....	4
3.0	PRE-CONSULTATION SUMMARY.....	5
4.0	WATERMAIN.....	6
4.1	Existing Watermain.....	6
4.2	Proposed Watermain.....	6
4.3	Water Model Results.....	8
5.0	SANITARY DESIGN.....	9
5.1	Existing Sanitary Sewer.....	9
5.2	Proposed Sanitary Sewer.....	9
6.0	STORM SEWER DESIGN.....	11
6.1	Existing Storm Sewers.....	11
6.2	Proposed Storm Sewers.....	11
7.0	PROPOSED STORMWATER MANAGEMENT.....	13
7.1	Design Criteria and Methodology.....	13
7.2	Runoff Calculations.....	13
7.3	Pre-Development Drainage.....	14
7.4	Post-Development Drainage.....	14
8.0	EROSION AND SEDIMENT CONTROL.....	16
8.1	Temporary Measures.....	16
8.2	Permanent Measures.....	16
9.0	SUMMARY.....	17
10.0	RECOMMENDATION.....	18
11.0	STATEMENT OF LIMITATIONS.....	19

LIST OF TABLES

Table 1: Water Supply Design Criteria and Water Demands	7
Table 2: Boundary Conditions Results	7
Table 3: Fire Protection Confirmation.....	8
Table 4: Water Pressure at Junctions.....	8
Table 5: Sanitary Design Criteria.....	9
Table 6: Summary of Estimated Sanitary Flow	10
Table 7: Pre-Development Runoff Summary.....	14
Table 8: Post-Development Runoff Summary	14

APPENDICES

Appendix A: Site Location Plan

Appendix B: Background Documents

Appendix C: Watermain Calculations

Appendix D: Sanitary Calculations

Appendix E: Pre-Development Drainage Plan

Appendix F: Post-Development Drainage Plan

Appendix G: Stormwater Management Calculations

Appendix H: City of Ottawa Design Checklist

1.0 PROJECT DESCRIPTION

1.1 Purpose

McIntosh Perry (MP) has been retained by RBJ Schlegel Holdings to prepare this Servicing and Stormwater Management Report in support of the Site Plan Control process for the proposed development located at 1919 Riverside Drive within the City of Ottawa.

The main purpose of this report is to present a servicing and stormwater management design for the development in accordance with the recommendations and guidelines provided by the City of Ottawa (City), the Rideau Valley Conservation Authority (RVCA), and the Ministry of the Environment, Conservation and Parks (MECP). This report will address the water, sanitary and storm sewer servicing for the development, ensuring that existing and available services will adequately service the proposed development.

This report should be read in conjunction with the following drawings:

- CCO-21-2955, C101 – Site Grading and Drainage Plan
- CCO-21-2955, C102 – Site Servicing Plan
- CCO-21-2955, C103 – Sediment and Erosion Control Plan
- CCO-21-2955, PRE – Pre-Development Drainage Area Plan (Appendix 'E')
- CCO-21-2955, POST – Post Development Drainage Area Plan (Appendix 'F')

1.2 Site Description



Figure 1: Site Map

The subject property, herein referred to as the site, is located at 1919 Riverside Drive within the Alta Vista Ward. The site covers approximately 8.48 ha and is located at the intersection of Smyth Road and Riverside Drive. The site is zoned for Major Institutional use (I2). See Site Location Plan in Appendix 'A' for more details.

1.3 Proposed Development and Statistics

The proposed development consists of a long-term care facility and retirement residence. The long-term care facility proposes to contain 256 beds with 85 staff and the retirement residence proposes to contain 270 units with 60 staff. Drive aisles will be provided throughout the site with access from the Smyth Road and from the existing parking lot. Parking will be provided via underground and aboveground parking lots. Development is proposed within 2.13 ha of the site. Refer to Site Plan prepared by CSV Architects and included in Appendix 'B' for further details.

1.4 Existing Conditions and Infrastructures

The site is currently developed containing several parking lots and two medical buildings. Sanitary, water, and storm services exist within the parking area and will be removed or relocated to accommodate the proposed development.

Sewer and watermain mapping collected from the City of Ottawa indicate that the following services exist across the property frontages within the adjacent municipal rights-of-way(s) and within the subject site:

- ❖ Smyth Road
 - 1050 mm diameter concrete storm sewer tributary to the Rideau River approximately 310 m downstream.
- ❖ Subject Site (98m south of Smyth Road)
 - 254 mm diameter unlined cast iron watermain, and a
 - 675 mm diameter concrete sanitary sewer tributary to the Rideau River collector.
- ❖ Transitway
 - 203 mm diameter watermain,
 - 1350-1500 mm diameter Rideau River collector sanitary trunk sewer, and a
 - 375 mm diameter concrete storm sewer tributary to the Rideau River approximately 520 m downstream.

1.5 Approvals

The proposed development is subject to the City of Ottawa site plan control approval process. Site plan control requires the City to review, provide concurrence and approve the engineering design package. Permits to construct can be requested once the City has issued a site plan agreement.

An Environmental Compliance Approval (ECA) through the Ministry of Environment, Conservation and Parks (MECP) is anticipated to be required for the sanitary sewer realignment under the Transfer of Review process. Requirement to be confirmed by City of Ottawa staff.

2.0 BACKGROUND STUDIES, STANDARDS, AND REFERENCES

2.1 Background Reports / Reference Information

As-built drawings of existing services, provided by the City of Ottawa Information centre, within the vicinity of the proposed site were reviewed in order to identify infrastructure available to service the proposed development.

A topographic survey (21319-20) of the site was completed by Annis, O’Sullivan, Vollebekk Ltd and dated December 18th, 2020.

The Site Plan (A1.02) was prepared by CSV Architects and dated October 21st, 2021 (Site Plan).

2.2 Applicable Guidelines and Standards

City of Ottawa:

- ◆ Ottawa Sewer Design Guidelines, City of Ottawa, SDG002, October 2012. (Ottawa Sewer Guidelines)
 - Technical Bulletin ISTB-2014-01 City of Ottawa, February 2014. (ISTB-2014-01)
 - Technical Bulletin PIEDTB-2016-01 City of Ottawa, September 2016. (PIEDTB-2016-01)
 - Technical Bulletin ISTB-2018-01 City of Ottawa, January 2018. (ISTB-2018-01)
 - Technical Bulletin ISTB-2018-03 City of Ottawa, March 2018. (ISTB-2018-03)
 - Technical Bulletin ISTB-2019-01 City of Ottawa, January 2019. (ISTB-2019-01)
 - Technical Bulletin ISTB-2019-02 City of Ottawa, February 2019. (ISTB-2019-02)
- ◆ Ottawa Design Guidelines – Water Distribution City of Ottawa, July 2010. (Ottawa Water Guidelines)
 - Technical Bulletin ISD-2010-2 City of Ottawa, December 15, 2010. (ISD-2010-2)
 - Technical Bulletin ISDTB-2014-02 City of Ottawa, May 2014. (ISDTB-2014-02)
 - Technical Bulletin ISTB-2018-02 City of Ottawa, March 2018. (ISTB-2018-02)

Ministry of Environment, Conservation and Parks:

- ◆ Stormwater Planning and Design Manual, Ministry of the Environment, March 2003. (MECP Stormwater Design Manual)
- ◆ Design Guidelines for Sewage Works, Ministry of the Environment, 2008. (MECP Sewer Design Guidelines)

3.0 PRE-CONSULTATION SUMMARY

A pre-consultation email was provided by City staff on April 29th, 2021 regarding the proposed development and site servicing. Specific design parameters to be incorporated within this design include the following:

- Pre-development and post-development flows shall be calculated using a time of concentration (T_c) greater than 10 minutes.
- Control 5 through 100-year post-development flows to the 5-year storm event, based on a rational method coefficient of 0.5 and calculated time of concentration.
- Quality control are to be confirmed by the RVCA due to the site's distance from the outlet. No response was received prior to publication.

4.0 WATERMAIN

4.1 Existing Watermain

The site is located within the 1E pressure zone, as per the Water Distribution System figure included in Appendix C. There is an existing 254 mm diameter unlined cast iron watermain running within the development area through the existing parking lot.

4.2 Proposed Watermain

In accordance with Section 4.3.1 of the Ottawa Water Guidelines, service areas with a basic day demand greater than 50 m³/day require a dual connection to the municipal system. A dual connection to the 254 mm diameter watermain at the east of the site and to the existing 200 mm watermain west of the site is proposed to service the development.

It is proposed to connect a 200mm diameter water service to the 200 mm watermain west of the site with water valves at the property line. The existing 250 mm watermain is proposed to be relocated around the subject site, connecting to the existing 200 mm watermain within Smyth Road. Three private hydrants have been proposed within the site. The watermain is designed to have a minimum of 2.4 m cover. Refer to drawing C102 for a detailed servicing layout.

The 203 mm diameter watermain network servicing the existing medical buildings will remain as part of this development. In addition, existing fire hydrants within the site will be retained therefore there is no anticipated impact to the fire servicing for the existing development.

The Fire Underwriters Survey 1999 (FUS) method was utilized to estimate the required fire flow for the site. Fire flow requirements were calculated per City of Ottawa Technical Bulletin ISTB-2018-02. The following parameters were coordinated with the architect.

- ❖ Type of construction – Non-Combustible Construction
- ❖ Occupancy Type – Limited Combustibility
- ❖ Sprinkler Protection – Supervised Sprinkler System

The results of the calculations yielded a required fire flow of 23,000 L/min (383.33 L/s). The detailed calculations for the FUS can be found in Appendix C.

The water demands for the proposed building have been calculated to adhere to the Ottawa Water Guidelines and can be found in Appendix C. The results have been summarized below:

Table 1: Water Supply Design Criteria and Water Demands

Site Area	2.013 ha
Nursing Homes & Rest Homes	450 L/bed/day
Medical Office – Doctors, Nurses & Medical Staff	275 L/person/day
Maximum Daily Peaking Factor	1.5 x avg day
Maximum Hour Peaking Factor	1.8 x avg day
Average Day Demand (L/s)	3.20
Maximum Daily Demand (L/s)	4.80
Peak Hourly Demand (L/s)	8.64
FUS Fire Flow Requirement (L/s)	383.33 (23,000 L/min)

The City provided the estimated water pressures at both for the average day scenario, peak hour scenario and the max day plus fire flow scenario for the demands indicated by the correspondence in Appendix C. The resulting pressures for the boundary conditions results are shown in Table 2, below.

Table 2: Boundary Conditions Results

Scenario	Proposed Demands (L/S)	Connection 1 HGL (m H ₂ O)* /kPa	Connection 2 HGL (m H ₂ O)* /kPa
Average Day Demand	3.20	53.1 / 520.9	49.6 / 486.6
Maximum Daily + Fire Flow Demand	388.13	147 L/s available at 20 psi (140 kPa)	
Peak Hourly Demand	8.64	41.8 / 410.1	38.3 / 375.7
*Adjusted for an estimated ground elevation of 65.8 m at Connection 1 and 69.3 m at Connection 69.3m above the connection point for connection.			

To confirm the adequacy of fire flow to protect the proposed development, public and private fire hydrants within 150 m of the proposed building were analysed per City of Ottawa ISTB 2018-02 Appendix I Table 1. The results are summarized below.

Table 3: Fire Protection Confirmation

Building	Fire Flow Demand (L/min.)	Fire Hydrant(s) within 75m	Fire Hydrant(s) within 150m	Combined Fire Flow (L/min.)
1919 Riverside	23,000	1 private (existing) 3 private (proposed) 1 public (proposed)	1 private (existing)	32,300

Based on City guidelines (ISTB-2018-02), the existing and proposed hydrants can provide adequate fire coverage to the proposed development.

4.3 Water Model Results

A water model was completed using the EPANet modelling software and the boundary condition results provided and noted above. The results determined that the relocated 250 mm watermain can adequately service the proposed development and provide sufficient fire flow. The model determined pressures during average day, maximum day plus fire flow, and peak hour demands. The model results identify the estimated pressures at the building finished floors and at fire hydrants during fire flow conditions. For the purposes of determining fire flow, 127.8 L/s (7,668 L/min) at each internal hydrant was assumed, totalling 383.33 L/s (23,000 L/min).

Table 4: Water Pressure at Junctions

Junction	Average Day (kPa)	Peak Hourly (kPa)	Max. Day + Fire Flow (kPa)
J3	548.35	381.18	437.36
J4	567.66	447.76	456.87
J5	507.85	391.28	397.07
PROP	543.84	376.58	432.56
FH3	544.82	224.42	433.83
FH4	522.56	242.16	411.77
FH5	564.23	272.46	453.44

The normal operating pressure range is anticipated to be 397 kPa to 567.7 kPa and will not be less than 275 kPa (40 psi) or exceed 689 kPa (100 psi). The proposed watermain will meet the minimum required 20 psi (140 kPa) at the ground level under maximum day demand and fire flow conditions.

5.0 SANITARY DESIGN

5.1 Existing Sanitary Sewer

There is an existing 1350-1500 mm diameter concrete sanitary trunk sewer (the Rideau River Collector sewer) within the transitway, fronting the west edge of the site. In addition, there is an existing 675 mm diameter sanitary sewer running through the subject site. The site currently contributes wastewater to the Rideau River collector sewer via the existing 675 mm diameter sanitary sewer.

5.2 Proposed Sanitary Sewer

An internal sanitary sewer network is proposed to service the development. As shown by drawing C102, the development will be serviced via the existing 675 mm diameter sanitary sewer within the western parking lot and by the realigned 675 mm diameter sanitary sewer within the eastern parking lot.

Table 5, below, summarizes the wastewater design criteria identified by the Ottawa Sewer Guidelines.

Table 5: Sanitary Design Criteria

Design Parameter	Value
Site Area	2.013 ha
Nursing Homes & Rest Homes	450 L/bed/day
Medical Office – Doctors, Nurses & Medical Staff	275 L/person/day
Institutional Peaking Factor	1.5

Table 6, below, summarizes the estimated wastewater flow from the proposed development. Refer to Appendix 'D' for detailed calculations.

Table 6: Summary of Estimated Sanitary Flow

Design Parameter	Total Flow (L/s)
Total Estimated Average Dry Weather Flow	3.30
Total Estimated Peak Dry Weather Flow	4.90
Total Estimated Peak Wet Weather Flow	5.47

As noted above, the development is proposed to be serviced via the existing sanitary sewers, directly connected to the Rideau River Collector sewer. Due to the complexity of the downstream network the City will need to advise of any downstream constraints.

The existing 675 mm diameter sanitary sewer crossing through the site is situated at a 1.2-1.5% slope. Based on Balmoral Place as built (Contact No. 89-17, Plan No. 2185), the 675 mm sanitary sewer is situated at a 0.62-0.90% slope. Based on the diameter and slope of the constraining leg of sanitary sewer, the estimated capacity is 209.3 L/s. As shown by drawing C102, the 675 mm diameter sanitary sewer is proposed to be realigned at a minimum 0.1% slope in accordance with Section 6.1.2.2 of the Sewer Design Guidelines. Therefore, it is estimated that the future capacity of the sewer is 265.8 L/s, improving existing conditions while respecting scouring velocities.

6.0 STORM SEWER DESIGN

6.1 Existing Storm Sewers

Stormwater runoff from the site is currently tributary to the Rideau River within the Ottawa Central sub-watershed. There are three existing stormwater outlets for the subject site:

- The first collects drainage within the western parking lot via a catch basin system. Drainage is collected and directed to the 1050 mm diameter storm sewer within Smyth Road via a 200 mm service. Stormwater drainage is conveyed to the Rideau River (outlet OUT04494) approximately 210 m downstream, herein referred to as Outlet 1.
- The second collects drainage east of the existing medical buildings and within the central drive aisles via a catch basin system. Drainage is collected and directed to the existing 675 mm diameter storm sewer within the Transitway via a 375 mm diameter storm sewer. Stormwater drainage is conveyed to the Rideau River (outlet OUT04495) approximately 240 m downstream, herein referred to as Outlet 2.
- The third collects drainage within the southern parking lot via a catch basin system. Drainage is collected and directed to the 1200 mm diameter storm sewer at the south end of the site. Stormwater drainage is conveyed to the Rideau River (outlet OUT04345) approximately 234 m downstream. No changes to this outlet and system will be proposed as part of this development.

6.2 Proposed Storm Sewers

The existing 200 mm diameter storm sewer network in the western parking area is proposed to be realigned and increased in diameter. The sewer system will provide flow attenuation for the parking lot and landscaped areas via storm maintenance structure CBMH1. This storm sewer system is tributary to Outlet 1, noted in Section 6.1 above.

The existing 375 mm diameter storm sewer network in the eastern parking area is proposed to be realigned. The storm sewer system will provide flow attenuation for the parking lots, courtyard, and garden via storm maintenance structure MH5 and CB12. This storm sewer system is tributary to Outlet 2, noted in Section 6.1 above, and will contain an OGS unit.

Runoff collected on the roof of the proposed building will be stored and controlled internally using twenty-four roof drains. Roof drains will be used to limit the flow from the roof to the specified allowable release rate. For calculation purposes a Watts Accutrol roof drain was used estimate a reasonable roof flow. Other products maybe specified at detailed building design so long as release rates and storage volumes are respected. Drainage from the roof will be directed towards Outlet 1 via storm maintenance structure OGS.

Foundation drainage is proposed to be conveyed to the Smyth Road outlet via the 300 mm storm services connected at the west end of the building. No flow controls are proposed downstream of the foundation drainage.

See CCO-21-2955 - POST include in Appendix F of this report for more details. The Stormwater Management design for the subject property will be outlined in Section 7.0 of this report.

7.0 PROPOSED STORMWATER MANAGEMENT

7.1 Design Criteria and Methodology

Stormwater management for the proposed site will be maintained through two methods. The first will store and control runoff collected on the roof of the proposed buildings. It is estimated that twenty-four Watts Accutrol Weirs will be used to control the release rate of the stormwater. The second will control stormwater via an underground sewer system and will collect runoff from the at-grade areas within the site.

In summary, the following design criteria have been employed in developing the stormwater management design for the site as directed by the City:

Quality Control

- Quality controls are to be confirmed by the RVCA however, it is anticipated that quality controls will be required on the Smyth Road outlet due to the distance to the Rideau River.

Quantity Control

- Pre-development and post-development flows shall be calculated using a time of concentration (T_c) greater than 10 minutes.
- Control 5 through 100-year post-development flows to the 5-year storm event, based on a rational method coefficient of 0.5 and calculated time of concentration. Refer to Section 7.2 for further details.

7.2 Runoff Calculations

Runoff calculations presented in this report are derived using the Rational Method, given as:

$$Q = 2.78CIA \text{ (L/s)}$$

Where:	C	= Runoff coefficient
	I	= Rainfall intensity in mm/hr (City of Ottawa IDF curves)
	A	= Drainage area in hectares

It is recognized that the Rational Method tends to overestimate runoff rates. As a result, the conservative calculation of runoff ensures that any SWM facility sized using this method is expected to function as intended. The following coefficients were used to develop an average C for each area:

Roofs/Concrete/Asphalt	0.90
Undeveloped and Grass	0.20

As per the City of Ottawa - Sewer Design Guidelines, the 5-year balanced 'C' value must be increased by 25% for a 100-year storm event to a maximum of 1.0.

7.3 Pre-Development Drainage

It has been assumed that the existing development contained no stormwater management controls for flow attenuation. The estimated pre-development peak flows for the 2, 5, and 100-year events are summarized below in Table 7. See CCO-21-2955 - PRE in Appendix E and Appendix G for calculations.

Table 7: Pre-Development Runoff Summary

Drainage Area	Area (ha)	Q (L/s)	
		5-Year	100-Year
A1	2.131	434.37	835.34

7.4 Post-Development Drainage

To meet the stormwater objectives the development will contain a combination of flow attenuation with rooftop controls and surface storage.

Based on the criteria listed in Section 7.1, the development will be required to restrict flow to the 5-year storm event. It is estimated that the target release rate during the 100-year event will be 308.6 L/s. See Appendix G for calculations.

The proposed site drainage limits are demonstrated on the Post-Development Drainage Area Plan. See CCO-21-2955 - POST in Appendix F of this report for more details. A summary of the post-development runoff calculations can be found below.

Table 8: Post-Development Runoff Summary

Drainage Area	Area (ha)	5-year Peak Flow (L/s)	100-year Peak Flow (L/s)	100-year Storage Required (m ³)	100-year Storage Available (m ³)
B1	0.246	5.50	10.45	99.94	101.91
B2	0.340	3.99	7.49	167.96	179.79
B3	0.355	81.67	108.88	28.43	29.18
B4	0.090	9.35	18.76	-	-
B5	0.168	20.31	20.61	38.27	42.68
B6	0.192	34.70	35.19	104.45	107.73
B7	0.141				
B8	0.089				
B9	0.189				
B10	0.327	44.16	86.88	-	-
Total	2.135	199.68	288.26	439.04	461.29

Runoff for area B1 will be stored on the roof of the retirement residence (B1) and restricted using ten Watts Accutrol roof drains (or equivalent product) to a maximum release rate of 10.45 L/s and will provide up to 101.91 m³ of storage. Stormwater drainage will be directed to Outlet 1.

Runoff for area B2 will be stored on the roof of the long-term care facility (B2) and restricted using fourteen Watts Accutrol roof drains (or equivalent product) to a maximum release rate of 7.49 L/s and will provide up to 179.8 m³ of storage. Stormwater drainage will be directed to Outlet 1.

Runoff for area B3 will be restricted before discharging to the existing storm system within Smyth Road. The flow will be controlled within a catch basin maintenance structure (CBMH3) installed with a 179 mm plug style ICD. Drainage from Area B3 will be controlled to a maximum release rate of 108.9 L/s and will provide up to 29.2 m³ of surface storage. Stormwater drainage will be directed to Outlet 1.

Runoff for area B4 will be unrestricted before discharging to the existing 375 mm diameter storm sewer system. Runoff will be compensated for in areas with attenuation. Stormwater drainage will be directed to Outlet 2.

Runoff for area B5 will be restricted before discharging to the existing 375 mm diameter storm system. The flow will be controlled within a catch basin (CB4) installed with a 75 mm plug style ICD. Drainage from Area B5 will be controlled to a maximum release rate of 20.6 L/s and will provide up to 42.7 m³ of surface storage. Stormwater drainage will be directed to Outlet 2.

Runoff for area B6-B9 will be restricted before discharging to the existing 375 mm diameter storm system. The flow will be controlled within a maintenance structure (MH6) installed with a 100 mm plug style ICD. Drainage from Area B6-B9 will be controlled to a maximum release rate of 35.2 L/s and will provide up to 107.7 m³ of surface storage. Stormwater drainage will be directed to Outlet 2.

The flow from Area B10 will be directed to the City's right of ways (Smyth Road) without restriction and will be compensated or in areas with attenuation.

As per drawing C102, a Hydro International FD-3HC oil & grit separator or an approved equivalent is proposed to be installed at the downstream end of the Smyth Road storm sewer system (to Outlet 1). The oil & grit separator structure will provide an enhanced level of treatment (80% TSS removal) for the rooftop, foundation, and parking lot drainage.

As per drawing C102, a Hydro International FD-3HC oil & grit separator or an approved equivalent is proposed to be installed at the downstream end of the eastern/southern storm sewer system (to Outlet 2). The oil & grit separator structure will provide an enhanced level of treatment (80% TSS removal) for the parking lot drainage.

8.0 EROSION AND SEDIMENT CONTROL

8.1 Temporary Measures

Before construction begins, temporary silt fence, straw bale or rock flow check dams will be installed at all-natural runoff outlets from the property. It is crucial that these controls be maintained throughout construction and inspection of sediment and erosion control will be facilitated by the Contractor or Contract Administration staff throughout the construction period.

Silt fences will be installed where shown on the final engineering plans, specifically along the downstream property limits. The Contractor, at their discretion or at the instruction of the City, Conservation Authority or the Contract Administrator shall increase the quantity of sediment and erosion controls on-site to ensure that the site is operating as intended and no additional sediment finds its way off site. The rock flow, straw bale & silt fence check dams and barriers shall be inspected weekly and after rainfall events. Care shall be taken to properly remove sediment from the fences and check dams as required. Fibre roll barriers are to be installed at all existing curb inlet catch basins and filter fabric is to be placed under the grates of all existing catch basins and manholes along the frontage of the site and any new structures immediately upon installation. The measures for the existing/proposed structures is to be removed only after all areas have been paved. Care shall be taken at the removal stage to ensure that any silt that has accumulated is properly handled and disposed of. Removal of silt fences without prior removal of the sediments shall not be permitted.

Although not anticipated, work through winter months shall be closely monitored for erosion along sloped areas. Should erosion be noted, the Contractor shall be alerted and shall take all necessary steps to rectify the situation. Should the Contractor's efforts fail at remediating the eroded areas, the Contractor shall contact the City and/or Conservation Authority to review the site conditions and determine the appropriate course of action. As the ground begins to thaw, the Contractor shall place silt fencing at all required locations as soon as ground conditions warrant. Please see the Site Grading, Drainage and Sediment & Erosion Control Plan for additional details regarding the temporary measures to be installed and their appropriate OPSD references.

8.2 Permanent Measures

It is expected that the Contractor will promptly ensure that all disturbed areas receive topsoil and seed/sod and that grass be established as soon as possible. Any areas of excess fill shall be removed or levelled as soon as possible and must be located a sufficient distance from any watercourse to ensure that no sediment is washed out into the watercourse. As the vegetation growth within the site provides a key component to the control of sediment for the site, it must be properly maintained once established. Once the construction is complete, it will be up to the landowner to maintain the vegetation and ensure that the vegetation is not overgrown or impeded by foreign objects.

9.0 SUMMARY

- A new 256-bed long-term care facility and a 270-bed retirement residence is proposed within the northern portion of 1919 Riverside Drive. Development is proposed within 2.13 ha of the site.
- New 200 mm diameter water services will be installed to service the site, connecting to the existing 250 mm diameter watermain east of the site and the 200 mm diameter watermain west of the site.
- The existing 250 mm diameter watermain crossing through the development area is proposed to be re-aligned, as per drawing C102.
- A new sanitary sewer network will be installed within the north-west portion of the site in order to service the development and existing 4-storey medical office building.
- The existing 675 mm diameter sanitary sewer crossing through the development area is proposed to be re-aligned, as per drawing C102.
- The proposed storm sewer, ranging in diameter from 200 mm to 450 mm, will be installed throughout the site and drain to the existing storm sewer outlets.
- Storage for the 5- through 100-year storm events will be provided within the parking lot areas above the proposed storm structures and on the proposed flat roof.
- As per drawing C102, an oil & grit separator is proposed to be installed at the downstream end of the Smyth Road storm sewer system (to Outlet 1) and at the downstream end of the eastern/southern storm sewer system (to Outlet 2). The oil & grit separator structure will provide an enhanced level of treatment (80% TSS removal) for the rooftop, foundation, and parking lot drainage.

10.0 RECOMMENDATION

Based on the information presented in this report, we recommend that City of Ottawa approve this Servicing and Stormwater Management report in support of the proposed development at 1919 Riverside Drive.

This report is respectfully being submitted for approval.

Regards,

McIntosh Perry Consulting Engineers Ltd.



Robert D. Freel, P.Eng.
Senior Project Manager, Land Development
T: 613.714.6174
E: r.freel@mcintoshperry.com

A handwritten signature in cursive script that reads "Alison Gosling".

Alison J. Gosling, P.Eng.
Project Engineer, Land Development
T: 613.714.4629
E: a.gosling@mcintoshperry.com

11.0 STATEMENT OF LIMITATIONS

This report was produced for the exclusive use of RBJ Schlegel Holdings. The purpose of the report is to assess the existing stormwater management system and provide recommendations and designs for the post-construction scenario that are in compliance with the guidelines and standards from the Ministry of the Environment, Parks and Climate Change, City of Ottawa and local approval agencies. McIntosh Perry reviewed the site information and background documents listed in Section 2.0 of this report. While the previous data was reviewed by McIntosh Perry and site visits were performed, no field verification/measures of any information were conducted.







Any use of this review by a third party, or any reliance on decisions made based on it, without a reliance report is the responsibility of such third parties. McIntosh Perry accepts no responsibility for damages, if any, suffered by any third party as a result of decisions or actions made based on this review.

The findings, conclusions and/or recommendations of this report are only valid as of the date of this report. No assurance is made regarding any changes in conditions subsequent to this date. If additional information is discovered or becomes available at a future date, McIntosh Perry should be requested to re-evaluate the conclusions presented in this report, and provide amendments, if required.

**APPENDIX A
KEY PLAN**



LEGEND

-  Site Location
-  Local Road
-  Major Road
-  Railroad
-  Watercourse
-  Waterbody
-  Wooded Area

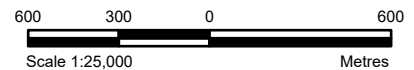

REFERENCE

GIS data provided by the Ontario Ministry of Natural Resources and Forestry, 2021.

CLIENT:
SCHLEGEL VILLAGES OTTAWA

PROJECT:
1919 RIVERSIDE DRIVE, OTTAWA, ON

TITLE:
KEY MAP

McINTOSH PERRY 115 Walgreen Road, RR3, Carp, ON K0A1L0 Tel: 613-836-2184 Fax: 613-836-3742 www.mcintoshperry.com	PROJECT NO: CCO-21-2955	FIGURE:
	Date	Oct., 19, 2021
	Checked By	AG

C:\Users\uncum\McIntosh Perry\GIS - Documents\Projects\2021\CCO\CCO-21-2955\Comstones - Civil - 1919 Riverside Drive\Key Maps\LandDevelopment\CCO-21-2955_Sited_Location\Plan.aprx

APPENDIX B
BACKGROUND DOCUMENTS

Alison Gosling

From: Moore, Sean <Sean.Moore@ottawa.ca>
Sent: April 29, 2021 12:00 PM
To: Brian Casagrande; Bria Aird; Brad Schlegel
Cc: Moise, Christopher; Hayley, Matthew; Krabicka, Jeannette; Harrold, Eric; Richardson, Mark; Gervais, Josiane; Xu, Lily
Subject: 1919 Riverside Drive / Schlegel Villages site plan
Attachments: Riverside, 1919_UD Comments PRE1.docx; Riverside, 1919_Design Brief.pdf; 210428_1919 Riverside_pre-app consult mtg_PFP comments.pdf

Brian, Bria and Brad,

In regards to our April 22, 2021 preconsultation meeting for a Site Plan Control and Zoning By-law amendment at 1919 Riverside Drive please find our comments and submission requirements below. Myself and our team would be happy to discuss these comments if you have any questions moving forward.

Site Plan Control (complex site plan category):

https://app06.ottawa.ca/online_services/forms/ds/site_plan_control_en.pdf

Zoning By-law Amendment (minor or major, depending upon request):

https://app06.ottawa.ca/online_services/forms/ds/zoning_amendment_en.pdf

List of Reports and Plans:

- The following reports and plans are required (all in digital format from an FTP site) in order to support the proposed Site Plan Control and Minor Zoning By-law amendment applications:
 1. Site Plan
 2. Concept Plan for both phases and interim conditions plan if Phase 2 will be a number of years after Phase 1
 3. Landscape Plan
 4. Tree Conservation Report
 5. Elevation Drawings
 6. Planning Rationale with Design Brief
 7. Sun Shadow Analysis / Wind analysis
 8. Noise and Vibration Study for proximity to Rail and the Transitway.
 9. Transportation Impact Assessment
 10. Archeological Assessment
 11. Phase 1 Environmental Site Assessment / Phase 2 if required. (Ontario Regulation 153/04 Ontario Regulation 153/04)
 12. Site Servicing Plan
 13. Grade Control and Drainage Plan
 14. Erosion and Sediment Control Plan
 15. Stormwater Management Report

16. Site Servicing Study
17. Geotechnical Study
18. A Sewer Flow Management Plan (Standard F1007) will be required, to be reviewed following first submission. The sewer flow management plan details how the Contractor intends to manage the sewer flow through and around the work zone.

Planning Comments:

1. Within the Planning Rationale please illustrate what the FSI of 1.0 restricts the built form to; to illustrate an as of right zoning vs. the proposed. Please provide design and planning rationale for the requested FSI.
2. Please advise if you will be seeking a 'restaurant' use or if the restaurant will be ancillary to the retirement home. This will impact the type of zoning (major vs. minor).
3. We would seek opportunities to connect to the BRT station from an outdoor sidewalk / pathway connection (if possible)
4. Are there opportunities to lower the grade at Smyth Road, such that the Phase 2 building is more at 'street level'
5. We are aware of the 'restrictive covenant' on title, and will provide more information with this as we explore this matter
6. Coupled with the attached Design Comments please refer to the High-Rise Design Guidelines and reference these in your Planning Rationale when you speak to your design considerations
7. Please ensure the Wind and Shadow study are used to inform the design of the buildings
8. Please ensure you understand VIA's requirements upfront ([Paul Charbach@viarail.ca](mailto:Paul.Charbach@viarail.ca)) I will forward you information about VIA's review.

Parks Comments:

- See parks comments attached
- Keep in mind the 30m setback to VIA cannot count towards parkland dedication

Urban Design Comments

- See attached word document
- See attached pdf of the Urban Design Brief terms of reference

Environmental Comments

- Landscaping - OP Section 4.9 - shading for outdoor space to combat the urban heat island
- Bird safe design - https://documents.ottawa.ca/sites/documents/files/birdsafedesign_guidelines_en.pdf

Transportation Comments

- Follow Traffic Impact Assessment Guidelines
 - A TIA is required. Submit Screening Form and Scoping Report at your earliest convenience to Josiane.Gervais@ottawa.ca.
 - Start this process asap. The application will not be deemed complete until the submission of the draft step 1-4, including the functional draft RMA package (if applicable) and/or monitoring report (if applicable).
 - Request base mapping asap if RMA is required. Contact Engineering Services (<https://ottawa.ca/en/city-hall/planning-and-development/engineering-services>)
 - An update to the *TRANS Trip Generation Manual* has been completed (October 2020). This manual is to be utilized for this TIA. A copy of this document can be provided upon request.
 - The presentation noted the Village offers community services and amenities, ensure the TIA trip generation accounts for trips associated with these services.
- Concept as shown results in a closure of one access to the Hospital, the TIA must show how this can be accommodated:
 - Implications to vehicle access and emergency vehicles;
 - Can the single access accommodate all vehicle traffic?

- Are existing turning lanes at Riverside intersection adequate lengths or will they need to be extended? RMA will be required if there are impacts to the intersection.
- Ensure the site plan clearly shows how pedestrians/cyclists from Smyth Road reach the Riverside Campus, the Transit Station and the proposed site.
- Consultation with City Emergency Services is encouraged early in the process to ensure emergency vehicles destined to/from the Riverside Campus and proposed site can be accommodated.
- Specifically for the Smyth Road access:
 - Clear throat requirements for apartments >200 units on an arterial is 40m. This distance must be provided and shown on the Site Plan. Traffic must adequately clear Smyth Road during green time.
 - Stacking must be accommodated on private property for vehicles egressing the site.
 - In addition, the TIA must show if the WB-LT lane at Smyth Road intersection into the site sufficient or will it need to be extended? RMA will be required if there are impacts to the intersection.
- Existing parking that is associated with the existing Riverside Campus will be impacted by this proposal, how are the impacted parking stalls going to be accommodated?
- Show pedestrian pathways on site. Ensure all crosswalks located internally on the site provide a TWSI at the depressed curb, per requirements of the Integrated Accessibility Standards Regulation under the AODA.
- On site plan:
 - Show all details of the roads abutting the site up to and including the opposite curb; include such items as pavement markings, accesses and/or sidewalks.
 - Turning movement diagrams required for all accesses showing the largest vehicle to access/egress the site.
 - Turning movement diagrams required for internal movements (loading areas, garbage).
 - Show all curb radii measurements; ensure that all curb radii are reduced as much as possible
 - Show lane/aisle widths.
 - Sidewalk is not to be continuous across access as per City Specification 7.1.
 - Grey out any area that will not be impacted by this application.
 - Show slope of garage ramp on site plan. Note that underground ramps should be limited to a 12% grade and must contain a subsurface melting device when exceeding 6%. Ramp grades greater than 15% can be psychological barriers to some drivers.
- As the proposed site is institutional and for general public use, AODA legislation applies.
- Consider using the City's Accessibility Design Standards.
- Noise Impact Studies required for the following:
 - Road
 - Rail
 - Stationary, due to the proximity to neighboring exposed mechanical equipment, and/or if there will be any exposed mechanical equipment due to the proximity to neighboring noise sensitive land uses.

Engineering Comments

Please note the following information regarding the engineering design submissions for the above noted site:

1. The Servicing Study Guidelines for Development Applications are available at the following address:

<https://ottawa.ca/en/city-hall/planning-and-development/how-develop-property/development-application-review-process-2/guide-preparing-studies-and-plans>
2. Servicing and site works shall be in accordance with the following documents:
 - Ottawa Sewer Design Guidelines (October 2012) and all the Technical Bulletins including, Technical Bulletin PIEDTB-2016-01 and ISTB-2018-01
 - Ottawa Design Guidelines – Water Distribution (2010) and Technical Bulletins ISD-2010-2, ISDTB-2014-02 and ISTB-2018-02

- Geotechnical Investigation and Reporting Guidelines for Development Applications in the City of Ottawa (2007)
 - City of Ottawa Slope Stability Guidelines for Development Applications (revised 2012)
 - City of Ottawa Environmental Noise Control Guidelines (January, 2016)
 - City of Ottawa Park and Pathway Development Manual (2012)
 - City of Ottawa Accessibility Design Standards (2012)
 - Ottawa Standard Tender Documents (latest version)
 - Ontario Provincial Standards for Roads & Public Works (2013)
3. Record drawings and utility plans are also available for purchase from the City (Contact the City's Information Centre by email at InformationCentre@ottawa.ca or by phone at (613) 580-2424 x 44455
4. The Stormwater Management Criteria, for the subject site, is to be based on the following:
- Stormwater flows controlled to the 5 year event using Allowable Runoff Coefficient (C) = 0.5
 - Due to location of the storm outlet to the Rideau River, surcharging is a possibility and should be considered.
 - The 2-yr storm or 5-yr storm event using the IDF information derived from the Meteorological Services of Canada rainfall data, taken from the MacDonald Cartier Airport, collected 1966 to 1997.
 - A calculated time of concentration (Cannot be less than 10 minutes).
 - Flows to the storm sewer in excess of the 5-year storm release rate, up to and including the 100-year storm event, must be detained on site.
 - Please contact RVCA for specific water quality requirement (discharge to Rideau River).
 - Note that there are known drainage issues near the railroad abutting the property, and that the Rideau River is prone to surcharge.
 - Note: There may be area specific SWM Criteria that may apply. Check for any related SWM &/or Sub-watershed studies that may have been completed.

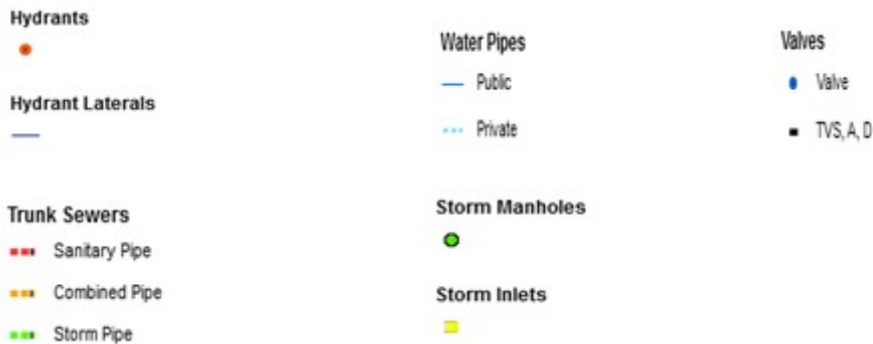
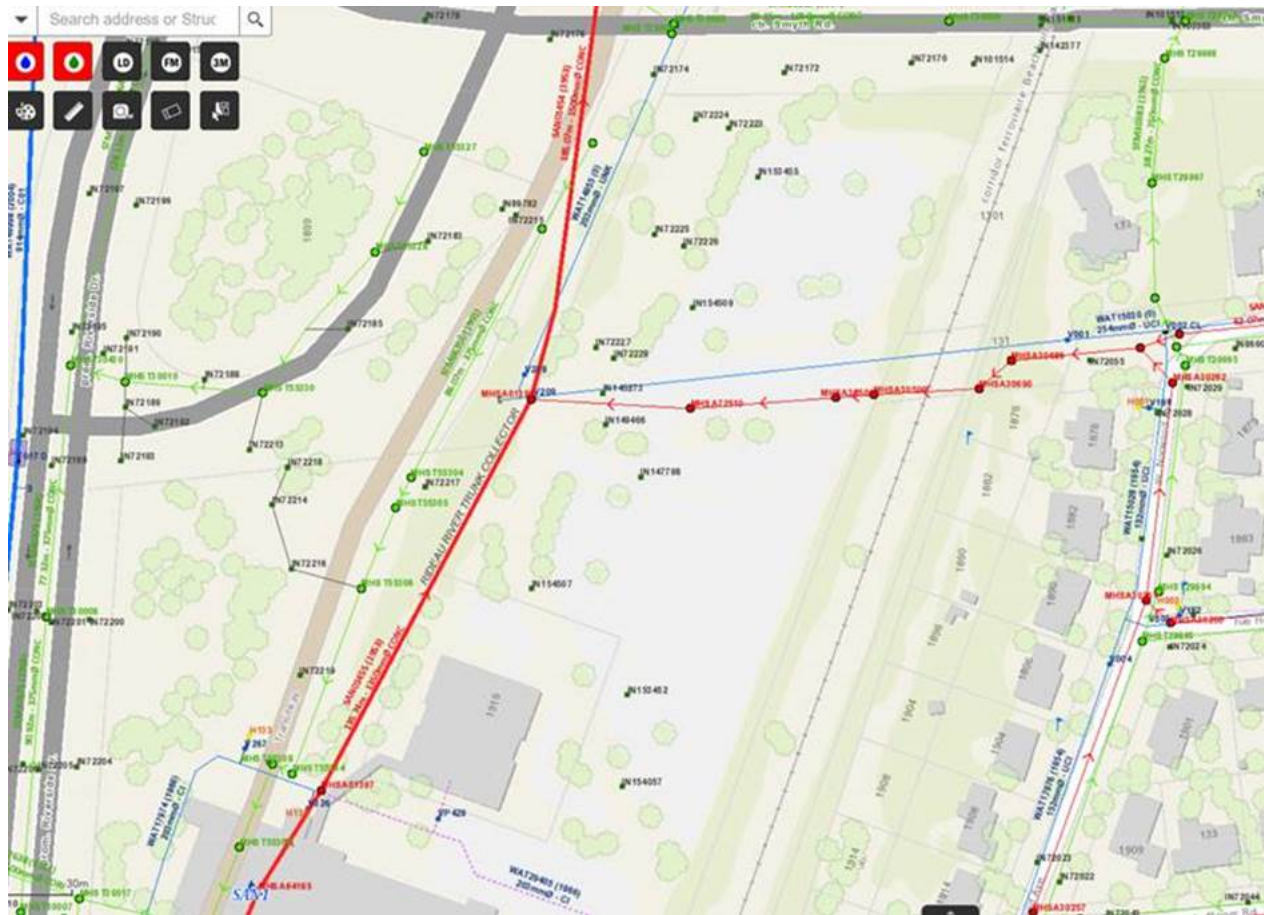

5. Services (Storm, Sanitary & Water Supply):

- i. A plan view of the approximate services is shown above. Services should ideally be grouped in a common trench to minimize the number of road cuts. The sizing of available future services is:
 - a. Connections (Sewers on Riverside Drive - Preferred):
 - i. 450 mm dia. STM (Conc.). Note that there is existing stormwater management infrastructure beneath the northern portion of the parking area.
 - ii. 203 mm private dia. Watermain (UNK). This private watermain currently services the Riverside campus, and has a redundant connection to the watermains located along Riverside Drive and Rodney Crescent.
 - iii. 254 mm dia. Watermain (UCI). This watermain must be relocated, as it underlies the Phase II building footprint. The watermain should be relocated to the north. The un-used

portion of pipe will need to be abandoned. A Form 1 from the MECP will be required prior to issuance of the Commence Work Notification. Due to the relocation of existing services in this area, the City's Asset Management group will be circulated on technical submissions for comment. The City's Asset Management group indicated this this watermain must be relocated, and not terminated.

- iv. 675 mm dia. SAN (Conc.). A portion of this sewer must be relocated, as it underlies the Phase II building footprint. The sewer should be relocated to the north, wrapping around the proposed building, and returning towards the south so that the existing connection to the 1350 mm trunk sewer can be re-used. The City does not support a new connection to the 1350 mm trunk sewer.
- ii. *Provide existing servicing information and the recommended location for the proposed connections. Services should ideally be grouped in a common trench to minimize the number of road cuts.*
- iii. *Connections to trunk sewers and easement sewers are typically not permitted. Connection to the trunk storm on Riverside is permitted for this site plan*
- iv. *Provide information on the monitoring manhole requirements – should be located in an accessible location on private property near the property line (ie. Not in a parking area).*
- v. *Review provision of a high-level sewer.*
- vi. *Provide information on the type of connection permitted*

Sewer connections to be made above the springline of the sewermain as per:

- a. Std Dwg S11.1 for flexible main sewers – *connections made using approved tee or wye fittings.*
 - b. Std Dwg S11 (For rigid main sewers) – *lateral must be less than 50% the diameter of the sewermain,*
 - c. Std Dwg S11.2 (for rigid main sewers using bell end insert method) – *for larger diameter laterals where manufactured inserts are not available; lateral must be less than 50% the diameter of the sewermain,*
 - d. *Connections to manholes permitted when the connection is to rigid main sewers where the lateral exceeds 50% the diameter of the sewermain. – Connect obvert to obvert with the outlet pipe unless pipes are a similar size.*
 - e. *No submerged outlet connections.*
6. Water Boundary condition requests must include the location of the service and the expected loads required by the proposed development. Please provide the following information:
- i. Location of service
 - ii. Type of development and the amount of fire flow required (as per FUS, 1999).
 - iii. Average daily demand: ___ l/s.
 - iv. Maximum daily demand: ___ l/s.
 - v. Maximum hourly daily demand: ___ l/s.
 - vi. Hydrant location and spacing to meet City's Water Design guidelines.

- vii. Water supply redundancy will be required for more than 50 m³/day water demand. Note that this is a supply sensitive user, and as such the facility will require two separate water services. The existing private watermain servicing the Riverside campus has an existing redundant connection to the watermain on Rodney Crescent.
7. Phase 1 Environmental Site Assessment (ESA) and Phase 2 ESAs must conform to clause 4.8.4 of the Official Plan that requires that development applications conform to Ontario Regulation 153/04. The ESA may provide recommendations where site contamination may be present. The recommendations from the ESA need to be coordinated with the servicing report to ensure compliance with the Sewer Use By-Law.
 8. MECP ECA Requirements – All development applications should be considered for an Environmental Compliance Approval (ECA) by the Ministry of the Environment, Conservation, and Parks (MECP);
 - a. The consultants determine if an approval for sewage works under Section 53 of OWRA is required and determines what type of application. The City’s project manager may help confirm and coordinate with the MECP as required.
 - b. The project will be either transfer of review (standard), transfer of review (additional), direct submission, or exempt as per O. Reg. 525/98.
 - c. Pre-consultation is not required if applying for standard or additional works (Schedule A of the Agreement) under Transfer Review.
 - d. Pre-consultation with local District office of MECP is recommended for direct submission.
 - e. Consultant completes an MECP request form for a pre-consultation. Sends request to moeccottawasewage@ontario.ca
 - f. ECA applications are required to be submitted online through the MECP portal. A business account required to submit ECA application. For more information visit <https://www.ontario.ca/page/environmental-compliance-approval>
 - g. A Transfer of Review (TOR) ECA will likely be required for the sanitary sewer relocation.
 - h. Water supply redundancy will be required for more than 50 m³/day water demand. Provide watermain looped connection or with isolation valve to meet this requirement.

NOTE: Site Plan Approval, or Draft Approval, is required before an application is sent to the MECP.

9. Please contact RVCA for specific water quality requirements (discharge to Rideau River).
10. General Engineering Submission requirements:
 - a. As per section 53 of the Professional Engineers Act, O. Reg 941/40, R.S.O. 1990, all documents prepared by engineers must be signed and dated on the seal.
 - b. All required plans are to be submitted on standard A1 size sheets (594mm x 841mm) sheets, utilizing a reasonable and appropriate metric scale as per City of Ottawa Servicing and Grading Plan Requirements: title blocks are to be placed on the right of the sheets and not along the bottom. Engineering plans may be combined, but the Site Plans must be provided separately. Plans shall include the survey monument used to confirm datum. Information shall be provided to enable a non-surveyor to locate the survey monument presented by the consultant.
 - c. All required plans & reports are to be provided in *.pdf format (at application submission and for any, and all, re-submissions).
 - d. Engineering Reports and Drawings can be requested from the ISD Information Centre by emailing informationcentre@ottawa.ca.

Should you have any questions or require additional information, please contact me directly at (613) 580-2424, ext. 21447 or by email at eric.harrold@ottawa.ca.

TCR requirements:

1. a Tree Conservation Report (TCR) must be supplied for review along with the suite of other plans/reports required by the City
 - a. an approved TCR is a requirement of Site Plan approval.
2. As of January 1 2021, any removal of privately-owned trees 10cm or larger in diameter, or publicly (City) owned trees of any diameter requires a tree permit issued under the Tree Protection Bylaw (Bylaw 2020 – 340); the permit will be based on an approved TCR and made available at or near plan approval.
3. The Planning Forester from Planning and Growth Management as well as foresters from Forestry Services will review the submitted TCR
 - a. If tree removal is required, both municipal and privately-owned trees will be addressed in a single permit issued through the Planning Forester
 - b. Compensation may be required for city owned trees – if so, it will need to be paid prior to the release of the tree permit
4. the TCR must list all trees on site by species, diameter and health condition
5. please identify trees by ownership – private onsite, private on adjoining site, city owned, co-owned (trees on a property line)
6. the TCR must list all trees on adjacent sites if they have a critical root zone that extends onto the development site
7. If trees are to be removed, the TCR must clearly show where they are, and document the reason they cannot be retained
8. All retained trees must be shown and all retained trees within the area impacted by the development process must be protected as per City guidelines available at [Tree Protection Specification](#) or by searching Ottawa.ca
 - a. the location of tree protection fencing must be shown on a plan
 - b. show the critical root zone of the retained trees
 - c. if excavation will occur within the critical root zone, please show the limits of excavation
9. the City encourages the retention of healthy trees; if possible, please seek opportunities for retention of trees that will contribute to the design/function of the site.
10. For more information on the process or help with tree retention options, contact Mark Richardson mark.richardson@ottawa.ca or on [City of Ottawa](#)

Landscape Plan and tree planting requirements:

For additional information on the following please contact tracy.smith@Ottawa.ca

Minimum Setbacks

- Maintain 1.5m from sidewalk or MUP/cycle track.
- Maintain 2.5m from curb
- Coniferous species require a minimum 4.5m setback from curb, sidewalk or MUP/cycle track/pathway.
- Maintain 7.5m between large growing trees, and 4m between small growing trees. Park or open space planting should consider 10m spacing.
- Adhere to Ottawa Hydro's planting guidelines (species and setbacks) when planting around overhead primary conductors.

Tree specifications

- Minimum stock size: 50mm tree caliper for deciduous, 200cm height for coniferous.
- Maximize the use of large deciduous species wherever possible to maximize future canopy coverage
- Tree planting on city property shall be in accordance with the City of Ottawa’s Tree Planting Specification; and include watering and warranty as described in the specification (can be provided by Forestry Services).
- Plant native trees whenever possible
- No root barriers, dead-man anchor systems, or planters are permitted.
- No tree stakes unless necessary (and only 1 on the prevailing winds side of the tree)

Hard surface planting

- Curb style planter is highly recommended
- No grates are to be used and if guards are required, City of Ottawa standard (which can be provided) shall be used.
- Trees are to be planted at grade

Soil Volume

- Please ensure adequate soil volumes are met:

Tree Type/Size	Single Tree Soil Volume (m3)	Multiple Tree Soil Volume (m3/tree)
Ornamental	15	9
Columnar	15	9
Small	20	12
Medium	25	15
Large	30	18
Conifer	25	15

Please note that these soil volumes are not applicable in cases with Sensitive Marine Clay.

Sensitive Marine Clay

- Please follow the City’s 2017 Tree Planting in Sensitive Marine Clay guidelines

APPLICATION SUBMISSION:

- Planning Operations has created a detailed process for the receipt and handling of applications sent to the Planning Circulations inbox. PlanningCirculations@ottawa.ca All applications are to be sent to this inbox so that the MAP files can be created, and materials uploaded to both SharePoint and MAP.

1. THINGS TO NOTE

- Payment Initiation:** Once the digital files have been sent to PlanningCirculations@ottawa.ca a submissions email will be forwarded to the applicant in order to initiate payment for the application.
- Payments:** Application payments will now be handled by the Client Service Centre. Details on how to make such payments are included within the email to the applicants. Please note, EFT and Wire Transfers are no longer being accepted as payment methods.

Regards,

Sean Moore, RPP/MCIP
 Senior Planner
 Development Review South Unit
 Planning, Infrastructure and Economic Development Dept.
 City of Ottawa

Cell: 613-805-9804

- Please note I am working from home during this crisis until further notice

'

This e-mail originates from the City of Ottawa e-mail system. Any distribution, use or copying of this e-mail or the information it contains by other than the intended recipient(s) is unauthorized. Thank you.

Le présent courriel a été expédié par le système de courriels de la Ville d'Ottawa. Toute distribution, utilisation ou reproduction du courriel ou des renseignements qui s'y trouvent par une personne autre que son destinataire prévu est interdite. Je vous remercie de votre collaboration.

'

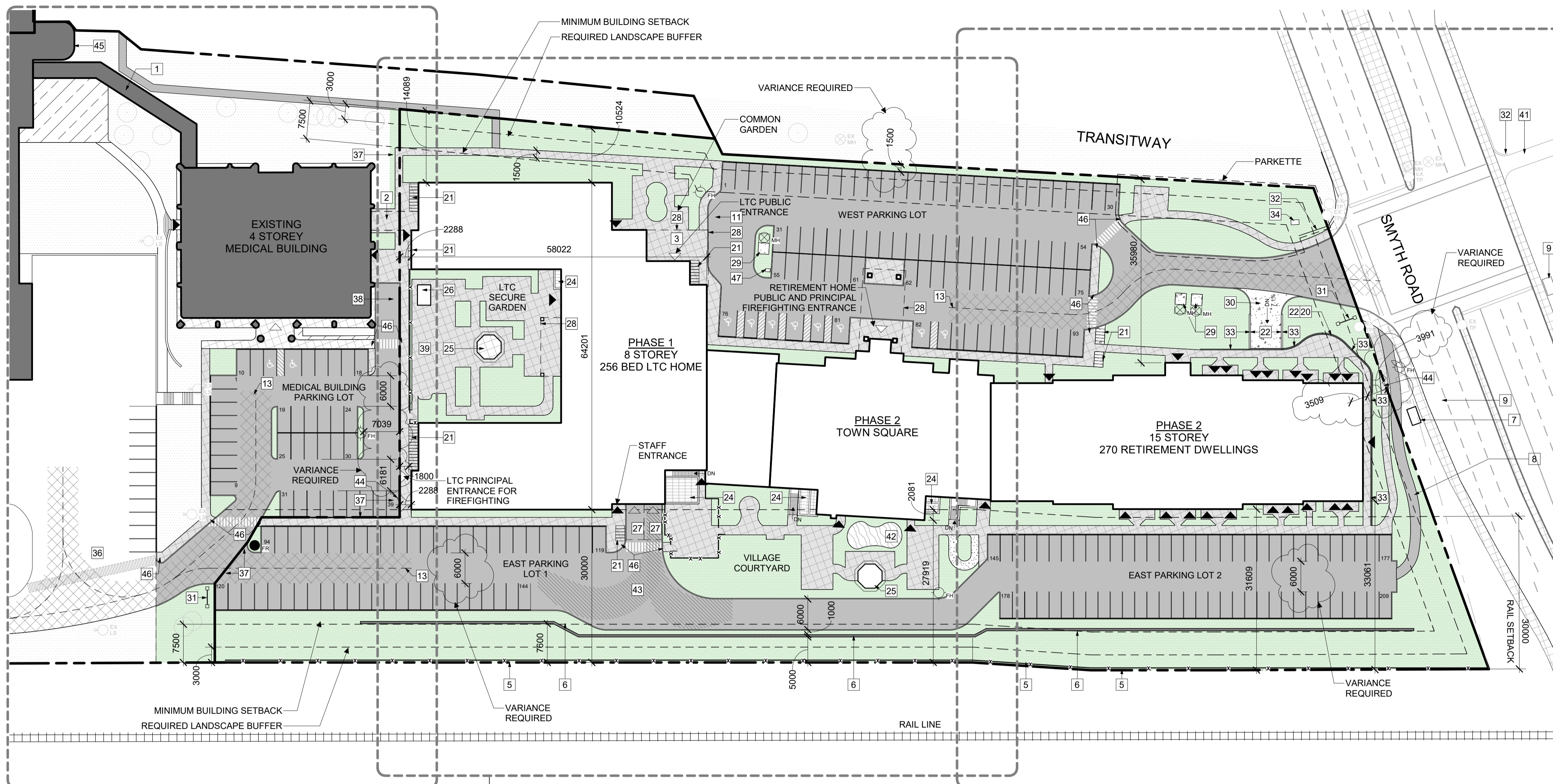

SITE PLAN GENERAL NOTES:

1. ALL GENERAL SITE INFORMATION AND CONDITIONS COMPILED FROM EXISTING PLANS AND SURVEYS
2. DO NOT SCALE THIS DRAWING
3. REPORT ANY DISCREPANCIES PRIOR TO COMMENCING WORK. NO RESPONSIBILITY IS BORN BY THE CONSULTANT FOR UNKNOWN SUBSURFACE CONDITIONS
4. CONTRACTOR TO CHECK AND VERIFY ALL DIMENSIONS ON SITE AND REPORT ANY ERRORS AND/OR OMISSIONS TO THE CONSULTANT
5. REINSTATE ALL AREAS AND ITEMS DAMAGED AS A RESULT OF CONSTRUCTION ACTIVITIES TO THE SATISFACTION OF THE CONSULTANT
6. CONTRACTOR TO LAYOUT PLANTING BEDS, PATHWAYS ETC. TO APPROVAL OF CONSULTANT PRIOR TO ANY JOB EXCAVATION
7. THE ACCURACY OF THE POSITION OF UTILITIES IS NOT GUARANTEED - CONTRACTOR TO VERIFY PRIOR TO EXCAVATION
8. INDIVIDUAL UTILITY COMPANY MUST BE CONTACTED FOR CONFIRMATION OF UTILITY EXISTENCE AND LOCATION PRIOR TO DIGGING
9. ALL DISTURBED AREAS TO BE RESTORED TO ORIGINAL CONDITION OR BETTER UNLESS OTHERWISE NOTED

SITE PLAN LEGEND:

- EXISTING BUILDING
- EXISTING GRASS/SOFT LANDSCAPE - REFER TO LANDSCAPE DRAWINGS
- EXISTING SIDEWALK
- NEW ASPHALT PAVING
- NEW GRASS / SOFT LANDSCAPE - REFER TO LANDSCAPE DRAWINGS
- CONCRETE SIDEWALK
- CONCRETE PAD
- STONE DUST/SAND
- PEDESTRIAN CROSSWALK
- EXISTING PAVERS
- FIRE ROUTE
- FIRE ROUTE
- OTHER ENTRANCE / EXIT
- SERVICE DOORS
- BUILDING MAIN ENTRANCE
- PROPERTY LINE
- FENCE - REFER TO LANDSCAPE PLANS
- RELOCATED UNDERGROUND SERVICES - REFER TO CIVIL FOR DETAILS
- LIMIT OF WORK
- EXISTING LIGHT STANDARD
- EXISTING MANHOLE
- EXISTING UTILITY POLE
- EXISTING TRAFFIC LIGHT POLE
- FIRE ROUTE SIGN
- SIAMESE CONNECTION
- FIRE HYDRANT
- EXISTING UTILITY COVER AT SURFACE
- ACCESS AISLE
- FIRE TRUCK TURNAROUND FACILITY
- PROPOSED PROPERTY LINE
- EXISTING LOADING / GARBAGE AREA
- MOBILITY GARDEN - REFER TO LANDSCAPE PLANS
- EXISTING BUS SHELTER
- EXISTING MULTI-USE PATHWAY
- POND
- DELIVERY TRUCK TURNAROUND FACILITY
- SIAMESE CONNECTION
- EXISTING ACCESS TO TRANSIT STATION
- TACTILE WALKING SURFACE INDICATOR (TWSI)
- COMMUNICATIONS PULLBOX

1 SITE PLAN - MASTER PLAN
A1.02 | 1 : 500 (WHEN PLOTTED ON A1 SIZED SHEET)

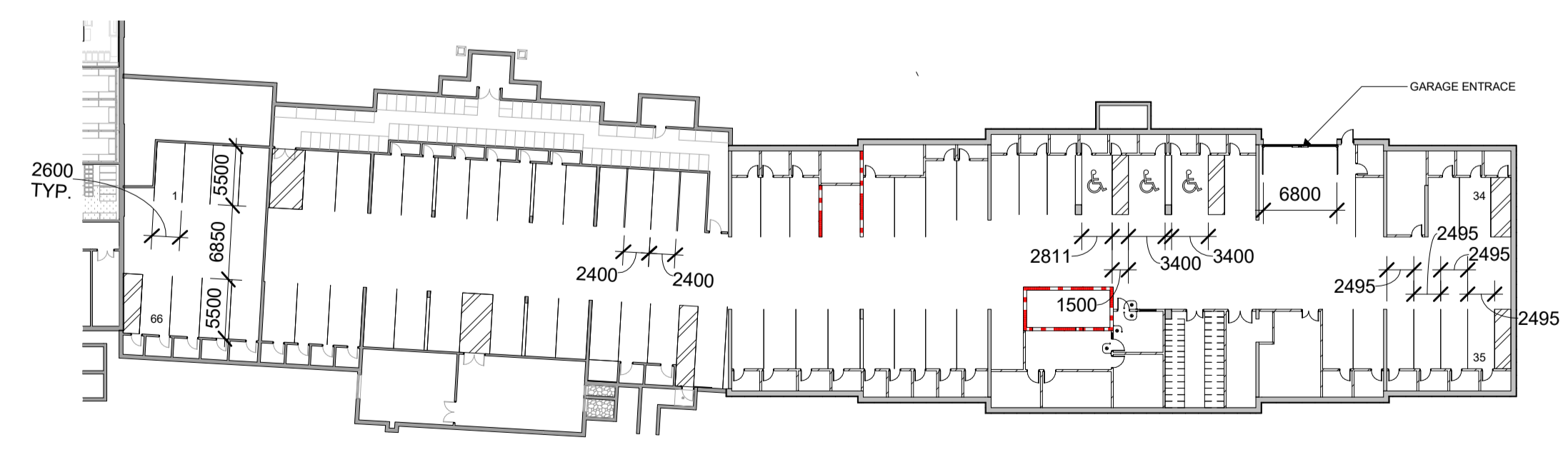

2 PARKING LAYOUT
A1.02 | 1 : 500 (WHEN PLOTTED ON A1 SIZED SHEET)

SITE PLAN LEGEND:

- 1 EXISTING RAISED PEDESTRIAN LINK
- 2 POTENTIAL PEDESTRIAN LINK
- 3 LTC PORCH
- 4 NEW FENCE AND GATE
- 5 NEW 1829mm HIGH CHAIN LINK FENCE
- 6 NEW 450mm THICK, 2135mm HIGH CONCRETE CRASH WALL
- 7 EXISTING BUS SHELTER (RELOCATED)
- 8 NEW BIKE PATH
- 9 END OF FUTURE BIKE LANE
- 11 LAY-BY
- 13 END OF FIRE ROUTE
- 20 LOOKOUT
- 21 BICYCLE PARKING
- 22 RETAINING WALL
- 24 AREAWAY
- 25 GAZEBO
- 26 SHED
- 27 LOADING ZONE
- 28 OVERHANG ABOVE
- 29 HYDRO BOX
- 30 HEATED RAMP
- 31 SIGNAGE
- 32 EXISTING ROAD BARRIER
- 33 1100 mm HIGH GUARD
- 34 EXISTING UTILITY COVER AT SURFACE
- 35 ACCESS AISLE
- 36 FIRE TRUCK TURNAROUND FACILITY
- 37 PROPOSED PROPERTY LINE
- 38 EXISTING LOADING / GARBAGE AREA
- 39 MOBILITY GARDEN - REFER TO LANDSCAPE PLANS
- 40 EXISTING BUS SHELTER
- 41 EXISTING MULTI-USE PATHWAY
- 42 POND
- 43 DELIVERY TRUCK TURNAROUND FACILITY
- 44 SIAMESE CONNECTION
- 45 EXISTING ACCESS TO TRANSIT STATION
- 46 TACTILE WALKING SURFACE INDICATOR (TWSI)
- 47 COMMUNICATIONS PULLBOX

100-190 O'Connor St., Ottawa ON Canada K 5C7
P 613 564 8118
www.csv.ca

CSV ARCHITECTS
sustainable design - conception écologique

ISSUED FOR REVIEW
ISSUED FOR SITE PLAN CONTROL, RE-SUBMISSION

© 2021 CSV Architects Incorporated. All Rights Reserved.

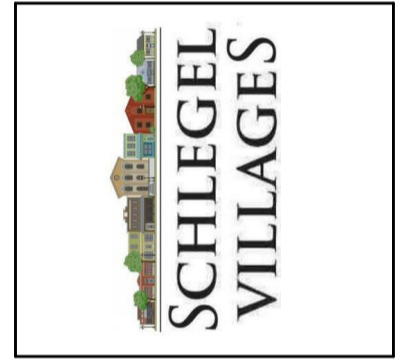

SCHLEGEL VILLAGES OTTAWA
SMYTH ROAD & RIVERSIDE DRIVE, OTTAWA, ONTARIO

MASTER PLAN

Project No.: 202090
Drawn By: MM
Plot Date: 2022-04-06
2021-07-15PM

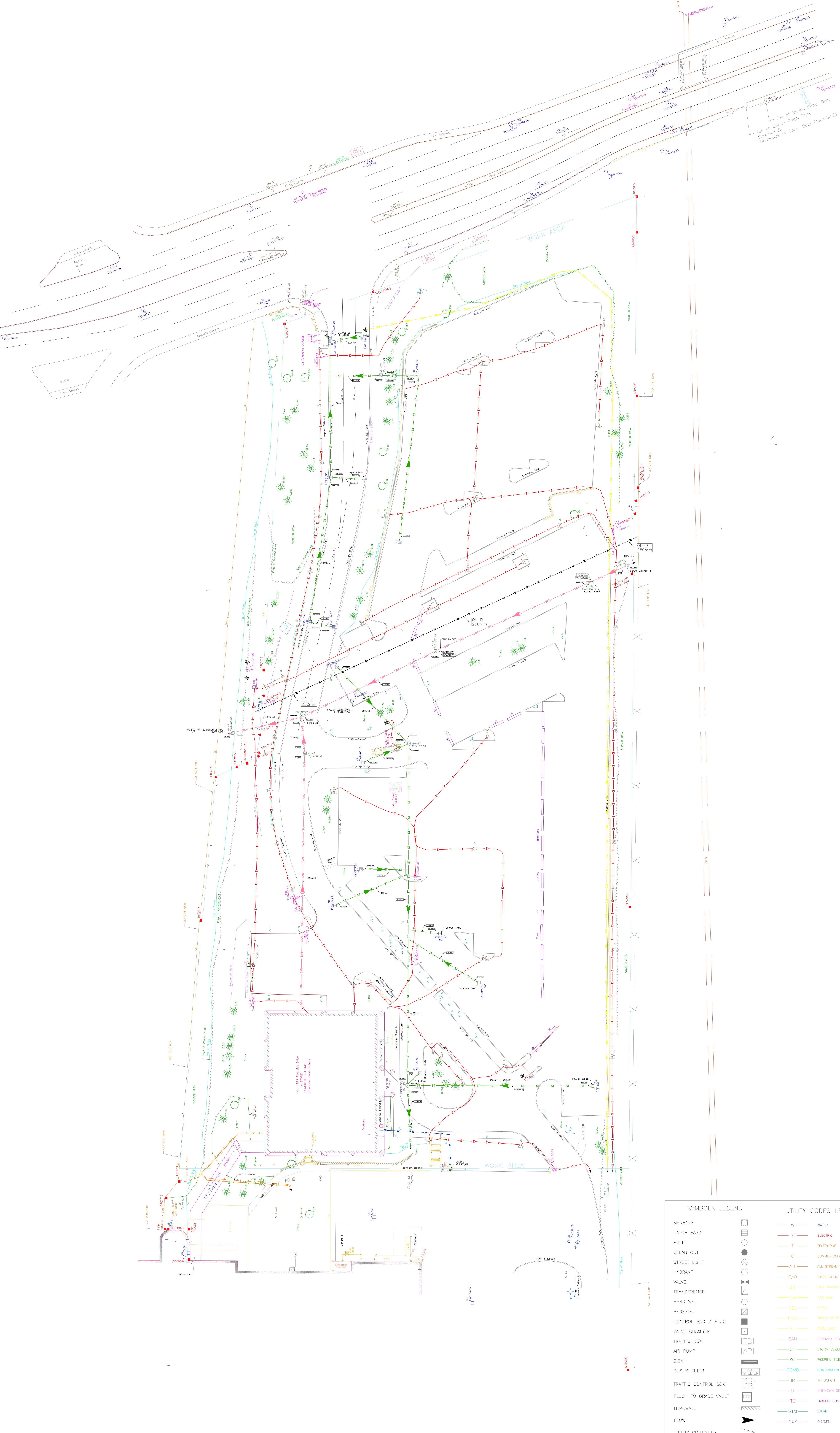

Top of Buried Conc. Duct Elev.=61.38
 Underside of Conc. Duct Elev.=60.82



Utility Mapping Quality Levels
 as per ASCE C-1 38-02

QL-A - Locating exact vertical and horizontal position of underground utilities using appropriate safe excavation techniques and recording these data.

QL-B - Designating the horizontal position of underground utilities by the application of appropriate surface geophysical methods.
 - Limited in scope to verification of provided level D information.
 - Utilities may escape detection. (See Notes)

QL-C - Survey of surface features.

QL-D - Records and plans research including record collection and review.

Notes:

- This information is provided for design purposes only.
- This information is not a substitute for sanctioned locates as provided by the utility owner.
- Prior to any excavation, all utility owners must be contacted to obtain sanctioned locates, as stipulated by the Occupational Health & Safety Act.
- Inferred utility depths indicated on this drawing are only estimates and should be verified by direct physical exposure.
- Underground infrastructure shown on this drawing was obtained on a best-effort, best-practices basis, within the technical limitations of the instrumentation.
- The spatial accuracy of the plotted information is dependent on the accuracy of the base map information as provided by others.
- This information is provided on a best effort basis within the limitations of the technology. Consequently some utilities may escape detection (i.e. non-conductive, inaccessible, incomplete level D information provided by the Client and/or physical expression not reasonably identifiable at the time of the survey, etc.)
- The information herein documents the position of suspected or known utilities existing at this site as of the drawing date.
- Quality Level 'D' information was obtained by MARK IT Locates Inc. during the course of this investigation.

SYMBOLS LEGEND	
MANHOLE	[Symbol]
CATCH BASIN	[Symbol]
POLE	[Symbol]
CLEAN OUT	[Symbol]
STREET LIGHT	[Symbol]
HYDRANT	[Symbol]
VALVE	[Symbol]
TRANSFORMER	[Symbol]
HAND WELL	[Symbol]
PEDESTAL	[Symbol]
CONTROL BOX / PLUG	[Symbol]
VALVE CHAMBER	[Symbol]
TRAFFIC BOX	[Symbol]
AIR PUMP	[Symbol]
SIGN	[Symbol]
BUS SHELTER	[Symbol]
TRAFFIC CONTROL BOX	[Symbol]
FLUSH TO GRADE VAULT	[Symbol]
HEADWALL	[Symbol]
FLOW	[Symbol]
UTILITY CONTINUES	[Symbol]
TEST PIT	[Symbol]

UTILITY CODES LEGEND	
W	WATER
E	ELECTRIC
T	TELEPHONE
C	COMMUNICATION CABLES/DUCT
ALL	ALL STREAM
F/O	FIBER OPTIC
CS	GAS SERVICE
GM	GAS MAIN
DZL	DIESEL
TNPL	TRANS NORTHERN PIPELINE
FL	FUEL LINE
SAN	SANITARY SEWER
ST	STORM SEWER
WT	WEeping TILE
COMB	COMBINATION SEWER
IR	IRRIGATION
U	UNKNOWN SERVICE
TC	TRAFFIC CONTROL
STM	STEAM
OXY	OXYGEN

TOPOGRAPHICAL PLAN OF PART OF NORTHERLY
EASTERLY AND WESTERLY BOUNDARY OF
PIN 04201 - 0191 AND PIN 04201 - 0147 BEING

PART OF LOTS 15 and 16
JUNCTION GORE
and
PART OF ROAD ALLOWANCE BETWEEN
LOTS 15 and 16
JUNCTION GORE
(closed by By-Law 174-88, Inst. N451929)
Geographic Township of Gloucester
CITY OF OTTAWA

Surveyed by Annis, O'Sullivan, Vollebek Ltd.

Scale 1:300

Metric
DISTANCES SHOWN ON THIS PLAN ARE IN METRES AND
CAN BE CONVERTED TO FEET BY DIVIDING BY 0.3048

Surveyor's Certificate

I, CERTIFY THAT:
1. This survey and plan are correct and in accordance with the Survey
Act and the Surveyors Act and the regulations made under them.
2. The survey was completed on the 18th day of December, 2020.

Date: _____
E. H. Henoyer
Ontario Land Surveyor

Notes & Legend

- | | |
|---|---|
| — | Denotes |
| — | Survey Monument Planted |
| — | Survey Monument Found |
| — | Standard Iron Bar |
| — | Short Standard Iron Bar |
| — | Iron Bar |
| — | Cut Cross |
| — | Concrete Pin |
| — | Rock Pin |
| — | Witness |
| — | Measured |
| — | Annis, O'Sullivan, Vollebek Ltd. |
| — | Plan 48-19213 |
| — | Deciduous Tree |
| — | Coniferous Tree |
| — | Fire Hydrant |
| — | Water Valve |
| — | Water Stand Post |
| — | Maintenance Hole (Storm Sewer) |
| — | Maintenance Hole (Sanitary) |
| — | Maintenance Hole (Bell Telephone) |
| — | Maintenance Hole (Traffic) |
| — | Maintenance Hole (Hydro) |
| — | Maintenance Hole (Gas) |
| — | Maintenance Hole (Undersized) |
| — | Valve Chamber (Waterman) |
| — | Catch Basin |
| — | Catch Basin Inlet |
| — | Handhole |
| — | Belt Terminal Box |
| — | Cable Terminal Box |
| — | Traffic Terminal Box |
| — | Undersized Terminal Box |
| — | Traffic Signal Post |
| — | Wood Pole |
| — | Metal Pole |
| — | Concrete Pole |
| — | Traffic Light |
| — | Utility Pole |
| — | Anchor |
| — | Light Standard |
| — | Location of Elevations |
| — | Top of Concrete Curb Elevation |
| — | Location of Elevations at Top of Retaining Wall |
| — | Carline |
| — | Top of Grade |
| — | Stone Retaining Wall |
| — | Concrete Retaining Wall |
| — | Bolted |
| — | Sign |
| — | Parking Meter |
| — | Diameter |
| — | Chain Link Fence |
| — | Access Barrier |
| — | Compugated Plastic Pipe |
| — | Top of Pipe |

ELEVATION NOTES

1. Elevations shown are geodetic and are referred to the CGVD2011 geodetic datum.
2. It is the responsibility of the user of this information to verify that the job benchmark
has not been altered or disturbed and that its relative elevation and description
agrees with the information shown on this drawing.

UTILITY NOTES

1. This drawing cannot be accepted as acknowledging all of the utilities and it will
be the responsibility of the user to contact the respective utility authorities for
confirmation.
2. Only visible surface utilities were located.
3. A field location of underground plans by the pertinent utility authority is
mandatory before any work involving breaking ground, probing, excavating, etc.

Bearings are gtd. derived from the easterly limit of Part 31 Plan
48-19213 shown to be N19°57'30"E Bearing, MTM Zone 8 (78°30'
West Longitude) NAD-83 (original).

APPENDIX C
WATERMAIN CALCULATIONS

McINTOSH PERRY

CCO-21-2955 - 1919 Riverside Dr - Phase 1 - Water Demands

Project:	1919 Riverside Dr - Phase 1
Project No.:	CCO-21-2955
Designed By:	AJG
Checked By:	RDF
Date:	April 1, 2022

LTC Home	256 beds
LTC Home Staff	85 persons

AVERAGE DAILY DEMAND

DEMAND TYPE	AMOUNT	UNITS
Residential	280	L/c/d
Industrial - Light	35,000	L/gross ha/d
Industrial - Heavy	55,000	L/gross ha/d
Nursing Homes & Rest Homes	450	L/bed /d
Medical Office - Doctors, Nurses & Medical Staff	275	L/person/day
Tourist Commercial	28,000	L/gross ha/d
Other Commercial	28,000	L/gross ha/d
AVERAGE DAILY DEMAND	1.60	L/s
	96.23	L/min

MAXIMUM DAILY DEMAND

DEMAND TYPE	AMOUNT	UNITS
Residential	2.2	x avg. day L/c/d
Industrial	1.5	x avg. day L/gross ha/d
Commercial	1.5	x avg. day L/gross ha/d
Institutional	1.5	x avg. day L/gross ha/d
MAXIMUM DAILY DEMAND	2.41	L/s
	144.35	L/min

MAXIMUM HOUR DEMAND

DEMAND TYPE	AMOUNT	UNITS
Residential	5.5	x avg. day L/c/d
Industrial	1.8	x max. day L/gross ha/d
Commercial	1.8	x max. day L/gross ha/d
Institutional	1.8	x max. day L/gross ha/d
MAXIMUM HOUR DEMAND	4.33	L/s
	259.83	L/min

WATER DEMAND DESIGN FLOWS PER UNIT COUNT
CITY OF OTTAWA - WATER DISTRIBUTION GUIDELINES, JULY 2010

AVERAGE DAILY DEMAND	1.60	L/s
MAXIMUM DAILY DEMAND	2.41	L/s
MAXIMUM HOUR DEMAND	4.33	L/s

McINTOSH PERRY

CCO-21-2955 - 1919 Riverside Dr - Ultimate - Water Demands

Project:	1919 Riverside Dr - Ultimate
Project No.:	CCO-21-2955
Designed By:	AJG
Checked By:	RDF
Date:	April 1, 2022

LTC Home	256 beds
LTC Home Staff	85 persons
Retirement Home	270 beds
Retirement Home Staff	60 persons

AVERAGE DAILY DEMAND

DEMAND TYPE	AMOUNT	UNITS
Residential	280	L/c/d
Industrial - Light	35,000	L/gross ha/d
Industrial - Heavy	55,000	L/gross ha/d
Nursing Homes & Rest Homes	450	L/bed /d
Medical Office - Doctors, Nurses & Medical Staff	275	L/person/day
Tourist Commercial	28,000	L/gross ha/d
Other Commercial	28,000	L/gross ha/d
AVERAGE DAILY DEMAND	3.20	L/s
	192.07	L/min

MAXIMUM DAILY DEMAND

DEMAND TYPE	AMOUNT	UNITS
Residential	2.2	x avg. day L/c/d
Industrial	1.5	x avg. day L/gross ha/d
Commercial	1.5	x avg. day L/gross ha/d
Institutional	1.5	x avg. day L/gross ha/d
MAXIMUM DAILY DEMAND	4.80	L/s
	288.10	L/min

MAXIMUM HOUR DEMAND

DEMAND TYPE	AMOUNT	UNITS
Residential	5.5	x avg. day L/c/d
Industrial	1.8	x max. day L/gross ha/d
Commercial	1.8	x max. day L/gross ha/d
Institutional	1.8	x max. day L/gross ha/d
MAXIMUM HOUR DEMAND	8.64	L/s
	1,584.54	L/min

WATER DEMAND DESIGN FLOWS PER UNIT COUNT
CITY OF OTTAWA - WATER DISTRIBUTION GUIDELINES, JULY 2010

AVERAGE DAILY DEMAND	3.20	L/s
MAXIMUM DAILY DEMAND	4.80	L/s
MAXIMUM HOUR DEMAND	8.64	L/s

McINTOSH PERRY

CCO-21-2955 - 1919 Riverside Dr - Phase 1 - OBC Fire Calculations

Project:	1919 Riverside Dr - Phase 1
Project No.:	CCO-21-2955
Designed By:	AJG
Checked By:	RDF
Date:	April 1, 2022

Ontario 2006 Building Code Compendium (Div. B - Part 3)

Water Supply for Fire-Fighting - Retirement & LTC Home

Building is classified as Group : **B** (from table 3.2.2.55)

Building is of noncombustible construction with fire separations and fire-resistance ratings provided in accordance with subsections 3.2.2., including loadbearing walls, columns and arches

From Div. B A-3.2.5.7. of the Ontario Building Code - 3. Building On-Site Water Supply:

(a) $Q = K \times V \times Stot$

where:

Q = minimum supply of water in litres

K = water supply coefficient from Table 1

V = total building volume in cubic metres

Stot = total of spatial coefficient values from the property line exposures on all sides as obtained from the formula:

$Stot = 1.0 + [S_{side1} + S_{side2} + S_{side3} + \dots \text{etc.}]$

K	10	(from Table 1 pg A-31) (Worst case occupancy {E / F2} 'K' value used)
V	318,000	(Total building volume in m ³ .)
Stot	1.5	(From figure 1 pg A-32)
Q =	4,770,000.00 L	

				From Figure 1 (A-32)
Snorth	10.48	m	0.0	
Seast	126.50	m	0.0	
Ssouth	29.94	m	0.0	
Swest	3.17	m	0.5	

*approximate distances

From Table 2: Required Minimum Water Supply Flow Rate (L/s)

9000 L/min if $Q > 270,000 L$
2378 gpm

McINTOSH PERRY

CCO-21-2955 - 1919 Riverside Dr - Phase 1 - OBC Fire Calculations

Project:	1919 Riverside Dr - Phase II
Project No.:	CCO-21-2955
Designed By:	AJG
Checked By:	RDF
Date:	April 1, 2022

Ontario 2006 Building Code Compendium (Div. B - Part 3)

Water Supply for Fire-Fighting - Retirement & LTC Home

Building is classified as Group : **B** (from table 3.2.2.55)

Building is of noncombustible construction with fire separations and fire-resistance ratings provided in accordance with subsections 3.2.2., including loadbearing walls, columns and arches

From Div. B A-3.2.5.7. of the Ontario Building Code - 3. Building On-Site Water Supply:

(a) $Q = K \times V \times Stot$

where:

Q = minimum supply of water in litres

K = water supply coefficient from Table 1

V = total building volume in cubic metres

Stot = total of spatial coefficient values from the property line exposures on all sides as obtained from the formula:

$Stot = 1.0 + [S_{side1} + S_{side2} + S_{side3} + \dots \text{etc.}]$

K	10	(from Table 1 pg A-31) (Worst case occupancy {E / F2} 'K' value used)
V	1,464,499	(Total building volume in m ³ .)
Stot	1.5	(From figure 1 pg A-32)
Q =	21,967,487.16 L	

				From Figure 1 (A-32)
Snorth	36.97	m	0.0	
Seast	4	m	0.5	
Ssouth	27.9	m	0.0	
Swest	60.99	m	0.0	
				*approximate distances

From Table 2: Required Minimum Water Supply Flow Rate (L/s)

9000 L/min if $Q > 270,000 L$
2378 gpm

McINTOSH PERRY

CCO-21-2955 - 1919 Riverside Dr - Fire Underwriters Survey

Project: 1919 Riverside Dr
 Project No.: CCO-21-2955
 Designed By: AJG
 Checked By: RDF
 Date: April 1, 2022

From the Fire Underwriters Survey (1999)

From Part II – Guide for Determination of Required Fire Flow Copyright I.S.O.:
 Updated per City of Ottawa Technical Bulletin ISTB-2018-02

A. BASE REQUIREMENT (Rounded to the nearest 1000 L/min)

$F = 220 \times C \times \sqrt{A}$ Where:
F = Required fire flow in liters per minute
C = Coefficient related to the type of construction.
A = The total floor area in square meters (including all storey's, but excluding basements at least 50 percent below grade) in the building being considered.

Construction Type Non-Combustible Construction

C 0.8 A 15,493.0 m²

Calculated Fire Flow 21,906.9 L/min
 22,000.0 L/min

B. REDUCTION FOR OCCUPANCY TYPE (No Rounding)

From note 2, Page 18 of the Fire Underwriter Survey:
 Limited Combustible -15%

Fire Flow 18,700.0 L/min

C. REDUCTION FOR SPRINKLER TYPE (No Rounding)

Fully Supervised Sprinklered -50%

Reduction -9,350.0 L/min

D. INCREASE FOR EXPOSURE (No Rounding)

	Separation Distance (m)	Cons.of Exposed Wall	Length Exposed Adjacent Wall (m)	Height (Stories)	Length-Height Factor	
Exposure 1	>45					0%
Exposure 2	>45	Ordinary (Unprotected)	20	12	240.0	0%
Exposure 3	30.1 to 45	Wood frame	33	2	66.0	5%
Exposure 4	3.1 to 10	Ordinary (Unprotected)	29.6	4	118.4	19%
% Increase*						24%

Increase* 4,488.0 L/min

E. Total Fire Flow (Rounded to the Nearest 1000 L/min)

Fire Flow 13,838.0 L/min
 Fire Flow Required** 14,000.0 L/min

*In accordance with Part II, Section 4, the Increase for separation distance is not to exceed 75%

**In accordance with Section 4 the Fire flow is not to exceed 45,000 L/min or be less than 2,000 L/min

McINTOSH PERRY

CCO-21-2955 - 1919 Riverside Dr - Fire Underwriters Survey

Project: 1919 Riverside Dr
 Project No.: CCO-21-2955
 Designed By: AJG
 Checked By: RDF
 Date: April 1, 2022

From the Fire Underwriters Survey (1999)

From Part II – Guide for Determination of Required Fire Flow Copyright I.S.O.:
 Updated per City of Ottawa Technical Bulletin ISTB-2018-02

A. BASE REQUIREMENT (Rounded to the nearest 1000 L/min)

$F = 220 \times C \times \sqrt{A}$ Where:
F = Required fire flow in liters per minute
C = Coefficient related to the type of construction.
A = The total floor area in square meters (including all storey's, but excluding basements at least 50 percent below grade) in the building being considered.

Construction Type Non-Combustible Construction

C 0.8 A 44,383.0 m²

Calculated Fire Flow 37,078.4 L/min
 37,000.0 L/min

B. REDUCTION FOR OCCUPANCY TYPE (No Rounding)

From note 2, Page 18 of the Fire Underwriter Survey:
 Limited Combustible -15%

Fire Flow 31,450.0 L/min

C. REDUCTION FOR SPRINKLER TYPE (No Rounding)

Fully Supervised Sprinklered -50%

Reduction -15,725.0 L/min

D. INCREASE FOR EXPOSURE (No Rounding)

	Separation Distance (m)	Cons.of Exposed Wall	Length Exposed Adjacent Wall (m)	Height (Stories)	Length-Height Factor	
Exposure 1	>45					0%
Exposure 2	>45	Ordinary (Unprotected)	20	12	240.0	0%
Exposure 3	30.1 to 45	Wood frame	33	2	66.0	5%
Exposure 4	3.1 to 10	Ordinary (Unprotected)	29.6	4	118.4	19%
% Increase*						24%

Increase* 7,548.0 L/min

E. Total Fire Flow (Rounded to the Nearest 1000 L/min)

Fire Flow 23,273.0 L/min
 Fire Flow Required** 23,000.0 L/min

*In accordance with Part II, Section 4, the Increase for separation distance is not to exceed 75%
 **In accordance with Section 4 the Fire flow is not to exceed 45,000 L/min or be less than 2,000 L/min

McINTOSH PERRY

CCO-21-2955 - 1919 Riverside Dr - Boundary Condition Unit Conversion

Project: 1919 Riverside Dr
Project No.: CCO-21-2955
Designed By: AJG
Checked By: RDF
Date: April 1, 2022

Boundary Conditions Unit Conversion

Connection 1 (Smyth Road - North West)

Scenario	Height (m)	Elevation (m)	m H ₂ O	PSI	kPa
Avg. DD	118.9	65.8	53.1	75.6	520.9
Fire Flow (147 L/s or 8,820 L/min)	79.9	65.8	14.1	20	140
Peak Hour	107.6	65.8	41.8	59.5	410.1

Connection 2 (Balmoral Place - North East)

Scenario	Height (m)	Elevation (m)	m H ₂ O	PSI	kPa
Avg. DD	118.9	69.3	49.6	70.6	486.6
Fire Flow (147 L/s or 8,820 L/min)	83.4	69.3	14.1	20	140
Peak Hour	107.6	69.3	38.3	54.5	375.7

CCO-21-2955 - 1919 Riverside Drive - Model Output

Project:	1919 Riverside Drive
Project No.:	CCO-21-2955
Designed By:	A.J.G.
Checked By:	R.D.F.
Date:	April 1, 2022

MODEL INPUTS

Flow Units	L/s
Headloss Formula	H-W
Specific Gravity	1.0
Accuracy	0.001
Demand Multiplier	1.0
Maximum Fire Flow (L/s)	383.33
Fire Flow Per Hydrant (L/s)	127.8

MODEL LOSSES

Standard Tee - Flow through run	0.6
Standard Tee - Flow through branch	1.8
45 Degree Elbow	0.4
Long Radius Elbow	0.6
Short Radius Elbow	0.9
Gate valve, fully open	0.2
Swing check valve, fully open	2.5

MODEL RESULTS

Junctions	Average Daily Demand (kPa)	Maximum Daily Demand + Fire Flow (kPa)	Peak Hourly Demand (kPa)
J3	548.35	381.18	437.36
J4	567.66	447.76	456.87
J5	507.85	391.28	397.07
PROP	543.84	376.58	432.56
FH3	544.82	224.42	433.83
FH4	522.56	242.16	411.77
FH5	564.23	272.46	453.44

Junctions	Average Daily Demand (m)	Maximum Daily Demand + Fire Flow (m)	Peak Hourly Demand (m)
J3	55.93	38.88	44.61
J4	57.90	45.67	46.60
J5	51.80	39.91	40.50
PROP	55.47	38.41	44.12
FH3	55.57	22.89	44.25
FH4	53.30	24.7	42.00
FH5	57.55	27.79	46.25

**EPANET WATER MODEL
AVERAGE DAY SCENARIO**

1919 RIVERSIDE DRIVE AVERAGE DEMAND

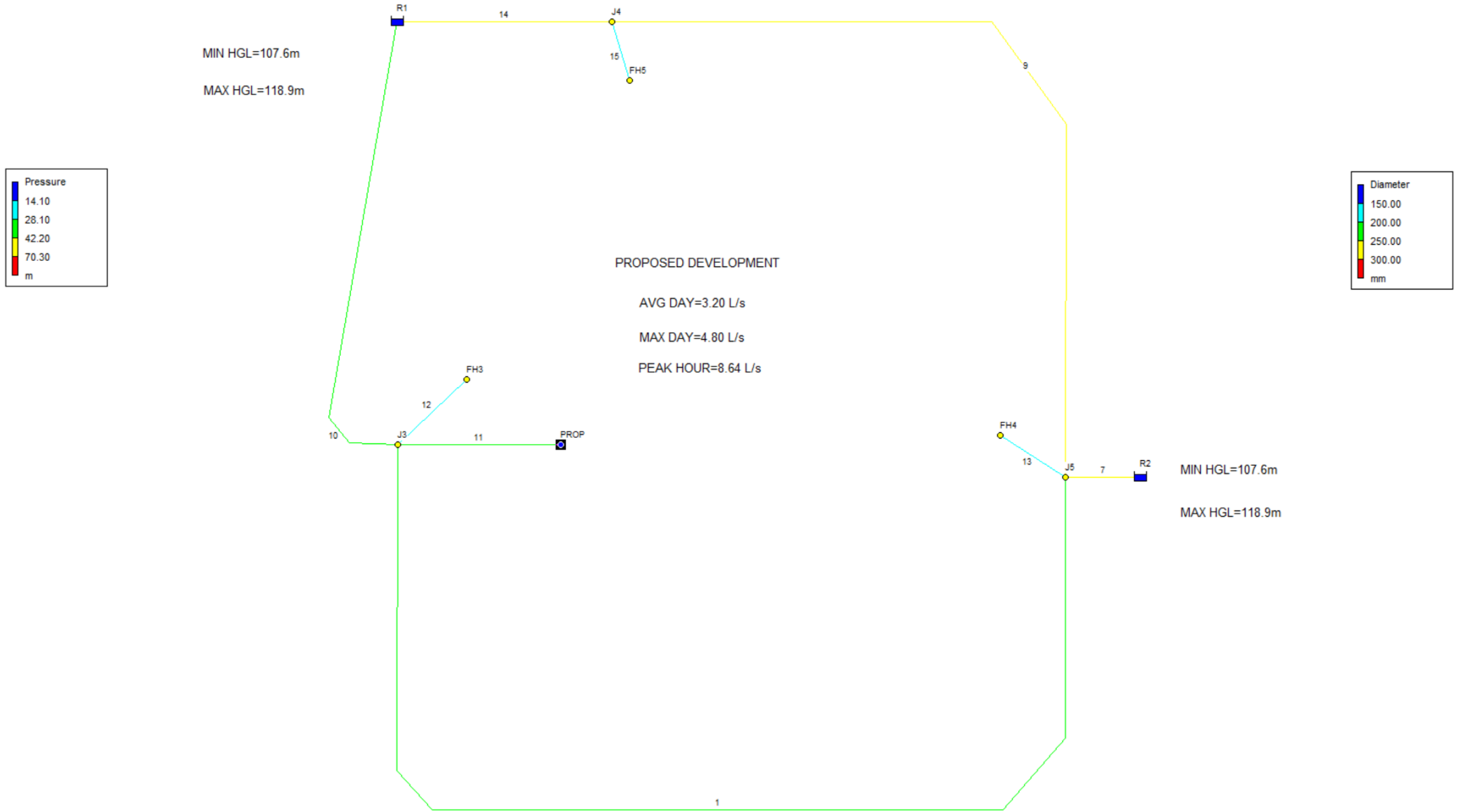

[TITLE]

[JUNCTIONS]

;ID	Elev	Demand	Pattern	
J5	67.1	0		;
J3	62.96	0		;
PROP	63.42	3.2		;
FH5	61.35	0		;
FH3	63.32	0		;
J4	61	0		;
FH4	65.60	0		;

[RESERVOIRS]

;ID	Head	Pattern	
R2	118.9		;
R1	118.9		;

[TANKS]

;ID	Diameter	Elevation MinVol	InitLevel VolCurve	MinLevel Overflow	MaxLevel
-----	----------	---------------------	-----------------------	----------------------	----------

[PIPES]

;ID	Diameter	Node1 Roughness	MinorLoss	Node2	Status	Length
7	254	J5 110	0.6	R2	Open ;	1
9	254	J5 110	4	J4	Open ;	135.4
10	203	R1 110	1.8	J3	Open ;	124.07
11	203	PROP 110	0.6	J3	Open ;	35.7
12	152	FH3 100	5.9	J3	Open ;	1.6
13	152	FH4 100	5.9	J5	Open ;	4
14	254	J4 110	1.2	R1	Open ;	37
15	152	J4 100	5.9	FH5	Open ;	5.8
1	203	J3 110	4.8	J5	Open ;	286.9

[PUMPS]

;ID	Node1	Node2	Parameters
-----	-------	-------	------------

[VALVES]

;ID	Type	Setting	Node1 MinorLoss	Node2	Diameter
-----	------	---------	--------------------	-------	----------

[TAGS]

[DEMANDS]

;Junction Demand Pattern Category

[STATUS]

;ID Status/Setting

[PATTERNS]

;ID Multipliers

[CURVES]

;ID X-Value Y-Value

[CONTROLS]

[RULES]

[ENERGY]

Global Efficiency 75
Global Price 0
Demand Charge 0

[EMITTERS]

;Junction Coefficient

[QUALITY]

;Node InitQual

[SOURCES]

;Node Type Quality Pattern

[REACTIONS]

;Type Pipe/Tank Coefficient

[REACTIONS]

Order Bulk 1
Order Tank 1
Order Wall 1
Global Bulk 0
Global Wall 0
Limiting Potential 0
Roughness Correlation 0

[MIXING]

;Tank Model

[TIMES]

Duration	0
Hydraulic Timestep	1:00
Quality Timestep	0:05
Pattern Timestep	1:00
Pattern Start	0:00
Report Timestep	1:00
Report Start	0:00
Start ClockTime	12 am
Statistic	None

[REPORT]

Status	No
Summary	No
Page	0

[OPTIONS]

Units	LPS
Headloss	H-W
Specific Gravity	1
Viscosity	1
Trials	40
Accuracy	0.001
CHECKFREQ	2
MAXCHECK	10
DAMPLIMIT	0
Unbalanced	Continue 10
Pattern	1
Demand Multiplier	1.0
Emitter Exponent	0.5
Quality	None mg/L
Diffusivity	1
Tolerance	0.01

[COORDINATES]

;Node	X-Coord	Y-Coord
J5	6205.251	6372.315
J3	501.193	6650.756
PROP	1893.397	6650.756
FH5	2482.100	9761.337
FH3	1089.897	7207.637
J4	2334.602	10265.462
FH4	5648.369	6730.310
R2	6841.687	6372.315
R1	495.156	10264.992

[VERTICES]

;Link	X-Coord	Y-Coord
9	6214.220	9384.279
9	5578.768	10264.992
10	-88.652	6879.433

10	88.652	6666.667
1	493.238	3866.348
1	795.545	3532.220
1	5672.235	3532.220
1	6205.251	4144.789

[LABELS]

;X-Coord	Y-Coord	Label & Anchor Node
7191.726	6499.602	"MIN HGL=107.6m"
7191.726	6133.652	"MAX HGL=118.9m"
-1161.496	10055.688	"MIN HGL=107.6m"
-1153.540	9737.470	"MAX HGL=118.9m"
2362.768	8265.712	"PROPOSED DEVELOPMENT"
2569.610	7923.628	"AVG DAY=3.20 L/s"
2569.610	7629.276	"MAX DAY=4.80 L/s"
2559.102	7364.066	"PEAK HOUR=8.64 L/s"

[BACKDROP]

DIMENSIONS	0.000	0.000	10000.000
10000.000			
UNITS	None		
FILE			
OFFSET	0.00	0.00	

[END]

```

*****
*                               E P A N E T                               *
*                               Hydraulic and Water Quality              *
*                               Analysis for Pipe Networks                *
*                               Version 2.2                              *
*****
    
```

Input File: 2022-03-30_avgday.net

Link - Node Table:

Link ID	Start Node	End Node	Length m	Diameter mm
7	J5	R2	1	254
9	J5	J4	135.4	254
10	R1	J3	124.07	203
11	PROP	J3	35.7	203
12	FH3	J3	1.6	152
13	FH4	J5	4	152
14	J4	R1	37	254
15	J4	FH5	5.8	152
1	J3	J5	286.9	203

Node Results:

Node ID	Demand LPS	Head m	Pressure m	Quality
J5	0.00	118.90	51.80	0.00
J3	0.00	118.89	55.93	0.00
PROP	3.20	118.89	55.47	0.00
FH5	0.00	118.90	57.55	0.00
FH3	0.00	118.89	55.57	0.00
J4	0.00	118.90	57.90	0.00
FH4	0.00	118.90	53.30	0.00
R2	-1.10	118.90	0.00	0.00 Reservoir
R1	-2.10	118.90	0.00	0.00 Reservoir

Link Results:

Link ID	Flow LPS	Velocity m/s	Headloss m/km	Status
7	-1.10	0.02	0.02	Open
9	-0.14	0.00	0.00	Open
10	1.96	0.06	0.04	Open

11	-3.20	0.10	0.11	Open
12	0.00	0.00	0.00	Open
13	0.00	0.00	0.00	Open
14	-0.14	0.00	0.00	Open



Page 2

Link Results: (continued)

Link ID	Flow LPS	Velocity m/s	Unit Headloss m/km	Status
15	0.00	0.00	0.00	Open
1	-1.24	0.04	0.02	Open

**EPANET WATER MODEL
MAX DAY + FIRE FLOW SCENARIO**

1919 RIVERSIDE DRIVE MAX DAY + FIRE FLOW DEMAND

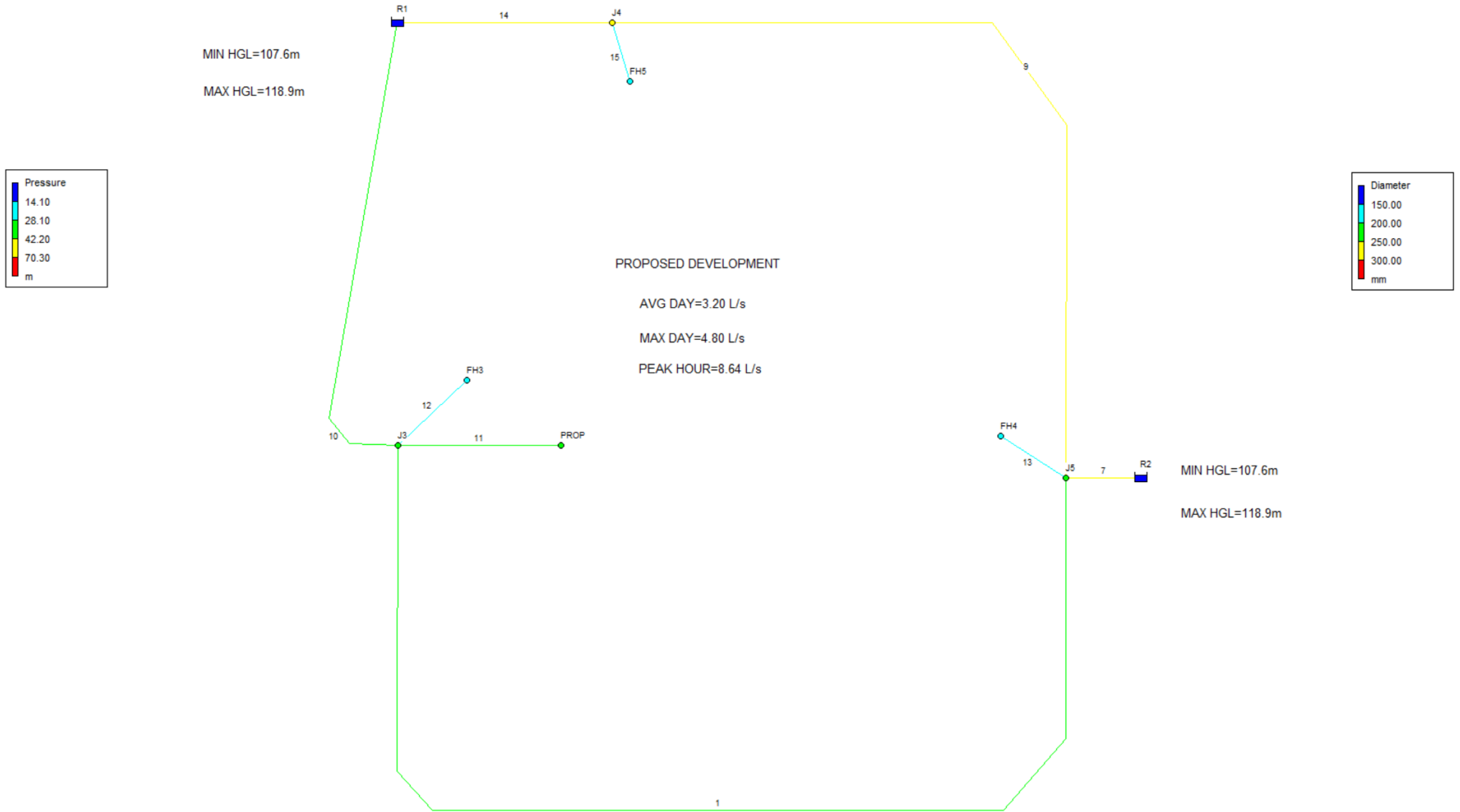

[TITLE]

[JUNCTIONS]

;ID	Elev	Demand	Pattern	
J5	67.1	0		;
J3	62.96	0		;
PROP	63.42	4.8		;
FH5	61.35	127.8		;
FH3	63.32	127.8		;
J4	61	0		;
FH4	65.60	127.8		;

[RESERVOIRS]

;ID	Head	Pattern	
R2	107.6		;
R1	107.6		;

[TANKS]

;ID	Diameter	Elevation MinVol	InitLevel VolCurve	MinLevel Overflow	MaxLevel
-----	----------	---------------------	-----------------------	----------------------	----------

[PIPES]

;ID	Diameter	Node1 Roughness	MinorLoss	Node2	Status	Length
7	254	J5 110	0.6	R2	Open ;	1
9	254	J5 110	4	J4	Open ;	135.4
10	203	R1 110	1.8	J3	Open ;	124.07
11	203	PROP 110	0.6	J3	Open ;	35.7
12	152	FH3 100	5.9	J3	Open ;	1.6
13	152	FH4 100	5.9	J5	Open ;	4
14	254	J4 110	1.2	R1	Open ;	37
15	152	J4 100	5.9	FH5	Open ;	5.8
1	203	J3 110	4.8	J5	Open ;	286.9

[PUMPS]

;ID	Node1	Node2	Parameters
-----	-------	-------	------------

[VALVES]

;ID	Type	Setting	Node1 MinorLoss	Node2	Diameter
-----	------	---------	--------------------	-------	----------

[TAGS]

[DEMANDS]

;Junction Demand Pattern Category

[STATUS]

;ID Status/Setting

[PATTERNS]

;ID Multipliers

[CURVES]

;ID X-Value Y-Value

[CONTROLS]

[RULES]

[ENERGY]

Global Efficiency 75
Global Price 0
Demand Charge 0

[EMITTERS]

;Junction Coefficient

[QUALITY]

;Node InitQual

[SOURCES]

;Node Type Quality Pattern

[REACTIONS]

;Type Pipe/Tank Coefficient

[REACTIONS]

Order Bulk 1
Order Tank 1
Order Wall 1
Global Bulk 0
Global Wall 0
Limiting Potential 0
Roughness Correlation 0

[MIXING]

;Tank Model

[TIMES]

Duration	0
Hydraulic Timestep	1:00
Quality Timestep	0:05
Pattern Timestep	1:00
Pattern Start	0:00
Report Timestep	1:00
Report Start	0:00
Start ClockTime	12 am
Statistic	None

[REPORT]

Status	No
Summary	No
Page	0

[OPTIONS]

Units	LPS
Headloss	H-W
Specific Gravity	1
Viscosity	1
Trials	40
Accuracy	0.001
CHECKFREQ	2
MAXCHECK	10
DAMPLIMIT	0
Unbalanced	Continue 10
Pattern	1
Demand Multiplier	1.0
Emitter Exponent	0.5
Quality	None mg/L
Diffusivity	1
Tolerance	0.01

[COORDINATES]

;Node	X-Coord	Y-Coord
J5	6205.251	6372.315
J3	501.193	6650.756
PROP	1893.397	6650.756
FH5	2482.100	9761.337
FH3	1089.897	7207.637
J4	2334.602	10265.462
FH4	5648.369	6730.310
R2	6841.687	6372.315
R1	495.156	10264.992

[VERTICES]

;Link	X-Coord	Y-Coord
9	6214.220	9384.279
9	5578.768	10264.992
10	-88.652	6879.433

10	88.652	6666.667
1	493.238	3866.348
1	795.545	3532.220
1	5672.235	3532.220
1	6205.251	4144.789

[LABELS]

;X-Coord	Y-Coord	Label & Anchor Node
7191.726	6499.602	"MIN HGL=107.6m"
7191.726	6133.652	"MAX HGL=118.9m"
-1161.496	10055.688	"MIN HGL=107.6m"
-1153.540	9737.470	"MAX HGL=118.9m"
2362.768	8265.712	"PROPOSED DEVELOPMENT"
2569.610	7923.628	"AVG DAY=3.20 L/s"
2569.610	7629.276	"MAX DAY=4.80 L/s"
2559.102	7364.066	"PEAK HOUR=8.64 L/s"

[BACKDROP]

DIMENSIONS	0.000	0.000	10000.000
10000.000			
UNITS	None		
FILE			
OFFSET	0.00	0.00	

[END]

```

*****
*                               E P A N E T                               *
*                               Hydraulic and Water Quality              *
*                               Analysis for Pipe Networks                *
*                               Version 2.2                              *
*****
    
```

Input File: 2022-03-30_maxdayfireflow.net

Link - Node Table:

Link ID	Start Node	End Node	Length m	Diameter mm
7	J5	R2	1	254
9	J5	J4	135.4	254
10	R1	J3	124.07	203
11	PROP	J3	35.7	203
12	FH3	J3	1.6	152
13	FH4	J5	4	152
14	J4	R1	37	254
15	J4	FH5	5.8	152
1	J3	J5	286.9	203

Node Results:

Node ID	Demand LPS	Head m	Pressure m	Quality
J5	0.00	107.01	39.91	0.00
J3	0.00	101.84	38.88	0.00
PROP	4.80	101.83	38.41	0.00
FH5	127.80	89.14	27.79	0.00
FH3	127.80	86.21	22.89	0.00
J4	0.00	106.67	45.67	0.00
FH4	127.80	90.30	24.70	0.00
R2	-206.99	107.60	0.00	0.00 Reservoir
R1	-181.21	107.60	0.00	0.00 Reservoir

Link Results:

Link ID	Flow LPS	Velocity m/s	Headloss m/km	Status
7	-206.99	4.09	585.80	Open
9	29.58	0.58	2.58	Open
10	82.99	2.56	46.41	Open

11	-4.80	0.15	0.23	Open
12	-127.80	7.04	9768.55	Open
13	-127.80	7.04	4178.26	Open
14	-98.22	1.94	25.26	Open



Page 2

Link Results: (continued)

Link ID	Flow LPS	Velocity m/s	Unit Headloss m/km	Status
15	127.80	7.04	3021.65	Open
1	-49.61	1.53	18.03	Open

**EPANET WATER MODEL
PEAK HOUR SCENARIO**

1919 RIVERSIDE DRIVE PEAK HOUR DEMAND

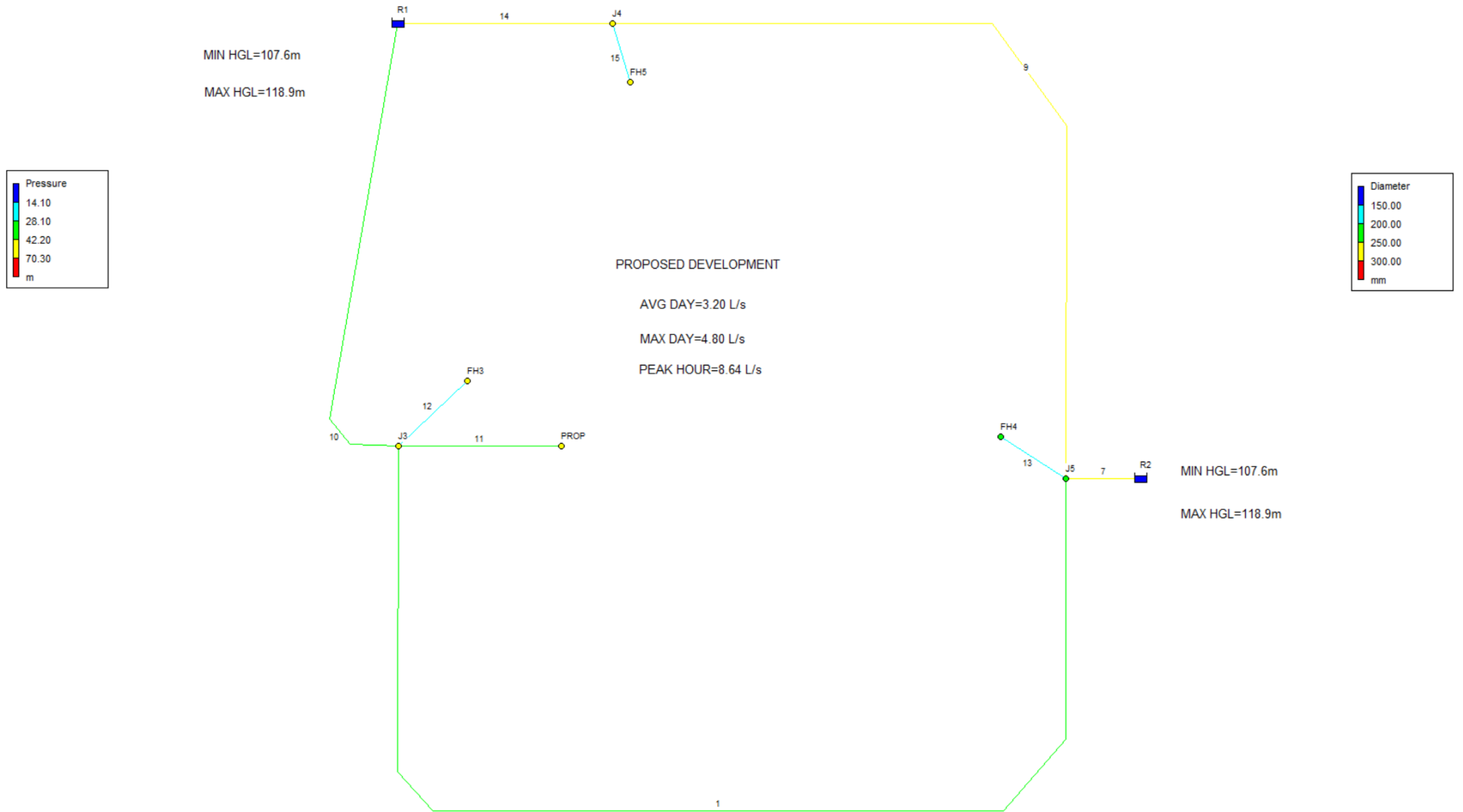

[TITLE]

[JUNCTIONS]

;ID	Elev	Demand	Pattern	
J5	67.1	0		;
J3	62.96	0		;
PROP	63.42	8.64		;
FH5	61.35	0		;
FH3	63.32	0		;
J4	61	0		;
FH4	65.60	0		;

[RESERVOIRS]

;ID	Head	Pattern	
R2	107.6		;
R1	107.6		;

[TANKS]

;ID	Diameter	Elevation MinVol	InitLevel VolCurve	MinLevel Overflow	MaxLevel
-----	----------	---------------------	-----------------------	----------------------	----------

[PIPES]

;ID	Diameter	Node1 Roughness	MinorLoss	Node2	Status	Length
7	254	J5 110	0.6	R2	Open ;	1
9	254	J5 110	4	J4	Open ;	135.4
10	203	R1 110	1.8	J3	Open ;	124.07
11	203	PROP 110	0.6	J3	Open ;	35.7
12	152	FH3 100	5.9	J3	Open ;	1.6
13	152	FH4 100	5.9	J5	Open ;	4
14	254	J4 110	1.2	R1	Open ;	37
15	152	J4 100	5.9	FH5	Open ;	5.8
1	203	J3 110	4.8	J5	Open ;	286.9

[PUMPS]

;ID	Node1	Node2	Parameters
-----	-------	-------	------------

[VALVES]

;ID	Type	Setting	Node1 MinorLoss	Node2	Diameter
-----	------	---------	--------------------	-------	----------

[TAGS]

[DEMANDS]
;Junction Demand Pattern Category

[STATUS]
;ID Status/Setting

[PATTERNS]
;ID Multipliers

[CURVES]
;ID X-Value Y-Value

[CONTROLS]

[RULES]

[ENERGY]
Global Efficiency 75
Global Price 0
Demand Charge 0

[EMITTERS]
;Junction Coefficient

[QUALITY]
;Node InitQual

[SOURCES]
;Node Type Quality Pattern

[REACTIONS]
;Type Pipe/Tank Coefficient

[REACTIONS]
Order Bulk 1
Order Tank 1
Order Wall 1
Global Bulk 0
Global Wall 0
Limiting Potential 0
Roughness Correlation 0

[MIXING]
;Tank Model

[TIMES]

Duration 0
Hydraulic Timestep 1:00
Quality Timestep 0:05
Pattern Timestep 1:00
Pattern Start 0:00
Report Timestep 1:00
Report Start 0:00
Start ClockTime 12 am
Statistic None

[REPORT]

Status No
Summary No
Page 0

[OPTIONS]

Units LPS
Headloss H-W
Specific Gravity 1
Viscosity 1
Trials 40
Accuracy 0.001
CHECKFREQ 2
MAXCHECK 10
DAMPLIMIT 0
Unbalanced Continue 10
Pattern 1
Demand Multiplier 1.0
Emitter Exponent 0.5
Quality None mg/L
Diffusivity 1
Tolerance 0.01

[COORDINATES]

;Node	X-Coord	Y-Coord
J5	6205.251	6372.315
J3	501.193	6650.756
PROP	1893.397	6650.756
FH5	2482.100	9761.337
FH3	1089.897	7207.637
J4	2334.602	10265.462
FH4	5648.369	6730.310
R2	6841.687	6372.315
R1	495.156	10264.992

[VERTICES]

;Link	X-Coord	Y-Coord
9	6214.220	9384.279
9	5578.768	10264.992
10	-88.652	6879.433

10	88.652	6666.667
1	493.238	3866.348
1	795.545	3532.220
1	5672.235	3532.220
1	6205.251	4144.789

[LABELS]

;X-Coord	Y-Coord	Label & Anchor Node
7191.726	6499.602	"MIN HGL=107.6m"
7191.726	6133.652	"MAX HGL=118.9m"
-1161.496	10055.688	"MIN HGL=107.6m"
-1153.540	9737.470	"MAX HGL=118.9m"
2362.768	8265.712	"PROPOSED DEVELOPMENT"
2569.610	7923.628	"AVG DAY=3.20 L/s"
2569.610	7629.276	"MAX DAY=4.80 L/s"
2559.102	7364.066	"PEAK HOUR=8.64 L/s"

[BACKDROP]

DIMENSIONS	0.000	0.000	10000.000
10000.000			
UNITS	None		
FILE			
OFFSET	0.00	0.00	

[END]

```

*****
*                               E P A N E T                               *
*                               Hydraulic and Water Quality                *
*                               Analysis for Pipe Networks                  *
*                               Version 2.2                                *
*****
    
```

Input File: 2022-03-30_peakhour.net

Link - Node Table:

Link ID	Start Node	End Node	Length m	Diameter mm
7	J5	R2	1	254
9	J5	J4	135.4	254
10	R1	J3	124.07	203
11	PROP	J3	35.7	203
12	FH3	J3	1.6	152
13	FH4	J5	4	152
14	J4	R1	37	254
15	J4	FH5	5.8	152
1	J3	J5	286.9	203

Node Results:

Node ID	Demand LPS	Head m	Pressure m	Quality
J5	0.00	107.60	40.50	0.00
J3	0.00	107.57	44.61	0.00
PROP	8.64	107.54	44.12	0.00
FH5	0.00	107.60	46.25	0.00
FH3	0.00	107.57	44.25	0.00
J4	0.00	107.60	46.60	0.00
FH4	0.00	107.60	42.00	0.00
R2	-2.96	107.60	0.00	0.00 Reservoir
R1	-5.68	107.60	0.00	0.00 Reservoir

Link Results:

Link ID	Flow LPS	Velocity m/s	Headloss m/km	Status
7	-2.96	0.06	0.13	Open
9	-0.39	0.01	0.00	Open
10	5.29	0.16	0.27	Open

11	-8.64	0.27	0.69	Open
12	0.00	0.00	0.00	Open
13	0.00	0.00	0.00	Open
14	-0.39	0.01	0.00	Open



Page 2

Link Results: (continued)

Link ID	Flow LPS	Velocity m/s	Unit Headloss m/km	Status
15	0.00	0.00	0.00	Open
1	-3.35	0.10	0.12	Open

City of Ottawa - Water Distribution System Facilities & Feeder mains

ET STREET P.S.

HURDMAN P.S.

BILLINGS BRIDGE P.S.

CARLINGTON HEIGHTS P.S. & RES.

CONROY RD ELEVATED TANK

SUBJECT SITE

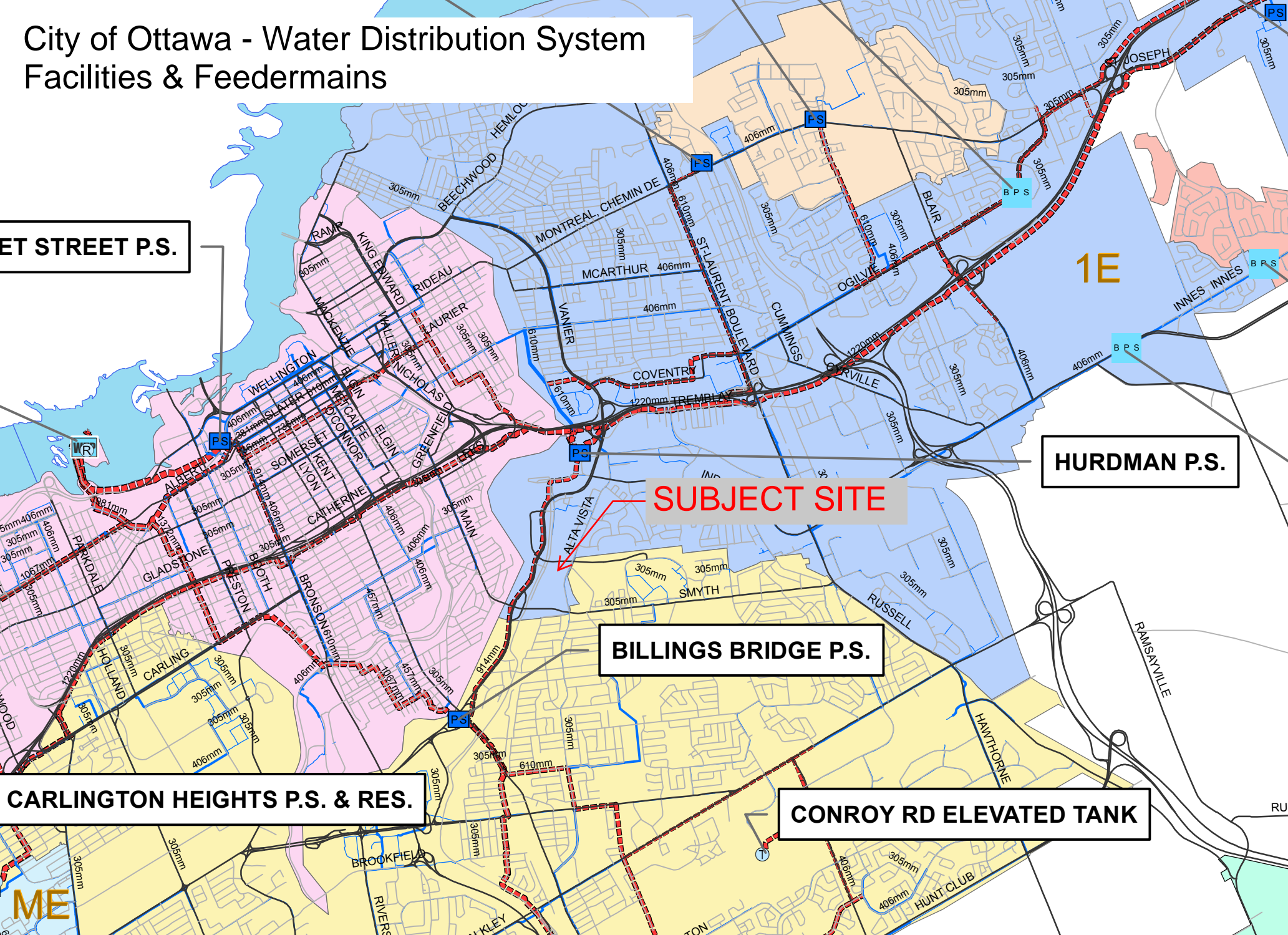

Alison Gosling

From: Harrold, Eric <eric.harrold@ottawa.ca>
Sent: October 29, 2021 11:37 AM
To: Alison Gosling
Cc: Robert Freel
Subject: RE: 21-2955 - 1919 Riverside - Boundary Condition Request
Attachments: 1919 Riverside Drive October 2021.pdf

Follow Up Flag: Follow up
Flag Status: Completed

Hi Alison,

Please see the below water boundary condition for 1919 Riverside Drive:

The following are boundary conditions, HGL, for hydraulic analysis at 1919 Riverside Drive (zone 1E) assumed to be a dual connection to the 254 mm at Smyth Road and Balmoral Place (see attached PDF for location).

Both Connections:

Minimum HGL: 107.6 m

Maximum HGL: 118.9 m

Available Fire Flow at 20 psi (Connection 1): 147 L/s, assuming a ground elevation of 65.8 m.

Available Fire Flow at 20 psi (Connection 2): 147 L/s, assuming a ground elevation of 69.3 m.

These are for current conditions and are based on computer model simulation.

Disclaimer: The boundary condition information is based on current operation of the city water distribution system. The computer model simulation is based on the best information available at the time. The operation of the water distribution system can change on a regular basis, resulting in a variation in boundary conditions. The physical properties of watermains deteriorate over time, as such must be assumed in the absence of actual field test data. The variation in physical watermain properties can therefore alter the results of the computer model simulation.

Best regards,

Eric
Eric Harrold, P.Eng
Planning, Infrastructure and Economic Development Department - Services de la Planification, de l'Infrastructure et du Développement Économique
Development Review
City of Ottawa | Ville d'Ottawa
110 Laurier Avenue West, Ottawa, ON | 110, Avenue. Laurier Ouest, Ottawa (Ontario) K1P 1J1
613.580.2424 ext./poste 21447, eric.harrold@ottawa.ca

Boundary Conditions for 1919 Riverside Drive

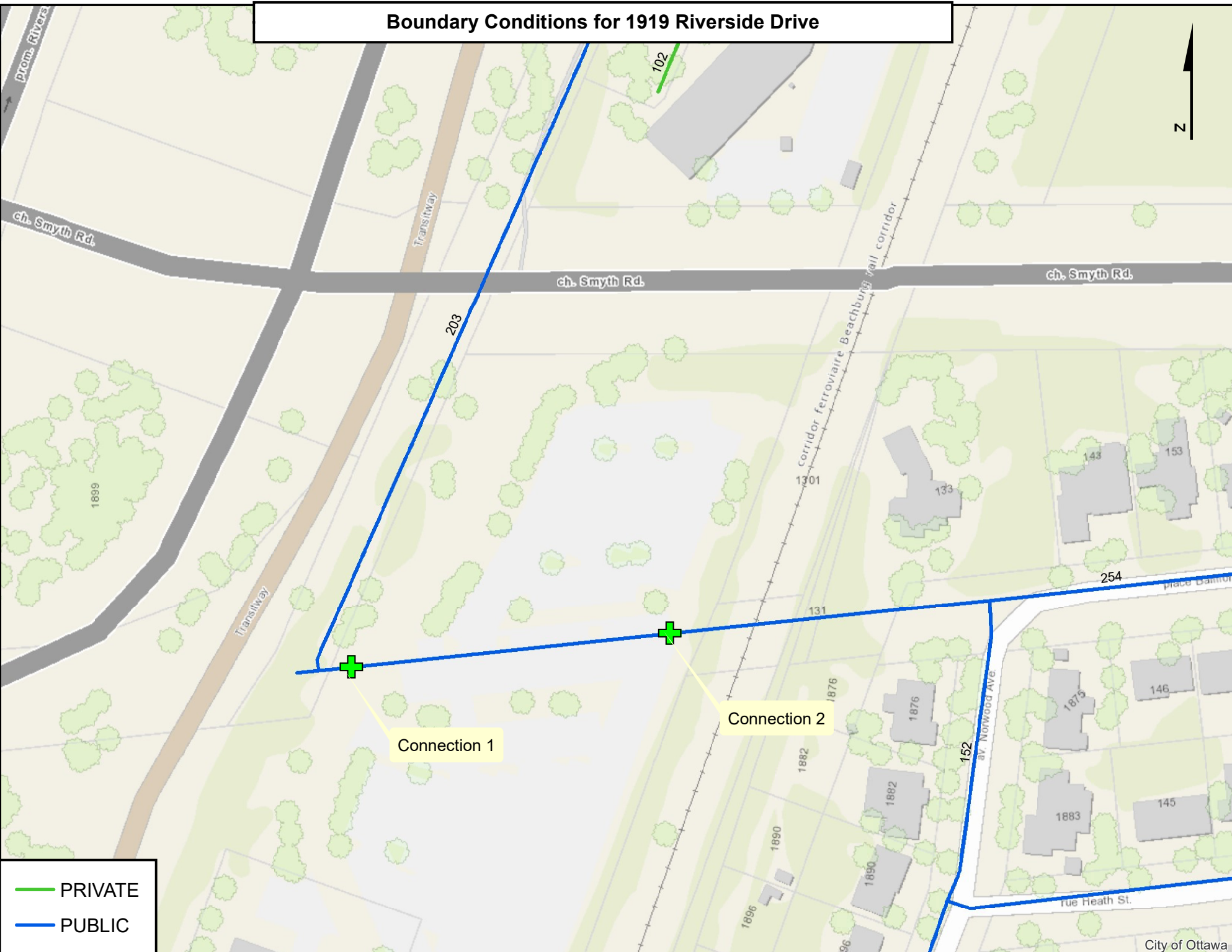
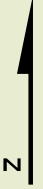

- PRIVATE
- PUBLIC

1919 Riverside Drive Hydrant Coverage Figure

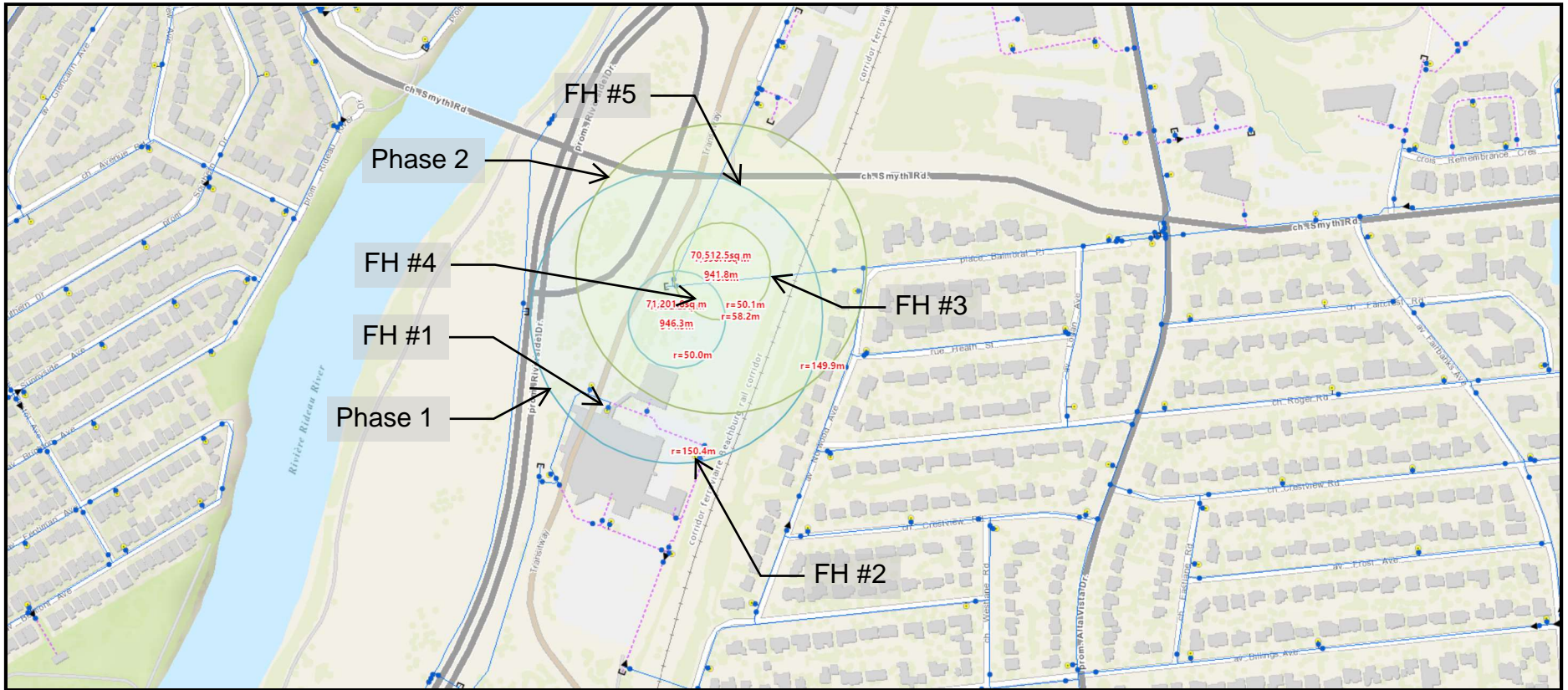

APPENDIX D
SANITARY CALCULATIONS

McINTOSH PERRY

CCO-21-2955 - 1919 Riverside Dr - Phase 1 - Sanitary Demands

Project:	1919 Riverside Dr - Phase 1	
Project No.:	CCO-21-2955	
Designed By:	AJG	
Checked By:	RDF	
Date:	Oct-21	
Site Area	2.01	Gross ha
LTC Home	256	beds
LTC Home Staff	85	persons
Commercial Area	0.00	m ²
Amenity Space	0.00	m ²

DESIGN PARAMETERS

Institutional/Commercial Peaking Factor	1.5	
Residential Peaking Factor	3.80	* Using Harmon Formula = $1+(14/(4+P^{0.5})) * 0.8$ where P = population in thousands, Harmon's Correction Factor = 0.8
Mannings coefficient (n)	0.013	
Demand (per capita)	280	L/day
Infiltration allowance	0.33	L/s/Ha

EXTRANEOUS FLOW ALLOWANCES

Infiltration / Inflow	Flow (L/s)
Dry	0.10
Wet	0.56
Total	0.66

AVERAGE DAILY DEMAND

DEMAND TYPE	AMOUNT	UNITS	POPULATION / AREA	Flow (L/s)
Residential	280	L/c/d		0
Industrial - Light**	35,000	L/gross ha/d		0
Industrial - Heavy**	55,000	L/gross ha/d		0
Commercial / Amenity	2,800	L/(1000m ² /d)		0
Nursing Homes & Rest Homes	450	L/(bed/d)	256	1.33
Medical Office - Doctors, Nurses & Medical Staff	275	L/(Person/d)	85	0.27
Tourist Commercial	28,000	L/gross ha/d		0
Other Commercial	28,000	L/gross ha/d		0

AVERAGE FLOW	1.60	L/s
PEAK FLOW	2.41	L/s
PEAK INDUSTRIAL FLOW	0.00	L/s
TOTAL PEAK ICI FLOW	2.41	L/s

TOTAL SANITARY DEMAND

TOTAL ESTIMATED AVERAGE DRY WEATHER FLOW	1.70	L/s
TOTAL ESTIMATED PEAK DRY WEATHER FLOW	2.51	L/s
TOTAL ESTIMATED PEAK WET WEATHER FLOW	3.07	L/s

McINTOSH PERRY

CCO-21-2955 - 1919 Riverside Dr - Phase 2 - Sanitary Demands

Project:	1919 Riverside Dr - Phase 2
Project No.:	CCO-21-2955
Designed By:	AJG
Checked By:	RDF
Date:	Oct-21

Site Area	2.01	Gross ha
LTC Home	256	beds
LTC Home Staff	85	persons
Retirement Home	270	beds
Retirement Home Staff	60	persons
Commercial Area	0.00	m ²
Amenity Space	0.00	m ²

DESIGN PARAMETERS

Institutional/Commercial Peaking Factor	1.5	
Residential Peaking Factor	3.80	* Using Harmon Formula = $1 + (14 / (4 + P^{0.5})) * 0.8$ where P = population in thousands, Harmon's Correction Factor = 0.8
Mannings coefficient (n)	0.013	
Demand (per capita)	280	L/day
Infiltration allowance	0.33	L/s/Ha

EXTRANEOUS FLOW ALLOWANCES

Infiltration / Inflow	Flow (L/s)
Dry	0.10
Wet	0.56
Total	0.66

AVERAGE DAILY DEMAND

DEMAND TYPE	AMOUNT	UNITS	POPULATION / AREA	Flow (L/s)
Residential	280	L/c/d		0
Industrial - Light**	35,000	L/gross ha/d		0
Industrial - Heavy**	55,000	L/gross ha/d		0
Commercial / Amenity	2,800	L/(1000m ² /d)		0
Nursing Homes & Rest Homes	450	L/(bed/d)	526	2.74
Medical Office - Doctors, Nurses & Medical Staff	275	L/(Person/d)	145	0.46
Tourist Commercial	28,000	L/gross ha/d		0
Other Commercial	28,000	L/gross ha/d		0

AVERAGE FLOW	3.20	L/s
PEAK FLOW	4.80	L/s
PEAK INDUSTRIAL FLOW	0.00	L/s
TOTAL PEAK ICI FLOW	4.80	L/s

TOTAL SANITARY DEMAND

TOTAL ESTIMATED AVERAGE DRY WEATHER FLOW	3.30	L/s
TOTAL ESTIMATED PEAK DRY WEATHER FLOW	4.90	L/s
TOTAL ESTIMATED PEAK WET WEATHER FLOW	5.47	L/s

**APPENDIX E
PRE-DEVELOPMENT DRAINAGE PLAN**

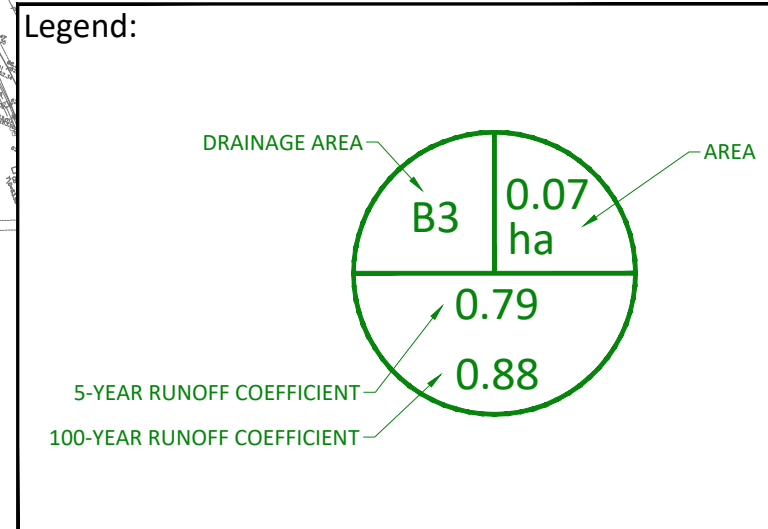
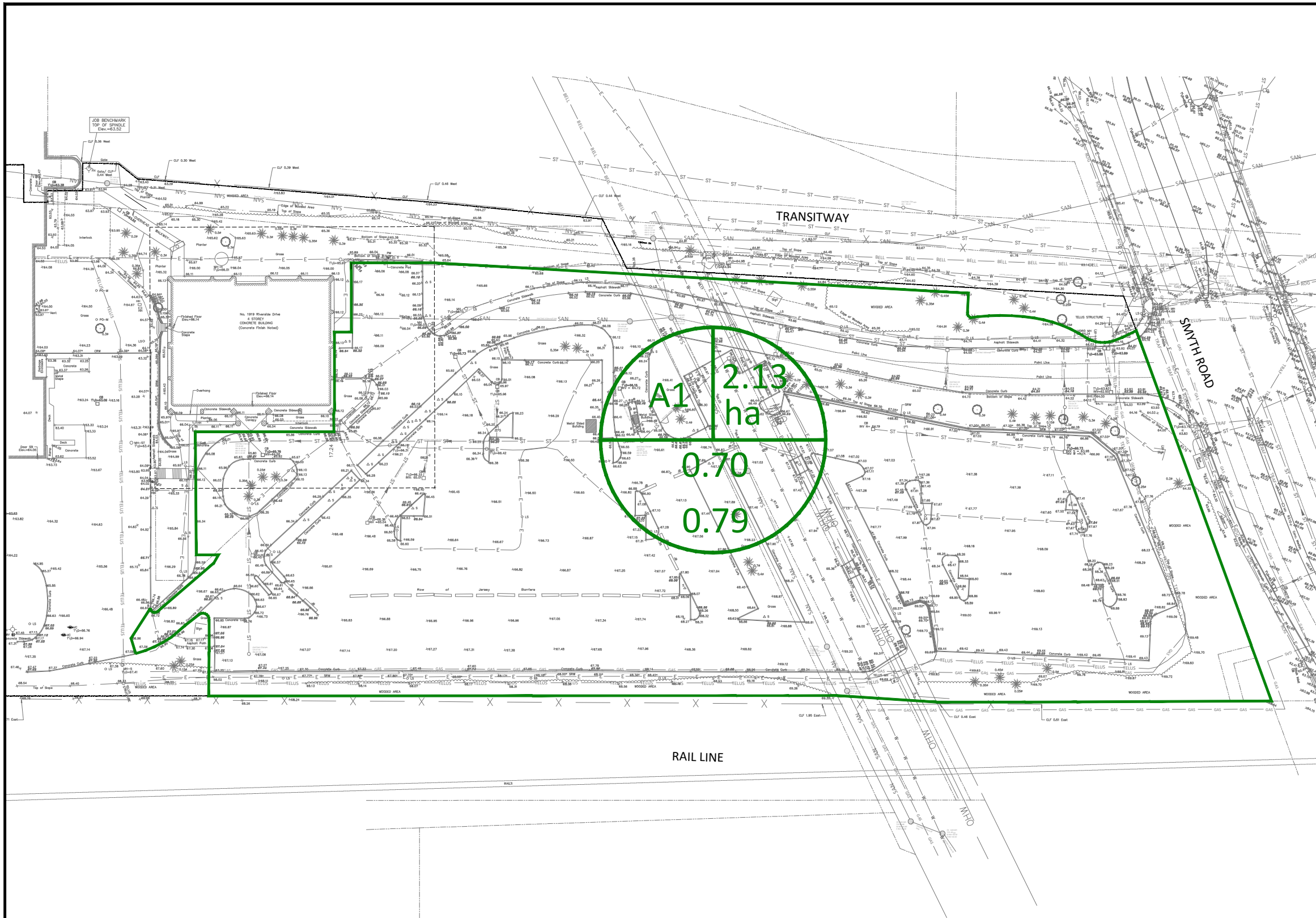

FILENAME: U:\Ottawa\01 - Projects - Proposals\2021 Jobs\CCO\CCO-21-2955 Cornerstone_Schlegel Villages_1919 Riverside Dr\Civil\12 - Drawings\CCO-21-2955 - Presentation.dwg
 User: r.d.fresl
 LAST PLOTTED: Thursday, April 07, 2022, 10:15:55 AM

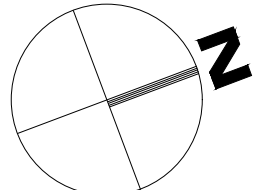
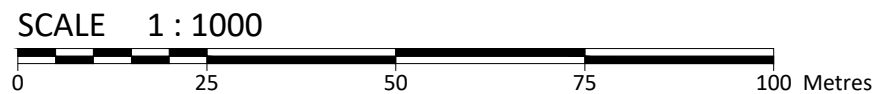

McINTOSH PERRY
 115 Walgreen Road, RR3, Carp, ON K0A 1L0
 Tel: 613-836-2184 Fax: 613-836-3742
 www.mcintoshperry.com

Client:		RBJ SCHLEGEL HOLDINGS 325 MAX BECKER DRIVE SUITE 201 KITCHENER, ON N2E 4H5	
Project:		LONG TERM CARE HOME 1919 RIVERSIDE DRIVE	
Drawing Title:		PRE-DEVELOPMENT DRAINAGE AREA PLAN	
Drawn by:	Checked By:	Drawing Number:	
R.R.R.	A.J.G.	2	ISSUED FOR REVIEW
Scale:	Project Number:	1	ISSUED FOR REVIEW
1:1000	CCO-21-2955		
No.	Revisions		Date

PRE

APPENDIX F
POST-DEVELOPMENT DRAINAGE PLAN

FILENAME: U:\Ottawa\01 Project - Proposals\2021 jobs\CCO\CCO-21-2955 Cornerstone_Schlegel Villages_1919 Riverside Dr\Civil\12 - Drawings\CCO-21-2955 - Presentations.dwg
 LAST PLOTTED: Friday, April 08, 2022 11:08:00 AM
 LAST FILE USED: ...

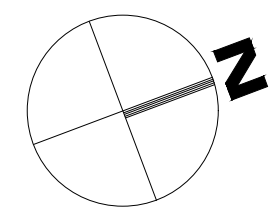
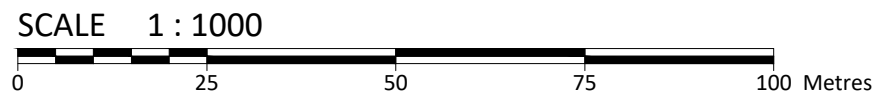
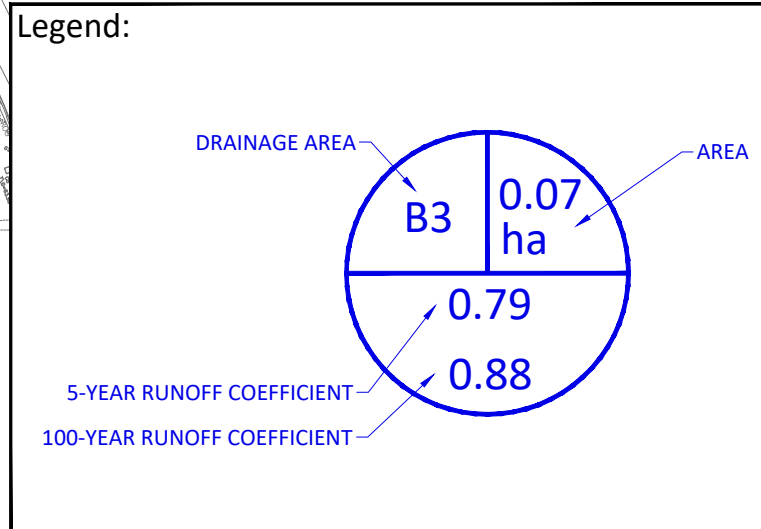
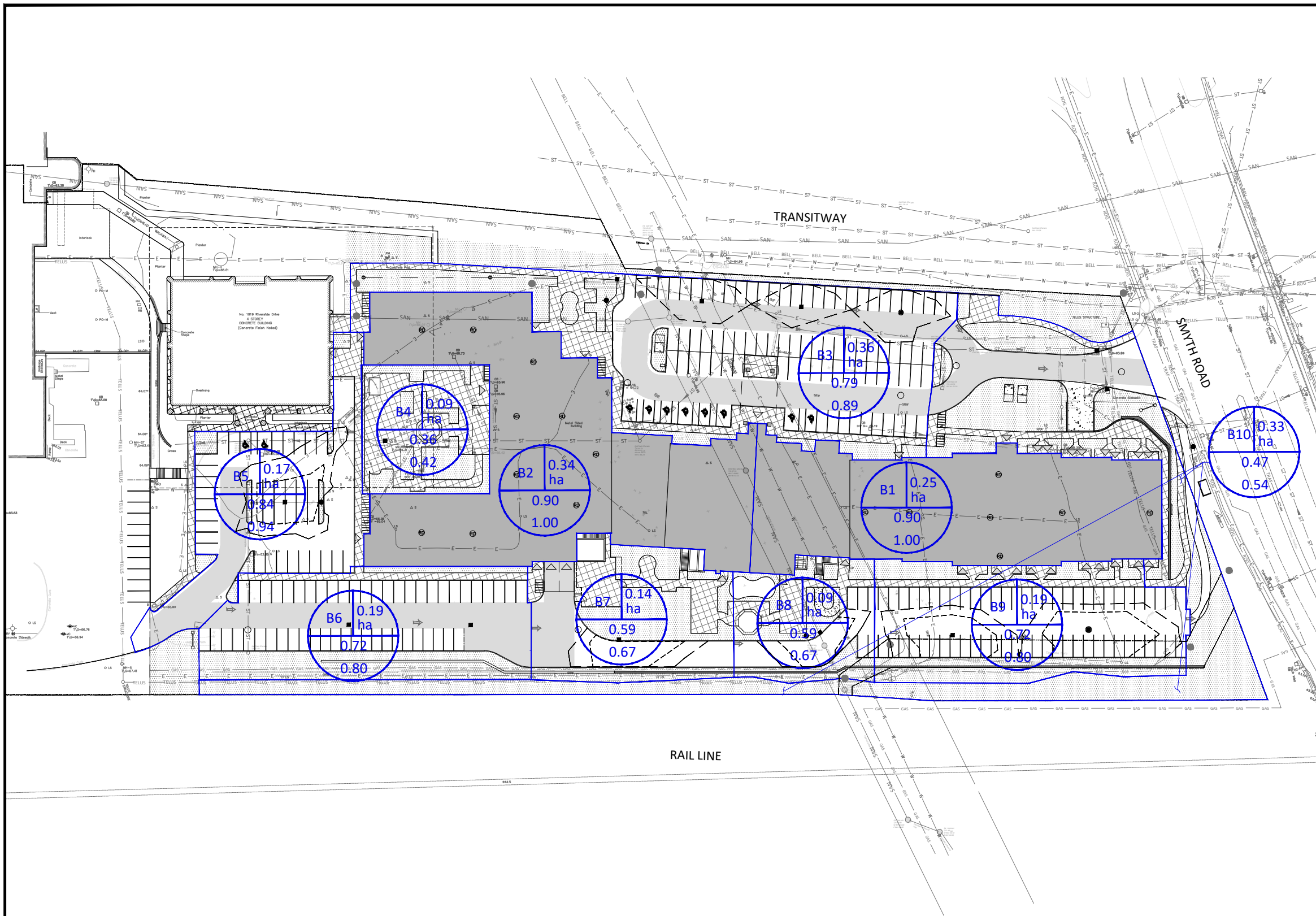

McINTOSH PERRY
 115 Walgreen Road, RR3, Carp, ON K0A 1L0
 Tel: 613-836-2184 Fax: 613-836-3742
 www.mcintoshperry.com

Drawn by:	Checked By:
R.R.R.	A.J.G.
Scale:	Project Number:
1:1000	CCO-21-2955

Client:	RBJ SCHLEGEL HOLDINGS 325 MAX BECKER DRIVE SUITE 201 KITCHENER, ON N2E 4H5	
Project:	LONG TERM CARE HOME 1919 RIVERSIDE DRIVE	
Drawing Title:	POST-DEVELOPMENT DRAINAGE AREA PLAN	
Drawings:	Revisions	Date
2	ISSUED FOR REVIEW	APR 8, 2022
1	ISSUED FOR REVIEW	NOV 2, 2021
Drawing Number:		POST

APPENDIX G
STORMWATER MANAGEMENT CALCULATIONS

McINTOSH PERRY

CCO-21-2955 - 1919 Riverside Drive - Runoff Calculations

1 of 13

Pre-Development Runoff Coefficient

Drainage Area	Area (ha)	Impervious Area (m ²)	C	Gravel Area (m ²)	C	Pervious Area (m ²)	C	C _{AVG} 5-Year	C _{AVG} 100-Year
A1	2.131	15,334.70	0.90	0.00	0.60	5,973.45	0.20	0.70	0.79

Pre-Development Runoff Calculations

Drainage Area	Area (ha)	C 5-Year	C 100-Year	Tc (min)	I (mm/hr)		Q (L/s)	
					5-Year	100-Year	5-Year	100-Year
A1	2.131	0.70	0.79	10	104.2	178.6	434.37	835.34
Total	2.131						434.37	835.34

Post-Development Runoff Coefficient

Drainage Area	Area (ha)	Impervious Area (m ²)	C	Gravel Area (m ²)	C	Pervious Area (m ²)	C	C _{AVG} 5-Year	C _{AVG} 100-Year
B1	0.246	2,459.13	0.90	0.00	0.60	0.00	0.20	0.90	1.00
B2	0.340	3,396.47	0.90	0.00	0.60	0.00	0.20	0.90	1.00
B3	0.355	3,012.92	0.90	0.00	0.60	539.90	0.20	0.79	0.89
B4	0.090	203.53	0.90	0.00	0.60	697.77	0.20	0.36	0.42
B5	0.168	1,540.19	0.90	0.00	0.60	135.20	0.20	0.84	0.94
B6	0.192	1,318.60	0.90	0.00	0.60	596.83	0.20	0.68	0.77
B7	0.141	793.39	0.90	0.00	0.60	614.48	0.20	0.59	0.67
B8	0.089	498.60	0.90	0.00	0.60	386.66	0.20	0.59	0.67
B9	0.189	1,397.89	0.90	0.00	0.60	493.52	0.20	0.72	0.80
B10	0.327	1,244.12	0.90	0.00	0.60	2,024.03	0.20	0.47	0.54

Post-Development Runoff Calculations

Drainage Area	Area (ha)	C 5-Year	C 100-Year	Tc (min)	I (mm/hr)		Q (L/s)	
					5-Year	100-Year	5-Year	100-Year
B1	0.246	0.90	1.00	10	104.2	178.6	64.11	122.07
B2	0.340	0.90	1.00	10	104.2	178.6	88.54	168.60
B3	0.355	0.79	0.89	10	104.2	178.6	81.67	156.26
B4	0.090	0.36	0.42	10	104.2	178.6	9.35	18.76
B5	0.168	0.84	0.94	10	104.2	178.6	40.93	78.13
B6	0.192	0.68	0.77	10	104.2	178.6	37.83	72.86
B7	0.141	0.59	0.67	10	104.2	178.6	24.24	47.01
B8	0.089	0.59	0.67	10	104.2	178.6	15.24	29.55
B9	0.189	0.72	0.80	10	104.2	178.6	39.30	75.51
B10	0.327	0.47	0.54	10	104.2	178.6	44.16	86.88
Total	2.135						445.38	855.63

McINTOSH PERRY

CCO-21-2955 - 1919 Riverside Drive - Runoff Calculations

2 of 13

Required Restricted Flow

Drainage Area	Area (ha)	C 5-Year	Tc (min)	I (mm/hr)	Q (L/s)
				5-Year	5-Year
A1	2.131	0.50	10	104.2	308.60

Post-Development Restricted Runoff Calculations

Drainage Area	Unrestricted Flow (L/s)		Restricted Flow (L/s)		Storage Required (m ³)		Storage Provided (m ³)		
	5-Year	100-Year	5-Year	100-Year	5-Year	100-Year	5-Year	100-Year	
B1	64.11	122.07	5.50	10.45	53.17	99.94	54.35	101.91	Restricted
B2	88.54	168.60	3.99	7.49	90.31	167.96	95.19	179.79	Restricted
B3	81.67	156.26	81.67	108.88	0.00	28.43		29.18	Restricted
B4	9.35	18.76	9.35	18.76					Unrestricted
B5	40.93	78.13	20.31	20.61	12.37	38.27	12.86	42.68	Restricted
B6	37.83	72.86	34.70	35.19	34.87	104.45	37.34	107.73	Restricted
B7	24.24	47.01							
B8	15.24	29.55							
B9	39.30	75.51	44.16	86.88					Unrestricted
B10	44.16	86.88							
Total	346.68	663.69	199.68	288.26	190.72	439.04	199.74	461.29	

McINTOSH PERRY

Storage Requirements for Area B1

5-Year Storm Event

Tc (min)	I (mm/hr)	B1 Runoff (L/s)	Allowable Outflow (L/s)	Runoff to be Stored (L/s)	Storage Required (m ³)
10	104.2	64.11	5.50	58.61	35.16
20	70.3	43.22	5.50	37.72	45.27
30	53.9	33.18	5.50	27.68	49.82
40	44.2	27.19	5.50	21.69	52.05
50	37.7	23.17	5.50	17.67	53.00
60	32.9	20.27	5.50	14.77	53.17
70	29.4	18.07	5.50	12.57	52.80
80	26.6	16.34	5.50	10.84	52.05
90	24.3	14.94	5.50	9.44	51.00
100	22.4	13.79	5.50	8.29	49.72

Maximum Storage Required 5-Year (m³) = 53.17

100-Year Storm Event

Tc (min)	I (mm/hr)	B1 Runoff (L/s)	Allowable Outflow (L/s)	Runoff to be Stored (L/s)	Storage Required (m ³)
10	178.6	122.07	10.45	111.62	66.97
20	120.0	82.00	10.45	71.55	85.86
30	91.9	62.80	10.45	52.35	94.24
40	75.1	51.37	10.45	40.92	98.21
50	64.0	43.72	10.45	33.27	99.81
60	55.9	38.21	10.45	27.76	99.94
70	49.8	34.04	10.45	23.59	99.07
80	45.0	30.76	10.45	20.31	97.48

Maximum Storage Required 100-Year (m³) = 99.94

Storage Occupied In Area B1

5-Year Storm Event

Roof Storage			
Location	Area*	Depth	Volume (m ³)
Roof	1358.78	0.040	54.35
Total			54.35

Storage Available (m³) = 54.35
Storage Required (m³) = 53.17

100-Year Storm Event

Roof Storage			
Location	Area*	Depth	Volume (m ³)
Roof	1358.78	0.075	101.91
Total			101.91

Storage Available (m³) = 101.91
Storage Required (m³) = 99.94

*Storage area is 75% of the total roof area. Peaked section of roof excluded as storage area.

McINTOSH PERRY

Roof Drain Flow (B1)

Roof Drains Summary		
Type of Control Device	Watts Drainage - Accutrol Weir	
Number of Roof Drains	11	
	5-Year	100-Year
Rooftop Storage (m ³)	54.35	101.91
Storage Depth (m)	0.040	0.075
Flow (Per Roof Drain) (L/s)	0.50	0.95
Total Flow (L/s)	5.50	10.45

Flow Rate Vs. Build-Up (One Weir)	
Depth (mm)	Flow (L/s)
15	0.19
20	0.25
25	0.32
30	0.38
35	0.44
40	0.50
45	0.57
50	0.63
55	0.69

*Roof Drain model to be Accutrol Weirs, See attached sheets

*Roof Drain Flow information taken from Watts Drainage website

CALCULATING ROOF FLOW EXAMPLES

2 roof drains during a 5 year storm
 elevation of water = 30mm
 Flow leaving 2 roof drains = (2 x 0.36 L/s) = 0.72 L/s

2 roof drains during a 100 year storm
 elevation of water = 45mm
 Flow leaving 2 roof drains = (2 x 0.54 L/s) = 1.08 L/s

Roof Drain Flow			
	Flow (l/s)	Storage Depth (mm)	Drains Flow (l/s)
	0.19	15	2.09
	0.25	20	2.75
	0.32	25	3.52
	0.38	30	4.18
	0.44	35	4.84
5-Year	0.50	40	5.50
	0.57	45	6.27
	0.63	50	6.93
	0.69	55	7.59
	0.76	60	8.36
	0.82	65	9.02
	0.88	70	9.68
100-Year	0.95	75	10.45
	1.01	80	11.11
	1.07	85	11.77
	1.13	90	12.43
	1.20	95	13.20
	1.26	100	13.86
	1.32	105	14.52
	1.39	110	15.29
	1.45	115	15.95
	1.51	120	16.61
	1.58	125	17.38
	1.64	130	18.04
	1.70	135	18.70
	1.76	140	19.36
	1.83	145	20.13
	1.89	150	20.79

Note: The flow leaving through a restricted roof drain is based on flow vs. head information

McINTOSH PERRY

Storage Requirements for Area B2

5-Year Storm Event

Tc (min)	I (mm/hr)	B2 Runoff (L/s)	Allowable Outflow (L/s)	Runoff to be Stored (L/s)	Storage Required (m ³)
10	104.2	88.54	3.99	84.55	50.73
20	70.3	59.70	3.99	55.71	66.85
30	53.9	45.83	3.99	41.84	75.31
40	44.2	37.55	3.99	33.56	80.54
50	37.7	32.00	3.99	28.01	84.02
60	32.9	28.00	3.99	24.01	86.42
70	29.4	24.96	3.99	20.97	88.07
80	26.6	22.57	3.99	18.58	89.20
90	24.3	20.64	3.99	16.65	89.91
100	22.4	19.04	3.99	15.05	90.31

Maximum Storage Required 5-Year (m ³) =	90.31
---	-------

100-Year Storm Event

Tc (min)	I (mm/hr)	B2 Runoff (L/s)	Allowable Outflow (L/s)	Runoff to be Stored (L/s)	Storage Required (m ³)
10	178.6	168.60	7.49	161.11	96.67
20	120.0	113.26	7.49	105.77	126.92
30	91.9	86.74	7.49	79.25	142.66
40	75.1	70.95	7.49	63.46	152.31
50	64.0	60.39	7.49	52.90	158.69
60	55.9	52.78	7.49	45.29	163.03
70	49.8	47.01	7.49	39.52	165.99
80	45.0	42.48	7.49	34.99	167.96

Maximum Storage Required 100-Year (m ³) =	167.96
---	--------

Storage Occupied In Area B2

5-Year Storm Event

Roof Storage			
Location	Area*	Depth	Volume (m ³)
Roof	2115.23	0.045	95.19
		Total	95.19

Storage Available (m ³) =	95.19
Storage Required (m ³) =	90.31

100-Year Storm Event

Roof Storage			
Location	Area*	Depth	Volume (m ³)
Roof	2115.23	0.085	179.79
		Total	179.79

Storage Available (m ³) =	179.79
Storage Required (m ³) =	167.96

*Storage area is 75% of the total roof area. Peaked section of roof excluded as storage area.

McINTOSH PERRY

Roof Drain Flow (B2)

Roof Drains Summary		
Type of Control Device	Watts Drainage - Accutrol Weir	
Number of Roof Drains	7	
	5-Year	100-Year
Rooftop Storage (m ³)	54.35	101.91
Storage Depth (m)	0.045	0.085
Flow (Per Roof Drain) (L/s)	0.57	1.07
Total Flow (L/s)	3.99	7.49

Flow Rate Vs. Build-Up (One Weir)	
Depth (mm)	Flow (L/s)
15	0.19
20	0.25
25	0.32
30	0.38
35	0.44
40	0.50
45	0.57
50	0.63
55	0.69

*Roof Drain model to be Accutrol Weirs, See attached sheets

*Roof Drain Flow information taken from Watts Drainage website

CALCULATING ROOF FLOW EXAMPLES

2 roof drains during a 5 year storm
 elevation of water = 30mm
 Flow leaving 2 roof drains = (2 x 0.36 L/s) = 0.72 L/s

2 roof drains during a 100 year storm
 elevation of water = 45mm
 Flow leaving 2 roof drains = (2 x 0.54 L/s) = 1.08 L/s

Roof Drain Flow			
	Flow (l/s)	Storage Depth (mm)	Drains Flow (l/s)
	0.19	15	1.33
	0.25	20	1.75
	0.32	25	2.24
	0.38	30	2.66
	0.44	35	3.08
	0.50	40	3.50
5-Year	0.57	45	3.99
	0.63	50	4.41
	0.69	55	4.83
	0.76	60	5.32
	0.82	65	5.74
	0.88	70	6.16
	0.95	75	6.65
	1.01	80	7.07
100-Year	1.07	85	7.49
	1.13	90	7.91
	1.20	95	8.40
	1.26	100	8.82
	1.32	105	9.24
	1.39	110	9.73
	1.45	115	10.15
	1.51	120	10.57
	1.58	125	11.06
	1.64	130	11.48
	1.70	135	11.90
	1.76	140	12.32
	1.83	145	12.81
	1.89	150	13.23

Note: The flow leaving through a restricted roof drain is based on flow vs. head information

McINTOSH PERRY

Storage Requirements for Area B3

5-Year Storm Event

Tc (min)	I (mm/hr)	B3 Runoff (L/s)	Allowable Outflow (L/s)	Runoff to be Stored (L/s)	Storage Required (m ³)
10	104.2	81.67	105.33	-23.66	0.00
15	83.6	65.50	105.33	-39.83	0.00
20	70.3	55.07	105.33	-50.26	0.00
25	60.9	47.73	105.33	-57.60	0.00
30	53.9	42.27	105.33	-63.06	0.00
35	48.5	38.03	105.33	-67.30	0.00
40	44.2	34.63	105.33	-70.70	0.00

Maximum Storage Required 5-Year (m³) = 0.00

100-Year Storm Event

Tc (min)	I (mm/hr)	B3 Runoff (L/s)	Allowable Outflow (L/s)	Runoff to be Stored (L/s)	Storage Required (m ³)
10	178.6	156.26	108.88	47.38	28.43
15	142.9	125.05	108.88	16.17	14.55
20	120.0	104.97	108.88	-3.91	0.00
25	103.8	90.88	108.88	-18.00	0.00
30	91.9	80.40	108.88	-28.48	0.00
35	82.6	72.27	108.88	-36.61	0.00
40	75.1	65.76	108.88	-43.12	0.00

Maximum Storage Required 100-Year (m³) = 28.43

100-Year Storm Event Storage Summary

Water Elev. (m) =		65.32			
Structure	T/G	Inv (m)	Head (m)	Depth (m)	Storage
CB1	65.15	62.45	2.64	0.17	11.64
CB2	65.15	62.72	2.37	0.17	8.05
CBMH3	65.15	62.85	2.24	0.17	9.49
Total					29.18

100 Year Storage Summary

Storage Available (m ³) =	29.2
Storage Required (m ³) =	28.4

McINTOSH PERRY

CCO-21-2955 - 1919 Riverside Drive - Runoff Calculations

8 of 13

For Orifice Flow, C= 0.6
 For Weir Flow, C= 3.33

	Orifice 1	Orifice 2	Weir 1	Weir 2
invert elevation	62.58			
center of crest elevation	62.67			
orifice width / weir length	179 mm			
orifice height				
orifice area (m ²)	0.025	0.000		

Elevation Discharge Table - Storm Routing

Elevation (m)	Orifice 1		Orifice 2		Weir 1		Weir 2		Total Q [l/s]
	H [m]	Q [m ³]	H [m]	Q [m ³]	H [m]	Q [m ³]	H [m]	Q [m ³]	
62.58	x	x							0.00
62.60	x	x							0.00
62.61	x	x							0.00
62.62	x	x							0.00
62.63	x	x							0.00
62.64	x	x							0.00
62.65	x	x							0.00
65.12	2.45	0.105							104.69
65.13	2.46	0.105							104.91
65.14	2.47	0.105							105.12
65.15	2.48	0.105							105.33
65.16	2.49	0.106							105.55
65.17	2.50	0.106							105.76
65.18	2.51	0.106							105.97
65.19	2.52	0.106							106.18
65.20	2.53	0.106							106.39
65.21	2.54	0.107							106.60
65.22	2.55	0.107							106.81
65.23	2.56	0.107							107.02
65.24	2.57	0.107							107.23
65.25	2.58	0.107							107.44
65.26	2.59	0.108							107.64
65.27	2.60	0.108							107.85
65.28	2.61	0.108							108.06
65.29	2.62	0.108							108.27
65.30	2.63	0.108							108.47
65.31	2.64	0.109							108.68
65.32	2.65	0.109							108.88

- Notes:
1. For Orifice Flow, User is to Input an Elevation Higher than Crown of Orifice.
 2. Orifice Equation: $Q = cA(2gh)^{1/2}$
 3. Weir flow calculated in Bentley's FlowMaster - Trapezoidal Channel at 0.1%, 3:1 side slopes, roughness coeff. Of 0.035
 4. These Computations Do Not Account for Submergence Effects Within the Pond Riser.
 5. H for orifice equations is depth of water above the centroide of the orifice.
 6. H for weir equations is depth of water above the weir crest.

McINTOSH PERRY

Storage Requirements for Area B5

5-Year Storm Event

Tc (min)	I (mm/hr)	B5 Runoff (L/s)	Allowable Outflow (L/s)	Runoff to be Stored (L/s)	Storage Required (m ³)
10	104.2	40.93	20.31	20.62	12.37
12	94.7	37.20	20.31	16.89	12.16
14	86.9	34.15	20.31	13.84	11.63
16	80.5	31.61	20.31	11.30	10.85
18	75.0	29.45	20.31	9.14	9.88
20	70.3	27.60	20.31	7.29	8.75
22	66.1	25.99	20.31	5.68	7.49

Maximum Storage Required 5-Year (m³) = 12.37

100-Year Storm Event

Tc (min)	I (mm/hr)	B5 Runoff (L/s)	Allowable Outflow (L/s)	Runoff to be Stored (L/s)	Storage Required (m ³)
10	178.6	78.13	20.61	57.52	34.51
12	162.1	70.94	20.61	50.33	36.24
14	148.7	65.08	20.61	44.47	37.35
16	137.5	60.19	20.61	39.58	37.99
18	128.1	56.05	20.61	35.44	38.27
20	120.0	52.49	20.61	31.88	38.25
22	112.9	49.39	20.61	28.78	37.99

Maximum Storage Required 100-Year (m³) = 38.27

5 Year Storage Summary

Water Elev. (m) =	65.67				
Structure	T/G	INV. (out)	Head (m)	Depth (m)	Storage Volume
CB11	65.50	62.60	2.92	3.07	12.86

Storage Available (m³) = 12.9
Storage Required (m³) = 12.4

100 Year Storage Summary

Water Elev. (m) =	65.76				
Structure	T/G	INV. (out)	Head (m)	Depth (m)	Storage Volume
CB11	65.50	62.60	3.01	3.16	42.68
Total					42.68

Storage Available (m³) = 42.7
Storage Required (m³) = 38.3

McINTOSH PERRY

CCO-21-2955 - 1919 Riverside Drive - Runoff Calculations

10 of 13

For Orifice Flow, C=	0.6	Orifice 1	Orifice 2	Weir 1	Weir 2
For Weir Flow, C=	3.33	invert elevation	62.64		
		center of crest elevation	62.68		
		orifice width / weir length	75 mm		
		orifice height			
		orifice area (m ²)	0.004	0.000	

Elevation Discharge Table - Storm Routing

Elevation (m)	Orifice 1		Orifice 2		Weir 1		Weir 2		Total Q (l/s)
	H (m)	Q (m ³)	H (m)	Q (m ³)	H (m)	Q (m ³)	H (m)	Q (m ³)	
62.64	x	x							0.00
62.66	x	x							0.00
62.67	x	x							0.00
62.68	0.00	0.001							0.59
62.69	0.01	0.001							1.31
62.70	0.02	0.002							1.76
62.71	0.03	0.002							2.12
62.72	0.04	0.002							2.42
62.73	0.05	0.003							2.69
62.74	0.06	0.003							2.94
62.75	0.07	0.003							3.16
62.76	0.08	0.003							3.37
62.77	0.09	0.004							3.57
62.78	0.10	0.004							3.76
62.79	0.11	0.004							3.94
62.80	0.12	0.004							4.11
62.81	0.13	0.004							4.27
62.82	0.14	0.004							4.43
62.83	0.15	0.005							4.59
62.84	0.16	0.005							4.73
62.85	0.17	0.005							4.88
62.86	0.18	0.005							5.02
62.87	0.19	0.005							5.15
62.88	0.20	0.005							5.28
62.89	0.21	0.005							5.41
62.90	0.22	0.006							5.54
62.91	0.23	0.006							5.66
65.35	2.67	0.019							19.19
65.36	2.68	0.019							19.23
65.37	2.69	0.019							19.27
65.38	2.70	0.019							19.30
65.39	2.71	0.019							19.34
65.40	2.72	0.019							19.37
65.41	2.73	0.019							19.41
65.42	2.74	0.019							19.44
65.43	2.75	0.019							19.48
65.44	2.76	0.020							19.51
65.45	2.77	0.020							19.55
65.46	2.78	0.020							19.59
65.47	2.79	0.020							19.62
65.48	2.80	0.020							19.66
65.49	2.81	0.020							19.69
65.50	2.82	0.020							19.73
65.51	2.83	0.020							19.76
65.52	2.84	0.020							19.80
65.53	2.85	0.020							19.83
65.54	2.86	0.020							19.86
65.55	2.87	0.020							19.90
65.56	2.88	0.020							19.93
65.57	2.89	0.020							19.97
65.58	2.90	0.020							20.00
65.59	2.91	0.020							20.04
65.60	2.92	0.020							20.07
65.61	2.93	0.020							20.11
65.62	2.94	0.020							20.14
65.63	2.95	0.020							20.17
65.64	2.96	0.020							20.21
65.65	2.97	0.020							20.24
65.66	2.98	0.020							20.28
65.67	2.99	0.020							20.31
65.68	3.00	0.020							20.34
65.69	3.01	0.020							20.38
65.70	3.02	0.020							20.41
65.71	3.03	0.020							20.45
65.72	3.04	0.020							20.48
65.73	3.05	0.021							20.51
65.74	3.06	0.021							20.55
65.75	3.07	0.021							20.58
65.76	3.08	0.021							20.61
65.77	3.09	0.021							20.65
65.78	3.10	0.021							20.68

- Notes: 1. For Orifice Flow, User is to Input an Elevation Higher than Crown of Orifice.
 2. Orifice Equation: $Q = cA(2gh)^{1/2}$
 3. Weir flow calculated in Bentley's FlowMaster - Trapezoidal Channel at 0.1%, 3:1 side slopes, roughness coeff. Of 0.035
 4. These Computations Do Not Account for Submergence Effects Within the Pond Riser.
 5. H for orifice equations is depth of water above the centroid of the orifice.
 6. H for weir equations is depth of water above the weir crest.

McINTOSH PERRY

CCO-21-2955 - 1919 Riverside Drive - Runoff Calculations

11 of 13

Storage Requirements for Area B6, B7, B8 & B9
5-Year Storm Event

Tc (min)	I (mm/hr)	B6 Runoff (L/s)	B7 Runoff (L/s)	B8 Runoff (L/s)	B9 Runoff (L/s)	Allowable Outflow (L/s)	Runoff to be Stored (L/s)	Storage Required (m ³)
10	104.2	37.83	24.24	15.24	14.27	34.70	56.88	34.13
15	83.6	30.34	19.44	12.22	11.44	34.70	38.74	34.87
20	70.3	25.51	16.35	10.27	9.62	34.70	27.05	32.46
25	60.9	22.11	14.17	8.91	8.34	34.70	18.83	28.24
30	53.9	19.58	12.55	7.89	7.39	34.70	12.70	22.86
35	48.5	17.62	11.29	7.10	6.64	34.70	7.95	16.69
40	44.2	16.04	10.28	6.46	6.05	34.70	4.14	9.93

Maximum Storage Required 5-Year (m³) = 34.87

100-Year Storm Event

Tc (min)	I (mm/hr)	B6 Runoff (L/s)	B7 Runoff (L/s)	B8 Runoff (L/s)	B9 Runoff (L/s)	Allowable Outflow (L/s)	Runoff to be Stored (L/s)	Storage Required (m ³)
10	178.6	72.86	47.01	29.55	30.81	35.19	145.04	87.03
15	142.9	58.31	37.62	23.65	24.66	35.19	109.04	98.14
20	120.0	48.95	31.58	19.85	20.70	35.19	85.88	103.06
25	103.8	42.37	27.34	17.19	17.92	35.19	69.63	104.45
30	91.9	37.49	24.19	15.20	15.85	35.19	57.54	103.57
35	82.6	33.70	21.74	13.67	14.25	35.19	48.16	101.14
40	75.1	30.66	19.78	12.44	12.97	35.19	40.66	97.58

Maximum Storage Required 100-Year (m³) = 104.45

5 Year Storage Summary

Water Elev. (m) =	65.57				
Structure	T/G	INV. (out)	Head (m)	Depth (m)	Storage Volume
CICB8	65.40	63.30	2.12	2.27	5.55
CICB9	65.40	63.56	1.86	2.01	6.37
CB10	65.40	64.43	0.99	1.14	9.63
CBMH4	65.40	64.43	0.99	1.14	15.79
Total					37.34

Storage Available (m³) = 37.3
Storage Required (m³) = 34.9

100 Year Storage Summary

Water Elev. (m) =	65.65				
Structure	T/G	INV. (out)	Head (m)	Depth (m)	Storage Volume
CICB8	65.40	63.30	2.20	2.35	17.94
CICB9	65.40	63.56	1.94	2.09	17.03
CB10	65.40	64.43	1.07	1.22	28.57
CB11	65.40	64.43	1.07	1.22	44.19
Total					107.73

Storage Available (m³) = 107.7
Storage Required (m³) = 104.4

McINTOSH PERRY

CCO-21-2955 - 1919 Riverside Drive - Runoff Calculations

12 of 13

For Orifice Flow, C= 0.6
 For Weir Flow, C= 3.33

	Orifice 1	Orifice 2	Weir 1	Weir 2
invert elevation	62.70			
center of crest elevation	62.75			
orifice width / weir length	100 mm			
orifice height				
orifice area (m ²)	0.008	0.000		

Elevation Discharge Table - Storm Routing

Elevation (m)	Orifice 1		Orifice 2		Weir 1		Weir 2		Total Q [l/s]
	H [m]	Q [m ³]	H [m]	Q [m ³]	H [m]	Q [m ³]	H [m]	Q [m ³]	
62.70	x	x							0.00
62.72	x	x							0.00
62.73	x	x							0.00
62.74	x	x							0.00
62.75	0.00	0.000							0.33
62.76	0.01	0.002							2.09
62.77	0.02	0.003							2.94
62.78	0.03	0.004							3.59
62.79	0.04	0.004							4.15
62.80	0.05	0.005							4.63
62.81	0.06	0.005							5.07
62.82	0.07	0.005							5.48
62.83	0.08	0.006							5.85
62.84	0.09	0.006							6.21
62.85	0.10	0.007							6.54
62.86	0.11	0.007							6.86
62.87	0.12	0.007							7.17
62.88	0.13	0.007							7.46
62.89	0.14	0.008							7.74
62.90	0.15	0.008							8.01
62.91	0.16	0.008							8.27
62.92	0.17	0.009							8.53
62.93	0.18	0.009							8.77
62.94	0.19	0.009							9.01
62.95	0.20	0.009							9.25
62.96	0.21	0.009							9.48
62.97	0.22	0.010							9.70
65.41	2.66	0.034							33.71
65.42	2.67	0.034							33.77
65.43	2.68	0.034							33.83
65.44	2.69	0.034							33.89
65.45	2.70	0.034							33.96
65.46	2.71	0.034							34.02
65.47	2.72	0.034							34.08
65.48	2.73	0.034							34.15
65.49	2.74	0.034							34.21
65.50	2.75	0.034							34.27
65.51	2.76	0.034							34.33
65.52	2.77	0.034							34.40
65.53	2.78	0.034							34.46
65.54	2.79	0.035							34.52
65.55	2.80	0.035							34.58
65.56	2.81	0.035							34.64
65.57	2.82	0.035							34.70
65.58	2.83	0.035							34.77
65.59	2.84	0.035							34.83
65.60	2.85	0.035							34.89
65.61	2.86	0.035							34.95
65.62	2.87	0.035							35.01
65.63	2.88	0.035							35.07
65.64	2.89	0.035							35.13
65.65	2.90	0.035							35.19
65.66	2.91	0.035							35.25
65.67	2.92	0.035							35.31

McINTOSH PERRY

CCO-21-2955 - 1919 Riverside Drive - Runoff Calculations

13 of 13

Time of Concentration Pre-Development

Drainage Area ID	Sheet Flow Distance (m)	Slope of Land (%)	Tc (min) (5-Year)	Tc (min) (100-Year)
A1	102	2.29	10	5

*Therefore, a Tc of 10 can be used

$$T_c = (3.26(1.1-c)L^{0.5}/S^{0.33})$$

c= Balanced Runoff Coefficient

L= Length of Drainage Area

S= Average Slope of Watershed

Hydro First Defense® - HC



Rev. 11.1

Project Name: **CCO-21-2955** Report Date: **2022-04-08** Paste
 Street: **1919 RIVERSIDE** City: **OTTAWA**
 Province: **ONTARIO** Country: **CANADA**
 Designer: **RYAN ROBINEAU** email: **r.robineau@mcintoshperry.com**

Net Annual Removal Model: FD-3HC

Intensity ⁽¹⁾	Fraction of Rainfall ⁽¹⁾	FD-3HC Removal Efficiency ⁽²⁾	Weighted Net Annual Efficiency
(mm/hr)	(%)	(%)	(%)
0.50	0.1%	97.4%	0.1%
1.00	14.1%	91.3%	12.9%
1.50	14.2%	87.9%	12.5%
2.00	14.1%	85.6%	12.1%
2.50	4.2%	83.9%	3.5%
3.00	1.5%	82.4%	1.2%
3.50	8.5%	81.3%	6.9%
4.00	5.4%	80.3%	4.4%
4.50	1.2%	79.4%	0.9%
5.00	5.5%	78.6%	4.3%
6.00	4.3%	77.3%	3.3%
7.00	4.5%	76.2%	3.4%
8.00	3.1%	75.3%	2.3%
9.00	2.3%	74.4%	1.7%
10.00	2.6%	73.7%	1.9%
20.00	9.2%	69.1%	6.4%
30.00	2.6%	66.6%	1.7%
40.00	1.2%	64.8%	0.8%
50.00	0.5%	63.5%	0.3%
100.00	0.7%	59.5%	0.4%
150.00	0.1%	57.3%	0.0%
200.00	0.0%	55.8%	0.0%

Treatment Parameters:

Structure ID: **OGS1**
 TSS Goal: **80 % Removal**
 TSS Particle Size: **Fine**
 Area: **0.941 ha**
 Percent Impervious: **95%**
 Rational C value: **0.87** Calc. Cn
 Rainfall Station: **Ottawa, ONT** MAP
 Peak Storm Flow: **91.2 L/s**

RESULTS SUMMARY

Model	TSS	Volume
FD-3HC	81.0%	96.9%
FD-4HC	86.0%	99.5%
FD-5HC	90.0%	99.8%
FD-6HC	92.0%	100.0%
FD-8HC	95.0%	99.9%
FD-10HC	97.0%	99.9%

Model Specification:

Model: **FD-3HC**
 Diameter: **900 mm**
 Peak Flow Capacity: **425.00 L/s**
 Sediment Storage: **0.31 m³**
 Oil Storage: **473.00 L**

Installation Configuration:

Placement: **Offline**
 Outlet Pipe Size: **450 mm** OK
 Inlet Pipe 1 Size: **450 mm** OK
 Inlet Pipe 2 Size: **mm** OK
 Inlet Pipe 3 Size: **mm** OK
 Rim Level: **69.530 m** Calc Invs.
 Outlet Pipe Invert: **59.060 m** OK
 Invert Pipe 1: **59.120 m** OK
 Invert Pipe 2: **- m**
 Invert Pipe 3: **- m**

Total Net Annual Removal Efficiency: 81.0%

Total Annual Runoff Volume Treated: 96.9%

- Rainfall Data: 1960:2007, HLY03, Ottawa, ONT, 6105976 & 6105978.
- Based on third party verified data and approximating the removal of a PSD similar to the STC Fine distribution
- Rainfall adjusted to 5 min peak intensity based on hourly average.

Designer Notes:

Hydro First Defense® - HC

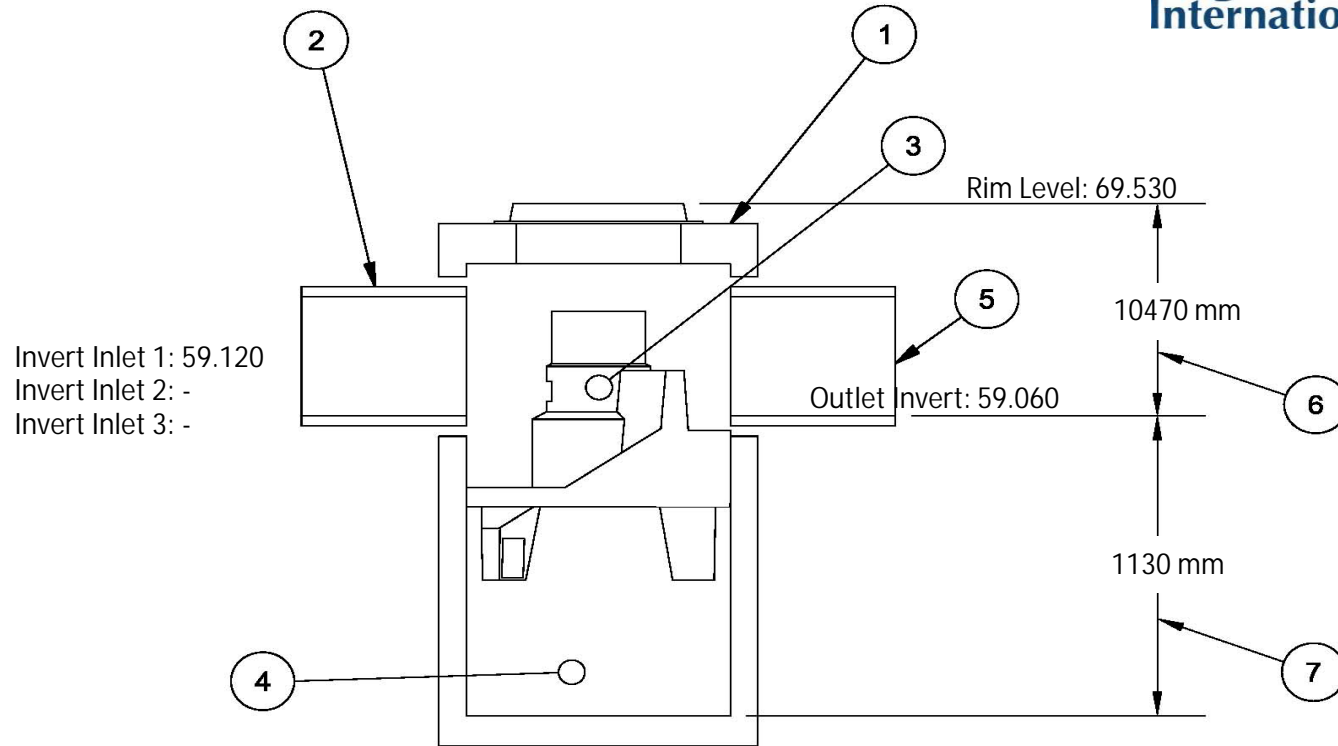

All drawing elevations are metres.

FD-3HC Specification

1	Vortex Chamber Diameter	900 mm
2	Inlet Pipe Diameter	450 mm
3	Oil Storage Capacity	473.00 L
4	Min. Provided Sediment Storage Capacity	0.31 m ³
5	Outlet Pipe Diameter	450 mm
6	Height(Final Grade to Outlet Invert)	10470 mm
7	Sump Depth(Outlet Invert to Sump)	1800 mm
	Total Depth	12270 mm

Notes:

Hydro First Defense® - HC



Rev. 11.1

Project Name: **CCO-21-2955** Report Date: **2022-04-08** Paste
 Street: **1919 RIVERSIDE** City: **OTTAWA**
 Province: **ONTARIO** Country: **CANADA**
 Designer: **RYAN ROBINEAU** email: **r.robineau@mcintoshperry.com**

Net Annual Removal Model: FD-3HC

Intensity ⁽¹⁾	Fraction of Rainfall ⁽¹⁾	FD-3HC Removal Efficiency ⁽²⁾	Weighted Net Annual Efficiency
(mm/hr)	(%)	(%)	(%)
0.50	0.1%	100.0%	0.1%
1.00	14.1%	97.1%	13.7%
1.50	14.2%	93.5%	13.3%
2.00	14.1%	91.0%	12.8%
2.50	4.2%	89.1%	3.7%
3.00	1.5%	87.6%	1.3%
3.50	8.5%	86.4%	7.4%
4.00	5.4%	85.3%	4.6%
4.50	1.2%	84.4%	1.0%
5.00	5.5%	83.6%	4.6%
6.00	4.3%	82.2%	3.6%
7.00	4.5%	81.0%	3.7%
8.00	3.1%	80.0%	2.5%
9.00	2.3%	79.1%	1.8%
10.00	2.6%	78.4%	2.0%
20.00	9.2%	73.5%	6.8%
30.00	2.6%	70.7%	1.9%
40.00	1.2%	68.9%	0.8%
50.00	0.5%	67.5%	0.4%
100.00	0.7%	63.3%	0.5%
150.00	0.1%	60.9%	0.0%
200.00	0.0%	59.3%	0.0%

Treatment Parameters:

Structure ID: **OGS2**
 TSS Goal: **80 % Removal**
 TSS Particle Size: **Fine**
 Area: **0.61 ha**
 Percent Impervious: **66%**
 Rational C value: **0.70** Calc. Cn
 Rainfall Station: **Ottawa, ONT** MAP
 Peak Storm Flow: **35.19 L/s**

RESULTS SUMMARY

Model	TSS	Volume
FD-3HC	86.0%	99.2%
FD-4HC	91.0%	99.9%
FD-5HC	94.0%	99.9%
FD-6HC	95.0%	99.9%
FD-8HC	97.0%	99.9%
FD-10HC	98.0%	99.9%

Model Specification:

Model: **FD-3HC**
 Diameter: **900 mm**
 Peak Flow Capacity: **425.00 L/s**
 Sediment Storage: **0.31 m³**
 Oil Storage: **473.00 L**

Installation Configuration:

Placement: **Online**
 Outlet Pipe Size: **375 mm** OK
 Inlet Pipe 1 Size: **375 mm** OK
 Inlet Pipe 2 Size: **mm** OK
 Inlet Pipe 3 Size: **mm** OK
 Rim Level: **69.530 m** Calc Invs.
 Outlet Pipe Invert: **62.680 m** OK
 Invert Pipe 1: **62.700 m** OK
 Invert Pipe 2: **- m**
 Invert Pipe 3: **- m**

Total Net Annual Removal Efficiency: 86.0%

Total Annual Runoff Volume Treated: 99.2%

- Rainfall Data: 1960:2007, HLY03, Ottawa, ONT, 6105976 & 6105978.
- Based on third party verified data and approximating the removal of a PSD similar to the STC Fine distribution
- Rainfall adjusted to 5 min peak intensity based on hourly average.

Designer Notes:

Hydro First Defense® - HC

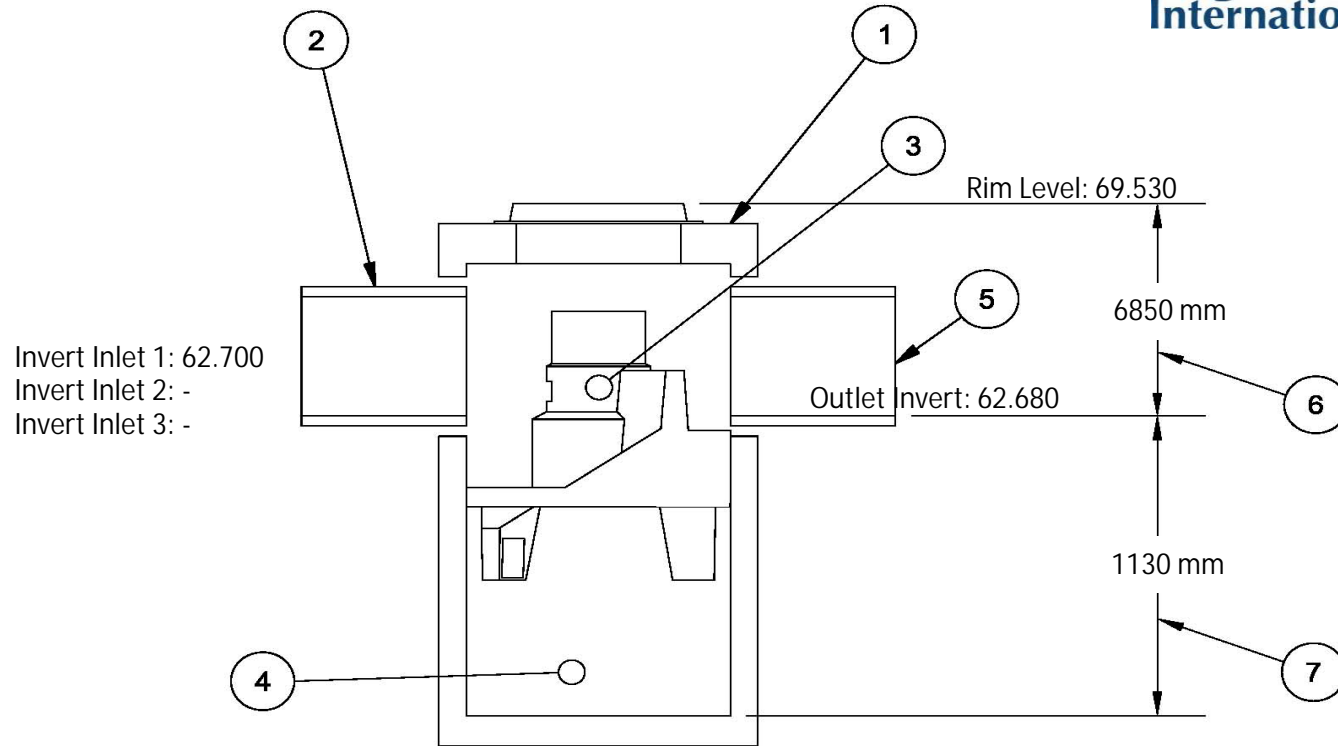

All drawing elevations are metres.

FD-3HC Specification

1	Vortex Chamber Diameter	900 mm
2	Inlet Pipe Diameter	375 mm
3	Oil Storage Capacity	473.00 L
4	Min. Provided Sediment Storage Capacity	0.31 m ³
5	Outlet Pipe Diameter	375 mm
6	Height(Final Grade to Outlet Invert)	6850 mm
7	Sump Depth(Outlet Invert to Sump)	1800 mm
	Total Depth	8650 mm

Notes:



Adjustable Accutrol Weir

Tag: _____

Adjustable Flow Control for Roof Drains

ADJUSTABLE ACCUTROL (for Large Sump Roof Drains only)

For more flexibility in controlling flow with heads deeper than 2", Watts Drainage offers the Adjustable Accutrol. The Adjustable Accutrol Weir is designed with a single parabolic opening that can be covered to restrict flow above 2" of head to less than 5 gpm per inch, up to 6" of head. To adjust the flow rate for depths over 2" of head, set the slot in the adjustable upper cone according to the flow rate required. Refer to Table 1 below.
 Note: Flow rates are directly proportional to the amount of weir opening that is exposed.

EXAMPLE:

For example, if the adjustable upper cone is set to cover 1/2 of the weir opening, flow rates above 2" of head will be restricted to 2-1/2 gpm per inch of head.

Therefore, at 3" of head, the flow rate through the Accutrol Weir that has 1/2 the slot exposed will be:
 [5 gpm (per inch of head) x 2 inches of head] + 2-1/2 gpm (for the third inch of head) = 12-1/2 gpm.

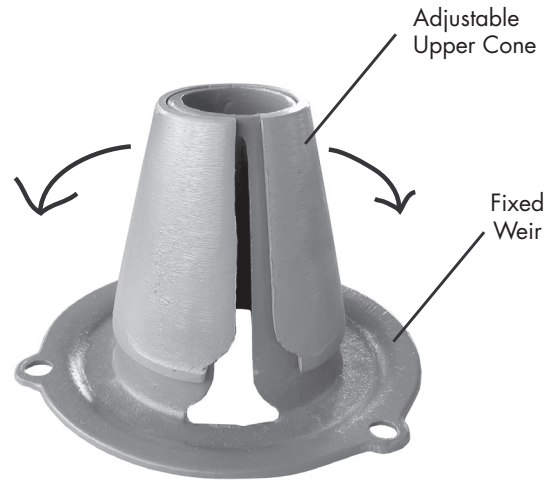
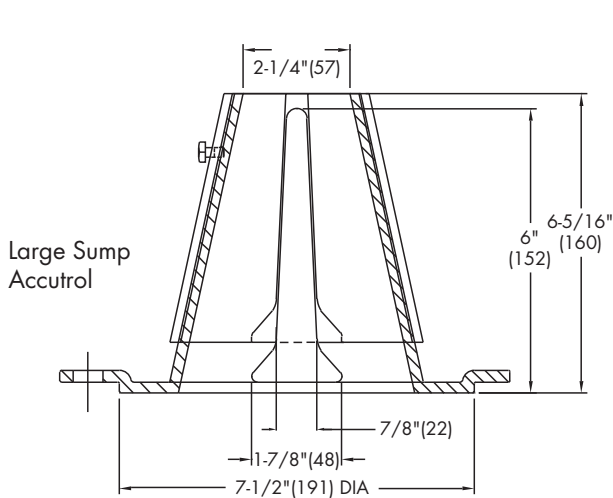

1/2 Weir Opening Exposed Shown Above

TABLE 1. Adjustable Accutrol Flow Rate Settings

Weir Opening Exposed	1"	2"	3"	4"	5"	6"
	Flow Rate (gallons per minute)					
Fully Exposed	5	10	15	20	25	30
3/4	5	10	13.75	17.5	21.25	25
1/2	5	10	12.5	15	17.5	20
1/4	5	10	11.25	12.5	13.75	15
Closed	5	5	5	5	5	5

Job Name _____
 Job Location _____
 Engineer _____

Contractor _____
 Contractor's P.O. No. _____
 Representative _____

Watts product specifications in U.S. customary units and metric are approximate and are provided for reference only. For precise measurements, please contact Watts Technical Service. Watts reserves the right to change or modify product design, construction, specifications, or materials without prior notice and without incurring any obligation to make such changes and modifications on Watts products previously or subsequently sold.

USA: Tel: (800) 338-2581 • Fax: (828) 248-3929 • Watts.com
 Canada: Tel: (905) 332-4090 • Fax: (905) 332-7068 • Watts.ca
 Latin America: Tel: (52) 81-1001-8600 • Fax: (52) 81-8000-7091 • Watts.com



**APPENDIX H
CITY OF OTTAWA DESIGN CHECKLIST**

City of Ottawa

4. Development Servicing Study Checklist

The following section describes the checklist of the required content of servicing studies. It is expected that the proponent will address each one of the following items for the study to be deemed complete and ready for review by City of Ottawa Infrastructure Approvals staff.

The level of required detail in the Servicing Study will increase depending on the type of application. For example, for Official Plan amendments and re-zoning applications, the main issues will be to determine the capacity requirements for the proposed change in land use and confirm this against the existing capacity constraint, and to define the solutions, phasing of works and the financing of works to address the capacity constraint. For subdivisions and site plans, the above will be required with additional detailed information supporting the servicing within the development boundary.

4.1 General Content

Criteria	Location (if applicable)
<input type="checkbox"/> Executive Summary (for larger reports only).	N/A
<input type="checkbox"/> Date and revision number of the report.	On Cover
<input type="checkbox"/> Location map and plan showing municipal address, boundary, and layout of proposed development.	Appendix A
<input type="checkbox"/> Plan showing the site and location of all existing services.	Site Servicing Plan (C102)
<input type="checkbox"/> Development statistics, land use, density, adherence to zoning and official plan, and reference to applicable subwatershed and watershed plans that provide context to which individual developments must adhere.	1.1 Purpose 1.2 Site Description 6.0 Stormwater Management
<input type="checkbox"/> Summary of pre-consultation meetings with City and other approval agencies.	Appendix B
<input type="checkbox"/> Reference and confirm conformance to higher level studies and reports (Master Servicing Studies, Environmental Assessments, Community Design Plans), or in the case where it is not in conformance, the proponent must provide justification and develop a defensible design criteria.	1.1 Purpose 1.2 Site Description 6.0 Stormwater Management
<input type="checkbox"/> Statement of objectives and servicing criteria.	3.0 Pre-Consultation Summary

<input type="checkbox"/> Identification of existing and proposed infrastructure available in the immediate area.	N/A
<input type="checkbox"/> Identification of Environmentally Significant Areas, watercourses and Municipal Drains potentially impacted by the proposed development (Reference can be made to the Natural Heritage Studies, if available).	Site Grading Plan (C101)
<input type="checkbox"/> Concept level master grading plan to confirm existing and proposed grades in the development. This is required to confirm the feasibility of proposed stormwater management and drainage, soil removal and fill constraints, and potential impacts to neighbouring properties. This is also required to confirm that the proposed grading will not impede existing major system flow paths.	Site Grading Plan (C101)
<input type="checkbox"/> Identification of potential impacts of proposed piped services on private services (such as wells and septic fields on adjacent lands) and mitigation required to address potential impacts.	N/A
<input type="checkbox"/> Proposed phasing of the development, if applicable.	N/A
<input type="checkbox"/> Reference to geotechnical studies and recommendations concerning servicing.	Section 2.0 Background Studies, Standards and References
<input type="checkbox"/> All preliminary and formal site plan submissions should have the following information: <ul style="list-style-type: none"> ○ Metric scale ○ North arrow (including construction North) ○ Key plan ○ Name and contact information of applicant and property owner ○ Property limits including bearings and dimensions ○ Existing and proposed structures and parking areas ○ Easements, road widening and rights-of-way ○ Adjacent street names 	Site Grading Plan (C101)

4.2 Development Servicing Report: Water

Criteria	Location (if applicable)
<input type="checkbox"/> Confirm consistency with Master Servicing Study, if available	N/A
<input type="checkbox"/> Availability of public infrastructure to service proposed development	N/A
<input type="checkbox"/> Identification of system constraints	N/A
<input type="checkbox"/> Identify boundary conditions	Appendix C
<input type="checkbox"/> Confirmation of adequate domestic supply and pressure	N/A
<input type="checkbox"/> Confirmation of adequate fire flow protection and confirmation that fire flow is calculated as per the Fire Underwriter's Survey. Output should show available fire flow at locations throughout the development.	Appendix C
<input type="checkbox"/> Provide a check of high pressures. If pressure is found to be high, an assessment is required to confirm the application of pressure reducing valves.	N/A
<input type="checkbox"/> Definition of phasing constraints. Hydraulic modeling is required to confirm servicing for all defined phases of the project including the ultimate design	N/A
<input type="checkbox"/> Address reliability requirements such as appropriate location of shut-off valves	N/A
<input type="checkbox"/> Check on the necessity of a pressure zone boundary modification.	N/A
<input type="checkbox"/> Reference to water supply analysis to show that major infrastructure is capable of delivering sufficient water for the proposed land use. This includes data that shows that the expected demands under average day, peak hour and fire flow conditions provide water within the required pressure range	Appendix C, Section 4.2

<input type="checkbox"/> Description of the proposed water distribution network, including locations of proposed connections to the existing system, provisions for necessary looping, and appurtenances (valves, pressure reducing valves, valve chambers, and fire hydrants) including special metering provisions.	Site Servicing Plan (C101)
<input type="checkbox"/> Description of off-site required feeder mains, booster pumping stations, and other water infrastructure that will be ultimately required to service proposed development, including financing, interim facilities, and timing of implementation.	N/A
<input type="checkbox"/> Confirmation that water demands are calculated based on the City of Ottawa Design Guidelines.	Appendix C
<input type="checkbox"/> Provision of a model schematic showing the boundary conditions locations, streets, parcels, and building locations for reference.	N/A

4.3 Development Servicing Report: Wastewater

Criteria	Location (if applicable)
<input type="checkbox"/> Summary of proposed design criteria (Note: Wet-weather flow criteria should not deviate from the City of Ottawa Sewer Design Guidelines. Monitored flow data from relatively new infrastructure cannot be used to justify capacity requirements for proposed infrastructure).	N/A
<input type="checkbox"/> Confirm consistency with Master Servicing Study and/or justifications for deviations.	N/A
<input type="checkbox"/> Consideration of local conditions that may contribute to extraneous flows that are higher than the recommended flows in the guidelines. This includes groundwater and soil conditions, and age and condition of sewers.	N/A
<input type="checkbox"/> Description of existing sanitary sewer available for discharge of wastewater from proposed development.	Section 5.2 Proposed Sanitary Sewer

<input type="checkbox"/> Verify available capacity in downstream sanitary sewer and/or identification of upgrades necessary to service the proposed development. (Reference can be made to previously completed Master Servicing Study if applicable)	Section 5.3 Proposed Sanitary Design
<input type="checkbox"/> Calculations related to dry-weather and wet-weather flow rates from the development in standard MOE sanitary sewer design table (Appendix 'C') format.	N/A
<input type="checkbox"/> Description of proposed sewer network including sewers, pumping stations, and forcemains.	Section 5.2 Proposed Sanitary Sewer
<input type="checkbox"/> Discussion of previously identified environmental constraints and impact on servicing (environmental constraints are related to limitations imposed on the development in order to preserve the physical condition of watercourses, vegetation, soil cover, as well as protecting against water quantity and quality).	N/A
<input type="checkbox"/> Pumping stations: impacts of proposed development on existing pumping stations or requirements for new pumping station to service development.	N/A
<input type="checkbox"/> Forcemain capacity in terms of operational redundancy, surge pressure and maximum flow velocity.	N/A
<input type="checkbox"/> Identification and implementation of the emergency overflow from sanitary pumping stations in relation to the hydraulic grade line to protect against basement flooding.	N/A
<input type="checkbox"/> Special considerations such as contamination, corrosive environment etc.	N/A

4.4 Development Servicing Report: Stormwater Checklist

Criteria	Location (if applicable)
<input type="checkbox"/> Description of drainage outlets and downstream constraints including legality of outlets (i.e. municipal drain, right-of-way, watercourse, or private property)	Section 6.0 Stormwater Sewer Design & Section 7.0 Proposed Stormwater Management
<input type="checkbox"/> Analysis of available capacity in existing public infrastructure.	N/A
<input type="checkbox"/> A drawing showing the subject lands, its surroundings, the receiving watercourse, existing drainage patterns, and proposed drainage pattern.	Pre & Post-Development Plans
<input type="checkbox"/> Water quantity control objective (e.g. controlling post-development peak flows to pre-development level for storm events ranging from the 2 or 5-year event (dependent on the receiving sewer design) to 100-year return period); if other objectives are being applied, a rationale must be included with reference to hydrologic analyses of the potentially affected subwatersheds, taking into account long-term cumulative effects.	Section 6.0 Stormwater Sewer Design & Section 7.0 Proposed Stormwater Management
<input type="checkbox"/> Water Quality control objective (basic, normal or enhanced level of protection based on the sensitivities of the receiving watercourse) and storage requirements.	Section 6.0 Stormwater Sewer Design & Section 7.0 Proposed Stormwater Management
<input type="checkbox"/> Description of the stormwater management concept with facility locations and descriptions with references and supporting information.	Section 6.0 Stormwater Sewer Design & Section 7.0 Proposed Stormwater Management
<input type="checkbox"/> Set-back from private sewage disposal systems.	N/A
<input type="checkbox"/> Watercourse and hazard lands setbacks.	N/A
<input type="checkbox"/> Record of pre-consultation with the Ontario Ministry of Environment and the Conservation Authority that has jurisdiction on the affected watershed.	N/A
<input type="checkbox"/> Confirm consistency with sub-watershed and Master Servicing Study, if applicable study exists.	N/A
<input type="checkbox"/> Storage requirements (complete with calculations) and conveyance capacity for minor events (1:5-year return period) and major events (1:100-year return period).	Appendix G

<input type="checkbox"/> Identification of watercourses within the proposed development and how watercourses will be protected, or, if necessary, altered by the proposed development with applicable approvals.	Site Grading Plan
<input type="checkbox"/> Calculate pre-and post development peak flow rates including a description of existing site conditions and proposed impervious areas and drainage catchments in comparison to existing conditions.	Section 7.0 Proposed Stormwater Management Appendix G
<input type="checkbox"/> Any proposed diversion of drainage catchment areas from one outlet to another.	Section 6.0 Stormwater Sewer Design & Section 7.0 Proposed Stormwater Management
<input type="checkbox"/> Proposed minor and major systems including locations and sizes of stormwater trunk sewers, and stormwater management facilities.	Section 6.0 Stormwater Sewer Design & Section 7.0 Proposed Stormwater Management
<input type="checkbox"/> If quantity control is not proposed, demonstration that downstream system has adequate capacity for the post-development flows up to and including the 100-year return period storm event.	N/A
<input type="checkbox"/> Identification of potential impacts to receiving watercourses	N/A
<input type="checkbox"/> Identification of municipal drains and related approval requirements.	N/A
<input type="checkbox"/> Descriptions of how the conveyance and storage capacity will be achieved for the development.	Section 6.0 Stormwater Sewer Design & Section 7.0 Proposed Stormwater Management
<input type="checkbox"/> 100-year flood levels and major flow routing to protect proposed development from flooding for establishing minimum building elevations (MBE) and overall grading.	Site Grading Plan (C101)
<input type="checkbox"/> Inclusion of hydraulic analysis including hydraulic grade line elevations.	N/A

<input type="checkbox"/> Description of approach to erosion and sediment control during construction for the protection of receiving watercourse or drainage corridors.	Section 8.0 Sediment & Erosion Control, Erosion and Sediment Control Plan C103
<input type="checkbox"/> Identification of floodplains – proponent to obtain relevant floodplain information from the appropriate Conservation Authority. The proponent may be required to delineate floodplain elevations to the satisfaction of the Conservation Authority if such information is not available or if information does not match current conditions.	N/A
<input type="checkbox"/> Identification of fill constraints related to floodplain and geotechnical investigation.	N/A

4.5 Approval and Permit Requirements: Checklist

The Servicing Study shall provide a list of applicable permits and regulatory approvals necessary for the proposed development as well as the relevant issues affecting each approval. The approval and permitting shall include but not be limited to the following:

Criteria	Location (if applicable)
<input type="checkbox"/> Conservation Authority as the designated approval agency for modification of floodplain, potential impact on fish habitat, proposed works in or adjacent to a watercourse, cut/fill permits and Approval under Lakes and Rivers Improvement Act. The Conservation Authority is not the approval authority for the Lakes and Rivers Improvement Act. Where there are Conservation Authority regulations in place, approval under the Lakes and Rivers Improvement Act is not required, except in cases of dams as defined in the Act.	N/A
<input type="checkbox"/> Application for Certificate of Approval (CofA) under the Ontario Water Resources Act.	N/A
<input type="checkbox"/> Changes to Municipal Drains.	N/A
<input type="checkbox"/> Other permits (National Capital Commission, Parks Canada, Public Works and Government Services Canada, Ministry of Transportation etc.)	N/A

4.6 Conclusion Checklist

Criteria	Location (if applicable)
<input type="checkbox"/> Clearly stated conclusions and recommendations	Section 9.0 Summary Section 10.0 Recommendations
<input type="checkbox"/> Comments received from review agencies including the City of Ottawa and information on how the comments were addressed. Final sign-off from the responsible reviewing agency.	All are stamped
<input type="checkbox"/> All draft and final reports shall be signed and stamped by a professional Engineer registered in Ontario	All are stamped