

TB6 & TB8 BOX-WALER DETAILS

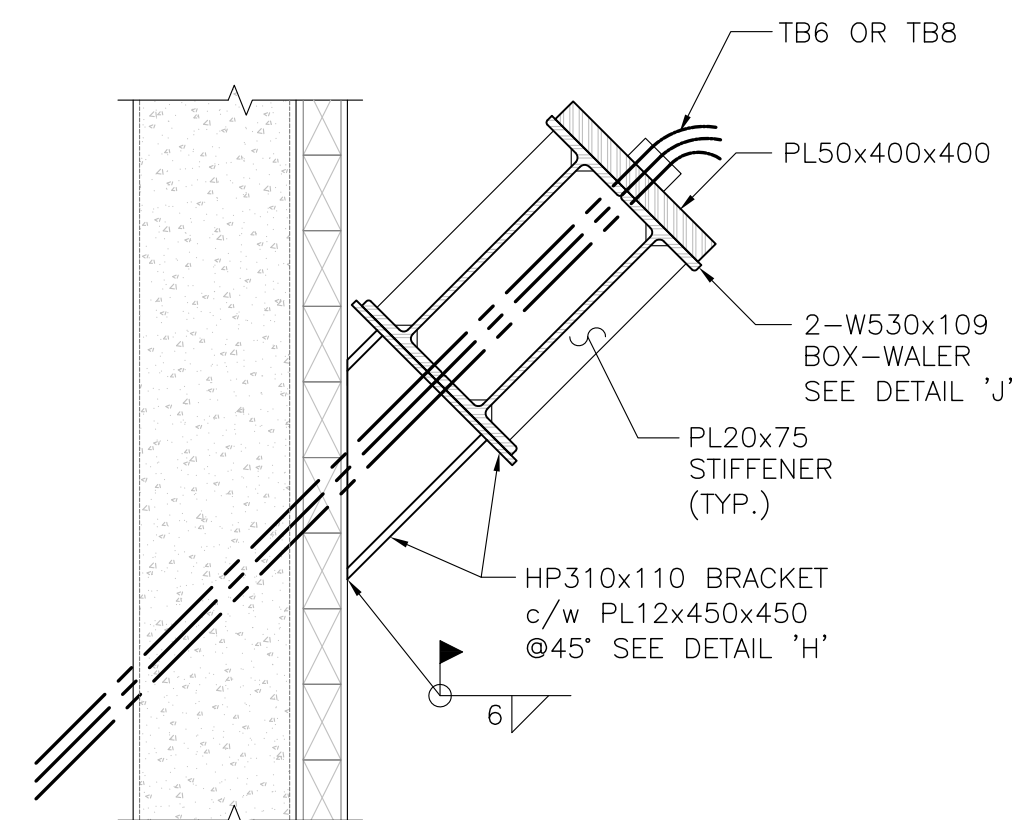

E
1:15

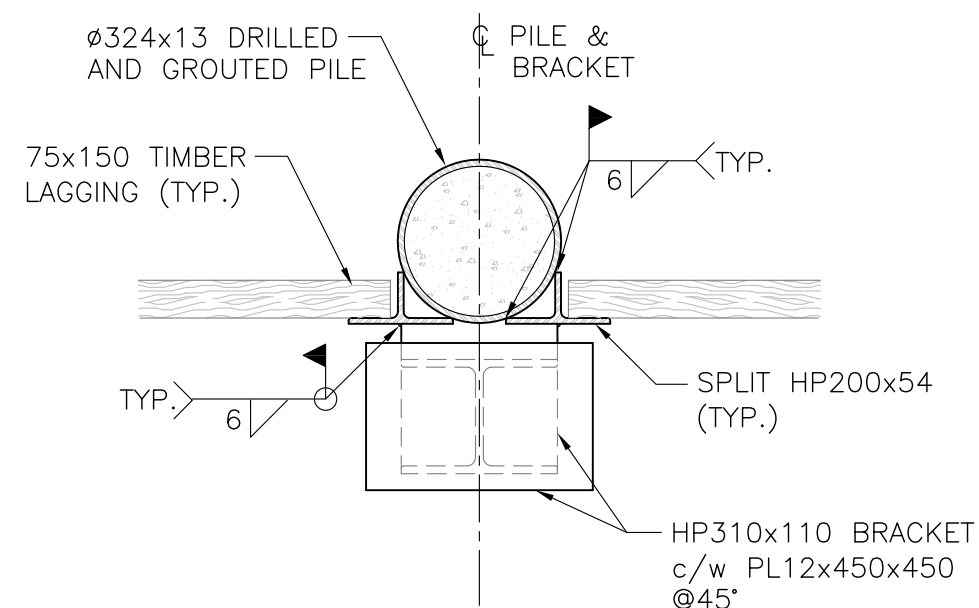

H
1:15

TB10 & TB12 BOX-WALER DETAILS

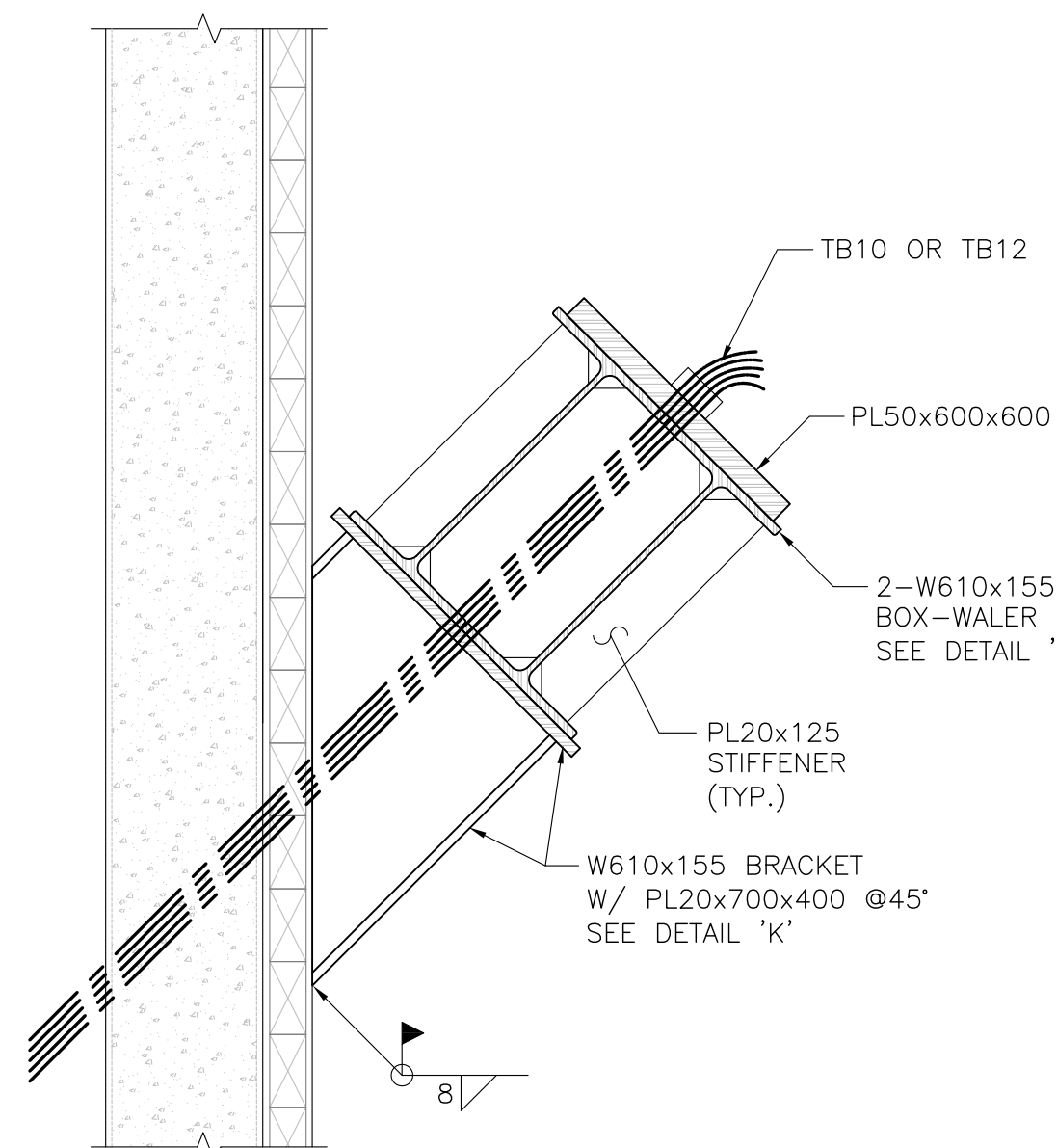

F
1:15

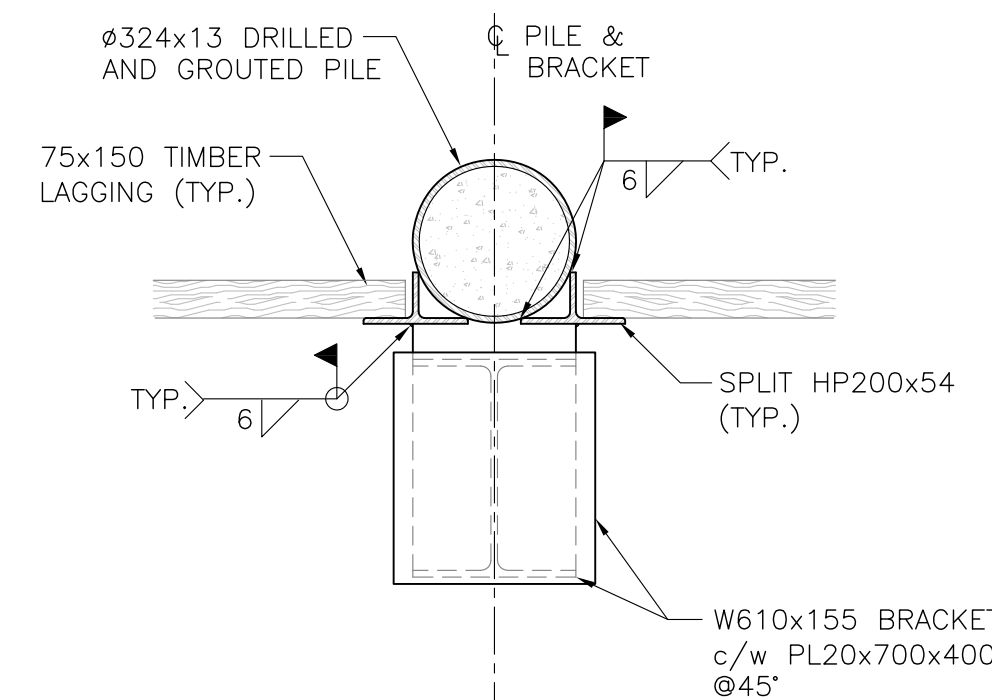

K
1:15

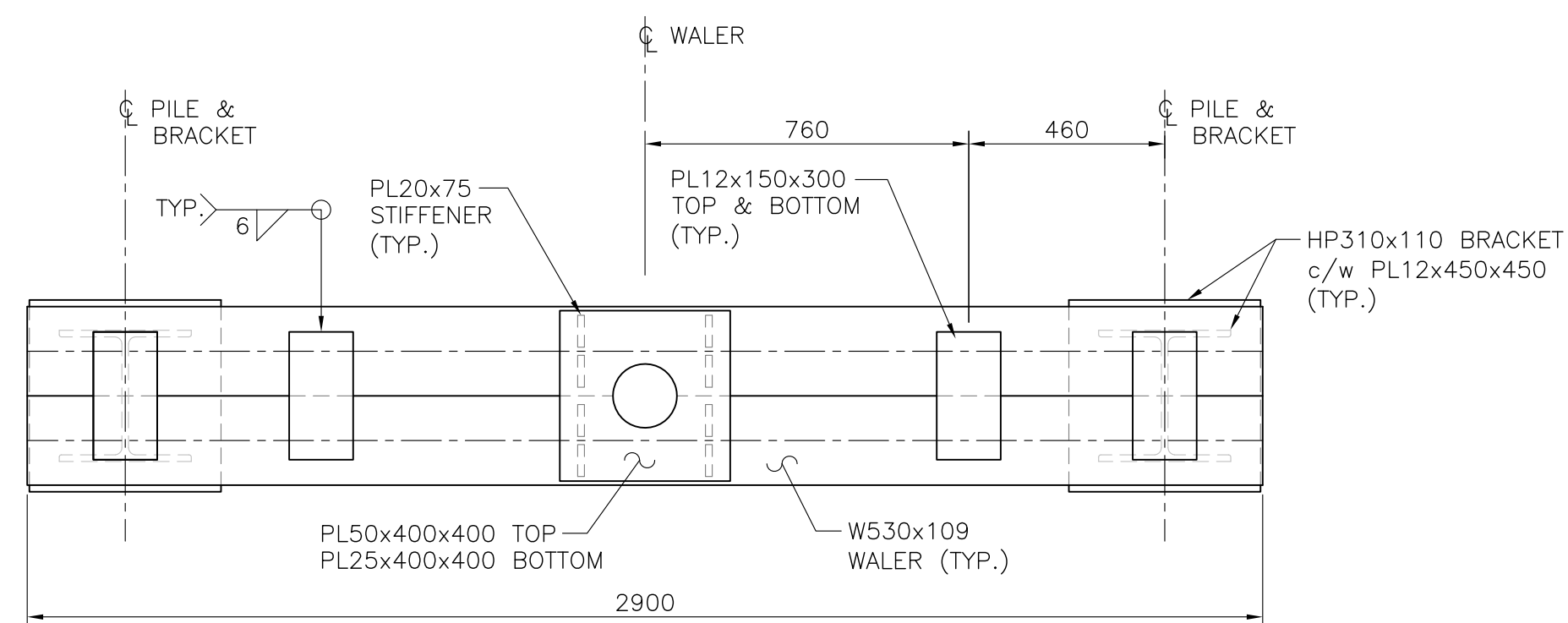

J
1:15

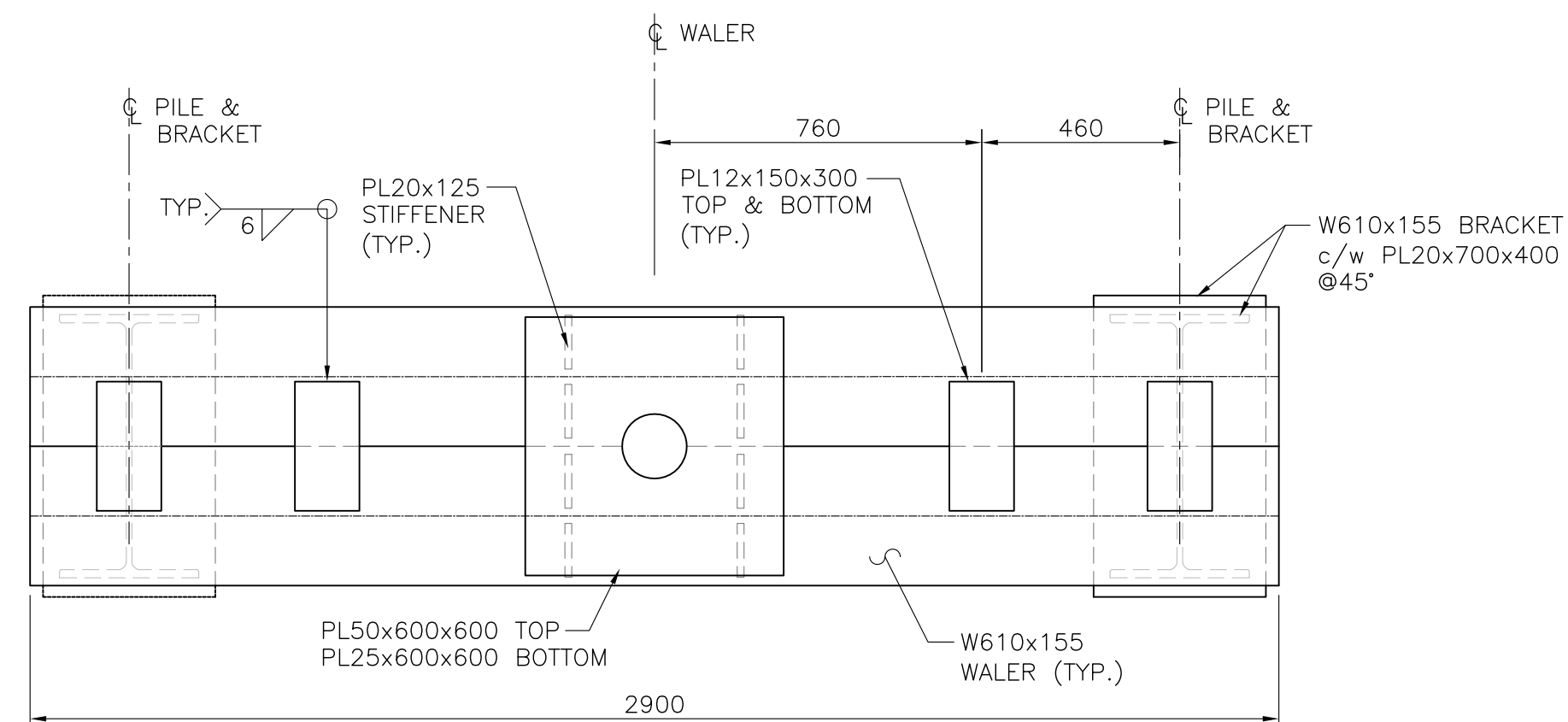

L
1:15

THE LOCATION OF UTILITIES IS APPROXIMATE ONLY, AND THE EXACT LOCATION SHOULD BE DETERMINED BY CONSULTING THE MUNICIPAL AUTHORITIES AND UTILITY COMPANIES CONCERNED. THE CONTRACTOR SHALL PROVE THE LOCATION OF UTILITIES AND SHALL BE RESPONSIBLE FOR ADEQUATE PROTECTION FROM DAMAGE DURING CONSTRUCTION.



No.	Date	Revision	By:
4	MAR. 31/22	REVISED AS PER D+M REVIEW	W.R.
3	JUL. 19/21	UPDATED GEOTECH REPORT DATA	R.P.
2	MAY 27/21	REVISED FOR NEW UNDERGROUND	R.P.
1	MAR. 10/21	REVISED FOR SHEET PILES E&W	R.P.
0	FEB. 22/21	PRELIMINARY	R.P.



57 Auriga Dr. Suite 102
Ottawa, ON, K2E 8B2
tel.: (613) 225-1162
fax: (613) 225-4529

Client

CLARIDGE HOMES

Project

1040 SOMERSET St. W
OTTAWA, ONTARIO

Drawing

EXCAVATION PROTECTION SYSTEM
BOX-WALER DETAILS

Designed	R.P. / M.K.	Date	JAN. 2021
Drawn	R.P. / M.K.	Scale	AS SHOWN
Checked	B.U. / W.R.	Sheet	9 OF 10
Project No.	2021-010-3	Dwg. No.	C-09

