

Site Servicing & Stormwater Management Report

Building Expansion 64 Cleopatra Drive

City of Ottawa

**Old Project No. 15031-1
New Project No. 19028-1**

Prepared for:

2336925 Ontario Inc.
64 Cleopatra Drive
Ottawa, Ontario
K2G 0B4

**June 26, 2015
Rev. June 19, 2020
Rev. June 7, 2021**



CONSULTING
ENGINEERS
PLANNERS

TABLE OF CONTENTS

1.0	INTRODUCTION	1
2.0	WATER SERVICE	1
3.0	SANITARY SEWER SERVICE	2
4.0	DRAINAGE & STORM WATER SYSTEM	2
4.1	5 Year Pre-Development Flow	3
4.2	100 Year Post-Development Flow (Area A1)	4
4.3	100 Year Post-Development Flow (Area A2)	4
4.4	100 Year Post-Development Flow (Area A3)	4
4.5	Storage Requirements	5
5.0	EROSION AND SEDIMENT CONTROL	5
6.0	CONCLUSION	6

APPENDIX A

- Table 1: Storm Water Management Summary Sheet
- Table 2 – 4: Storage Tables
- City of Ottawa Correspondence re. stormwater quantity requirements.

APPENDIX B

- FUS Calculations
- Boundary Conditions incl. Correspondence

APPENDIX C

- Existing Well Record
- RVCA correspondence re. stormwater quality requirements
- City of Ottawa correspondence re. ECA
- MOE correspondence re. ECA
- Existing C of A – Downstream Pond
- Hydrovex Sizing Form
- Proposed Detention Area Volume Calculations

APPENDIX D

- Removal and Adjustment (Dwg. 001-19028-REM1)
- Storm Drainage Area Plan (Dwg. 002-19028-STM1)
- Site Servicing and Grading Plan (Dwg. 003-19028-SG1)
- Erosion and Sediment Control Plan (Dwg. 004-19028-SC1)

1.0 INTRODUCTION

The subject site is located on the west side of Cleopatra Drive (#64), at the west end of Caesar Avenue in the City of Ottawa. The site currently has an existing two (2) storey industrial/office building and an asphalt parking lot. The existing building is to remain and shall be expanded with a proposed one (1) storey addition of approximately 4,185sq.ft. The existing asphalt parking lot (i.e. along the east and south sides of the existing building) will be reconfigured; therefore, increasing the landscaped area which in return reduces the imperviousness of the site. The north side of the existing building (i.e. gravel parking lot / storage area), will be removed to accommodate the new building addition. The overall site has an area of 0.28ha, however only 0.066ha is being redeveloped.

The existing building is serviced from a 10 inch (250mm) diameter sanitary sewer along Cleopatra Drive. As for water, the site is currently serviced by an on-site well. Approximately half the site drains overland to the existing hydro easement along the west side of the site, where as the other half of the site drains overland easterly ultimately draining to catchbasins along Cleopatra Drive.

A site investigation was undertaken to verify the existing site conditions and to establish the impact the new building expansion would have on the site. The City of Ottawa was contacted to verify existing civil infrastructure services along Cleopatra Drive and information on the servicing requirements for this project.

2.0 WATER SERVICE

As mentioned above, the building is currently serviced by an on-site water well. The intent is to decommission the existing water well and connect to the existing 12 inch (300mm) diameter watermain along Cleopatra Drive. Using the City of Ottawa guideline of 35 cu.m/ha.d for light industrial use, the anticipated average daily demand for the site has been calculated at 9.8cu.m/day or 0.116L/s. Therefore, the anticipated peak hourly rate shall be in the magnitude of 0.21L/s, which is minimal. No fire sprinklers are anticipated at this time.

The anticipated fire flow (based on the Fire Underwriters Survey) was calculated to be 7,000 L/min or **116.7 L/s**. A detailed calculation can be seen in Appendix B.

The following are boundary conditions provided by the City (i.e. Justin Armstrong on May 30, 2019 – correspondence attached in Appendix B):

Minimum HGL = 126.5m
Maximum HGL = 134.0m
Max Day + Fire Flow = 126.0m

Based on a ground elevation of 90.15m:

Minimum HGL = 51.7 psi
Maximum HGL = 62.4 psi
Max Day + Fire Flow = 51.0 psi

Ainley has reviewed the results of the City of Ottawa hydraulic analysis and find that they meet the requirements set out by the ODG for water distribution, as seen below:

- Normal operating pressure ranges between 50 psi and 80 psi under a condition of maximum daily flow.
- Under maximum hourly demand conditions, the pressures are not less than 40 psi.
- During periods of maximum day and fire flow demand, the residual pressure at any point in the distribution system shall not be less than 20 psi.
- The maximum pressure at any point in the distribution system in occupied areas outside of the public right-of-way shall not exceed 80 psi.
- The maximum pressure at any point in the distribution system in unoccupied areas shall not exceed 100 psi.

With regards to the existing well, we note that the UTM coordinates from the well record don't seem to line up correctly with the property; however, does state that the well is in fact on the property (please see attached Well Record in Appendix C). Decommissioning must be done by a licensed well contractor in accordance with Wells Regulation (R.R.O 1990 Regulation 903) as per Ontario Water Resource Act.

3.0 SANITARY SEWER SERVICE

As mentioned above, the site is currently serviced from a 10 inch (250mm) diameter sanitary sewer along Cleopatra Drive. Under City of Ottawa policy, secondary sanitary service connections to a property are not generally permitted. The intent is to provide a new sanitary service (decommissioning and/or removing the old service), and branching off a secondary line (on-site) towards the new building addition at a proposed Sanitary MH. The secondary line to the new building addition is intended to service the floor drains only, therefore no additional flows are expected.

4.0 DRAINAGE & STORM WATER SYSTEM

The stormwater management facility for this development has been designed to attenuate the release of stormwater runoff from the redeveloped area of the site to a rate not greater than the 5 year pre-development runoff rate of 9.5 l/s, (i.e. see correspondence from the City of Ottawa in Appendix A confirming the quantity control criteria for the site).

We note that in pre-development conditions, the entire proposed redeveloped area drains towards the west side of the site (i.e. not towards the municipal right of way). Due to the existing topography, a small section of the proposed redeveloped area (drainage area A-3) will drain uncontrolled to the west side of the site. As well, a small section of the proposed redeveloped area (drainage area A-2) will drain uncontrolled to the east towards Cleopatra Drive. Therefore, over controlling drainage area A-1 (proposed building and grassed area to the north) will be required.

This has been achieved by installing an inlet control device (i.e. Vertical Hydrovex Valve – see Appendix C) in the ditch inlet catchbasin and by providing the appropriate ponding volume within the swale/ditch system, (refer to Detention Area Volume Calculations in Appendix C). We note that the emergency overland flow high point will be set at 0.18m below the finished floor elevation. Flows from A1 will be directed to the ditch storage via eavestrough. Due to the nature of the site (industrial area, no basement, overland flow not to right of way), there is limited opportunity for property damage to occur should this overland flow fail to convey the flow from this small area. Nonetheless, this overland flow highpoint elevation meets the requirements of the current City of Ottawa OSDG for the elevations of overland flow high points compared to finished floors.

Since the proposed redeveloped area is primarily building (which typically doesn't require stormwater quality treatment – considered clean water); that the proposed reconfiguration of the existing parking lot does not change the existing drainage pattern and increases the landscaped area which in return reduces the imperviousness of the site; and, that the existing industrial subdivision drains to an existing stormwater management pond/facility, we note that no stormwater quality requirements are required for this site (i.e. see correspondence from the RVCA in Appendix C).

Also, based on our pre-consultation with Ministry of the Environment (i.e. Charlie Primeau – Water Compliance Supervisor) on June 5, 2019 and subsequent correspondence with the City of Ottawa, an Industrial ECA (direct submission) will be required for this project. Correspondence from the MOE, City of Ottawa and a copy of the existing C of A for the downstream storm water pond received by the City of Ottawa has been included in the report for reference in Appendix C.

4.1 5 YEAR PRE-DEVELOPMENT FLOW

$$Q = R \times A \times I \times N$$

Redeveloped Site Area	A =	0.066 hectares
Runoff Coefficient	R =	0.50 (gravel)
Time of Concentration	Tc =	10 min

4.5 STORAGE REQUIREMENTS

As noted previously, the site has been designed to limit the rate of runoff (for the redeveloped portion of the site) to the 5 year pre-development release rate of 9.5 l/s for rainfall events up to and including the 100 year post-development event.

Over controlling Area A1 to 4.8 l/s [9.5 l/s (pre-dev.) – 1.2 l/s (Area A2) – 3.4 (area A3)] ensures the 5 year pre-development release rate of 9.5 l/s is achieved.

Storage volume requirements were determined by applying the 5-year and 100-year rainfall intensity values at 10-minute intervals until a peak storage volume was attained.

Return Period	Time (min)	Intensity (mm/hr)	Flow Q (L/s)	Controlled Release	Net Runoff To Be Stored (L/s)	Storage Req'd m3
5 Year	10	104.19	11.00	4.8	6.2	3.7
	20	70.25	7.42	4.8	2.6	3.1
	30	53.93	5.69	4.8	0.9	1.6
	40	44.18	4.67	4.8	-0.1	-0.3
	50	37.65	3.98	4.8	-0.8	-2.5
100 Year	10	178.56	18.85	4.8	14.0	8.4
	20	119.95	12.66	4.8	7.9	9.4
	30	91.87	9.70	4.8	4.9	8.8
	40	75.15	7.93	4.8	3.1	7.5
	50	63.95	6.75	4.8	1.9	5.8

Therefore, the resulting 100-year release rate from the redeveloped portion of the site is less/equal to the allowable release rate of 9.5 l/s by providing 9.4 cu.m of storage within the swale/ditch system on the north side of the proposed building expansion.

5.0 EROSION AND SEDIMENT CONTROL

Erosion and sediment control measures shall be implemented during construction to minimize the migration of sediments from the proposed construction. To accomplish this task, items such as silt fences, and geo-textile membranes shall be installed to capture sediment before it leaves the construction areas. In addition, all stockpiles shall be covered and located away from waterways and exposed areas and shall be vegetated as soon as possible. During construction, all erosion control features shall be maintained and repaired as necessary and adjacent roadways kept free of debris and sediment as required. Drawing 19028 - SC1 shows detailed requirements for erosion and sediment control.

6.0 CONCLUSION

1. The intent is to decommission the existing water well and connect to the existing 300mm diameter watermain along Cleopatra Drive. The anticipated peak hourly rate has been calculated at 0.21 L/s. The fire flow water demand has been calculated at 116.7 L/s. No fire sprinklers are anticipated at this time.
2. No increase in sanitary flows is anticipated.
3. The redeveloped portion of the site has been designed to limit the rate of runoff to the 5 year pre-development release rate for rainfall events up to and including the 100 year post-development event.
4. Erosion and sediment control has been incorporated into the contract drawings.
5. An Industrial ECA (direction submission) will be required for this project and will be completed / submitted separately.

We trust that this report meets all of your requirements. Should you have any questions or require further clarification, please do not hesitate to contact our office.

Sincerely,

Prepared by:

Ainley Graham and Associates Ltd.

Reviewed by:

Ainley Graham and Associates Ltd.



Professional Engineers

Ontario

June 07, 2021

Limited Licensee

Name: J.W.XU

Number: 100171806

Category: CIVIL: see limitation

Limitations:

This licence is subject to the limitations as detailed on the certificate.

Association of Professional Engineers of Ontario

Jiawu Xu, LEL, C.E.T.
Project Manager

Guy Ste-Croix, LEL, C.E.T.,PMP
Branch Manager

APPENDIX A

- Table 1: Storm Water Management Summary Sheet
- Table 2 – 4: Storage Tables
- City of Ottawa Correspondence re. stormwater quantity requirements.

AINLEY Project: 19028-64 CLEOPATRA DRIVE
Location: 64 CLEOPATRA DRIVE
Client: City Of Ottawa

Table 1. Stormwater Management Summary Sheet

Sub Area I.D.	Sub Area (ha)	C = 0.2	C = 0.6	C = 0.9	Composite 'C'	Outlet Location	Controlled Release (L/s)	Top of Grate (m)	Ponding Depth (m)	Invert or Pan Elev. (m)	Pipe dia (if plug type) (mm)	Head on Orifice (if plug) (m)	Diameter of Orifice (mm)	Hydrovex Model	Head on Hydrovex
A1	0.053	0.014	0.000	0.039	0.72	DICB 1	4.8	89.53	0.62	88.10	250	1.93	41	75VHV-1	2.05
A2	0.006	0.004	0.000	0.002	0.43	FREE FLOW	1.2								
A3	0.008	0.000	0.000	0.008	0.90	FREE FLOW	3.4								

9.4

Table 2-Storage Requirements for AREA 1						
Area		0.05	hectares			
Runoff Coefficient =		0.72	post development			
Return Period	Time (min)	Intensity (mm/hr)	Flow Q (L/s)	Controlled Release	Net Runoff To Be Stored (L/s)	Storage Req'd m3
5 Year	10	104.19	11.00	4.8	6.2	3.7
	20	70.25	7.42	4.8	2.6	3.1
	30	53.93	5.69	4.8	0.9	1.6
	40	44.18	4.67	4.8	-0.1	-0.3
	50	37.65	3.98	4.8	-0.8	-2.5
100 Year	10	178.56	18.85	4.8	14.0	8.4
	20	119.95	12.66	4.8	7.9	9.4
	30	91.87	9.70	4.8	4.9	8.8
	40	75.15	7.93	4.8	3.1	7.5
	50	63.95	6.75	4.8	1.9	5.8

Table 3-Storage Requirements for AREA 2						
Area		0.01	hectares			
Runoff Coefficient =		0.43	post development			
Return Period	Time (min)	Intensity (mm/hr)	Flow Q (L/s)	Controlled Release	Net Runoff To Be Stored (L/s)	Storage Req'd m3
5 Year	10	104.19	0.68	1.2	-0.5	-0.3
	20	70.25	0.46	1.2	-0.7	-0.9
	30	53.93	0.35	1.2	-0.8	-1.5
	40	44.18	0.29	1.2	-0.9	-2.2
	50	37.65	0.25	1.2	-1.0	-2.9
100 Year	10	178.56	1.17	1.2	0.0	0.0
	20	119.95	0.79	1.2	-0.4	-0.5
	30	91.87	0.60	1.2	-0.6	-1.1
	40	75.15	0.49	1.2	-0.7	-1.7
	50	63.95	0.42	1.2	-0.8	-2.3

Table 4-Storage Requirements for AREA 3						
Area		0.01	hectares			
Runoff Coefficient =		0.90	post development			
Return Period	Time (min)	Intensity (mm/hr)	Flow Q (L/s)	Controlled Release	Net Runoff To Be Stored (L/s)	Storage Req'd m3
5 Year	10	104.19	1.98	3.4	-1.4	-0.9
	20	70.25	1.34	3.4	-2.1	-2.5
	30	53.93	1.03	3.4	-2.4	-4.3
	40	44.18	0.84	3.4	-2.6	-6.1
	50	37.65	0.72	3.4	-2.7	-8.1
100 Year	10	178.56	3.40	3.4	0.0	0.0
	20	119.95	2.28	3.4	-1.1	-1.3
	30	91.87	1.75	3.4	-1.7	-3.0
	40	75.15	1.43	3.4	-2.0	-4.7
	50	63.95	1.22	3.4	-2.2	-6.6

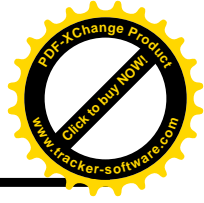
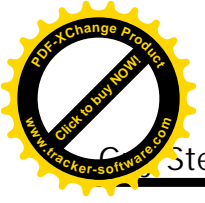

Ste-Croix

From: Kuruvilla, Santhosh <Santhosh.Kuruvilla@ottawa.ca>
Sent: February 22, 2021 12:01 PM
To: Guy Ste-Croix
Cc: mdblakely_jon@bellnet.ca
Subject: FW: D07-12-16-0029 - 64 Cleopatra Drive - 2nd Review Comments
Attachments: D07-12-16-0029 - Cleopatra Drive - 2nd Review Comments.pdf

Good morning Guy,

I just want to let you know that the quantity control criteria that you used in your report for this site is the correct one (i.e. 5-year flow based on the lesser of $C=0.5$ or existing). This is related to comment #19 in the attached comment.

If you have any questions, please let me know.

Thanks,

Santhosh

From: Gorni, Colette <colette.gorni@ottawa.ca>
Sent: February 19, 2021 4:56 PM
To: mdblakely_jon@bellnet.ca
Cc: Kuruvilla, Santhosh <Santhosh.Kuruvilla@ottawa.ca>; Gorni, Colette <colette.gorni@ottawa.ca>
Subject: D07-12-16-0029 - 64 Cleopatra Drive - 2nd Review Comments

Good afternoon Jonathan,

Please find attached the City's comments on the engineering portion of the second submission of the Site Plan Control application for 64 Cleopatra Drive.

Kind regards,

Colette Gorni

Planner I | Urbaniste I
Development Review West | Services d'examen demandes d'aménagements Ouest
Planning, Infrastructure and Economic Development Department
City of Ottawa | Ville d'Ottawa
613-580-2424, ext./poste 21239
Colette.Gorni@ottawa.ca

During this period of uncertainty surrounding COVID-19, we are following best practices recommended to minimize the risk of exposure, while ensuring that service to our clients remains as uninterrupted as possible. For the most part I am working from home and will respond to emails at my earliest opportunity.

APPENDIX B

- FUS Calculations
- Boundary Conditions incl. Correspondence

MEMORANDUM

Ainley Graham & Associates Limited
2724 Fenton Road, Gloucester, ON K1T 3T7
Tel: (613) 822-1052 • Fax: (613) 822-1573
Email: ottawa@ainleygroup.com

To: **Justin Armstrong**
City of Ottawa

Copies to: Guy Ste-Croix
Branch Manager
Ainley Group

From: Paul Le Blanc
EIT

Ainley Group

Date: 02/05/2019

Ref: **64 Cleopatra Drive (D07-12-16-0029)**

File: **19028-1**

Attached: N/A

It is understood that FUS calculations are required to determine the boundary conditions

64 Cleopatra Fire Flow

Step	Parameter	Value	Note
A	Type of Construction	Ordinary	Assumed Steel construction with combustible interior components
	Coefficient related to the type of construction	C = 1.0	
B	Ground Floor Area	N/A	Considering that some floors are of differing areas (mezzanine, attic storage of ex building), only the total floor area is given, as below
C	Height in Storeys	3 storeys in existing building, 1 storey plus Mezzanine in proposed building	
	Total floor area:	A = 924.4 m ²	
D	Fire flow:	$F = 220 C A^{0.5}$ $= 220 \times 1.0 \times (924.4)^{0.5}$ $= 6\ 688.87\ \text{L/min}$ $= 7\ 000\ \text{L/min}$	Flow rounded to the nearest 1000 L/min.
E	Occupancy class	Combustible	Given that this building will be used as a mechanical garage, and this use is not listed as either low or high hazard occupancy,
	Occupancy Charge	0%	
	Occupancy increase or decrease	7 000 L/min x 0% = 0 L/min	

	Fire Flow	F = 11 000 L/min + - 0 L/min F = 7 000 L/min	No rounding applied.
F	Sprinkler Protection	Not Included	It is understood that this building will not be equipped with a sprinkler system.
	Sprinkler credit	0%	
	Sprinkler FF reduction	7 000 x 0% = 0 L/min	
G	West side exposure:	Exposing wall: Ordinary type construction Distance: over 45 m	No exposed wall within 45 meters of the proposed structure
	West side exposure charge:	0%	
	North side exposure:	Exposing wall: Ordinary type construction Distance: over 45 m	No exposed wall within 45 meters of the proposed structure
	North side exposure charge:	0%	
	East side exposure:	Exposing wall: Ordinary type construction Distance: 36.9 m	Exposed wall of Ordinary construction
	East side exposure charge:	5%	
	South Side Exposure:	Exposing wall: Ordinary type construction Distance: over 45 m	No exposed wall within 45 meters of the proposed structure
	South side exposure charge:	0%	
	Total exposure charge:	= 0% + 0% + 5% + 0% = 5%	The total exposure charge is below the maximum value of 75%.
	Increase for exposures:	= 7 000 L/min x 5% = 350 L/min	
H	Fire flow	F = 7 000 L/min + 350 L/min F = 7 350 L/min = 7 000 L/min = 116.7 L/s	Flow rounded to nearest 1000 L/min.

Thus, to conclude;

- Fire Flow for the proposed building (considering the existing building and proposed building as a single fire area) will be **116.7 L/s**.

Prepared by:

AINLEY GRAHAM & ASSOCIATES LIMITED

A handwritten signature in black ink, appearing to read 'P. Le Blanc', with a stylized flourish at the end.

Paul Le Blanc, EIT
Engineer in Training
Ainley Group

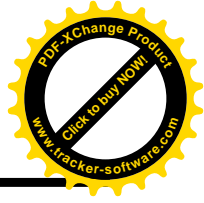
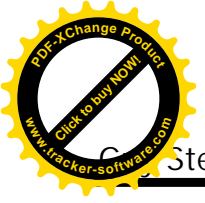

Ste-Croix

From: Armstrong, Justin <justin.armstrong@ottawa.ca>
Sent: May 30, 2019 11:34 AM
To: 'Paul Le Blanc'
Cc: Guy Ste-Croix; xu@ainleygroup.com
Subject: RE: D07-12-16-0029 64 Cleopatra Drive - Water Boundary card request
Attachments: 64 Cleopatra May 2019.pdf

Hi Paul,

Please see boundary conditions below as well as assumed connection point in attached PDF.

The following are boundary conditions, HGL, for hydraulic analysis at 64 Cleopatra (zone 2C) assumed to be connected the 305mm on Cleopatra (see attached PDF for location).

Minimum HGL = 126.5m

Maximum HGL = 134.0m

MaxDay + FireFlow (117 L/s) = 126.0m

These are for current conditions and are based on computer model simulation.

Disclaimer: The boundary condition information is based on current operation of the city water distribution system. The computer model simulation is based on the best information available at the time. The operation of the water distribution system can change on a regular basis, resulting in a variation in boundary conditions. The physical properties of watermains deteriorate over time, as such must be assumed in the absence of actual field test data. The variation in physical watermain properties can therefore alter the results of the computer model simulation.

Regards,

Justin Armstrong, E.I.T.

Engineering Intern

Planning, Infrastructure and Economic Development Department - Services de la planification, de l'infrastructure et du développement économique

Development Review - West Branch

City of Ottawa | Ville d'Ottawa

110 Laurier Avenue West Ottawa, ON | 110, avenue. Laurier Ouest. Ottawa (Ontario) K1P 1J1

613.580.2400 ext./poste 21746, justin.armstrong@ottawa.ca

From: Paul Le Blanc <leblanc@ainleygroup.com>
Sent: May 28, 2019 3:08 PM
To: Armstrong, Justin <justin.armstrong@ottawa.ca>
Cc: 'Guy Ste-Croix' <stecroix@ainleygroup.com>; xu@ainleygroup.com
Subject: RE: D07-12-16-0029 64 Cleopatra Drive - Water Boundary card request

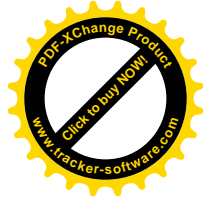
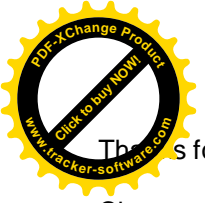

Thanks for the update!

Cheers,

Paul Le Blanc, EIT
Engineering Intern



Ainley Graham & Associates Limited
2724 Fenton Road
Ottawa, Ontario, K1T 3T7
Tel: (613) 822-1052 ext. 229
Fax: (613) 822-1573
Cell: (613) 222-4346
leblanc@ainleygroup.com

CAUTION: The information contained in and/or attached to this transmission is solely for the use of the intended recipient. Any copying, distribution or use by others, without the express written consent of the Ainley Group, is strictly prohibited. The recipient is responsible for confirming the accuracy and completeness of the information with the originator. Please advise the sender if you believe this message has been received by you in error.

From: Armstrong, Justin [<mailto:justin.armstrong@ottawa.ca>]
Sent: May-28-19 2:16 PM
To: 'Paul Le Blanc'
Cc: Guy Ste-Croix; xu@ainleygroup.com
Subject: RE: D07-12-16-0029 64 Cleopatra Drive - Water Boundary card request

Hi Paul,

I circulated your request to our boundary conditions group on Friday. I believe they have 10 business days to provide boundary conditions. They will sometimes provide them sooner depending on how backlogged they are. I will keep you informed.

Justin

Justin Armstrong, E.I.T.

Engineering Intern
Planning, Infrastructure and Economic Development Department - Services de la planification, de l'infrastructure et du développement économique
Development Review - West Branch
City of Ottawa | Ville d'Ottawa
110 Laurier Avenue West Ottawa, ON | 110, avenue. Laurier Ouest. Ottawa (Ontario) K1P 1J1
613.580.2400 ext./poste 21746, justin.armstrong@ottawa.ca

From: Paul Le Blanc <leblanc@ainleygroup.com>
Sent: May 28, 2019 12:37 PM
To: Armstrong, Justin <justin.armstrong@ottawa.ca>



Cc: Guy Ste-Croix <stecroix@ainleygroup.com>; xu@ainleygroup.com
 Subject: FW: D07-12-16-0029 64 Cleopatra Drive - Water Boundary card request

Hello Justin;

Just following up on the below boundary condition request. Please let me know if you have any questions.

Cheers,

Paul Le Blanc, EIT
 Engineering Intern



Ainley Graham & Associates Limited
 2724 Fenton Road
 Ottawa, Ontario, K1T 3T7
 Tel: (613) 822-1052 ext. 229
 Fax: (613) 822-1573
 Cell: (613) 222-4346
leblanc@ainleygroup.com

CAUTION: The information contained in and/or attached to this transmission is solely for the use of the intended recipient. Any copying, distribution or use by others, without the express written consent of the Ainley Group, is strictly prohibited. The recipient is responsible for confirming the accuracy and completeness of the information with the originator. Please advise the sender if you believe this message has been received by you in error.

From: Paul Le Blanc [<mailto:leblanc@ainleygroup.com>]
 Sent: May-15-19 12:10 PM
 To: 'Armstrong, Justin'
 Cc: 'Guy Ste-Croix'; 'mary.dickinson@ottawa.ca'; 'mark.young@ottawa.ca'
 Subject: RE: D07-12-16-0029 64 Cleopatra Drive - Water Boundary card request

Hi Justin;

Thank you for responding to our request. I have included the information requested below;

- An image of the site indicating the location of the site's proposed water connection to the City main.
See attached servicing drawing snapshot
- Average daily demand
0.116 L/s
- Maximum daily demand
0.175 L/s
- Peak hour demand
0.210 L/s
- Required fire flow based on the FUS method (see attached Technical Bulletin ISTB-2018-02 which outlines the FUS method in detail)
116.67 L/s - See attached memorandum for calculations

Cheers,

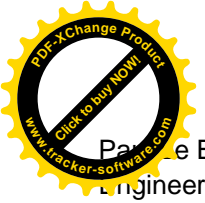

Paul Le Blanc, EIT
Engineering Intern



Ainley Graham & Associates Limited
2724 Fenton Road
Ottawa, Ontario, K1T 3T7
Tel: (613) 822-1052 ext. 229
Fax: (613) 822-1573
Cell: (613) 222-4346
leblanc@ainleygroup.com

CAUTION: The information contained in and/or attached to this transmission is solely for the use of the intended recipient. Any copying, distribution or use by others, without the express written consent of the Ainley Group, is strictly prohibited. The recipient is responsible for confirming the accuracy and completeness of the information with the originator. Please advise the sender if you believe this message has been received by you in error.

From: Armstrong, Justin [<mailto:justin.armstrong@ottawa.ca>]
Sent: May-07-19 8:36 AM
To: Oram, Cody; 'Paul Le Blanc'; Young, Mark
Cc: Guy Ste-Croix
Subject: RE: D07-12-16-0029 64 Cleopatra Drive - Water Boundary card request

Hi Paul,

In order to have boundary conditions generated for the site, please provide the following:

- An image of the site indicating the location of the site's proposed water connection to the City main.
- Average daily demand
- Maximum daily demand
- Peak hour demand
- Required fire flow based on the FUS method (see attached Technical Bulletin ISTB-2018-02 which outlines the FUS method in detail)

Regards,

Justin Armstrong, E.I.T.

Engineering Intern
Planning, Infrastructure and Economic Development Department - Services de la planification, de l'infrastructure et du développement économique
Development Review - West Branch
City of Ottawa | Ville d'Ottawa
110 Laurier Avenue West Ottawa, ON | 110, avenue. Laurier Ouest. Ottawa (Ontario) K1P 1J1
613.580.2400 ext./poste 21746, justin.armstrong@ottawa.ca

Boundary Condition for 64 Cleopatra

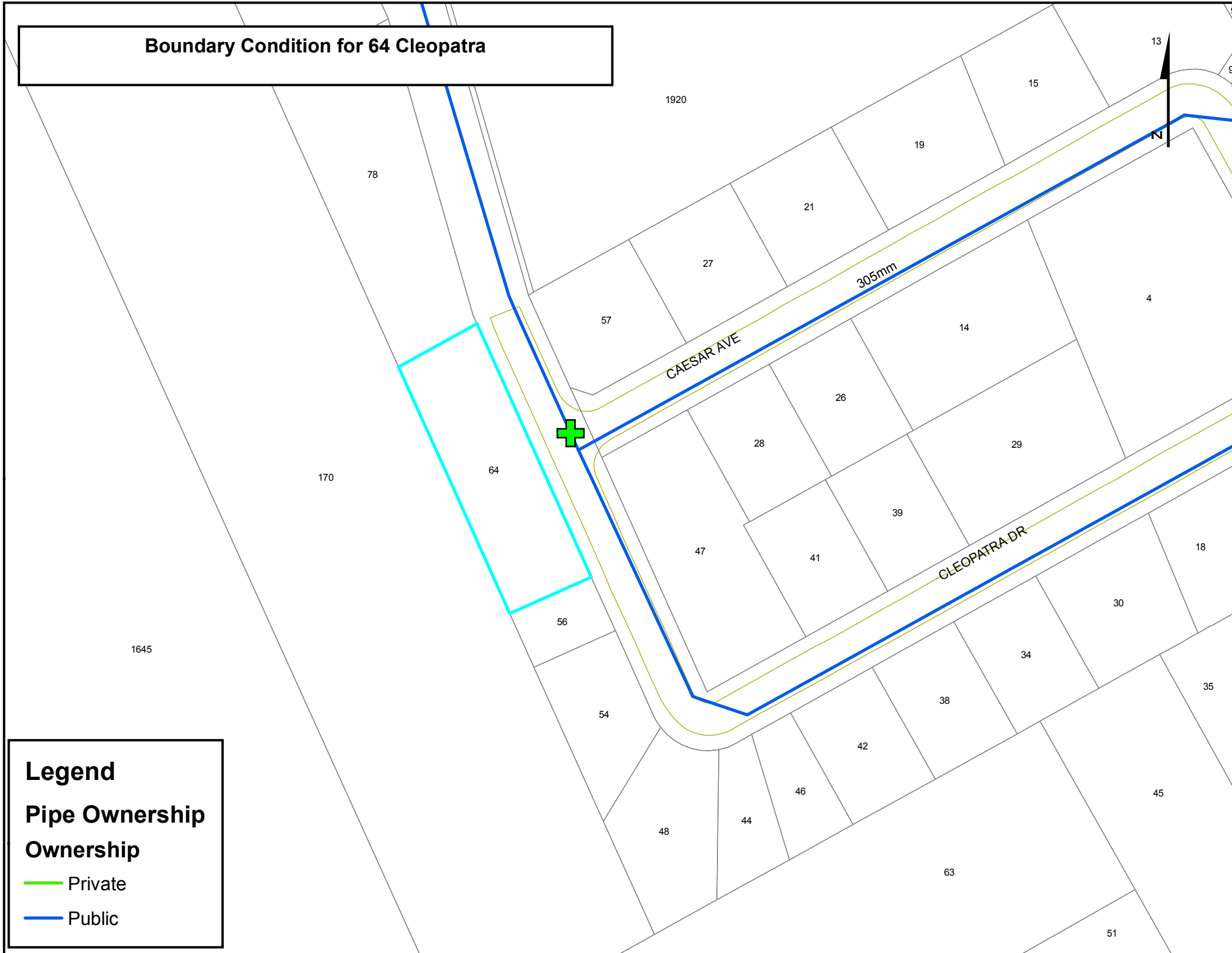

Legend

Pipe Ownership

Ownership

Private

Public

APPENDIX C

- Existing Well Record
- RVCA correspondence re. stormwater quality requirements
- City of Ottawa correspondence re. ECA
- MOE correspondence re. ECA
- Existing C of A – Downstream Pond
- Hydrovex Sizing Form
- Proposed Detention Area Volume Calculations

3



WATER RESOURCES DIVISION
DEC 14 1966
15 No
1966
ONTARIO WATER RESOURCES COMMISSION

2
1996

UTM 18Z 44311010E

31G5b

5R 501192310N

The Ontario Water Resources Commission Act

Elev. 4R 0295

WATER WELL RECORD

Basin 251 | Pall
County or District
Township, Village, Town or City Nepean
Con. 1 RF Lot 26' Date completed 29 July 1966
(day month year)
Owner Murray Gray Ltd Address 6 Hastings RR#2 Bells Corners
(print in block letters)

Casing and Screen Record	Pumping Test
Inside diameter of casing 5"	Static level 15'
Total length of casing 38'	Test-pumping rate 10 G.P.M.
Type of screen	Pumping level 40'
Length of screen	Duration of test pumping 1 hr
Depth to top of screen	Water clear or cloudy at end of test cloudy
Diameter of finished hole 5"	Recommended pumping rate 5 G.P.M.
	with pump setting of 50' feet below ground surface

Well Log	Water Record			
Overburden and Bedrock Record	From ft.	To ft.	Depth(s) at which water(s) found	Kind of water (fresh, salty, sulphur)
sand	0'	6'	68'	fresh
clay	6'	15'		
sand & boulders	15'	32'		
limestone	32'	70'		

For what purpose(s) is the water to be used? office & repair garage
Is well on upland, in valley, or on hillside? upland
Drilling or Boring Firm Capital Water Supply
Address 14 Ashford Dr Ottawa 828-1764
Licence Number 2158
Name of Driller or Borer H Mains
Address
Date July 29 1966
Halter Kavanagh
(Signature of Licensed Drilling or Boring Contractor)

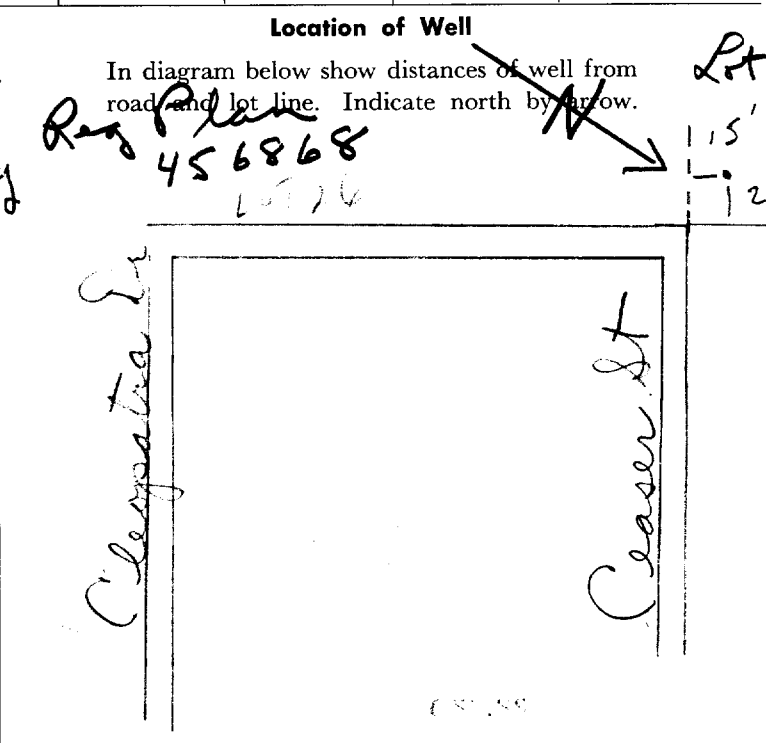

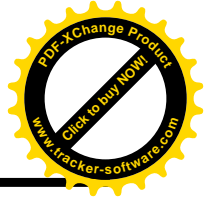
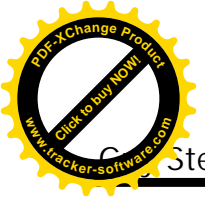

Ste-Croix

From: Jamie Batchelor <jamie.batchelor@rvca.ca>
Sent: May 31, 2021 4:05 PM
To: Guy Ste-Croix; Eric Lalande
Subject: RE: 64 Cleopatra Drive

Good Afternoon Guy,

The only thing I would add is that no additional water quality control is required because the repaved area is within the same footprint, with no new infrastructure proposed and is currently sheet drained to an existing grassed area at the rear of the property which currently provides some water quality treatment.

Jamie Batchelor, MCIP, RPP
Planner, ext. 1191
jamie.batchelor@rvca.ca



3889 Rideau Valley Drive
PO Box 599, Manotick ON K4M 1A5
T 613-692-3571 | 1-800-267-3504 F 613-692-0831 | www.rvca.ca

This message may contain information that is privileged or confidential and is intended to be for the use of the individual(s) or entity n may contain confidential or personal information which may be subject to the provisions of the *Municipal Freedom of Information & I* you are not the intended recipient of this e-mail, any use, review, revision, retransmission, distribution, dissemination, copying, printing, taking of any action in reliance upon this e-mail, is strictly prohibited. If you have received this e-mail in error, please contact the send and any copy of the e-mail and any printout thereof, immediately. Your cooperation is appreciated.

From: Guy Ste-Croix <stecroix@ainleygroup.com>
Sent: Monday, May 17, 2021 4:34 PM
To: Jamie Batchelor <jamie.batchelor@rvca.ca>; Eric Lalande <eric.lalande@rvca.ca>
Subject: RE: 64 Cleopatra Drive

Hi Jamie,

Per our meeting earlier today, we summarize the following:

- The building addition / expansion area at 64 Cleopatra Drive in Ottawa is considered 'clean water' (i.e. primarily building / roof and grass area); therefore, no stormwater quality is required.
- With regards to the reconfiguration of the existing parking lot, we note that a small section will be repaved and other sections of asphalt will be removed all together. The proposed reconfiguration of the existing parking lot does not change the existing drainage pattern and increases the landscaped area which in return reduces the imperviousness of the site; therefore, no stormwater quality is required.

We ask that you please acknowledge receipt and confirmation of the above noted statements, so this can be included in our SWM report.

Regards,



Guy Ste-Croix, LEL, C.E.T., PMP
Branch Manager



Ainley Graham & Associates Limited
2724 Fenton Road
Ottawa, Ontario, K1T 3T7
Tel: (613) 822-1052 ext. 225
Fax: (613) 822-1573
Cell: (613) 858-8943
stecroix@ainleygroup.com

CAUTION: The information contained in and/or attached to this transmission is solely for the use of the intended recipient. Any copying, distribution or use by others, without the express written consent of the Ainley Group, is strictly prohibited. The recipient is responsible for confirming the accuracy and completeness of the information with the originator. Please advise the sender if you believe this message has been received by you in error.

From: Guy Ste-Croix
Sent: May 13, 2021 2:26 PM
To: Jamie Batchelor <jamie.batchelor@rvca.ca>; Eric Lalande <eric.lalande@rvca.ca>
Subject: RE: 64 Cleopatra Drive

Hi Jamie – yes, I'm available Monday May 17th at 10am.

Guy Ste-Croix, LEL, C.E.T., PMP
Branch Manager



Ainley Graham & Associates Limited
2724 Fenton Road
Ottawa, Ontario, K1T 3T7
Tel: (613) 822-1052 ext. 225
Fax: (613) 822-1573
Cell: (613) 858-8943
stecroix@ainleygroup.com

CAUTION: The information contained in and/or attached to this transmission is solely for the use of the intended recipient. Any copying, distribution or use by others, without the express written consent of the Ainley Group, is strictly prohibited. The recipient is responsible for confirming the accuracy and completeness of the information with the originator. Please advise the sender if you believe this message has been received by you in error.

From: Jamie Batchelor [<mailto:jamie.batchelor@rvca.ca>]
Sent: May 13, 2021 2:01 PM
To: Guy Ste-Croix <stecroix@ainleygroup.com>; Eric Lalande <eric.lalande@rvca.ca>
Subject: RE: 64 Cleopatra Drive

Hi Guy,

I'm wondering if a call may be good to go over the proposal. Are you available on Monday May 17th at 10 am for a Teams call?

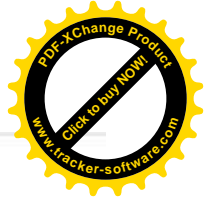

3889 Rideau Valley Drive
PO Box 599, Manotick ON K4M 1A5
T 613-692-3571 | 1-800-267-3504 F 613-692-0831 | www.rvca.ca

This message may contain information that is privileged or confidential and is intended to be for the use of the individual(s) or entity n may contain confidential or personal information which may be subject to the provisions of the Municipal *Freedom of Information & I* you are not the intended recipient of this e-mail, any use, review, revision, retransmission, distribution, dissemination, copying, printing, taking of any action in reliance upon this e-mail, is strictly prohibited. If you have received this e-mail in error, please contact the send and any copy of the e-mail and any printout thereof, immediately. Your cooperation is appreciated.

From: Guy Ste-Croix <stecroix@ainleygroup.com>
Sent: Wednesday, April 28, 2021 8:55 AM
To: Eric Lalande <eric.lalande@rvca.ca>
Cc: Jamie Batchelor <jamie.batchelor@rvca.ca>
Subject: 64 Cleopatra Drive

Hi Eric,

We are working on a building expansion at 64 Cleopatra Drive in Ottawa. The site currently has an existing two (2) storey industrial/office building and an asphalt parking lot. The existing building is to remain and shall be expanded with a proposed one (1) storey addition of approximately 4,200sq.ft. The existing asphalt parking lot (i.e. along the east and south sides of the existing building) will be reconfigured; therefore, increasing the landscaped area which in return reduces the imperviousness of the site. The north side of the existing building (i.e. gravel parking lot / storage area), will be removed to accommodate the new building addition. The overall site has an area of 0.28ha, however only 0.066ha is being redeveloped. The redeveloped portion of the site will be controlled to the 5-year pre-development level. Since the proposed redeveloped area is primarily building (which typically doesn't require storm water quality treatment) and that the existing industrial subdivision drains to an existing stormwater management pond/facility, we note that it's our interpretation that no stormwater quality requirements will be required for this site. That being said, with regards to water quality control, the City of Ottawa has requested: "Please confirm what the Rideau Valley Conservation Authority (RVCA) has identified as the quality control criteria for this site." We ask that you please confirm by email so we can include RVCA correspondence in our report as requested by the City.

Regards,

Guy Ste-Croix, LEL, C.E.T., PMP
Branch Manager



Ainley Graham & Associates Limited
2724 Fenton Road
Ottawa, Ontario, K1T 3T7
Tel: (613) 822-1052 ext. 225
Fax: (613) 822-1573
Cell: (613) 858-8943
stecroix@ainleygroup.com

CAUTION: The information contained in and/or attached to this transmission is solely for the use of the intended recipient. Any copying, distribution or use by others, without the express written consent of the Ainley Group, is strictly prohibited. The recipient is responsible for confirming the accuracy and completeness of the information with the originator. Please advise the sender if you believe this message has been received by you in error.

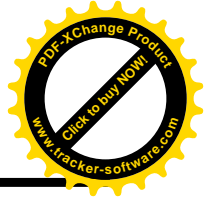
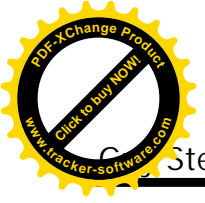

Ste-Croix

From: Kuruvilla, Santhosh <Santhosh.Kuruvilla@ottawa.ca>
Sent: May 27, 2021 1:12 PM
To: Guy Ste-Croix
Subject: RE: D07-12-16-0029 - 64 Cleopatra Drive
Attachments: FW: 64 Cleopatra Drive, D07-12-16-0029, Zoning-IG, - Construction of an additional building to an existing site

Hi Guy,

You will have to apply for an Industrial ECA and it will be a direct submission. Please see attached email for the reason.

Thanks,

Santhosh

From: Kuruvilla, Santhosh
Sent: May 14, 2021 12:26 PM
To: Guy Ste-Croix <stecroix@ainleygroup.com>
Subject: RE: D07-12-16-0029 - 64 Cleopatra Drive

Hi Guy,

I forwarded your information to our senior engineer and she requested the following additional information from you.

Hi Santhosh,

Please ask the applicant to answer each of these questions. Charles will send the request to Aziz once this is provided.

- 1) Applicants name and address:
- 2) The site name and location:
- 3) Who will own the sewer works:
- 4) Description of the proposed sewage works:
- 5) Confirmation that outside of the fact the proposed sewage works will remain privately owned, the works meet all the requirements of items 1) and 2) of schedule A of the City's ToR agreement:

Thanks,

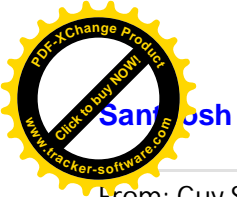

From: Guy Ste-Croix <stecroix@ainleygroup.com>
Sent: May 13, 2021 2:25 PM
To: Kuruvilla, Santhosh <Santhosh.Kuruvilla@ottawa.ca>
Subject: D07-12-16-0029 - 64 Cleopatra Drive

CAUTION: This email originated from an External Sender. Please do not click links or open attachments unless you recognize the source.

ATTENTION : Ce courriel provient d'un expéditeur externe. Ne cliquez sur aucun lien et n'ouvrez pas de pièce jointe, excepté si vous connaissez l'expéditeur.

Hi Santhosh,

Further to our discussion re. an ECA possibly not being required for the building expansion project at 64 Cleopatra Drive within the City of Ottawa, we provide the following description of what the building will be used for: **The building will be operated by a Civil contractor and will be used for storage space (with a small amount of office space) and garage for heavy Civil equipment.** We note that the redeveloped area is primarily roof which typically doesn't require stormwater quality treatment. Also, the building will not have a storm sewer connection. The building (Area A1 – see below) will be directed to the ditch storage area via eavestroughing. A catchbasin with an inlet control device will be installed in the grassed / ditched area to control post-development flows to pre-development levels. Therefore, it appears (based on our interpretation) that the expected stormwater effluent from the proposed building expansion area is non-industrial.

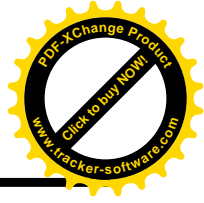
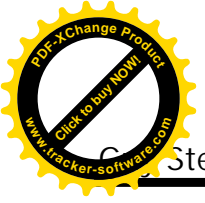

Ste-Croix

From: Primeau, Charlie (MECP) <Charlie.Primeau@ontario.ca>
Sent: June 5, 2019 7:07 AM
To: Paul Le Blanc
Cc: Guy Ste-Croix
Subject: RE: D07-12-16-0029 64 Cleopatra Drive - 170 Cleopatra Pond ECA

Good morning Paul,

Thanks for providing a copy of the SWM facility. That old CofA is pretty simple with no final effluent monitoring.

Based on my review, an ECA would be required for the above noted development.

Let me know if you required any further assistance.

Charlie Primeau
Water Compliance Supervisor
Ottawa District Office and Cornwall Area Office
Ministry of the Environment, Conservation and Parks
2430 Don Reid Drive, Ottawa ON K1H 1E1
Tel: (613) 521 3450 or 1 800 860-2195
Cell: (613) 277-3727

From: Paul Le Blanc <leblanc@ainleygroup.com>
Sent: June 4, 2019 4:13 PM
To: Primeau, Charlie (MECP) <Charlie.Primeau@ontario.ca>
Cc: Guy Ste-Croix <stecroix@ainleygroup.com>
Subject: FW: D07-12-16-0029 64 Cleopatra Drive - 170 Cleopatra Pond ECA

Hi Charlie;

Thanks for your call this past Friday; I appreciate the assistance in keeping this project moving.

I've attached the existing C of A for the downstream storm water pond received from the City of Ottawa; please let me know if this is sufficient for the purpose of identifying the pond and any associated requirements regarding our project. The address is also in the attached email.

I've also confirmed that the building is operated by a civil contractor, and that it will be used for storage space and garage for heavy equipment.

As discussed, I'm also clarifying that the receiving storm water on-site storage area will only be receiving water from the proposed roof and the grass area adjacent to the proposed addition.

Please let me know if you require anything further to complete our pre-consultation meeting.

Cheers,

Paul Le Blanc, EIT
Engineering Intern



Ainley Graham & Associates Limited
2724 Fenton Road
Ottawa, Ontario, K1T 3T7
Tel: (613) 822-1052 ext. 229
Fax: (613) 822-1573
Cell: (613) 222-4346
leblanc@ainleygroup.com

CAUTION: The information contained in and/or attached to this transmission is solely for the use of the intended recipient. Any copying, distribution or use by others, without the express written consent of the Ainley Group, is strictly prohibited. The recipient is responsible for confirming the accuracy and completeness of the information with the originator. Please advise the sender if you believe this message has been received by you in error.

From: Armstrong, Justin [<mailto:justin.armstrong@ottawa.ca>]
Sent: June-04-19 4:01 PM
To: 'Paul Le Blanc'
Subject: D07-12-16-0029 64 Cleopatra Drive - 170 Cleopatra Pond ECA

Hi Paul,

See attached for the C of A we have on file for the storm pond at 170 Cleopatra.

Regards,

Justin Armstrong, E.I.T.

Engineering Intern
Planning, Infrastructure and Economic Development Department - Services de la planification, de l'infrastructure et du développement économique
Development Review - West Branch
City of Ottawa | Ville d'Ottawa
110 Laurier Avenue West Ottawa, ON | 110, avenue. Laurier Ouest. Ottawa (Ontario) K1P 1J1
613.580.2400 ext./poste 21746, justin.armstrong@ottawa.ca

This e-mail originates from the City of Ottawa e-mail system. Any distribution, use or copying of this e-mail or the information it contains by other than the intended recipient(s) is unauthorized. Thank you.

Le présent courriel a été expédié par le système de courriels de la Ville d'Ottawa. Toute distribution, utilisation ou reproduction du courriel ou des renseignements qui s'y trouvent par une personne autre que son destinataire prévu est interdite. Je vous remercie de votre collaboration.



Ontario

Ministry of the Environment

463.21
DWS4
BER

Certificate No. 3-1153-82-836

RECEIVED

LOT-03-COFA (Vol. 1)

JAN 20 1983

(SWF-1127)

GORE & STORRIE LTD.
OTTAWA

Certificate of Approval (Sewage)

Whereas CITY OF NEPEAN

XX

has applied in accordance with Section 24 of the Ontario Water Resources Act for approval of:-

Stormwater retention pond to be constructed in the Merivale Area (Lot 27, Concession 1) of the City of Nepean consisting of a fenced impoundment with a total surface area and effective storage volume of approximately 1.0 ha and 1.3 ha - m respectively at the 85.366 m water elevation; including outlet control structure with 200 mm diameter orifice and high level overflow weir at elevation 85.366 m, and inlet sewer and inlet structure; all in accordance with the plans and specifications prepared by Gore and Storrie Limited, Consulting Engineers, at a total estimated cost, including engineering and contingencies, of ONE MILLION ONE HUNDRED FIFTY EIGHT THOUSAND DOLLARS (\$1,158,000.00).

THIS IS A TRUE COPY OF THE ORIGINAL CERTIFICATE MAILED

ON Jan 17/83
an
(SIGNED)

Now therefore this is to certify that after due enquiry the said proposed works have been approved under Section 24 of the Ontario Water Resources Act.

DATED AT TORONTO this 13th day of January 19 83

- Attn:-Mr. D.E. Hobbs, Clerk, City of Nepean
- cc:-Mr. A.C. Bellinger, Comm. of Works
- Mr. R.E. Moore, MOE SE, Reg. Dir.
- Gore and Storrie Limited
- Attn:-Mr. D.W. Smith, P. Eng.

[Signature]
Director



VHV Vertical Vortex Flow Regulator

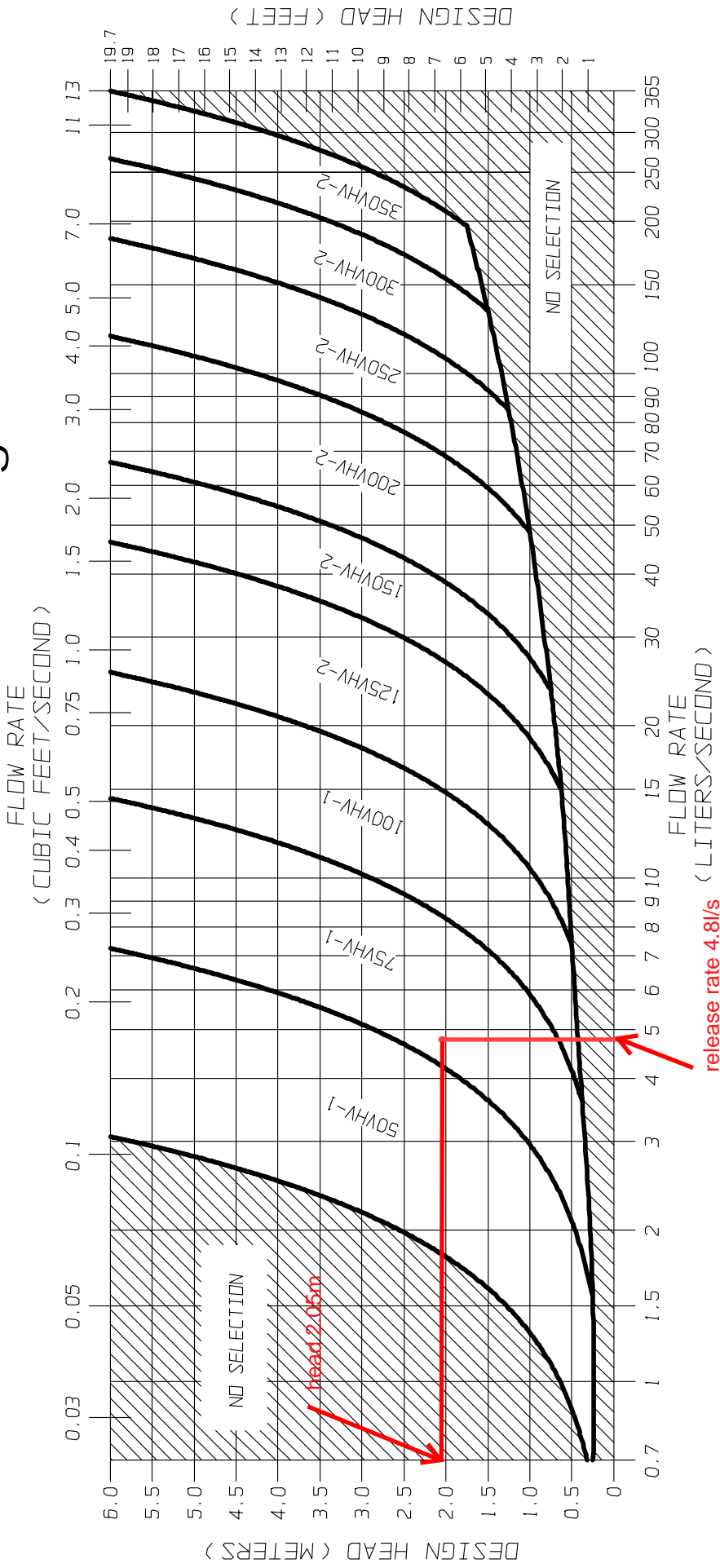

FIGURE 3 - VHV

JOHN MEUNIER

AINLEY Project: 19028-1

Location: 64 Cleopatra Drive

Proposed Detention Area (Pond) Volume Calculations







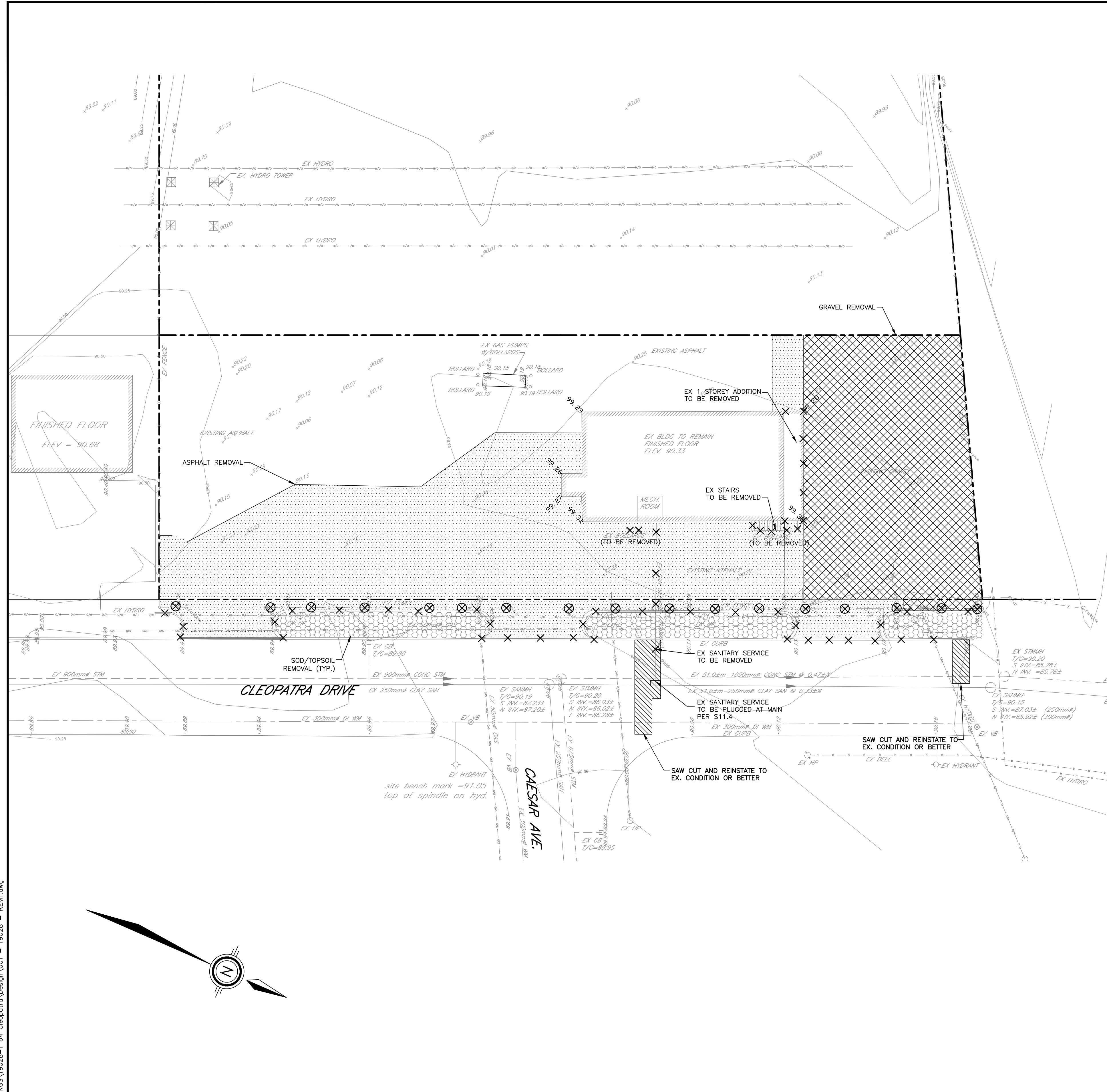
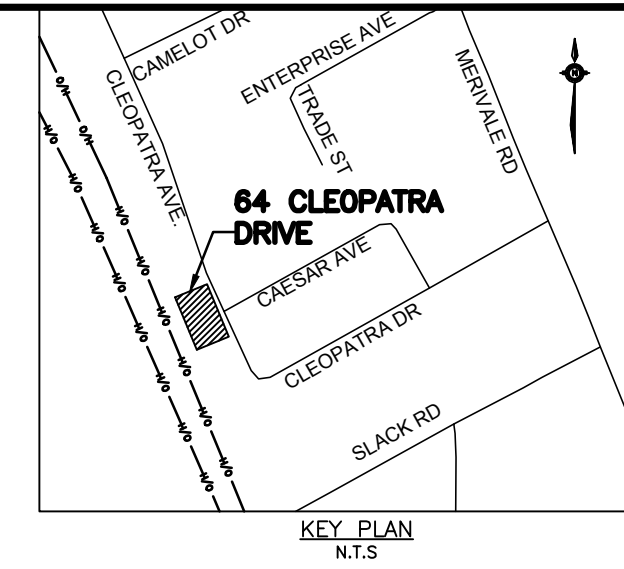





Pond #	Length	Average top width	Average bottom width	Side slope	Upstream depth	Downstream depth	Average Depth	Section area	Volume
	m	m	m		m	m	m	sq.m	cu.m
A1	24.50	2.23	0.00	2.00	0.12	0.57	0.35	0.38	9.42

APPENDIX D

- Removal and Adjustment (Dwg. 001-19028-REM1)
- Storm Drainage Area Plan (Dwg. 002-19028-STM1)
- Site Servicing and Grading Plan (Dwg. 003-19028-SG1)
- Erosion and Sediment Control Plan (Dwg. 004-19028-SC1)

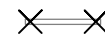

REMOVALS

-  ASPHALT REMOVAL (ROAD, DRIVEWAYS, PARKING AREAS)
-  ASPHALT SIDEWALK REMOVAL
-  GRAVEL DRIVEWAY REMOVAL
-  CONCRETE SIDEWALK REMOVAL
-  TOPSOIL REMOVAL
-  REMOVE MANHOLE, CATCHBASIN, VALVE, HYDRANT, ETC.
-  REMOVE LS, BOLLARD & CONCRETE BASE
-  ADJUST MANHOLE
-  REMOVE EXISTING STORM SEWER
-  REMOVE EXISTING SANITARY SEWER
-  REMOVE EXISTING WATERMAIN
-  REMOVE EXISTING FENCE
-  REMOVE EXISTING CONCRETE CURB
-  REMOVE SIGN

NOTES- REMOVALS
 LOCATE EXISTING WELL SERVICING EXISTING BUILDING AND DECOMMISSION. DECOMMISSIONING MUST BE DONE BY A LICENSED WELL CONTRACTOR IN ACCORDANCE WITH WELLS REGULATION (R.R.O 1990 REGULATION 903) AS PER ONTARIO WATER RESOURCE ACT.

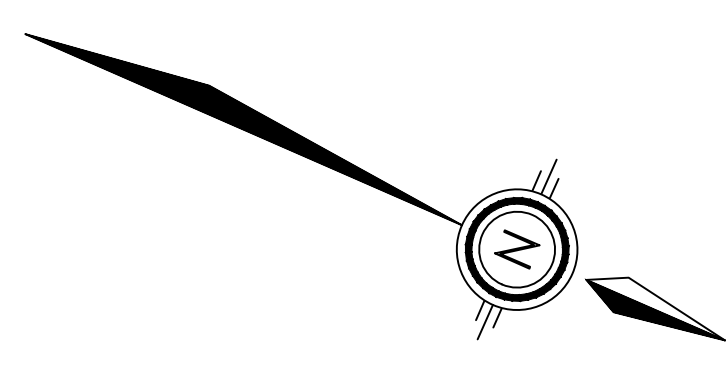

Jun 02, 2021 I:\DRAWINGS\19028-1 64 Cleopatra\Design\001 - REM1.dwg

NOTES

OWNER:
 2336925 ONTARIO INC.
 64 CLEOPATRA DRIVE
 OTTAWA, ONTARIO
 K2G 0B4

CONTRACT DRAWINGS:
 Contractor must verify all dimensions and be responsible for same. Any discrepancies must be reported to the Engineer before commencing work. Drawings are not to be scaled. Drawings may not be used for any purpose other than that stipulated in the contract agreement between the owner/client and the Engineer without the express written consent of Anley Graham & Associates Limited. Use of these drawings by any party for any other purpose is subject to the following caution.

CAUTION: The information contained in this drawing is solely for the intended recipient. Any copying, distribution or use by others without the express written consent of Anley Graham & Associates Limited is prohibited. The recipient is responsible for confirming the accuracy and completeness of the information with the originator. The recipient assumes all risks and liabilities associated with the use of the drawings. The recipient will save and hold harmless Anley Graham & Associates Limited for any claims whatsoever associated with or related to the use of the drawings. The recipient will not reuse any portion of the drawings for any future project without the express written permission of Anley Graham & Associates Limited.

NO.	REVISIONS	DATE	INITIAL
3	RE-ISSUED FOR SITE PLAN APPROVAL	JUNE 07/21	JX
2	RE-ISSUED FOR SITE PLAN APPROVAL	JUNE 19/20	JX
1	ISSUED FOR SITE PLAN APPROVAL	MAY 24/19	GSC

Not Valid Unless Signed And Dated

Professional Engineers
 Ontario
 June 07, 2021
Limited Licensee
 Name: J.W.XU
 Number: 100171806
 Category: CIVIL see limitation
 Limitations:
 This licence is subject to the limitations as detailed on the certificate.
 Association of Professional Engineers of Ontario

SCALE: 1 : 250
 DESIGN: JX
 DRAWN: MH
 CHECKED: GSC
 DATE: MAY 2019

BUILDING ADDITION
 64 CLEOPATRA DRIVE
 CITY OF OTTAWA

REMOVALS AND ADJUSTMENTS



CONTRACT No. 19028 001-19028-REM1

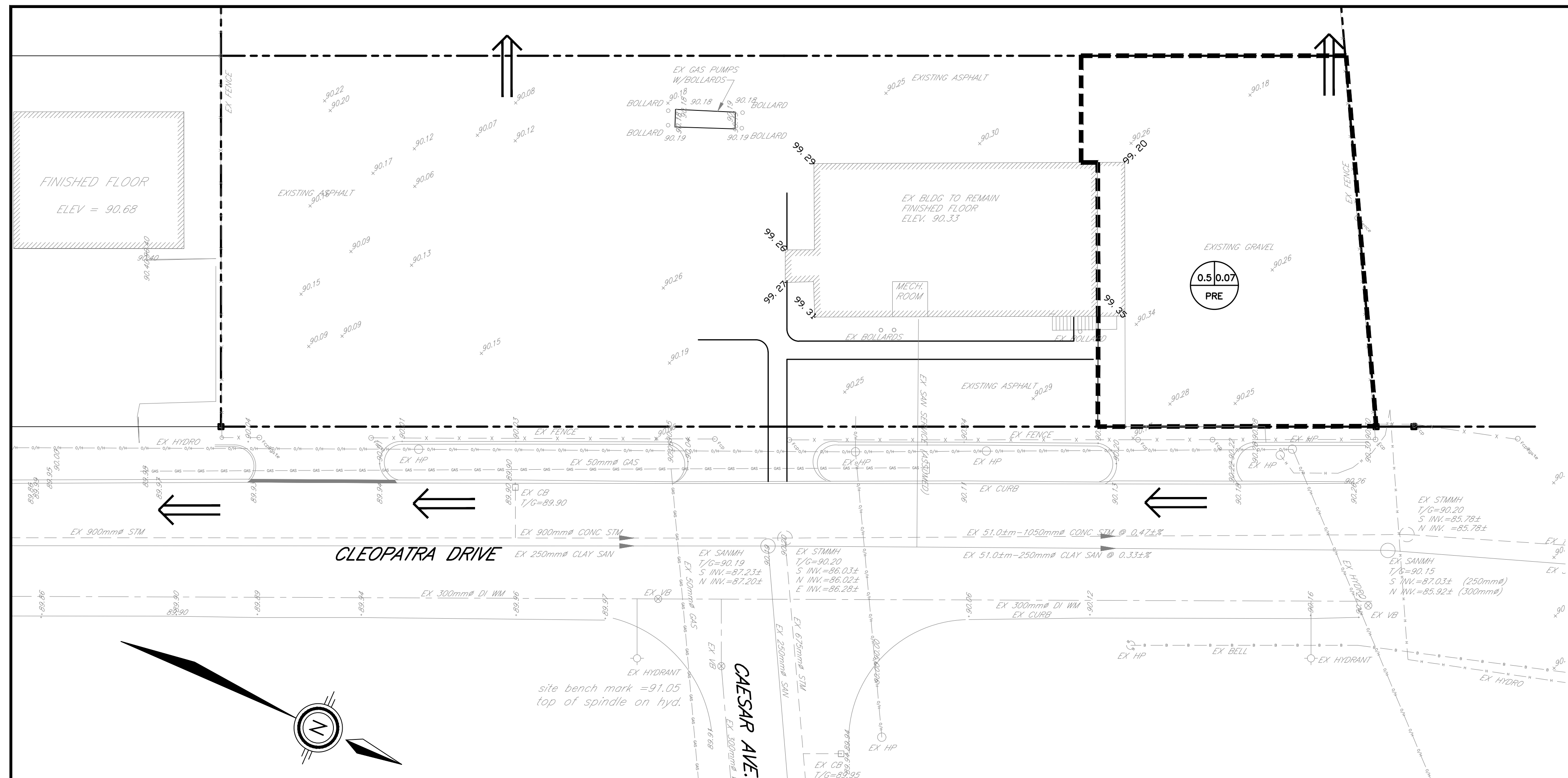

EXISTING STORM DRAINAGE AREA PLAN

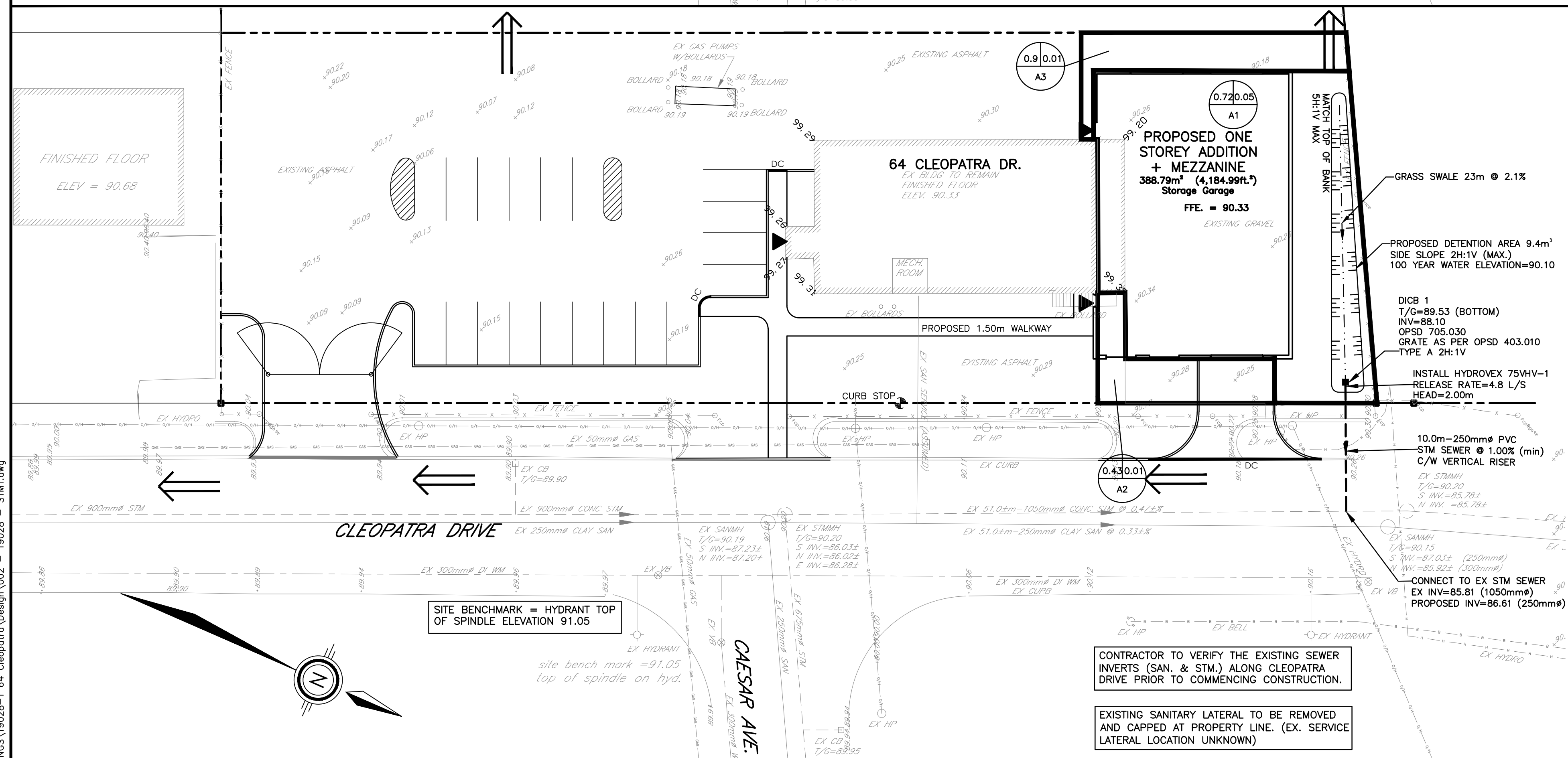
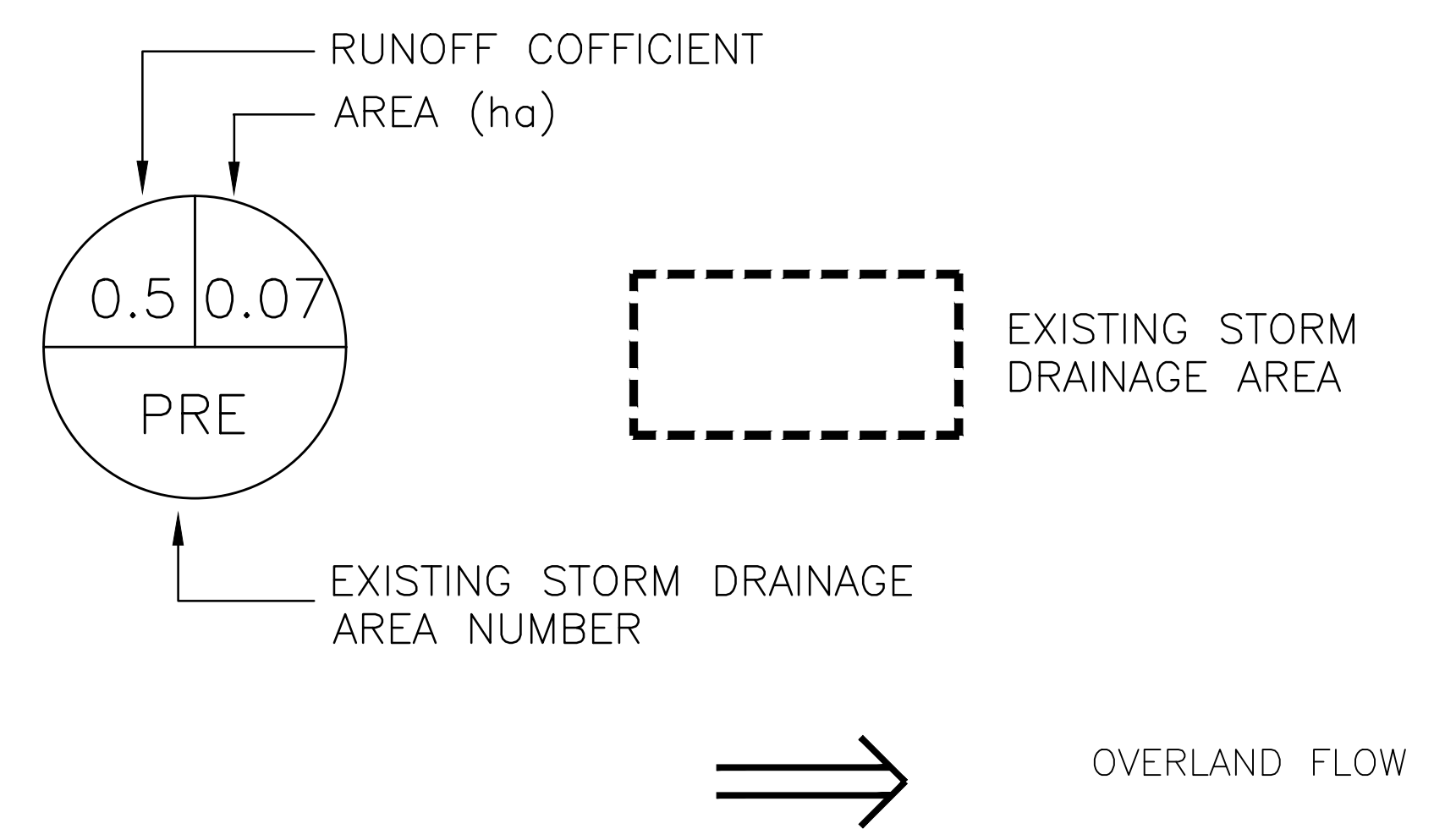

PROPOSED STORM DRAINAGE AREA PLAN

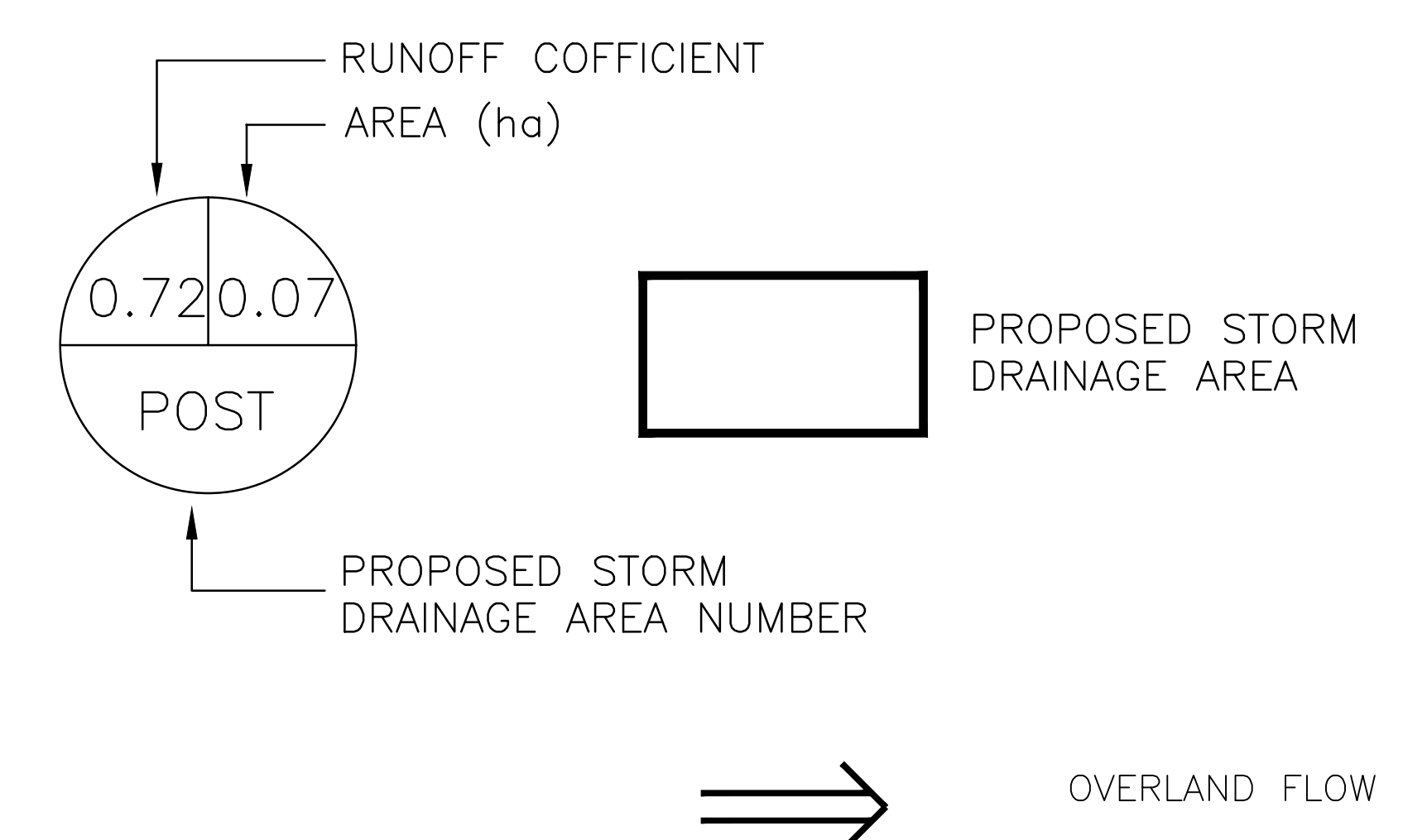

NOTES

CONTRACTOR TO VERIFY THE EXISTING SEWER INVERTS (SAN. & STM.) ALONG CLEOPATRA DRIVE PRIOR TO COMMENCING CONSTRUCTION.

EXISTING SANITARY LATERAL TO BE REMOVED AND CAPPED AT PROPERTY LINE. (EX. SERVICE LATERAL LOCATION UNKNOWN)

NO.	REVISIONS	DATE	INITIAL
3	RE-ISSUED FOR SITE PLAN APPROVAL	JUNE 07/21	JX
2	RE-ISSUED FOR SITE PLAN APPROVAL	JUNE 19/20	JX
1	ISSUED FOR SITE PLAN APPROVAL	APR 26/19	GSC

Not Valid Unless Signed And Dated

Professional Engineers Ontario
 June 07, 2021
 Limited Licensee
 Name: JWX
 Number: 100171806
 Category: CIVIL see limitation
 Limitations:
 This license is subject to the limitations as detailed on the certificate.
 Association of Professional Engineers of Ontario

SCALE: 1 : 250
 DESIGN: JX
 DRAWN: MH
 CHECKED: GSC
 DATE: APRIL 2019

CITY OF OTTAWA
 64 CLEOPATRA DRIVE
 STORM DRAINAGE AREA PLAN

CONTRACT No. 19028 002-19028-STM1

SEWER CROSSING TABLE

LOCATION	EX 50mm# GAS	EX 1050mm# STORM SEWER	EX 250mm# SANITARY SEWER	PROPOSED 50mm# COPPER WM	PROPOSED 150mm# SAN LATERAL
X-1	INV=89.28±			OBV=87.85±	
X-2		(NV=85.98±) OBV=87.03±		INV=87.75±	
X-3			(NV=87.16±) OBV=87.41±	INV=87.75±	
X-4	INV=89.28±				(NV=87.69±) OBV=87.84±
X-5		(NV=85.97±) OBV=87.02±			INV=87.63±

LEGEND

	PROPERTY LINE		PLANNED CATCHBASIN C/W 5m LONG (MIN.) SUBDRAIN IN FOUR ORTHOGONAL DIRECTIONS (CB1, CB2, CB 3 & CB4)
	EXISTING SANITARY SEWER		PLANNED CATCHBASIN ADJACENT TO CURB C/W 5m LONG (MIN.) SUBDRAIN IN LONGITUDINAL DIRECTIONS (CB 5)
	EXISTING WATERMAIN		PLANNED WATERMAIN
	EXISTING STORM SEWER		PLANNED V&VB
	EXISTING FENCE		PLANNED 100mm# WEEPING TILE
	EXISTING UTILITY POLE		PLANNED LIGHT FIXTURE
	EXISTING CATCHBASIN		ROOF DRAIN
	EXISTING GAS		REMOTE WATER METER
	EXISTING UNDERGROUND HYDRO		WATER METER
	EXISTING UNDERGROUND BELL LINE		OVERLAND FLOW ROUTE
	PLANNED STORM SEWER		
	PLANNED SANITARY SEWER		

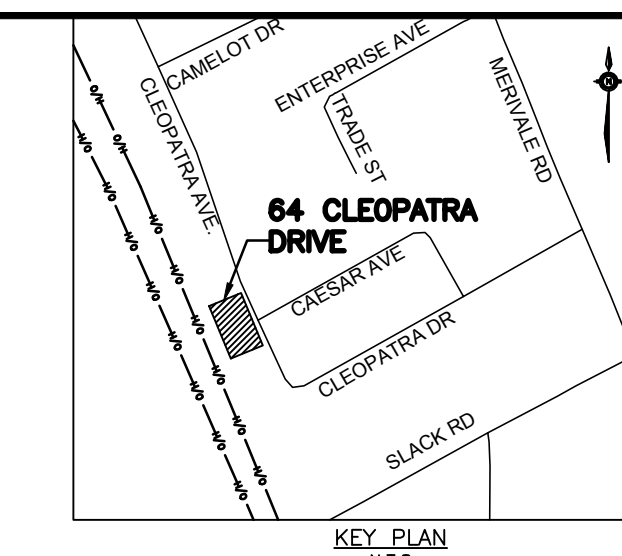

- NOTES: GENERAL**
- CONTRACTOR TO VERIFY ALL BUILDING AND SITE LAYOUT DIMENSIONS WITH THE ARCHITECT'S LATEST DRAWINGS PRIOR TO COMMENCEMENT OF CONSTRUCTION LAYOUT. ALL CONSTRUCTION LAYOUT SHALL BE CONFIRMED BY THE ARCHITECT PRIOR TO CONSTRUCTION.
 - ALL ELEVATIONS ARE SHOWN AS METRIC AND GEODETIC.
 - CONSTRUCTION LAYOUT SHALL BE DONE BY THE CONTRACTOR.
 - CONTRACTOR IS RESPONSIBLE FOR THE PROTECTION OF ANY EXISTING SERVICES AND FACILITIES THAT MAY BE DAMAGED DURING CONSTRUCTION. CONTRACTOR TO LOCATE ALL EXISTING UNDERGROUND SERVICES PRIOR TO ANY EXCAVATION.
 - CONTRACTOR IS RESPONSIBLE FOR THE REPAIR AND/OR REPLACEMENT OF ANY DAMAGED UNDERGROUND UTILITIES, SEWERS OR SERVICES AT NO ADDITIONAL COST TO THE OWNER. ALL FEES, INSPECTION, PERMITS AND COORDINATION WILL BE AT THE CONTRACTOR'S EXPENSE.
 - CONTRACTOR TO VERIFY ALL SURFACE AND SUBSURFACE CONDITIONS PRIOR TO CONSTRUCTION BY REVIEWING THE GEOTECHNICAL REPORT. IF A GEOTECHNICAL REPORT IS NOT AVAILABLE, THE CONTRACTOR IS RESPONSIBLE TO MAKE THEIR OWN INDEPENDENT ASSESSMENT OF THE SUBSURFACE CONDITIONS BY WHATEVER MEANS POSSIBLE, AT NO ADDITIONAL COST TO THE OWNER. THE CONTRACTOR SHALL NOT MAKE ANY CLAIMS FOR ADDITIONAL COMPENSATION AS A RESULT OF UNSUITABLE CONDITIONS.
 - CONTRACTOR TO COORDINATE ALL PERMITS, FEES, INSPECTIONS AND APPROVALS AS REQUIRED BY THE CITY, AT NO ADDITIONAL COST TO THE OWNER.
 - CONTRACTOR IS RESPONSIBLE FOR ALL DEWATERING, SUPPORT AND PROTECTION OF EXCAVATIONS. DISCHARGE OF WATER SHALL BE IN AN APPROVED MANNER AND CONSISTENT WITH THE MINISTRY OF THE ENVIRONMENT AND THE CITY OF OTTAWA.
 - ANY AND ALL CHANGES MUST BE APPROVED IN WRITING FROM THE ENGINEER PRIOR TO IMPLEMENTATION.
 - ALL UNSUITABLE OR EXCESS MATERIAL SHALL BE REMOVED, HAULED AND DUMPED AT A LOCATION APPROVED BY THE OWNER. THIS WORK WILL BE COMPLETED AT NO ADDITIONAL COST TO THE CONTRACTOR.
 - ALL DISTURBED AREAS SHALL BE REINSTATED TO EQUAL OR BETTER CONDITION TO THE SATISFACTION OF THE ENGINEER AND THE CITY OF OTTAWA.
 - ASPHALT WEAR COURSE SHALL NOT BE PLACED UNTIL FINAL VIDEO INSPECTION OF THE SEWERS HAVE BEEN COMPLETED AND APPROVED BY THE ENGINEER AND/OR CITY.
 - ALL UNSUITABLE MATERIAL SHALL BE EXCAVATED AND BACKFILLED WITH GRANULAR 'B'. COMPACTION TO CONFORM WITH CITY STANDARDS.
 - CITY OF OTTAWA STANDARD CONSTRUCTION & MATERIAL SPECIFICATIONS, THE ONTARIO PROVINCIAL STANDARD DRAWINGS (OPSD) AND THE ONTARIO PROVINCIAL STANDARD SPECIFICATIONS (OPSS), ALONG WITH THESE DRAWINGS SHALL FORM PART OF THE CONTRACT DOCUMENTS AND SHALL APPLY TO ALL CONSTRUCTION ACTIVITIES.
 - THE CONTRACTOR IS RESPONSIBLE FOR THE INSTALLATION AND CONSTRUCTION OF ALL SEDIMENT AND EROSION CONTROL MEASURES TO ENSURE THAT SEDIMENT DOES NOT MIGRATE FROM THE CONSTRUCTION SITE. SEDIMENTS SHALL BE CONTAINED AND DISPOSED OF IN A MANNER CONSISTENT WITH THE CITY OF OTTAWA SPECIFICATIONS.
 - THE CONTRACTOR SHALL VERIFY ALL SURFACE AND SUBSURFACE CONDITIONS PRIOR TO COMMENCING CONSTRUCTION BY REVIEWING THE GEOTECHNICAL INVESTIGATION REPORT PCS498-LET.01 PREPARED BY PATERSON GROUP, DATED FEBRUARY 12, 2016.
 - ALL ASPHALT REMOVAL AREAS SHALL BE SAW CUT TO FORM A CLEAN STRAIGHT EDGE PRIOR TO PLACEMENT OF NEW ASPHALT.
 - CONTRACTOR TO PROVIDE 'AS-BUILT' INFORMATION (SEWER INVERTS, SERVICE LATERAL INVERTS & LOCATION, ASPHALT & TOP OF CURB GRADES, ETC.) TO THE ENGINEER IN A FORMAT CONSISTENT WITH CITY STANDARDS.
 - CURBS SHALL CONFORM TO CITY OF OTTAWA STD. SC1.1 (BARRIER CURB).
 - ALL EXISTING PAVEMENT, CURBS, SIDEWALKS, DRIVEWAYS AND BOULEVARD AREAS DISTURBED BY THE CONSTRUCTION MUST BE REINSTATED TO EXISTING CONDITION OR BETTER.
- NOTES: SERVICE LATERALS**
- THE FOUNDATION DRAIN OF THE PROPOSED ONE STOREY ADDITION IS TO BE CONNECTED TO THE EXISTING BUILDING FOUNDATION DRAIN (IF APPLICABLE).
 - DIRECT ROOF LEADER CONNECTIONS TO THE STORM SEWER SYSTEM WILL NOT BE PERMITTED. ROOF LEADERS SHALL DISCHARGE TO THE SURFACE.
 - CONNECTION OF FOUNDATION DRAINS TO THE SANITARY SEWER IS NOT PERMITTED.
 - SANITARY SEWER LATERALS SHALL BE CONSTRUCTED AT A GRADIENT OF AT LEAST 1.00%.
 - SANITARY SEWER LATERALS SHALL BE SDR-28 PIPE.
 - THE MINIMUM DIAMETER FOR SANITARY SEWER LATERALS IS 135mm.
 - SANITARY SEWER LATERALS SHALL HAVE A MINIMUM OF 2.0m COVER. THERMAL INSULATION IS TO BE INSTALLED WHERE REQUIRED.
 - SANITARY SEWER LATERALS SHALL BE CONSTRUCTED IN ACCORDANCE WITH CITY OF OTTAWA STANDARDS S11 AND S11.1.
 - WATER SERVICE TO BE 50mm COPPER, INSTALLED PER CITY OF OTTAWA STANDARD W33.
 - WATER SERVICE POST ASSEMBLY TO BE IN ACCORDANCE WITH STANDARD W35.
 - WATER SERVICE TO BE INSTALLED WITH A MINIMUM COVER OF 2.4m. THERMAL INSULATION IS TO BE INSTALLED WHERE REQUIRED.
 - WATER SERVICE INSTALLATION AT SEWER CROSSINGS PER STD. W38.
 - WATER SERVICE BEDDING SHALL BE CONSTRUCTED IN ACCORDANCE WITH CITY OF OTTAWA STANDARD W17.
 - INSTALLATION OF WATER METER AND REMOTE RECEPTACLE SHALL BE IN ACCORDANCE WITH CITY OF OTTAWA STANDARDS.
 - CATHODIC PROTECTION IS REQUIRED FOR ALL IRON FITTINGS IN ACCORDANCE WITH CITY OF OTTAWA STANDARDS.
 - CONNECTION TO EXISTING WATERMAIN ALONG CLEOPATRA DRIVE SHALL BE COMPLETED BY CITY FORCES. EXCAVATION, BACKFILL AND REINSTATEMENT SHALL BE COMPLETED BY THE CONTRACTOR.
 - PROVIDE FOUNDATION DRAINAGE AS PER PATERSON GROUP GEOTECHNICAL REPORT PCS498-LET.01 DATED FEBRUARY 12, 2016 AND CONNECT TO EXISTING FOUNDATION DRAINAGE IF PRESENT.

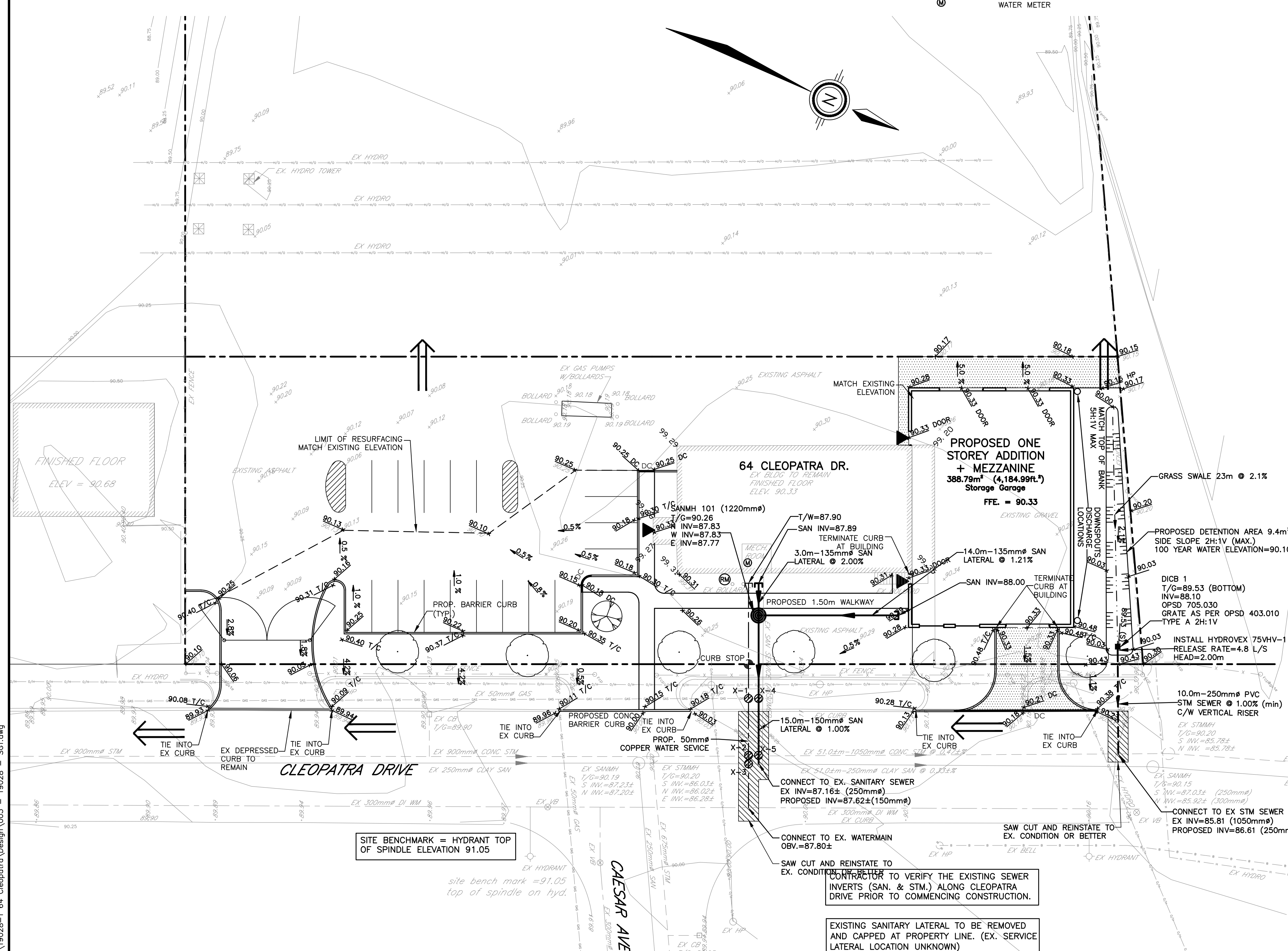

RECOMMENDED PAVEMENT DESIGN:

- 40mm HL3
- 50mm HL8
- 150mm OPSS GRANULAR 'A'
- 450mm OPSS GRANULAR 'B' TYPE II

<p>NOTES</p> <p>OWNER: 2336925 ONTARIO INC. 64 CLEOPATRA DRIVE OTTAWA, ONTARIO K2G 0B4</p>	<p>CONTRACT DRAWINGS: Contractor must verify all dimensions and be responsible for same. Any discrepancies must be reported to the Engineer before commencing work. Drawings are not to be scaled. Drawings may not be used for any purpose other than that stipulated in the contract agreement between the owner/client and the Engineer without the express written consent of Anley Graham & Associates Limited. Use of these drawings by any party for any other purpose is subject to the following caution. CAUTION: The information contained in this drawing is solely for the intended recipient. Any copying, distribution or use by others without the express written consent of Anley Graham & Associates Limited is prohibited. The recipient is responsible for confirming the accuracy and completeness of the information with the originator. The recipient assumes all risks and liabilities associated with the use of the drawings. The recipient will save and hold harmless Anley Graham & Associates Limited for any claims whatsoever associated with or related to the use of the drawings. The recipient will not reuse any portion of the drawings for any future project without the express written permission of Anley Graham & Associates Limited.</p>	<table border="1"> <thead> <tr> <th>NO.</th> <th>REVISIONS</th> <th>DATE</th> <th>INITIAL</th> </tr> </thead> <tbody> <tr> <td>3</td> <td>RE-ISSUED FOR SITE PLAN APPROVAL</td> <td>JUNE 07/21</td> <td>JX</td> </tr> <tr> <td>2</td> <td>RE-ISSUED FOR SITE PLAN APPROVAL</td> <td>JUNE 19/20</td> <td>JX</td> </tr> <tr> <td>1</td> <td>ISSUED FOR SITE PLAN APPROVAL</td> <td>MAY 24/19</td> <td>GSC</td> </tr> </tbody> </table>	NO.	REVISIONS	DATE	INITIAL	3	RE-ISSUED FOR SITE PLAN APPROVAL	JUNE 07/21	JX	2	RE-ISSUED FOR SITE PLAN APPROVAL	JUNE 19/20	JX	1	ISSUED FOR SITE PLAN APPROVAL	MAY 24/19	GSC	<p>Not Valid Unless Signed And Dated</p> <p>Professional Engineers Ontario June 07, 2021</p> <p>Limited Licensee Name: JWX Number: 100171806 Category: CIVIL see limitation This license is subject to the limitations as detailed on the certificate. Association of Professional Engineers of Ontario</p>	<p>SCALE: 1 : 250</p> <p>DESIGN: JX</p> <p>DRAWN: MH</p> <p>CHECKED: GSC</p> <p>DATE: MAY 2019</p>	<p>BUILDING ADDITION 64 CLEOPATRA DRIVE CITY OF OTTAWA</p> <p>SITE SERVICING AND GRADING PLAN</p>	<p>CONTRACT No. 19028 003-19028-SG1</p>
NO.	REVISIONS	DATE	INITIAL																			
3	RE-ISSUED FOR SITE PLAN APPROVAL	JUNE 07/21	JX																			
2	RE-ISSUED FOR SITE PLAN APPROVAL	JUNE 19/20	JX																			
1	ISSUED FOR SITE PLAN APPROVAL	MAY 24/19	GSC																			

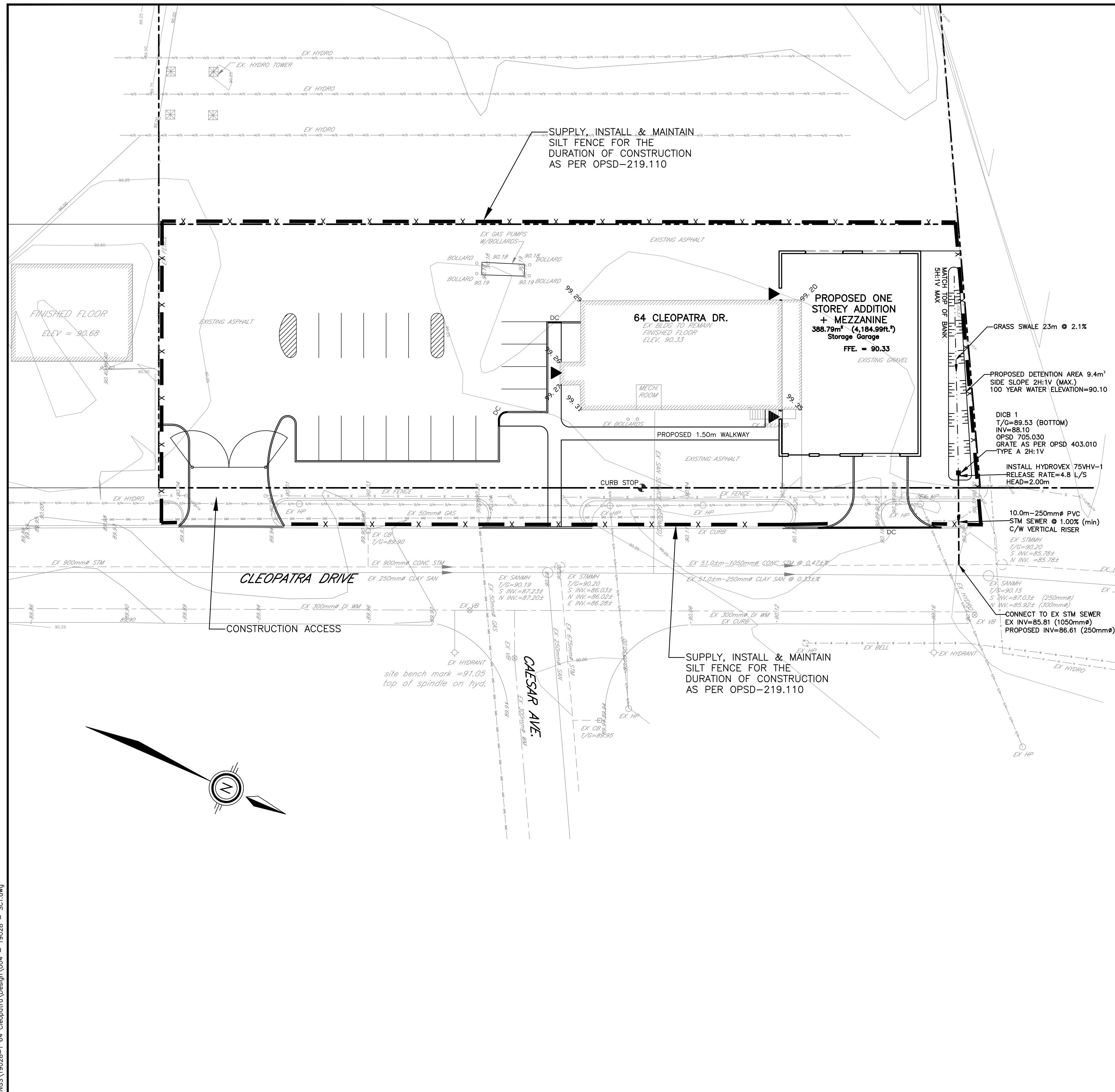
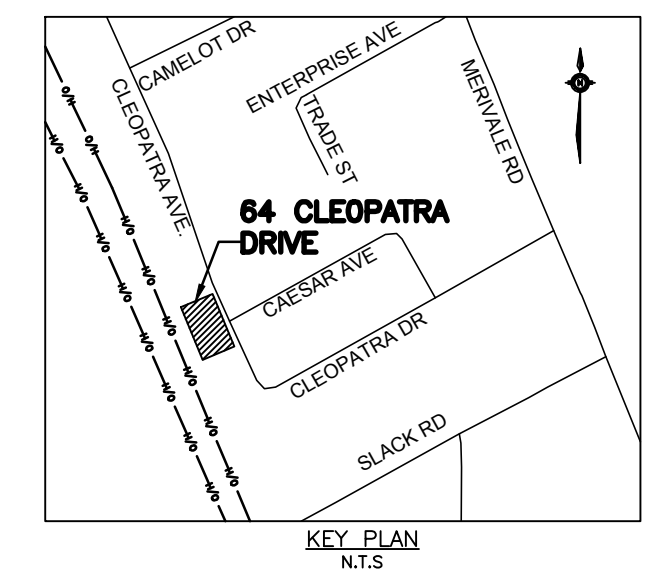

TEMPORARY EROSION & SEDIMENT CONTROL NOTES

1. A MUD MAT IS TO BE INSTALLED PRIOR TO COMMENCING CONSTRUCTION AND TO BE MAINTAINED UNTIL ALL CONSTRUCTION IS COMPLETED. MUD MAT SHOULD BE SUFFICIENT LENGTH TO ENSURE THAT A MINIMUM AMOUNT OF MATERIAL IS TRUCKED OFF SITE ONTO ADJACENT ROADS.
2. SILT FENCES SHALL BE INSTALLED AROUND THE PERIMETER OF THE SITE AND MAINTAINED UNTIL THE COMPLETION OF THE LANDSCAPE WORKS. (SEE DETAIL - OPSD 219.110)
3. CATCHBASIN SEDIMENT PROTECTION IS TO BE INSTALLED AT ALL CATCHBASIN AND CATCHBASIN MANHOLE LOCATIONS ALONG CLEOPATRA DRIVE AND ARE TO BE MAINTAINED UNTIL ALL CONSTRUCTION IS COMPLETED. (SEE DETAIL BELOW)

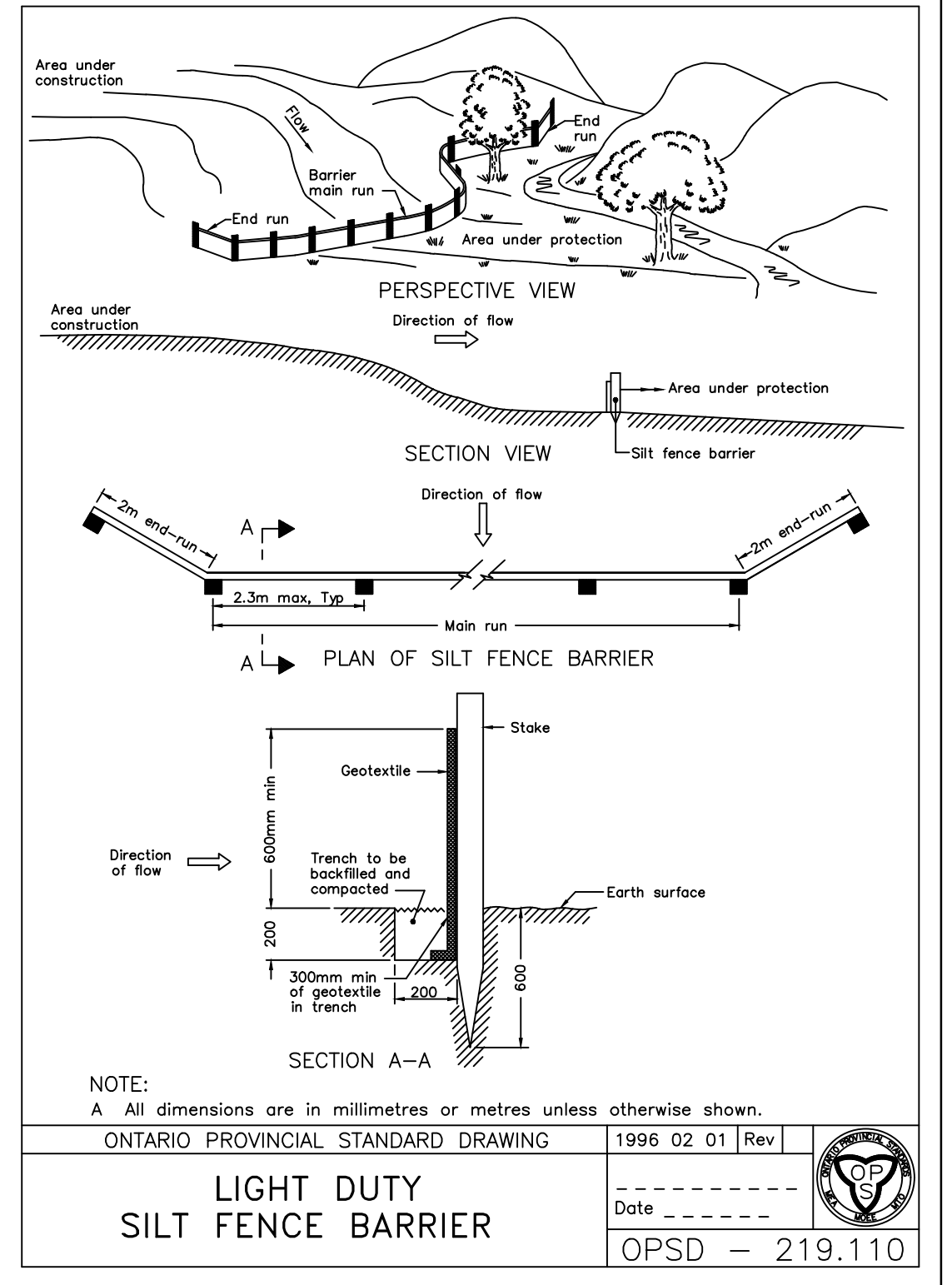
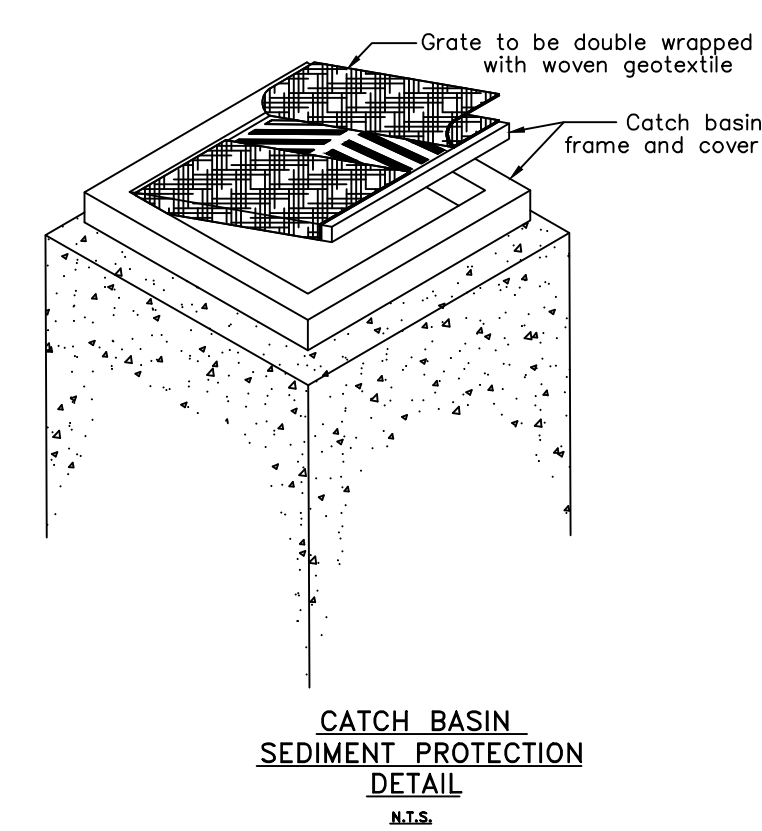

NOTE:
A All dimensions are in millimetres or metres unless otherwise shown.

ONTARIO PROVINCIAL STANDARD DRAWING 1996 02 01 Rev

LIGHT DUTY SILT FENCE BARRIER

Date _____

OPSD - 219.110

Jun 02, 2021 1:00 PM I:\DRAWINGS\19028-1-64 Cleopatra\Design\004 - 19028 - SC1.dwg

NOTES

OWNER:
2336925 ONTARIO INC.
64 CLEOPATRA DRIVE
OTTAWA, ONTARIO
K2G 0B4

CONTRACT DRAWINGS:
Contractor must verify all dimensions and be responsible for same. Any discrepancies must be reported to the Engineer before commencing work. Drawings are not to be copied, distributed or used by others without the express written consent of the Engineer. Drawings are not to be used for any purpose other than that stipulated in the contract agreement between the owner/client and the Engineer without the express written consent of Anley Graham & Associates Limited. Use of these drawings by any party for any other purpose is subject to the following caution.

CAUTION: The information contained in this drawing is solely for the intended recipient. Any copying, distribution or use by others without the express written consent of Anley Graham & Associates Limited is prohibited. The recipient is responsible for confirming the accuracy and completeness of the information with the originator. The recipient assumes all risks and liabilities associated with the use of the drawings. The recipient will save and hold harmless Anley Graham & Associates Limited for any claims whatsoever associated with or related to the use of the drawings. The recipient will not reuse any portion of the drawings for any future project without the express written permission of Anley Graham & Associates Limited.

NO.	REVISIONS	DATE	INITIAL
3	RE-ISSUED FOR SITE PLAN APPROVAL	JUNE 07/21	JX
2	RE-ISSUED FOR SITE PLAN APPROVAL	JUNE 19/20	JX
1	ISSUED FOR SITE PLAN APPROVAL	MAY 24/19	GSC

Not Valid Unless Signed And Dated

Professional Engineers
Ontario
JUNE 07, 2021
Limited Licensee
Name: JWXU
Number: 100171806
Category: CIVIL; see limitation
Limitations:
This licence is subject to the limitations as detailed on the certificate.
Association of Professional Engineers of Ontario

SCALE: 1 : 250
DESIGN: JX
DRAWN: MH
CHECKED: GSC
DATE: MAY 2019

**BUILDING ADDITION
64 CLEOPATRA DRIVE
CITY OF OTTAWA**

EROSION AND SEDIMENT CONTROL PLAN

CONTRACT No. 19028 004-19028-SC1