



Functional Servicing and Stormwater Management Report - *Circle K*

Type of Document:

Site Plan Approval Application - City of Ottawa File No.: PC2018-0342

Project Name:

Circle K Nepean
1545 Woodroffe Avenue, City of Ottawa

Project Number:

BRM-00606364-B0

Prepared and Reviewed By:

Jordan Stern, P.Eng.
Project Engineer, Central Ontario

William Grandy, P.Eng.
Practice Lead, Water Resources, Central Ontario

Approved By:

Crystal Frazao
Project Manager

EXP

1595 Clark Boulevard
Brampton, ON L6T 4V1
t: +1.905.793.9800
f: +1.905.793.0641

Date Submitted:

2021-04-22 Issued for Client Review
2021-04-27 Issued for Site Plan Application
2021-09-24 Re-issued for Site Plan Application

Table of Contents

- 1. Introduction 2
 - 1.1. Existing Site Information 2
 - 1.2. Proposed Development 3
- 2. Sanitary Servicing..... 5
 - 2.1. Sanitary Sewer System 5
 - 2.2. Sanitary Service Connection..... 5
 - 2.3. Recommendations 5
- 3. Water Distribution 6
 - 3.1. Proposed Water Servicing System 6
 - 3.2. Recommendations 6
- 4. Stormwater Management Analysis 7
 - 5.1. Allowable Release Rate 7
 - 5.2. Stormwater Quantity Management..... 7
 - 5.3. Stormwater Quality Management 10
 - 5.4. Storm Conveyance 10
 - 5.5. Erosion Control..... 11
 - 5.6. Water Balance..... 11
- 5. Utilities..... 12
- 6. Conclusions 13

- Appendix A – Site Servicing and Grading Plans
- Appendix B – Firefighting Water Design Calculations
- Appendix C – Stormwater Management Design Calculations
- Appendix D – Sanitary Design Calculations

1. Introduction

EXP has been retained by Circle K to complete the Civil Engineering design for the development of a gas station and convenience store site in the City of Ottawa, at 1545 Woodroffe Avenue. This report will review the requirements for site servicing, grading and stormwater management for the proposed development. The location and aerial view of the site is shown in Figures 1 and 2.

1.1. Existing Site Information

The existing site is located at the at the northeast corner of Woodroffe Avenue and Medhurst Drive intersection in the City of Ottawa. Currently, the site is occupied by an existing ESSO gas station, car wash and convenience store, as well as an abandoned Tim Hortons location. The site is generally flat with sloping towards the existing catchbasins on the site. Externally, the site frontage slopes down slightly along Woodroffe Avenue towards the north. The site is abutted by residential areas to the north and east.



Figure 1 - Existing Site



Figure 2 - Existing Aerial

1.2. Proposed Development

The proposed Circle K site is approximately 0.82 Ha (8,210 m²) in area and will be comprised of a Convenience Store/Retail Building, a Car Wash Building, and Fueling Area, as well as parking and landscaped areas. The proposed development is indicated in Figure 3 and details are summarized in Table 1.

Table 1 - Proposed Site Information

Location	Building	Site Area (m2)
A	C-Store, Car Wash (Building Areas)	646
B	Fueling Canopy	354
C	Landscape Open Space	1820
Remaining Site	Parking, Drive Aisles, Pedestrian Walkways and Loading Areas	5390
Total Site Area		8210

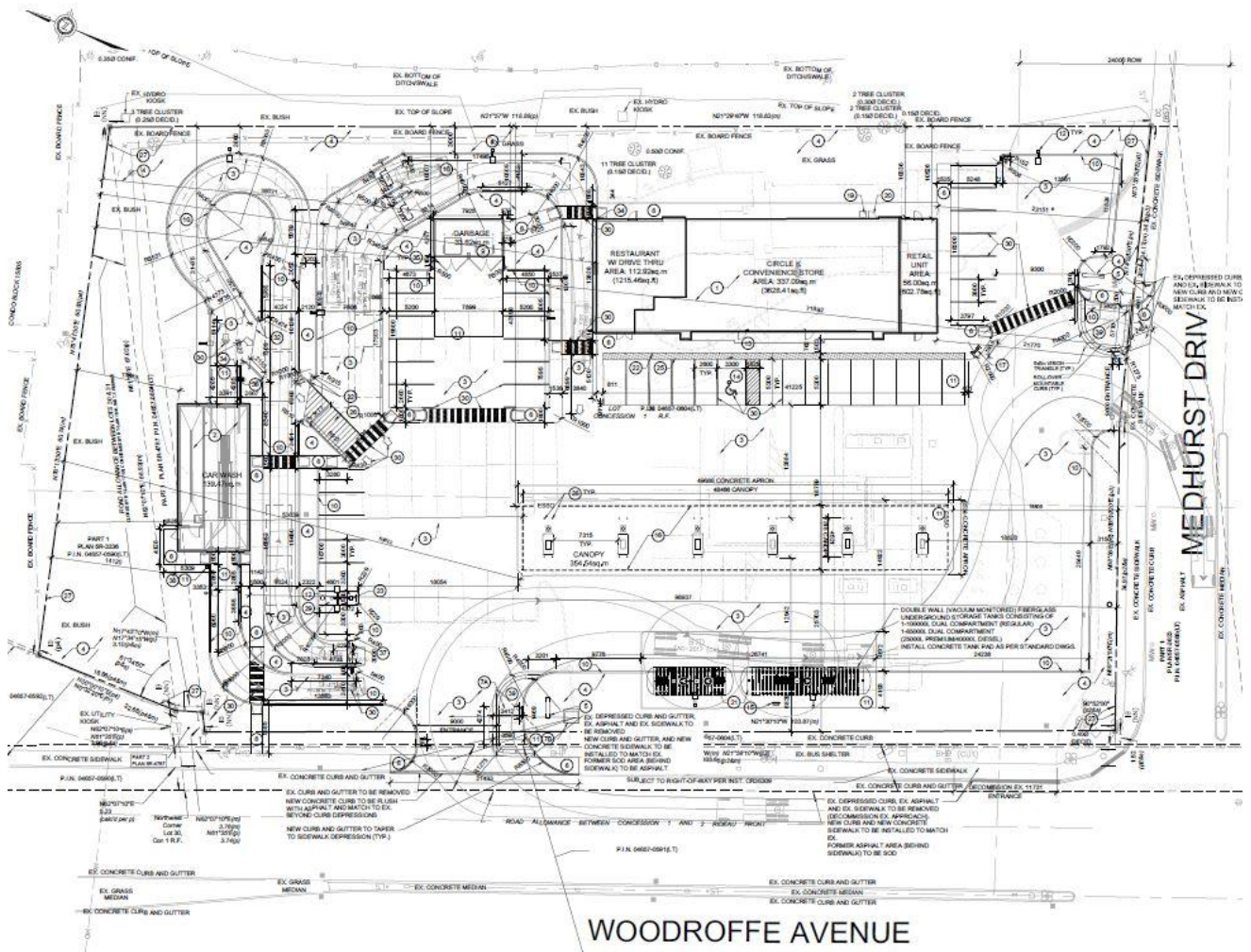

Figure 3 – Proposed Development

2. Sanitary Servicing

2.1. Sanitary Sewer System

Sanitary sewage outflow from the site is calculated using the current Engineering Design Criteria for the City of Ottawa. Sewage flows will be calculated based on use as a commercial site with an average design flow of 28,000 L/ha/day plus allowances for infiltration. Based on the site area of 0.82 hectares, the average estimated daily flow equates to 22,960 L/day or **0.27 l/s**.

In accordance with City Design Criteria, applying a peaking factor of 1.5, the peak sanitary discharge for the Circle-K site will be $1.5 \times 0.27 \text{ l/s} = \mathbf{0.41 \text{ l/s}}$. An infiltration allowance of 0.28 L/s/hectare will be required to be incorporated into the sanitary sewer discharge rate.

*Therefore, the sanitary discharge rate = 0.41 litres/second + l/l (Site area) = (0.41 l/s) + (0.28 l/s/ha * 0.82 ha) = 0.64 litres/second.*

Estimated Car Wash Demand

A carwash is included in the proposed development which will discharge to the proposed sanitary sewer system on site. The sanitary discharge for the car wash is as follows:

- Carwash cycle water usage: Basic - 130 L, Full - 175 L, Premium - 290 L
- Average usage of 175 L / wash cycle
- Carwash cycle time: 2 minutes washing plus 2 minutes dry time = 4 minutes total

Therefore, peak carwash flow rate = 175 L per 4 minutes = 43.75 L/min or 0.73 litres/second

Peak Sanitary Demand

The total peak sanitary discharge is therefore $0.64 \text{ l/s} + 0.73 \text{ l/s} = \mathbf{1.37 \text{ l/s}}$.

The sanitary sewage flow from the proposed Circle K site will discharge to the existing 300mm diameter PVC sanitary sewer main located within the Medhurst Drive ROW. Refer to Appendix D for the sanitary design sheet and drainage plan.

2.2. Sanitary Service Connection

Sewage flows from the building and the car wash facility will be collected in a series of 200mm diameter sewers and flow through the site, ultimately discharging by gravity to a proposed sampling sanitary manhole at the south frontage of Medhurst Drive. Due to the nature of the sewage, an oil and grease interceptor will be included prior to discharging flows from the restaurant portion of the building. The car wash facility also includes a water re-claim and treatment structure prior to discharging into the proposed sanitary system. The existing sanitary sewers, as well as the proposed sanitary sewer arrangement for the Circle K Development are shown on Drawing C-02 – Site Servicing Plan (see Appendix A).

2.3. Recommendations

The proposed sanitary sewage flows within the development will be conveyed via a series of 200mm diameter sewers, connecting to a proposed manhole located within the Medhurst Drive ROW immediately outside of the site. The proposed site is being reconstructed with similar facilities and functions as the existing site. Therefore, sanitary flows are expected to remain similar to the existing discharge from the site into the existing municipal sanitary sewer system. It is anticipated that the existing sanitary sewer will have adequate capacity to receive flows from the proposed development.

3. Water Distribution

3.1. Proposed Water Servicing System

Construction record drawings for the Medhurst Drive and Woodroffe Avenue area indicate that there is an existing 305 mm diameter watermain located along the frontage of the Medhurst Drive. There is also a 406 mm and a 1220 mm backbone watermain within the Woodroffe Avenue ROW. It is proposed that the site will be serviced via a new 100mm diameter water service for domestic flow, connected into the existing 305 mm diameter watermain on Medhurst Drive.

Car wash water consumption rate was calculated above as an average of 0.73 l/s. Water demands for the remainder of the proposed development were determined from the City of Ottawa Design Criteria, which recommends a water consumption for commercial uses as 28m³/ha/day.

Maximum daily demand and peak hour water demand estimates are based on the City's peaking factors of 1.5 and 1.8 respectively, for commercial use.

$$\text{Average daily water demand} = (28 \text{ m}^3/\text{ha}/\text{day}) * 0.82\text{ha} / 86400 * 1000 = 0.27 \text{ litres/second}$$

$$\text{Total Water Demand} = 0.73 \text{ l/s (Car Wash)} + 0.27 \text{ l/s (Domestic)} = 1.0 \text{ l/s}$$

$$\text{Maximum daily demand} = (1.0 \text{ l/s}) * (1.5) = 1.5 \text{ litres/second}$$

$$\text{Peak hour water demand} = (1.5 \text{ l/s}) * (1.8) = \mathbf{2.7 \text{ litres/second}}$$

A detailed Fire Flow calculation has been prepared using the recommendation for the Fire Underwriters Survey. The fire flow calculation indicates that the recommended fire flow for this proposed development will be **9,000 l/min (150 litres/sec)**. Calculations for the required domestic and fire flow demand are provided in Appendix B.

The total water demand for the site is estimated as the maximum day water demand plus fire, resulting in a total demand of approximately (1.5 l/s + 150 l/s) = **151.50 l/s** or (9,090 litres/min). A 100mm diameter water service would be enough to supply up to 9,090 litres/minute assuming a water velocity of 5 m/s and an average pressure range of 60 psi at the street line.

Currently, there is an existing fire hydrant located on the north side of Woodroffe Avenue adjacent the site for fire fighting purposes. A fire hydrant flow test has been conducted to confirm there is adequate pressure in the system for firefighting purposes. The hydrant test has been included in Appendix B and confirms there is a projected 29,045 l/min flow available at 140 kPa.

Refer to the Site Servicing Plan in Appendix A showing the extent of proposed water servicing to be installed.

3.2. Recommendations

The existing municipal watermain located within the Medhurst Drive ROW has enough capacity to support the proposed development for both domestic and fire flow purposes. There is adequate coverage from the existing fire hydrant and modifications or upgrades to the existing watermains located within the Medhurst and Woodroffe ROWs will not be required to support the proposed development.

4. Stormwater Management Analysis

Stormwater management design for this development was carried out in accordance with all applicable design standards including but not limited to:

- Ontario Ministry of the Environment - Stormwater Management Planning and Design Manual, March 2003
- Rideau Valley Conservation Authority (RVCA) Development Policies
- Pinecrest Creek/Westboro Area Subwatershed Study Area
- City of Ottawa Engineering Design Criteria, latest version

To design the facilities to meet these requirements, it is essential to select the appropriate modelling methodology for the storm system design. Since this is a small site, (~1 ha), and since it is not necessary to match the timing of the peak release rate to the pre-development conditions, complex modelling techniques are not necessary and are typically inaccurate for a site of this size. The Modified Rational Method is adequate to conform the required storm volumes to control post development runoff conditions.

A portion of the north and northwest perimeter of the site will remain undisturbed, flowing uncontrolled to the west. The existing (0.043 ha) wooded area will remain, thus, will be omitted from the stormwater management analysis.

5.1. Allowable Release Rate

The existing 1050mm diameter storm sewer on Medhurst Drive has been designed to accommodate the stormwater flow from the subject site at a run-off co-efficient of 0.70. This value has been used to determine the allowable release rate for the site. The municipal storm sewer connects to an 1800mm diameter storm sewer a short distance away, which crosses Woodroffe avenue where it then connects to a 2400mm diameter storm sewer that flows north eventually discharging to Pinecrest Creek.

Contributing Drainage Area = 0.778 ha

Runoff coefficient C = 0.70

Table 2: Allowable Release Rate

Storm Event (yr.)	Rainfall Intensity (mm/hr)	Allowable Release Rate (L/s)
2	76.81	116.19
5	104.19	157.62
10	122.14	184.77
25	144.69	218.89
50	161.47	244.27
100	178.56	270.12

For detailed calculations see Appendix C.

5.2. Stormwater Quantity Management

As the development will change the site imperviousness, it is important to quantify this to determine the proposed storm runoff rates. Based on the post development surface conditions, the weighted runoff coefficient of the site is 0.80. Refer to Appendix C for detailed breakdown of the post-development run-off coefficient.

The development of this site would otherwise increase the rate of stormwater runoff, more than the allowable design flows as determined above. On-site quantity controls are required to protect the integrity of the surrounding areas. Storm water quantity will be controlled through an orifice tube located within the downstream end of the system to ensure that post development flows from the site will be controlled to the allowable release rate for storm events up to and including the 100-year storm event.

There are multiple scenarios that must be considered for this site based on the information provided in the pre-consultation meeting with the City of Ottawa. The first is to limit the peak discharge to the more stringent of: (1a) the peak discharge from a 5-year storm considering a runoff coefficient of $C=0.5$ as per the City of Ottawa Design Guidelines, or (1b) 33.5L/s/ha as per the SWM Guidelines for the Pinecrest Creek / Westboro Area. The second scenario is to limit the peak discharge during the 25mm design storm such that the peak outflow does not exceed 5.8L/s/ha as per the SWM Guidelines for the Pinecrest Creek / Westboro Area. This amounts to a peak discharge rate of 4.76L/s during the 25mm design storm. Therefore, on-site stormwater detention is required to enable a controlled maximum discharge rate under the two scenarios.

Scenario #1

The allowable peak 5-year storm considering a runoff coefficient of $C=0.5$ is calculated using the IDF coefficients for a 5-year storm event. The peak development flow is controlled to a runoff coefficient of 0.5 at a time of concentration of 10 minutes, the allowable flow is therefore:

$$Q_A = 0.5 \times 104.19 \text{ mm/hr} \times 7780 \text{ m}^2 / 3600$$

$$Q_A = 112.58 \text{ L/s}$$

$$33.5 \text{ L/s/ha} \times 0.778 \text{ ha} = \mathbf{26.06 \text{ L/s}}$$

Thus, the Pinecrest Creek / Westboro Area maximum discharge rate is the more stringent criteria and will be used to calculate maximum allowable site discharge rates.

Scenario #2

Based on the size of the site, the allowable storm discharge rate corresponds to a runoff of $5.8\text{L/s/ha} \times 0.778 \text{ ha} = 4.51\text{L/s}$

A VO2 model has been prepared to analyze the stormwater management for the site. Refer to Appendix C for detailed output files.

Stormwater Detention

Storage will be provided via underground pipe and manhole storage, as well as additional underground storage chambers to meet the volumes required per the findings of the quantity control analysis.

A total volume of 297.80 m^3 storage is required to meet post-development flows to allowable release rates (see Appendix C). The total volume available in the storm system including pipe and structures is approximately 72.8 m^3 . Therefore, additional storage will be required elsewhere in the storm system. Table 6.3 below summarizes the available storage for this development. Detailed calculations are provided in Appendix C.

Table 3: Available Stormwater Storage without Additional storage measures

Pipe (m^3)	Catchbasin / Manholes (m^3)	Surface (m^3)	Total Storage (m^3)
52.30	20.5	-	72.80

As seen above, storage provided via roof control, parking lot surface storage and pipe storage was deemed to be insufficient to meet the storage volumes required per the findings of the quantity control analysis. Further, it is not recommended to provide surface storage due to site uses, and potential for stormwater contamination from fuel spills. Therefore, an underground storage system will be necessary to provide quantity control storage volume. Two options were explored including the use of oversized pipes and storage chambers. It was determined that the use of sub-surface storage chambers was more cost effective than the oversized pipe option, thus the use of sub-storage chambers was selected as the preferred underground storage option.

A subsurface stormwater storage system (i.e., Stormtech underground storage chambers) has been specified to provide overall site stormwater quantity control volume. The proposed Stormtech stormwater storage systems will provide a total storage volume of 225 m³. Refer to Appendix C for Stormtech Storage Calculations. The layout of Stormtech subsurface stormwater detention facility is shown on the Site Servicing Plan, Drawing C02.

Outlet Control

The preferred method for restricting the stormwater discharge from the site into the storm system is through the installation of an orifice tube. This orifice is designed to release the specified flow of stormwater under the hydraulic head conditions present, based upon the formula:

$$A = Q / [c \sqrt{(2 g h)}]$$

Where:

A = Orifice Area (m²)

Q = Allowable discharge (m³)

c = 0.82 (orifice tube coefficient)

g = Gravitational Constant = 9.81 m/s²

h = Height of water over the center of orifice (m)

The post-development flows will be restricted by the orifice tube and released to the allowable discharge rates for all storm events. The controlled flow restriction will affect the required ponding of stormwater for on-site detention. Refer to Table 4 for required storage, as well as demonstration that post-development flows will be restricted to the allowable rate for all storm events up to the 100-year event. The orifice is proposed to be located upstream of MH2, as shown on Site Servicing Plan, drawing C-02 (Appendix A).

Table 4: Post-Development Controlled Peak Flow and Storage

Storm Event (yr.)	Allowable Release Rate (L/s)	Controlled Peak Flow (L/s)	Storage Required (m ³)	Storage Available (m ³)
2	122.61	7.36	110.82	297.80
5	166.33	10.86	143.81	
10	194.99	14.97	158.65	
25	230.99	20.89	200.62	
50	257.77	23.30	231.39	
100	285.05	25.89	274.79	

For detailed calculations see Appendix C.

5.3. Stormwater Quality Management

The stormwater quality control for the development will adhere to the Rideau Valley Conservation Authority stormwater management criteria. This target is achieved through the proposed stormwater management system.

The design of the onsite storm sewer drainage system will incorporate a stormwater quality treatment unit. Sizing calculations confirm that a model Stormceptor EF06 will provide 61% long-term TSS removal efficiency with 90% of the average annual runoff treated. The Stormceptor sizing is based on a 0.778 ha drainage area with runoff coefficient 0.80. The Stormceptor will be installed at the location shown on the Site Servicing Plan, drawing C-02, downstream of manhole MH2.

Refer to Appendix C for sizing calculation of the Stormceptor oil/grit separator model EF06.

Additionally, the Low Impact Development (L.I.D) feature in the form of “Enhanced Grass Swales” in the landscape areas will be included in the system to maximize the natural infiltration and retention of rainwater through site development and further enhance stormwater quality. Further LID features, such as infiltration trenches, permeable pavers or rainwater harvesting have been considered, however due to the site use would not be appropriate in this case given the potential for groundwater contamination.

5.4. Storm Conveyance

The subject site currently drains to existing 1050 diameter concrete storm sewer on Medhurst Drive. All outflow from the site will be directed via perimeter swales, catchbasins and roof drains and outlet south of the site utilizing the same receiving municipal sewer. There will be small areas around the perimeter of the site to drain uncontrolled to the municipal ROW to accommodate the proposed development.

The proposed grading will maintain the existing drainage patterns as much as possible to avoid drainage diversion. As shown in the site grading and site servicing drawings (Appendix A) this site has been designed to integrate both minor and major storm systems. The overall site grading ensures that the existing drainage pattern on adjacent properties have not been altered and stormwater runoff from the subject development has been self-contained.

Minor System: Storm Sewer

The site has been graded to contain the stormwater from the site, and to direct it through a series of catchbasins located throughout the site and roof water leaders on the building. These catchbasins and roof drains flow into an underground storm sewer system (minor system). The underground storm sewer has been designed to accommodate the 10-year peak storm event based on City of Ottawa Intensity Duration Frequency (IDF) curve with Time of Concentration of (Tc) 10 minutes, using Rational Method. Storm sewer sizing and gradients will maintain a minimum velocity of 0.9 m/sec and maximum 4.0 m/sec. The detailed design of the minor system is provided in Storm Design Sheet in Appendix C.

Major System: Overland Flow

In the event of a major storm, defined as storms larger than the 2-year event and up to the 100-year event, the outlet control provided in the system in the form of an orifice tube will utilize the available storm sewer infrastructure by allowing the system to back up, thus providing the required storage. Outlet controls in the sewer system are designed to restrict the post-development flows exiting from the system to an allowable release rate and effectively restrict the flows by detaining the water in the system to release it at an allowable release rate and will not have any impact on downstream overland flow capacity.

The controlled release rates of stormwater are directed to a Stormceptor to ensure that runoff from the site is treated to RVCA water quality requirements before it is released from the site.

In events larger than the 100-year return storm, the site has been graded to include an overland flow route. This route allows the stormwater to overtop the local highpoints and flow overland and off-site to Woodroffe Avenue, consistent with the existing overland flow route.

The major overland flow routes are shown on the Site Grading Plan, drawing C-01, in Appendix A.

5.5. Erosion Control

As this development requires site grading and excavation, there will be a potential for soil erosion and off-site release of sediment during the construction phase. Sediment Control in accordance with the City and CA standards are to be implemented during construction to ensure the quality of stormwater runoff during construction. It is essential that effective environmental and sedimentation controls be in place and maintained throughout the site during all construction activities. It is recommended that the following be implemented on a temporary basis to assist in achieving acceptable runoff quality during construction. Refer to Appendix A for Erosion and Sediment Control Plan Drawing C03.

- Installation and maintenance of silt fences around the entire perimeter of the site for the duration of the construction period.
- Provision of a mud mat construction entrance to control the tracking of sediment and debris onto adjacent streets.
- Installation and maintenance of catchbasin sediment barriers throughout the site and during all construction activities to reduce and trap sediment on site. Constant attention will be paid to maintaining them silt free. All catchbasin grates shall be covered with geo-textile filter fabric during the period of construction of the proposed works.
- Reduce stormwater drainage velocities where possible.
- All topsoil stockpiles to be surrounded with sediment control fencing.

To ensure the functionality of the erosion and sediment control measures, inspection and maintenance of the systems shall be performed on a weekly basis and after every rainfall event during construction. The sediment and erosion control measures shall not be removed until final asphalt paving and/or sodding are complete.

5.6. Water Balance

The water balance target for the development is to retain the first 10mm runoff through infiltration, evapotranspiration, and rainwater reuse as per RVCA's requirements. Various Low Impact Development (LID) measures were considered. The required water balance volume for the development area is 82.0 m³. Due to the nature of the site, it is not recommended to provide any infiltration or other similar LID measures. However, landscape areas will provide some additional water balance benefit. Although the post-development water balance target has not been achieved across the entire site, the water balance will not significantly change from the pre-development conditions.

5. Utilities

The proposed development is located within a serviced area of the City of Ottawa with Gas, Hydro and Bell infrastructure existing within the adjacent municipal road allowances. During the detailed engineering design stage, consultation with each of the utilities will be necessary to provide the utilities with specific load requirements for the development and proposed service entry locations. This will allow each utility to assess if any upgrading of their distribution system in the area is required.

6. Conclusions

Grading, Drainage and Stormwater Management

The site will be graded in accordance with the appropriate design criteria and all surface runoff from the site will be directed to the underground stormwater management system. Provisions for an emergency overland flow route will be incorporated into the design and allow stormwater runoff to discharge from the site safely and appropriately.

Water Servicing

The provision of domestic and fire protection to the proposed development can be accomplished satisfactorily. It is proposed that the development be serviced off the existing 305mm diameter watermain located within the Medhurst Drive ROW. A 100mm water service connection will be tapped off the existing 305mm diameter watermain. The water service connection would enter the meter room of the C-store building.

Sanitary Servicing

Sanitary Servicing for the proposed development can be accomplished satisfactorily. The proposed sanitary sewage flows within the development will be conveyed via a series of 200mm diameter sewers connecting to a new manhole within the Medhurst Drive ROW immediately south of the site. Sanitary discharge will flow by gravity into the municipal sewer.

Utilities

Utilities can be provided satisfactorily. Hydro, communications, and gas infrastructure will be available adjacent to the property for connection from the municipal road right of way. Consultation with each of the utilities is underway to provide the utilities with specific load requirements for the development and proposed service connection points. This will allow each utility to assess if any upgrading of their distribution system in the area is required.

Sincerely,
EXP Services Inc



Jordan Stern, P.Eng.
Project Engineer

Crystal Frazao
Project Manager

- Appendix A – C-01, Site Grading Plan
- C-02, Site Servicing Plan
- C-03, Erosion and Sediment Control Plan

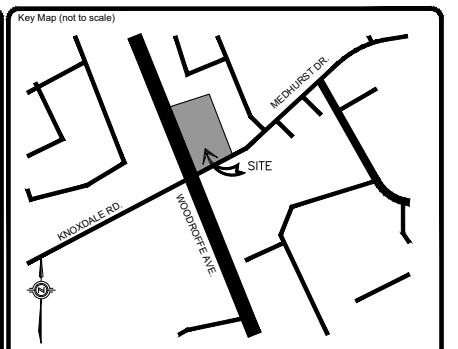
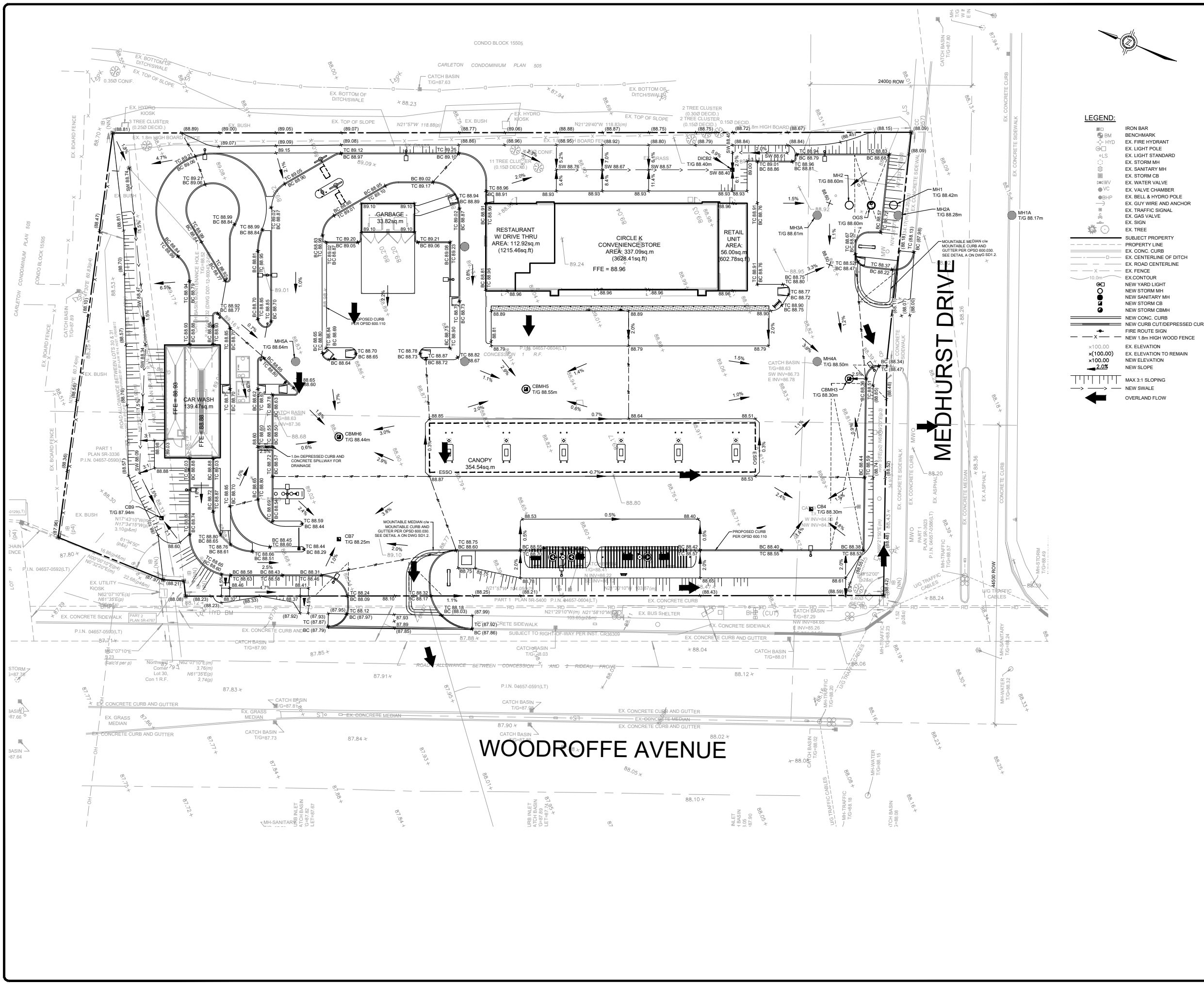

- LEGEND:**
- IRON BAR
 - BM
 - HYD
 - LS
 - MV
 - VC
 - BHP
 - EX. TREE
 - SUBJECT PROPERTY
 - PROPERTY LINE
 - EX. CONC. CURB
 - EX. CENTERLINE OF DITCH
 - EX. ROAD CENTERLINE
 - EX. FENCE
 - EX. CONTOUR
 - NEW YARD LIGHT
 - NEW STORM MH
 - NEW SANITARY MH
 - NEW STORM CB
 - NEW STORM CBMH
 - NEW CONC. CURB
 - NEW CURB CUT/DEPRESSED CURB
 - FIRE ROUTE SIGN
 - NEW 1.8m HIGH WOOD FENCE
 - EX. ELEVATION
 - EX. ELEVATION TO REMAIN
 - NEW SLOPE
 - MAX 3:1 SLOPING
 - NEW SWALE
 - OVERLAND FLOW

No.	REVISIONS	Date	By	App.
D	RE-ISSUED FOR SPA	SEPT 24 2021	ML	J.S.
C	ISSUED FOR COORDINATION	AUG 18 2021	ML	J.S.
B	ISSUED FOR SPA	APR 27 2021	LMB	J.S.
A	ISSUED FOR COORDINATION	APR 21 2021	LMB	J.S.

exp Services Inc.
 t: +1.905.793.9800 f: +1.905.793.0641
 1595 Clark Boulevard
 Brampton, ON L6T 4V1
 Canada
www.exp.com

- BUILDINGS • EARTH & ENVIRONMENT • ENERGY •
- INDUSTRIAL • INFRASTRUCTURE • SUSTAINABILITY •

Owner/Client:

Location:
1545 WOODROFFE AVE.
OTTAWA, ON

Title:
GRADING PLAN

Designed By: LMB	Drawn By: LMB	Checked By: J.S.
Scale: 1:250	Date: APRIL 2020	City Drawing No.:
Project No.: BRM00606364-B0		Drawing No.: C01

CITY DWG. # 17094

NOTE
 ALL EXISTING UNDERGROUND
 INFRASTRUCTURE LOCATED WITHIN THE
 SITE BOUNDARY TO BE REMOVED. ALL
 EXISTING STORM, SANITARY AND
 WATERMAIN SERVICE CONNECTIONS TO BE
 CAPPED AT THE PROPERTY TO THE
 SATISFACTION OF THE CITY OF OTTAWA.

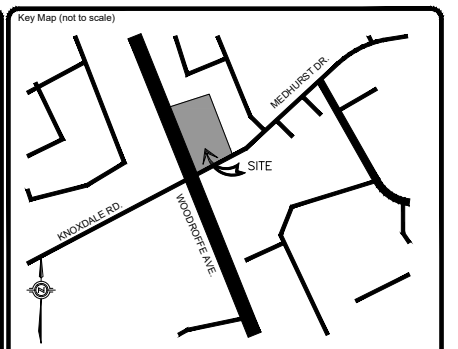
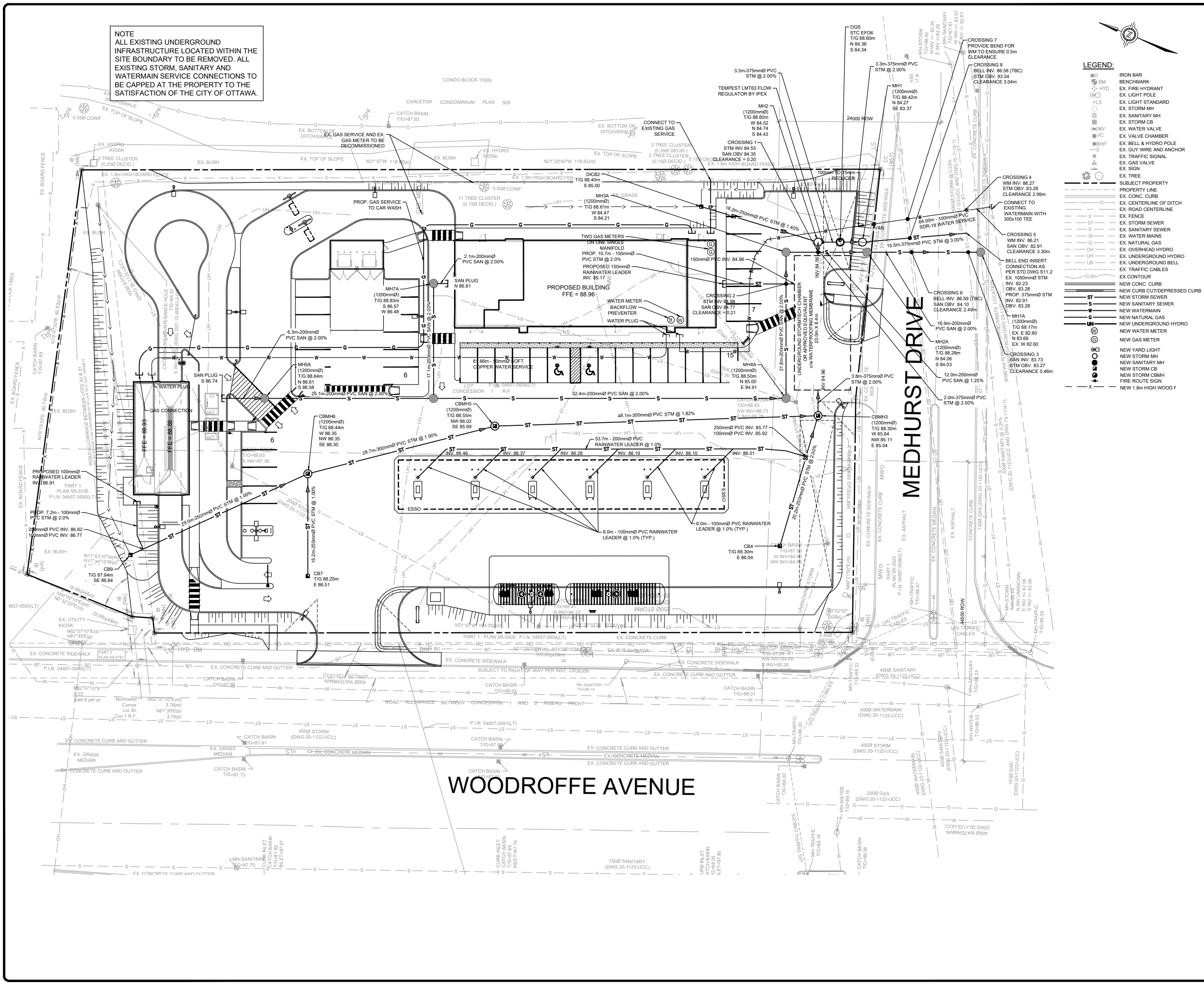

- LEGEND:**
- IRON BAR
 - BENCHMARK
 - EX. FIRE HYDRANT
 - EX. LIGHT POLE
 - EX. LIGHT STANDARD
 - EX. STORM MH
 - EX. SANITARY MH
 - EX. STORM CB
 - EX. WATER VALVE
 - EX. VALVE CHAMBER
 - EX. BELL & HYDRO POLE
 - EX. GUY WIRE AND ANCHOR
 - EX. TRAFFIC SIGNAL
 - EX. GAS VALVE
 - EX. SIGN
 - EX. TREE
 - SUBJECT PROPERTY
 - PROPERTY LINE
 - EX. CONC. CURB
 - EX. CENTERLINE OF DITCH
 - EX. ROAD CENTERLINE
 - EX. FENCE
 - EX. STORM SEWER
 - EX. SANITARY SEWER
 - EX. WATER MAINS
 - EX. NATURAL GAS
 - EX. OVERHEAD HYDRO
 - EX. UNDERGROUND HYDRO
 - EX. UNDERGROUND BELL
 - EX. TRAFFIC CABLES
 - EX. CONTOUR
 - NEW CONC. CURB
 - NEW CURB CUT/DEPRESSED CURB
 - NEW STORM SEWER
 - NEW SANITARY SEWER
 - NEW WATERMAIN
 - NEW NATURAL GAS
 - NEW UNDERGROUND HYDRO
 - NEW WATER METER
 - NEW GAS METER
 - NEW YARD LIGHT
 - NEW STORM MH
 - NEW SANITARY MH
 - NEW STORM CB
 - NEW STORM CBMH
 - FIRE ROUTE SIGN
 - NEW 1.8m HIGH WOOD F

No.	REVISIONS	Date	By	App.
D	RE-ISSUED FOR SPA	SEPT 24 2021	ML	J.S.
C	ISSUED FOR COORDINATION	AUG 18 2021	ML	J.S.
B	ISSUED FOR SPA	APR 27 2021	LMB	J.S.
A	ISSUED FOR COORDINATION	APR 22 2021	LMB	J.S.

exp Services Inc.
 t: +1.905.793.9800 | f: +1.905.793.0641
 1595 Clark Boulevard
 Brampton, ON L6T 4V1
 Canada
 www.exp.com

- BUILDINGS • EARTH & ENVIRONMENT • ENERGY •
- INDUSTRIAL • INFRASTRUCTURE • SUSTAINABILITY •

Owner/Client:

Location:
1545 WOODROFFE AVE.
OTTAWA, ON

Title:
SERVICING PLAN

Designed By: LMB	Drawn By: LMB	Checked By: J.S.
Scale: 1:250	Date: APRIL 2020	City Drawing No.: C02
Project No.: BRM00606364-B0		CITY DWG. # 17094

CITY # 007-12-21-0066

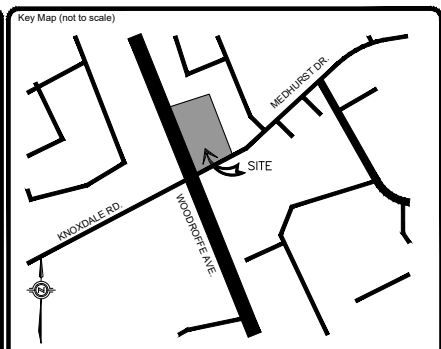
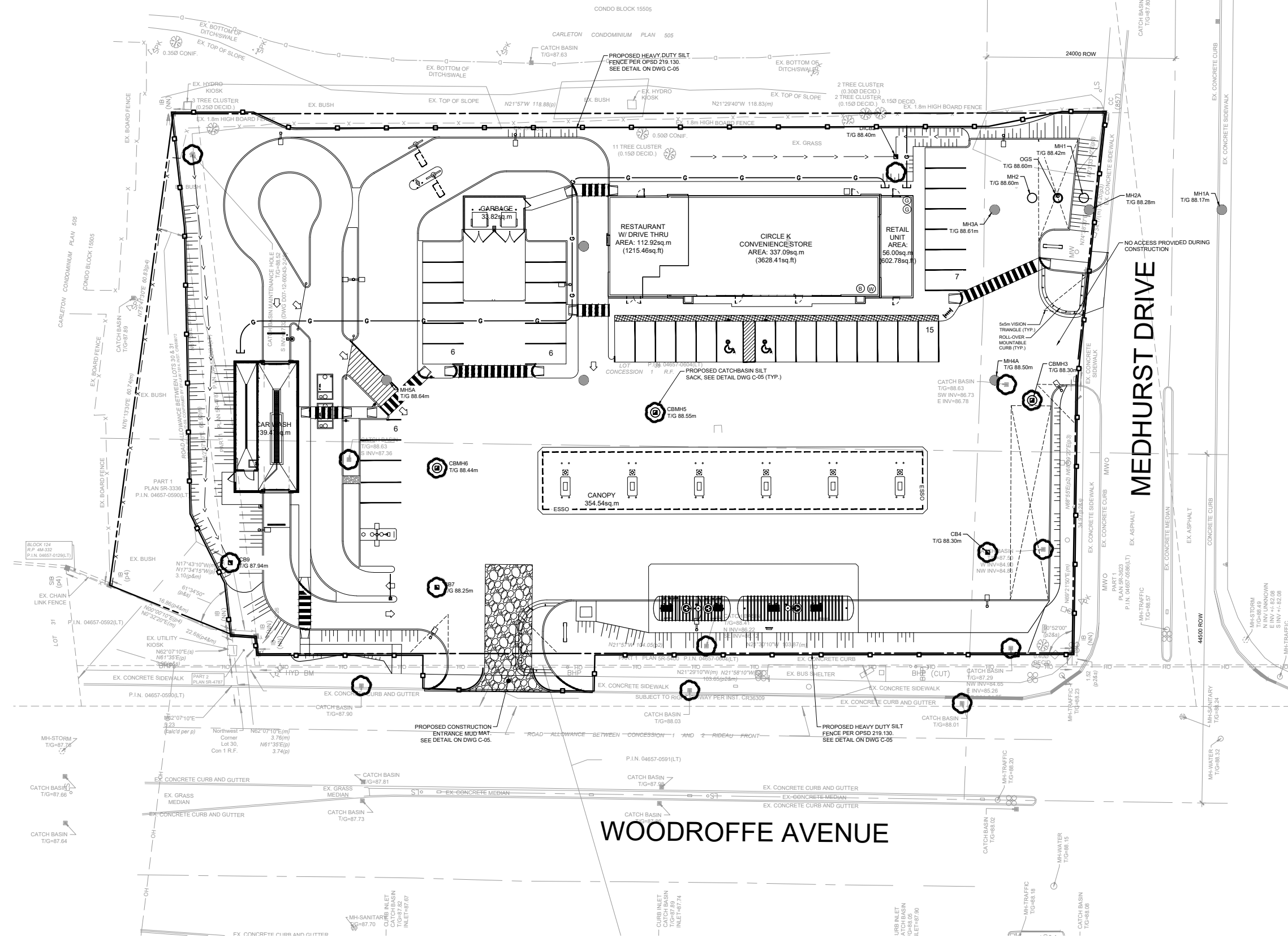

- LEGEND:**
- ⊠ IRON BAR
 - ⊡ BENCHMARK
 - ⊙ EX. FIRE HYDRANT
 - ⊕ EX. LIGHT POLE
 - ⊖ EX. LIGHT STANDARD
 - ⊗ EX. STORM MH
 - ⊘ EX. SANITARY MH
 - ⊙ EX. STORM CB
 - ⊖ EX. WATER VALVE
 - ⊗ EX. VALVE CHAMBER
 - ⊘ EX. BELL & HYDRO POLE
 - ⊙ EX. GUY WIRE AND ANCHOR
 - ⊖ EX. TRAFFIC SIGNAL
 - ⊗ EX. GAS VALVE
 - ⊘ EX. SIGN
 - ⊙ EX. TREE
 - SUBJECT PROPERTY
 - PROPERTY LINE
 - EX. CONC. CURB
 - EX. CENTERLINE OF DITCH
 - EX. ROAD CENTERLINE
 - EX. FENCE
 - EX. CONTOUR
 - ⊙ NEW YARD LIGHT
 - ⊙ NEW STORM MH
 - ⊙ NEW SANITARY MH
 - ⊙ NEW STORM CB
 - ⊙ NEW STORM CBMH
 - ⊙ NEW CONC. CURB
 - ⊙ NEW CURB CUT/DEPRESSED CURB
 - ⊙ EREction SIGN
 - ⊙ NEW 1.8m HIGH WOOD FENCE
 - ⊙ MUD MAT
 - ⊙ SILT FENCE

No.	REVISIONS	Date	By	App.
D	RE-ISSUED FOR SPA	SEPT 24 2021	ML	J.S.
C	ISSUED FOR COORDINATION	AUG 12 2021	ML	J.S.
B	ISSUED FOR SPA	APR 27 2021	LMB	J.S.
A	ISSUED FOR COORDINATION	APR 22 2021	LMB	J.S.



exp Services Inc.
 t: +1.905.793.9800 f: +1.905.793.0641
 1595 Clark Boulevard
 Brampton, ON L6T 4V1
 Canada
 www.exp.com



- BUILDINGS • EARTH & ENVIRONMENT • ENERGY •
- INDUSTRIAL • INFRASTRUCTURE • SUSTAINABILITY •



Location:
**1545 WOODROFFE AVE.
 OTTAWA, ON**

Title:
**EROSION AND SEDIMENT
 CONTROL PLAN**

Designed By: LMB	Drawn By: LMB	Checked By: J.S.
Scale: 1:250	Date: APRIL 2020	City Drawing No.: C03
Project No.: BRM00606364-B0		

CITY DWG. # 17094

Appendix B – Firefighting Water Design Calculations



FIRE UNDERWRITERS SURVEY FIRE FLOW CALCULATIONS

F = the required fire flow in litres per minute

C = Coefficient related to the type of construction

$$F = 220C\sqrt{A}$$

C Values

1.5 = wood frame construction (structure essentially all combustible)

1.0 = ordinary construction (brick or other masonry walls, combustible floor and interior)

0.8 = non-combustible construction (unprotected metal structural components, masonry or metal walls)

0.6 = fire resistive construction (fully protected frame, floors, roof)

A = the total floor area in square metres (including all storeys, but excluding basements at least 50 percent below grade) in the building considered

Area ID	A (sq.m)	C	F (L/min)*	Occupancy Adjustment	F (adjusted)	Automatic Sprinkler Adjustment (%)	Exposure Increase (%)	F (final) (L/min)*
Proposed Building (Car Wash)	140.00	1.0	3000	25%	3750	0%	15%	4000
Proposed Building (C-Store)	640.00	1.0	6000	25%	7500	0%	15%	9000

Maximum Fire Flow Rate Req'd = 9000

*rounded to the nearest 1,000 L/min per the Fire Underwriters Survey procedure guidelines



LHS INC.

P.O. Box 712 Cobourg ON K9A 4R5

905-377-0715 / 1-866-622-4022

Email: info@lhsinc.com

Client	EXP Services Inc 1595 Clark Boulevard Brampton	Site	1545 Woodroffe Ave
		Site Contact Phone	

FIRE FLOW TEST

Fire Flow Date	August 13, 2021 - 1:53 pm	Hydrant Colours	RED - C	0-500
Site	1545 Woodroffe Ave		ORANGE - B	500-1000
Static Hydrant	Corner of Woodroffe at Medhurst		GREEN - A	1000-1500
Flow Hydrant	1545 Woodroffe Ave		BLUE - AA	>1500

Single Port

Static	55 psi
Residual 1	54 psi
Flow	45 psi
Observed	1125 US GPM 937 IMP GPM 4259 L / MIN
Projected @ 20psi	7673 US GPM 6389 IMP GPM 29045 l/min.

Two Port

Static	55 psi
Residual 2	53 psi
Flow 2 (x2)	25 psi
Observed	1677 US GPM 1397IMP GPM 6349 L / MIN
Projected @ 20psi	7867 US GPM 6551 IMP GPM 29780 l/min.

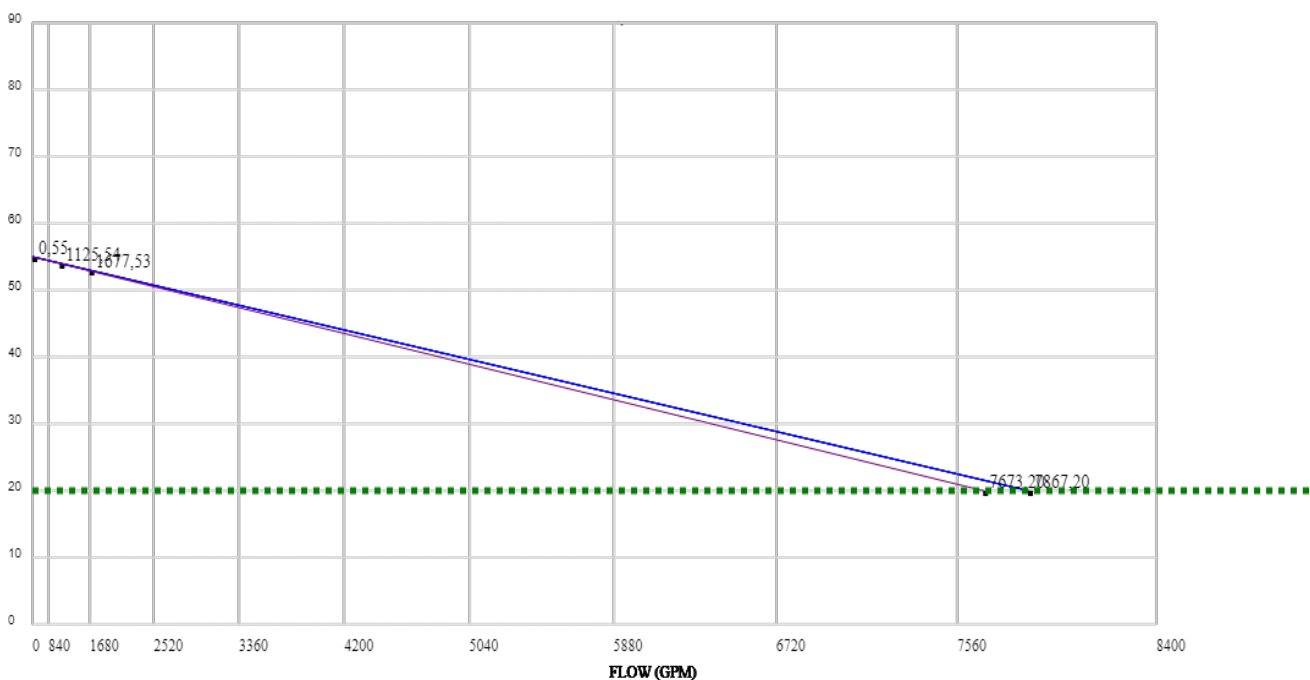

Appendix C – Stormwater Management Design Calculations

PROJECT NO. : BRM-00606364-B0
 PROJECT NAME. : Circle K - Nepean
 Date: August, 2021



CALCULATION Sheet : 1

Available Storage

Water Level	AVAILABLE STORAGE					
	Pipe	Catch Basins	CBMH	Surface	Cultec	Total
(m)	(m3)	(m3)	(m3)		(m3)	(m3)
84.43	0.00	0.00	0.00		0.00	0.00
84.58	3.74	0.00	0.17		27.50	31.41
84.73	7.47	0.00	0.34		55.00	62.81
84.88	11.21	0.00	0.51		82.50	94.22
85.03	14.94	0.00	0.71		110.00	125.66
85.18	18.68	0.00	1.21		137.50	157.39
85.33	22.41	0.00	1.72		165.00	189.13
85.48	26.15	0.00	2.23		192.50	220.88
85.63	29.89	0.03	2.74		220.00	252.65
85.78	33.62	0.08	3.25		247.50	284.45
85.93	37.36	0.13	3.75		275.00	316.25
86.08	41.09	0.19	4.37		302.50	348.15
86.23	44.83	0.24	5.11		330.00	380.18
86.38	48.56	0.30	5.96		357.50	412.33
86.53	52.30	0.49	6.81		385.00	444.60
86.68	52.30	0.76	7.66		412.50	473.22
86.83	52.30	1.03	8.50		440.00	501.84
86.98	52.30	1.30	9.35		440.00	502.96
87.13	52.30	1.57	10.20		440.00	504.07
87.28	52.30	1.84	11.05		440.00	505.19
87.43	52.30	2.11	11.90		440.00	506.31
87.58	52.30	2.38	12.75		440.00	507.43
87.73	52.30	2.65	13.59		440.00	508.55
87.88	52.30	2.92	14.44		440.00	509.67
87.98	52.30	3.10	15.01		440.00	510.41
88.10	52.30	3.32	15.69		440.00	511.31
88.13	52.30	3.37	15.86		440.00	511.53
88.18	52.30	3.46	16.14		440.00	511.90
88.22	52.30	3.54	16.37		440.00	512.20
88.30	52.30	3.68	16.82	0.00	440.00	512.80

PROJECT NO. : BRM-00606364-B0
 PROJECT NAME. : Circle K - Nepean
 Date: August, 2021



Orifice Coefficient =	0.62
Invert =	84.43 m
Orifice Plate =	40 mm

Water Level (m)	AVAILABLE STORAGE					
	Pipe (m3)	Catch Basins (m3)	CBMH (m3)	Surface (m3)	Cultec (m3)	Total (m3)
84.43	0.00	0.00	0.00	0.00	0.00	0.00
84.58	3.74	0.00	0.17	0.00	27.50	31.41
84.73	7.47	0.00	0.34	0.00	55.00	62.81
84.88	11.21	0.00	0.51	0.00	82.50	94.22
85.03	14.94	0.00	0.71	0.00	110.00	125.66
85.18	18.68	0.00	1.21	0.00	137.50	157.39
85.33	22.41	0.00	1.72	0.00	165.00	189.13
85.48	26.15	0.00	2.23	0.00	192.50	220.88
85.63	29.89	0.03	2.74	0.00	220.00	252.65
85.78	33.62	0.08	3.25	0.00	247.50	284.45
85.93	37.36	0.13	3.75	0.00	275.00	316.25
86.08	41.09	0.19	4.37	0.00	302.50	348.15
86.23	44.83	0.24	5.11	0.00	330.00	380.18
86.38	48.56	0.30	5.96	0.00	357.50	412.33
86.53	52.30	0.49	6.81	0.00	385.00	444.60
86.68	52.30	0.76	7.66	0.00	412.50	473.22
86.83	52.30	1.03	8.50	0.00	440.00	501.84
86.98	52.30	1.30	9.35	0.00	440.00	502.96
87.13	52.30	1.57	10.20	0.00	440.00	504.07
87.28	52.30	1.84	11.05	0.00	440.00	505.19
87.43	52.30	2.11	11.90	0.00	440.00	506.31
87.58	52.30	2.38	12.75	0.00	440.00	507.43
87.73	52.30	2.65	13.59	0.00	440.00	508.55
87.88	52.30	2.92	14.44	0.00	440.00	509.67
87.98	52.30	3.10	15.01	0.00	440.00	510.41
88.10	52.30	3.32	15.69	0.00	440.00	511.31
88.13	52.30	3.37	15.86	0.00	440.00	511.53
88.18	52.30	3.46	16.14	0.00	440.00	511.90
88.22	52.30	3.54	16.37	0.00	440.00	512.20
88.30	52.30	3.68	16.82	0.00	440.00	512.80

Water Level (m)	Flow Through Orifice (cms)
84.43	0.000
84.58	0.001
84.73	0.002
84.88	0.002
85.03	0.003
85.18	0.003
85.33	0.003
85.48	0.004
85.63	0.004
85.78	0.004
85.93	0.004
86.08	0.004
86.23	0.005
86.38	0.005
86.53	0.005
86.68	0.005
86.83	0.005
86.98	0.005
87.13	0.006
87.28	0.006
87.43	0.006
87.58	0.006
87.73	0.006
87.88	0.006
87.98	0.006
88.10	0.007
88.13	0.007
88.18	0.007
88.22	0.007
88.30	0.007

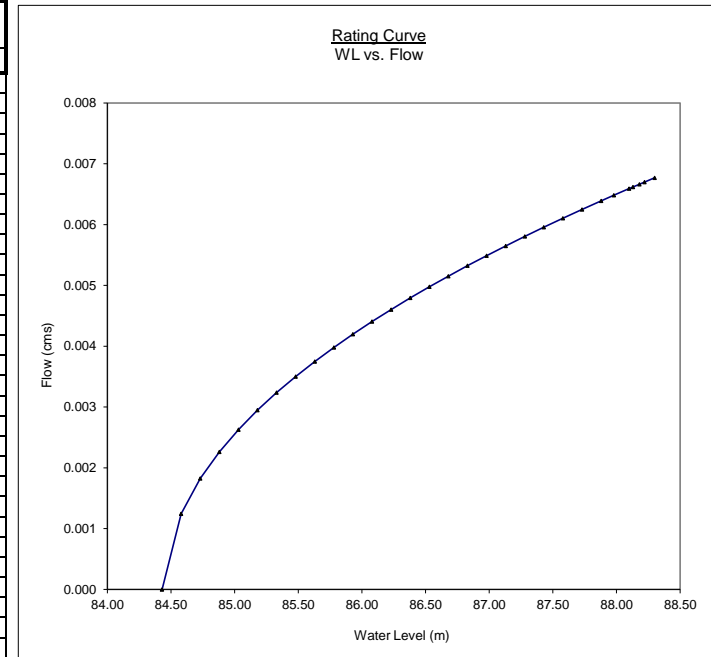

25mm STORM - PRE-DEVELOPMENT



1

NHYD - 1

AREA [ha] - 0.751

PKFW [m³/s] - 0.073

=====

V V I SSSSS U U A L (v 6.2.2005)
V V I SS U U A A L
V V I SS U U AAAAA L
V V I SS U U A A L
WV I SSSSS UUUUU A A LLLLL

000 TTTTT TTTTT H H Y Y M M 000 TM
0 0 T T H H Y Y MM MM 0 0
0 0 T T H H Y M M 0 0
000 T T H H Y M M 000

Developed and Distributed by Smart City Water Inc
Copyright 2007 - 2021 Smart City Water Inc
All rights reserved.

***** D E T A I L E D O U T P U T *****

Input filename: C:\Program Files (x86)\Visual OTTHYMO 6.2\V02\voin.dat

Output filename:

C:\Users\LiMing\AppData\Local\Civica\VH5\90c30b05-cee4-4f42-8939-ca4273b1ea06\c377866e-c023-41ad-98d2-b0691b470ae7\scena

Summary filename:

C:\Users\LiMing\AppData\Local\Civica\VH5\90c30b05-cee4-4f42-8939-ca4273b1ea06\c377866e-c023-41ad-98d2-b0691b470ae7\scena

DATE: 09/24/2021

TIME: 04:44:00

USER:

COMMENTS: _____

** SIMULATION : 25mm **

| READ STORM | Filename: C:\Users\LiMing\AppData\Local\Temp\

| Ptotal= 25.00 mm |

21989db7-ca35-4944-963d-59362778e084\b2416f6e
 Comments: 25mm 4hr Chicago

TIME	RAIN	TIME	RAIN	TIME	RAIN	TIME	RAIN
hrs	mm/hr	hrs	mm/hr	hrs	mm/hr	hrs	mm/hr
0.17	2.07	1.17	5.70	2.17	5.19	3.17	2.80
0.33	2.27	1.33	10.78	2.33	4.47	3.33	2.62
0.50	2.52	1.50	50.21	2.50	3.95	3.50	2.48
0.67	2.88	1.67	13.37	2.67	3.56	3.67	2.35
0.83	3.38	1.83	8.29	2.83	3.25	3.83	2.23
1.00	4.18	2.00	6.30	3.00	3.01	4.00	2.14

| CALIB
 | STANDHYD (0001)
 | ID= 1 DT= 5.0 min |

Area (ha)= 0.75
 Total Imp(%)= 70.20 Dir. Conn.(%)= 70.20

	IMPERVIOUS	PERVIOUS (i)
Surface Area (ha)=	0.53	0.22
Dep. Storage (mm)=	1.00	1.50
Average Slope (%)=	1.00	2.00
Length (m)=	70.76	40.00
Mannings n =	0.013	0.250

NOTE: RAINFALL WAS TRANSFORMED TO 5.0 MIN. TIME STEP.

----- TRANSFORMED HYETOGRAPH -----

TIME	RAIN	TIME	RAIN	TIME	RAIN	TIME	RAIN
hrs	mm/hr	hrs	mm/hr	hrs	mm/hr	hrs	mm/hr
0.083	2.07	1.083	5.70	2.083	5.19	3.08	2.80
0.167	2.07	1.167	5.70	2.167	5.19	3.17	2.80
0.250	2.27	1.250	10.78	2.250	4.47	3.25	2.62
0.333	2.27	1.333	10.78	2.333	4.47	3.33	2.62
0.417	2.52	1.417	50.21	2.417	3.95	3.42	2.48
0.500	2.52	1.500	50.21	2.500	3.95	3.50	2.48
0.583	2.88	1.583	13.37	2.583	3.56	3.58	2.35
0.667	2.88	1.667	13.37	2.667	3.56	3.67	2.35
0.750	3.38	1.750	8.29	2.750	3.25	3.75	2.23
0.833	3.38	1.833	8.29	2.833	3.25	3.83	2.23
0.917	4.17	1.917	6.30	2.917	3.01	3.92	2.14
1.000	4.18	2.000	6.29	3.000	3.01	4.00	2.14

Max.Eff.Inten.(mm/hr)=	50.21	9.88
over (min)	5.00	25.00
Storage Coeff. (min)=	2.73 (ii)	20.55 (ii)
Unit Hyd. Tpeak (min)=	5.00	25.00
Unit Hyd. peak (cms)=	0.29	0.05

				TOTALS
PEAK FLOW	(cms)=	0.07	0.00	0.073 (iii)
TIME TO PEAK	(hrs)=	1.50	1.83	1.50
RUNOFF VOLUME	(mm)=	24.00	8.08	19.24
TOTAL RAINFALL	(mm)=	25.00	25.00	25.00
RUNOFF COEFFICIENT	=	0.96	0.32	0.77

***** WARNING: STORAGE COEFF. IS SMALLER THAN TIME STEP!

- (i) CN PROCEDURE SELECTED FOR PERVIOUS LOSSES:
CN* = 85.0 Ia = Dep. Storage (Above)
- (ii) TIME STEP (DT) SHOULD BE SMALLER OR EQUAL
THAN THE STORAGE COEFFICIENT.
- (iii) PEAK FLOW DOES NOT INCLUDE BASEFLOW IF ANY.

FINISH
=====

2-YR STORM - PRE-DEVELOPMENT



1

NHYD - 1

AREA [ha] - 0.751

PKFW [m³/s] - 0.114

=====

V V I SSSSS U U A L (v 6.2.2005)
V V I SS U U A A L
V V I SS U U AAAAA L
V V I SS U U A A L
WV I SSSSS UUUUU A A LLLLL

000 TTTTT TTTTT H H Y Y M M 000 TM
0 0 T T H H Y Y MM MM 0 0
0 0 T T H H Y M M 0 0
000 T T H H Y M M 000

Developed and Distributed by Smart City Water Inc
Copyright 2007 - 2021 Smart City Water Inc
All rights reserved.

***** D E T A I L E D O U T P U T *****

Input filename: C:\Program Files (x86)\Visual OTTHYMO 6.2\V02\voin.dat

Output filename:

C:\Users\LiMing\AppData\Local\Civica\VH5\90c30b05-cee4-4f42-8939-ca4273b1ea06\90a57d32-7c03-4937-9237-45056ebfb28f\scena

Summary filename:

C:\Users\LiMing\AppData\Local\Civica\VH5\90c30b05-cee4-4f42-8939-ca4273b1ea06\90a57d32-7c03-4937-9237-45056ebfb28f\scena

DATE: 09/24/2021

TIME: 04:44:00

USER:

COMMENTS: _____

** SIMULATION : 2-yr **

| CHICAGO STORM |
Ptotal= 31.86 mm

IDF curve parameters: A= 732.951
B= 6.199
C= 0.810

used in: INTENSITY = A / (t + B)^C

Duration of storm = 3.00 hrs
 Storm time step = 10.00 min
 Time to peak ratio = 0.33

TIME	RAIN	TIME	RAIN	TIME	RAIN	TIME	RAIN
hrs	mm/hr	hrs	mm/hr	hrs	mm/hr	hrs	mm/hr
0.17	2.81	1.00	76.81	1.83	5.09	2.67	2.68
0.33	3.50	1.17	24.08	2.00	4.29	2.83	2.46
0.50	4.69	1.33	12.36	2.17	3.72	3.00	2.28
0.67	7.30	1.50	8.32	2.33	3.29		
0.83	18.21	1.67	6.30	2.50	2.95		

```

-----
| CALIB          |
| STANDHYD ( 0001) |
| ID= 1 DT= 5.0 min |
-----
  
```

Area (ha)= 0.75
 Total Imp(%)= 70.20 Dir. Conn.(%)= 70.20

	IMPERVIOUS	PERVIOUS (i)
Surface Area (ha)=	0.53	0.22
Dep. Storage (mm)=	1.00	1.50
Average Slope (%)=	1.00	2.00
Length (m)=	70.76	40.00
Mannings n =	0.013	0.250

NOTE: RAINFALL WAS TRANSFORMED TO 5.0 MIN. TIME STEP.

----- TRANSFORMED HYETOGRAPH -----

TIME	RAIN	TIME	RAIN	TIME	RAIN	TIME	RAIN
hrs	mm/hr	hrs	mm/hr	hrs	mm/hr	hrs	mm/hr
0.083	2.81	0.833	18.21	1.583	6.30	2.33	3.29
0.167	2.81	0.917	76.80	1.667	6.30	2.42	2.95
0.250	3.50	1.000	76.81	1.750	5.09	2.50	2.95
0.333	3.50	1.083	24.08	1.833	5.09	2.58	2.68
0.417	4.69	1.167	24.08	1.917	4.29	2.67	2.68
0.500	4.69	1.250	12.36	2.000	4.29	2.75	2.46
0.583	7.30	1.333	12.36	2.083	3.72	2.83	2.46
0.667	7.30	1.417	8.32	2.167	3.72	2.92	2.28
0.750	18.21	1.500	8.32	2.250	3.29	3.00	2.28

Max.Eff.Inten.(mm/hr)=	76.81	21.72
over (min)	5.00	20.00
Storage Coeff. (min)=	2.31 (ii)	15.31 (ii)
Unit Hyd. Tpeak (min)=	5.00	20.00
Unit Hyd. peak (cms)=	0.30	0.07

TOTALS

PEAK FLOW	(cms)=	0.11	0.01	0.114 (iii)
TIME TO PEAK	(hrs)=	1.00	1.25	1.00
RUNOFF VOLUME	(mm)=	30.86	12.26	25.30
TOTAL RAINFALL	(mm)=	31.86	31.86	31.86
RUNOFF COEFFICIENT	=	0.97	0.38	0.79

***** WARNING: STORAGE COEFF. IS SMALLER THAN TIME STEP!

- (i) CN PROCEDURE SELECTED FOR PERVIOUS LOSSES:
CN* = 85.0 Ia = Dep. Storage (Above)
- (ii) TIME STEP (DT) SHOULD BE SMALLER OR EQUAL
THAN THE STORAGE COEFFICIENT.
- (iii) PEAK FLOW DOES NOT INCLUDE BASEFLOW IF ANY.

100-YR STORM - PRE-DEVELOPMENT



1

NHYD - 1

AREA [ha] - 0.751

PKFW [m³/s] - 0.306

=====

V V I SSSSS U U A L (v 6.2.2005)
V V I SS U U A A L
V V I SS U U AAAAA L
V V I SS U U A A L
WV I SSSSS UUUUU A A LLLLL

000 TTTT TTTT H H Y Y M M 000 TM
0 0 T T H H Y Y MM MM 0 0
0 0 T T H H Y M M 0 0
000 T T H H Y M M 000

Developed and Distributed by Smart City Water Inc
Copyright 2007 - 2021 Smart City Water Inc
All rights reserved.

***** D E T A I L E D O U T P U T *****

Input filename: C:\Program Files (x86)\Visual OTTHYMO 6.2\V02\voin.dat

Output filename:

C:\Users\LiMing\AppData\Local\Civica\VH5\90c30b05-cee4-4f42-8939-ca4273b1ea06\5cfac042-1bd7-47be-b0ad-47a6f4486514\scena

Summary filename:

C:\Users\LiMing\AppData\Local\Civica\VH5\90c30b05-cee4-4f42-8939-ca4273b1ea06\5cfac042-1bd7-47be-b0ad-47a6f4486514\scena

DATE: 09/24/2021

TIME: 04:43:59

USER:

COMMENTS: _____

** SIMULATION : 100-yr **

| CHICAGO STORM |
Ptotal= 71.66 mm

IDF curve parameters: A=1735.688
B= 6.014
C= 0.820

used in: INTENSITY = A / (t + B)^C

Duration of storm = 3.00 hrs
 Storm time step = 10.00 min
 Time to peak ratio = 0.33

TIME	RAIN	TIME	RAIN	TIME	RAIN	TIME	RAIN
hrs	mm/hr	hrs	mm/hr	hrs	mm/hr	hrs	mm/hr
0.17	6.05	1.00	178.56	1.83	11.06	2.67	5.76
0.33	7.54	1.17	54.05	2.00	9.29	2.83	5.28
0.50	10.16	1.33	27.32	2.17	8.02	3.00	4.88
0.67	15.97	1.50	18.24	2.33	7.08		
0.83	40.65	1.67	13.74	2.50	6.35		

```

-----
| CALIB          |
| STANDHYD ( 0001) |
| ID= 1 DT= 5.0 min |
-----
  
```

Area (ha)= 0.75
 Total Imp(%)= 70.20 Dir. Conn.(%)= 70.20

	IMPERVIOUS	PERVIOUS (i)
Surface Area (ha)=	0.53	0.22
Dep. Storage (mm)=	1.00	1.50
Average Slope (%)=	1.00	2.00
Length (m)=	70.76	40.00
Mannings n =	0.013	0.250

NOTE: RAINFALL WAS TRANSFORMED TO 5.0 MIN. TIME STEP.

----- TRANSFORMED HYETOGRAPH -----

TIME	RAIN	TIME	RAIN	TIME	RAIN	TIME	RAIN
hrs	mm/hr	hrs	mm/hr	hrs	mm/hr	hrs	mm/hr
0.083	6.05	0.833	40.65	1.583	13.74	2.33	7.08
0.167	6.05	0.917	178.56	1.667	13.74	2.42	6.35
0.250	7.54	1.000	178.56	1.750	11.06	2.50	6.35
0.333	7.54	1.083	54.05	1.833	11.06	2.58	5.76
0.417	10.16	1.167	54.05	1.917	9.29	2.67	5.76
0.500	10.16	1.250	27.32	2.000	9.29	2.75	5.28
0.583	15.97	1.333	27.32	2.083	8.02	2.83	5.28
0.667	15.97	1.417	18.24	2.167	8.02	2.92	4.88
0.750	40.65	1.500	18.24	2.250	7.08	3.00	4.88

Max.Eff.Inten.(mm/hr)=	178.56	105.42
over (min)	5.00	10.00
Storage Coeff. (min)=	1.65 (ii)	5.62 (ii)
Unit Hyd. Tpeak (min)=	5.00	10.00
Unit Hyd. peak (cms)=	0.32	0.15

TOTALS

PEAK FLOW	(cms)=	0.26	0.05	0.306 (iii)
TIME TO PEAK	(hrs)=	1.00	1.08	1.00
RUNOFF VOLUME	(mm)=	70.66	42.81	62.36
TOTAL RAINFALL	(mm)=	71.66	71.66	71.66
RUNOFF COEFFICIENT	=	0.99	0.60	0.87

***** WARNING: STORAGE COEFF. IS SMALLER THAN TIME STEP!

- (i) CN PROCEDURE SELECTED FOR PERVIOUS LOSSES:
CN* = 85.0 Ia = Dep. Storage (Above)
- (ii) TIME STEP (DT) SHOULD BE SMALLER OR EQUAL
THAN THE STORAGE COEFFICIENT.
- (iii) PEAK FLOW DOES NOT INCLUDE BASEFLOW IF ANY.

25mm 4hr STORM POST DEVELOPMENT UNCONTROLLED

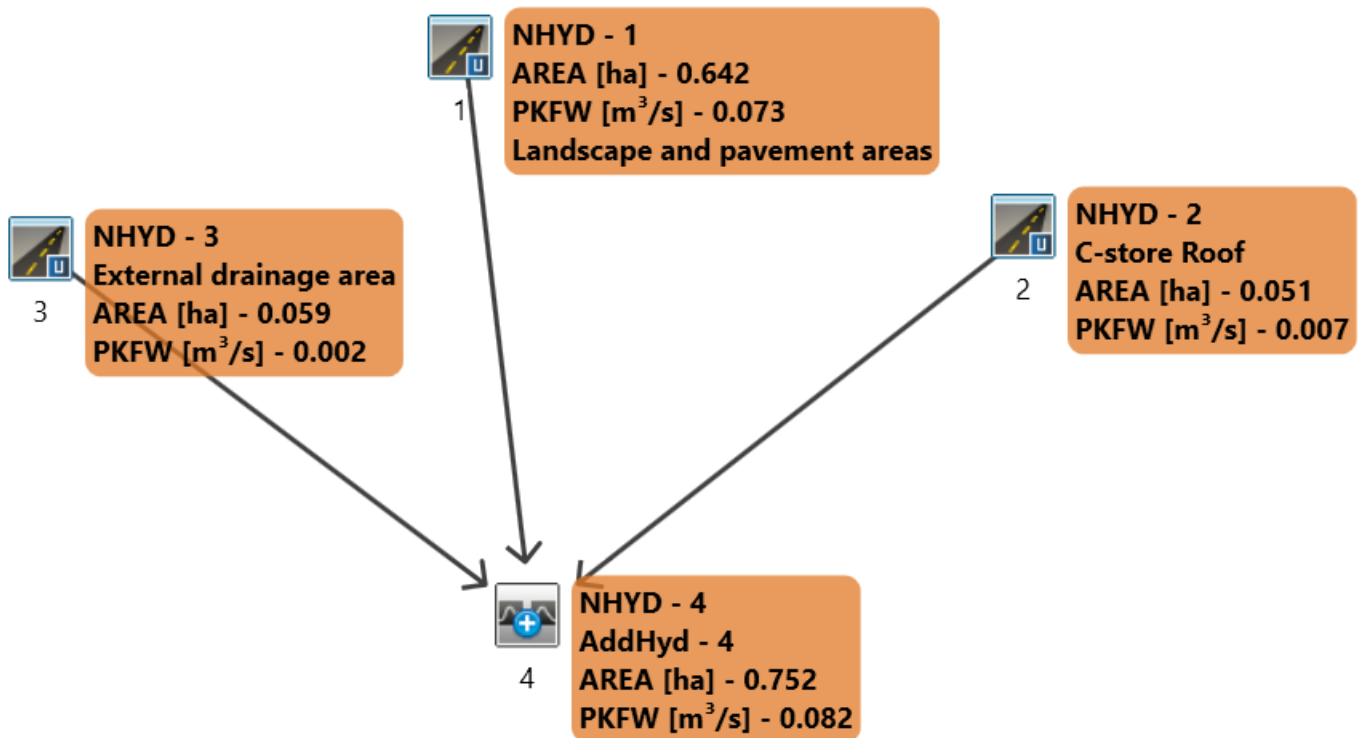

=====

V V I SSSSS U U A L (v 6.2.2005)
V V I SS U U A A L
V V I SS U U AAAAA L
V V I SS U U A A L
WV I SSSSS UUUUU A A LLLLL

000 TTTTT TTTTT H H Y Y M M 000 TM
0 0 T T H H Y Y MM MM 0 0
0 0 T T H H Y M M 0 0
000 T T H H Y M M 000

Developed and Distributed by Smart City Water Inc
Copyright 2007 - 2021 Smart City Water Inc
All rights reserved.

***** D E T A I L E D O U T P U T *****

Input filename: C:\Program Files (x86)\Visual OTTHYMO 6.2\V02\voin.dat

Output filename:

C:\Users\LiMing\AppData\Local\Civica\VH5\90c30b05-cee4-4f42-8939-ca4273b1ea06\f478e2de-b648-4d7e-b7b3-5b9c11948ab8\scena

Summary filename:

C:\Users\LiMing\AppData\Local\Civica\VH5\90c30b05-cee4-4f42-8939-ca4273b1ea06\f478e2de-b648-4d7e-b7b3-5b9c11948ab8\scena

DATE: 09/24/2021

TIME: 04:51:08

USER:

COMMENTS: _____

** SIMULATION : 25mm 4hr Chicago **

| READ STORM |
|

Filename: C:\Users\LiMing\AppData\Local\Temp\

| Ptotal= 25.00 mm |

089dc6c2-a59d-49c7-a793-32cc9c0b761d\b2416f6e
 Comments: 25mm 4hr Chicago

TIME	RAIN	TIME	RAIN	TIME	RAIN	TIME	RAIN
hrs	mm/hr	hrs	mm/hr	hrs	mm/hr	hrs	mm/hr
0.17	2.07	1.17	5.70	2.17	5.19	3.17	2.80
0.33	2.27	1.33	10.78	2.33	4.47	3.33	2.62
0.50	2.52	1.50	50.21	2.50	3.95	3.50	2.48
0.67	2.88	1.67	13.37	2.67	3.56	3.67	2.35
0.83	3.38	1.83	8.29	2.83	3.25	3.83	2.23
1.00	4.18	2.00	6.30	3.00	3.01	4.00	2.14

| CALIB
 | STANDHYD (0001)
 | ID= 1 DT= 5.0 min |

Area (ha)= 0.64
 Total Imp(%)= 82.40 Dir. Conn.(%)= 82.40

	IMPERVIOUS	PERVIOUS (i)
Surface Area (ha)=	0.53	0.11
Dep. Storage (mm)=	1.00	1.50
Average Slope (%)=	1.00	2.00
Length (m)=	65.42	40.00
Mannings n =	0.013	0.250

NOTE: RAINFALL WAS TRANSFORMED TO 5.0 MIN. TIME STEP.

----- TRANSFORMED HYETOGRAPH -----

TIME	RAIN	TIME	RAIN	TIME	RAIN	TIME	RAIN
hrs	mm/hr	hrs	mm/hr	hrs	mm/hr	hrs	mm/hr
0.083	2.07	1.083	5.70	2.083	5.19	3.08	2.80
0.167	2.07	1.167	5.70	2.167	5.19	3.17	2.80
0.250	2.27	1.250	10.78	2.250	4.47	3.25	2.62
0.333	2.27	1.333	10.78	2.333	4.47	3.33	2.62
0.417	2.52	1.417	50.21	2.417	3.95	3.42	2.48
0.500	2.52	1.500	50.21	2.500	3.95	3.50	2.48
0.583	2.88	1.583	13.37	2.583	3.56	3.58	2.35
0.667	2.88	1.667	13.37	2.667	3.56	3.67	2.35
0.750	3.38	1.750	8.29	2.750	3.25	3.75	2.23
0.833	3.38	1.833	8.29	2.833	3.25	3.83	2.23
0.917	4.17	1.917	6.30	2.917	3.01	3.92	2.14
1.000	4.18	2.000	6.29	3.000	3.01	4.00	2.14

Max.Eff.Inten.(mm/hr)=	50.21	9.88
over (min)	5.00	25.00
Storage Coeff. (min)=	2.61 (ii)	20.42 (ii)
Unit Hyd. Tpeak (min)=	5.00	25.00
Unit Hyd. peak (cms)=	0.29	0.05

				TOTALS
PEAK FLOW	(cms)=	0.07	0.00	0.073 (iii)
TIME TO PEAK	(hrs)=	1.50	1.83	1.50
RUNOFF VOLUME	(mm)=	24.00	8.08	21.18
TOTAL RAINFALL	(mm)=	25.00	25.00	25.00
RUNOFF COEFFICIENT	=	0.96	0.32	0.85

***** WARNING: STORAGE COEFF. IS SMALLER THAN TIME STEP!

- (i) CN PROCEDURE SELECTED FOR PERVIOUS LOSSES:
CN* = 85.0 Ia = Dep. Storage (Above)
- (ii) TIME STEP (DT) SHOULD BE SMALLER OR EQUAL
THAN THE STORAGE COEFFICIENT.
- (iii) PEAK FLOW DOES NOT INCLUDE BASEFLOW IF ANY.

```

-----
| CALIB |
| STANDHYD ( 0002) |
| ID= 1 DT=5.0 min |
-----
Area (ha)= 0.05
Total Imp(%)= 99.00 Dir. Conn.(%)= 99.00

```

		IMPERVIOUS	PERVIOUS (i)
Surface Area	(ha)=	0.05	0.00
Dep. Storage	(mm)=	1.00	1.50
Average Slope	(%)=	1.00	2.00
Length	(m)=	18.44	40.00
Mannings n	=	0.013	0.250

NOTE: RAINFALL WAS TRANSFORMED TO 5.0 MIN. TIME STEP.

```

----- TRANSFORMED HYETOGRAPH -----
TIME RAIN | TIME RAIN | TIME RAIN | TIME RAIN
hrs mm/hr | hrs mm/hr | hrs mm/hr | hrs mm/hr
0.083 2.07 | 1.083 5.70 | 2.083 5.19 | 3.08 2.80
0.167 2.07 | 1.167 5.70 | 2.167 5.19 | 3.17 2.80
0.250 2.27 | 1.250 10.78 | 2.250 4.47 | 3.25 2.62
0.333 2.27 | 1.333 10.78 | 2.333 4.47 | 3.33 2.62
0.417 2.52 | 1.417 50.21 | 2.417 3.95 | 3.42 2.48
0.500 2.52 | 1.500 50.21 | 2.500 3.95 | 3.50 2.48
0.583 2.88 | 1.583 13.37 | 2.583 3.56 | 3.58 2.35
0.667 2.88 | 1.667 13.37 | 2.667 3.56 | 3.67 2.35
0.750 3.38 | 1.750 8.29 | 2.750 3.25 | 3.75 2.23
0.833 3.38 | 1.833 8.29 | 2.833 3.25 | 3.83 2.23
0.917 4.17 | 1.917 6.30 | 2.917 3.01 | 3.92 2.14
1.000 4.18 | 2.000 6.29 | 3.000 3.01 | 4.00 2.14

```

Max.Eff.Inten.(mm/hr)=	50.21	14.26
over (min)	5.00	5.00
Storage Coeff. (min)=	1.22 (ii)	2.70 (ii)

Unit Hyd. Tpeak (min)=	5.00	5.00	
Unit Hyd. peak (cms)=	0.33	0.29	
			TOTALS
PEAK FLOW (cms)=	0.01	0.00	0.007 (iii)
TIME TO PEAK (hrs)=	1.50	1.50	1.50
RUNOFF VOLUME (mm)=	24.00	8.08	23.83
TOTAL RAINFALL (mm)=	25.00	25.00	25.00
RUNOFF COEFFICIENT =	0.96	0.32	0.95

***** WARNING: STORAGE COEFF. IS SMALLER THAN TIME STEP!

- (i) CN PROCEDURE SELECTED FOR PERVIOUS LOSSES:
CN* = 85.0 Ia = Dep. Storage (Above)
- (ii) TIME STEP (DT) SHOULD BE SMALLER OR EQUAL THAN THE STORAGE COEFFICIENT.
- (iii) PEAK FLOW DOES NOT INCLUDE BASEFLOW IF ANY.

CALIB	
STANDHYD (0003)	Area (ha)= 0.06
ID= 1 DT= 5.0 min	Total Imp(%)= 23.50 Dir. Conn.(%)= 23.50

		IMPERVIOUS	PERVIOUS (i)
Surface Area	(ha)=	0.01	0.05
Dep. Storage	(mm)=	1.00	1.50
Average Slope	(%)=	1.00	2.00
Length	(m)=	19.83	40.00
Mannings n	=	0.013	0.250

NOTE: RAINFALL WAS TRANSFORMED TO 5.0 MIN. TIME STEP.

----- TRANSFORMED HYETOGRAPH -----

TIME	RAIN	TIME	RAIN	TIME	RAIN	TIME	RAIN
hrs	mm/hr	hrs	mm/hr	hrs	mm/hr	hrs	mm/hr
0.083	2.07	1.083	5.70	2.083	5.19	3.08	2.80
0.167	2.07	1.167	5.70	2.167	5.19	3.17	2.80
0.250	2.27	1.250	10.78	2.250	4.47	3.25	2.62
0.333	2.27	1.333	10.78	2.333	4.47	3.33	2.62
0.417	2.52	1.417	50.21	2.417	3.95	3.42	2.48
0.500	2.52	1.500	50.21	2.500	3.95	3.50	2.48
0.583	2.88	1.583	13.37	2.583	3.56	3.58	2.35
0.667	2.88	1.667	13.37	2.667	3.56	3.67	2.35
0.750	3.38	1.750	8.29	2.750	3.25	3.75	2.23
0.833	3.38	1.833	8.29	2.833	3.25	3.83	2.23
0.917	4.17	1.917	6.30	2.917	3.01	3.92	2.14
1.000	4.18	2.000	6.29	3.000	3.01	4.00	2.14

Max. Eff. Inten. (mm/hr)=	50.21	9.88
---------------------------	-------	------

over (min)	5.00	20.00	
Storage Coeff. (min)=	1.27 (ii)	19.09 (ii)	
Unit Hyd. Tpeak (min)=	5.00	20.00	
Unit Hyd. peak (cms)=	0.33	0.06	
			TOTALS
PEAK FLOW (cms)=	0.00	0.00	0.002 (iii)
TIME TO PEAK (hrs)=	1.50	1.75	1.50
RUNOFF VOLUME (mm)=	24.00	8.08	11.62
TOTAL RAINFALL (mm)=	25.00	25.00	25.00
RUNOFF COEFFICIENT =	0.96	0.32	0.46

***** WARNING: STORAGE COEFF. IS SMALLER THAN TIME STEP!

- (i) CN PROCEDURE SELECTED FOR PERVIOUS LOSSES:
CN* = 85.0 Ia = Dep. Storage (Above)
- (ii) TIME STEP (DT) SHOULD BE SMALLER OR EQUAL
THAN THE STORAGE COEFFICIENT.
- (iii) PEAK FLOW DOES NOT INCLUDE BASEFLOW IF ANY.

ADD HYD (0004)				
1 + 2 = 3	AREA	QPEAK	TPEAK	R.V.
	(ha)	(cms)	(hrs)	(mm)
ID1= 1 (0001):	0.64	0.073	1.50	21.18
+ ID2= 2 (0002):	0.05	0.007	1.50	23.83
=====				
ID = 3 (0004):	0.69	0.080	1.50	21.37

NOTE: PEAK FLOWS DO NOT INCLUDE BASEFLOWS IF ANY.

ADD HYD (0004)				
3 + 2 = 1	AREA	QPEAK	TPEAK	R.V.
	(ha)	(cms)	(hrs)	(mm)
ID1= 3 (0004):	0.69	0.080	1.50	21.37
+ ID2= 2 (0003):	0.06	0.002	1.50	11.62
=====				
ID = 1 (0004):	0.75	0.082	1.50	20.61

NOTE: PEAK FLOWS DO NOT INCLUDE BASEFLOWS IF ANY.

FINISH

=====

=====

2-YR STORM POST DEVELOPMENT UNCONTROLLED

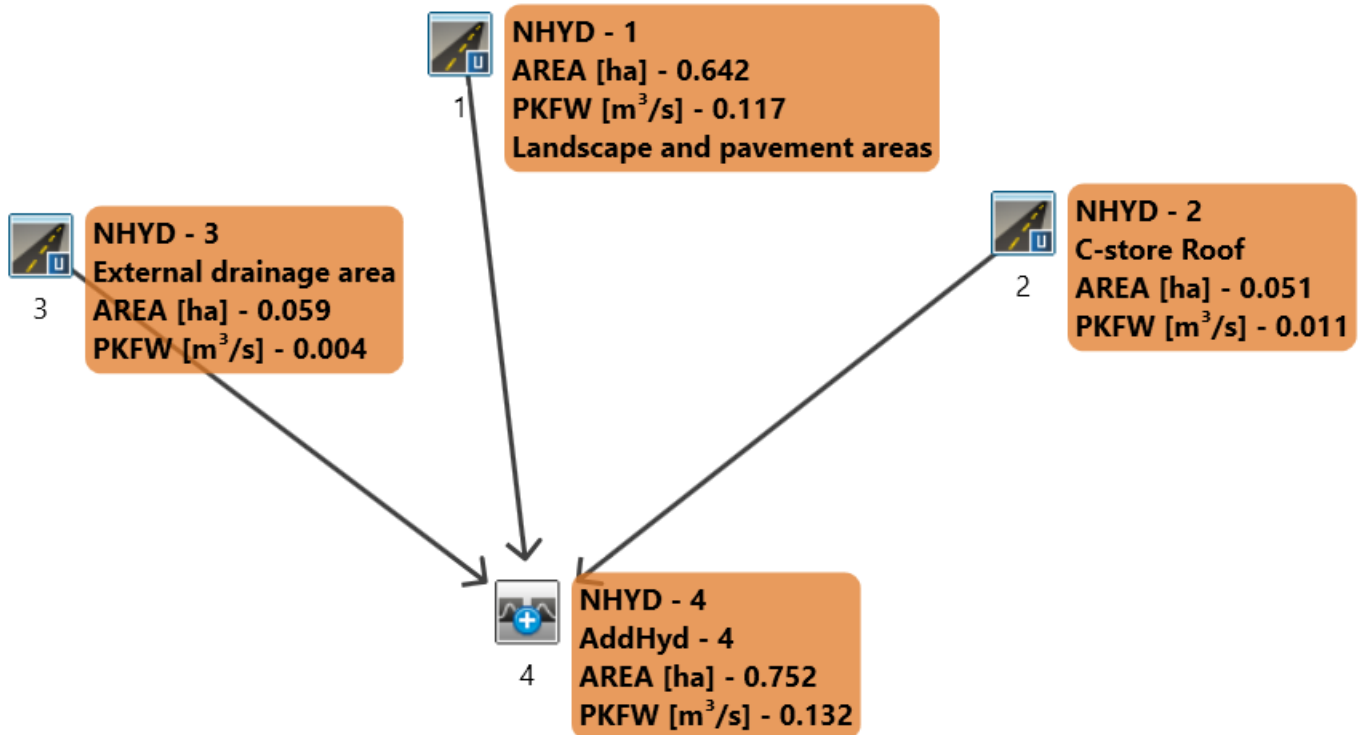

=====

V V I SSSSS U U A L (v 6.2.2005)
V V I SS U U A A L
V V I SS U U AAAAA L
V V I SS U U A A L
WV I SSSSS UUUUU A A LLLLL

000 TTTT TTTT H H Y Y M M 000 TM
0 0 T T H H Y Y MM MM 0 0
0 0 T T H H Y M M 0 0
000 T T H H Y M M 000

Developed and Distributed by Smart City Water Inc
Copyright 2007 - 2021 Smart City Water Inc
All rights reserved.

***** D E T A I L E D O U T P U T *****

Input filename: C:\Program Files (x86)\Visual OTTHYMO 6.2\V02\voin.dat

Output filename:

C:\Users\LiMing\AppData\Local\Civica\VH5\90c30b05-cee4-4f42-8939-ca4273b1ea06\66e20828-165a-4198-bca9-7ab1396f4514\scena

Summary filename:

C:\Users\LiMing\AppData\Local\Civica\VH5\90c30b05-cee4-4f42-8939-ca4273b1ea06\66e20828-165a-4198-bca9-7ab1396f4514\scena

DATE: 08/17/2021

TIME: 06:04:30

USER:

COMMENTS: _____

** SIMULATION : Chicago Design Storm - 2yr **

| CHICAGO STORM |
Ptotal= 31.86 mm

IDF curve parameters: A= 732.951
B= 6.199
C= 0.810

used in: INTENSITY = A / (t + B)^C

Duration of storm = 3.00 hrs
 Storm time step = 10.00 min
 Time to peak ratio = 0.33

TIME	RAIN	TIME	RAIN	TIME	RAIN	TIME	RAIN
hrs	mm/hr	hrs	mm/hr	hrs	mm/hr	hrs	mm/hr
0.17	2.81	1.00	76.81	1.83	5.09	2.67	2.68
0.33	3.50	1.17	24.08	2.00	4.29	2.83	2.46
0.50	4.69	1.33	12.36	2.17	3.72	3.00	2.28
0.67	7.30	1.50	8.32	2.33	3.29		
0.83	18.21	1.67	6.30	2.50	2.95		

```

-----
| CALIB          |
| STANDHYD ( 0001) |
| ID= 1 DT= 5.0 min |
-----
  
```

Area (ha)= 0.64
 Total Imp(%)= 82.40 Dir. Conn.(%)= 82.40

	IMPERVIOUS	PERVIOUS (i)
Surface Area (ha)=	0.53	0.11
Dep. Storage (mm)=	1.00	1.50
Average Slope (%)=	1.00	2.00
Length (m)=	65.42	40.00
Mannings n =	0.013	0.250

NOTE: RAINFALL WAS TRANSFORMED TO 5.0 MIN. TIME STEP.

----- TRANSFORMED HYETOGRAPH -----

TIME	RAIN	TIME	RAIN	TIME	RAIN	TIME	RAIN
hrs	mm/hr	hrs	mm/hr	hrs	mm/hr	hrs	mm/hr
0.083	2.81	0.833	18.21	1.583	6.30	2.33	3.29
0.167	2.81	0.917	76.80	1.667	6.30	2.42	2.95
0.250	3.50	1.000	76.81	1.750	5.09	2.50	2.95
0.333	3.50	1.083	24.08	1.833	5.09	2.58	2.68
0.417	4.69	1.167	24.08	1.917	4.29	2.67	2.68
0.500	4.69	1.250	12.36	2.000	4.29	2.75	2.46
0.583	7.30	1.333	12.36	2.083	3.72	2.83	2.46
0.667	7.30	1.417	8.32	2.167	3.72	2.92	2.28
0.750	18.21	1.500	8.32	2.250	3.29	3.00	2.28

Max.Eff.Inten.(mm/hr)=	76.81	26.60
over (min)	5.00	10.00
Storage Coeff. (min)=	2.20 (ii)	6.43 (ii)
Unit Hyd. Tpeak (min)=	5.00	10.00
Unit Hyd. peak (cms)=	0.30	0.14

TOTALS

PEAK FLOW	(cms)=	0.11	0.01	0.117 (iii)
TIME TO PEAK	(hrs)=	1.00	1.08	1.00
RUNOFF VOLUME	(mm)=	30.86	12.26	27.58
TOTAL RAINFALL	(mm)=	31.86	31.86	31.86
RUNOFF COEFFICIENT	=	0.97	0.38	0.87

***** WARNING: STORAGE COEFF. IS SMALLER THAN TIME STEP!

- (i) CN PROCEDURE SELECTED FOR PERVIOUS LOSSES:
CN* = 85.0 Ia = Dep. Storage (Above)
- (ii) TIME STEP (DT) SHOULD BE SMALLER OR EQUAL
THAN THE STORAGE COEFFICIENT.
- (iii) PEAK FLOW DOES NOT INCLUDE BASEFLOW IF ANY.

```

-----
| CALIB |
| STANDHYD ( 0002) | Area (ha)= 0.05
| ID= 1 DT= 5.0 min | Total Imp(%)= 99.00 Dir. Conn.(%)= 99.00
-----

```

		IMPERVIOUS	PERVIOUS (i)
Surface Area	(ha)=	0.05	0.00
Dep. Storage	(mm)=	1.00	1.50
Average Slope	(%)=	1.00	2.00
Length	(m)=	18.44	40.00
Mannings n	=	0.013	0.250

NOTE: RAINFALL WAS TRANSFORMED TO 5.0 MIN. TIME STEP.

```

----- TRANSFORMED HYETOGRAPH -----

```

TIME	RAIN	TIME	RAIN	TIME	RAIN	TIME	RAIN
hrs	mm/hr	hrs	mm/hr	hrs	mm/hr	hrs	mm/hr
0.083	2.81	0.833	18.21	1.583	6.30	2.33	3.29
0.167	2.81	0.917	76.80	1.667	6.30	2.42	2.95
0.250	3.50	1.000	76.81	1.750	5.09	2.50	2.95
0.333	3.50	1.083	24.08	1.833	5.09	2.58	2.68
0.417	4.69	1.167	24.08	1.917	4.29	2.67	2.68
0.500	4.69	1.250	12.36	2.000	4.29	2.75	2.46
0.583	7.30	1.333	12.36	2.083	3.72	2.83	2.46
0.667	7.30	1.417	8.32	2.167	3.72	2.92	2.28
0.750	18.21	1.500	8.32	2.250	3.29	3.00	2.28

Max.Eff.Inten.(mm/hr)=	76.81	26.60
over (min)	5.00	5.00
Storage Coeff. (min)=	1.03 (ii)	2.28 (ii)
Unit Hyd. Tpeak (min)=	5.00	5.00
Unit Hyd. peak (cms)=	0.34	0.30

PEAK FLOW	(cms)=	0.01	0.00	*TOTALS*	0.011 (iii)
-----------	--------	------	------	----------	-------------

TIME TO PEAK	(hrs)=	1.00	1.00	1.00
RUNOFF VOLUME	(mm)=	30.86	12.26	30.67
TOTAL RAINFALL	(mm)=	31.86	31.86	31.86
RUNOFF COEFFICIENT	=	0.97	0.38	0.96

***** WARNING: STORAGE COEFF. IS SMALLER THAN TIME STEP!

- (i) CN PROCEDURE SELECTED FOR PERVIOUS LOSSES:
CN* = 85.0 Ia = Dep. Storage (Above)
- (ii) TIME STEP (DT) SHOULD BE SMALLER OR EQUAL THAN THE STORAGE COEFFICIENT.
- (iii) PEAK FLOW DOES NOT INCLUDE BASEFLOW IF ANY.

```

-----
| CALIB |
| STANDHYD ( 0003) | Area (ha)= 0.06
| ID= 1 DT= 5.0 min | Total Imp(%)= 23.50 Dir. Conn.(%)= 23.50
-----

```

		IMPERVIOUS	PERVIOUS (i)
Surface Area	(ha)=	0.01	0.05
Dep. Storage	(mm)=	1.00	1.50
Average Slope	(%)=	1.00	2.00
Length	(m)=	19.83	40.00
Mannings n	=	0.013	0.250

NOTE: RAINFALL WAS TRANSFORMED TO 5.0 MIN. TIME STEP.

```

----- TRANSFORMED HYETOGRAPH -----

```

TIME	RAIN	TIME	RAIN	TIME	RAIN	TIME	RAIN
hrs	mm/hr	hrs	mm/hr	hrs	mm/hr	hrs	mm/hr
0.083	2.81	0.833	18.21	1.583	6.30	2.33	3.29
0.167	2.81	0.917	76.80	1.667	6.30	2.42	2.95
0.250	3.50	1.000	76.81	1.750	5.09	2.50	2.95
0.333	3.50	1.083	24.08	1.833	5.09	2.58	2.68
0.417	4.69	1.167	24.08	1.917	4.29	2.67	2.68
0.500	4.69	1.250	12.36	2.000	4.29	2.75	2.46
0.583	7.30	1.333	12.36	2.083	3.72	2.83	2.46
0.667	7.30	1.417	8.32	2.167	3.72	2.92	2.28
0.750	18.21	1.500	8.32	2.250	3.29	3.00	2.28

Max. Eff. Inten. (mm/hr)=	76.81	21.72
over (min)	5.00	15.00
Storage Coeff. (min)=	1.08 (ii)	14.07 (ii)
Unit Hyd. Tpeak (min)=	5.00	15.00
Unit Hyd. peak (cms)=	0.34	0.08

			TOTALS
PEAK FLOW	(cms)=	0.00	0.00
TIME TO PEAK	(hrs)=	1.00	1.17
			0.004 (iii)
			1.00

RUNOFF VOLUME	(mm)=	30.86	12.26	16.50
TOTAL RAINFALL	(mm)=	31.86	31.86	31.86
RUNOFF COEFFICIENT	=	0.97	0.38	0.52

***** WARNING: STORAGE COEFF. IS SMALLER THAN TIME STEP!

- (i) CN PROCEDURE SELECTED FOR PERVIOUS LOSSES:
CN* = 85.0 Ia = Dep. Storage (Above)
- (ii) TIME STEP (DT) SHOULD BE SMALLER OR EQUAL
THAN THE STORAGE COEFFICIENT.
- (iii) PEAK FLOW DOES NOT INCLUDE BASEFLOW IF ANY.

```

-----
| ADD HYD ( 0004) |
| 1 + 2 = 3 |
-----
          AREA    QPEAK    TPEAK    R.V.
          (ha)    (cms)    (hrs)    (mm)
ID1= 1 ( 0001):  0.64  0.117  1.00  27.58
+ ID2= 2 ( 0002):  0.05  0.011  1.00  30.67
=====
ID = 3 ( 0004):  0.69  0.128  1.00  27.81

```

NOTE: PEAK FLOWS DO NOT INCLUDE BASEFLOWS IF ANY.

```

-----
| ADD HYD ( 0004) |
| 3 + 2 = 1 |
-----
          AREA    QPEAK    TPEAK    R.V.
          (ha)    (cms)    (hrs)    (mm)
ID1= 3 ( 0004):  0.69  0.128  1.00  27.81
+ ID2= 2 ( 0003):  0.06  0.004  1.00  16.50
=====
ID = 1 ( 0004):  0.75  0.132  1.00  26.92

```

NOTE: PEAK FLOWS DO NOT INCLUDE BASEFLOWS IF ANY.

100-YR STORM POST DEVELOPMENT UNCONTROLLED

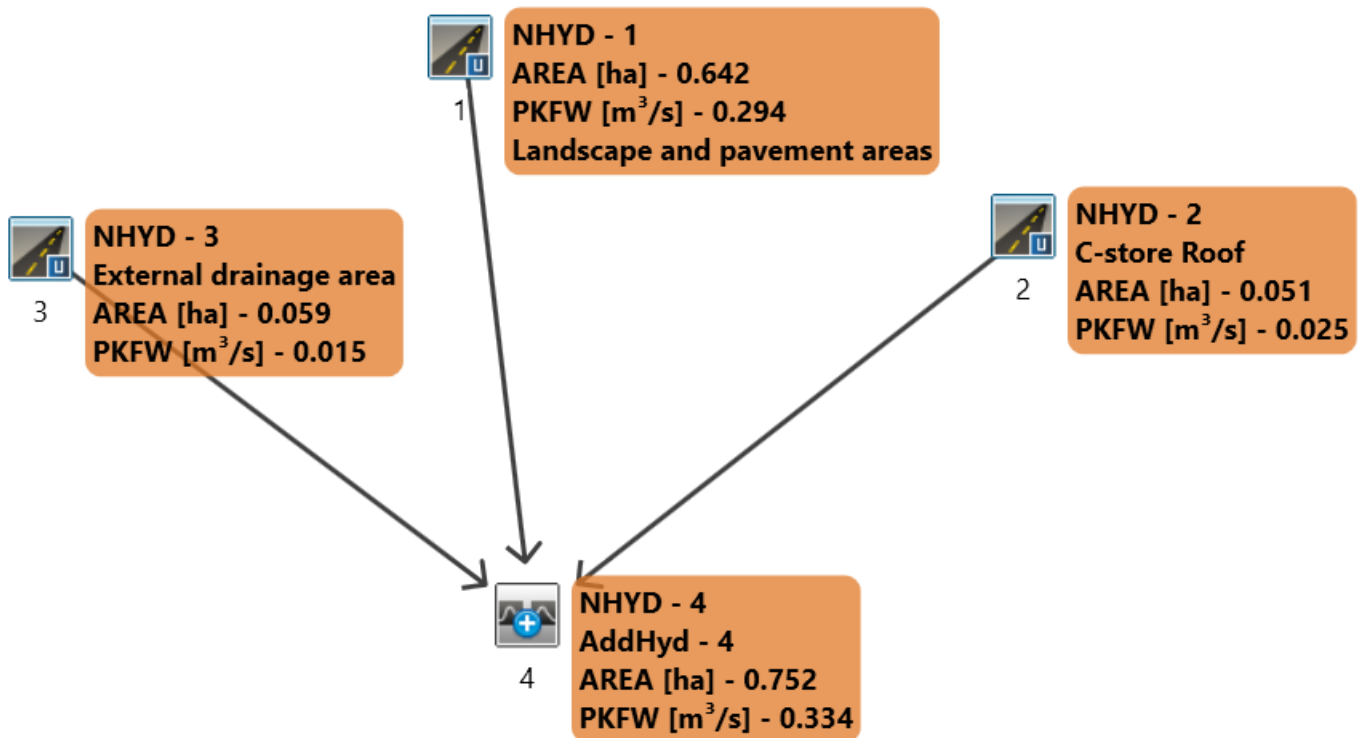

=====

V V I SSSSS U U A L (v 6.2.2005)
V V I SS U U A A L
V V I SS U U AAAAA L
V V I SS U U A A L
WV I SSSSS UUUUU A A LLLLL

000 TTTTT TTTTT H H Y Y M M 000 TM
0 0 T T H H Y Y MM MM 0 0
0 0 T T H H Y M M 0 0
000 T T H H Y M M 000

Developed and Distributed by Smart City Water Inc
Copyright 2007 - 2021 Smart City Water Inc
All rights reserved.

***** D E T A I L E D O U T P U T *****

Input filename: C:\Program Files (x86)\Visual OTTHYMO 6.2\V02\voin.dat

Output filename:

C:\Users\LiMing\AppData\Local\Civica\VH5\90c30b05-cee4-4f42-8939-ca4273b1ea06\3af5704a-e5db-4dec-8637-8b4da3839522\scena

Summary filename:

C:\Users\LiMing\AppData\Local\Civica\VH5\90c30b05-cee4-4f42-8939-ca4273b1ea06\3af5704a-e5db-4dec-8637-8b4da3839522\scena

DATE: 09/24/2021

TIME: 04:51:08

USER:

COMMENTS: _____

** SIMULATION : Chicago Design Storm - 100yr **

| CHICAGO STORM |
Ptotal= 71.66 mm

IDF curve parameters: A=1735.688
B= 6.014
C= 0.820

used in: INTENSITY = A / (t + B)^C

Duration of storm = 3.00 hrs
 Storm time step = 10.00 min
 Time to peak ratio = 0.33

TIME	RAIN	TIME	RAIN	TIME	RAIN	TIME	RAIN
hrs	mm/hr	hrs	mm/hr	hrs	mm/hr	hrs	mm/hr
0.17	6.05	1.00	178.56	1.83	11.06	2.67	5.76
0.33	7.54	1.17	54.05	2.00	9.29	2.83	5.28
0.50	10.16	1.33	27.32	2.17	8.02	3.00	4.88
0.67	15.97	1.50	18.24	2.33	7.08		
0.83	40.65	1.67	13.74	2.50	6.35		

```

-----
| CALIB          |
| STANDHYD ( 0001) |
| ID= 1 DT= 5.0 min |
-----
  
```

Area (ha)= 0.64
 Total Imp(%)= 82.40 Dir. Conn.(%)= 82.40

	IMPERVIOUS	PERVIOUS (i)
Surface Area (ha)=	0.53	0.11
Dep. Storage (mm)=	1.00	1.50
Average Slope (%)=	1.00	2.00
Length (m)=	65.42	40.00
Mannings n =	0.013	0.250

NOTE: RAINFALL WAS TRANSFORMED TO 5.0 MIN. TIME STEP.

----- TRANSFORMED HYETOGRAPH -----

TIME	RAIN	TIME	RAIN	TIME	RAIN	TIME	RAIN
hrs	mm/hr	hrs	mm/hr	hrs	mm/hr	hrs	mm/hr
0.083	6.05	0.833	40.65	1.583	13.74	2.33	7.08
0.167	6.05	0.917	178.56	1.667	13.74	2.42	6.35
0.250	7.54	1.000	178.56	1.750	11.06	2.50	6.35
0.333	7.54	1.083	54.05	1.833	11.06	2.58	5.76
0.417	10.16	1.167	54.05	1.917	9.29	2.67	5.76
0.500	10.16	1.250	27.32	2.000	9.29	2.75	5.28
0.583	15.97	1.333	27.32	2.083	8.02	2.83	5.28
0.667	15.97	1.417	18.24	2.167	8.02	2.92	4.88
0.750	40.65	1.500	18.24	2.250	7.08	3.00	4.88

Max.Eff.Inten.(mm/hr)=	178.56	105.42
over (min)	5.00	5.00
Storage Coeff. (min)=	1.57 (ii)	4.59 (ii)
Unit Hyd. Tpeak (min)=	5.00	5.00
Unit Hyd. peak (cms)=	0.33	0.23

TOTALS

PEAK FLOW	(cms)=	0.26	0.03	0.294 (iii)
TIME TO PEAK	(hrs)=	1.00	1.00	1.00
RUNOFF VOLUME	(mm)=	70.66	42.81	65.76
TOTAL RAINFALL	(mm)=	71.66	71.66	71.66
RUNOFF COEFFICIENT	=	0.99	0.60	0.92

***** WARNING: STORAGE COEFF. IS SMALLER THAN TIME STEP!

- (i) CN PROCEDURE SELECTED FOR PERVIOUS LOSSES:
CN* = 85.0 Ia = Dep. Storage (Above)
- (ii) TIME STEP (DT) SHOULD BE SMALLER OR EQUAL
THAN THE STORAGE COEFFICIENT.
- (iii) PEAK FLOW DOES NOT INCLUDE BASEFLOW IF ANY.

CALIB	
STANDHYD (0002)	Area (ha)= 0.05
ID= 1 DT= 5.0 min	Total Imp(%)= 99.00 Dir. Conn.(%)= 99.00

		IMPERVIOUS	PERVIOUS (i)
Surface Area	(ha)=	0.05	0.00
Dep. Storage	(mm)=	1.00	1.50
Average Slope	(%)=	1.00	2.00
Length	(m)=	18.44	40.00
Mannings n	=	0.013	0.250

NOTE: RAINFALL WAS TRANSFORMED TO 5.0 MIN. TIME STEP.

----- TRANSFORMED HYETOGRAPH -----

TIME	RAIN	TIME	RAIN	TIME	RAIN	TIME	RAIN
hrs	mm/hr	hrs	mm/hr	hrs	mm/hr	hrs	mm/hr
0.083	6.05	0.833	40.65	1.583	13.74	2.33	7.08
0.167	6.05	0.917	178.56	1.667	13.74	2.42	6.35
0.250	7.54	1.000	178.56	1.750	11.06	2.50	6.35
0.333	7.54	1.083	54.05	1.833	11.06	2.58	5.76
0.417	10.16	1.167	54.05	1.917	9.29	2.67	5.76
0.500	10.16	1.250	27.32	2.000	9.29	2.75	5.28
0.583	15.97	1.333	27.32	2.083	8.02	2.83	5.28
0.667	15.97	1.417	18.24	2.167	8.02	2.92	4.88
0.750	40.65	1.500	18.24	2.250	7.08	3.00	4.88

Max. Eff. Inten. (mm/hr)=	178.56	105.42
over (min)	5.00	5.00
Storage Coeff. (min)=	0.73 (ii)	1.63 (ii)
Unit Hyd. Tpeak (min)=	5.00	5.00
Unit Hyd. peak (cms)=	0.34	0.32

			TOTALS
PEAK FLOW	(cms)=	0.03	0.00
			0.025 (iii)

TIME TO PEAK	(hrs)=	1.00	1.00	1.00
RUNOFF VOLUME	(mm)=	70.66	42.81	70.39
TOTAL RAINFALL	(mm)=	71.66	71.66	71.66
RUNOFF COEFFICIENT	=	0.99	0.60	0.98

***** WARNING: STORAGE COEFF. IS SMALLER THAN TIME STEP!

- (i) CN PROCEDURE SELECTED FOR PERVIOUS LOSSES:
CN* = 85.0 Ia = Dep. Storage (Above)
- (ii) TIME STEP (DT) SHOULD BE SMALLER OR EQUAL THAN THE STORAGE COEFFICIENT.
- (iii) PEAK FLOW DOES NOT INCLUDE BASEFLOW IF ANY.

```

-----
| CALIB |
| STANDHYD ( 0003) | Area (ha)= 0.06
| ID= 1 DT= 5.0 min | Total Imp(%)= 23.50 Dir. Conn.(%)= 23.50
-----

```

		IMPERVIOUS	PERVIOUS (i)
Surface Area	(ha)=	0.01	0.05
Dep. Storage	(mm)=	1.00	1.50
Average Slope	(%)=	1.00	2.00
Length	(m)=	19.83	40.00
Mannings n	=	0.013	0.250

NOTE: RAINFALL WAS TRANSFORMED TO 5.0 MIN. TIME STEP.

```

----- TRANSFORMED HYETOGRAPH -----

```

TIME	RAIN	TIME	RAIN	TIME	RAIN	TIME	RAIN
hrs	mm/hr	hrs	mm/hr	hrs	mm/hr	hrs	mm/hr
0.083	6.05	0.833	40.65	1.583	13.74	2.33	7.08
0.167	6.05	0.917	178.56	1.667	13.74	2.42	6.35
0.250	7.54	1.000	178.56	1.750	11.06	2.50	6.35
0.333	7.54	1.083	54.05	1.833	11.06	2.58	5.76
0.417	10.16	1.167	54.05	1.917	9.29	2.67	5.76
0.500	10.16	1.250	27.32	2.000	9.29	2.75	5.28
0.583	15.97	1.333	27.32	2.083	8.02	2.83	5.28
0.667	15.97	1.417	18.24	2.167	8.02	2.92	4.88
0.750	40.65	1.500	18.24	2.250	7.08	3.00	4.88

Max. Eff. Inten. (mm/hr)=	178.56	105.42
over (min)	5.00	10.00
Storage Coeff. (min)=	0.77 (ii)	7.68 (ii)
Unit Hyd. Tpeak (min)=	5.00	10.00
Unit Hyd. peak (cms)=	0.34	0.13

PEAK FLOW	(cms)=	0.01	0.01	*TOTALS*
TIME TO PEAK	(hrs)=	1.00	1.08	0.015 (iii)
				1.00

RUNOFF VOLUME	(mm)=	70.66	42.81	49.29
TOTAL RAINFALL	(mm)=	71.66	71.66	71.66
RUNOFF COEFFICIENT	=	0.99	0.60	0.69

***** WARNING: STORAGE COEFF. IS SMALLER THAN TIME STEP!

- (i) CN PROCEDURE SELECTED FOR PERVIOUS LOSSES:
CN* = 85.0 Ia = Dep. Storage (Above)
- (ii) TIME STEP (DT) SHOULD BE SMALLER OR EQUAL
THAN THE STORAGE COEFFICIENT.
- (iii) PEAK FLOW DOES NOT INCLUDE BASEFLOW IF ANY.

```

-----
| ADD HYD ( 0004) |
| 1 + 2 = 3 |
-----
          AREA    QPEAK    TPEAK    R.V.
          (ha)    (cms)    (hrs)    (mm)
ID1= 1 ( 0001):  0.64  0.294    1.00    65.76
+ ID2= 2 ( 0002):  0.05  0.025    1.00    70.39
=====
ID = 3 ( 0004):  0.69  0.319    1.00    66.10

```

NOTE: PEAK FLOWS DO NOT INCLUDE BASEFLOWS IF ANY.

```

-----
| ADD HYD ( 0004) |
| 3 + 2 = 1 |
-----
          AREA    QPEAK    TPEAK    R.V.
          (ha)    (cms)    (hrs)    (mm)
ID1= 3 ( 0004):  0.69  0.319    1.00    66.10
+ ID2= 2 ( 0003):  0.06  0.015    1.00    49.29
=====
ID = 1 ( 0004):  0.75  0.334    1.00    64.78

```

NOTE: PEAK FLOWS DO NOT INCLUDE BASEFLOWS IF ANY.

25mm 4hr STORM POST DEVELOPMENT CONTROLLED

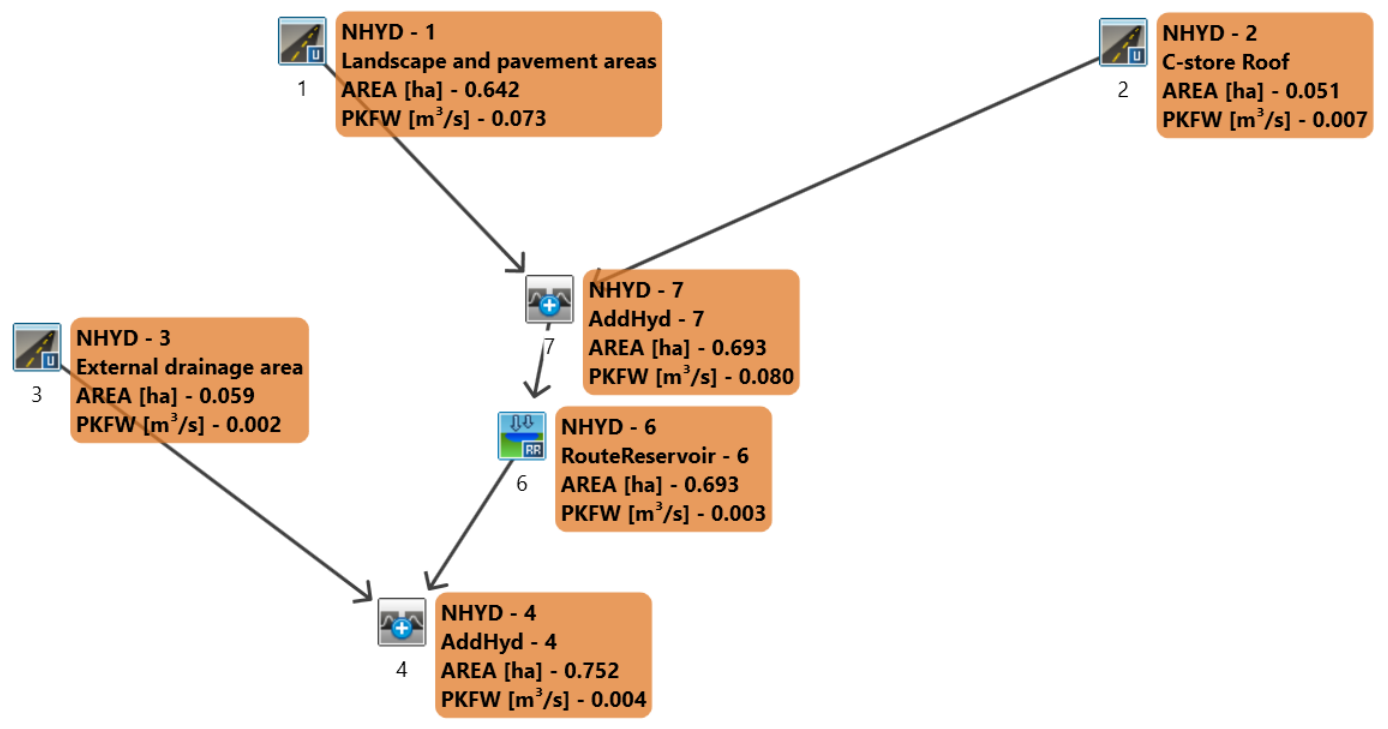

=====

V V I SSSSS U U A L (v 6.2.2005)
V V I SS U U A A L
V V I SS U U AAAAA L
V V I SS U U A A L
WV I SSSSS UUUUU A A LLLLL

000 TTTTT TTTTT H H Y Y M M 000 TM
O O T T H H Y Y MM MM O O
O O T T H H Y M M O O
000 T T H H Y M M 000

Developed and Distributed by Smart City Water Inc
Copyright 2007 - 2021 Smart City Water Inc
All rights reserved.

***** D E T A I L E D O U T P U T *****

Input filename: C:\Program Files (x86)\Visual OTTHYMO 6.2\V02\voin.dat

Output filename:

C:\Users\LiMing\AppData\Local\Civica\VH5\90c30b05-cee4-4f42-8939-ca4273b1ea06\f87fcc
1e-eabf-45bf-a3bb-946d1162d74e\scena

Summary filename:

C:\Users\LiMing\AppData\Local\Civica\VH5\90c30b05-cee4-4f42-8939-ca4273b1ea06\f87fcc
1e-eabf-45bf-a3bb-946d1162d74e\scena

DATE: 09/24/2021

TIME: 04:52:30

USER:

COMMENTS: _____

** SIMULATION : 25mm 4hr Chicago **

| READ STORM | Filename: C:\Users\LiMing\AppData\Local\Temp\
| |

| Ptotal= 25.00 mm |

3991ed44-65ef-453e-a715-2692878d9203\b2416f6e
 Comments: 25mm 4hr Chicago

TIME	RAIN	TIME	RAIN	TIME	RAIN	TIME	RAIN
hrs	mm/hr	hrs	mm/hr	hrs	mm/hr	hrs	mm/hr
0.17	2.07	1.17	5.70	2.17	5.19	3.17	2.80
0.33	2.27	1.33	10.78	2.33	4.47	3.33	2.62
0.50	2.52	1.50	50.21	2.50	3.95	3.50	2.48
0.67	2.88	1.67	13.37	2.67	3.56	3.67	2.35
0.83	3.38	1.83	8.29	2.83	3.25	3.83	2.23
1.00	4.18	2.00	6.30	3.00	3.01	4.00	2.14

| CALIB
 | STANDHYD (0001)
 | ID= 1 DT= 5.0 min |

Area (ha)= 0.64
 Total Imp(%)= 82.40 Dir. Conn.(%)= 82.40

	IMPERVIOUS	PERVIOUS (i)
Surface Area (ha)=	0.53	0.11
Dep. Storage (mm)=	1.00	1.50
Average Slope (%)=	1.00	2.00
Length (m)=	65.42	40.00
Mannings n =	0.013	0.250

NOTE: RAINFALL WAS TRANSFORMED TO 5.0 MIN. TIME STEP.

----- TRANSFORMED HYETOGRAPH -----

TIME	RAIN	TIME	RAIN	TIME	RAIN	TIME	RAIN
hrs	mm/hr	hrs	mm/hr	hrs	mm/hr	hrs	mm/hr
0.083	2.07	1.083	5.70	2.083	5.19	3.08	2.80
0.167	2.07	1.167	5.70	2.167	5.19	3.17	2.80
0.250	2.27	1.250	10.78	2.250	4.47	3.25	2.62
0.333	2.27	1.333	10.78	2.333	4.47	3.33	2.62
0.417	2.52	1.417	50.21	2.417	3.95	3.42	2.48
0.500	2.52	1.500	50.21	2.500	3.95	3.50	2.48
0.583	2.88	1.583	13.37	2.583	3.56	3.58	2.35
0.667	2.88	1.667	13.37	2.667	3.56	3.67	2.35
0.750	3.38	1.750	8.29	2.750	3.25	3.75	2.23
0.833	3.38	1.833	8.29	2.833	3.25	3.83	2.23
0.917	4.17	1.917	6.30	2.917	3.01	3.92	2.14
1.000	4.18	2.000	6.29	3.000	3.01	4.00	2.14

Max.Eff.Inten.(mm/hr)=	50.21	9.88
over (min)	5.00	25.00
Storage Coeff. (min)=	2.61 (ii)	20.42 (ii)
Unit Hyd. Tpeak (min)=	5.00	25.00
Unit Hyd. peak (cms)=	0.29	0.05

				TOTALS
PEAK FLOW	(cms)=	0.07	0.00	0.073 (iii)
TIME TO PEAK	(hrs)=	1.50	1.83	1.50
RUNOFF VOLUME	(mm)=	24.00	8.08	21.18
TOTAL RAINFALL	(mm)=	25.00	25.00	25.00
RUNOFF COEFFICIENT	=	0.96	0.32	0.85

***** WARNING: STORAGE COEFF. IS SMALLER THAN TIME STEP!

- (i) CN PROCEDURE SELECTED FOR PERVIOUS LOSSES:
CN* = 85.0 Ia = Dep. Storage (Above)
- (ii) TIME STEP (DT) SHOULD BE SMALLER OR EQUAL
THAN THE STORAGE COEFFICIENT.
- (iii) PEAK FLOW DOES NOT INCLUDE BASEFLOW IF ANY.

```

-----
| CALIB |
| STANDHYD ( 0002) |
| ID= 1 DT=5.0 min |
-----
Area (ha)= 0.05
Total Imp(%)= 99.00 Dir. Conn.(%)= 99.00

```

		IMPERVIOUS	PERVIOUS (i)
Surface Area	(ha)=	0.05	0.00
Dep. Storage	(mm)=	1.00	1.50
Average Slope	(%)=	1.00	2.00
Length	(m)=	18.44	40.00
Mannings n	=	0.013	0.250

NOTE: RAINFALL WAS TRANSFORMED TO 5.0 MIN. TIME STEP.

```

----- TRANSFORMED HYETOGRAPH -----
TIME RAIN | TIME RAIN | TIME RAIN | TIME RAIN
hrs mm/hr | hrs mm/hr | hrs mm/hr | hrs mm/hr
0.083 2.07 | 1.083 5.70 | 2.083 5.19 | 3.08 2.80
0.167 2.07 | 1.167 5.70 | 2.167 5.19 | 3.17 2.80
0.250 2.27 | 1.250 10.78 | 2.250 4.47 | 3.25 2.62
0.333 2.27 | 1.333 10.78 | 2.333 4.47 | 3.33 2.62
0.417 2.52 | 1.417 50.21 | 2.417 3.95 | 3.42 2.48
0.500 2.52 | 1.500 50.21 | 2.500 3.95 | 3.50 2.48
0.583 2.88 | 1.583 13.37 | 2.583 3.56 | 3.58 2.35
0.667 2.88 | 1.667 13.37 | 2.667 3.56 | 3.67 2.35
0.750 3.38 | 1.750 8.29 | 2.750 3.25 | 3.75 2.23
0.833 3.38 | 1.833 8.29 | 2.833 3.25 | 3.83 2.23
0.917 4.17 | 1.917 6.30 | 2.917 3.01 | 3.92 2.14
1.000 4.18 | 2.000 6.29 | 3.000 3.01 | 4.00 2.14

```

Max.Eff.Inten.(mm/hr)=	50.21	14.26
over (min)	5.00	5.00
Storage Coeff. (min)=	1.22 (ii)	2.70 (ii)

Unit Hyd. Tpeak (min)=	5.00	5.00	
Unit Hyd. peak (cms)=	0.33	0.29	
			TOTALS
PEAK FLOW (cms)=	0.01	0.00	0.007 (iii)
TIME TO PEAK (hrs)=	1.50	1.50	1.50
RUNOFF VOLUME (mm)=	24.00	8.08	23.83
TOTAL RAINFALL (mm)=	25.00	25.00	25.00
RUNOFF COEFFICIENT =	0.96	0.32	0.95

***** WARNING: STORAGE COEFF. IS SMALLER THAN TIME STEP!

- (i) CN PROCEDURE SELECTED FOR PERVIOUS LOSSES:
CN* = 85.0 Ia = Dep. Storage (Above)
- (ii) TIME STEP (DT) SHOULD BE SMALLER OR EQUAL
THAN THE STORAGE COEFFICIENT.
- (iii) PEAK FLOW DOES NOT INCLUDE BASEFLOW IF ANY.

```

-----
| ADD HYD ( 0007) |
| 1 + 2 = 3 |
-----
          AREA    QPEAK    TPEAK    R.V.
          (ha)    (cms)    (hrs)    (mm)
ID1= 1 ( 0001):  0.64  0.073  1.50  21.18
+ ID2= 2 ( 0002):  0.05  0.007  1.50  23.83
=====
ID = 3 ( 0007):  0.69  0.080  1.50  21.37

```

NOTE: PEAK FLOWS DO NOT INCLUDE BASEFLOWS IF ANY.

```

-----
| RESERVOIR( 0006) | OVERFLOW IS OFF
| IN= 2---> OUT= 1 |
| DT= 5.0 min |
-----
          OUTFLOW    STORAGE    OUTFLOW    STORAGE
          (cms)    (ha.m.)    (cms)    (ha.m.)
          0.0000    0.0000    0.0040    0.0220
          0.0010    0.0030    0.0050    0.0380
          0.0020    0.0060    0.0060    0.0500
          0.0030    0.0130    0.0070    0.0510

          AREA    QPEAK    TPEAK    R.V.
          (ha)    (cms)    (hrs)    (mm)
INFLOW : ID= 2 ( 0007)  0.693  0.080  1.50  21.37
OUTFLOW: ID= 1 ( 0006)  0.693  0.003  4.00  20.29

```

```

          PEAK FLOW REDUCTION [Qout/Qin](%)= 3.58
          TIME SHIFT OF PEAK FLOW (min)=150.00
          MAXIMUM STORAGE USED (ha.m.)= 0.0121

```

```

-----
| CALIB |
| STANDHYD ( 0003) |
| ID= 1 DT= 5.0 min |
-----

```

```

Area (ha)= 0.06
Total Imp(%)= 23.50 Dir. Conn.(%)= 23.50

```

```

                IMPERVIOUS      PERVIOUS (i)
Surface Area   (ha)=      0.01      0.05
Dep. Storage   (mm)=      1.00      1.50
Average Slope  (%)=      1.00      2.00
Length         (m)=     19.83     40.00
Mannings n     =        0.013     0.250

```

NOTE: RAINFALL WAS TRANSFORMED TO 5.0 MIN. TIME STEP.

----- TRANSFORMED HYETOGRAPH -----

TIME	RAIN	TIME	RAIN	TIME	RAIN	TIME	RAIN
hrs	mm/hr	hrs	mm/hr	hrs	mm/hr	hrs	mm/hr
0.083	2.07	1.083	5.70	2.083	5.19	3.08	2.80
0.167	2.07	1.167	5.70	2.167	5.19	3.17	2.80
0.250	2.27	1.250	10.78	2.250	4.47	3.25	2.62
0.333	2.27	1.333	10.78	2.333	4.47	3.33	2.62
0.417	2.52	1.417	50.21	2.417	3.95	3.42	2.48
0.500	2.52	1.500	50.21	2.500	3.95	3.50	2.48
0.583	2.88	1.583	13.37	2.583	3.56	3.58	2.35
0.667	2.88	1.667	13.37	2.667	3.56	3.67	2.35
0.750	3.38	1.750	8.29	2.750	3.25	3.75	2.23
0.833	3.38	1.833	8.29	2.833	3.25	3.83	2.23
0.917	4.17	1.917	6.30	2.917	3.01	3.92	2.14
1.000	4.18	2.000	6.29	3.000	3.01	4.00	2.14

```

Max.Eff.Inten.(mm/hr)= 50.21      9.88
over (min)           5.00      20.00
Storage Coeff. (min)= 1.27 (ii)  19.09 (ii)
Unit Hyd. Tpeak (min)= 5.00      20.00
Unit Hyd. peak (cms)= 0.33      0.06

```

TOTALS

```

PEAK FLOW (cms)= 0.00      0.00      0.002 (iii)
TIME TO PEAK (hrs)= 1.50      1.75      1.50
RUNOFF VOLUME (mm)= 24.00      8.08      11.62
TOTAL RAINFALL (mm)= 25.00      25.00      25.00
RUNOFF COEFFICIENT = 0.96      0.32      0.46

```

***** WARNING: STORAGE COEFF. IS SMALLER THAN TIME STEP!

- (i) CN PROCEDURE SELECTED FOR PERVIOUS LOSSES:
CN* = 85.0 Ia = Dep. Storage (Above)
- (ii) TIME STEP (DT) SHOULD BE SMALLER OR EQUAL
THAN THE STORAGE COEFFICIENT.
- (iii) PEAK FLOW DOES NOT INCLUDE BASEFLOW IF ANY.

| ADD HYD (0004) |
1 + 2 = 3

	AREA (ha)	QPEAK (cms)	TPEAK (hrs)	R.V. (mm)
ID1= 1 (0003):	0.06	0.002	1.50	11.62
+ ID2= 2 (0006):	0.69	0.003	4.00	20.29
=====				
ID = 3 (0004):	0.75	0.004	1.50	19.61

NOTE: PEAK FLOWS DO NOT INCLUDE BASEFLOWS IF ANY.

2-YR STORM POST DEVELOPMENT CONTROLLED

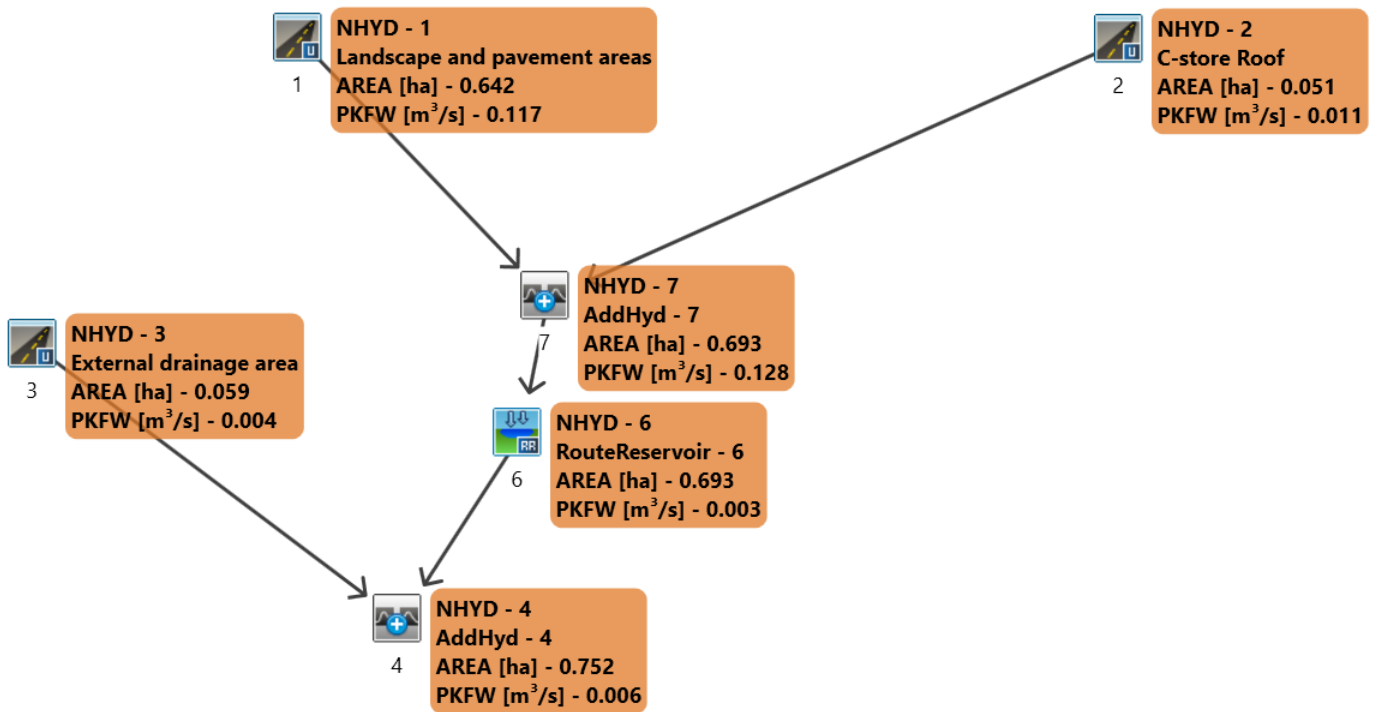

=====

V V I SSSSS U U A L (v 6.2.2005)
V V I SS U U A A L
V V I SS U U AAAAA L
V V I SS U U A A L
WV I SSSSS UUUUU A A LLLLL

000 TTTTT TTTTT H H Y Y M M 000 TM
0 0 T T H H Y Y MM MM 0 0
0 0 T T H H Y M M 0 0
000 T T H H Y M M 000

Developed and Distributed by Smart City Water Inc
Copyright 2007 - 2021 Smart City Water Inc
All rights reserved.

***** D E T A I L E D O U T P U T *****

Input filename: C:\Program Files (x86)\Visual OTTHYMO 6.2\V02\voin.dat

Output filename:

C:\Users\LiMing\AppData\Local\Civica\VH5\90c30b05-cee4-4f42-8939-ca4273b1ea06\4a1f5169-4eeb-472b-ba17-5fca398f9fd2\scena

Summary filename:

C:\Users\LiMing\AppData\Local\Civica\VH5\90c30b05-cee4-4f42-8939-ca4273b1ea06\4a1f5169-4eeb-472b-ba17-5fca398f9fd2\scena

DATE: 09/24/2021

TIME: 04:52:30

USER:

COMMENTS: _____

** SIMULATION : Chicago Design Storm - 2yr **

| CHICAGO STORM |
Ptotal= 31.86 mm

IDF curve parameters: A= 732.951
B= 6.199
C= 0.810

used in: INTENSITY = A / (t + B)^C

Duration of storm = 3.00 hrs
 Storm time step = 10.00 min
 Time to peak ratio = 0.33

TIME	RAIN	TIME	RAIN	TIME	RAIN	TIME	RAIN
hrs	mm/hr	hrs	mm/hr	hrs	mm/hr	hrs	mm/hr
0.17	2.81	1.00	76.81	1.83	5.09	2.67	2.68
0.33	3.50	1.17	24.08	2.00	4.29	2.83	2.46
0.50	4.69	1.33	12.36	2.17	3.72	3.00	2.28
0.67	7.30	1.50	8.32	2.33	3.29		
0.83	18.21	1.67	6.30	2.50	2.95		

```

-----
| CALIB          |
| STANDHYD ( 0001) |
| ID= 1 DT= 5.0 min |
-----
  
```

Area (ha)= 0.64
 Total Imp(%)= 82.40 Dir. Conn.(%)= 82.40

	IMPERVIOUS	PERVIOUS (i)
Surface Area (ha)=	0.53	0.11
Dep. Storage (mm)=	1.00	1.50
Average Slope (%)=	1.00	2.00
Length (m)=	65.42	40.00
Mannings n =	0.013	0.250

NOTE: RAINFALL WAS TRANSFORMED TO 5.0 MIN. TIME STEP.

----- TRANSFORMED HYETOGRAPH -----

TIME	RAIN	TIME	RAIN	TIME	RAIN	TIME	RAIN
hrs	mm/hr	hrs	mm/hr	hrs	mm/hr	hrs	mm/hr
0.083	2.81	0.833	18.21	1.583	6.30	2.33	3.29
0.167	2.81	0.917	76.80	1.667	6.30	2.42	2.95
0.250	3.50	1.000	76.81	1.750	5.09	2.50	2.95
0.333	3.50	1.083	24.08	1.833	5.09	2.58	2.68
0.417	4.69	1.167	24.08	1.917	4.29	2.67	2.68
0.500	4.69	1.250	12.36	2.000	4.29	2.75	2.46
0.583	7.30	1.333	12.36	2.083	3.72	2.83	2.46
0.667	7.30	1.417	8.32	2.167	3.72	2.92	2.28
0.750	18.21	1.500	8.32	2.250	3.29	3.00	2.28

Max.Eff.Inten.(mm/hr)=	76.81	26.60
over (min)	5.00	10.00
Storage Coeff. (min)=	2.20 (ii)	6.43 (ii)
Unit Hyd. Tpeak (min)=	5.00	10.00
Unit Hyd. peak (cms)=	0.30	0.14

TOTALS

PEAK FLOW	(cms)=	0.11	0.01	0.117 (iii)
TIME TO PEAK	(hrs)=	1.00	1.08	1.00
RUNOFF VOLUME	(mm)=	30.86	12.26	27.58
TOTAL RAINFALL	(mm)=	31.86	31.86	31.86
RUNOFF COEFFICIENT	=	0.97	0.38	0.87

***** WARNING: STORAGE COEFF. IS SMALLER THAN TIME STEP!

- (i) CN PROCEDURE SELECTED FOR PERVIOUS LOSSES:
CN* = 85.0 Ia = Dep. Storage (Above)
- (ii) TIME STEP (DT) SHOULD BE SMALLER OR EQUAL
THAN THE STORAGE COEFFICIENT.
- (iii) PEAK FLOW DOES NOT INCLUDE BASEFLOW IF ANY.

```

-----
| CALIB |
| STANDHYD ( 0002) | Area (ha)= 0.05
| ID= 1 DT= 5.0 min | Total Imp(%)= 99.00 Dir. Conn.(%)= 99.00
-----

```

		IMPERVIOUS	PERVIOUS (i)
Surface Area	(ha)=	0.05	0.00
Dep. Storage	(mm)=	1.00	1.50
Average Slope	(%)=	1.00	2.00
Length	(m)=	18.44	40.00
Mannings n	=	0.013	0.250

NOTE: RAINFALL WAS TRANSFORMED TO 5.0 MIN. TIME STEP.

```

----- TRANSFORMED HYETOGRAPH -----

```

TIME	RAIN	TIME	RAIN	TIME	RAIN	TIME	RAIN
hrs	mm/hr	hrs	mm/hr	hrs	mm/hr	hrs	mm/hr
0.083	2.81	0.833	18.21	1.583	6.30	2.33	3.29
0.167	2.81	0.917	76.80	1.667	6.30	2.42	2.95
0.250	3.50	1.000	76.81	1.750	5.09	2.50	2.95
0.333	3.50	1.083	24.08	1.833	5.09	2.58	2.68
0.417	4.69	1.167	24.08	1.917	4.29	2.67	2.68
0.500	4.69	1.250	12.36	2.000	4.29	2.75	2.46
0.583	7.30	1.333	12.36	2.083	3.72	2.83	2.46
0.667	7.30	1.417	8.32	2.167	3.72	2.92	2.28
0.750	18.21	1.500	8.32	2.250	3.29	3.00	2.28

Max.Eff.Inten.(mm/hr)=	76.81	26.60
over (min)	5.00	5.00
Storage Coeff. (min)=	1.03 (ii)	2.28 (ii)
Unit Hyd. Tpeak (min)=	5.00	5.00
Unit Hyd. peak (cms)=	0.34	0.30

PEAK FLOW	(cms)=	0.01	0.00	*TOTALS*	0.011 (iii)
-----------	--------	------	------	----------	-------------

TIME TO PEAK	(hrs)=	1.00	1.00	1.00
RUNOFF VOLUME	(mm)=	30.86	12.26	30.67
TOTAL RAINFALL	(mm)=	31.86	31.86	31.86
RUNOFF COEFFICIENT	=	0.97	0.38	0.96

***** WARNING: STORAGE COEFF. IS SMALLER THAN TIME STEP!

- (i) CN PROCEDURE SELECTED FOR PERVIOUS LOSSES:
CN* = 85.0 Ia = Dep. Storage (Above)
- (ii) TIME STEP (DT) SHOULD BE SMALLER OR EQUAL THAN THE STORAGE COEFFICIENT.
- (iii) PEAK FLOW DOES NOT INCLUDE BASEFLOW IF ANY.

```

-----
| ADD HYD ( 0007) |
| 1 + 2 = 3 |
-----
| AREA   QPEAK   TPEAK   R.V.
| (ha)   (cms)   (hrs)   (mm)
|-----|
| ID1= 1 ( 0001): 0.64  0.117  1.00  27.58
| + ID2= 2 ( 0002): 0.05  0.011  1.00  30.67
|=====|
| ID = 3 ( 0007): 0.69  0.128  1.00  27.81

```

NOTE: PEAK FLOWS DO NOT INCLUDE BASEFLOWS IF ANY.

```

-----
| RESERVOIR( 0006) | OVERFLOW IS OFF
| IN= 2---> OUT= 1 |
| DT= 5.0 min |
-----
| OUTFLOW   STORAGE | OUTFLOW   STORAGE
| (cms)     (ha.m.) | (cms)     (ha.m.)
|-----|
| 0.0000    0.0000 | 0.0040    0.0220
| 0.0010    0.0030 | 0.0050    0.0380
| 0.0020    0.0060 | 0.0060    0.0500
| 0.0030    0.0130 | 0.0070    0.0510

```

	AREA (ha)	QPEAK (cms)	TPEAK (hrs)	R.V. (mm)
INFLOW : ID= 2 (0007)	0.693	0.128	1.00	27.81
OUTFLOW: ID= 1 (0006)	0.693	0.003	3.00	26.72

PEAK FLOW REDUCTION [Qout/Qin](%)= 2.67
 TIME SHIFT OF PEAK FLOW (min)=120.00
 MAXIMUM STORAGE USED (ha.m.)= 0.0167

```

-----
| CALIB
| STANDHYD ( 0003) | Area (ha)= 0.06
| ID= 1 DT= 5.0 min | Total Imp(%)= 23.50 Dir. Conn.(%)= 23.50

```

		IMPERVIOUS	PERVIOUS (i)
Surface Area	(ha)=	0.01	0.05
Dep. Storage	(mm)=	1.00	1.50
Average Slope	(%)=	1.00	2.00
Length	(m)=	19.83	40.00
Mannings n	=	0.013	0.250

NOTE: RAINFALL WAS TRANSFORMED TO 5.0 MIN. TIME STEP.

----- TRANSFORMED HYETOGRAPH -----							
TIME	RAIN	TIME	RAIN	TIME	RAIN	TIME	RAIN
hrs	mm/hr	hrs	mm/hr	hrs	mm/hr	hrs	mm/hr
0.083	2.81	0.833	18.21	1.583	6.30	2.33	3.29
0.167	2.81	0.917	76.80	1.667	6.30	2.42	2.95
0.250	3.50	1.000	76.81	1.750	5.09	2.50	2.95
0.333	3.50	1.083	24.08	1.833	5.09	2.58	2.68
0.417	4.69	1.167	24.08	1.917	4.29	2.67	2.68
0.500	4.69	1.250	12.36	2.000	4.29	2.75	2.46
0.583	7.30	1.333	12.36	2.083	3.72	2.83	2.46
0.667	7.30	1.417	8.32	2.167	3.72	2.92	2.28
0.750	18.21	1.500	8.32	2.250	3.29	3.00	2.28

Max.Eff.Inten.(mm/hr)=	76.81	21.72
over (min)	5.00	15.00
Storage Coeff. (min)=	1.08 (ii)	14.07 (ii)
Unit Hyd. Tpeak (min)=	5.00	15.00
Unit Hyd. peak (cms)=	0.34	0.08

TOTALS

PEAK FLOW (cms)=	0.00	0.00	0.004 (iii)
TIME TO PEAK (hrs)=	1.00	1.17	1.00
RUNOFF VOLUME (mm)=	30.86	12.26	16.50
TOTAL RAINFALL (mm)=	31.86	31.86	31.86
RUNOFF COEFFICIENT =	0.97	0.38	0.52

***** WARNING: STORAGE COEFF. IS SMALLER THAN TIME STEP!

- (i) CN PROCEDURE SELECTED FOR PERVIOUS LOSSES:
CN* = 85.0 Ia = Dep. Storage (Above)
- (ii) TIME STEP (DT) SHOULD BE SMALLER OR EQUAL
THAN THE STORAGE COEFFICIENT.
- (iii) PEAK FLOW DOES NOT INCLUDE BASEFLOW IF ANY.

| ADD HYD (0004) |
1 + 2 = 3

AREA	QPEAK	TPEAK	R.V.
(ha)	(cms)	(hrs)	(mm)

ID1= 1 (0003):	0.06	0.004	1.00	16.50
+ ID2= 2 (0006):	0.69	0.003	3.00	26.72
=====				
ID = 3 (0004):	0.75	0.006	1.00	25.92

NOTE: PEAK FLOWS DO NOT INCLUDE BASEFLOWS IF ANY.

5-YR STORM POST DEVELOPMENT CONTROLLED

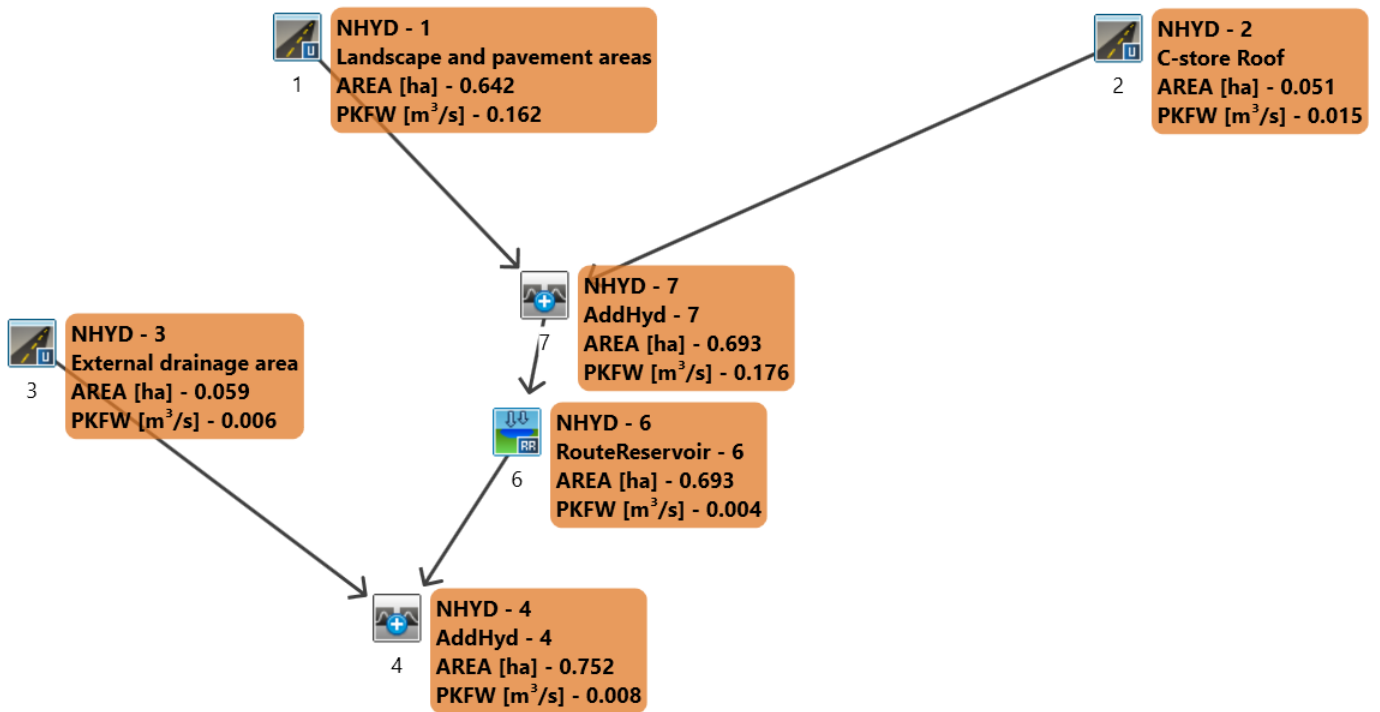

=====

V V I SSSSS U U A L (v 6.2.2005)
V V I SS U U A A L
V V I SS U U AAAAA L
V V I SS U U A A L
WV I SSSSS UUUUU A A LLLLL

000 TTTTT TTTTT H H Y Y M M 000 TM
0 0 T T H H Y Y MM MM 0 0
0 0 T T H H Y M M 0 0
000 T T H H Y M M 000

Developed and Distributed by Smart City Water Inc
Copyright 2007 - 2021 Smart City Water Inc
All rights reserved.

***** D E T A I L E D O U T P U T *****

Input filename: C:\Program Files (x86)\Visual OTTHYMO 6.2\V02\voin.dat

Output filename:

C:\Users\LiMing\AppData\Local\Civica\VH5\90c30b05-cee4-4f42-8939-ca4273b1ea06\bd1924
1f-aa6a-4c5c-a56c-703c31d64412\scena

Summary filename:

C:\Users\LiMing\AppData\Local\Civica\VH5\90c30b05-cee4-4f42-8939-ca4273b1ea06\bd1924
1f-aa6a-4c5c-a56c-703c31d64412\scena

DATE: 09/24/2021

TIME: 04:52:30

USER:

COMMENTS: _____

** SIMULATION : Chicago Design Storm - 5yr **

| CHICAGO STORM |
Ptotal= 42.51 mm

IDF curve parameters: A= 998.071
B= 6.053
C= 0.814

used in: INTENSITY = A / (t + B)^C

Duration of storm = 3.00 hrs
 Storm time step = 10.00 min
 Time to peak ratio = 0.33

TIME	RAIN	TIME	RAIN	TIME	RAIN	TIME	RAIN
hrs	mm/hr	hrs	mm/hr	hrs	mm/hr	hrs	mm/hr
0.17	3.68	1.00	104.19	1.83	6.69	2.67	3.51
0.33	4.58	1.17	32.04	2.00	5.63	2.83	3.22
0.50	6.15	1.33	16.34	2.17	4.87	3.00	2.98
0.67	9.61	1.50	10.96	2.33	4.30		
0.83	24.17	1.67	8.29	2.50	3.86		

```

-----
| CALIB          |
| STANDHYD ( 0001) |
| ID= 1 DT= 5.0 min |
-----
  
```

Area (ha)= 0.64
 Total Imp(%)= 82.40 Dir. Conn.(%)= 82.40

	IMPERVIOUS	PERVIOUS (i)
Surface Area (ha)=	0.53	0.11
Dep. Storage (mm)=	1.00	1.50
Average Slope (%)=	1.00	2.00
Length (m)=	65.42	40.00
Mannings n =	0.013	0.250

NOTE: RAINFALL WAS TRANSFORMED TO 5.0 MIN. TIME STEP.

----- TRANSFORMED HYETOGRAPH -----

TIME	RAIN	TIME	RAIN	TIME	RAIN	TIME	RAIN
hrs	mm/hr	hrs	mm/hr	hrs	mm/hr	hrs	mm/hr
0.083	3.68	0.833	24.17	1.583	8.29	2.33	4.30
0.167	3.68	0.917	104.19	1.667	8.29	2.42	3.86
0.250	4.58	1.000	104.19	1.750	6.69	2.50	3.86
0.333	4.58	1.083	32.04	1.833	6.69	2.58	3.51
0.417	6.15	1.167	32.04	1.917	5.63	2.67	3.51
0.500	6.15	1.250	16.34	2.000	5.63	2.75	3.22
0.583	9.61	1.333	16.34	2.083	4.87	2.83	3.22
0.667	9.61	1.417	10.96	2.167	4.87	2.92	2.98
0.750	24.17	1.500	10.96	2.250	4.30	3.00	2.98

Max.Eff.Inten.(mm/hr)=	104.19	44.88
over (min)	5.00	10.00
Storage Coeff. (min)=	1.95 (ii)	5.69 (ii)
Unit Hyd. Tpeak (min)=	5.00	10.00
Unit Hyd. peak (cms)=	0.31	0.15

TOTALS

PEAK FLOW	(cms)=	0.15	0.01	0.162 (iii)
TIME TO PEAK	(hrs)=	1.00	1.08	1.00
RUNOFF VOLUME	(mm)=	41.51	19.60	37.65
TOTAL RAINFALL	(mm)=	42.51	42.51	42.51
RUNOFF COEFFICIENT	=	0.98	0.46	0.89

***** WARNING: STORAGE COEFF. IS SMALLER THAN TIME STEP!

- (i) CN PROCEDURE SELECTED FOR PERVIOUS LOSSES:
CN* = 85.0 Ia = Dep. Storage (Above)
- (ii) TIME STEP (DT) SHOULD BE SMALLER OR EQUAL
THAN THE STORAGE COEFFICIENT.
- (iii) PEAK FLOW DOES NOT INCLUDE BASEFLOW IF ANY.

```

-----
| CALIB |
| STANDHYD ( 0002) | Area (ha)= 0.05
| ID= 1 DT= 5.0 min | Total Imp(%)= 99.00 Dir. Conn.(%)= 99.00
-----

```

		IMPERVIOUS	PERVIOUS (i)
Surface Area	(ha)=	0.05	0.00
Dep. Storage	(mm)=	1.00	1.50
Average Slope	(%)=	1.00	2.00
Length	(m)=	18.44	40.00
Mannings n	=	0.013	0.250

NOTE: RAINFALL WAS TRANSFORMED TO 5.0 MIN. TIME STEP.

```

----- TRANSFORMED HYETOGRAPH -----

```

TIME	RAIN	TIME	RAIN	TIME	RAIN	TIME	RAIN
hrs	mm/hr	hrs	mm/hr	hrs	mm/hr	hrs	mm/hr
0.083	3.68	0.833	24.17	1.583	8.29	2.33	4.30
0.167	3.68	0.917	104.19	1.667	8.29	2.42	3.86
0.250	4.58	1.000	104.19	1.750	6.69	2.50	3.86
0.333	4.58	1.083	32.04	1.833	6.69	2.58	3.51
0.417	6.15	1.167	32.04	1.917	5.63	2.67	3.51
0.500	6.15	1.250	16.34	2.000	5.63	2.75	3.22
0.583	9.61	1.333	16.34	2.083	4.87	2.83	3.22
0.667	9.61	1.417	10.96	2.167	4.87	2.92	2.98
0.750	24.17	1.500	10.96	2.250	4.30	3.00	2.98

Max.Eff.Inten.(mm/hr)=	104.19	44.88
over (min)	5.00	5.00
Storage Coeff. (min)=	0.91 (ii)	2.02 (ii)
Unit Hyd. Tpeak (min)=	5.00	5.00
Unit Hyd. peak (cms)=	0.34	0.31

PEAK FLOW	(cms)=	0.01	0.00	*TOTALS*
				0.015 (iii)

TIME TO PEAK	(hrs)=	1.00	1.00	1.00
RUNOFF VOLUME	(mm)=	41.51	19.60	41.29
TOTAL RAINFALL	(mm)=	42.51	42.51	42.51
RUNOFF COEFFICIENT	=	0.98	0.46	0.97

***** WARNING: STORAGE COEFF. IS SMALLER THAN TIME STEP!

- (i) CN PROCEDURE SELECTED FOR PERVIOUS LOSSES:
CN* = 85.0 Ia = Dep. Storage (Above)
- (ii) TIME STEP (DT) SHOULD BE SMALLER OR EQUAL
THAN THE STORAGE COEFFICIENT.
- (iii) PEAK FLOW DOES NOT INCLUDE BASEFLOW IF ANY.

```

-----
| ADD HYD ( 0007) |
| 1 + 2 = 3 |
-----
|          AREA   QPEAK   TPEAK   R.V.
|          (ha)   (cms)   (hrs)   (mm)
-----
| ID1= 1 ( 0001):  0.64  0.162  1.00  37.65
| + ID2= 2 ( 0002):  0.05  0.015  1.00  41.29
|=====
| ID = 3 ( 0007):  0.69  0.176  1.00  37.92
-----

```

NOTE: PEAK FLOWS DO NOT INCLUDE BASEFLOWS IF ANY.

```

-----
| RESERVOIR( 0006) | OVERFLOW IS OFF
| IN= 2---> OUT= 1 |
| DT= 5.0 min |
-----
|          OUTFLOW   STORAGE   | OUTFLOW   STORAGE
|          (cms)    (ha.m.)   | (cms)    (ha.m.)
-----
| 0.0000   0.0000   | 0.0040   0.0220
| 0.0010   0.0030   | 0.0050   0.0380
| 0.0020   0.0060   | 0.0060   0.0500
| 0.0030   0.0130   | 0.0070   0.0510
-----

```

	AREA (ha)	QPEAK (cms)	TPEAK (hrs)	R.V. (mm)
INFLOW : ID= 2 (0007)	0.693	0.176	1.00	37.92
OUTFLOW: ID= 1 (0006)	0.693	0.004	3.00	36.82

PEAK FLOW REDUCTION [Qout/Qin](%)= 2.31
 TIME SHIFT OF PEAK FLOW (min)=120.00
 MAXIMUM STORAGE USED (ha.m.)= 0.0232

```

-----
| CALIB
| STANDHYD ( 0003) | Area (ha)= 0.06
| ID= 1 DT= 5.0 min | Total Imp(%)= 23.50 Dir. Conn.(%)= 23.50
-----

```

		IMPERVIOUS	PERVIOUS (i)
Surface Area	(ha)=	0.01	0.05
Dep. Storage	(mm)=	1.00	1.50
Average Slope	(%)=	1.00	2.00
Length	(m)=	19.83	40.00
Mannings n	=	0.013	0.250

NOTE: RAINFALL WAS TRANSFORMED TO 5.0 MIN. TIME STEP.

----- TRANSFORMED HYETOGRAPH -----							
TIME	RAIN	TIME	RAIN	TIME	RAIN	TIME	RAIN
hrs	mm/hr	hrs	mm/hr	hrs	mm/hr	hrs	mm/hr
0.083	3.68	0.833	24.17	1.583	8.29	2.33	4.30
0.167	3.68	0.917	104.19	1.667	8.29	2.42	3.86
0.250	4.58	1.000	104.19	1.750	6.69	2.50	3.86
0.333	4.58	1.083	32.04	1.833	6.69	2.58	3.51
0.417	6.15	1.167	32.04	1.917	5.63	2.67	3.51
0.500	6.15	1.250	16.34	2.000	5.63	2.75	3.22
0.583	9.61	1.333	16.34	2.083	4.87	2.83	3.22
0.667	9.61	1.417	10.96	2.167	4.87	2.92	2.98
0.750	24.17	1.500	10.96	2.250	4.30	3.00	2.98

Max.Eff.Inten.(mm/hr)=	104.19	44.88
over (min)	5.00	15.00
Storage Coeff. (min)=	0.95 (ii)	10.68 (ii)
Unit Hyd. Tpeak (min)=	5.00	15.00
Unit Hyd. peak (cms)=	0.34	0.09

TOTALS

PEAK FLOW (cms)=	0.00	0.00	0.006 (iii)
TIME TO PEAK (hrs)=	1.00	1.17	1.00
RUNOFF VOLUME (mm)=	41.51	19.60	24.64
TOTAL RAINFALL (mm)=	42.51	42.51	42.51
RUNOFF COEFFICIENT =	0.98	0.46	0.58

***** WARNING: STORAGE COEFF. IS SMALLER THAN TIME STEP!

- (i) CN PROCEDURE SELECTED FOR PERVIOUS LOSSES:
CN* = 85.0 Ia = Dep. Storage (Above)
- (ii) TIME STEP (DT) SHOULD BE SMALLER OR EQUAL
THAN THE STORAGE COEFFICIENT.
- (iii) PEAK FLOW DOES NOT INCLUDE BASEFLOW IF ANY.

 | ADD HYD (0004) |
1 + 2 = 3

AREA	QPEAK	TPEAK	R.V.
(ha)	(cms)	(hrs)	(mm)

ID1= 1 (0003):	0.06	0.006	1.00	24.64
+ ID2= 2 (0006):	0.69	0.004	3.00	36.82
=====				
ID = 3 (0004):	0.75	0.008	1.00	35.87

NOTE: PEAK FLOWS DO NOT INCLUDE BASEFLOWS IF ANY.

100-YR STORM POST DEVELOPMENT CONTROLLED

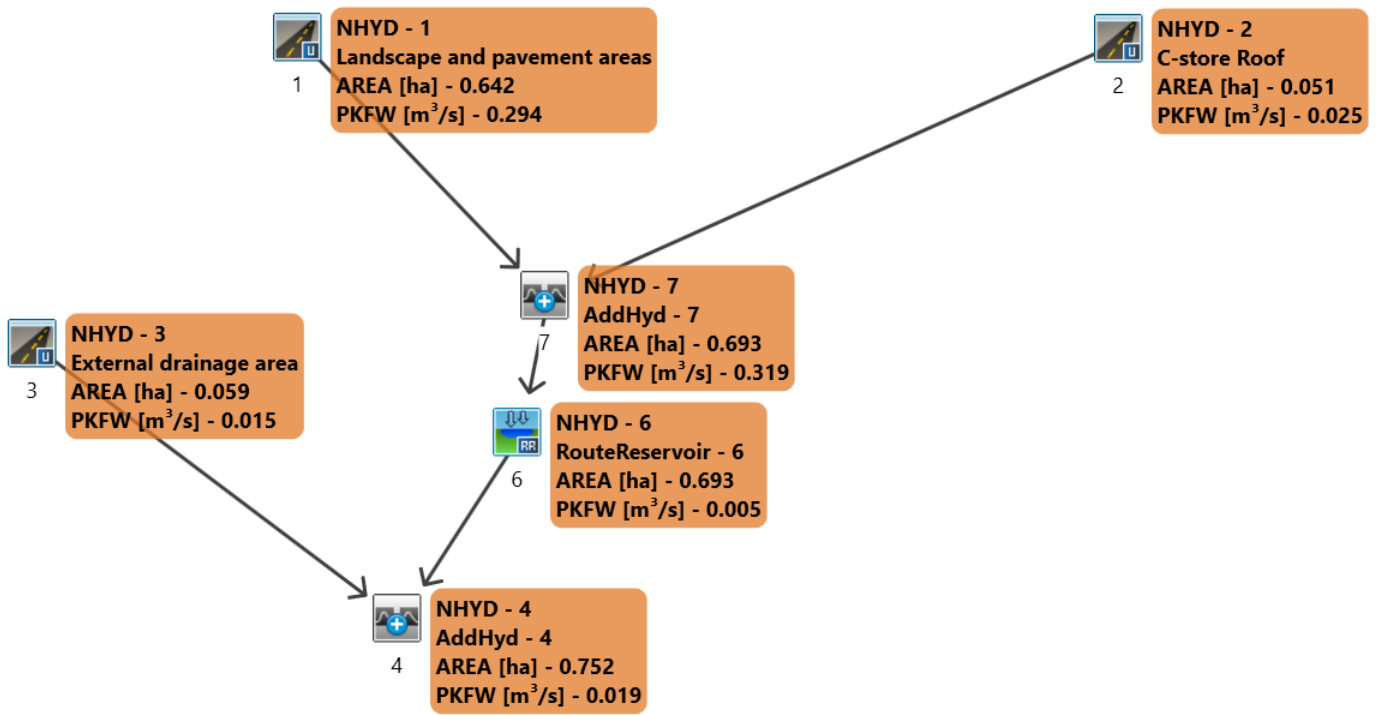

=====

V V I SSSSS U U A L (v 6.2.2005)
V V I SS U U A A L
V V I SS U U AAAAA L
V V I SS U U A A L
VV I SSSSS UUUUU A A LLLLL

000 TTTTT TTTTT H H Y Y M M 000 TM
0 0 T T H H Y Y MM MM 0 0
0 0 T T H H Y M M 0 0
000 T T H H Y M M 000

Developed and Distributed by Smart City Water Inc
Copyright 2007 - 2021 Smart City Water Inc
All rights reserved.

***** D E T A I L E D O U T P U T *****

Input filename: C:\Program Files (x86)\Visual OTTHYMO 6.2\V02\voin.dat

Output filename:

C:\Users\LiMing\AppData\Local\Civica\VH5\90c30b05-cee4-4f42-8939-ca4273b1ea06\12601d06-a899-4be6-82e0-51603667104e\scena

Summary filename:

C:\Users\LiMing\AppData\Local\Civica\VH5\90c30b05-cee4-4f42-8939-ca4273b1ea06\12601d06-a899-4be6-82e0-51603667104e\scena

DATE: 09/24/2021

TIME: 04:52:30

USER:

COMMENTS: _____

** SIMULATION : Chicago Design Storm - 100yr **

| CHICAGO STORM |
Ptotal= 71.66 mm

IDF curve parameters: A=1735.688
B= 6.014
C= 0.820

used in: INTENSITY = A / (t + B)^C

Duration of storm = 3.00 hrs
 Storm time step = 10.00 min
 Time to peak ratio = 0.33

TIME	RAIN	TIME	RAIN	TIME	RAIN	TIME	RAIN
hrs	mm/hr	hrs	mm/hr	hrs	mm/hr	hrs	mm/hr
0.17	6.05	1.00	178.56	1.83	11.06	2.67	5.76
0.33	7.54	1.17	54.05	2.00	9.29	2.83	5.28
0.50	10.16	1.33	27.32	2.17	8.02	3.00	4.88
0.67	15.97	1.50	18.24	2.33	7.08		
0.83	40.65	1.67	13.74	2.50	6.35		

```

-----
| CALIB          |
| STANDHYD ( 0001) |
| ID= 1 DT= 5.0 min |
-----
  
```

Area (ha)= 0.64
 Total Imp(%)= 82.40 Dir. Conn.(%)= 82.40

	IMPERVIOUS	PERVIOUS (i)
Surface Area (ha)=	0.53	0.11
Dep. Storage (mm)=	1.00	1.50
Average Slope (%)=	1.00	2.00
Length (m)=	65.42	40.00
Mannings n =	0.013	0.250

NOTE: RAINFALL WAS TRANSFORMED TO 5.0 MIN. TIME STEP.

----- TRANSFORMED HYETOGRAPH -----

TIME	RAIN	TIME	RAIN	TIME	RAIN	TIME	RAIN
hrs	mm/hr	hrs	mm/hr	hrs	mm/hr	hrs	mm/hr
0.083	6.05	0.833	40.65	1.583	13.74	2.33	7.08
0.167	6.05	0.917	178.56	1.667	13.74	2.42	6.35
0.250	7.54	1.000	178.56	1.750	11.06	2.50	6.35
0.333	7.54	1.083	54.05	1.833	11.06	2.58	5.76
0.417	10.16	1.167	54.05	1.917	9.29	2.67	5.76
0.500	10.16	1.250	27.32	2.000	9.29	2.75	5.28
0.583	15.97	1.333	27.32	2.083	8.02	2.83	5.28
0.667	15.97	1.417	18.24	2.167	8.02	2.92	4.88
0.750	40.65	1.500	18.24	2.250	7.08	3.00	4.88

Max.Eff.Inten.(mm/hr)= 178.56 105.42
 over (min) 5.00 5.00
 Storage Coeff. (min)= 1.57 (ii) 4.59 (ii)
 Unit Hyd. Tpeak (min)= 5.00 5.00
 Unit Hyd. peak (cms)= 0.33 0.23

TOTALS

PEAK FLOW	(cms)=	0.26	0.03	0.294 (iii)
TIME TO PEAK	(hrs)=	1.00	1.00	1.00
RUNOFF VOLUME	(mm)=	70.66	42.81	65.76
TOTAL RAINFALL	(mm)=	71.66	71.66	71.66
RUNOFF COEFFICIENT	=	0.99	0.60	0.92

***** WARNING: STORAGE COEFF. IS SMALLER THAN TIME STEP!

- (i) CN PROCEDURE SELECTED FOR PERVIOUS LOSSES:
CN* = 85.0 Ia = Dep. Storage (Above)
- (ii) TIME STEP (DT) SHOULD BE SMALLER OR EQUAL
THAN THE STORAGE COEFFICIENT.
- (iii) PEAK FLOW DOES NOT INCLUDE BASEFLOW IF ANY.

```

-----
| CALIB |
| STANDHYD ( 0002) | Area (ha)= 0.05
| ID= 1 DT= 5.0 min | Total Imp(%)= 99.00 Dir. Conn.(%)= 99.00
-----

```

		IMPERVIOUS	PERVIOUS (i)
Surface Area	(ha)=	0.05	0.00
Dep. Storage	(mm)=	1.00	1.50
Average Slope	(%)=	1.00	2.00
Length	(m)=	18.44	40.00
Mannings n	=	0.013	0.250

NOTE: RAINFALL WAS TRANSFORMED TO 5.0 MIN. TIME STEP.

```

----- TRANSFORMED HYETOGRAPH -----

```

TIME	RAIN	TIME	RAIN	TIME	RAIN	TIME	RAIN
hrs	mm/hr	hrs	mm/hr	hrs	mm/hr	hrs	mm/hr
0.083	6.05	0.833	40.65	1.583	13.74	2.33	7.08
0.167	6.05	0.917	178.56	1.667	13.74	2.42	6.35
0.250	7.54	1.000	178.56	1.750	11.06	2.50	6.35
0.333	7.54	1.083	54.05	1.833	11.06	2.58	5.76
0.417	10.16	1.167	54.05	1.917	9.29	2.67	5.76
0.500	10.16	1.250	27.32	2.000	9.29	2.75	5.28
0.583	15.97	1.333	27.32	2.083	8.02	2.83	5.28
0.667	15.97	1.417	18.24	2.167	8.02	2.92	4.88
0.750	40.65	1.500	18.24	2.250	7.08	3.00	4.88

Max. Eff. Inten. (mm/hr)=	178.56	105.42
over (min)	5.00	5.00
Storage Coeff. (min)=	0.73 (ii)	1.63 (ii)
Unit Hyd. Tpeak (min)=	5.00	5.00
Unit Hyd. peak (cms)=	0.34	0.32

PEAK FLOW	(cms)=	0.03	0.00	*TOTALS*	0.025 (iii)
-----------	--------	------	------	----------	-------------

TIME TO PEAK	(hrs)=	1.00	1.00	1.00
RUNOFF VOLUME	(mm)=	70.66	42.81	70.39
TOTAL RAINFALL	(mm)=	71.66	71.66	71.66
RUNOFF COEFFICIENT	=	0.99	0.60	0.98

***** WARNING: STORAGE COEFF. IS SMALLER THAN TIME STEP!

- (i) CN PROCEDURE SELECTED FOR PERVIOUS LOSSES:
CN* = 85.0 Ia = Dep. Storage (Above)
- (ii) TIME STEP (DT) SHOULD BE SMALLER OR EQUAL THAN THE STORAGE COEFFICIENT.
- (iii) PEAK FLOW DOES NOT INCLUDE BASEFLOW IF ANY.

```

-----
| ADD HYD ( 0007) |
| 1 + 2 = 3 |
-----
| AREA   QPEAK   TPEAK   R.V.
| (ha)   (cms)   (hrs)   (mm)
-----
| ID1= 1 ( 0001): 0.64  0.294  1.00  65.76
| + ID2= 2 ( 0002): 0.05  0.025  1.00  70.39
|=====
| ID = 3 ( 0007): 0.69  0.319  1.00  66.10

```

NOTE: PEAK FLOWS DO NOT INCLUDE BASEFLOWS IF ANY.

```

-----
| RESERVOIR( 0006) | OVERFLOW IS OFF
| IN= 2---> OUT= 1 |
| DT= 5.0 min |
-----
| OUTFLOW   STORAGE | OUTFLOW   STORAGE
| (cms)     (ha.m.) | (cms)     (ha.m.)
-----
| 0.0000    0.0000 | 0.0040    0.0220
| 0.0010    0.0030 | 0.0050    0.0380
| 0.0020    0.0060 | 0.0060    0.0500
| 0.0030    0.0130 | 0.0070    0.0510
-----
| AREA   QPEAK   TPEAK   R.V.
| (ha)   (cms)   (hrs)   (mm)
-----
| INFLOW : ID= 2 ( 0007) 0.693  0.319  1.00  66.10
| OUTFLOW: ID= 1 ( 0006) 0.693  0.005  3.00  65.01

```

PEAK FLOW REDUCTION [Qout/Qin](%)= 1.66
 TIME SHIFT OF PEAK FLOW (min)=120.00
 MAXIMUM STORAGE USED (ha.m.)= 0.0418

```

-----
| CALIB
| STANDHYD ( 0003) | Area (ha)= 0.06
| ID= 1 DT= 5.0 min | Total Imp(%)= 23.50 Dir. Conn.(%)= 23.50

```

		IMPERVIOUS	PERVIOUS (i)
Surface Area	(ha)=	0.01	0.05
Dep. Storage	(mm)=	1.00	1.50
Average Slope	(%)=	1.00	2.00
Length	(m)=	19.83	40.00
Mannings n	=	0.013	0.250

NOTE: RAINFALL WAS TRANSFORMED TO 5.0 MIN. TIME STEP.

----- TRANSFORMED HYETOGRAPH -----							
TIME	RAIN	TIME	RAIN	TIME	RAIN	TIME	RAIN
hrs	mm/hr	hrs	mm/hr	hrs	mm/hr	hrs	mm/hr
0.083	6.05	0.833	40.65	1.583	13.74	2.33	7.08
0.167	6.05	0.917	178.56	1.667	13.74	2.42	6.35
0.250	7.54	1.000	178.56	1.750	11.06	2.50	6.35
0.333	7.54	1.083	54.05	1.833	11.06	2.58	5.76
0.417	10.16	1.167	54.05	1.917	9.29	2.67	5.76
0.500	10.16	1.250	27.32	2.000	9.29	2.75	5.28
0.583	15.97	1.333	27.32	2.083	8.02	2.83	5.28
0.667	15.97	1.417	18.24	2.167	8.02	2.92	4.88
0.750	40.65	1.500	18.24	2.250	7.08	3.00	4.88

Max.Eff.Inten.(mm/hr)=	178.56	105.42
over (min)	5.00	10.00
Storage Coeff. (min)=	0.77 (ii)	7.68 (ii)
Unit Hyd. Tpeak (min)=	5.00	10.00
Unit Hyd. peak (cms)=	0.34	0.13

TOTALS

PEAK FLOW (cms)=	0.01	0.01	0.015 (iii)
TIME TO PEAK (hrs)=	1.00	1.08	1.00
RUNOFF VOLUME (mm)=	70.66	42.81	49.29
TOTAL RAINFALL (mm)=	71.66	71.66	71.66
RUNOFF COEFFICIENT =	0.99	0.60	0.69

***** WARNING: STORAGE COEFF. IS SMALLER THAN TIME STEP!

- (i) CN PROCEDURE SELECTED FOR PERVIOUS LOSSES:
CN* = 85.0 Ia = Dep. Storage (Above)
- (ii) TIME STEP (DT) SHOULD BE SMALLER OR EQUAL
THAN THE STORAGE COEFFICIENT.
- (iii) PEAK FLOW DOES NOT INCLUDE BASEFLOW IF ANY.

| ADD HYD (0004) |
1 + 2 = 3

AREA	QPEAK	TPEAK	R.V.
(ha)	(cms)	(hrs)	(mm)

ID1= 1 (0003):	0.06	0.015	1.00	49.29
+ ID2= 2 (0006):	0.69	0.005	3.00	65.01
=====				
ID = 3 (0004):	0.75	0.019	1.00	63.78

NOTE: PEAK FLOWS DO NOT INCLUDE BASEFLOWS IF ANY.

100-YR STORM + 20% POST DEVELOPMENT CONTROLLED

Outflow

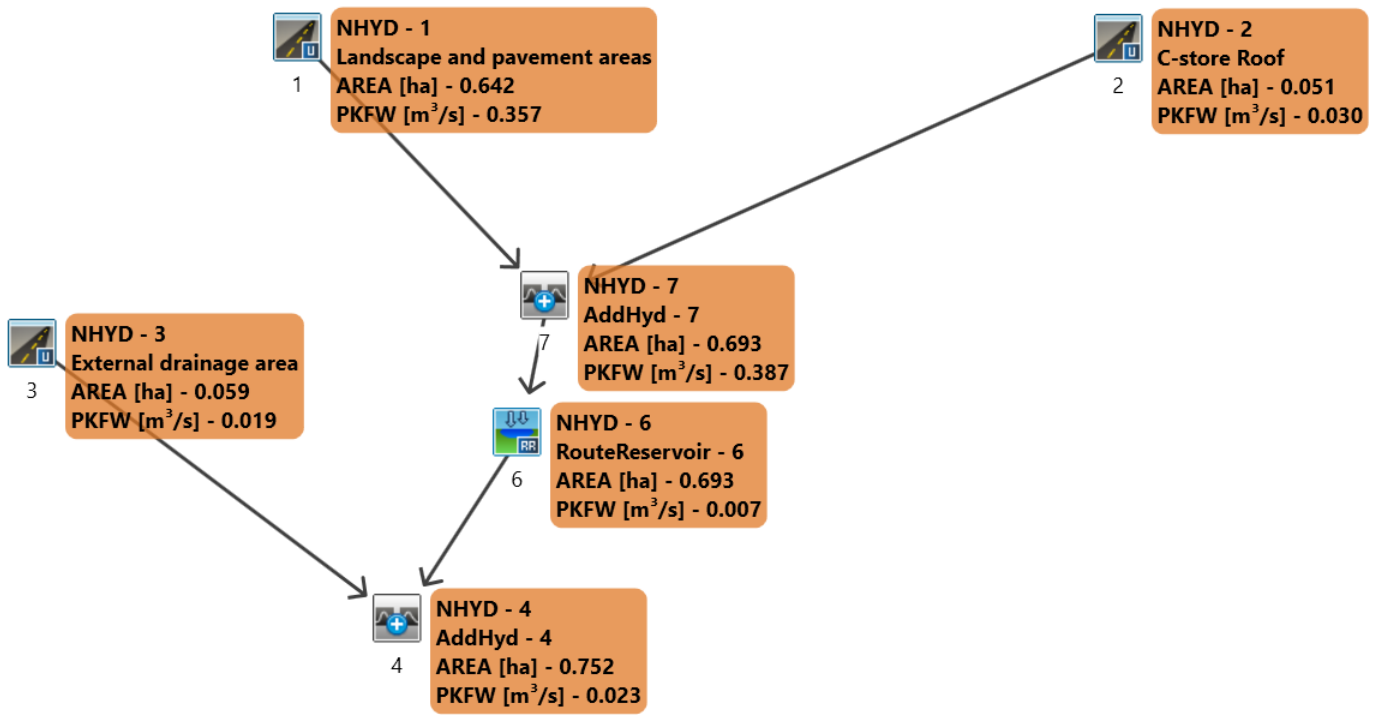

=====

V V I SSSSS U U A L (v 6.2.2005)
V V I SS U U A A L
V V I SS U U AAAAA L
V V I SS U U A A L
VV I SSSSS UUUUU A A LLLLL

000 TTTTT TTTTT H H Y Y M M 000 TM
0 0 T T H H Y Y MM MM 0 0
0 0 T T H H Y M M 0 0
000 T T H H Y M M 000

Developed and Distributed by Smart City Water Inc
Copyright 2007 - 2021 Smart City Water Inc
All rights reserved.

***** D E T A I L E D O U T P U T *****

Input filename: C:\Program Files (x86)\Visual OTTHYMO 6.2\V02\voin.dat

Output filename:

C:\Users\LiMing\AppData\Local\Civica\VH5\90c30b05-cee4-4f42-8939-ca4273b1ea06\4be1e7a9-404d-45bc-95d0-4b2260c10b49\scena

Summary filename:

C:\Users\LiMing\AppData\Local\Civica\VH5\90c30b05-cee4-4f42-8939-ca4273b1ea06\4be1e7a9-404d-45bc-95d0-4b2260c10b49\scena

DATE: 09/24/2021

TIME: 04:52:30

USER:

COMMENTS: _____

** SIMULATION : Chicago Design Storm - 100yr **

| CHICAGO STORM |
Ptotal= 86.00 mm

IDF curve parameters: A=2082.830
B= 6.014
C= 0.820

used in: INTENSITY = A / (t + B)^C

Duration of storm = 3.00 hrs
 Storm time step = 10.00 min
 Time to peak ratio = 0.33

TIME	RAIN	TIME	RAIN	TIME	RAIN	TIME	RAIN
hrs	mm/hr	hrs	mm/hr	hrs	mm/hr	hrs	mm/hr
0.17	7.25	1.00	214.27	1.83	13.27	2.67	6.91
0.33	9.05	1.17	64.86	2.00	11.14	2.83	6.34
0.50	12.19	1.33	32.78	2.17	9.63	3.00	5.85
0.67	19.16	1.50	21.89	2.33	8.50		
0.83	48.79	1.67	16.48	2.50	7.62		

```

-----
| CALIB          |
| STANDHYD ( 0001) |
| ID= 1 DT= 5.0 min |
-----
  
```

Area (ha)= 0.64
 Total Imp(%)= 82.40 Dir. Conn.(%)= 82.40

	IMPERVIOUS	PERVIOUS (i)
Surface Area (ha)=	0.53	0.11
Dep. Storage (mm)=	1.00	1.50
Average Slope (%)=	1.00	2.00
Length (m)=	65.42	40.00
Mannings n =	0.013	0.250

NOTE: RAINFALL WAS TRANSFORMED TO 5.0 MIN. TIME STEP.

----- TRANSFORMED HYETOGRAPH -----

TIME	RAIN	TIME	RAIN	TIME	RAIN	TIME	RAIN
hrs	mm/hr	hrs	mm/hr	hrs	mm/hr	hrs	mm/hr
0.083	7.25	0.833	48.79	1.583	16.48	2.33	8.50
0.167	7.25	0.917	214.27	1.667	16.48	2.42	7.62
0.250	9.05	1.000	214.27	1.750	13.27	2.50	7.62
0.333	9.05	1.083	64.86	1.833	13.27	2.58	6.91
0.417	12.19	1.167	64.86	1.917	11.14	2.67	6.91
0.500	12.19	1.250	32.78	2.000	11.14	2.75	6.34
0.583	19.16	1.333	32.78	2.083	9.63	2.83	6.34
0.667	19.16	1.417	21.89	2.167	9.63	2.92	5.85
0.750	48.79	1.500	21.89	2.250	8.50	3.00	5.85

Max.Eff.Inten.(mm/hr)=	214.27	138.07
over (min)	5.00	5.00
Storage Coeff. (min)=	1.46 (ii)	4.27 (ii)
Unit Hyd. Tpeak (min)=	5.00	5.00
Unit Hyd. peak (cms)=	0.33	0.23

TOTALS

PEAK FLOW	(cms)=	0.31	0.04	0.357 (iii)
TIME TO PEAK	(hrs)=	1.00	1.00	1.00
RUNOFF VOLUME	(mm)=	85.00	55.21	79.75
TOTAL RAINFALL	(mm)=	86.00	86.00	86.00
RUNOFF COEFFICIENT	=	0.99	0.64	0.93

***** WARNING: STORAGE COEFF. IS SMALLER THAN TIME STEP!

- (i) CN PROCEDURE SELECTED FOR PERVIOUS LOSSES:
CN* = 85.0 Ia = Dep. Storage (Above)
- (ii) TIME STEP (DT) SHOULD BE SMALLER OR EQUAL
THAN THE STORAGE COEFFICIENT.
- (iii) PEAK FLOW DOES NOT INCLUDE BASEFLOW IF ANY.

```

-----
| CALIB |
| STANDHYD ( 0002) | Area (ha)= 0.05
| ID= 1 DT= 5.0 min | Total Imp(%)= 99.00 Dir. Conn.(%)= 99.00
-----

```

		IMPERVIOUS	PERVIOUS (i)
Surface Area	(ha)=	0.05	0.00
Dep. Storage	(mm)=	1.00	1.50
Average Slope	(%)=	1.00	2.00
Length	(m)=	18.44	40.00
Mannings n	=	0.013	0.250

NOTE: RAINFALL WAS TRANSFORMED TO 5.0 MIN. TIME STEP.

```

----- TRANSFORMED HYETOGRAPH -----

```

TIME	RAIN	TIME	RAIN	TIME	RAIN	TIME	RAIN
hrs	mm/hr	hrs	mm/hr	hrs	mm/hr	hrs	mm/hr
0.083	7.25	0.833	48.79	1.583	16.48	2.33	8.50
0.167	7.25	0.917	214.27	1.667	16.48	2.42	7.62
0.250	9.05	1.000	214.27	1.750	13.27	2.50	7.62
0.333	9.05	1.083	64.86	1.833	13.27	2.58	6.91
0.417	12.19	1.167	64.86	1.917	11.14	2.67	6.91
0.500	12.19	1.250	32.78	2.000	11.14	2.75	6.34
0.583	19.16	1.333	32.78	2.083	9.63	2.83	6.34
0.667	19.16	1.417	21.89	2.167	9.63	2.92	5.85
0.750	48.79	1.500	21.89	2.250	8.50	3.00	5.85

Max.Eff.Inten.(mm/hr)=	214.27	138.07
over (min)	5.00	5.00
Storage Coeff. (min)=	0.68 (ii)	1.51 (ii)
Unit Hyd. Tpeak (min)=	5.00	5.00
Unit Hyd. peak (cms)=	0.34	0.33

PEAK FLOW	(cms)=	0.03	0.00	*TOTALS*	0.030 (iii)
-----------	--------	------	------	----------	-------------

TIME TO PEAK	(hrs)=	1.00	1.00	1.00
RUNOFF VOLUME	(mm)=	85.00	55.21	84.70
TOTAL RAINFALL	(mm)=	86.00	86.00	86.00
RUNOFF COEFFICIENT	=	0.99	0.64	0.98

***** WARNING: STORAGE COEFF. IS SMALLER THAN TIME STEP!

- (i) CN PROCEDURE SELECTED FOR PERVIOUS LOSSES:
CN* = 85.0 Ia = Dep. Storage (Above)
- (ii) TIME STEP (DT) SHOULD BE SMALLER OR EQUAL
THAN THE STORAGE COEFFICIENT.
- (iii) PEAK FLOW DOES NOT INCLUDE BASEFLOW IF ANY.

```

-----
| ADD HYD ( 0007) |
| 1 + 2 = 3 |
-----
| AREA   QPEAK   TPEAK   R.V.
| (ha)   (cms)   (hrs)   (mm)
-----
| ID1= 1 ( 0001): 0.64  0.357  1.00  79.75
| + ID2= 2 ( 0002): 0.05  0.030  1.00  84.70
|=====
| ID = 3 ( 0007): 0.69  0.387  1.00  80.12

```

NOTE: PEAK FLOWS DO NOT INCLUDE BASEFLOWS IF ANY.

```

-----
| RESERVOIR( 0006) | OVERFLOW IS OFF
| IN= 2---> OUT= 1 |
| DT= 5.0 min |
-----
| OUTFLOW   STORAGE | OUTFLOW   STORAGE
| (cms)     (ha.m.) | (cms)     (ha.m.)
-----
| 0.0000    0.0000 | 0.0040    0.0220
| 0.0010    0.0030 | 0.0050    0.0380
| 0.0020    0.0060 | 0.0060    0.0500
| 0.0030    0.0130 | 0.0070    0.0510

```

	AREA (ha)	QPEAK (cms)	TPEAK (hrs)	R.V. (mm)
INFLOW : ID= 2 (0007)	0.693	0.387	1.00	80.12
OUTFLOW: ID= 1 (0006)	0.693	0.007	3.00	79.03

PEAK FLOW REDUCTION [Qout/Qin](%)= 1.76
 TIME SHIFT OF PEAK FLOW (min)=120.00
 MAXIMUM STORAGE USED (ha.m.)= 0.0509

```

-----
| CALIB
| STANDHYD ( 0003) | Area (ha)= 0.06
| ID= 1 DT= 5.0 min | Total Imp(%)= 23.50 Dir. Conn.(%)= 23.50

```

		IMPERVIOUS	PERVIOUS (i)
Surface Area	(ha)=	0.01	0.05
Dep. Storage	(mm)=	1.00	1.50
Average Slope	(%)=	1.00	2.00
Length	(m)=	19.83	40.00
Mannings n	=	0.013	0.250

NOTE: RAINFALL WAS TRANSFORMED TO 5.0 MIN. TIME STEP.

----- TRANSFORMED HYETOGRAPH -----							
TIME	RAIN	TIME	RAIN	TIME	RAIN	TIME	RAIN
hrs	mm/hr	hrs	mm/hr	hrs	mm/hr	hrs	mm/hr
0.083	7.25	0.833	48.79	1.583	16.48	2.33	8.50
0.167	7.25	0.917	214.27	1.667	16.48	2.42	7.62
0.250	9.05	1.000	214.27	1.750	13.27	2.50	7.62
0.333	9.05	1.083	64.86	1.833	13.27	2.58	6.91
0.417	12.19	1.167	64.86	1.917	11.14	2.67	6.91
0.500	12.19	1.250	32.78	2.000	11.14	2.75	6.34
0.583	19.16	1.333	32.78	2.083	9.63	2.83	6.34
0.667	19.16	1.417	21.89	2.167	9.63	2.92	5.85
0.750	48.79	1.500	21.89	2.250	8.50	3.00	5.85

Max.Eff.Inten.(mm/hr)=	214.27	138.07
over (min)	5.00	10.00
Storage Coeff. (min)=	0.71 (ii)	6.92 (ii)
Unit Hyd. Tpeak (min)=	5.00	10.00
Unit Hyd. peak (cms)=	0.34	0.14

TOTALS

PEAK FLOW (cms)=	0.01	0.01	0.019 (iii)
TIME TO PEAK (hrs)=	1.00	1.08	1.00
RUNOFF VOLUME (mm)=	85.00	55.21	62.15
TOTAL RAINFALL (mm)=	86.00	86.00	86.00
RUNOFF COEFFICIENT =	0.99	0.64	0.72

***** WARNING: STORAGE COEFF. IS SMALLER THAN TIME STEP!

- (i) CN PROCEDURE SELECTED FOR PERVIOUS LOSSES:
CN* = 85.0 Ia = Dep. Storage (Above)
- (ii) TIME STEP (DT) SHOULD BE SMALLER OR EQUAL
THAN THE STORAGE COEFFICIENT.
- (iii) PEAK FLOW DOES NOT INCLUDE BASEFLOW IF ANY.

| ADD HYD (0004) |
| 1 + 2 = 3 |

AREA	QPEAK	TPEAK	R.V.
(ha)	(cms)	(hrs)	(mm)

ID1= 1 (0003):	0.06	0.019	1.00	62.15
+ ID2= 2 (0006):	0.69	0.007	3.00	79.03
=====				
ID = 3 (0004):	0.75	0.023	1.00	77.70

NOTE: PEAK FLOWS DO NOT INCLUDE BASEFLOWS IF ANY.

FINISH

=====

=====

Project Number: BRM-006060364-B0
 Circle K Nepean - 1545 Woodroffe Avenue, Ottawa, ON
 STORM SEWER DESIGN



Q=0.0028*C*I^A (cms)
 C : RUNOFF COEFFICIENT
 i : RAINFALL INTENSITY
 IDF Eqn : i = A / (B + T) ^C
 A : AREA (ha)

Town of Bradford	
IDF Parameter	10 yr
A =	1174.184
B =	6.014
C =	0.816

CALCULATION Sheet :11
 Date August 16, 2021

See DWG C04 for Drainage Areas	MAINTENANCE HOLE		LENGTH (m)	Total	Com. C	C _c A _T	TOTAL C _c	FLOW TIME (min)		I 10 _{yr} (mm/h)	TOTAL Q (cms)	S (%)	D (mm)	Q FULL (cms)	V FULL (m/s)	Sec. Time (sec)	Accum. Time (sec)
	FROM	TO		Area, A _T	C _c		A _T	TO	IN								
			(m)														
Area 201	CAR WASH	CB9	6.80	0.014	0.95	0.013	0.013	10.00	0.12	122.14	0.005	2.00	100	0.007	0.93	0.12	10.12
Area 202	CB9	CBMH6	29.0	0.043	0.25	0.011	0.024	10.12	0.40	121.39	0.008	1.00	250	0.059	1.21	0.40	10.52
Area 203	CB7	CBMH6	15.2	0.050	0.83	0.042	0.042	10.00	0.21	122.14	0.014	1.00	250	0.059	1.21	0.21	10.21
Area 204	CBMH6	CBMH5	28.7	0.175	0.84	0.147	0.226	10.52	0.35	118.99	0.075	1.00	300	0.097	1.37	0.35	10.87
Area 205	CBMH5	CBMH3	48.1	0.069	0.90	0.062	0.288	10.87	0.43	116.98	0.094	1.82	300	0.130	1.85	0.43	11.30
Area 208	CANOPY	CB4	53.7	0.042	0.95	0.040	0.040	10.00	0.86	122.14	0.014	1.00	200	0.033	1.04	0.86	10.86
Area 207	CB4	CBMH3	20.2	0.094	0.80	0.075	0.115	10.86	0.20	117.05	0.038	2.00	250	0.084	1.71	0.20	11.05
Area 206	CBMH3	CHAMBER MH2	3.8	0.119	0.89	0.106	0.509	11.30	0.03	114.58	0.163	2.00	375	0.248	2.25	0.03	11.33
	CHAMBER		3.8	0.000	0.00	0.000	0.509	11.33	0.03	114.43	0.163	2.00	375	0.248	2.25	0.03	11.36
Area 210	STORE	CBMH8	8.7	0.051	0.95	0.048	0.048	10.00	0.12	122.14	0.017	2.00	150	0.022	1.22	0.12	10.12
Area 209	CBMH8	MH2	17.7	0.036	0.32	0.012	0.060	10.12	0.20	121.41	0.020	1.43	250	0.071	1.45	0.20	10.32
-	MH2	STC EFO6	3.3			0.000	0.569	11.36	0.02	114.28	0.182	2.00	375	0.248	2.25	0.02	11.39
								Controlled Flow (See Calculation Sheet 10) =			0.026	2.00	375	0.248	2.25	0.02	11.39
-	STC EFO6	MH1	3.3					11.39	0.02	114.14	0.026	2.00	375	0.248	2.25	0.02	11.41
-	MH1	EX STM MH	15.5					11.41	0.09	114.01	0.026	3.00	375	0.304	2.75	0.09	11.50

Stormceptor® **EF** Sizing Report

STORMCEPTOR®

ESTIMATED NET ANNUAL SEDIMENT (TSS) LOAD REDUCTION

04/27/2021

Province:	Ontario
City:	Nepean
Nearest Rainfall Station:	OTTAWA MACDONALD-CARTIER INT'L AP
NCDC Rainfall Station Id:	6000
Years of Rainfall Data:	37

Project Name:	CK-Nepean
Project Number:	45153
Designer Name:	Leanna Badke
Designer Company:	EXP Services Inc.
Designer Email:	leanna.badke@exp.com
Designer Phone:	416-807-4187
EOR Name:	
EOR Company:	
EOR Email:	
EOR Phone:	

Site Name:	
------------	--

Drainage Area (ha):	0.82
Runoff Coefficient 'c':	0.75

Particle Size Distribution:	Fine
Target TSS Removal (%):	80.0

Required Water Quality Runoff Volume Capture (%):	90.00
Estimated Water Quality Flow Rate (L/s):	22.23
Oil / Fuel Spill Risk Site?	Yes
Upstream Flow Control?	Yes
Upstream Orifice Control Flow Rate to Stormceptor (L/s):	26.06
Peak Conveyance (maximum) Flow Rate (L/s):	
Site Sediment Transport Rate (kg/ha/yr):	

Net Annual Sediment (TSS) Load Reduction Sizing Summary	
Stormceptor Model	TSS Removal Provided (%)
EFO4	75
EFO6	83
EFO8	87
EFO10	90
EFO12	92

Recommended Stormceptor EFO Model: EFO6
Estimated Net Annual Sediment (TSS) Load Reduction (%): 83
Water Quality Runoff Volume Capture (%): > 90



Stormceptor® EF Sizing Report

THIRD-PARTY TESTING AND VERIFICATION

► **Stormceptor® EF and Stormceptor® EFO** are the latest evolutions in the Stormceptor® oil-grit separator (OGS) technology series, and are designed to remove a wide variety of pollutants from stormwater and snowmelt runoff. These technologies have been third-party tested in accordance with the Canadian ETV **Procedure for Laboratory Testing of Oil-Grit Separators** and performance has been third-party verified in accordance with the **ISO 14034 Environmental Technology Verification (ETV)** protocol.

PERFORMANCE

► **Stormceptor® EF and EFO** remove stormwater pollutants through gravity separation and floatation, and feature a patent-pending design that generates positive removal of total suspended solids (TSS) throughout each storm event, including high-intensity storms. Captured pollutants include sediment, free oils, and sediment-bound pollutants such as nutrients, heavy metals, and petroleum hydrocarbons. Stormceptor is sized to remove a high level of TSS from the frequent rainfall events that contribute the vast majority of annual runoff volume and pollutant load. The technology incorporates an internal bypass to convey excessive stormwater flows from high-intensity storms through the device without resuspension and washout (scour) of previously captured pollutants. Proper routine maintenance ensures high pollutant removal performance and protection of downstream waterways.

PARTICLE SIZE DISTRIBUTION (PSD)

► The **Canadian ETV PSD** shown in the table below was used, or in part, for this sizing. This is the identical PSD that is referenced in the Canadian ETV **Procedure for Laboratory Testing of Oil-Grit Separators** for both sediment removal testing and scour testing. The Canadian ETV PSD contains a wide range of particle sizes in the sand and silt fractions, and is considered reasonably representative of the particle size fractions found in typical urban stormwater runoff.

Particle Size (µm)	Percent Less Than	Particle Size Fraction (µm)	Percent
1000	100	500-1000	5
500	95	250-500	5
250	90	150-250	15
150	75	100-150	15
100	60	75-100	10
75	50	50-75	5
50	45	20-50	10
20	35	8-20	15
8	20	5-8	10
5	10	2-5	5
2	5	<2	5

Stormceptor®EF Sizing Report

Upstream Flow Controlled Results

Rainfall Intensity (mm / hr)	Percent Rainfall Volume (%)	Cumulative Rainfall Volume (%)	Flow Rate (L/s)	Flow Rate (L/min)	Surface Loading Rate (L/min/m ²)	Removal Efficiency (%)	Incremental Removal (%)	Cumulative Removal (%)
1	51.3	51.3	1.71	103.0	39.0	93	47.7	47.7
2	8.7	60.0	3.42	205.0	78.0	90	7.8	55.5
3	5.8	65.8	5.13	308.0	117.0	86	5.0	60.5
4	4.6	70.4	6.84	410.0	156.0	81	3.7	64.3
5	4.2	74.6	8.55	513.0	195.0	77	3.2	67.5
6	3.2	77.8	10.26	615.0	234.0	73	2.3	69.8
7	2.6	80.4	11.97	718.0	273.0	70	1.8	71.7
8	2.4	82.8	13.68	821.0	312.0	66	1.6	73.2
9	1.9	84.7	15.39	923.0	351.0	63	1.2	74.4
10	1.6	86.3	17.10	1026.0	390.0	59	0.9	75.4
11	1.3	87.6	18.81	1128.0	429.0	57	0.7	76.1
12	1.1	88.7	20.52	1231.0	468.0	56	0.6	76.7
13	1.3	90.0	22.23	1334.0	507.0	55	0.7	77.4
14	1.1	91.1	23.94	1436.0	546.0	54	0.6	78.0
15	8.9	100.0	25.65	1539.0	585.0	53	4.7	82.7
16	0.0	100.0	26.00	1560.0	593.0	52	0.0	82.7
17	0.0	100.0	26.00	1560.0	593.0	52	0.0	82.7
18	0.0	100.0	26.00	1560.0	593.0	52	0.0	82.7
19	0.0	100.0	26.00	1560.0	593.0	52	0.0	82.7
20	0.0	100.0	26.00	1560.0	593.0	52	0.0	82.7
21	0.0	100.0	26.00	1560.0	593.0	52	0.0	82.7
22	0.0	100.0	26.00	1560.0	593.0	52	0.0	82.7
23	0.0	100.0	26.00	1560.0	593.0	52	0.0	82.7
24	0.0	100.0	26.00	1560.0	593.0	52	0.0	82.7
25	0.0	100.0	26.00	1560.0	593.0	52	0.0	82.7



Stormceptor®EF Sizing Report

Rainfall Intensity (mm / hr)	Percent Rainfall Volume (%)	Cumulative Rainfall Volume (%)	Flow Rate (L/s)	Flow Rate (L/min)	Surface Loading Rate (L/min/m ²)	Removal Efficiency (%)	Incremental Removal (%)	Cumulative Removal (%)
26	0.0	100.0	26.00	1560.0	593.0	52	0.0	82.7
27	0.0	100.0	26.00	1560.0	593.0	52	0.0	82.7
28	0.0	100.0	26.00	1560.0	593.0	52	0.0	82.7
29	0.0	100.0	26.00	1560.0	593.0	52	0.0	82.7
30	0.0	100.0	26.00	1560.0	593.0	52	0.0	82.7
31	0.0	100.0	26.00	1560.0	593.0	52	0.0	82.7
32	0.0	100.0	26.00	1560.0	593.0	52	0.0	82.7
33	0.0	100.0	26.00	1560.0	593.0	52	0.0	82.7
34	0.0	100.0	26.00	1560.0	593.0	52	0.0	82.7
35	0.0	100.0	26.00	1560.0	593.0	52	0.0	82.7
36	0.0	100.0	26.00	1560.0	593.0	52	0.0	82.7
37	0.0	100.0	26.00	1560.0	593.0	52	0.0	82.7
38	0.0	100.0	26.00	1560.0	593.0	52	0.0	82.7
39	0.0	100.0	26.00	1560.0	593.0	52	0.0	82.7
40	0.0	100.0	26.00	1560.0	593.0	52	0.0	82.7
41	0.0	100.0	26.00	1560.0	593.0	52	0.0	82.7
42	0.0	100.0	26.00	1560.0	593.0	52	0.0	82.7
43	0.0	100.0	26.00	1560.0	593.0	52	0.0	82.7
44	0.0	100.0	26.00	1560.0	593.0	52	0.0	82.7
45	0.0	100.0	26.00	1560.0	593.0	52	0.0	82.7
46	0.0	100.0	26.00	1560.0	593.0	52	0.0	82.7
47	0.0	100.0	26.00	1560.0	593.0	52	0.0	82.7
48	0.0	100.0	26.00	1560.0	593.0	52	0.0	82.7
49	0.0	100.0	26.00	1560.0	593.0	52	0.0	82.7
50	0.0	100.0	26.00	1560.0	593.0	52	0.0	82.7
Estimated Net Annual Sediment (TSS) Load Reduction =								83 %



Stormceptor® EF Sizing Report

RAINFALL DATA FROM OTTAWA MACDONALD-CARTIER INT'L AP RAINFALL STATION

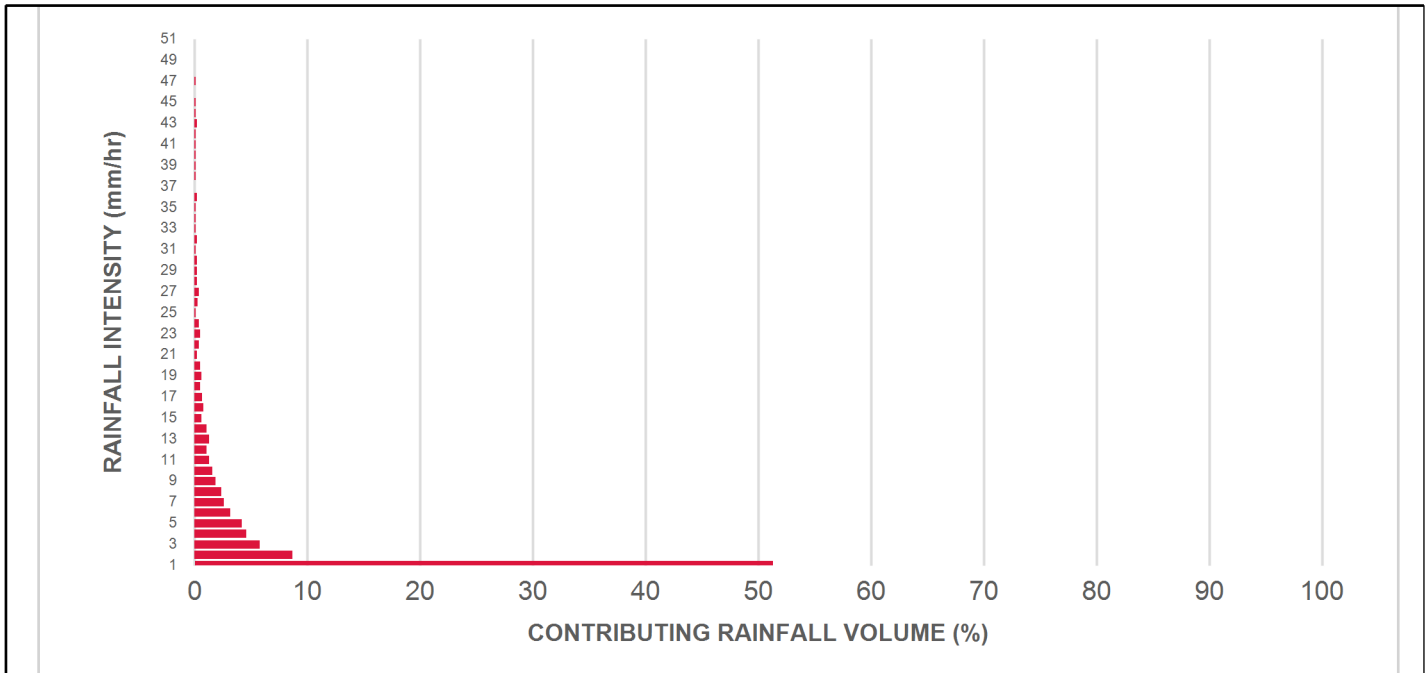

INCREMENTAL AND CUMULATIVE TSS REMOVAL FOR THE RECOMMENDED STORMCEPTOR® MODEL

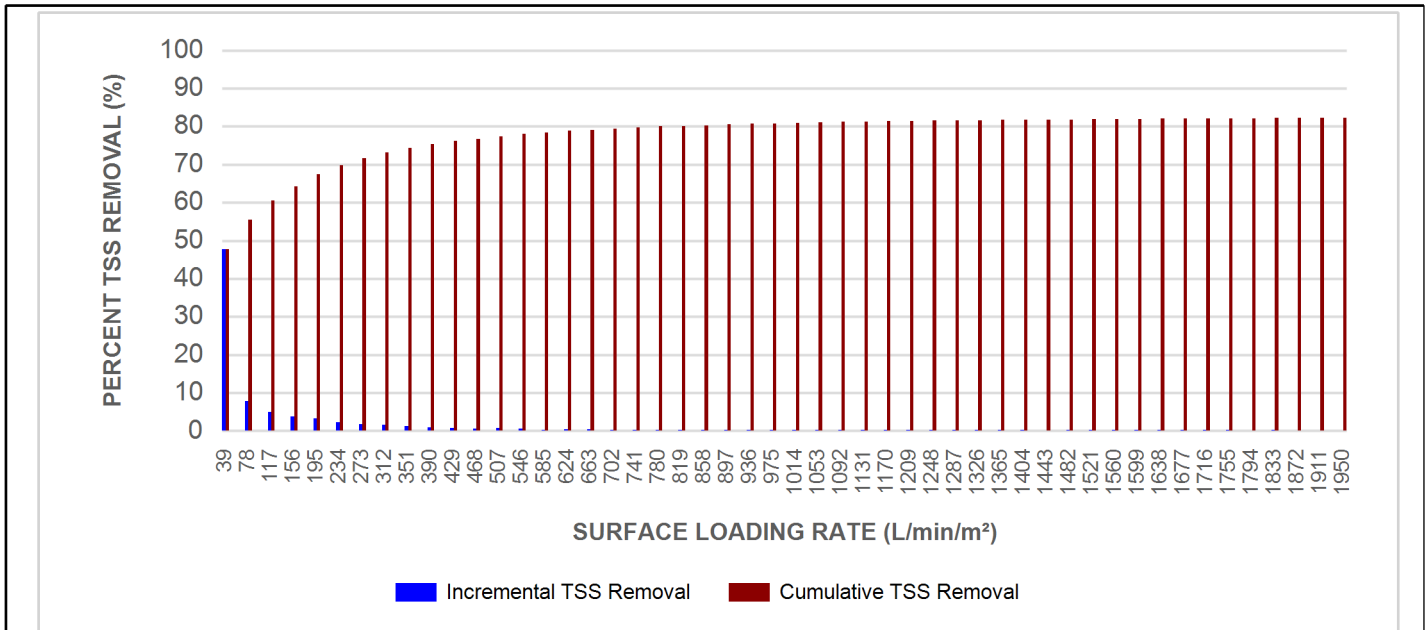

Stormceptor® EF Sizing Report

Maximum Pipe Diameter / Peak Conveyance

Stormceptor EF / EFO	Model Diameter		Min Angle Inlet / Outlet Pipes	Max Inlet Pipe Diameter		Max Outlet Pipe Diameter		Peak Conveyance Flow Rate	
	(m)	(ft)		(mm)	(in)	(mm)	(in)	(L/s)	(cfs)
EF4 / EFO4	1.2	4	90	609	24	609	24	425	15
EF6 / EFO6	1.8	6	90	914	36	914	36	990	35
EF8 / EFO8	2.4	8	90	1219	48	1219	48	1700	60
EF10 / EFO10	3.0	10	90	1828	72	1828	72	2830	100
EF12 / EFO12	3.6	12	90	1828	72	1828	72	2830	100

SCOUR PREVENTION AND ONLINE CONFIGURATION

► Stormceptor® EF and EFO feature an internal bypass and superior scour prevention technology that have been demonstrated in third-party testing according to the scour testing provisions of the Canadian ETV **Procedure for Laboratory Testing of Oil-Grit Separators**, and the exceptional scour test performance has been third-party verified in accordance with the ISO 14034 ETV protocol. As a result, Stormceptor EF and EFO are approved for online installation, eliminating the need for costly additional bypass structures, piping, and installation expense.

DESIGN FLEXIBILITY

► Stormceptor® EF and EFO offers design flexibility in one simplified platform, accepting stormwater flow from a single inlet pipe or multiple inlet pipes, and/or surface runoff through an inlet grate. The device can also serve as a junction structure, accommodate a 90-degree inlet-to-outlet bend angle, and can be modified to ensure performance in submerged conditions.

OIL CAPTURE AND RETENTION

► While Stormceptor® EF will capture and retain oil from dry weather spills and low intensity runoff, Stormceptor® EFO has demonstrated superior oil capture and greater than 99% oil retention in third-party testing according to the light liquid re-entrainment testing provisions of the Canadian ETV **Procedure for Laboratory Testing of Oil-Grit Separators**. Stormceptor EFO is recommended for sites where oil capture and retention is a requirement.

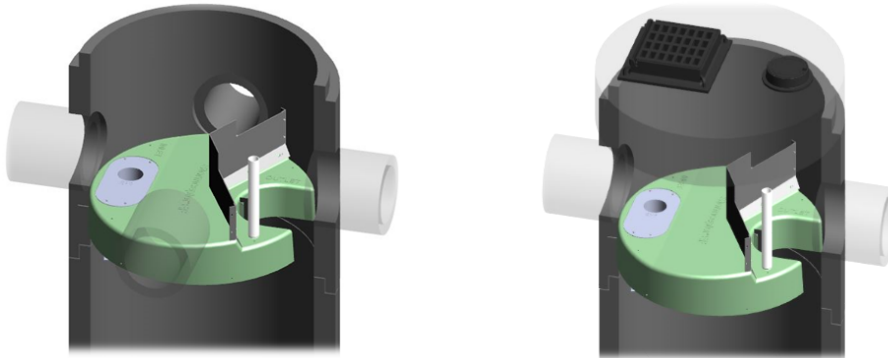

Stormceptor® EF Sizing Report

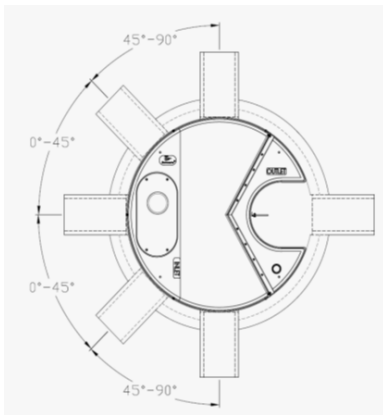

INLET-TO-OUTLET DROP

Elevation differential between inlet and outlet pipe inverts is dictated by the angle at which the inlet pipe(s) enters the unit.

0° - 45° : The inlet pipe is 1-inch (25mm) higher than the outlet pipe.

45° - 90° : The inlet pipe is 2-inches (50mm) higher than the outlet pipe.

HEAD LOSS

The head loss through Stormceptor EF is similar to that of a 60-degree bend structure. The applicable K value for calculating minor losses through the unit is 1.1.

For submerged conditions the applicable K value is 3.0.

Pollutant Capacity

Stormceptor EF / EFO	Model Diameter		Depth (Outlet Pipe Invert to Sump Floor)		Oil Volume		Recommended Sediment Maintenance Depth *		Maximum Sediment Volume *		Maximum Sediment Mass **	
	(m)	(ft)	(m)	(ft)	(L)	(Gal)	(mm)	(in)	(L)	(ft³)	(kg)	(lb)
EF4 / EFO4	1.2	4	1.52	5.0	265	70	203	8	1190	42	1904	5250
EF6 / EFO6	1.8	6	1.93	6.3	610	160	305	12	3470	123	5552	15375
EF8 / EFO8	2.4	8	2.59	8.5	1070	280	610	24	8780	310	14048	38750
EF10 / EFO10	3.0	10	3.25	10.7	1670	440	610	24	17790	628	28464	78500
EF12 / EFO12	3.6	12	3.89	12.8	2475	655	610	24	31220	1103	49952	137875

*Increased sump depth may be added to increase sediment storage capacity

** Average density of wet packed sediment in sump = 1.6 kg/L (100 lb/ft³)

Feature	Benefit	Feature Appeals To
Patent-pending enhanced flow treatment and scour prevention technology	Superior, verified third-party performance	Regulator, Specifying & Design Engineer
Third-party verified light liquid capture and retention for EFO version	Proven performance for fuel/oil hotspot locations	Regulator, Specifying & Design Engineer, Site Owner
Functions as bend, junction or inlet structure	Design flexibility	Specifying & Design Engineer
Minimal drop between inlet and outlet	Site installation ease	Contractor
Large diameter outlet riser for inspection and maintenance	Easy maintenance access from grade	Maintenance Contractor & Site Owner

STANDARD STORMCEPTOR EF/EFO DRAWINGS

For standard details, please visit <http://www.imbrium.com/stormwater-treatment-solutions/stormceptor-ef>

STANDARD STORMCEPTOR EF/EFO SPECIFICATION

For specifications, please visit <http://www.imbrium.com/stormwater-treatment-solutions/stormceptor-ef>

**STANDARD PERFORMANCE SPECIFICATION FOR
“OIL GRIT SEPARATOR” (OGS) STORMWATER QUALITY TREATMENT DEVICE**

PART 1 – GENERAL

1.1 WORK INCLUDED

This section specifies requirements for selecting, sizing, and designing an underground Oil Grit Separator (OGS) device for stormwater quality treatment, with third-party testing results and a Statement of Verification in accordance with ISO 14034 Environmental Management – Environmental Technology Verification (ETV).

1.2 REFERENCE STANDARDS & PROCEDURES

ISO 14034:2016 Environmental management – Environmental technology verification (ETV)

Canadian Environmental Technology Verification (ETV) Program’s **Procedure for Laboratory Testing of Oil-Grit Separators**

1.3 SUBMITTALS

1.3.1 All submittals, including sizing reports & shop drawings, shall be submitted upon request with each order to the contractor then forwarded to the Engineer of Record for review and acceptance. Shop drawings shall detail all OGS components, elevations, and sequence of construction.

1.3.2 Alternative devices shall have features identical to or greater than the specified device, including: treatment chamber diameter, treatment chamber wet volume, sediment storage volume, and oil storage volume.

1.3.3 Unless directed otherwise by the Engineer of Record, OGS stormwater quality treatment product substitutions or alternatives submitted within ten days prior to project bid shall not be accepted. All alternatives or substitutions submitted shall be signed and sealed by a local registered Professional Engineer, based on the exact same criteria detailed in Section 3, in entirety, subject to review and approval by the Engineer of Record.

PART 2 – PRODUCTS

2.1 OGS POLLUTANT STORAGE

The OGS device shall include a sump for sediment storage, and a protected volume for the capture and storage of petroleum hydrocarbons and buoyant gross pollutants. The minimum sediment & petroleum hydrocarbon storage capacity shall be as follows:

2.1.1	4 ft (1219 mm) Diameter OGS Units:	1.19 m ³ sediment / 265 L oil
	6 ft (1829 mm) Diameter OGS Units:	3.48 m ³ sediment / 609 L oil
	8 ft (2438 mm) Diameter OGS Units:	8.78 m ³ sediment / 1,071 L oil
	10 ft (3048 mm) Diameter OGS Units:	17.78 m ³ sediment / 1,673 L oil
	12 ft (3657 mm) Diameter OGS Units:	31.23 m ³ sediment / 2,476 L oil

PART 3 – PERFORMANCE & DESIGN

3.1 GENERAL

The OGS stormwater quality treatment device shall be verified in accordance with ISO 14034:2016 Environmental management – Environmental technology verification (ETV). The OGS stormwater quality treatment device shall



Stormceptor®EF Sizing Report

remove oil, sediment and gross pollutants from stormwater runoff during frequent wet weather events, and retain these pollutants during less frequent high flow wet weather events below the insert within the OGS for later removal during maintenance. The Manufacturer shall have at least ten (10) years of local experience, history and success in engineering design, manufacturing and production and supply of OGS stormwater quality treatment device systems, acceptable to the Engineer of Record.

3.2 SIZING METHODOLOGY

The OGS device shall be engineered, designed and sized to provide stormwater quality treatment based on treating a minimum of 90 percent of the average annual runoff volume and a minimum removal of an annual average 60% of the sediment (TSS) load based on the Particle Size Distribution (PSD) specified in the sizing report for the specified device. Sizing shall be determined using historical rainfall data and a sediment removal performance curve derived from the actual third-party verified laboratory testing data. The OGS device shall also have sufficient annual sediment storage capacity as specified and calculated in Section 2.1.

3.3 CANADIAN ETV or ISO 14034 ETV VERIFICATION OF SCOUR TESTING

The OGS device shall have Canadian ETV or ISO 14034 ETV Verification of third-party scour testing conducted in accordance with the Canadian ETV Program's **Procedure for Laboratory Testing of Oil-Grit Separators**.

3.3.1 To be acceptable for on-line installation, the OGS device must demonstrate an average scour test effluent concentration less than 10 mg/L at each surface loading rate tested, up to and including 2600 L/min/m².

3.4 LIGHT LIQUID RE-ENTRAINMENT SIMULATION TESTING

The OGS device shall have Canadian ETV or ISO 14034 ETV Verification of completed third-party Light Liquid Re-entrainment Simulation Testing in accordance with the Canadian ETV **Program's Procedure for Laboratory Testing of Oil-Grit Separators**, with results reported within the Canadian ETV or ISO 14034 ETV verification. This re-entrainment testing is conducted with the device pre-loaded with low density polyethylene (LDPE) plastic beads as a surrogate for light liquids such as oil and fuel. Testing is conducted on the same OGS unit tested for sediment removal to assess whether light liquids captured after a spill are effectively retained at high flow rates.

3.4.1 For an OGS device to be an acceptable stormwater treatment device on a site where vehicular traffic occurs and the potential for an oil or fuel spill exists, the OGS device must have reported verified performance results of greater than 99% cumulative retention of LDPE plastic beads for the five specified surface loading rates (ranging 200 L/min/m² to 2600 L/min/m²) in accordance with the Light Liquid Re-entrainment Simulation Testing within the Canadian ETV Program's **Procedure for Laboratory Testing of Oil-Grit Separators**. However, an OGS device shall not be allowed if the Light Liquid Re-entrainment Simulation Testing was performed with screening components within the OGS device that are effective at retaining the LDPE plastic beads, but would not be expected to retain light liquids such as oil and fuel.

Appendix D – Sanitary Design Calculations



City of Ottawa
 1545 Woodroffe Ave - Circle K
 Project Number: BRM-00606364-B0
 Sanitary Sewer Design Calculations

PIPE ROUGHNESS (n)		PEAKING FACTOR	
< 600	= 0.013	1.50	
≥ 600	= 0.013		
DESIGN VELOCITIES		P = Population in Thousands	
MIN =	0.60 m/s	FLOW FACTOR (L/day/square metre)	
MAX =	3.00 m/s	5	
MAXIMUM PIPE CAPACITY		INFILTRATION RATE (L/sec/ha)	
80%		0.26	

DESIGNED BY : M. Li 18-Aug-21
 REVISED BY :
 CHECKED BY : J. Stern

AREA	MANHOLE		Development Type	AREA		FLOW CHARACTERISTICS (L/sec)						PROPOSED SEWER DESIGN				ACTUAL VELOCITY PERMITTED FLOWING FULL (m/s)	PERCENT FULL (%)	ACTUAL VELOCITY (m/s)	ACTUAL DEPTH (m)	FROUDE NUMBER	DESIGN CHECKS	
	FROM	TO		INCREMENTAL (ha)	CUMMULATIVE (ha)	PEAK FACTOR	AVERAGE Q _{avg}	PEAK Q _{peak}	INFILTRATION Q _{inflt}	Foundation Q _{fdn}	TOTAL Q _{tot}	DIAMETRE (mm)	TYPE	GRADE (%)	CAPACITY (L/s)						MIN VELOCITY	MAX VELOCITY
1	CAR WASH	MH5A	Commercial	0.210	0.210	1.50	0.730	1.095	0.055	0.000	1.150	200	S. PVC	2.00	46.384	1.48	2.5%	0.59	0.02	1.33	OK	OK
2	MH5A	MH6A	Commercial	0.131	0.341	1.50	0.000	0.000	0.089	0.000	0.089	200	S. PVC	2.00	46.384	1.48	0.2%	0.11	0.00	0.70	OK	OK
4	STORE	MH7A	Commercial	0.098	0.098	1.50	0.029	0.044	0.025	0.000	0.069	200	S. PVC	2.00	46.384	1.48	0.1%	0.09	0.00	0.62	OK	OK
4	MH7A	MH6A	Commercial	0.046	0.144	1.50	0.000	0.000	0.037	0.000	0.037	200	S. PVC	2.00	46.384	1.48	0.1%	0.06	0.00	0.52	OK	OK
5	MH6A	MH4A	Commercial	0.248	0.733	1.50	0.000	0.000	0.191	0.000	0.191	200	S. PVC	2.00	46.384	1.48	0.4%	0.16	0.00	0.87	OK	OK
6	MH4A	MH3A	Commercial	0.053	0.786	1.50	0.000	0.000	0.204	0.000	0.204	200	S. PVC	2.00	46.384	1.48	0.4%	0.16	0.00	0.87	OK	OK
7	MH3A	MH2A	Commercial	0.037	0.823	1.50	0.000	0.000	0.214	0.000	0.214	200	S. PVC	1.25	36.670	1.17	0.6%	0.17	0.00	0.80	OK	OK
External	MH2A	MH1A	Commercial	0.000	0.823	1.50	0.000	0.000	0.214	0.000	0.214	200	S. PVC	2.00	46.384	1.48	0.5%	0.17	0.00	0.90	OK	OK

NOTES: 1) Foundation drains to the sanitary sewer system is not permitted for new developments. Therefore, no allowance is made for foundation drain flow.
 2) Total flow of 25.719 L/s is from External Sanitary Sewer Design Calculation

Design Parameters		
Population Density		
Single Family Dwelling, " R "	3.5	per / unit
Extraneous Flow, Infiltration	0.26	L/ sec / ha
Foundation Drain	NA	L/ sec / ha
Average Daily Flow, q	450	L/ capita / day

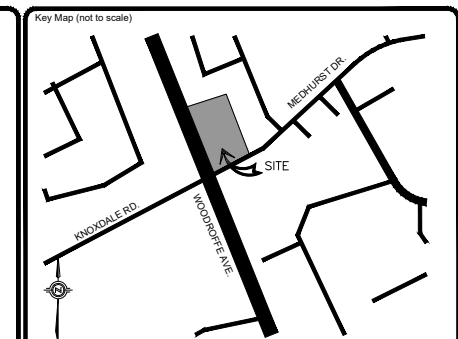
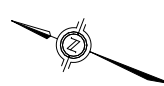
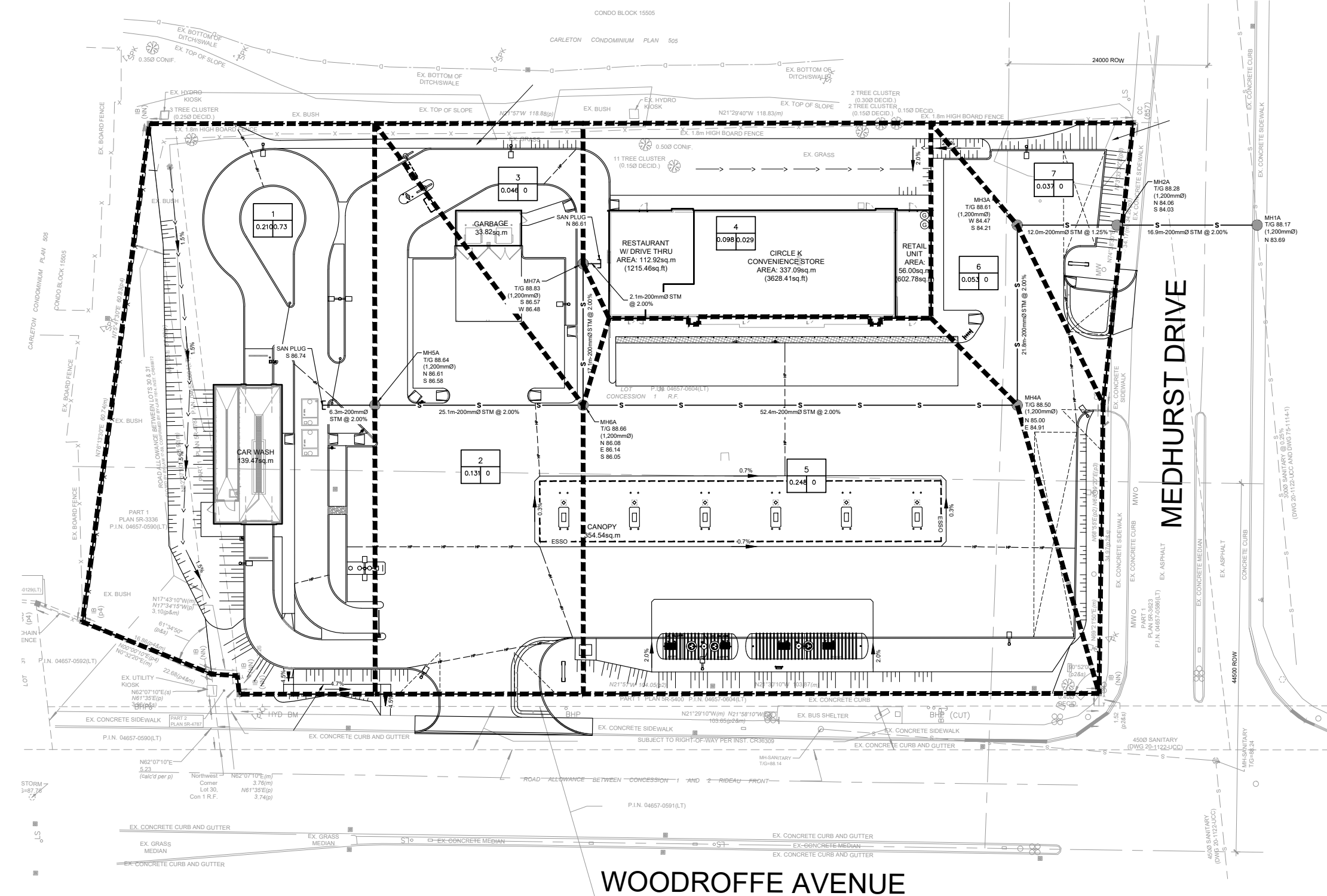

LEGEND:

- IRON BAR
- BENCHMARK
- EX. FIRE HYDRANT
- EX. LIGHT POLE
- EX. LIGHT STANDARD
- EX. STORM MH
- EX. SANITARY MH
- EX. STORM CB
- EX. WATER VALVE
- EX. VALVE CHAMBER
- EX. BELL & HYDRO POLE
- EX. GUY WIRE AND ANCHOR
- EX. TRAFFIC SIGNAL
- EX. GAS VALVE
- EX. SIGN
- EX. TREE

SUBJECT PROPERTY

- PROPERTY LINE
- EX. CONC. CURB
- EX. CENTERLINE OF DITCH
- EX. ROAD CENTERLINE
- EX. FENCE
- EX. STORM SEWER
- EX. CONTOUR
- NEW YARD LIGHT
- NEW STORM MH
- NEW SANITARY MH
- NEW STORM CB
- NEW STORM CBMH
- NEW CONC. CURB
- NEW CURB OUTSIDE-PRESSED CURB
- FIRE ROUTE SIGN
- NEW 1.8m HIGH WOOD FENCE

--- DRAINAGE AREA BOUNDARY

--- CATCHMENT I.D.

--- AREA (ha) | FACILITY FLOW

No.	REVISIONS	Date	By	App.
B	RE-ISSUED FOR SPA	SEPT 24 2021	ML	J.S.
A	ISSUED FOR SPA	AUG 25 2021	ML	J.S.

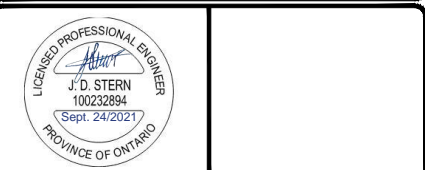

exp Services Inc.
 t: +1.905.793.9800 | f: +1.905.793.0641
 1595 Clark Boulevard
 Brampton, ON L6T 4V1
 Canada
 www.exp.com

- BUILDINGS • EARTH & ENVIRONMENT • ENERGY •
- INDUSTRIAL • INFRASTRUCTURE • SUSTAINABILITY •



Location:
1545 WOODROFFE AVE.
OTTAWA, ON

Title:
**POST-DEVELOPMENT
 SANITARY DRAINAGE
 AREA PLAN**

Designed By: M.L.	Drawn By: M.L.	Checked By: J.S.
Scale: 1:250	Date: APRIL 2020	City Drawing No.:
Project No.: BRM00606364-B0		Drawing No.: C07

CITY # DWG-12-21-0056