

ISSUED FOR SITE PLAN CONTROL APPLICATION

DECEMBER 17TH, 2019

MIXED-USE DEVELOPMENT

185-187 PRESTON ST. OTTAWA ONTARIO CANADA



STAMP:

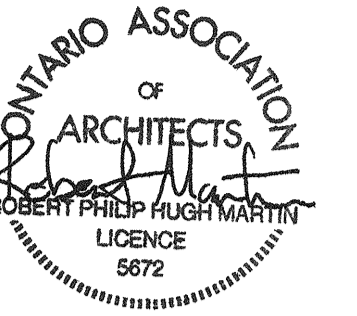

CLIENT:

ARCHITECTURAL DRAWING LIST

- A000 COVER PAGE
- A002 SITE PLAN AND LANDSCAPE PLAN
- A100 BASEMENT AND GROUND FLOOR PLAN
- A101 SECOND AND THIRD FLOOR PLAN
- A102 FOURTH FLOOR AND ROOF PLAN
- A200 BUILDING ELEVATIONS

CIVIL DRAWING LIST

- S-1 SERVICES PLAN
- S-2 EROSION & SEDIMENT CONTROL PLAN
- G-1 GRADING PLAN

SURVEY DRAWING

- 015-SRPR ORIGINAL SURVEY REPORT AND PROPERTY PLAN

KEYPLAN

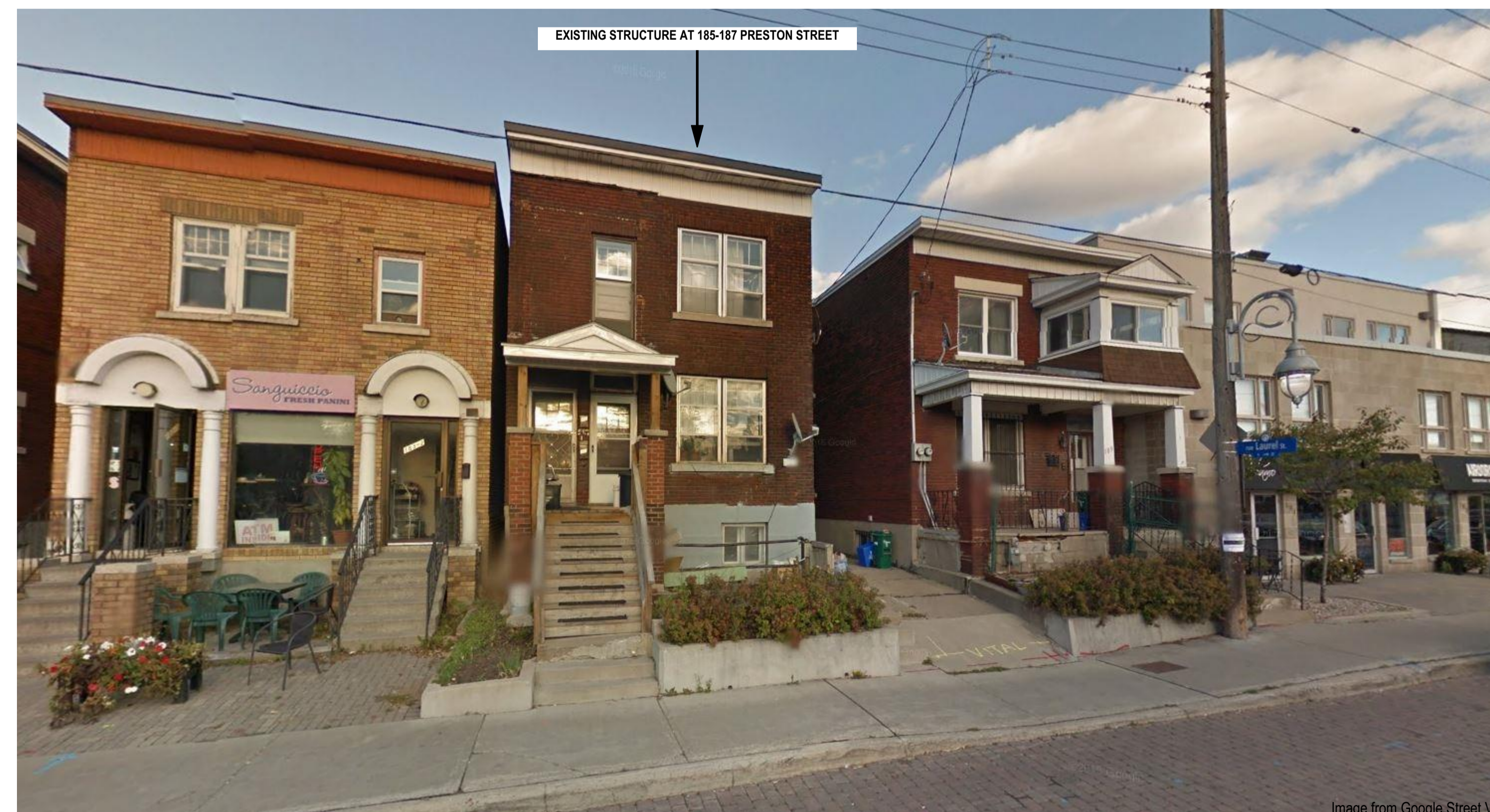
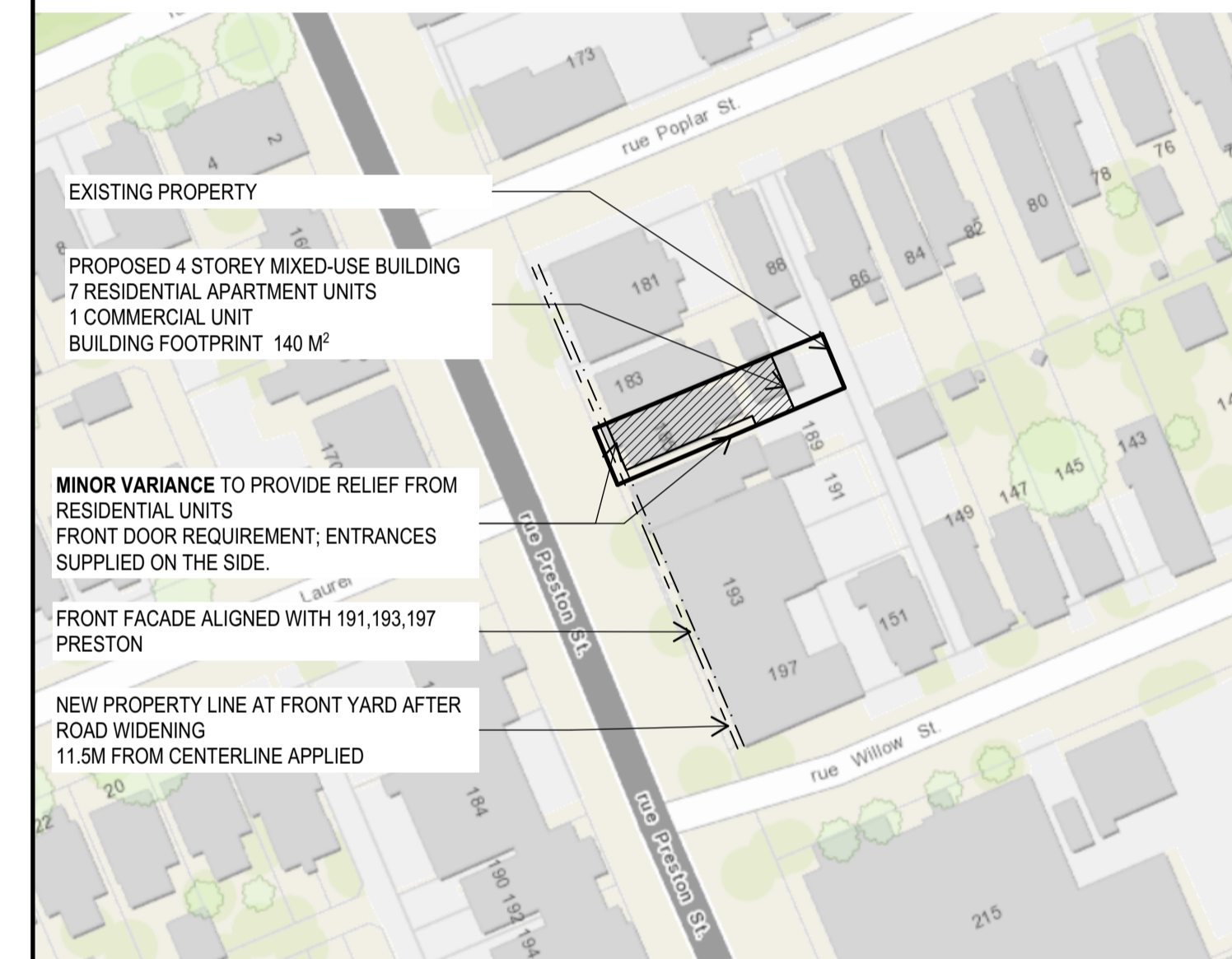

REVISIONS:

No.	DESCRIPTION	DATE
02	RE-ISSUED FOR SITE PLAN CONTROL	2020-01-10
01	ISSUED FOR SITE PLAN CONTROL	2019-12-18

DRAWINGS COPYRIGHT ROBERTSON MARTIN ARCHITECTS.

DO NOT COPY. DO NOT SCALE DRAWINGS. ALL DIMENSIONS TO BE CHECKED AND VERIFIED ON SITE.

NORTH:

PROJECT:

MIXED-USE DEVELOPMENT

185-187 PRESTON ST. OTTAWA ONTARIO CANADA

DRAWING:

COVER PAGE

DESIGNED BY: MCV/LB APPROVED BY: SR

DRAWN BY: MCV/FM

DATE: 2020-01-10 SCALE: AS NOTED

RMA PROJECT NUMBER SHEET NUMBER: 20024 A001

STAMP:



CLIENT:



6 CITY OF OTTAWA TREE INVENTORY

LANDSCAPING NOTES:

- THIS DEVELOPMENT HAS NO RELEVANT EXISTING LANDSCAPING AND THE CURRENT GREENERY IS OVERGROWTH FROM LACK OF MAINTENANCE.
- NEW PROPOSED PLANTERS WILL ADD UPDATED, STRUCTURED LANDSCAPING. PLANTS TO BE A MIX OF EVERGREEN AND DECIDUOUS PERENNIALS.
- PROPOSED TREE TO BE CANADIAN SERVICEBERRY / JUNE BERRY (AMELANCHIER CANADIENSIS).



5 GREENERY OVERGROWTH SINCE INITIAL PRE-CONSULTATION ON 2016

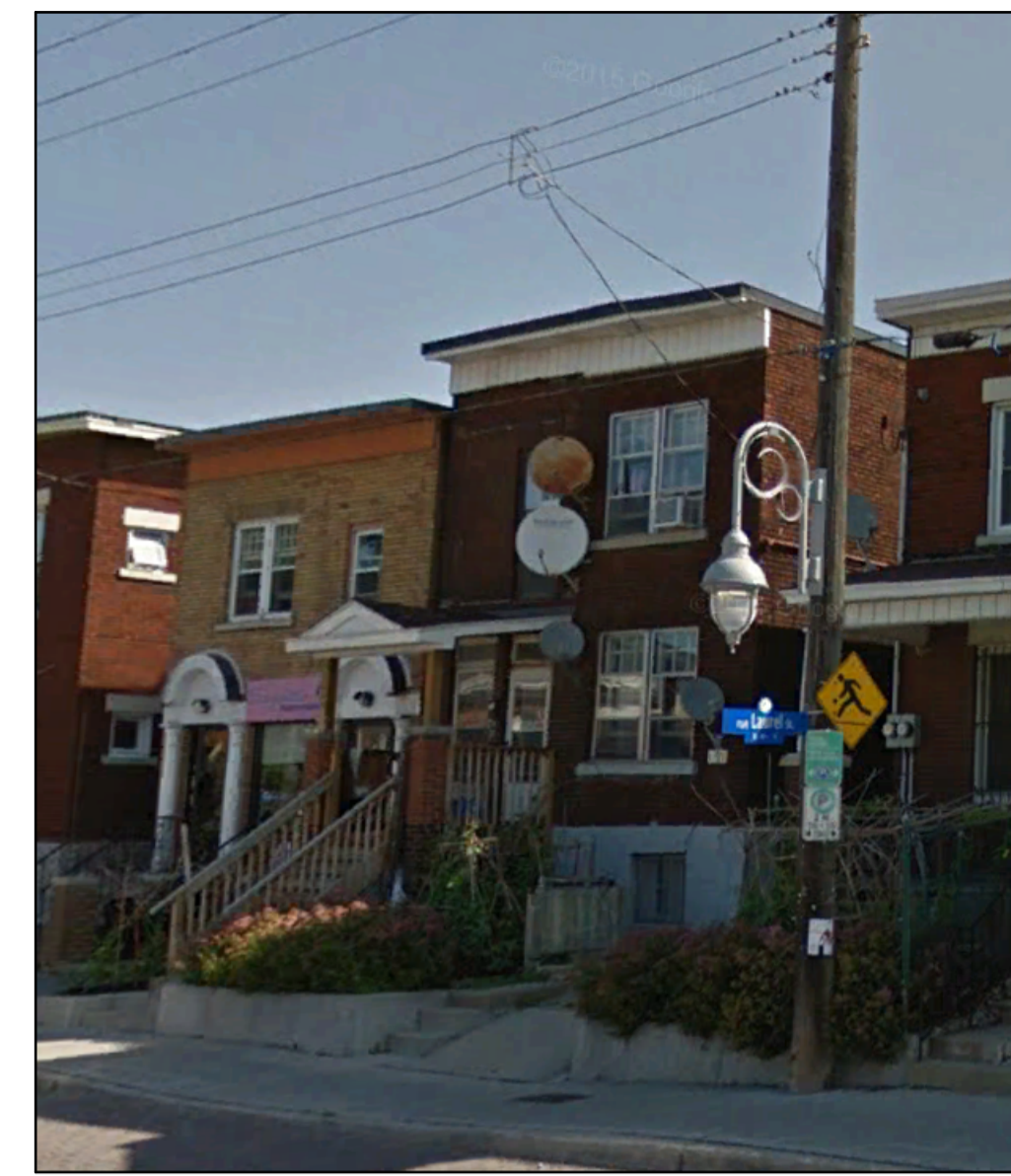

4 EXISTING PLANTERS & OVERHEAD WIRES

ZONING INFORMATION - TM [78] H15	REQUIRED	PROVIDED
LOT		(*)
LOT COVERAGE		230.2 m ²
MIN. LOT WIDTH	No min.	7.32 m
MIN. LOT AREA	No min.	230.2 m ²
MAX. BUILDING HEIGHT, from existing average grade	15 m	14.3 m
FRONT YARD SETBACK	2.00 m MAX. NO MIN.	2.00 m
REAR YARD SETBACK	7.50 m MIN.	7.50 m
SIDEYARD SETBACK	3.00 m MAX. NO MIN.	1.20m
MAXIMUM FLOOR SPACE INDEX	NO MAX.	
MIN. WIDTH OF LANDSCAPED AREA	NO MIN.	

Amenity:

Low-rise Apartment Dwelling of more than 4 units in any Zone other than a residential zone.
 6 m² per dwelling unit and 10% of gross floor area of each rooming unit. Minimum 50% communal.
 Aggregated into areas up to 54 m² if more than one provided 1, one must be 54 m²
 7 units x 6 m² = 42 m²
 Required amenity: 0 m² as per Table 197 "other uses"
 Provided: 76.5 m² (communal at roof top - 65.1 m², private at 3rd floor terrace 11.4m²)

Parking:

II Area A on Schedule 1 (Central Area) West of Rideau Canal
 Non-Residential : N/A; no parking required.
 Residential : N/A; West of Rideau Canal.
 No Parking required. Provided: 1

Bicycle Parking rates (Table 111A)

(b) (i) apartment building, low rise, apartment building = 0.5 per unit.
 0.5 x 7 units = (3.5) spaces.
 (e) Restaurant / Retail = 1 per 250m²
 102m²/250m² = .4 Therefore = (0)
 Bicycle required 4. Provided: 4

(*) SITE PLAN INFORMATION BASED ON

Part of Lot 4
 Registered Plan No.62
 PIN 04108-0178 (LT)
 City of Ottawa
 By J.D. Barnes Ltd. April 20, 2016

WASTE COLLECTION NOTE:

- THIS DEVELOPMENT WILL BE ON A MULTI-RESIDENTIAL FRONT END BIN SERVICE BY THE CITY OF OTTAWA FOR WASTE AND GARBAGE. 3 x 360L BINS HAS BEEN PROVIDED FOR GARBAGE FOR THE RESIDENTIAL UNITS AND 2-YARD BIN HAS BEEN PROVIDED FOR GARBAGE FOR THE COMMERCIAL UNIT.
- RECYCLING CONTAINERS WILL BE ROLLED TO THE STREET FOR COLLECTION BY THE PROPERTY MANAGEMENT. 2 x 360L BINS WILL BE PROVIDED.

GROSS FLOOR AREA:

BASEMENT:	133 m ²
GROUND:	133.5 m ²
SECOND:	139.5 m ²
THIRD:	123.8 m ²
FOURTH:	121 m ²
TOTAL:	652.8 m ²

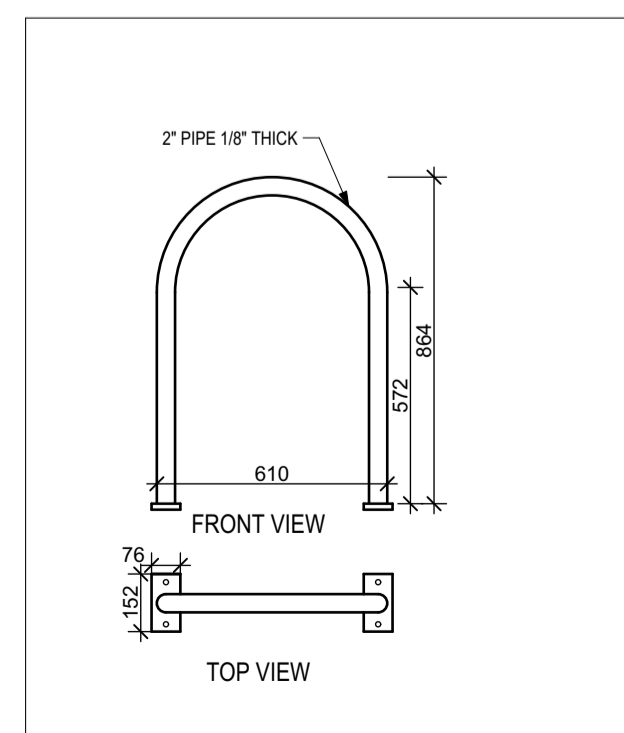

3 BIKE RACK DETAIL

SCALE: 1:20

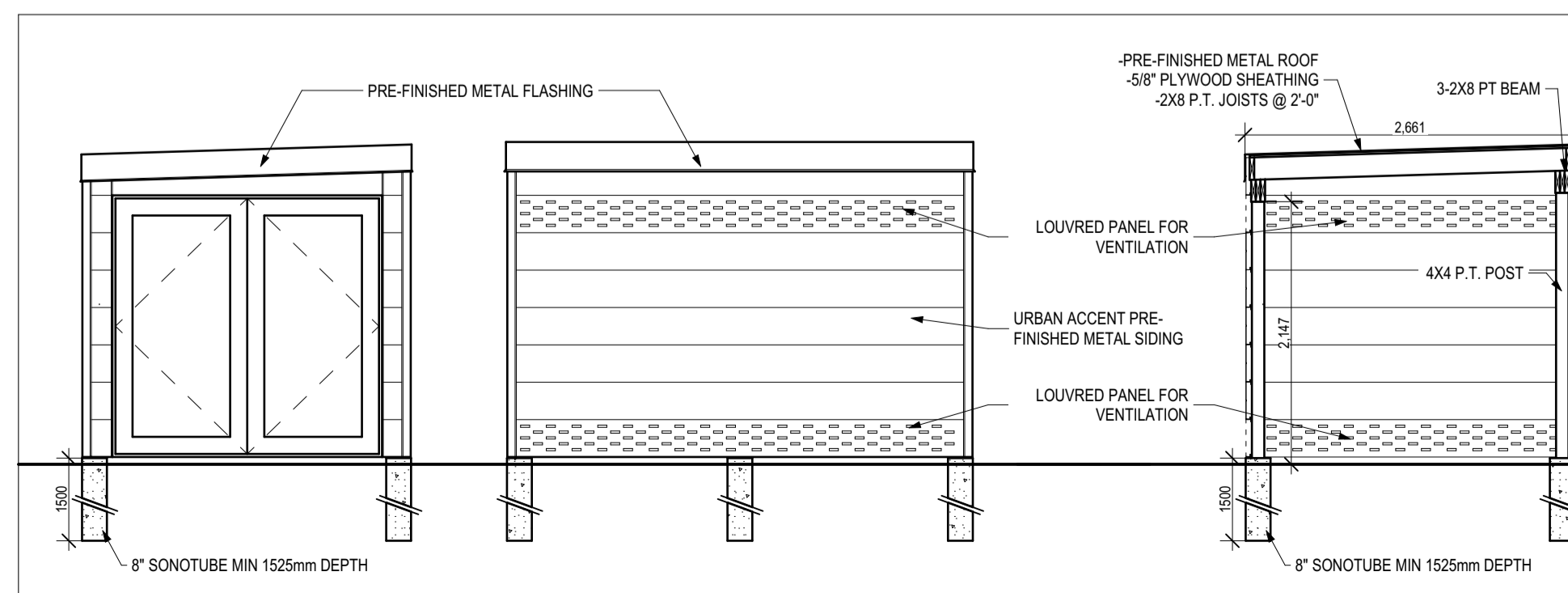

2 GARBAGE ENCLOSURE

SCALE: 1:50

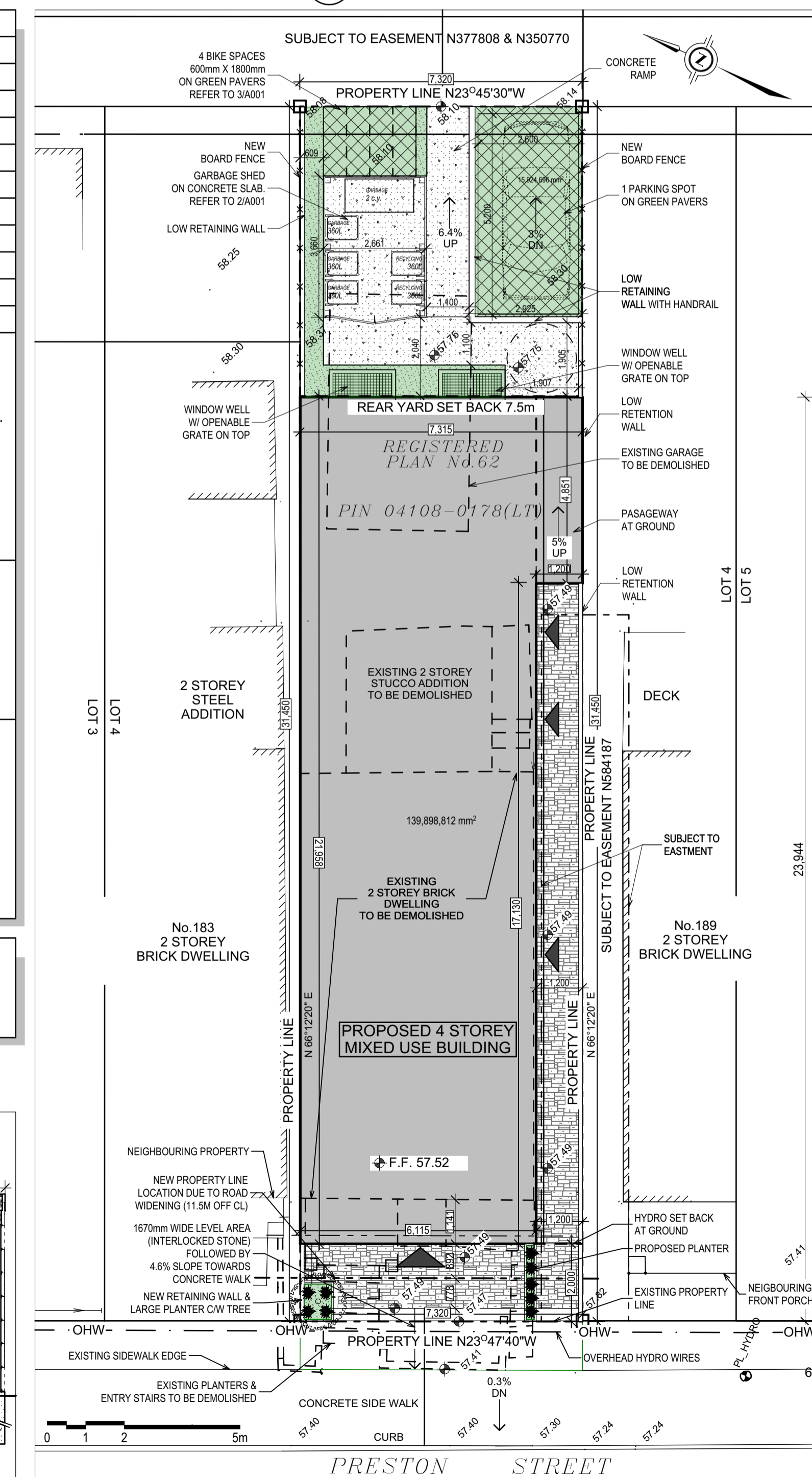

1 SITE PLAN

SCALE: 1:100

DRAWING LEGEND:

- BUILDING ENTRY
- GREEN PAVERS
- GRASS
- CONCRETE
- INTERLOCK STONE
- GRASS
- PLANTING

REVISIONS:

No.	DESCRIPTION	DATE
02	RE-ISSUED FOR SITE PLAN CONTROL	2020-01-10
01	ISSUED FOR SITE PLAN CONTROL	2019-12-18

DRAWINGS COPYRIGHT ROBERTSON MARTIN ARCHITECTS.
 DO NOT COPY. DO NOT SCALE DRAWINGS.
 ALL DIMENSIONS TO BE CHECKED AND VERIFIED ON SITE.

NORTH:

PROJECT:

MIXED-USE DEVELOPMENT

185-187 PRESTON ST. OTTAWA ONTARIO CANADA

DRAWING:

SITE PLAN AND LANDSCAPE PLAN

DESIGNED BY: MCV/LB APPROVED BY: SR

DRAWN BY: MCV/FM

DATE: 2020-01-10 SCALE: AS NOTED

RMA PROJECT NUMBER SHEET NUMBER:

20024 A002

STAMP:



CLIENT:

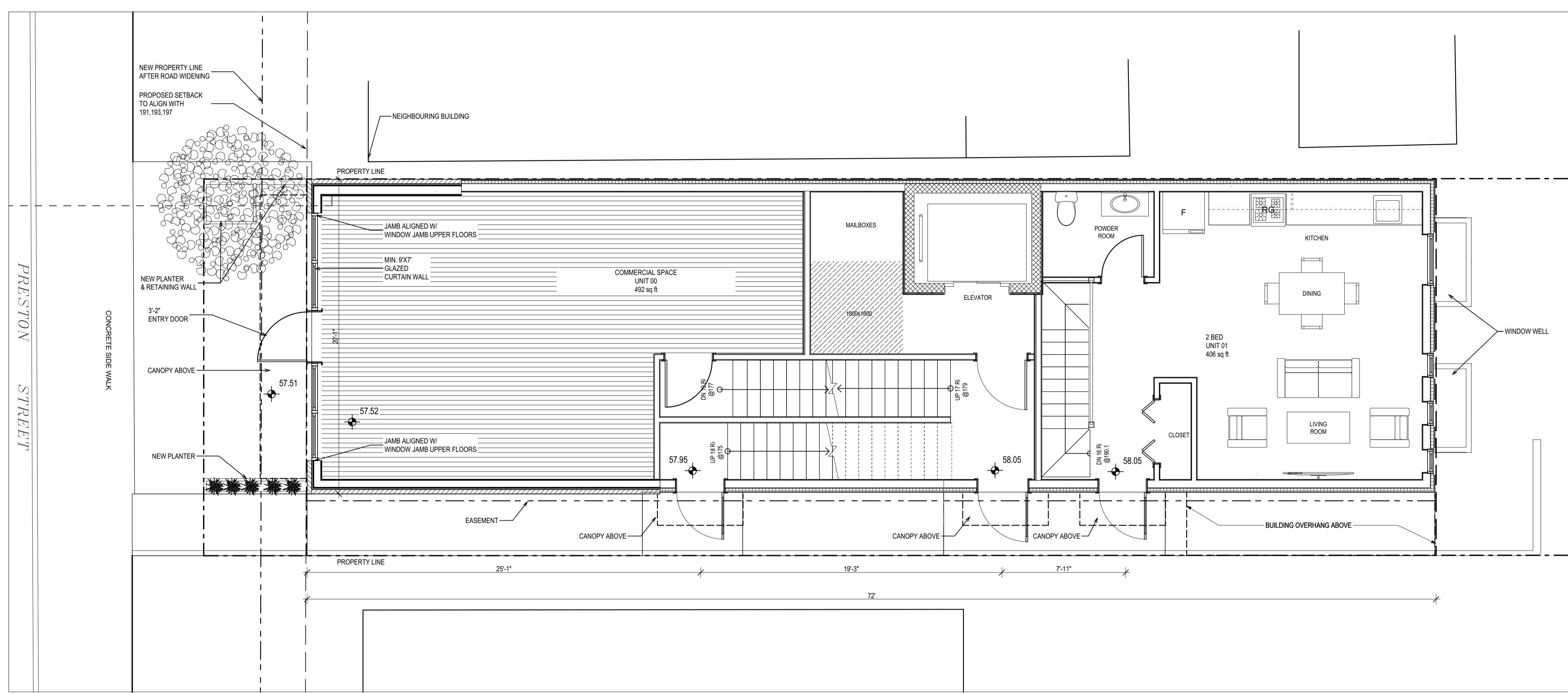

2 GROUND FLOOR PLAN
SCALE: 1/50

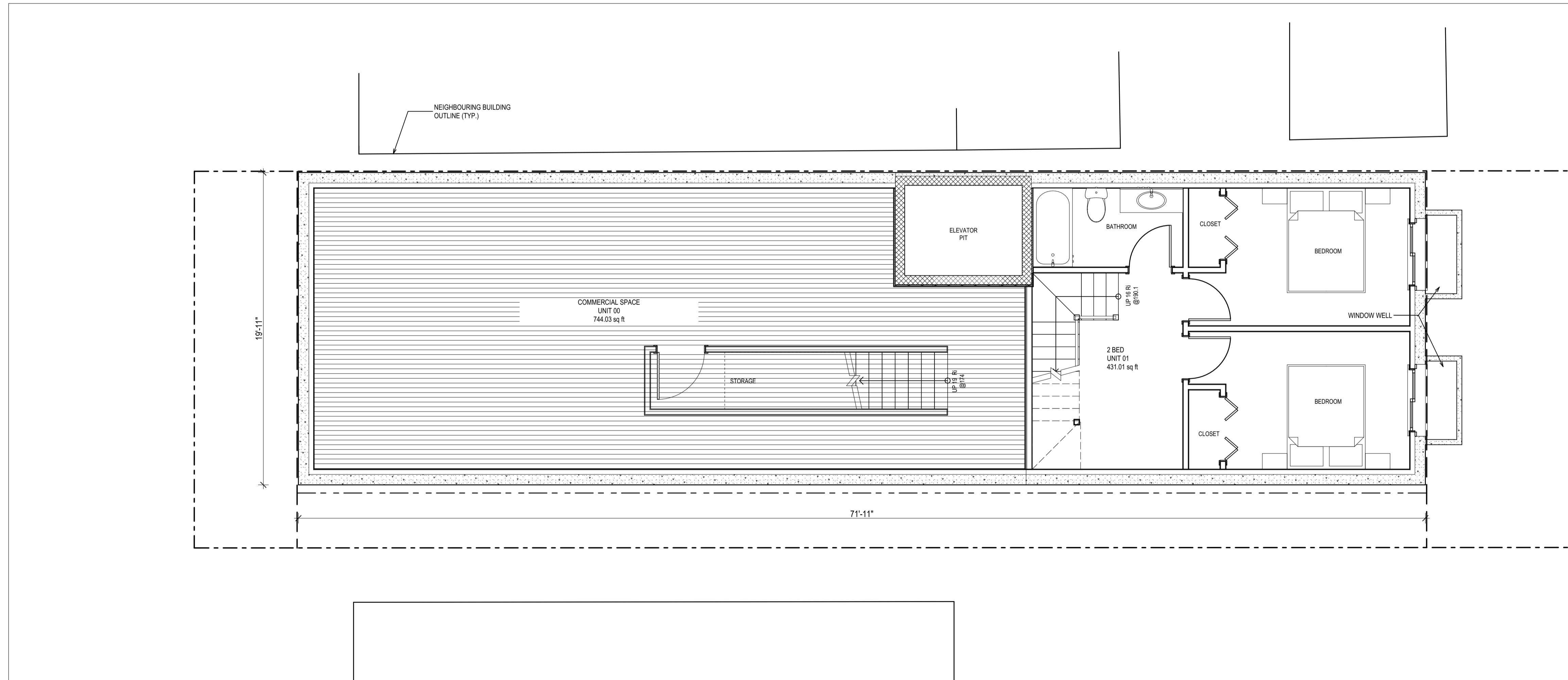

1 BASEMENT FLOOR PLAN
SCALE: 1/50

DRAWING LEGEND:

	COMMERCIAL SPACE
	PROPERTY LINE
	SET BACK
	EASEMENT

REVISIONS:

No.	DESCRIPTION	DATE
02	RE-ISSUED FOR SITE PLAN CONTROL	2020-01-10
01	ISSUED FOR SITE PLAN CONTROL	2019-12-18

DRAWINGS COPYRIGHT ROBERTSON MARTIN ARCHITECTS.
DO NOT COPY. DO NOT SCALE DRAWINGS.
ALL DIMENSIONS TO BE CHECKED AND VERIFIED ON SITE.

NORTH:



PROJECT:

MIXED-USE DEVELOPMENT

185-187 PRESTON ST. OTTAWA ONTARIO CANADA

DRAWING:

BASEMENT AND GROUND FLOOR PLAN

DESIGNED BY: MCV/LB APPROVED BY: SR

DRAWN BY: MCV/FM

DATE: 2020-01-10 SCALE: AS NOTED

RMA PROJECT NUMBER SHEET NUMBER:

20024 **A100**

STAMP:



CLIENT:

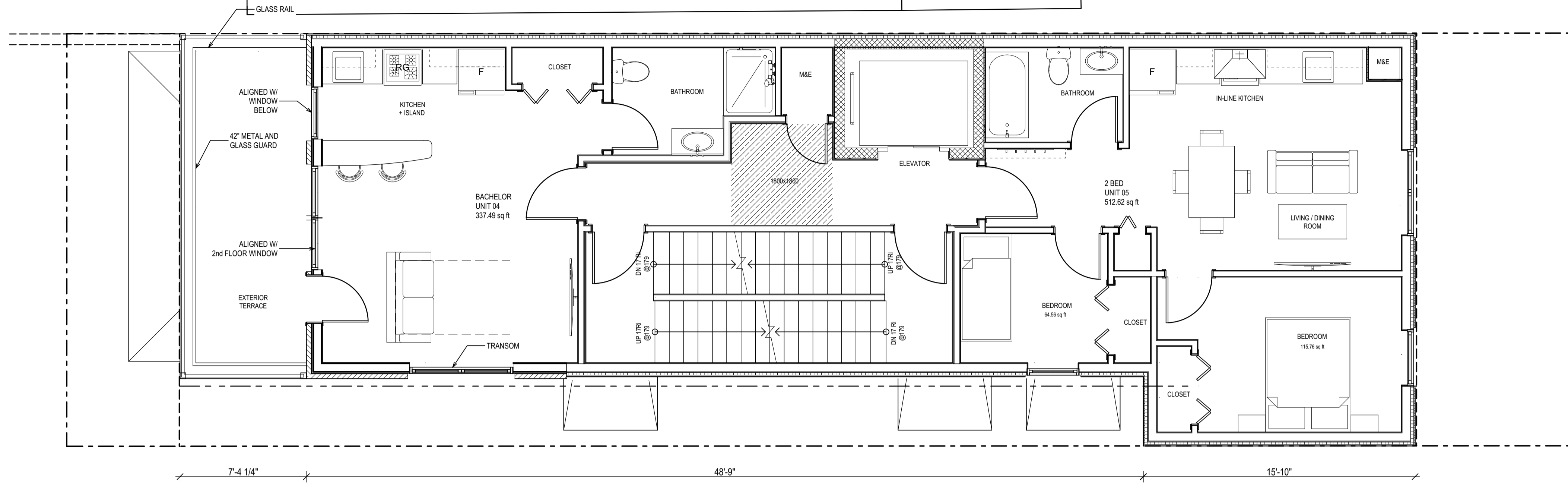

2 THIRD FLOOR PLAN
SCALE: 1/50

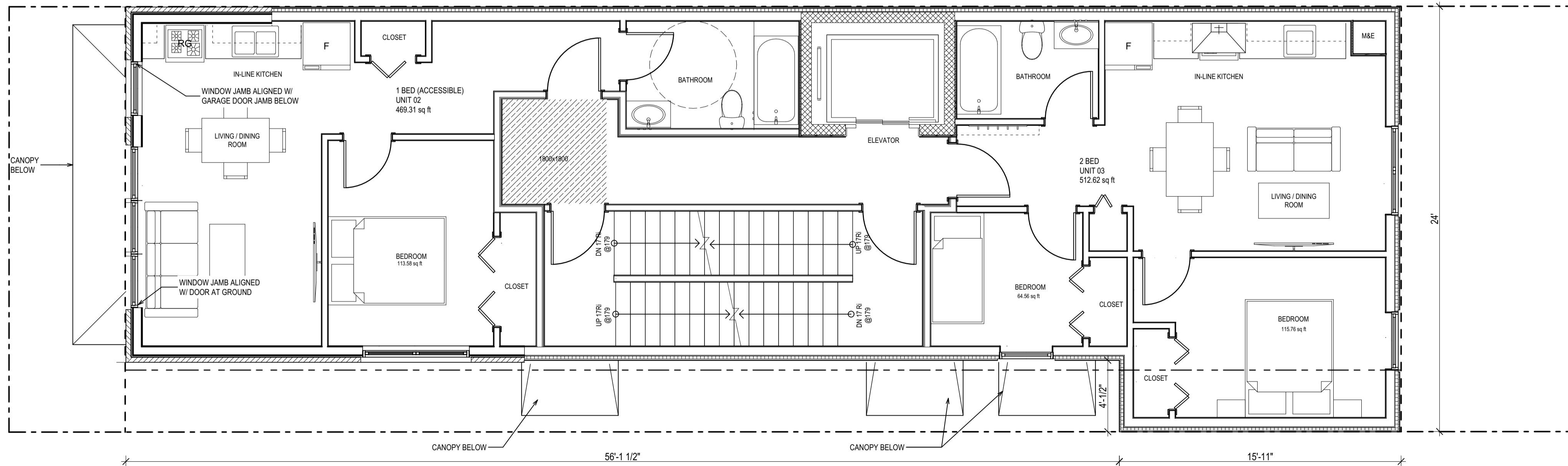

DRAWING LEGEND:
 - - - - - PROPERTY LINE
 - - - - - SET BACK
 - - - - - EASEMENT

REVISIONS:

No.	DESCRIPTION	DATE
02	RE-ISSUED FOR SITE PLAN CONTROL	2020-01-10
01	ISSUED FOR SITE PLAN CONTROL	2019-12-18

DRAWINGS COPYRIGHT ROBERTSON MARTIN ARCHITECTS.
 DO NOT COPY. DO NOT SCALE DRAWINGS.
 ALL DIMENSIONS TO BE CHECKED AND VERIFIED ON SITE.

NORTH:



PROJECT:

MIXED-USE DEVELOPMENT

185-187 PRESTON ST. OTTAWA ONTARIO CANADA

DRAWING:

SECOND AND THIRD FLOOR PLAN

DESIGNED BY: MCV/LB APPROVED BY: SR

DRAWN BY: MCV/FM

DATE: 2020-01-10 SCALE: AS NOTED

RMA PROJECT NUMBER SHEET NUMBER:

20024 A101

1 SECOND FLOOR PLAN
SCALE: 1/50

STAMP:



CLIENT:

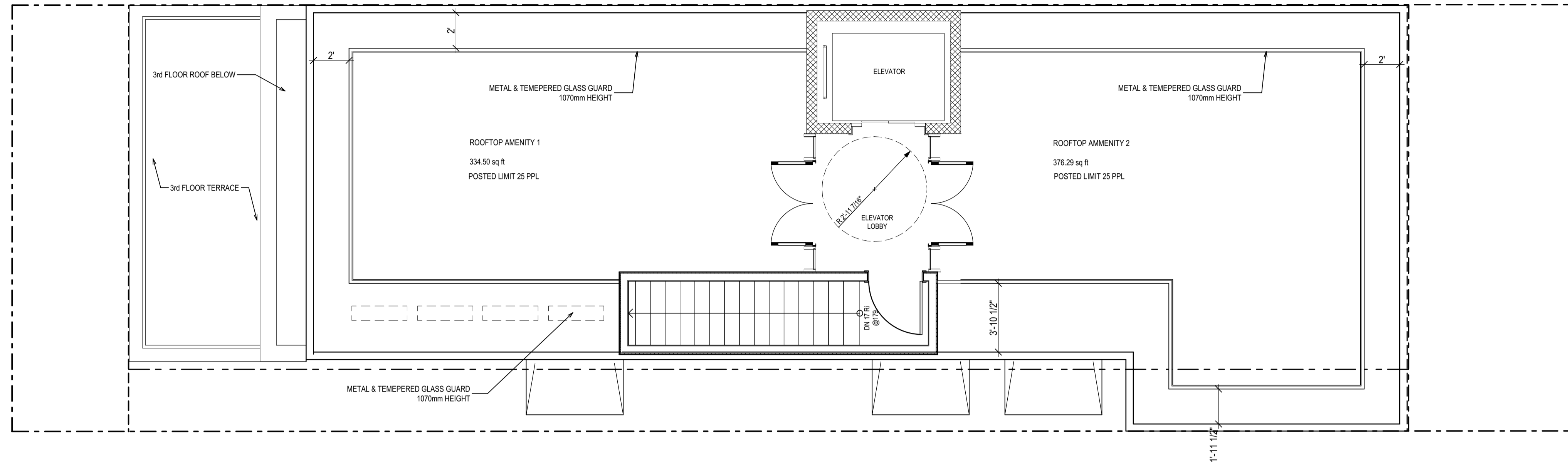

2 ROOF PLAN
SCALE: 1:50

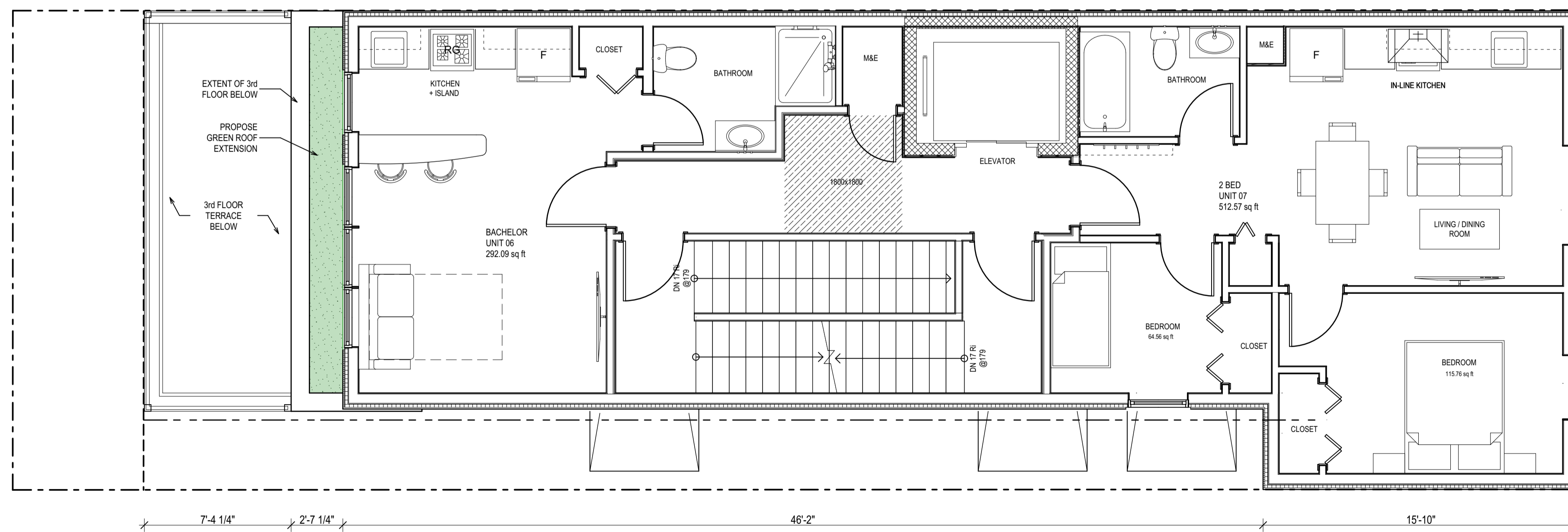

DRAWING LEGEND:

- PROPERTY LINE
- - - SET BACK
- - - EASEMENT

REVISIONS:

No.	DESCRIPTION	DATE
02	RE-ISSUED FOR SITE PLAN CONTROL	2020-01-10
01	ISSUED FOR SITE PLAN CONTROL	2019-12-18

DRAWINGS COPYRIGHT ROBERTSON MARTIN ARCHITECTS.
DO NOT COPY. DO NOT SCALE DRAWINGS.
ALL DIMENSIONS TO BE CHECKED AND VERIFIED ON SITE.

NORTH:



PROJECT:

MIXED-USE DEVELOPMENT

185-187 PRESTON ST. OTTAWA ONTARIO CANADA

DRAWING:

FOURTH FLOOR AND ROOF PLAN

DESIGNED BY: MCV/LB APPROVED BY: SR

DRAWN BY: MCV/FM

DATE: 2020-01-10 SCALE: AS NOTED

RMA PROJECT NUMBER SHEET NUMBER:

20024 A102

1 FOURTH FLOOR PLAN
SCALE: 1:50

STAMP:



CLIENT:

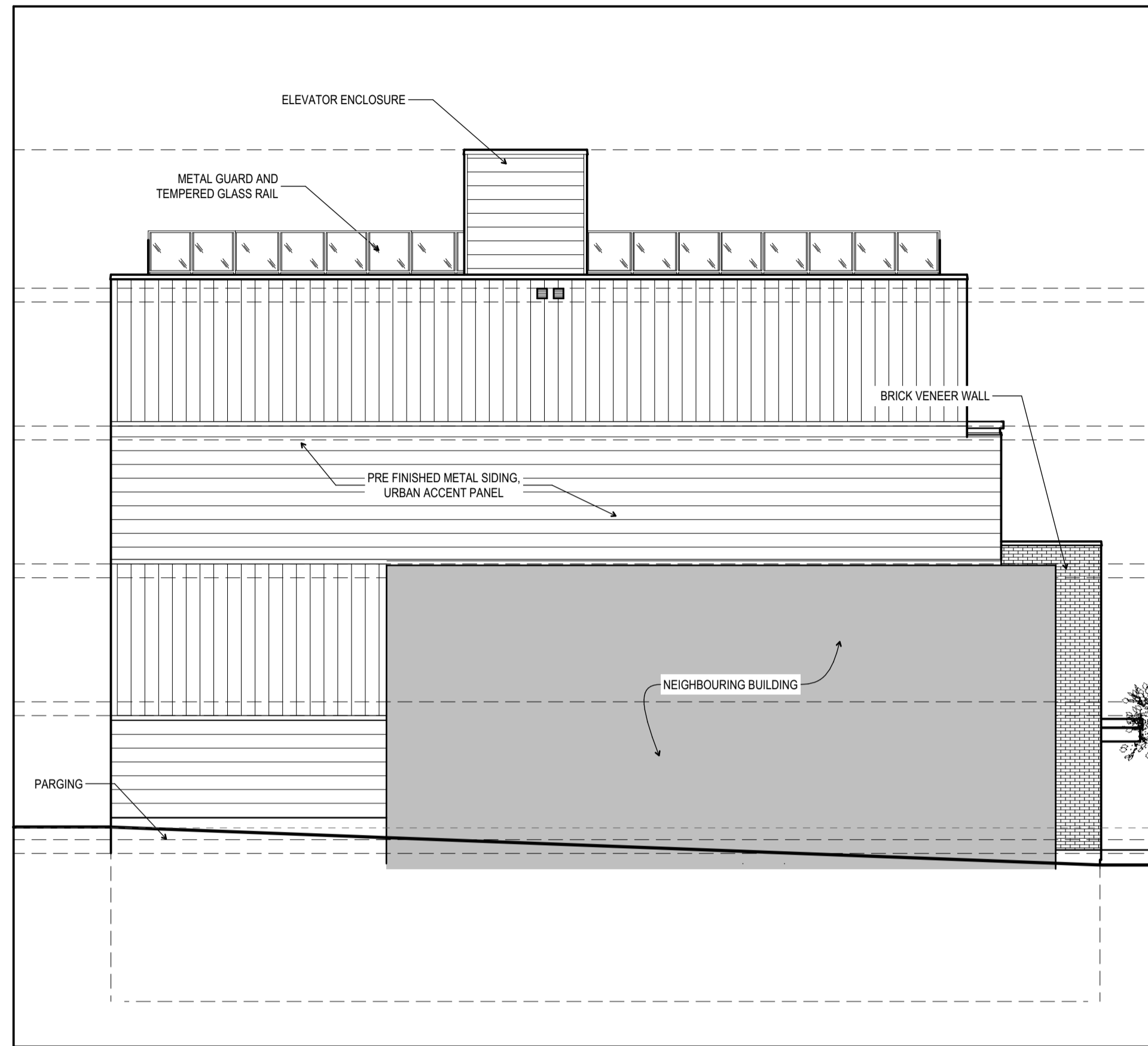

4 NORTH ELEVATION
SCALE: 1:100

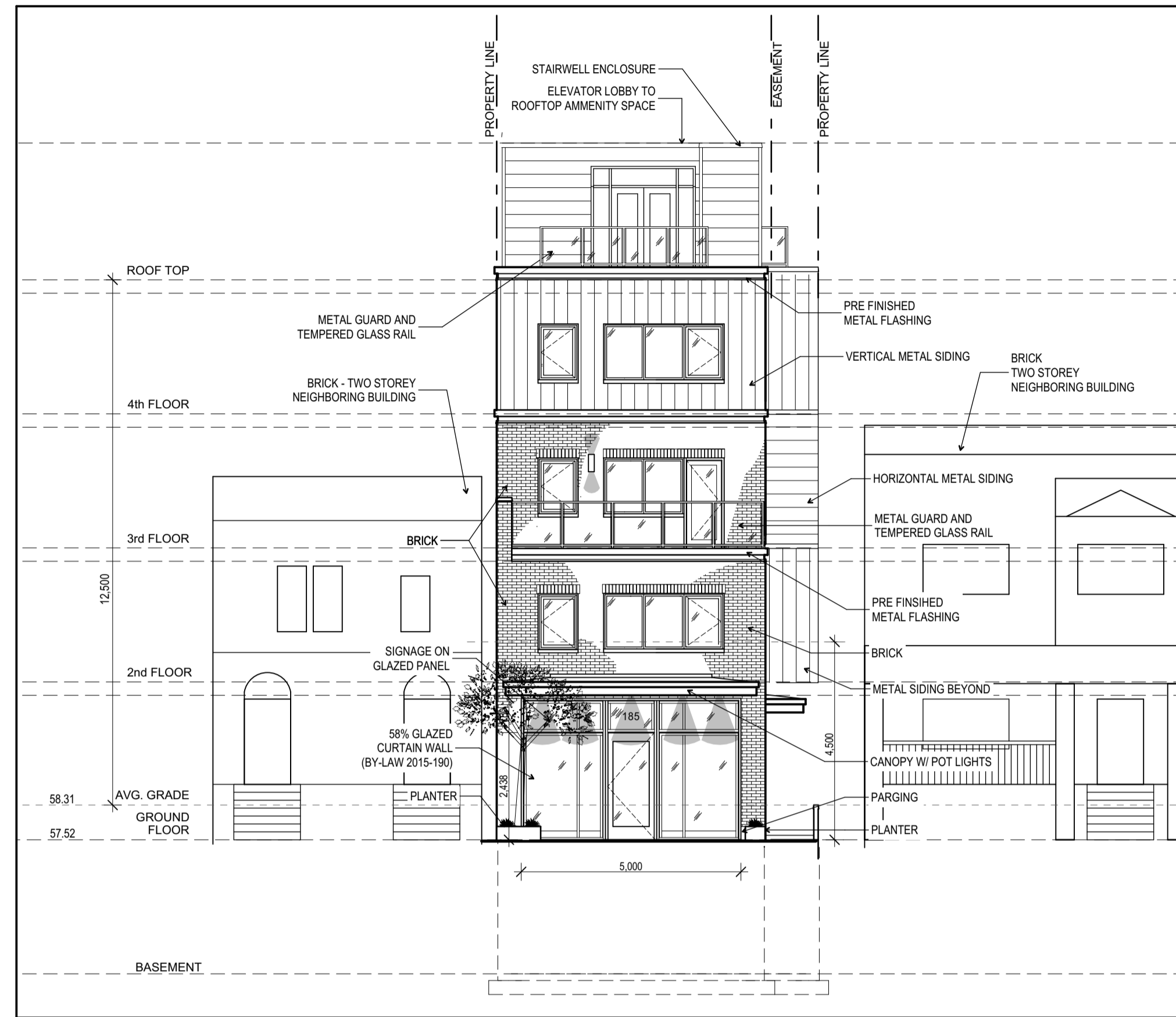

3 WEST ELEVATION
SCALE: 1:100

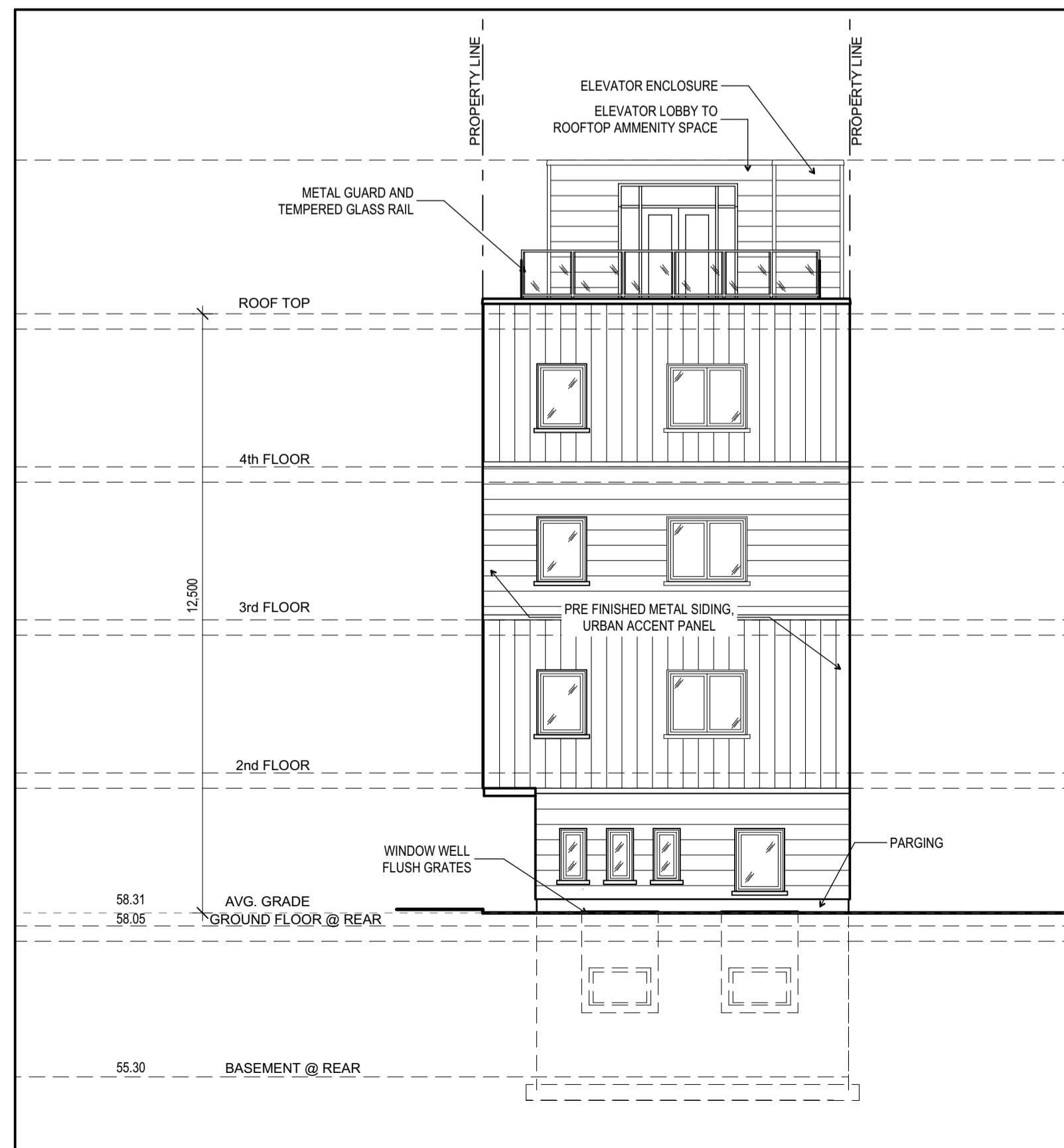

2 EAST ELEVATION
SCALE: 1:100

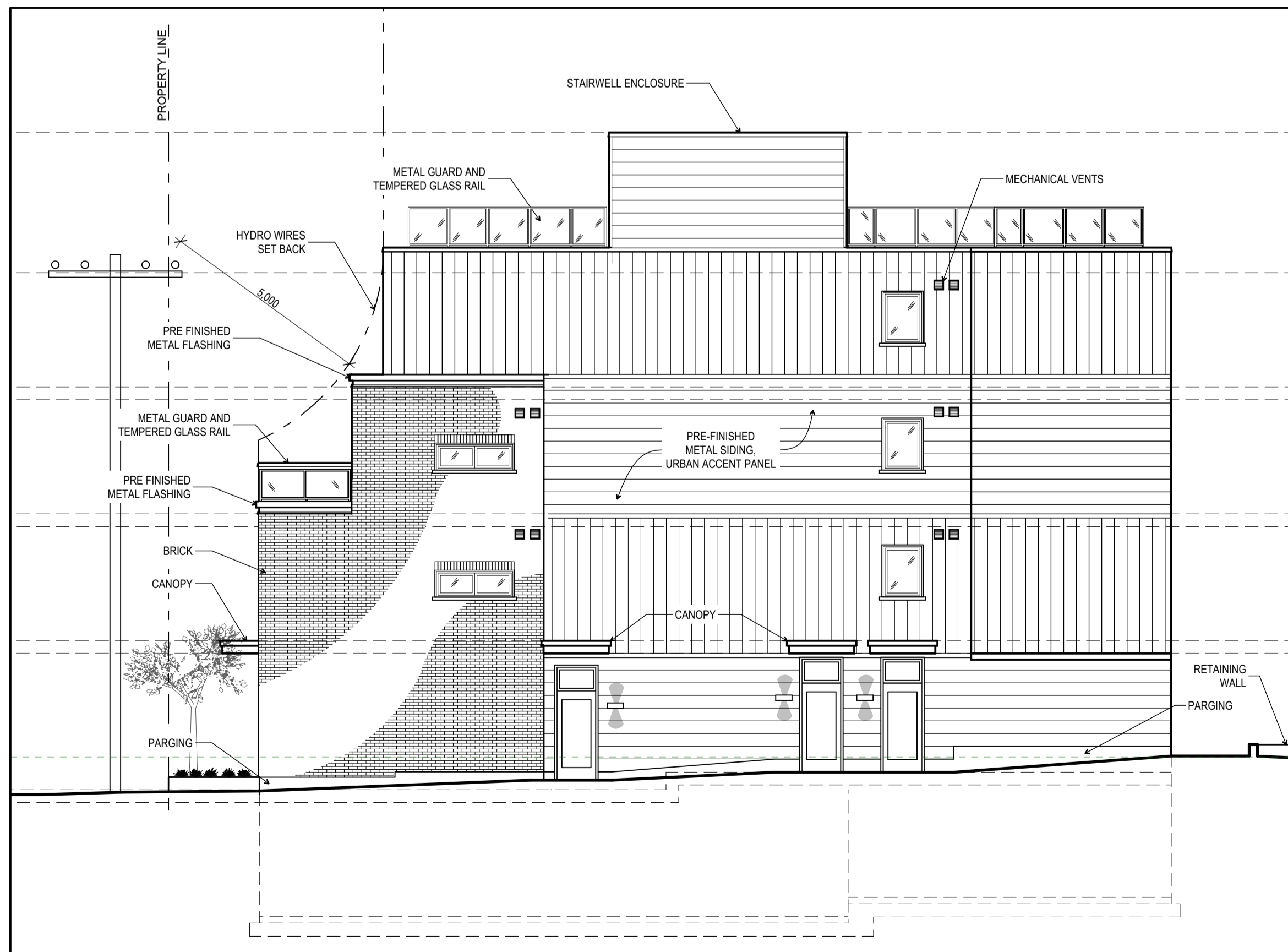

1 SOUTH ELEVATION
SCALE: 1:100

DRAWING LEGEND:

REVISIONS:

No.	DESCRIPTION	DATE
02	RE-ISSUED FOR SITE PLAN CONTROL	2020-01-10
01	ISSUED FOR SITE PLAN CONTROL	2019-12-18

DRAWINGS COPYRIGHT ROBERTSON MARTIN ARCHITECTS.
DO NOT COPY. DO NOT SCALE DRAWINGS.
ALL DIMENSIONS TO BE CHECKED AND VERIFIED ON SITE.

NORTH:

PROJECT:

MIXED-USE DEVELOPMENT

185-187 PRESTON ST. OTTAWA ONTARIO CANADA

DRAWING:

FACADE ELEVATIONS

DESIGNED BY: MCV/LB APPROVED BY: SR

DRAWN BY: MCV/FM

DATE: 2020-01-10 SCALE: AS NOTED

RMA PROJECT NUMBER SHEET NUMBER:

20024 A200