

Drawing Remains the Property of/Copyright Reserved by Gino J. Aiello Landscape Architect. Do Not Use or Reproduce Without Approval of Gino J. Aiello. NOT To Be Used For Construction Unless indicated by Revision: "FOR LANDSCAPE CONSTRUCTION". Contractor is Responsible for Verification of Site Locations of all Utilities. Report any Discrepancies Between Site and Drawing Immediately to Gino J. Aiello. Do NOT Proceed Until Clarified.

TURF AREAS TO BE SOD C/W 150MM DEPTH TOPSOIL ON APPROVED SUBGRADE | SOD TO BE #1 GRADE TURFGRASS NURSERY SOD per NSGA - Fine Fescue/Kentucky Bluegrass Sod | PLANTING MIX TO BE APPROVED BY LANDSCAPE ARCHITECT | PLANT MATERIAL TO MEET CNLA STANDARDS/BE APPROVED BY LANDSCAPE ARCHITECT PRIOR TO PLANTING | ALL MATERIALS & WORK TO BE MAINTAINED UNTIL FINAL ACCEPTANCE, (MOWING TURF, WEEDING BEDS, WATERING TURF & PLANTS) & INCLUDE 1 YEAR WARRANTY FROM DATE OF FINAL ACCEPTANCE | PROVIDE WATERING OF ALL PLANT MATERIAL AS REQUIRED FOR PROPER ESTABLISHMENT, UNTIL END OF WARRANTY PERIOD | REFER TO CIVIL ENGINEER'S DRAWING FOR ELEVATIONS / GRADING |

The Landscape Plan is to be read in conjunction with the grading, servicing, site and survey plan | Bare root material to be planted in season only | All plant material locations to be staked on site by the landscape contractor and checked by the landscape architect prior to planting | All trees to be preserved on or directly adjacent to the site will be protected | Plant material are to be installed a minimum of 3.0m away from any part of any hydro transformer, 3.0m corridor between a fire hydrant and the curb, a 2.5m radius beside or behind a fire hydrant, 2.0m from any servicing/utility line or structure |

-  Existing Tree to Remain
-  Existing Tree to be Removed
-  Proposed Deciduous Tree
-  Proposed Planting Bed
-  Proposed Peagravel On Filter Cloth

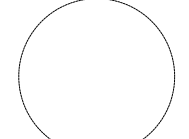
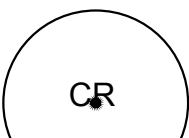
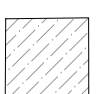
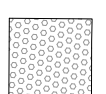
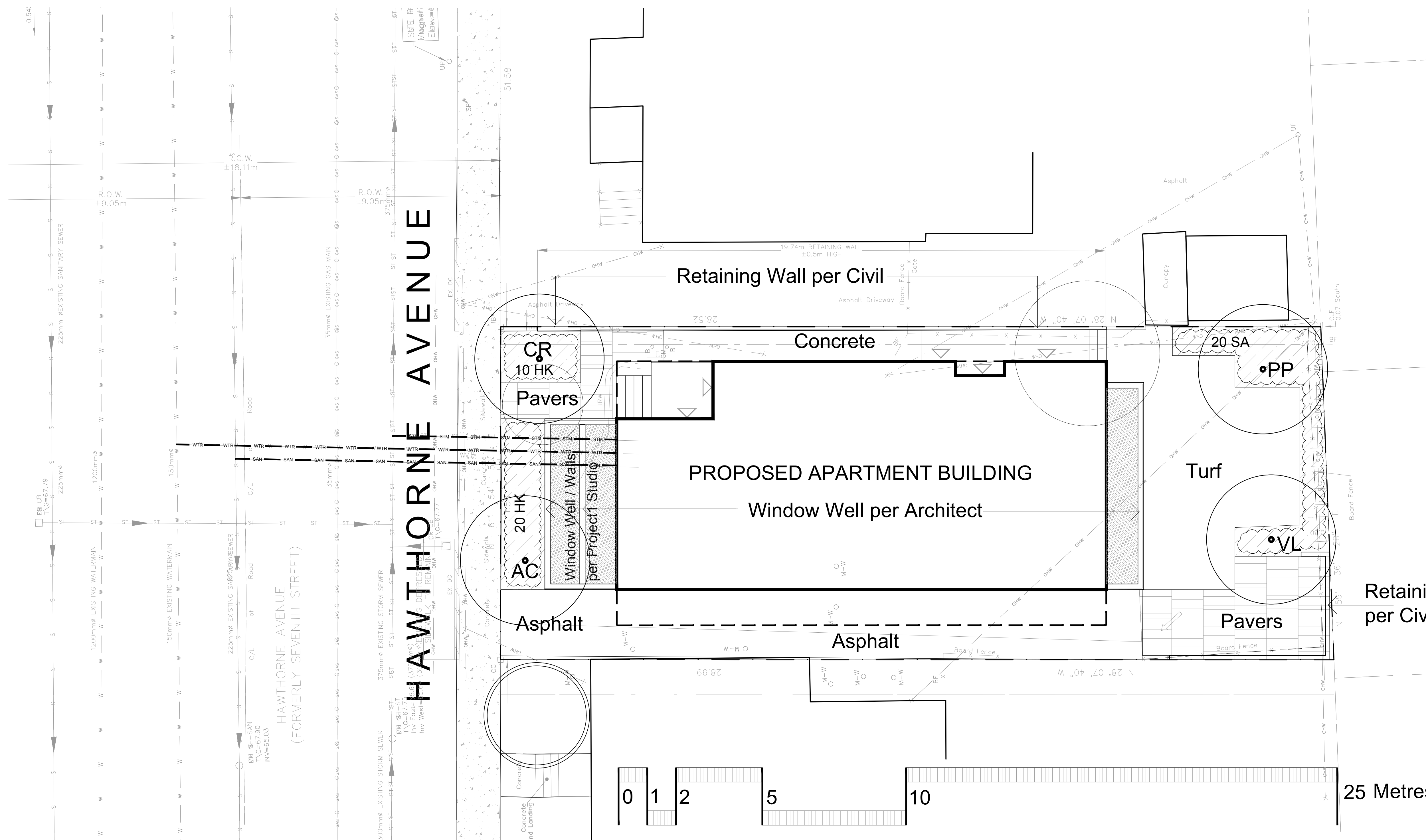

Plant List - Trees - 24 HAWTHORNE AVENUE					
Code	Qty.	Botanical Name	Common Name	Size	Condition
AC	1	Amelanchier canadensis	Tree Serviceberry	60mm cal	B + B specimen
CR	1	Cornus racemosa	Grey Dogwood	60mm cal	B + B specimen
PP	1	Prunus pensylvanica	Pin Cherry	60mm cal	B + B specimen
VL	1	Viburnum lentago	Nannyberry	60mm cal	B + B specimen

Plant List - Shrubs - 24 HAWTHORNE AVENUE					
Code	Qty.	Botanical Name	Common Name	Size	Condition
HK	30	Hypericum kalmianum	St. John's Wort	40cm Ht.	Pot
SA	20	Spiraea alba	Meadowsweet	60cm Ht.	Pot

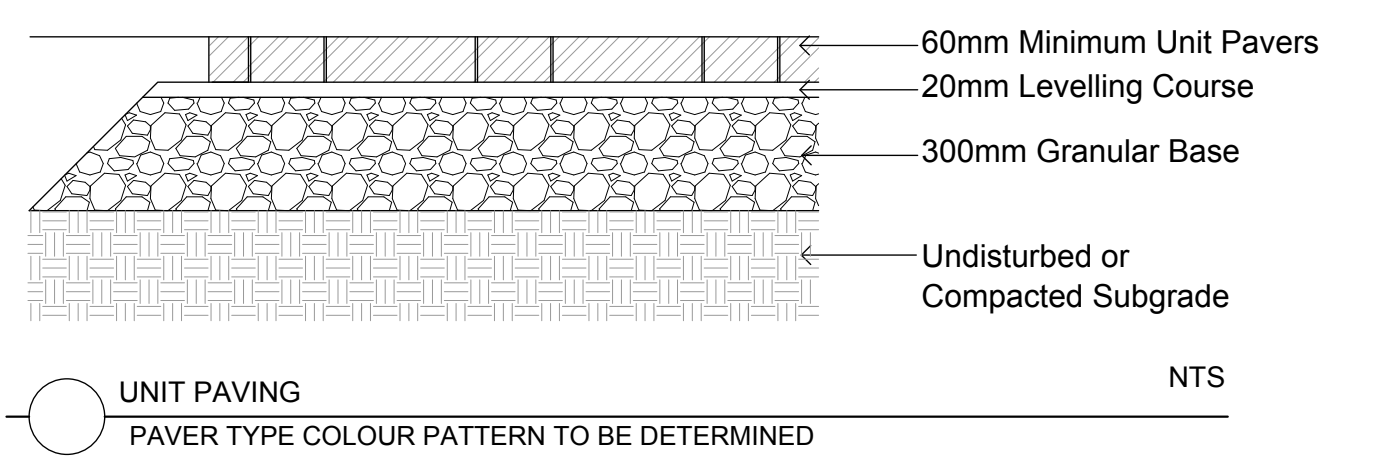
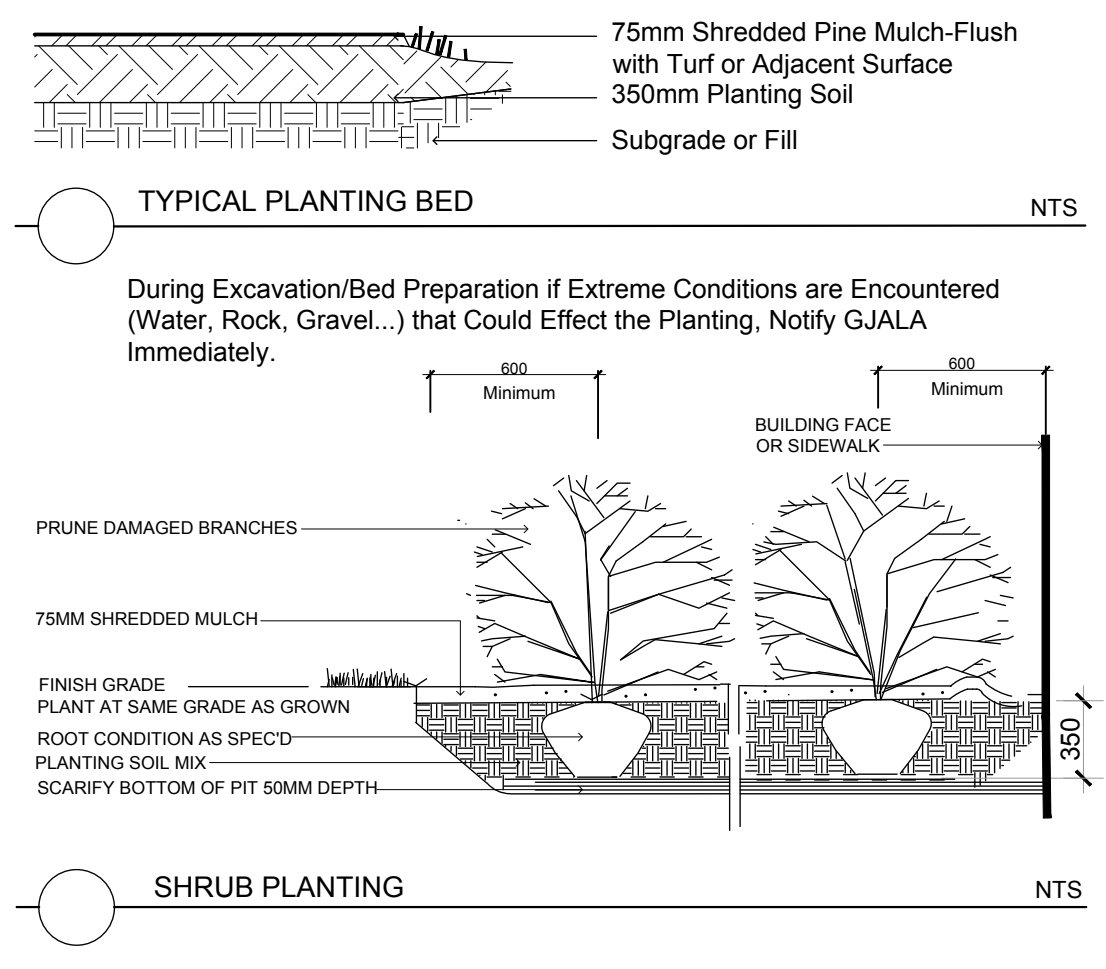
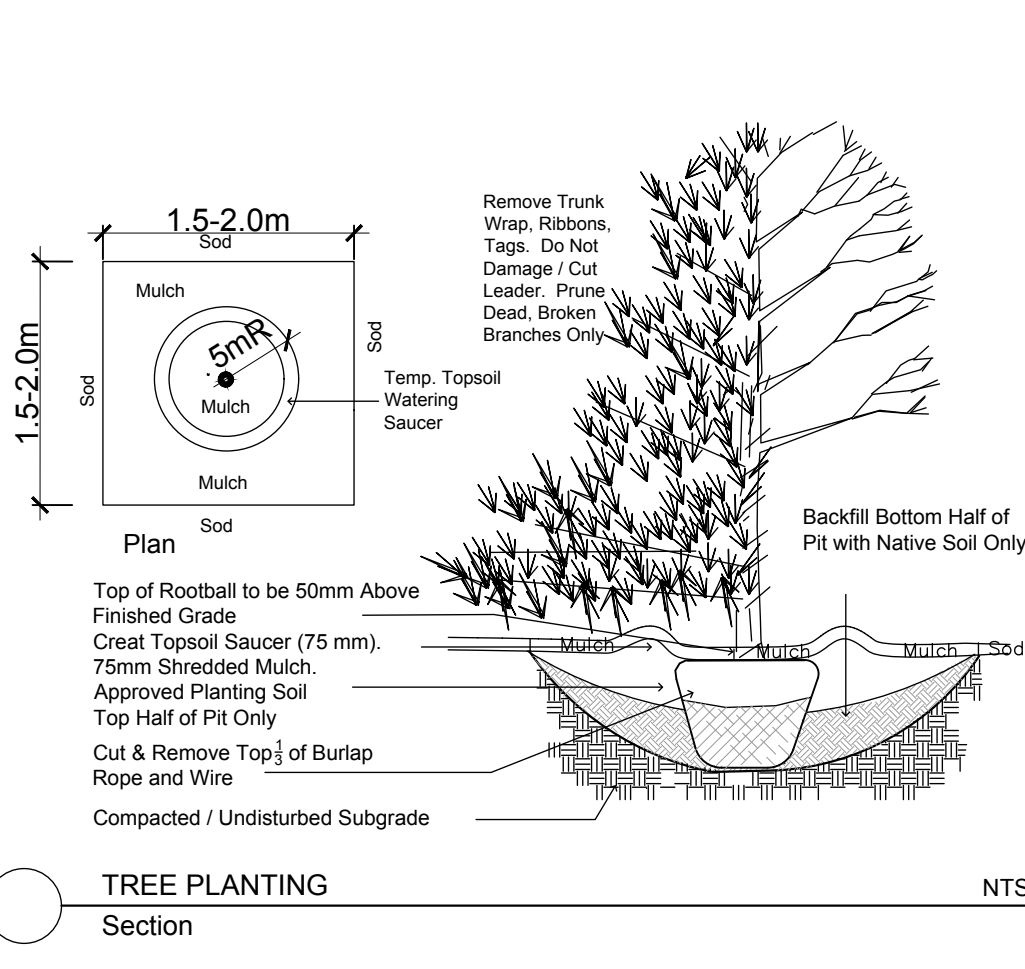

**GENERAL CONCRETE NOTES:**  
 ALL CONCRETE FINISHES TO BE APPROVED BY GJA LANDSCAPE ARCHITECT.  
 SAWCUT LAYOUT FOR ALL AREAS TO BE MARKED ON SITE IN RED CHALK, REVIEWED, ADJUSTED AND APPROVED BY GJA LANDSCAPE ARCHITECT-PRIOR TO ANY CUTTING.  
 EXPANSION JOINT LAYOUT FOR ALL AREAS TO BE LAID OUT ON SITE, REVIEWED, ADJUSTED AND APPROVED BY GJA LANDSCAPE ARCHITECT-PRIOR TO ANY CONCRETE POURING.

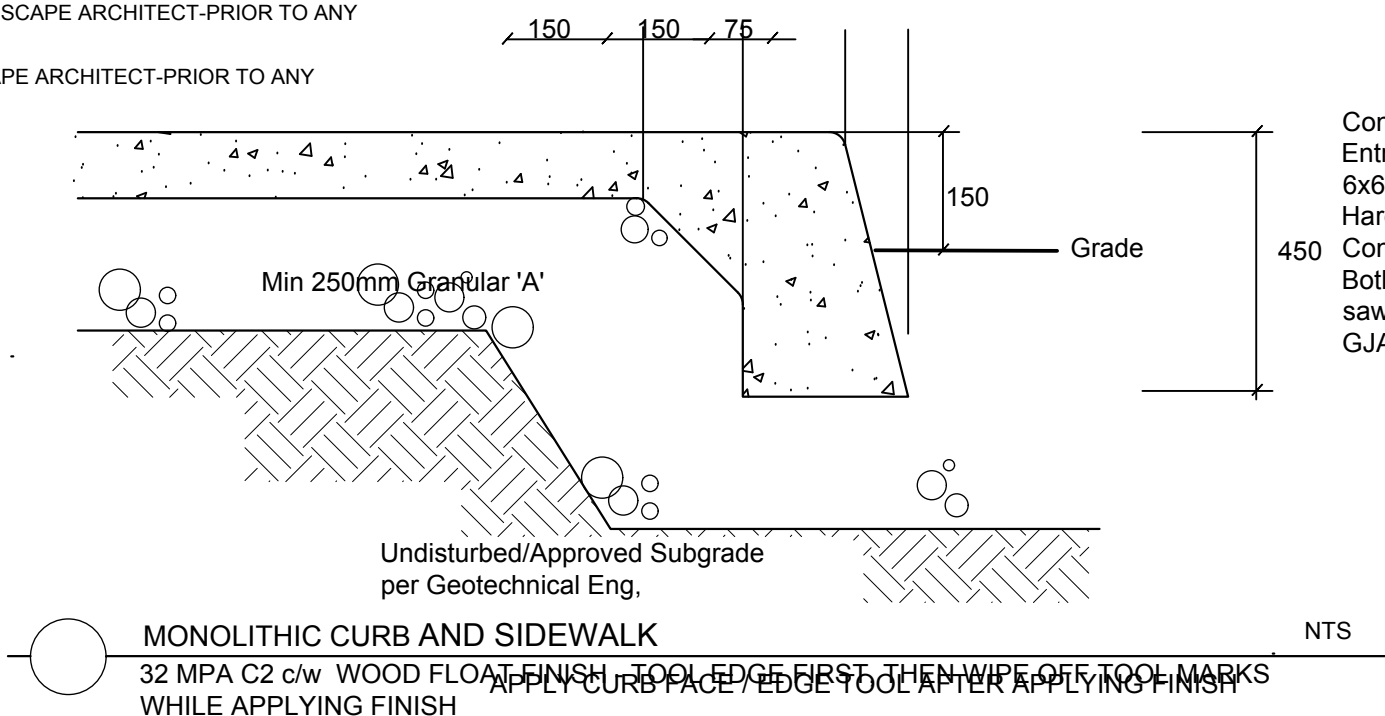
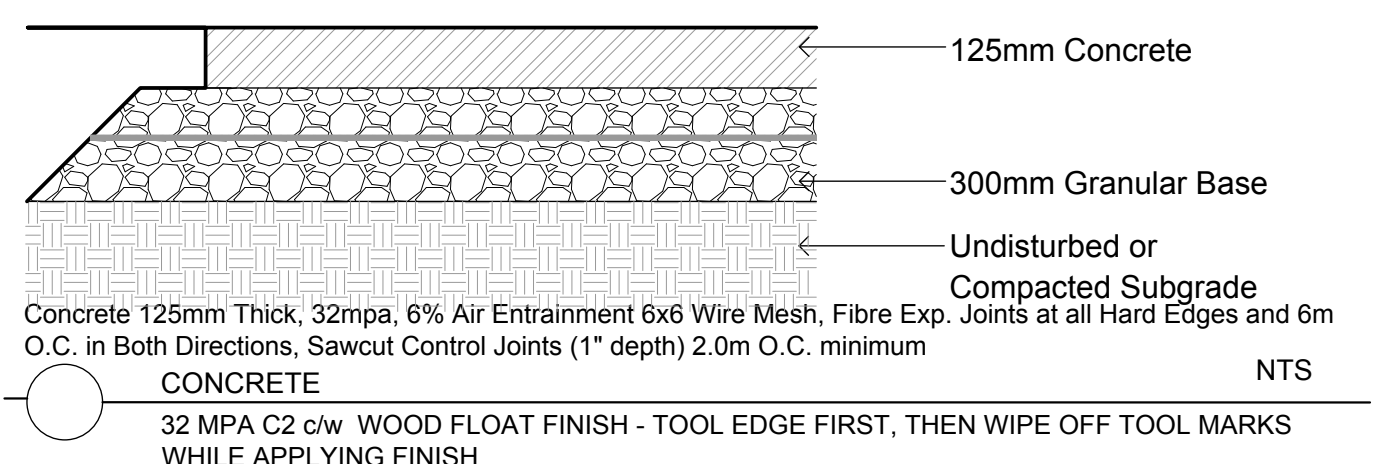

No.	Revision	Date
3	FOR SPC SUBMISSION 1	NOVEMBER 29 2018
2	FOR COORDINATION	OCTOBER 2018
1	FOR COORDINATION	MAY 2017

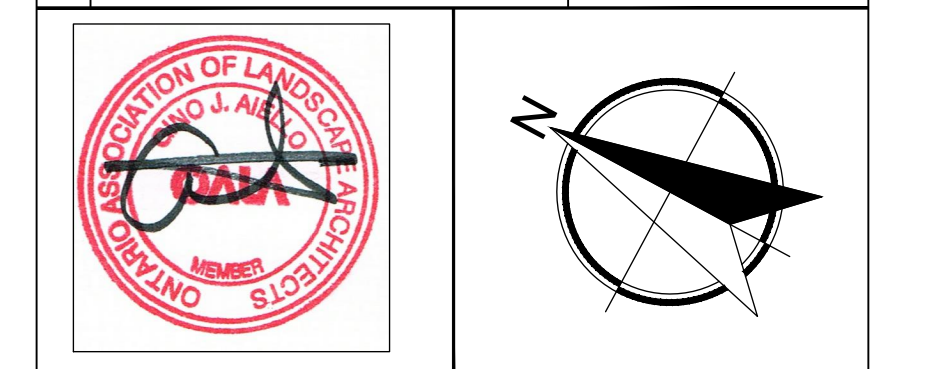

Property Owner **TC United Group**  
 800 Industrial Avenue Unit 9 Ottawa Ontario K1G 4B8

Gino J. Aiello landscape architect www.GJALA.com  
 Gino@GJALA.com (613) 852 1343  
 110 Didsbury Road Unit # 9 | Ottawa Ontario | K2T 0C2

Project **Proposed LowRise Apartment**  
 24 Hawthorne Avenue Ottawa Ontario

Drawing **Landscape Plan**  
 Date: MAY 2017 Sheet Number **L1**  
 Scale: 1:75  
 City of Ottawa  
 Dwg - #####

D07-##-##-###