



Site Servicing & Stormwater Management Report

2465070 Ontario Ltd
2375 St-Laurent Blvd., Ottawa, ON

Prepared for:

Graebek Construction Ltd.
160 Terence Matthews Crescent,
Kanata, ON
K2M 0B2

Attention: Mr. Evan Cory

LRL File No.: 130828

December 13, 2017



TABLE OF CONTENTS

1	INTRODUCTION	1
2	SITE DESCRIPTION	1
3	SCOPE OF WORK	1
4	WATER SUPPLY AND FIRE PROTECTION.....	2
4.1	Existing Water Supply Services.....	2
4.2	Water Supply Demand.....	2
4.3	Water supply servicing design	3
5	SANITARY DRAINAGE.....	3
5.1	Existing Sanitary Sewer Services.....	3
5.2	Sanitary Sewer Servicing Design	3
6	STORMWATER MANAGEMENT	4
6.1	Existing Stormwater Infrastructure	4
6.2	Stormwater management Concept	4
6.3	Design Criteria	5
6.3.1	Water Quality	5
6.3.2	Water Quantity.....	5
6.4	Method of Analysis	5
6.5	Allowable Release Rate.....	5
7	EROSION AND SEDIMENT CONTROL.....	6
8	CONCLUSIONS	6
9	LIMITATIONS AND USE OF REPORT	7

APPENDICES

Appendix A	Water Demand and Fire Flow Calculations
Appendix B	Sanitary Sewer Calculation Sheet
Appendix C	Stormwater Management Design Sheets
Appendix D	Hydrovex Vertical Vortex Flow Regulator Report
Appendix E	StormTech System Design Sheets
Appendix F	Stormceptor Report
Appendix G	Complete Set of Civil Plans
Appendix H	St-Laurent Blvd. As-Built Drawings
Appendix I	Boundary Conditions
Appendix J	Overland Ponding Volume Table



1 INTRODUCTION

LRL Associates Ltd. (LRL) has been retained by Graebeck Construction Ltd. to prepare a site servicing and stormwater management report in support of their site plan control application for a proposed site development. This report presents the proposed servicing plan for the proposed development in regards to water and sanitary services, as well as stormwater management.

This report has been prepared in consideration of the survey carried out by Annis, O'Sullivan, Vollebakk Ltd. dated August 11th, 2017. Should there be any discrepancies in the existing infrastructure and/or connections to existing services, which may relate to site servicing considerations, LRL should be advised in order to review the report recommendations. This report should be read in conjunction with the Civil plans prepared by LRL.

2 SITE DESCRIPTION

The subject property is located within the suburban boundary of the City of Ottawa; Ward 10 Gloucester-Southgate, within the Greens Creek Study Area. The proposed development will be a motorsports warehouse, located at 2375 St-Laurent Blvd. The total area of the property is approximately 0.659 ha.

The proposed development is located in an industrial area bounded by other light industrial properties and a parks and open space zone to the south. The property is currently a virgin site.

The proposed development will include a two-storey warehouse/garage with office space. The total footprint area of the proposed main building is 930m². There will also be a future building addition of 1000m² which will be built at a later date. The service calculations take into account both the proposed building and the future expansion.

3 SCOPE OF WORK

As per applicable guidelines, the scope of work includes the following:

Water services

- Calculate the expected water supply demand at average and peak conditions.
- Calculate the fire flow as per the Fire Underwriter Survey (FUS) method.
- Describe the proposed water distribution network and connection to the existing system.

Sanitary services

- Describe the existing sanitary sewers available to receive wastewater from the building.
- Calculate peak allowable release flow rate for the subject site.
- Calculate peak actual release flow rate and compare to allowable release.
- Describe the proposed sanitary sewer system.



Stormwater management

- Calculate the allowable stormwater release rate.
- Calculate the anticipated post development stormwater release rates.
- Demonstrate how the target quality and quantity objectives will be achieved.
- Describe the proposed storm sewer system.

4 WATER SUPPLY AND FIRE PROTECTION

4.1 Existing Water Supply Services

An existing 300mm dia. watermain extending along St-Laurent Blvd. is present north of the subject property. From this watermain, a 200mm dia. water service extends into the subject site and is capped off just inside the property line at the northeast corner. There are two existing fire hydrants near the northeast and northwest corners of the property on St-Laurent Blvd. The subject site is located in Pressure Zone 2C. Please refer to Appendix H for the St-Laurent Blvd. As-Built Drawings.

4.2 Water Supply Demand

As per MOE and City of Ottawa Design Guidelines, the average water demand for the subject light industrial development was calculated. A daily and hourly peak factor of **1.5** and **1.8**, respectively were used. The average daily water demand for the site is **0.27L/s**, maximum daily is **0.40L/s**, and maximum hourly is **0.72L/s**. Please refer to Appendix A for the water demand calculation sheet.

The fire flow demand was estimated in accordance with the Fire Underwriters Survey (FUS). This method is based on the floor area of the building to be protected, type and combustibility of the structural frame and the separation distances with adjoining buildings. The fire flow demand was calculated to be **150.0L/s**. Please refer to Appendix A for the fire flow calculation sheet.

The City of Ottawa has provided boundary conditions to LRL Associates for this project. Please refer to Appendix I for boundary conditions. Using the provided HGLs, minimum, maximum and maximum day + fire pressures were calculated at the St-Laurent Blvd. connection. Head losses were then calculated from the connection to the proposed building for the maximum daily demand, maximum hourly demand and maximum daily demand + fire flow. For each of these scenarios, the relevant pressures were determined. Adequate water supply/pressure is available and meets the City of Ottawa standards as per section 4.2.2 of the Ottawa Design Guidelines – Water distribution. For the maximum daily demand, a minimum and maximum pressure of **60.89** and **69.57** psi were calculated; these land within the 50 to 80 psi MOE range.



For the maximum hourly demand, a minimum and maximum pressure of **60.63** and **69.31** psi were calculated; these land within the 40 to 80 psi MOE range. For the maximum daily demand + fire flow, a pressure of **57.33** psi was calculated; this is above the minimum 20 psi MOE requirement. A pressure reducing valve is not required based on the above analysis. Please refer to Appendix A for pressure loss calculations.

Summary Table	
Average Water Demand Rate	23065 L/day
Factors	1.5(max daily) & 1.8(max hourly)
Average Day Demand (L/s)	0.27
Maximum Daily Demand (L/s)	0.40
Peak Hour Demand (L/s)	0.72
FUS Fire Flow Requirement (L/s)	150.0
Max Day+Fire Flow (L/s)	150.4

4.3 Water supply servicing design

The proposed building will be serviced by a new 50mm dia. HDPE “Gold Stripe” water service; to be installed 2.4m below grade. The proposed service will connect to the existing 200mm dia. service stubbed at the property line; located at the northeast corner of the site. One 200mm x 100mm reducer and one 100mm x 50mm reducer will be installed to allow for the proposed water service.

Fire flow protection is to be provided by the existing fire hydrants located near the northeast and northwest corners of the property on St-Laurent Blvd. The existing northwest hydrant is located 40m from the proposed building’s front entrance.

5 SANITARY DRAINAGE

5.1 Existing Sanitary Sewer Services

An existing 300mm dia. sanitary sewer extending along St-Laurent Blvd. is present north of the subject property. Please refer to Appendix H for the St-Laurent Blvd. As-Built Drawings.

5.2 Sanitary Sewer Servicing Design

The new building, including the future addition, will be serviced with a new 150mm dia. sanitary service, which will connect to the existing 300mm dia. sanitary sewer on St-Laurent Blvd. A new monitoring manhole (SAN MH1) is to be installed along the proposed 150mm service; near the property line. The new proposed 150mm PVC sanitary service will be installed at a minimum slope of 1.0%, as per the City of Ottawa Sewer Design Guidelines.



The parameters used to calculate the site's allowable sanitary flows are: Light Industrial average flow demand of 35,000 L/ha/day, an industrial peaking factor of 7.25 (as per Appendix 4-B of the Ottawa Sewer Design Guidelines) and an infiltration rate of 0.28 L/s/ha. Based on these parameters and the total site area of 0.659 ha, the total allowable sanitary flow was estimated to be **2.12 L/s**. Refer to Appendix B for the site's sanitary sewer design sheet.

As per Table 8.2.1.3.B of the Ontario Building Code, the site's anticipated sanitary flow is **3,700 L/day (0.04 L/s)**. The proposed building and future addition will have 2 water closets and 12 loading bays. Under the "Warehouse" item: 2 water closets x 950 L/day = 1900 L/day and 12 loading bays x 150 L/day = 1800 L/day; for a total of 3,700 L/day (0.04 L/s).

The site's anticipated sanitary flow is lower than its allowable flow. The proposed sanitary service has been sized to accommodate the peak allowable flow.

6 STORMWATER MANAGEMENT

6.1 Existing Stormwater Infrastructure

An existing 1200mm dia. storm sewer extending along St-Laurent Blvd. is present north of the subject property. Please refer to Appendix H for the St-Laurent Blvd. As-Built Drawings.

6.2 Stormwater management Concept

The information below should be read in conjunction with LRL drawings C401 and C701, as well as Appendix C (the stormwater management design sheets). The pervious and impervious runoff coefficients have been increased by 25% for the 100yr event; as per the Ottawa Sewer Design Guidelines.

The pre-development 5yr allowable release rate has been calculated using a C coefficient of 0.5 as per the City Pre-Application Consultation Memo, a calculated time of concentration of 36 minutes using the FAA/Rational Method, a calculated intensity of 47.2mm/hr as per City of Ottawa guidelines, and a total site area of 0.659ha. The allowable release rate was calculated to be **29.98L/s**.

The post-development conditions (100 year storm event) were designed using a restricted release flow of **43.22L/s** using Hydrovex Vertical Vortex Flow Regulator model 150VHV-2 to be installed in proposed CBMH5.

The 100year storm runoff from proposed catchment areas CA-01 to CA-06 will be controlled at proposed CBMH5. Runoff above the 100year will back out of all proposed CBMHs and pond around each drainage structure until it flows overland, making its way to St-Laurent Blvd. through the spill out point located at the northeast side of the entrance at the property line. Stormwater will not back up through the system and make its way out of CB1 (located at the bottom of the loading dock area) due to a proposed Armttec flap gate to be installed on the CB's

south inlet. Stormwater from the 5yr storm event will always remain underground; it will never back up/out of the drainage structures and pond overland.

The 100yr storage required for this site is **219.82m³**. The 100yr storage provided is **222.41m³**. This is a combination of the overland ponding storage of 62.78m³ (refer to Appendix J for the Overland Ponding Volume Table), StormTech chambers storage of 133.00m³ (refer to Appendix E for StormTech System Design Sheets) and the underground pipes and drainage structures storage of 26.63m³. This storage capacity will be possible using a Hydrovex Vertical Vortex Flow Regulator model 150VHV-2 to be installed in proposed CBMH5 at an allowable release rate of **43.22L/s**. Refer to Appendix D for Hydrovex Vertical Vortex Flow Regulator Report.

6.3 Design Criteria

Stormwater quantity and quality control measures are taken into account for this site to reduce post development stormwater runoff to allowable levels.

6.3.1 Water Quality

The enhanced 80% TSS removals requirement will be met through the proposed Stormceptor STC 300 oil/grit separator which will provide adequate water quality treatment. Please refer to Appendix F for the Stormceptor Report. An isolator row has been incorporated into the StormTech system as well providing additional on-site quality treatment.

6.3.2 Water Quantity

All storm events up to and including the 100 year event will be controlled to the 5 year pre-development level. The site's major overland flow route has been designed to ensure that storm events beyond the 100 year design storm can be safely conveyed overland towards the St-Laurent Blvd. right of way. The minor system (the on-site storm sewer system) is sized to convey the 5 year storm event flows from the site to the municipal storm sewer on St-Laurent Blvd.

6.4 Method of Analysis

The Rational Method was used to calculate the runoff from the development. The Intensity-Duration-Frequency (IDF) curve formulas of the MacDonald Cartier International Airport, City of Ottawa, were used to calculate the peak storm flows.

6.5 Allowable Release Rate

The pre-development 5yr allowable release rate has been calculated using a C coefficient of 0.5 as per the City Pre-Application Consultation Memo, a calculated time of concentration of 36



minutes using the FAA/Rational Method, a calculated intensity of 47.2mm/hr as per City of Ottawa guidelines, and a total site area of 0.659ha.

7 EROSION AND SEDIMENT CONTROL

During construction, erosion and sediment controls will be provided primarily via a sediment control fence to be erected along the perimeter of the site where runoff has the potential of leaving the site. Inlet sediment control devices are also to be provided in any catchbasin and/or manhole in and around the site that may be impacted by the site construction. Construction and maintenance requirements for erosion and sediment controls are to comply with Ontario Provincial Standard Specification (OPSS) # 577. Refer to LRL drawing C.101 for erosion and sediment control details.

8 CONCLUSIONS

In accordance with the report objectives, the analyses of the proposed development can be summarized as follows:

Water Service

- The anticipated maximum domestic water demand of the site is 0.72L/s.
- The maximum required fire flow was calculated at 150.0L/s using the FUS method.
- There are two existing fire hydrants located near the northeast and northwest corners of the property on St-Laurent Blvd. within a 90m radius. The existing northwest hydrant is located 40m from the proposed building's front entrance.
- The new development will be serviced with by a new 150mm dia. water service connected to the existing 200mm dia. service stubbed at the property line; located at the northeast corner of the site.

Sanitary Service

- The total allowable sanitary flow was estimated to be 2.12 L/s.
- The site's anticipated sanitary flow is 0.04 L/s.
- The proposed building will be serviced by a new 150mm sanitary service which will be connected to the existing 300mm dia. sanitary sewer on St-Laurent Blvd.
- A new monitoring manhole will be installed on the proposed 150mm sanitary service.

Stormwater Management

- The proposed storm system's 100yr post-development release rate of 43.22 L/s will meet the 5yr pre-development allowable release rate of 43.22 L/s.
- Stormwater quantity control objectives will be met through on-site stormwater storage.



- Stormwater quality control objectives will be met on-site through the use of a Stormceptor STC 300 oil/grit separator. An isolator row has been incorporated into the StormTech system as well providing additional on-site quality treatment.

9 LIMITATIONS AND USE OF REPORT

The report conclusions are applicable only to the project described in the report. Any changes require a review by LRL Associates Ltd. to insure compatibility with the recommendations contained in this report. We trust the information presented in this report meets City of Ottawa requirements. Please do not hesitate to contact us should you have any questions or concerns.

Prepared by:

LRL Associates Ltd.



Guillaume Courtois, C.E.T.
Civil Engineering Technologist



Jean-Claude Lalonde, P.Eng
Senior Engineer



APPENDIX A

Water Demand and Fire Flow Calculations

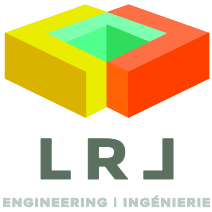

Water Service Calculations

LRL File No. : 170721
Project : 2465070 Ontario Ltd
Date : December 13, 2017
Designed by : Guillaume Courtois

Water Demand

Total site area: **0.659** ha

$Q_{average} =$ **35** $m^3 / ha \cdot day$ (As per MOE guidelines)

$Q_{average} = 23.065 m^3 / day$

$Q_{average} = 23065 L / day$

$Q_{average} = 0.27 L / s$

Maximum daily peak factor: 1.5

Maximum daily demand = 34598 L / day

= 0.40 L / s

Maximum hour peak factor: 1.8

Maximum hour demand = 62276 L / day

= 0.72 L / s

Water Service Pipe Sizing

$$Q = VA$$

Where: V = velocity

A = area of watermain pipe

Q = water supply flow rate

By deriving the above formula, we can obtain the diameter of the pipe:

Minimum pipe diameter:

$$d = (4Q/\pi V)^{1/2}$$

$$d = 0.023 \text{ m}$$

$$d = 23 \text{ mm}$$

Proposed pipe diameter: **50** mm (I.D. = 41mm)



Fire Flow Calculations

LRL File No. : 170721
Project : 2465070 Ontario Ltd
Date : December 13, 2017
Method : Fire Underwriters Survey (FUS)
Designed by : Guillaume Courtois

Step	Task	Term	Options	Multiplier	Choose:	Value	unit	Fire Flow	
Structural Framing Material									
1	Choose frame used for building	Coefficient C related to the type of construction	Wood Frame	1.5	Non-combustible construction	0.8			
			Ordinary Construction	1.0					
			Non-combustible construction	0.8					
			Fire resistive construction <2 hrs	0.7					
			Fire resistive construction >2 hrs	0.6					
Floor Space Area									
2	Choose type of housing	Type of housing	Single family dwelling	0	Building - no. of units per floor	1	unit(s)		
			Townhouse - no. of units	0					
			Building - no. of units per floor	1					
3	Enter area of a unit	Enter floor space area of one unit (excluding basement)		1	1930.0		sq.m.		
4	Obtain fire flow before reductions	Required fire flow	Fire Flow = 220 x C x Area^{0.5}					L/min	8,000
								L/s	133.3
Reductions or surcharge due to factors affecting burning									
5	Choose combustibility of contents	Occupancy hazard reduction or surcharge	Non-combustible	-0.25	Combustible	0			
			Limited combustible	-0.15					
			Combustible	0					
			Free burning	0.15					
			Rapid burning	0.25					
						L/min	8,000		
						L/s	133.3		
6	Choose reduction for sprinklers	Sprinkler reduction	Sprinklers (NFPA13)	-0.30	False	0			
			Water supply is standard for both the system and fire department hose lines	-0.10	False	0	L/min	8,000	
			Fully supervised system	-0.10	False	0	L/s	133.3	
7	Choose separation	Exposure distance between units	North side	Over 45m	0				
			East side	10.1 to 20m	0.15				
			South side	Over 45m	0		L/min	9,000	
			West side	Over 45m	0	0.15	L/s	150.0	
Net required fire flow									
8	Obtain fire flow, duration, and volume	Minimum required fire flow rate (rounded to nearest 1000)					L/min	9,000	
		Minimum required fire flow rate					L/s	150.0	
		Required duration of fire flow					hr	2	

Note: The above calculations take into account both the current proposed building of 930m² and the future proposed building of 1000m².



Pipe Pressure Losses Calculations

LRL File No. : 170721
Project : 2465070 Ontario Ltd
Date : December 13, 2017
Designed : Guillaume Courtois

Piezometric Head Equation (Derived from Bernoulli's Equation)

$$h = \frac{p}{\gamma} + z$$

Where:

h = HGL (m)

p = Pressure (Pa)

γ = Specific weight (N/m³) =

9810

z = Elevation of centreline of pipe (m) =

80.91

Water Pressure at St-Laurent Blvd. Connection			
HGL (m)		Pressure	
		kPa	psi
Minimum =	124.5	427.62	62.02
Maximum =	130.6	487.46	70.70
Max. Day + Fire =	124	422.71	61.31

Hazen Williams Equation

$$h_f = \frac{10.67 \times Q^{1.85} \times L}{C^{1.85} \times d^{4.87}}$$

Where:

h_f = Head loss over the length of pipe (m)

Q = Volumetric flow rate (m³/s)

L = Length of pipe (m)

C = Pipe roughness coefficient

d = Pipe diameter (m)

Scenario 1: maximum daily demand

Q (L/s)	0.40	
C	150	
L (m.)	31.5	
I.D. (mm)	41	
V (m/s)	0.30	
h_f (m)	0.09	
Head Loss (psi)	0.13	
Min. Pressure (psi)	61.89	
Max. Pressure (psi)	70.57	
Service Obv. @ Street Connection (m)	81.10	
Service Obv. @ Building Connection (m)	81.80	
Pressure Adjustment (psi)	-1.00	(due to service elevation difference from street to building)
Adjusted Min. Pressure (psi)	60.89	(must not be less than 50psi)
Adjusted Max. Pressure (psi)	69.57	(must not be more than 80psi)

Scenario 2: maximum hourly demand

Q (L/s)	0.72	
C	150	
L (m.)	31.5	
I.D. (mm)	41	
V (m/s)	0.55	
h_f (m)	0.28	
Head Loss (psi)	0.39	
Min. Pressure (psi)	61.63	
Max. Pressure (psi)	70.31	
Service Obv. @ Street Connection (m)	81.10	
Service Obv. @ Building Connection (m)	81.80	
Pressure Adjustment (psi)	-1.00	(due to service elevation difference from street to building)
Adjusted Min. Pressure (psi)	60.63	(must not be less than 40psi)
Adjusted Max. Pressure (psi)	69.31	(must not be more than 80psi)

Scenario 3: maximum daily demand + fire flow (from street connection to hydrant at northwest of site)

Q (L/s)	150.40	
C	150	
L (m.)	9.3	
I.D. (mm)	155	
V (m/s)	7.97	
h_f (m)	2.47	
Head Loss (psi)	3.51	
Pressure (psi)	57.80	
Service Obv. @ Street Connection (m)	81.12	
Service Obv. @ Hydrant Connection (m)	81.45	
Pressure Adjustment (psi)	-0.47	(due to service elevation difference from street to hydrant)
Adjusted Pressure (psi)	57.33	(must not be less than 20psi)

APPENDIX B
Sanitary Sewer Calculation Sheet



LRL File No. 170721
Project: 2465070 Ontario Ltd
Location: 2375 St-Laurent Blvd., Ottawa, ON
Date: December 13, 2017

Sanitary Design Parameters
 Average Daily Flow = 350 L/p/day
 Commercial & Institutional Flow = 50000 L/ha/day
 Light Industrial Flow = 35000 L/ha/day
 Heavy Industrial Flow = 55000 L/ha/day
 Maximum Residential Peak Factor = 4.0
 Commercial & Institutional Peak Factor = 1.5

Industrial Peak Factor = as per Appendix 4-B = 7.25
 Extraneous Flow = 0.28 L/s/gross ha

Pipe Design Parameters

Minimum Velocity = 0.60 m/s
 Manning's n = 0.013

LOCATION			RESIDENTIAL AREA AND POPULATION						COMMERCIAL		INDUSTRIAL			INSTITUTIONAL		C+I	INFILTRATION			TOTAL FLOW (l/s)	LENGTH (m)	DIA. (mm)	SLOPE (%)	PIPE				MANHOLE	
CATCHMENT / STREET	FROM MH	TO MH	AREA (Ha)	POP.	CUMMULATIVE		PEAK FACT.	PEAK FLOW (l/s)	AREA (Ha)	ACCU. AREA (Ha)	AREA (Ha)	ACCU. AREA (Ha)	PEAK FACT.	AREA (Ha)	ACCU. AREA (Ha)	PEAK FLOW (l/s)	TOTAL AREA (Ha)	ACCU. AREA (Ha)	INFILT. FLOW (l/s)					MATERIAL	CAP. (FULL) (l/s)	VEL. (FULL) (m/s)	Ratio (Q/Q _{FULL})	UP INVERT (m)	DOWN INVERT (m)
Site	Bldg	MH01	0.000	0.0	0.0	0.0	4.0	0.00	0.000	0.000	0.659	0.659	7.25	0.0	0.0	1.94	0.659	0.659	0.18	2.12	18.3	150	1.00%	PVC	15.23	0.86	0.14		
	MH01	TRUNK	0.000	0.0	0.0	0.0	4.0	0.00	0.000	0.000	0.000	0.659	7.25	0.0	0.0	1.94	0.000	0.659	0.18	2.12	16.8	150	1.00%	PVC	15.23	0.86	0.14		
NOTES																													
Existing inverts and slopes are estimated. They are to be confirmed on-site.														Designed:		PROJECT: 2465070 Ontario Ltd													
														Checked:		LOCATION: 2375 St-Laurent Blvd., Ottawa, ON													
														Dwg. Reference:		File Ref.: 170721				Date: December 13, 2017				Sheet No. 1 of 1					

APPENDIX C
Stormwater Management Design Sheets

LRL Associates Ltd.

Storm Design Sheet



LRL File No. 170721
Project: 2465070 Ontario Ltd
Location: 2375 St-Laurent, Ottawa, ON
Date: 13 Dec 2017
Designed: Guillaume Courtois
Drawing Reference: C701

Post-development Catchments

CATCHMENT	Grass C=0.20	Gravel C=0.80	Bldg. / Asph. / Conc. C=0.90	Total Area (ha)	Combined C
CA-01	0.054	0.000	0.303	0.357	0.79
CA-02	0.000	0.000	0.012	0.012	0.90
CA-03	0.007	0.000	0.097	0.104	0.85
CA-04	0.019	0.000	0.034	0.053	0.65
CA-05	0.021	0.000	0.058	0.079	0.71
CA-06	0.010	0.000	0.044	0.054	0.77



LRL File No. 170721
Project: 2465070 Ontario Ltd
Location: 2375 St-Laurent, Ottawa, ON
Date: 13 Dec 2017
Designed: Guillaume Courtois
Drawing Ref.: C701

**Stormwater Management
Design Sheet**

Allowable Release Rate (5 Year Pre-development)

Time of Concentration:

$T_c = G(1.1 - c)L^{0.5} / (100 \times S)^{1/3}$ as per FAA/Rational Method Equation
 where: $c = 0.5$ Runoff Coefficient as per City pre-consultation application memo
 $G = 3.26$ Constant
 $L = 137.65$ Longest watercourse length (in meters) in watershed
 $S = 0.0025$ Average slope of watercourse
 $T_c = 36$ min

Intensity:

$I_s = 998.071 / (T_c + 6.053)^{0.814}$ as per City of Ottawa Guidelines
 where: $T_c = 36$ Time of Concentration in min.
 $I_s = 47.2$ mm/hr

Allowable Release:

$Q = 2.78 \times C \times I \times A$
 where: $C = 0.5$ Runoff Coefficient as per City pre-consultation application memo
 $I = 47.2$ mm/hr
 $T_c = 36$ min
 Total Site Area = 0.659 ha
 $Q = 43.22$ L/s

Catchment Area and Runoff Coefficient (Post-development)

	Individual Watersheds	Total Area (ha)	Grass Area (ha)	Gravel Area (ha)	Bldg. / Asph. / Conc. Area (ha)	$\Sigma C * A$	C weighted (1:5 yr)	C weighted (1:100 yr)
Controlled	CA-1	0.357	0.054	0.000	0.303	0.284	0.79	0.99
	CA-2	0.012	0.000	0.000	0.012	0.011	0.90	1.00
	CA-3	0.104	0.007	0.000	0.097	0.089	0.85	1.00
	CA-4	0.053	0.019	0.000	0.034	0.034	0.65	0.81
	CA-5	0.079	0.021	0.000	0.058	0.056	0.71	0.89
	CA-6	0.054	0.010	0.000	0.044	0.042	0.77	0.96

					1:5 YEAR	1:100 YEAR	
Total Site Area =		0.659	ha	$\Sigma C =$	0.78	0.98	
Controlled	Bldg. / Asph. / Conc. Area =		0.548	ha	C =	0.90	1.00
	Gravel Area =		0.000	ha	C =	0.80	1.00
	Grass Area =		0.111	ha	C =	0.20	0.25
	Total Controlled =		0.659	ha	$\Sigma C =$	0.78	0.98



LRL File No. 170721
Project: 2465070 Ontario Ltd
Location: 2375 St-Laurent, Ottawa, ON
Date: 13 Dec 2017
Designed: Guillaume Courtois
Drawing Ref.: C701

**Stormwater Management
Design Sheet**

Post-development Stormwater Management

5 Year Post-development:

$I_5 = 998.071 / (Tc + 6.053)^{0.814}$
as per City of Ottawa Guidelines

where: I = intensity in mm/hr
 Tc = Time of Concentration

1:5 YEAR STORM EVENT					
Time (min)	Intensity (mm/hr)	Peak Flow (L/s)	Release Rate (L/s)	Storage Rate (L/s)	Storage Volume (m ³)
10	104.2	149.29	43.22	106.07	63.64
15	83.6	119.72	43.22	76.50	68.85
20	70.3	100.66	43.22	57.43	68.92
25	60.9	87.25	43.22	44.03	66.05
30	53.9	77.27	43.22	34.05	61.28
35	48.5	69.52	43.22	26.29	55.22
40	44.2	63.31	43.22	20.09	48.21
45	40.6	58.21	43.22	14.99	40.48
50	37.7	53.95	43.22	10.73	32.18
55	35.1	50.33	43.22	7.10	23.44
60	32.9	47.20	43.22	3.98	14.33

100 Year Post-development:

Intensity:
 $I_{100} = 1735.688 / (Tc + 6.014)^{0.820}$
as per City of Ottawa Guidelines

where: I = intensity in mm/hr
 Tc = Time of Concentration

1:100 YEAR STORM EVENT					
Time (min)	Intensity (mm/hr)	Peak Flow (L/s)	Release Rate (L/s)	Storage Rate (L/s)	Storage Volume (m ³)
10	178.6	319.80	43.22	276.58	165.95
15	142.9	255.93	43.22	212.70	191.43
20	120.0	214.83	43.22	171.61	205.93
25	103.8	185.99	43.22	142.77	214.15
30	91.9	164.54	43.22	121.32	218.37
35	82.6	147.90	43.22	104.68	219.82
40	75.1	134.59	43.22	91.36	219.27
45	69.1	123.67	43.22	80.45	217.21
50	64.0	114.54	43.22	71.32	213.96
55	59.6	106.79	43.22	63.57	209.76
60	55.9	100.11	43.22	56.89	204.79

Onsite Stormwater Retention

Total Storage Required =	219.82 m³	
Overland Ponding Storage =	62.78 m ³	refer to LRL Plan C601
Pipe Storage =	11.61 m ³	
Drainage Structures Storage =	15.02 m ³	
Stormtech Chambers Storage =	133.00 m ³	refer to LRL Plan C902
Total Available Storage =	222.41 m³	
Supplementary Storage Required =	0.00 m ³	

LRL Associates Ltd.
Storm Design Sheet



LRL File No. 170721
Project: 2465070 Ontario Ltd
Location: 2375 St-Laurent, Ottawa, ON
Date: 13 Dec 2017
Designed: Guillaume Courtois
Drawing Reference: C701

Rational Method Q = 2.78CIA

Q = Peak flow in litres per second (L/s)
 A = Drainage area in hectares (ha)
 C = Runoff coefficient
 I = Rainfall intensity (mm/hr)

Storm Design Parameters

Runoff Coefficient (C)
 Grass 0.2
 Gravel 0.8
 Bldg. / Asph. / Conc. 0.9

IDF Curve Ottawa Macdonald-Cartier International Airport
 Storm Event 5 years
 Formula $I = a / (T_c + b)^c$
 a = 998.07 b = 6.053 c = 0.814

Pipe Design Parameters

Minimum velocity = 0.80 m/s
 Maximum velocity = 3.00 m/s
 Manning's Coeff. "n" = 0.013

LOCATION			AREA (ha)			FLOW						STORM SEWER								MANHOLE			WATERSHED		AVAILABLE STORAGE								
CATCHMENT / STREET	From Structure	To Structure	Grass C=0.20	Gravel C=0.80	Bldg./Asph./Conc. C=0.90	Indiv. 2.78AC	Accum. 2.78AC	Time of Conc. (min.)	Rainfall Intensity (mm/hr)	Peak Flow Q (L/s)	ICD Controlled Flow Q (L/s)	Pipe Diameter (mm)	Type	Slope (%)	Length (m)	Capacity Full (L/s)	Spare Capacity (L/s)	Velocity Full (m/s)	Time of Flow (min.)	Ratio (Q/Q _{FULL})	Up Invert (m)	Down Invert (m)	T/G Up Stream (m)	T/G Down Stream (m)	Up Depth obv (m)	Down Depth obv (m)	Up Depth inv (m)	Total Area (ha)	Combined C	Pipe Storage (m ³)	Upstream CB/MH Size (m)	Water Depth (m)	CB/MH Storage (m ³)
CA-01	CBMH1	CBMH2	0.054	0.000	0.303	0.79	0.79	36.43	47.2	37.19		300	PVC	0.34%	45.0	56.39	19.20	0.80	0.94	0.66	80.95	80.80	83.25	83.30	2.00	2.20	2.30	0.357	0.79	3.18	1.20	2.30	2.60
CA-02	CB1	CBMH2	0.000	0.000	0.012	0.03	0.03	36.43	47.2	1.42		200	PVC	1.00%	16.0	32.80	31.38	1.04	0.26	0.04	81.03	80.87	82.93	83.30	1.70	2.23	1.90	0.012	0.90	0.50	0.60	1.90	0.68
CA-03	CBMH2	CBMH5	0.007	0.000	0.097	0.25	1.06	37.37	46.4	49.35		300	PVC	1.19%	28.5	105.49	56.14	1.49	0.32	0.47	80.77	80.43	83.30	83.30	2.23	2.57	2.53	0.104	0.85	2.01	1.20	2.53	2.86
CA-04	CBMH3	CBMH4	0.019	0.000	0.034	0.10	0.10	36.43	47.2	4.51		300	PVC	0.34%	63.2	56.39	51.87	0.80	1.32	0.08	80.95	80.74	83.25	83.30	2.00	2.26	2.30	0.053	0.65	4.47	1.20	2.30	2.60
CA-05	CBMH4	CBMH5	0.021	0.000	0.058	0.16	0.25	37.75	46.0	11.62		300	PVC	1.23%	20.4	107.25	95.63	1.52	0.22	0.11	80.68	80.43	83.30	83.30	2.32	2.57	2.62	0.079	0.71	1.44	1.20	2.62	2.96
CA-06	CBMH5	STC300	0.010	0.000	0.044	0.12	1.43	37.97	45.8	65.67	43.22	300	PVC	4.00%	5.0	193.40	150.18	2.74	0.03	0.22	80.37	80.17	83.30	83.54	2.63	3.07	2.93	0.054	0.77	N/A	1.20	2.93	3.31
	STC300	EX. MH	0.000	0.000	0.000	0.00	1.43	38.00	45.8	65.63	43.22	300	PVC	0.34%	16.3	56.39	13.16	0.80	0.34	0.77	80.10	80.04	83.54	83.37	3.14	3.03	3.44	N/A	N/A	N/A	N/A	N/A	N/A

11.61	15.02
HWL	83.47
Total Storage	26.63

APPENDIX D

Hydrovex Vertical Vortex Flow Regulator Report

CSO/STORMWATER MANAGEMENT



HYDROVEX[®] VHV / SVHV
Vertical Vortex Flow Regulator

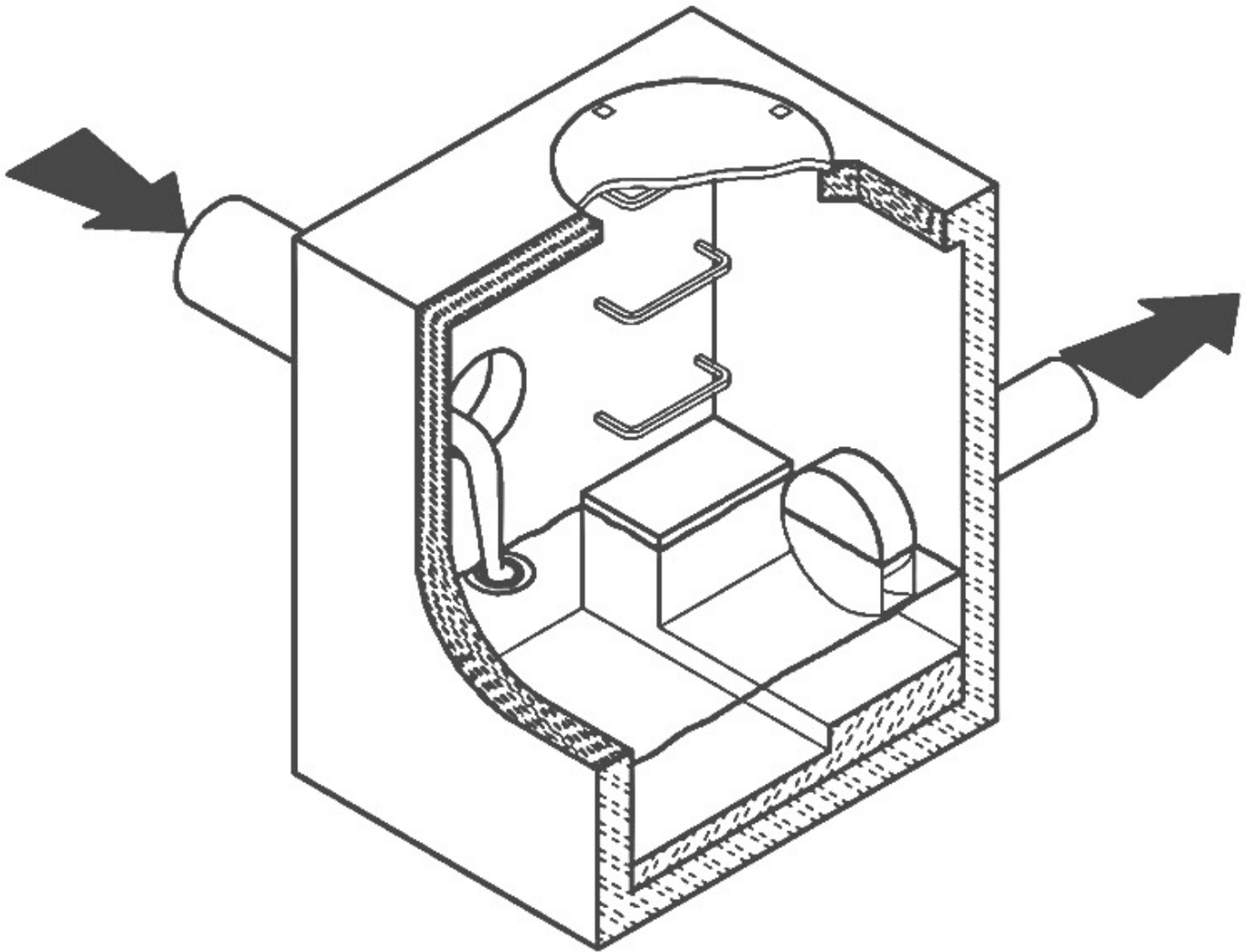

JOHN MEUNIER

HYDROVEX® VHV / SVHV VERTICAL VORTEX FLOW REGULATOR

APPLICATIONS

One of the major problems of urban wet weather flow management is the runoff generated after a heavy rainfall. During a storm, uncontrolled flows may overload the drainage system and cause flooding. Due to increased velocities, sewer pipe wear is increased dramatically and results in network deterioration. In a combined sewer system, the wastewater treatment plant may also experience significant increases in flows during storms, thereby losing its treatment efficiency.

A simple means of controlling excessive water runoff is by controlling excessive flows at their origin (manholes). **John Meunier Inc.** manufactures the **HYDROVEX® VHV / SVHV** line of vortex flow regulators to control stormwater flows in sewer networks, as well as manholes.

The vortex flow regulator design is based on the fluid mechanics principle of the forced vortex. This grants flow regulation without any moving parts, thus reducing maintenance. The operation of the regulator, depending on the upstream head and discharge, switches between orifice flow (gravity flow) and vortex flow. Although the concept is quite simple, over 12 years of research have been carried out in order to get a high performance.

The **HYDROVEX® VHV / SVHV** Vertical Vortex Flow Regulators (refer to **Figure 1**) are manufactured entirely of stainless steel, and consist of a hollow body (1) (in which flow control takes place) and an outlet orifice (7). Two rubber "O" rings (3) seal and retain the unit inside the outlet pipe. Two stainless steel retaining rings (4) are welded on the outlet sleeve to ensure that there is no shifting of the "O" rings during installation and use.

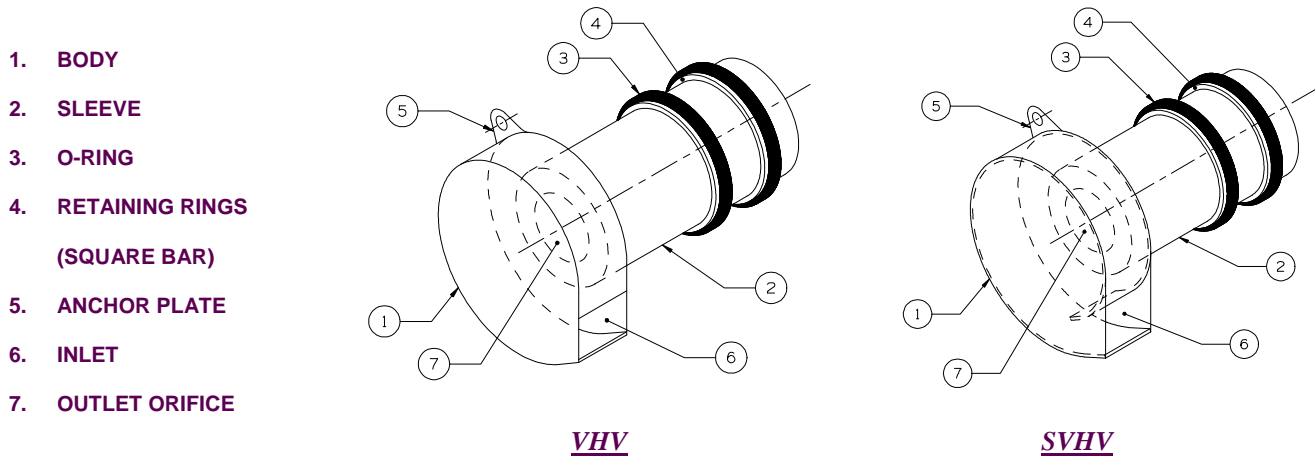

FIGURE 1: HYDROVEX® VHV-SVHV VERTICAL VORTEX FLOW REGULATORS

ADVANTAGES

- The **HYDROVEX® VHV / SVHV** line of flow regulators are manufactured entirely of stainless steel, making them durable and corrosion resistant.
- Having no moving parts, they require minimal maintenance.
- The geometry of the **HYDROVEX® VHV / SVHV** flow regulators allows a control equal to an orifice plate, having a cross section area 4 to 6 times smaller. This decreases the chance of blockage of the regulator, due to sediments and debris found in stormwater flows. **Figure 2** illustrates the comparison between a regulator model 100 SVHV-2 and an equivalent orifice plate. One can see that for the same height of water, the regulator controls a flow approximately four times smaller than an equivalent orifice plate.
- Installation of the **HYDROVEX® VHV / SVHV** flow regulators is quick and straightforward and is performed after all civil works are completed.
- Installation requires no special tools or equipment and may be carried out by any contractor.
- Installation may be carried out in existing structures.

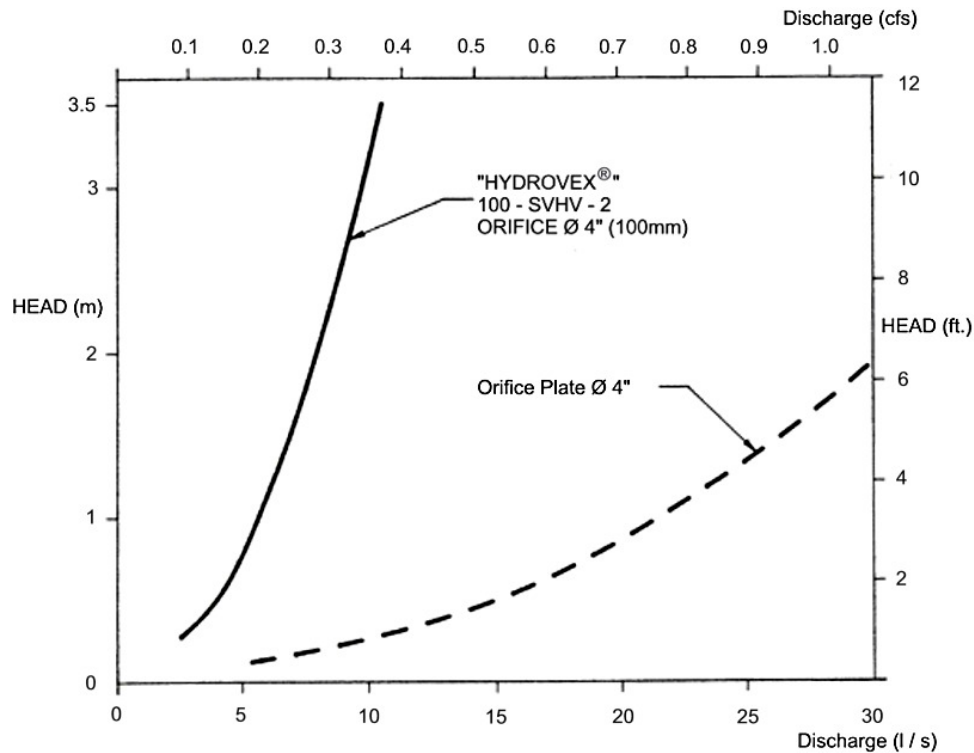

FIGURE 2: DISCHARGE CURVE SHOWING A HYDROVEX® FLOW REGULATOR VS AN ORIFICE PLATE

SELECTION

Selection of a **VHV** or **SVHV** regulator can be easily made using the selection charts found at the back of this brochure (see **Figure 3**). These charts are a graphical representation of the maximum upstream water pressure (head) and the maximum discharge at the manhole outlet. The maximum design head is the difference between the maximum upstream water level and the invert of the outlet pipe. All selections should be verified by John Meunier Inc. personnel prior to fabrication.

Example:

- ✓ Maximum design head 2m (6.56 ft.)
- ✓ Maximum discharge 6 L/s (0.2 cfs)
- ✓ Using **Figure 3** - VHV model required is a **75 VHV-1**

INSTALLATION REQUIREMENTS

All **HYDROVEX®** **VHV** / **SVHV** flow regulators can be installed in circular or square manholes. **Figure 4** gives the various minimum dimensions required for a given regulator. *It is imperative to respect the minimum clearances shown to ensure easy installation and proper functioning of the regulator.*

SPECIFICATIONS

In order to specify a **HYDROVEX**[®] regulator, the following parameters must be defined:

- The model number (ex: 75-VHV-1)
- The diameter and type of outlet pipe (ex: 6" diam. SDR 35)
- The desired discharge (ex: 6 l/s or 0.21 CFS)
- The upstream head (ex: 2 m or 6.56 ft.) *
- The manhole diameter (ex: 36" diam.)
- The minimum clearance "H" (ex: 10 inches)
- The material type (ex: 304 s/s, 11 Ga. standard)

* *Upstream head is defined as the difference in elevation between the maximum upstream water level and the invert of the outlet pipe where the **HYDROVEX**[®] flow regulator is to be installed.*

PLEASE NOTE THAT WHEN REQUESTING A PROPOSAL, WE SIMPLY REQUIRE THAT YOU PROVIDE US WITH THE FOLLOWING:

- *project design flow rate*
- *pressure head*
- *chamber's outlet pipe diameter and type*



Typical VHV model in factory

OPTIONS



FV – SVHV (mounted on sliding plate)



VHV-1-O (standard model with odour control inlet)

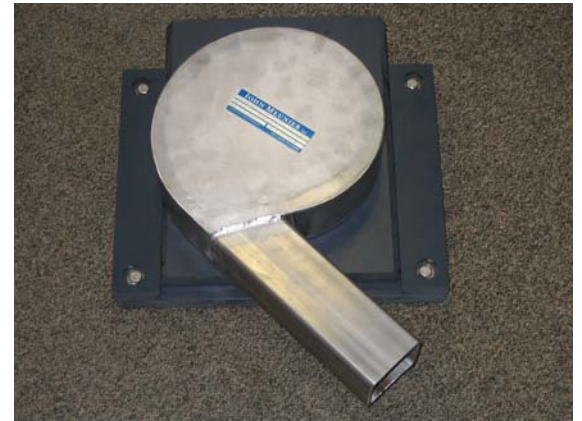

FV – VHV-O (mounted on sliding plate with odour control inlet)



VHV with Gooseneck assembly in existing chamber without minimum release at the bottom



VHV with air vent for minimal slopes



VHV Vertical Vortex Flow Regulator

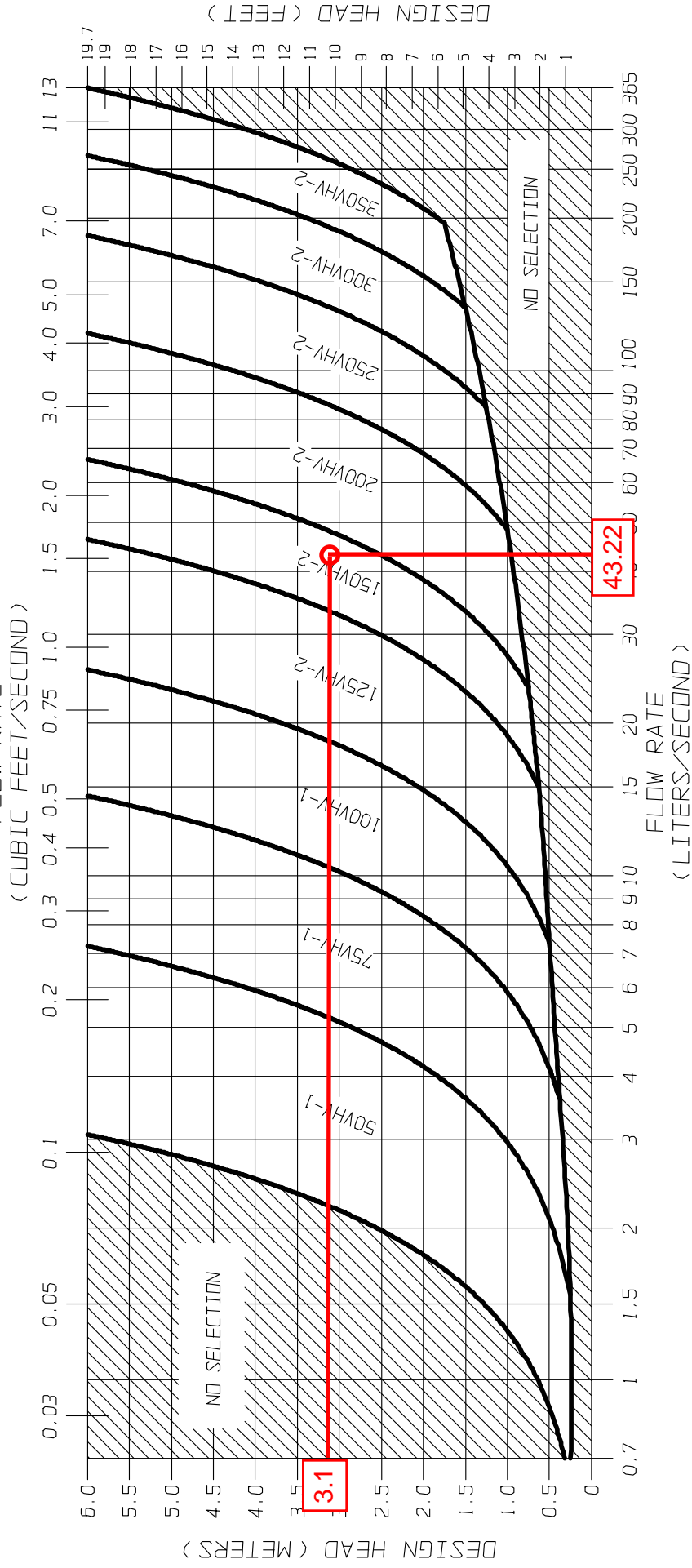
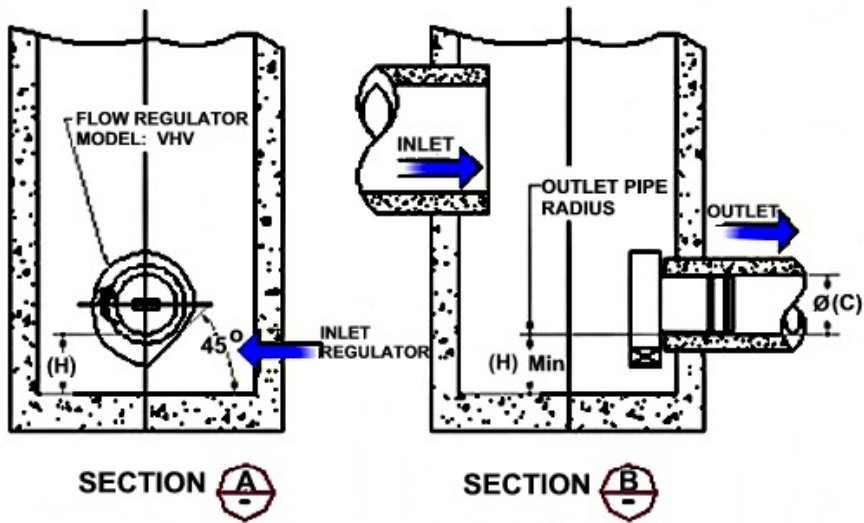
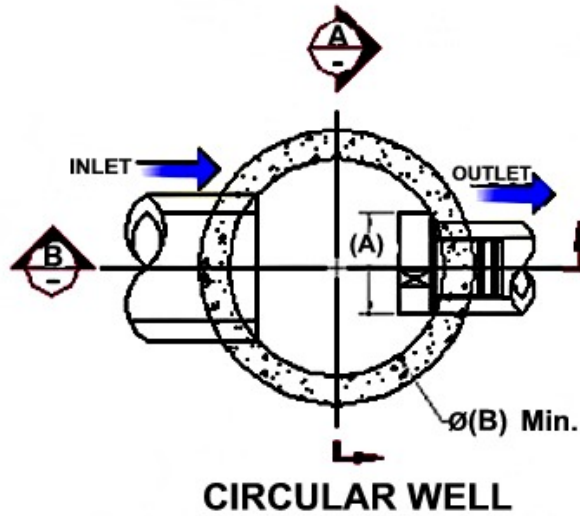

FIGURE 3 - VHV

JOHN MEUNIER

**FLOW REGULATOR TYPICAL INSTALLATION IN CIRCULAR MANHOLE
FIGURE 4 (MODEL VHV)**

Model Number	Regulator Diameter		Minimum Manhole Diameter		Minimum Outlet Pipe Diameter		Minimum Clearance	
	A (mm)	A (in.)	B (mm)	B (in.)	C (mm)	C (in.)	H (mm)	H (in.)
50VHV-1	150	6	600	24	150	6	150	6
75VHV-1	250	10	600	24	150	6	150	6
100VHV-1	325	13	900	36	150	6	200	8
125VHV-2	275	11	900	36	150	6	200	8
150VHV-2	350	14	900	36	150	6	225	9
200VHV-2	450	18	1200	48	200	8	300	12
250VHV-2	575	23	1200	48	250	10	350	14
300VHV-2	675	27	1600	64	250	10	400	16
350VHV-2	800	32	1800	72	300	12	500	20



INSTALLATION

The installation of a **HYDROVEX**[®] regulator may be undertaken once the manhole and piping is in place. Installation consists of simply fitting the regulator into the outlet pipe of the manhole. **John Meunier Inc.** recommends the use of a lubricant on the outlet pipe, in order to facilitate the insertion and orientation of the flow controller.

MAINTENANCE

HYDROVEX[®] regulators are manufactured in such a way as to be maintenance free; however, a periodic inspection (every 3-6 months) is suggested in order to ensure that neither the inlet nor the outlet has become blocked with debris. The manhole should undergo periodically, particularly after major storms, inspection and cleaning as established by the municipality

GUARANTY

The **HYDROVEX**[®] line of **VHV / SVHV** regulators are guaranteed against both design and manufacturing defects for a period of 5 years. Should a unit be defective, **John Meunier Inc.** is solely responsible for either modification or replacement of the unit.

John Meunier Inc.

ISO 9001 : 2008

Head Office

4105 Sartelon
Saint-Laurent (Quebec) Canada H4S 2B3
Tel.: 514-334-7230 www.johnmeunier.com
Fax: 514-334-5070 cs@johnmeunier.com

Ontario Office

2000 Argentia Road, Plaza 4, Unit 430
Mississauga (Ontario) Canada L5N 1W1
Tel.: 905-286-4846 www.johnmeunier.com
Fax: 905-286-0488 ontario@johnmeunier.com

USA Office

2209 Menlo Avenue
Glenside, PA USA 19038
Tel.: 412-417-6614 www.johnmeunier.com
Fax: 215-885-4741 astele@johnmeunier.com

APPENDIX E
StormTech System Design Sheets



ADVANCED DRAINAGE SYSTEMS, INC.



2465070 ONTARIO LTD

2375 ST-LAURENT BLVD., OTTAWA, ON

STORMTECH CHAMBER SPECIFICATIONS

1. CHAMBERS SHALL BE STORMTECH MC-3500 OR APPROVED EQUAL.
2. CHAMBERS SHALL BE MADE FROM VIRGIN, IMPACT-MODIFIED POLYPROPYLENE COPOLYMERS.
3. CHAMBER ROWS SHALL PROVIDE CONTINUOUS, UNOBSTRUCTED INTERNAL SPACE WITH NO INTERNAL SUPPORT PANELS THAT WOULD IMPEDE FLOW OR LIMIT ACCESS FOR INSPECTION.
4. THE STRUCTURAL DESIGN OF THE CHAMBERS, THE STRUCTURAL BACKFILL, AND THE INSTALLATION REQUIREMENTS SHALL ENSURE THAT THE LOAD FACTORS SPECIFIED IN THE AASHTO LRFD BRIDGE DESIGN SPECIFICATIONS, SECTION 12.12, ARE MET FOR: 1) LONG-DURATION DEAD LOADS AND 2) SHORT-DURATION LIVE LOADS, BASED ON THE AASHTO DESIGN TRUCK WITH CONSIDERATION FOR IMPACT AND MULTIPLE VEHICLE PRESENCES.
5. CHAMBERS SHALL MEET THE REQUIREMENTS OF ASTM F2418, "STANDARD SPECIFICATION FOR POLYPROPYLENE (PP) CORRUGATED WALL STORMWATER COLLECTION CHAMBERS".
6. CHAMBERS SHALL BE DESIGNED AND ALLOWABLE LOADS DETERMINED IN ACCORDANCE WITH ASTM F2787, "STANDARD PRACTICE FOR STRUCTURAL DESIGN OF THERMOPLASTIC CORRUGATED WALL STORMWATER COLLECTION CHAMBERS".
7. ONLY CHAMBERS THAT ARE APPROVED BY THE SITE DESIGN ENGINEER WILL BE ALLOWED. THE CHAMBER MANUFACTURER SHALL SUBMIT THE FOLLOWING UPON REQUEST TO THE SITE DESIGN ENGINEER FOR APPROVAL BEFORE DELIVERING CHAMBERS TO THE PROJECT SITE:
 - a. A STRUCTURAL EVALUATION SEALED BY A REGISTERED PROFESSIONAL ENGINEER THAT DEMONSTRATES THAT THE SAFETY FACTORS ARE GREATER THAN OR EQUAL TO 1.95 FOR DEAD LOAD AND 1.75 FOR LIVE LOAD, THE MINIMUM REQUIRED BY ASTM F2787 AND BY AASHTO FOR THERMOPLASTIC PIPE.
 - b. A STRUCTURAL EVALUATION SEALED BY A REGISTERED PROFESSIONAL ENGINEER THAT DEMONSTRATES THAT THE LOAD FACTORS SPECIFIED IN THE AASHTO LRFD BRIDGE DESIGN SPECIFICATIONS, SECTION 12.12, ARE MET. THE 50 YEAR CREEP MODULUS DATA SPECIFIED IN ASTM F2418 MUST BE USED AS PART OF THE AASHTO STRUCTURAL EVALUATION TO VERIFY LONG-TERM PERFORMANCE.
 - c. STRUCTURAL CROSS SECTION DETAIL ON WHICH THE STRUCTURAL EVALUATION IS BASED.
8. CHAMBERS AND END CAPS SHALL BE PRODUCED AT AN ISO 9001 CERTIFIED MANUFACTURING FACILITY.

IMPORTANT - NOTES FOR THE BIDDING AND INSTALLATION OF MC-3500 CHAMBER SYSTEM

1. STORMTECH MC-3500 CHAMBERS SHALL NOT BE INSTALLED UNTIL THE MANUFACTURER'S REPRESENTATIVE HAS COMPLETED A PRE-CONSTRUCTION MEETING WITH THE INSTALLERS.
2. STORMTECH MC-3500 CHAMBERS SHALL BE INSTALLED IN ACCORDANCE WITH THE "STORMTECH MC-3500/MC-4500 CONSTRUCTION GUIDE".
3. CHAMBERS ARE NOT TO BE BACKFILLED WITH A DOZER OR AN EXCAVATOR SITUATED OVER THE CHAMBERS.

STORMTECH RECOMMENDS 3 BACKFILL METHODS:
 - STONESHOOTER LOCATED OFF THE CHAMBER BED.
 - BACKFILL AS ROWS ARE BUILT USING AN EXCAVATOR ON THE FOUNDATION STONE OR SUBGRADE.
 - BACKFILL FROM OUTSIDE THE EXCAVATION USING A LONG BOOM HOE OR EXCAVATOR.
4. THE FOUNDATION STONE SHALL BE LEVELED AND COMPACTED PRIOR TO PLACING CHAMBERS.
5. JOINTS BETWEEN CHAMBERS SHALL BE PROPERLY SEATED PRIOR TO PLACING STONE.
6. MAINTAIN MINIMUM - 9" (230 mm) SPACING BETWEEN THE CHAMBER ROWS.
7. INLET AND OUTLET MANIFOLDS MUST BE INSERTED A MINIMUM OF 12" (300 mm) INTO CHAMBER END CAPS.
8. EMBEDMENT STONE SURROUNDING CHAMBERS MUST BE A CLEAN, CRUSHED, ANGULAR STONE 3/4-2" (20-50 mm) MEETING THE AASHTO M43 DESIGNATION OF #3 OR #4.^{^J}
9. STONE MUST BE PLACED ON THE TOP CENTER OF THE CHAMBER TO ANCHOR THE CHAMBERS IN PLACE AND PRESERVE ROW SPACING.^{^J}
10. ADS RECOMMENDS THE USE OF "FLEXSTORM CATCH IT" INSERTS DURING CONSTRUCTION FOR ALL INLETS TO PROTECT THE SUBSURFACE STORMWATER MANAGEMENT SYSTEM FROM CONSTRUCTION SITE RUNOFF.

NOTES FOR CONSTRUCTION EQUIPMENT

1. STORMTECH MC-3500 CHAMBERS SHALL BE INSTALLED IN ACCORDANCE WITH THE "STORMTECH MC-3500/MC-4500 CONSTRUCTION GUIDE".^{^J}
2. THE USE OF EQUIPMENT OVER MC-3500 CHAMBERS IS LIMITED:
 - NO EQUIPMENT IS ALLOWED ON BARE CHAMBERS.
 - NO RUBBER Tired LOADER, DUMP TRUCK, OR EXCAVATORS ARE ALLOWED UNTIL PROPER FILL DEPTHS ARE REACHED IN ACCORDANCE WITH THE "STORMTECH MC-3500/MC-4500 CONSTRUCTION GUIDE".
 - WEIGHT LIMITS FOR CONSRUCTION EQUIPMENT CAN BE FOUND IN THE "STORMTECH MC-3500/MC-4500 CONSTRUCTION GUIDE".
3. FULL 36" (900 mm) OF STABILIZED COVER MATERIALS OVER THE CHAMBERS IS REQUIRED FOR DUMP TRUCK TRAVEL OR DUMPING.^{^J}
USE OF A DOZER TO PUSH EMBEDMENT STONE BETWEEN THE ROWS OF CHAMBERS MAY CAUSE DAMAGE TO CHAMBERS AND IS NOT AN ACCEPTABLE BACKFILL METHOD. ANY CHAMBERS DAMAGED BY USING THE "DUMP AND PUSH" METHOD ARE NOT COVERED UNDER THE STORMTECH STANDARD WARRANTY.

CONTACT STORMTECH AT 1-888-892-2694 WITH ANY QUESTIONS ON INSTALLATION REQUIREMENTS OR WEIGHT LIMITS FOR CONSTRUCTION EQUIPMENT.

CONCEPTUAL LAYOUT

(23) STORMTECH MC-3500 CHAMBERS
 (4) STORMTECH MC-3500 END CAPS
 INSTALLED WITH 305 mm COVER STONE, 229 mm BASE STONE, 40% STONE VOID
INSTALLED SYSTEM VOLUME: 133 m³
 AREA OF SYSTEM: 133 m²
 PERIMETER OF SYSTEM: 68 m

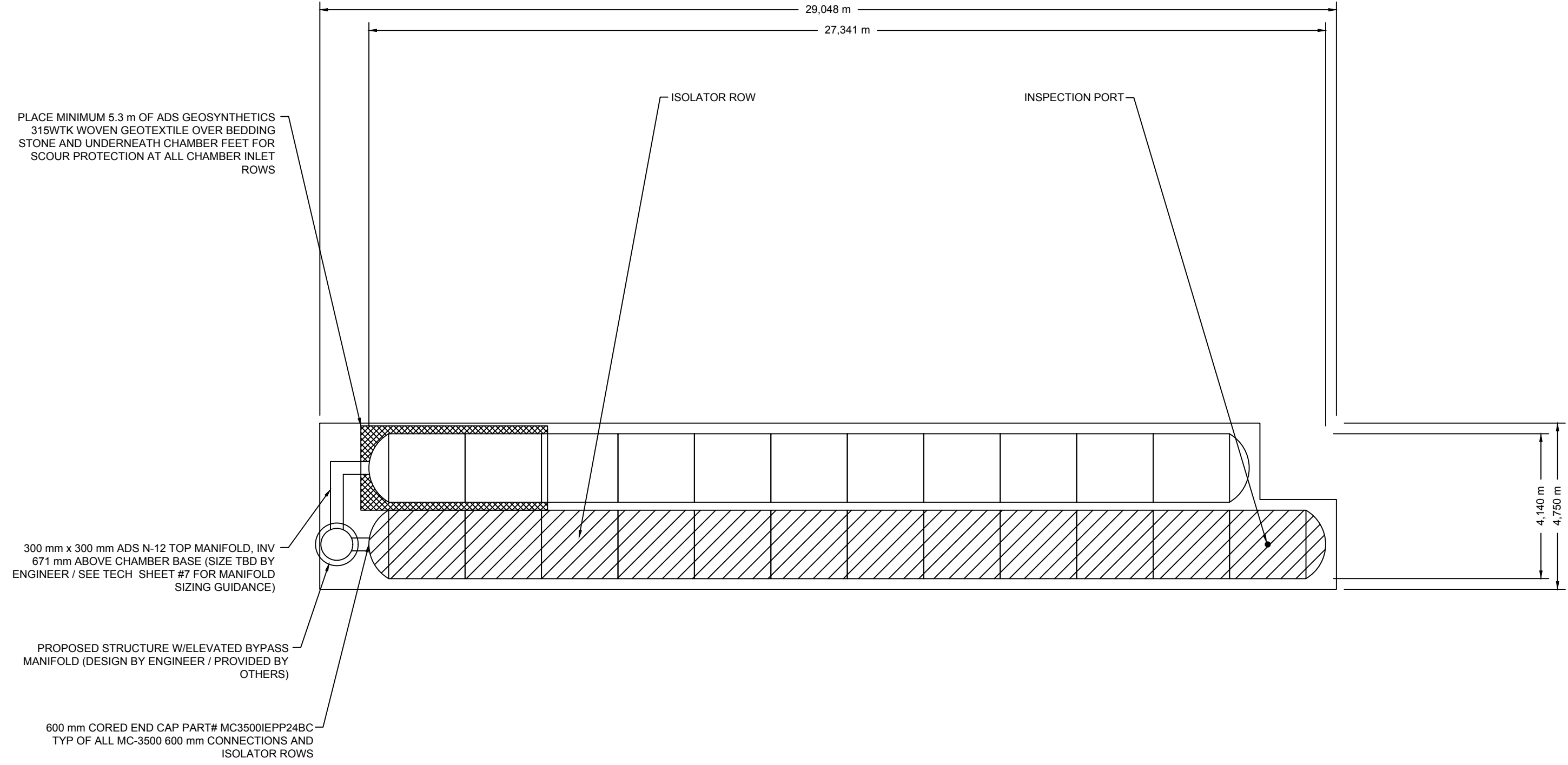

REV	DRW	CHK	DESCRIPTION

StormTech
 Determination Retention Water Quality
 70 INWOOD ROAD, SUITE 3 | ROCKY HILL | CT | 06867
 860-528-8188 | 888-892-2694 | WWW.STORMTECH.COM

ADS
 ADVANCED DRAINAGE SYSTEMS, INC.
 4640 TRUJEMAN BLVD
 HILLIARD, OH 43026
 1-800-733-7473

NOT TO SCALE

THIS DRAWING HAS BEEN PREPARED BASED ON INFORMATION PROVIDED TO ADS UNDER THE DIRECTION OF THE SITE DESIGN ENGINEER OR OTHER PROJECT REPRESENTATIVE. THE SITE DESIGN ENGINEER SHALL REVIEW THIS DRAWING PRIOR TO CONSTRUCTION. IT IS THE ULTIMATE RESPONSIBILITY OF THE SITE DESIGN ENGINEER TO ENSURE THAT THE PRODUCT(S) DEPICTED AND ALL ASSOCIATED DETAILS MEET ALL APPLICABLE LAWS, REGULATIONS, AND PROJECT REQUIREMENTS.

2465070 ONTARIO LTD
 2375 ST-LAURENT BLVD., OTTAWA,
 DATE: 12/06/2017 DRAWN: GC
 PROJECT #: Tool CHECKED: ---

ACCEPTABLE FILL MATERIALS: STORMTECH MC-3500 CHAMBER SYSTEMS

		BEGIN COMPACTIONS AFTER 24" (600 mm) OF MATERIAL OVER THE CHAMBERS IS REACHED. COMPACT ADDITIONAL LAYERS IN 12" (300 mm) MAX LIFTS TO A MIN. 95% PROCTOR DENSITY FOR WELL GRADED MATERIAL AND 95% RELATIVE DENSITY FOR PROCESSED AGGREGATE MATERIALS.	EMBEDMENT STONE: FILL SURROUNDING THE CHAMBERS FROM THE FOUNDATION STONE ('A' LAYER) TO THE 'C' LAYER ABOVE.	CLEAN, CRUSHED, ANGULAR STONE, NOMINAL SIZE DISTRIBUTION BETWEEN 3/4-2 INCH (20-50 mm)	AASHTO M43 ¹ 3, 4
D	A		FOUNDATION STONE: FILL BELOW CHAMBERS FROM THE SUBGRADE UP TO THE FOOT (BOTTOM) OF THE CHAMBER.	CLEAN, CRUSHED, ANGULAR STONE, NOMINAL SIZE DISTRIBUTION BETWEEN 3/4-2 INCH (20-50 mm)	AASHTO M43 ¹ 3, 4 NO COMPACTION REQUIRED.
PLATE COMPACT OR ROLL TO FINISH		INITIAL FILL: FILL MATERIAL FOR LAYER 'C' STARTS FROM THE TOP OF THE EMBEDMENT STONE ('B' LAYER) TO 24" (600 mm) ABOVE THE TOP OF THE CHAMBER. NOTE THAT PAVEMENT SUBBASE MAY BE A PART OF THE 'C' LAYER.	GRANULAR WELL-GRADED SOIL/AGGREGATE MIXTURES, <35% FINES OR PROCESSED AGGREGATE.		
		1. THE LISTED AASHTO DESIGNATIONS ARE FOR PAVEMENTS ONLY. THE STONE MUST ALSO BE CLEAN, CRUSHED, ANGULAR NO. 4 (AASHTO M43) STONE. 2. STORMTECH COMPACTION REQUIREMENTS ARE MET FOR 'A' LOCATION MATERIALS WHEN PLACED AND COMPACTED IN 9" (230 mm) (MAX) LIFTS USING TWO FULL COVERAGES WITH A VIBRATORY COMPACTOR. 3. CEV WHERE INFILTRATION SURFACES MAY BE COMPROMISED BY COMPACTION, FOR STANDARD DESIGN LOAD CONDITIONS A FLAT SURFACE MAY BE ACHIEVED BY RAKING OR DRAGGING WITHOUT COMPACTION EQUIPMENT. FOR SPECIAL LOAD DESIGNS, CONTACT STORMTECH FOR COMPACTION REQUIREMENTS.	MOST PAVEMENT SUBBASE MATERIALS CAN BE USED IN LIEU OF THIS LAYER. FOR EXAMPLE, A SPECIFICATION FOR #4 STONE WOULD STATE: "CLEAN, CRUSHED, ANGULAR NO. 4 (AASHTO M43) STONE."		
		ADS GEOSYNTHETICS 601T NON-WOVEN GEOTEXTILE ALL AROUND CLEAN, CRUSHED, ANGULAR STONE IN A & B LAYERS		PAVEMENT LAYER (DESIGNED BY SITE DESIGN ENGINEER)	

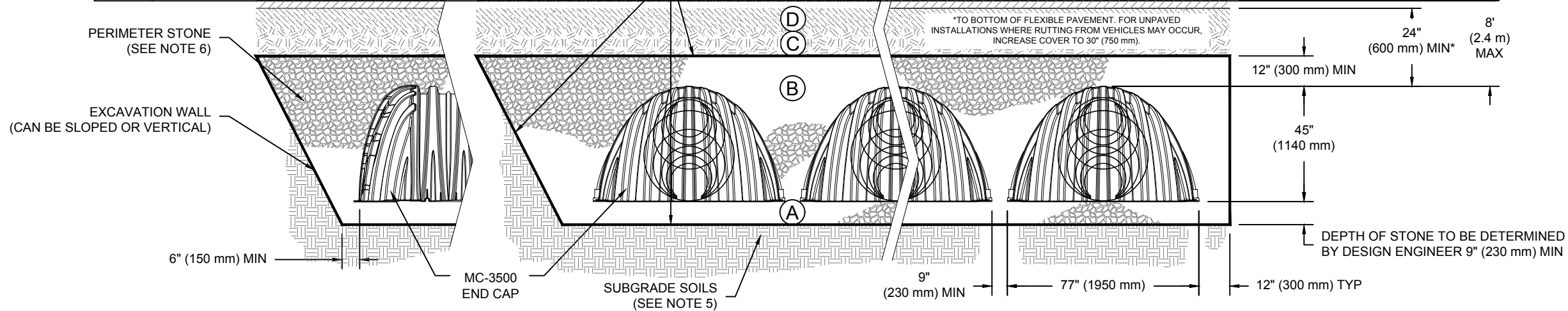

NOTES:

1. MC-3500 CHAMBERS SHALL CONFORM TO THE REQUIREMENTS OF ASTM F2418 "STANDARD SPECIFICATION FOR POLYPROPYLENE (PP) CORRUGATED WALL STORMWATER COLLECTION CHAMBERS".^J
2. MC-3500 CHAMBERS SHALL BE DESIGNED IN ACCORDANCE WITH ASTM F2787 "STANDARD PRACTICE FOR STRUCTURAL DESIGN OF THERMOPLASTIC CORRUGATED WALL STORMWATER COLLECTION CHAMBERS".^J
3. "ACCEPTABLE FILL MATERIALS" TABLE ABOVE PROVIDES MATERIAL LOCATIONS, DESCRIPTIONS, GRADATIONS, AND COMPACTION REQUIREMENTS FOR FOUNDATION, EMBEDMENT, AND FILL MATERIALS.^J
4. THE "SITE DESIGN ENGINEER" REFERS TO THE ENGINEER RESPONSIBLE FOR THE DESIGN AND LAYOUT OF THE STORMTECH CHAMBERS FOR THIS PROJECT.^J
5. THE SITE DESIGN ENGINEER IS RESPONSIBLE FOR ASSESSING THE BEARING RESISTANCE (ALLOWABLE BEARING CAPACITY) OF THE SUBGRADE SOILS AND THE DEPTH OF FOUNDATION STONE WITH CONSIDERATION FOR THE RANGE OF EXPECTED SOIL MOISTURE CONDITIONS.^J
6. PERIMETER STONE MUST BE EXTENDED HORIZONTALLY TO THE EXCAVATION WALL FOR BOTH VERTICAL AND SLOPED EXCAVATION WALLS.
7. ONCE LAYER 'C' IS PLACED, ANY SOIL/MATERIAL CAN BE PLACED IN LAYER 'D' UP TO THE FINISHED GRADE. MOST PAVEMENT SUBBASE SOILS CAN BE USED TO REPLACE THE MATERIAL REQUIREMENTS OF LAYER 'C' OR 'D' AT THE SITE DESIGN ENGINEER'S DISCRETION.

2465070 ONTARIO LTD	2375 ST-LAURENT BLVD., OTTAWA,
DATE: 12/06/2017	DRAWN: GC
PROJECT #: Tool	CHECKED: ---

REV	DRW	CHK	DESCRIPTION

StormTech
Dedication. Retention. Water Quality.

70 INWOOD ROAD, SUITE 3 | ROCKY HILL | CT | 06867
860-525-8188 | 888-892-2694 | WWW.STORMTECH.COM

4640 TRUEMAN BLVD
HILLIARD, OH 43026
1-800-733-7473

ADS
ADVANCED DRAINAGE SYSTEMS, INC.

THIS DRAWING HAS BEEN PREPARED BASED ON INFORMATION PROVIDED TO ADS UNDER THE DIRECTION OF THE SITE DESIGN ENGINEER OR OTHER PROJECT REPRESENTATIVE. THE SITE DESIGN ENGINEER SHALL REVIEW THIS DRAWING PRIOR TO CONSTRUCTION. IT IS THE ULTIMATE RESPONSIBILITY OF THE SITE DESIGN ENGINEER TO ENSURE THAT THE PRODUCT(S) DEPICTED AND ALL ASSOCIATED DETAILS MEET ALL APPLICABLE LAWS, REGULATIONS, AND PROJECT REQUIREMENTS.

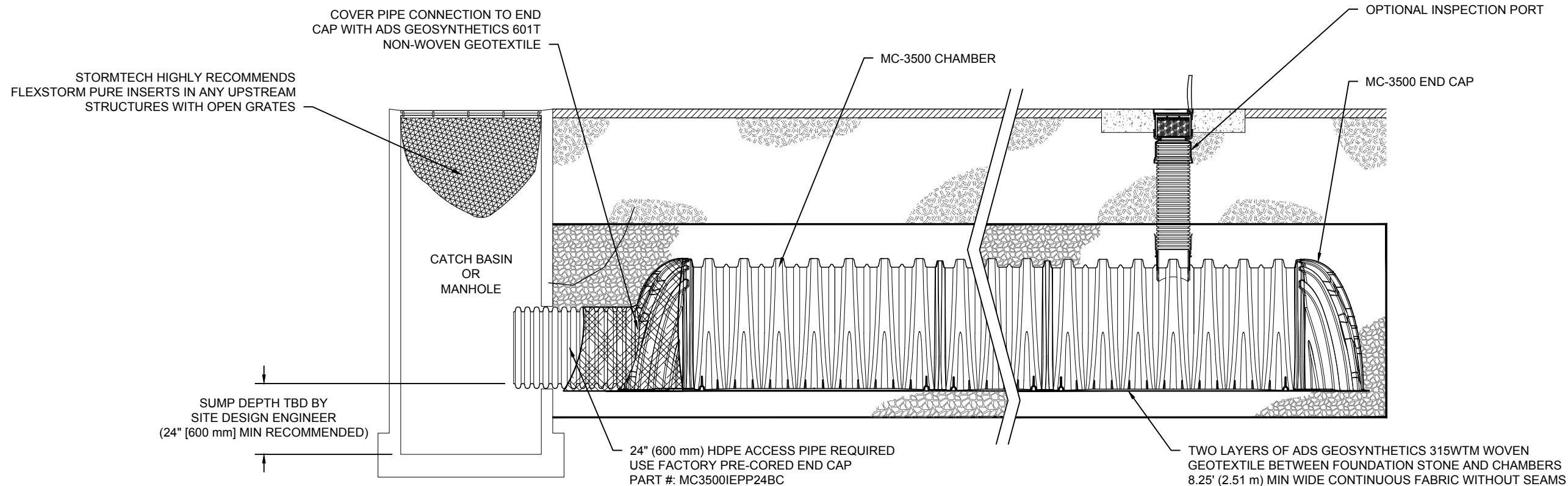

MC-3500 ISOLATOR ROW DETAIL
NTS

INSPECTION & MAINTENANCE

- STEP 1) INSPECT ISOLATOR ROW FOR SEDIMENT
- A. INSPECTION PORTS (IF PRESENT)
 - A.1. REMOVE/OPEN LID ON NYLOPLAST INLINE DRAIN
 - A.2. REMOVE AND CLEAN FLEXSTORM FILTER IF INSTALLED
 - A.3. USING A FLASHLIGHT AND STADIA ROD, MEASURE DEPTH OF SEDIMENT AND RECORD ON MAINTENANCE LOG
 - A.4. LOWER A CAMERA INTO ISOLATOR ROW FOR VISUAL INSPECTION OF SEDIMENT LEVELS (OPTIONAL)
 - A.5. IF SEDIMENT IS AT, OR ABOVE, 3" (80 mm) PROCEED TO STEP 2. IF NOT, PROCEED TO STEP 3.
 - B. ALL ISOLATOR ROWS
 - B.1. REMOVE COVER FROM STRUCTURE AT UPSTREAM END OF ISOLATOR ROW
 - B.2. USING A FLASHLIGHT, INSPECT DOWN THE ISOLATOR ROW THROUGH OUTLET PIPE^Ji) MIRRORS ON POLES OR CAMERAS MAY BE USED TO AVOID A CONFINED SPACE ENTRY^Jii) FOLLOW OSHA REGULATIONS FOR CONFINED SPACE ENTRY IF ENTERING MANHOLE
 - B.3. IF SEDIMENT IS AT, OR ABOVE, 3" (80 mm) PROCEED TO STEP 2. IF NOT, PROCEED TO STEP 3.
- STEP 2) CLEAN OUT ISOLATOR ROW USING THE JETVAC PROCESS
- A. A FIXED CULVERT CLEANING NOZZLE WITH REAR FACING SPREAD OF 45" (1.1 m) OR MORE IS PREFERRED
 - B. APPLY MULTIPLE PASSES OF JETVAC UNTIL BACKFLUSH WATER IS CLEAN
 - C. VACUUM STRUCTURE SUMP AS REQUIRED
- STEP 3) REPLACE ALL COVERS, GRATES, FILTERS, AND LIDS; RECORD OBSERVATIONS AND ACTIONS.
- STEP 4) INSPECT AND CLEAN BASINS AND MANHOLES UPSTREAM OF THE STORMTECH SYSTEM.

NOTES

1. INSPECT EVERY 6 MONTHS DURING THE FIRST YEAR OF OPERATION. ADJUST THE INSPECTION INTERVAL BASED ON PREVIOUS OBSERVATIONS OF SEDIMENT ACCUMULATION AND HIGH WATER ELEVATIONS.^J
2. CONDUCT JETTING AND VACTORING ANNUALLY OR WHEN INSPECTION SHOWS THAT MAINTENANCE IS NECESSARY.

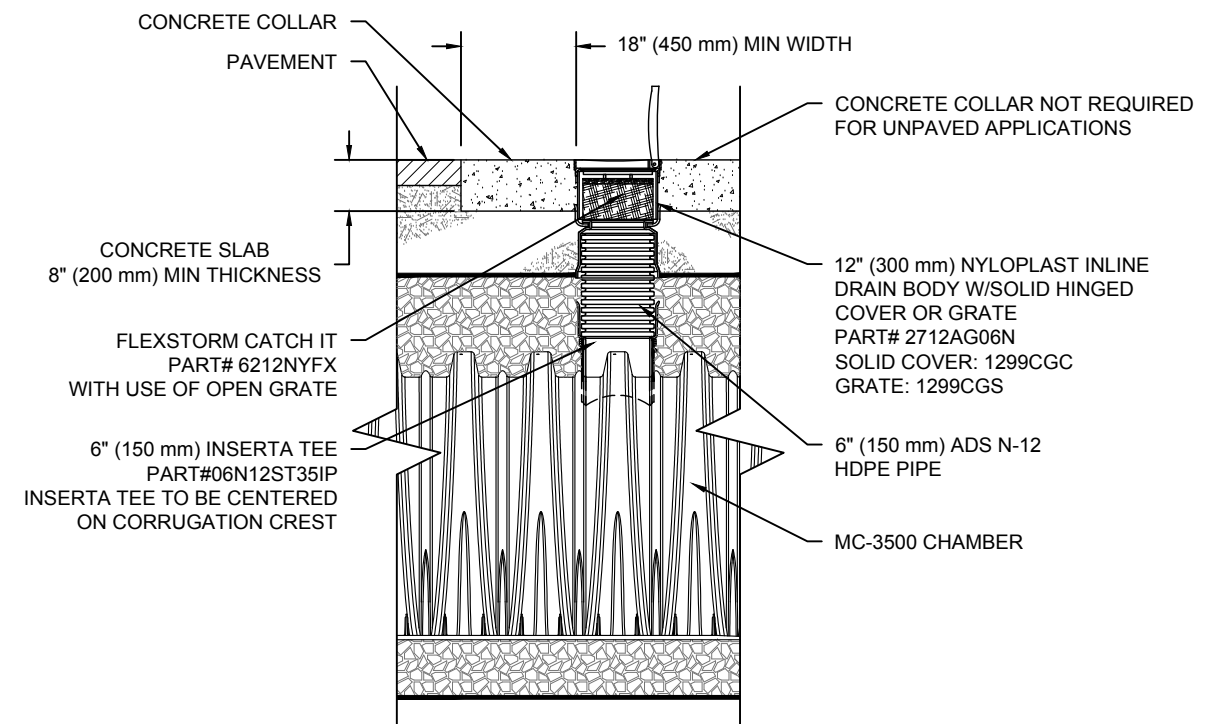

MC-3500 6" INSPECTION PORT DETAIL
NTS

2465070 ONTARIO LTD	2375 ST-LAURENT BLVD., OTTAWA,	DATE: 12/06/2017	DRAWN: GC	CHECKED: ---
DESCRIPTION		PROJECT #:	Tool	
DRW	CHK			
REV				

StormTech
Determination, Retention, Water Quality

70 INWOOD ROAD, SUITE 3 | ROCKY HILL | CT | 06067
860-525-8188 | 888-892-2694 | WWW.STORMTECH.COM

4640 TRUEMAN BLVD
HILLIARD, OH 43026
1-800-733-7473

ADS
ADVANCED DRAINAGE SYSTEMS, INC.

THIS DRAWING HAS BEEN PREPARED BASED ON INFORMATION PROVIDED TO ADS UNDER THE DIRECTION OF THE SITE DESIGN ENGINEER OR OTHER PROJECT REPRESENTATIVE. THE SITE DESIGN ENGINEER SHALL REVIEW THIS DRAWING PRIOR TO CONSTRUCTION. IT IS THE ULTIMATE RESPONSIBILITY OF THE SITE DESIGN ENGINEER TO ENSURE THAT THE PRODUCT(S) DEPICTED AND ALL ASSOCIATED DETAILS MEET ALL APPLICABLE LAWS, REGULATIONS, AND PROJECT REQUIREMENTS.

INSERTA TEE DETAIL

NTS

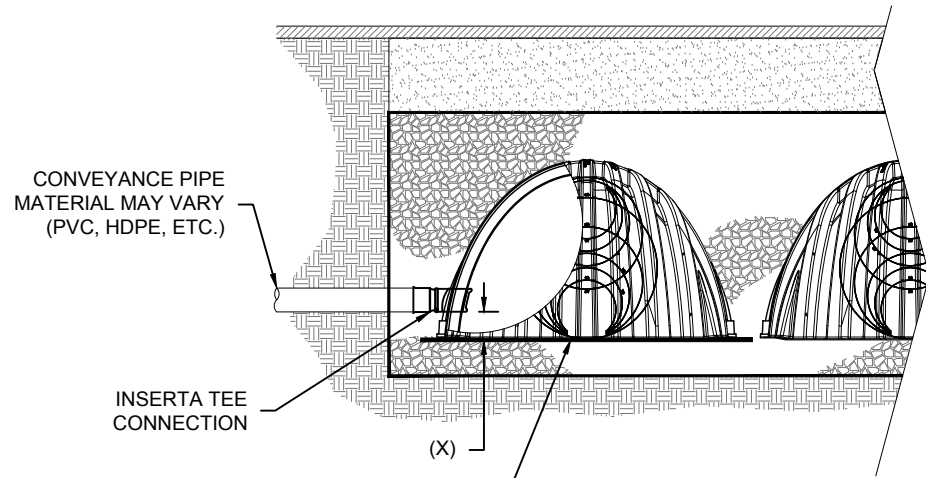

PLACE ADS GEOSYNTHETICS 315 WOVEN GEOTEXTILE (CENTERED ON INSERTA-TEE INLET) OVER BEDDING STONE FOR SCOUR PROTECTION AT SIDE INLET CONNECTIONS. GEOTEXTILE MUST EXTEND 6" (150 mm) PAST CHAMBER FOOT

SECTION A-A

DO NOT INSTALL INSERTA-TEE AT CHAMBER JOINTS

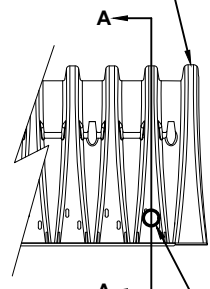

INSERTA TEE TO BE INSTALLED, CENTERED OVER CORRUGATION

SIDE VIEW

CHAMBER	MAX DIAMETER OF INSERTA TEE	HEIGHT FROM BASE OF CHAMBER (X)
SC-310	6" (150 mm)	4" (100 mm)
SC-740	10" (250 mm)	4" (100 mm)
DC-780	10" (250 mm)	4" (100 mm)
MC-3500	12" (300 mm)	6" (150 mm)
MC-4500	12" (300 mm)	8" (200 mm)

INSERTA TEE FITTINGS AVAILABLE FOR SDR 26, SDR 35, SCH 40 IPS GASKETED & SOLVENT WELD, N-12, HP STORM, C-900 OR DUCTILE IRON

NOTE: PART NUMBERS WILL VARY BASED ON INLET PIPE MATERIALS. CONTACT STORMTECH FOR MORE INFORMATION.

MC-3500 TECHNICAL SPECIFICATION

NTS

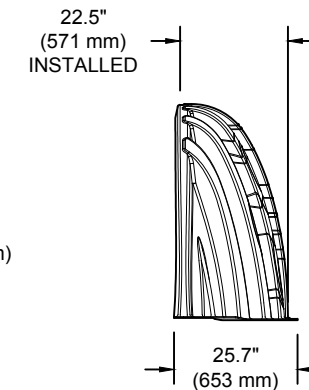
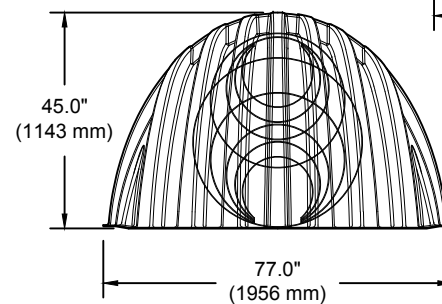
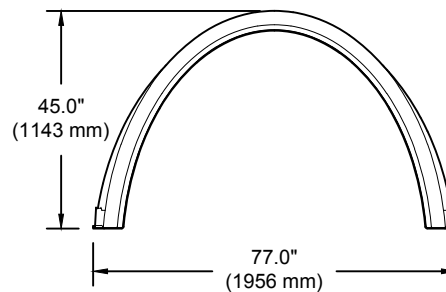
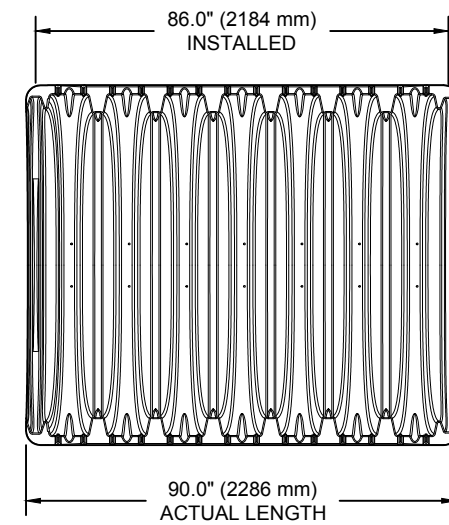
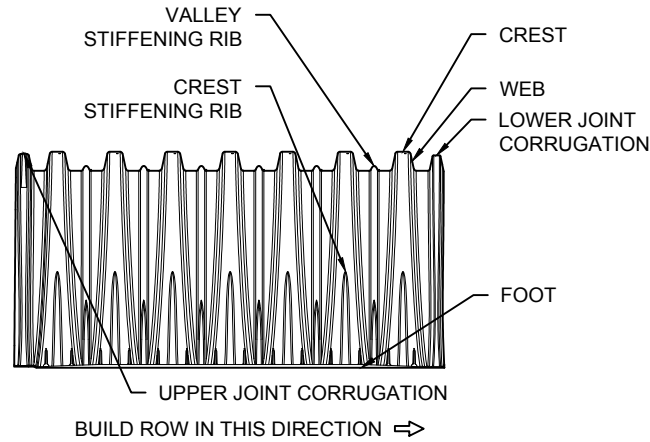

NOMINAL CHAMBER SPECIFICATIONS

SIZE (W X H X INSTALLED LENGTH) 77.0" X 45.0" X 86.0" (1956 mm X 1143 mm X 2184 mm)
 CHAMBER STORAGE 109.9 CUBIC FEET (3.11 m³)
 MINIMUM INSTALLED STORAGE* 178.9 CUBIC FEET (5.06 m³)
 WEIGHT 135.0 lbs. (61.2 kg)

NOMINAL END CAP SPECIFICATIONS

SIZE (W X H X INSTALLED LENGTH) 77.0" X 45.0" X 22.5" (1956 mm X 1143 mm X 571 mm)
 END CAP STORAGE 14.9 CUBIC FEET (0.42 m³)
 MINIMUM INSTALLED STORAGE* 46.0 CUBIC FEET (1.30 m³)
 WEIGHT 50.0 lbs. (22.7 kg)

*ASSUMES 12" (305 mm) STONE ABOVE, 9" (229 mm) STONE FOUNDATION AND BETWEEN CHAMBERS, 12" (305 mm) STONE PERIMETER IN FRONT OF END CAPS AND 40% STONE POROSITY

STUBS AT BOTTOM OF END CAP FOR PART NUMBERS ENDING WITH "B"
 STUBS AT TOP OF END CAP FOR PART NUMBERS ENDING WITH "T"

PART #	STUB	B	C
MC3500IEPP06T	6" (150 mm)	33.21" (844 mm)	---
MC3500IEPP06B	---	---	0.66" (17 mm)
MC3500IEPP08T	8" (200 mm)	31.16" (791 mm)	---
MC3500IEPP08B	---	---	0.81" (21 mm)
MC3500IEPP10T	10" (250 mm)	29.04" (738 mm)	---
MC3500IEPP10B	---	---	0.93" (24 mm)
MC3500IEPP12T	12" (300 mm)	26.36" (670 mm)	---
MC3500IEPP12B	---	---	1.35" (34 mm)
MC3500IEPP15T	15" (375 mm)	23.39" (594 mm)	---
MC3500IEPP15B	---	---	1.50" (38 mm)
MC3500IEPP18TC	18" (450 mm)	20.03" (509 mm)	---
MC3500IEPP18BC	---	---	1.77" (45 mm)
MC3500IEPP24TC	24" (600 mm)	14.48" (368 mm)	---
MC3500IEPP24BC	---	---	2.06" (52 mm)
MC3500IEPP30BC	30" (750 mm)	---	---

NOTE: ALL DIMENSIONS ARE NOMINAL

CUSTOM PRECURED INVERTS ARE AVAILABLE UPON REQUEST. INVENTORIED MANIFOLDS INCLUDE 12-24" (300-600 mm) SIZE ON SIZE AND 15-48" (375-1200 mm) ECCENTRIC MANIFOLDS. CUSTOM INVERT LOCATIONS ON THE MC-3500 END CAP CUT IN THE FIELD ARE NOT RECOMMENDED FOR PIPE SIZES GREATER THAN 10" (250 mm) THE INVERT LOCATION IN COLUMN 'B' ARE THE HIGHEST POSSIBLE FOR THE PIPE SIZE.

MC-SERIES END CAP INSERTION DETAIL

NTS

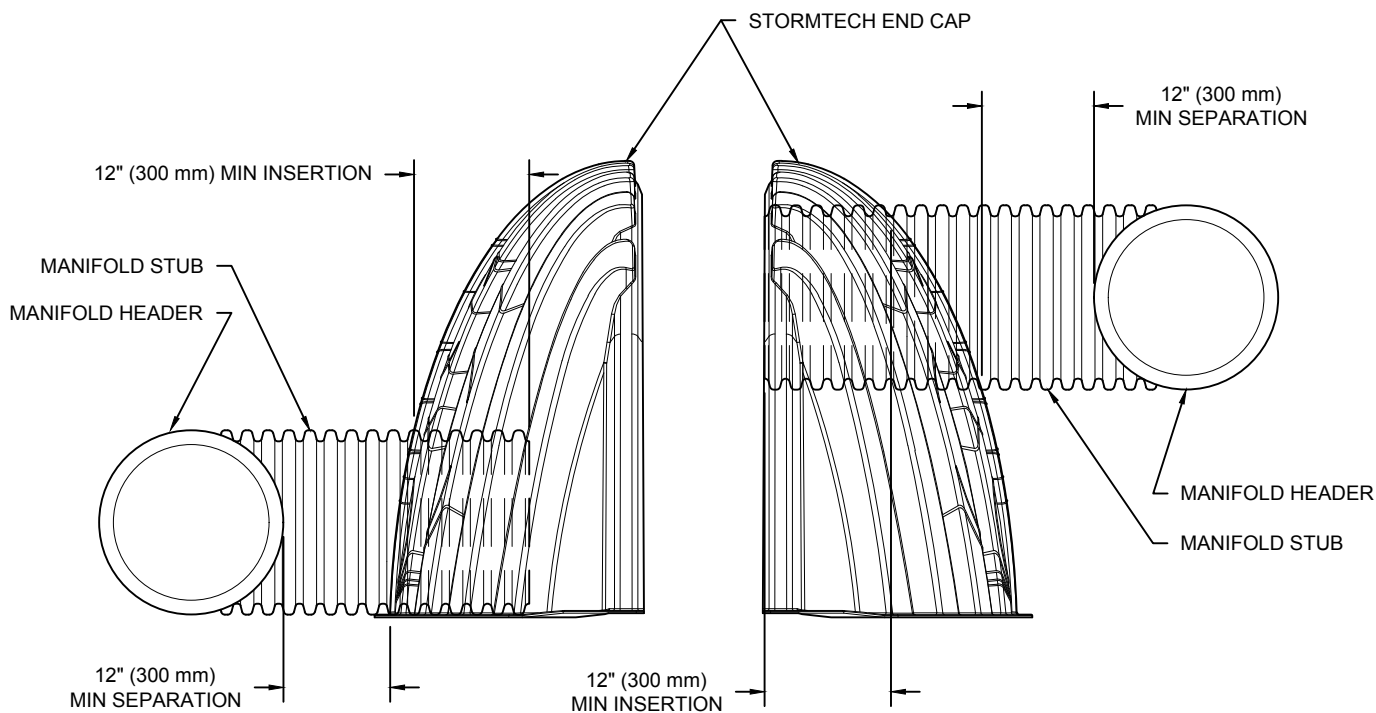

NOTE: MANIFOLD STUB MUST BE LAID HORIZONTAL FOR A PROPER FIT IN END CAP OPENING.

2465070 ONTARIO LTD
 2375 ST-LAURENT BLVD., OTTAWA,
 DATE: 12/06/2017 DRAWN: GC
 PROJECT #: Tool CHECKED: ---

DESCRIPTION
 CHK
 DRW
 REV

StormTech
 Detention/Retention/Water Quality
 70 INWOOD ROAD, SUITE 3 | ROCKY HILL | CT | 06067
 860-525-8188 | 888-892-2694 | WWW.STORMTECH.COM

4640 TRUJEMAN BLVD
 HILLIARD, OH 43026
 1-800-733-7473
ADS
 ADVANCED DRAINAGE SYSTEMS, INC.

THIS DRAWING HAS BEEN PREPARED BASED ON INFORMATION PROVIDED TO ADS UNDER THE DIRECTION OF THE SITE DESIGN ENGINEER OR OTHER PROJECT REPRESENTATIVE. THE SITE DESIGN ENGINEER SHALL REVIEW THIS DRAWING PRIOR TO CONSTRUCTION. IT IS THE ULTIMATE RESPONSIBILITY OF THE SITE DESIGN ENGINEER TO ENSURE THAT THE PRODUCT(S) DEPICTED AND ALL ASSOCIATED DETAILS MEET ALL APPLICABLE LAWS, REGULATIONS, AND PROJECT REQUIREMENTS.

SHEET
 5 OF 5

APPENDIX F
Stormceptor Reports

Brief Stormceptor Sizing Report - 2465070 ONTARIO LTD

Project Information & Location			
Project Name	2465070 ONTARIO LTD	Project Number	170721
City	Ottawa	State/ Province	Ontario
Country	Canada	Date	12/7/2017
Designer Information		EOR Information (optional)	
Name	Guillaume Courtois	Name	
Company	LRL Associates Ltd.	Company	
Phone #	613-842-3434	Phone #	
Email	gcourtois@lrl.ca	Email	

Stormwater Treatment Recommendation

The recommended Stormceptor Model(s) which achieve or exceed the user defined water quality objective for each site within the project are listed in the below Sizing Summary table.

Site Name	Proposed Yonaka Warehouse
Target TSS Removal (%)	80
TSS Removal (%) Provided	81
Recommended Stormceptor Model	STC 300

The recommended Stormceptor Model achieves the water quality objectives based on the selected inputs, historical rainfall records and selected particle size distribution.

Stormceptor Sizing Summary	
Stormceptor Model	% TSS Removal Provided
STC 300	81
STC 750	87
STC 1000	88
STC 1500	87
STC 2000	89
STC 3000	90
STC 4000	92
STC 5000	92
STC 6000	93
STC 9000	95
STC 10000	95
STC 14000	96
StormceptorMAX	Custom

Sizing Details			
Drainage Area		Water Quality Objective	
Total Area (ha)	0.659	TSS Removal (%)	80.0
Imperviousness %	83.0	Runoff Volume Capture (%)	
Rainfall		Oil Spill Capture Volume (L)	
Station Name	OTTAWA MACDONALD-CARTIER INT'L A	Peak Conveyed Flow Rate (L/s)	
State/Province	Ontario	Water Quality Flow Rate (L/s)	
Station ID #	6000	Up Stream Storage	
Years of Records	37	Storage (ha-m)	Discharge (cms)
Latitude	45°19'N	0.000	0.000
Longitude	75°40'W	0.022	0.043
		Up Stream Flow Diversion	
		Max. Flow to Stormceptor (cms)	

Particle Size Distribution (PSD) The selected PSD defines TSS removal		
Fine Distribution		
Particle Diameter (microns)	Distribution %	Specific Gravity
20.0	20.0	1.30
60.0	20.0	1.80
150.0	20.0	2.20
400.0	20.0	2.65
2000.0	20.0	2.65

Notes
<ul style="list-style-type: none"> Stormceptor performance estimates are based on simulations using PCSWMM for Stormceptor, which uses the EPA Rainfall and Runoff modules. Design estimates listed are only representative of specific project requirements based on total suspended solids (TSS) removal defined by the selected PSD, and based on stable site conditions only, after construction is completed. For submerged applications or sites specific to spill control, please contact your local Stormceptor representative for further design assistance.

For Stormceptor Specifications and Drawings Please Visit:
<http://www.imbriumsystems.com/technical-specifications>

APPENDIX G
Complete Set of Civil Plans

EROSION AND SEDIMENT CONTROL MEASURES:

**** CONTRACTOR IS RESPONSIBLE FOR ALL INSTALLATION, MONITORING, REPAIR AND REMOVAL OF ALL EROSION AND SEDIMENT CONTROL FEATURES ****

1 PRIOR TO START OF CONSTRUCTION:

- PRIOR TO THE REMOVAL OF ANY VEGETATIVE COVER, MOVING OF SOIL AND CONSTRUCTION
- INSTALL SILT FENCE IMMEDIATELY DOWNSTREAM FROM AREAS TO BE DISTURBED (SEE PLAN FOR LOCATION)
- INSTALL GEOSOCK INSERTS WITH AN OVERLAP IN ALL THE DOWNSTREAM CATCHBASINS AND MANHOLES
- INSTALL SILTSACK FILTERS IN ALL CONCRETE CATCH BASIN STRUCTURES
- INSPECT MEASURES IMMEDIATELY AFTER INSTALLATION.

2 DURING CONSTRUCTION:

- WORK TO BE DONE IN THE VICINITY OF MAJOR WATERWAYS TO BE CARRIED OUT FROM JULY AND SEPTEMBER ONLY.
- MINIMIZE THE EXTENT OF DISTURBED AREAS AND THE DURATION OF EXPOSURE.
- PROTECT DISTURBED AREAS FROM RUNOFF.
- PROVIDE TEMPORARY COVER SUCH AS SEEDING OR MULCHING IF DISTURBED AREA WILL NOT BE REHABILITATED WITHIN 30 DAYS.
- INSPECT SILT FENCES, FILTER CLOTHS AND CATCH BASIN SUMPS WEEKLY AND AFTER EVERY MAJOR STORM EVENT. CLEAN AND REPAIR WHEN NECESSARY.
- PLAN TO BE REVIEWED AND REVISED AS REQUIRED DURING CONSTRUCTION
- EROSION CONTROL FENCING TO BE ALSO INSTALLED AROUND THE BASE OF ALL STOCKPILES
- DO NOT LOCATE TOPSOIL PILES (IF ANY) AND EXCAVATION MATERIAL CLOSER THAN 2.5m FROM ANY PAVED SURFACE OR ONE WHICH IS TO BE PAVED BEFORE THE PILE IS REMOVED. ALL TOPSOIL PILES (IF ANY) ARE TO BE SEEDED IF THEY ARE TO REMAIN ON SITE LONG ENOUGH FOR SEEDS TO GROW (LONGER THAN 30 DAYS).
- CONTROL WIND-BLOWN DUST OFF SITE TO ACCEPTABLE LEVELS BY SEEDING TOPSOIL PILES AND OTHER AREAS TEMPORARILY (PROVIDE WATERING AS REQUIRED)
- ALL EROSION CONTROL MEASURES TO REMAIN IN PLACE UNTIL ALL DISTURBED GROUND SURFACES HAVE BEEN STABILIZED EITHER BY PAVING OR RESTORATION OF VEGETATIVE GROUND COVER.
- NO ALTERNATE METHODS OF EROSION PROTECTION SHALL BE PERMITTED UNLESS APPROVES BY THIS CONSULTING ENGINEER AND THE CITY DEPARTMENT OF PUBLIC WORKS.
- CONTRACTOR RESPONSIBLE FOR CITY ROADWAY AND SIDEWALK TO BE CLEANED OF ALL SEDIMENT FROM VEHICULAR TRACKING ETC. AT THE END OF EACH WORK DAY.
- PROVIDE GRAVEL ENTRANCE WHEREVER EQUIPMENT LEAVES THE SITE TO PREVENT MUD TRACKING ONTO PAVED SURFACES. GRAVEL BED SHALL BE A MINIMUM OF 15m LONG, 4M WIDE AND 0.5m DEEP AND SHALL CONSIST OF COARSE (50mm CRUSHER-RUN LIMESTONE) MATERIAL. MAINTAIN GRAVEL ENTRANCE IN CLEAN CONDITION.
- DURING WET CONDITIONS, TIRES OF ALL VEHICLES/EQUIPMENT LEAVING THE SITE ARE TO BE SCRAPPED.
- ANY MUD/MATERIAL TRACKED ONTO THE ROAD SHALL BE REMOVED IMMEDIATELY BY HAND OR RUBBER TIRE LOADER.
- TAKE ALL NECESSARY STEPS TO PREVENT BUILDING MATERIAL CONSTRUCTION DEBRIS OR WASTE BEING SPILLED OR TRACKED ONTO ADJUTING PROPERTIES OR PUBLIC STREETS DURING CONSTRUCTION AND PROCEED IMMEDIATELY TO CLEAN UP ANY AREAS SO AFFECTED.

3 AFTER CONSTRUCTION:

- PROVIDE PERMANENT COVER CONSISTING OF TOPSOIL AND SEED TO DISTURBED AREAS.
- REMOVE ANY STRAIN BAILE FLOW CHECK DAMS, SILT FENCES AND FILTER CLOTHS ON CATCH BASINS AND MANHOLE COVERS AFTER DISTURBED AREAS HAVE BEEN REHABILITATED AND STABILIZED.
- INSPECT AND CLEAN CATCH BASIN SUMPS AND STORM SEWERS.

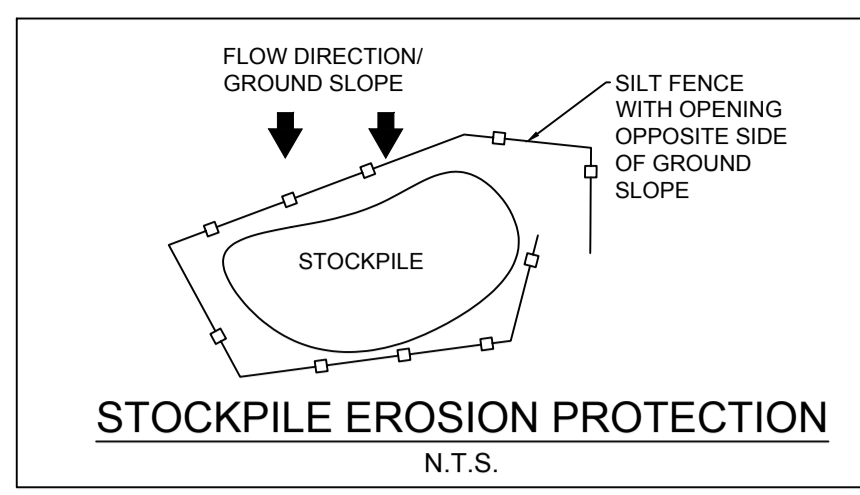
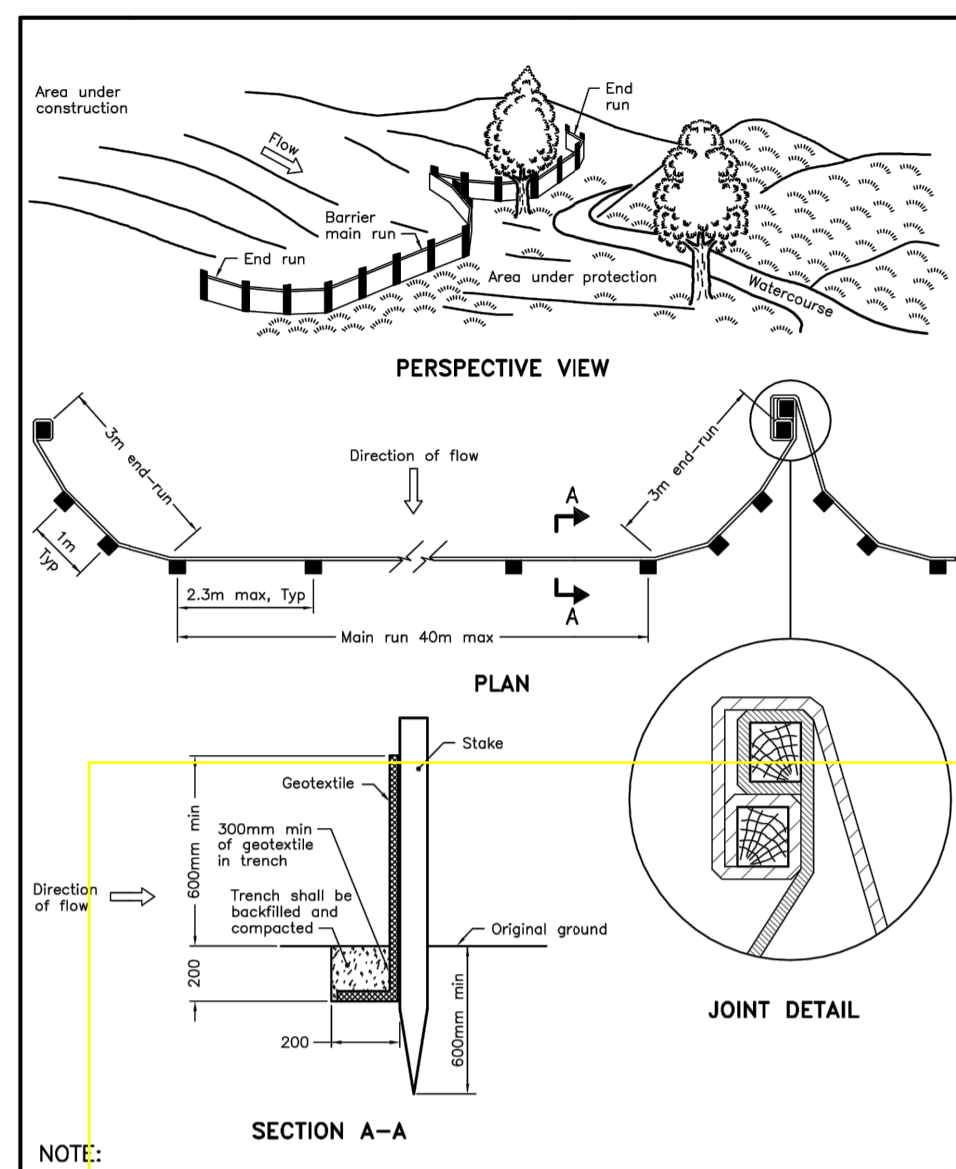

NOTE:
A All dimensions are in millimetres unless otherwise shown.

ONTARIO PROVINCIAL STANDARD DRAWING Nov 2015 Rev 2

LIGHT-DUTY SILT FENCE BARRIER

OPSD 219.110

LEGEND:

- PROPERTY LINE
- PROPOSED CURB
- PROPOSED DEPRESSED CURB
- PROPOSED TERRACING (3:1 MAX. SLOPE)
- PROPOSED DOOR ENTRANCE/EXIT
- EXISTING GRASS AREA TO REMAIN
- PROPOSED CONCRETE FEATURES (SIDEWALK AND LOADING RAMP)
- PROPOSED HEAVY DUTY ASPHALT
- PROPOSED LIGHT DUTY ASPHALT
- ASPHALT TO BE REINSTATED TO MATCH EXISTING CONDITIONS
- 0.3m WIDE (MIN.) STEP JOINT
- PROPOSED SILT FENCE AS PER OPSD 219.110
- PROPOSED ELEVATION
- PROPOSED DEPRESSED CURB ELEVATION
- PROPOSED BOTTOM OF CURB ELEVATION
- PROPOSED TOP OF CURB ELEVATION
- PROPOSED TOP OF GRATE ELEVATION
- MATCH INTO EXISTING ELEVATION
- EXISTING ELEVATION
- PROPOSED OVERLAND MAJOR FLOW ROUTE
- PROPOSED SANITARY SEWER
- PROPOSED STORM SEWER
- PROPOSED WATER SERVICE
- PROPOSED MANHOLE OR STORMSEPTOR
- PROPOSED CATCHBASIN OR CATCHBASIN-MANHOLE
- PROPOSED WATER VALVE
- PROPOSED PIPE REDUCER
- PROPOSED PIPE INSULATION
- PROPOSED 100 YEAR HIGH WATER LEVEL
- STORM WATERSHED EXTENT
- WATERSHED NAME
- RUNOFF COEFFICIENT
- AREA IN HECTARES

GENERAL CONDITIONS OF THE CONTRACT FOR CONSTRUCTION ARE PART OF THE CONTRACT DOCUMENTS AND DESCRIBE THE SCOPE AND INTENT OF THE DRAWING. THE CONTRACT DOCUMENTS INCLUDE NOT ONLY THE DRAWING, BUT ALSO THE OWNER-CONTRACTOR AGREEMENT, THE SPECIFICATIONS, THE ADDENDUMS, THE SPECIFICATIONS, ADDENDA, AND MODIFICATIONS ISSUED AFTER EXECUTION OF THE CONTRACT. THESE CONTRACT DOCUMENTS ARE COMPLEMENTARY, AND WHAT IS REQUIRED BY ANY ONE SHALL BE BINDING AS IF REQUIRED BY ALL. WORK NOT COMPLETELY DELINEATED HEREON SHALL BE CONSIDERED OF THE SAME MATERIAL AND DETAILED SIMILAR AS WORK SHOWN MORE COMPLETELY ELSEWHERE IN THE CONTRACT DOCUMENTS.

BY USE OF THE DRAWINGS FOR CONSTRUCTION OF THE PROJECT, THE OWNER CONFIRMS THAT HE HAS REVIEWED AND APPROVED THE DRAWING. THE CONTRACTOR CONFIRMS THAT HE HAS VISITED THE SITE, FAMILIARIZED HIMSELF WITH THE LOCAL CONDITIONS, VERIFIED FIELD DIMENSIONS AND CORRELATED HIS OBSERVATIONS WITH THE REQUIREMENTS OF THE CONTRACT DOCUMENTS.

UNLESS THE REVISION TITLE IS ISSUED FOR CONSTRUCTION, THESE DRAWINGS SHALL BE CONSIDERED PRELIMINARY AND SHALL NOT BE USED AS A CONSTRUCTION DOCUMENT.

THESE DRAWINGS ILLUSTRATE THE WORK TO BE DONE. THE ENGINEER IS NOT RESPONSIBLE FOR THE MEASUREMENTS, TECHNIQUES, PROCEDURES, AND PROCEDURES USED TO DO THE WORK, OR THE SAFETY ASPECTS OF CONSTRUCTION AND NOTHING ON THESE DRAWINGS EXPRESSED OR IMPLIED CHANGES THIS CONDITION. CONTRACTOR SHALL DETERMINE ALL CONDITIONS AT THE SITE AND SHALL BE RESPONSIBLE FOR KNOWING HOW THEY AFFECT THE WORK. SUBMITTAL OF A BID TO PERFORM THIS WORK IS ACKNOWLEDGEMENT OF THE RESPONSIBILITIES, AND THAT THEY HAVE BEEN FULLY CONSIDERED IN PLANNING OF THE WORK, AND THE BID PRICE. NO CLAIMS FOR EXTRA CHARGES DUE TO THESE CONDITIONS WILL BE FORTHCOMING.

UNAUTHORIZED CHANGES:

IN THE EVENT THE CLIENT, THE CLIENT'S CONTRACTORS OR SUBCONTRACTORS, OR ANYONE FOR WHOM THE CLIENT IS LEGALLY LIABLE MAKES OR PERMITS TO BE MADE ANY CHANGES TO ANY REPORTS, PLANS, SPECIFICATIONS OR OTHER CONSTRUCTION DOCUMENTS PREPARED BY LRL ASSOCIATES LTD. (LRL) WITHOUT OBTAINING LRL'S PRIOR WRITTEN CONSENT, THE CLIENT SHALL ASSUME FULL LIABILITY FOR THE RESULTS OF SUCH CHANGES. THEREFORE THE CLIENT AGREES TO WAIVE ANY CLAIM AGAINST LRL AND TO RELEASE LRL FROM ANY LIABILITY ARISING DIRECTLY OR INDIRECTLY FROM SUCH UNAUTHORIZED CHANGES.

IN ADDITION, THE CLIENT AGREES TO THE FULLEST EXTENT PERMITTED BY LAW, TO INDEMNIFY AND HOLD HARMLESS LRL FROM ANY DAMAGES, LIABILITIES OR COSTS, INCLUDING REASONABLE ATTORNEY'S FEES AND COST OF DEFENSE, ARISING FROM SUCH CHANGES MADE WITHOUT SUCH PROPER AUTHORIZATION.

GENERAL NOTES:

EXISTING SERVICES AND UTILITIES SHOWN ON THESE DRAWINGS ARE TAKEN FROM THE BEST AVAILABLE RECORDS, BUT MAY NOT BE COMPLETE OR TO DATE. CONTRACTOR SHALL VERIFY IN FIELD FOR LOCATION AND ELEVATION OF PIPES AND CHECK WITH THE UTILITY COMPANIES BEFORE DIGGING OR PERFORMING WORK.

CONTRACTOR IS ADVISED TO COLLECT INFORMATION ON SOIL CONDITIONS BEFORE START OF CONSTRUCTION.

THE ENGINEER WAIVES ANY AND ALL RESPONSIBILITY AND LIABILITY FOR PROBLEMS WHICH ARISE FROM FAILURE TO FOLLOW THESE PLANS, SPECIFICATIONS AND THE DESIGN INTENT. THEY CONVEY OR FOR PROBLEMS WHICH ARISE FROM OTHERS' FAILURE TO OBTAIN AND/OR FOLLOW THE ENGINEER'S GUIDANCE WITH RESPECT TO ANY ERRORS, OMISSIONS, INCONSISTENCIES AMBIGUITIES OR CONFLICTS WHICH ARE ALLEGED.

CONTRACTOR TO VERIFY ALL DIMENSIONS AND NOTIFY THE ENGINEER OF ANY DISCREPANCIES BEFORE WORK COMMENCES. DO NOT SCALE DRAWINGS.

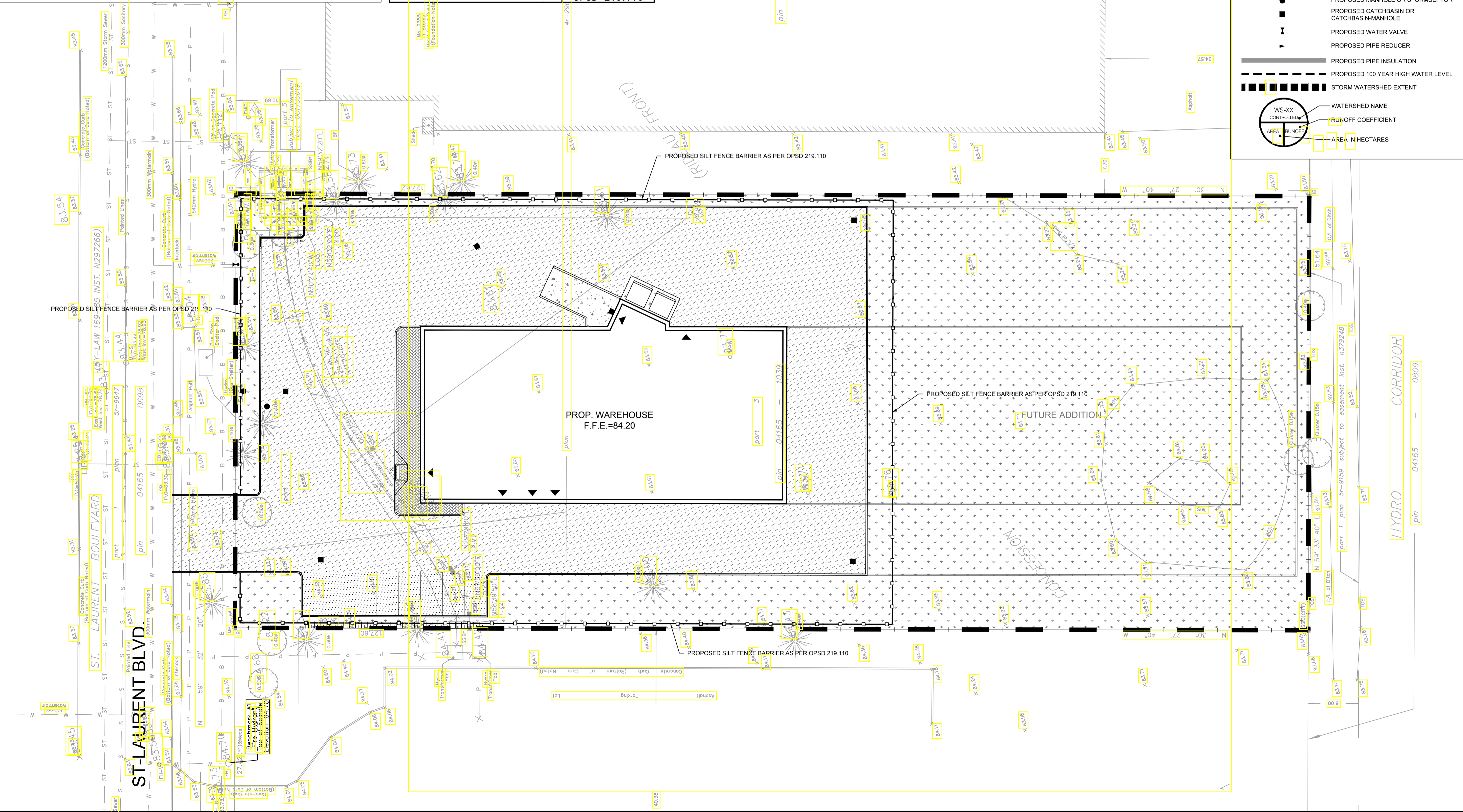

No.	ISSUED FOR SPA	G.M.C.	13 DEC 2017
01	ISSUED FOR SPA	G.M.C.	13 DEC 2017
	REVISIONS	BY	DATE

NOT AUTHENTIC UNLESS SIGNED AND DATED

LRJ
ENGINEERING | INGENIERIE
5430 Canotek Road | Ottawa, ON, K1J 9G2
www.lrl.ca | (613) 842-3434

CLIENT
GRAEBECK CONSTRUCTION LTD.

DESIGNED BY: G.M.C. DRAWN BY: G.M.C. APPROVED BY: J.C.L.

PROJECT
2465070 ONTARIO LTD.
2375 ST-LAURENT BLVD., OTTAWA, ON

DRAWING TITLE
EROSION AND SEDIMENT CONTROL PLAN

PROJECT NO.
170721

DATE
13 DEC 2017

C101

NOTES: GENERAL

- ALL ELEVATIONS ARE GEODETIC AND UTILIZE METRIC UNITS.
- CONFIRM JOB BENCH MARK WITH LRL PRIOR TO UTILIZATION.
- ALL EDGES OF DISTURBED PAVEMENT SHALL BE SAW CUT PRIOR TO PLACING NEW PAVEMENT. PAVEMENT REINSTATEMENT SHALL BE WITH 8 STEP JOINTS OF 300mm WIDTH MINIMUM.
- CURBS TO BE BARRIER, CONSTRUCTED AS PER OPSD 600.110.
- ALL SIDEWALK CONSTRUCTION TO BE AS PER OPSD 310.010 & OPSD 310.050.
- ALL MATERIAL SUPPLIED AND PLACED FOR PARKING LOT AND ACCESS ROAD CONSTRUCTION SHALL BE TO OPSD STANDARDS AND SPECIFICATIONS UNLESS OTHERWISE NOTED. CONSTRUCTION TO OPSD 206, 310 & 314. MATERIALS TO OPSD 100.1, 100.5 & 101.0.
- OBTAIN AND PAY FOR ALL NECESSARY PERMITS AND APPROVALS FROM THE MUNICIPAL AUTHORITIES PRIOR TO COMMENCING CONSTRUCTION, SUCH AS, BUT NOT LIMITED TO: ROAD CUT PERMITS, SEWER PERMITS, WATER PERMIT, ETC. THE APPROVAL OF THIS PLAN DOES NOT EXEMPT THE CONTRACTOR FROM THE REQUIREMENTS TO OBTAIN THE VARIOUS PERMITS/APPROVALS REQUIRED TO COMPLETE THE CONSTRUCTION PROJECT.
- FILTER FABRIC TO BE INSTALLED AND MAINTAINED BETWEEN THE FRAME AND COVER OF ALL CATCHBASINS AND CATCHBASIN MANHOLES DURING THE CONSTRUCTION PERIOD TO MINIMIZE SEDIMENTS ENTERING THE STORM SEWER SYSTEM. ALL GRASSED AREAS MUST BE COMPLETED PRIOR TO THE REMOVAL OF THE FILTER FABRIC IN THE CATCH BASINS.
- REMOVE FROM SITE ALL EXCESS EXCAVATED MATERIAL UNLESS OTHERWISE DIRECTED FROM THE ENGINEER. EXCAVATE AND REMOVE ALL ORGANIC MATERIAL AND DEBRIS, IF ANY, LOCATED WITHIN THE PROPOSED BUILDING, PARKING AND ROADWAY LOCATIONS.
- EXISTING ASPHALT ROADWAY TO BE SAWCUT AND MILLED WHERE ENTRANCE DRIVEWAY IS PROPOSED.

PAVEMENT STRUCTURE

COURSE	MATERIAL	THICKNESS (mm)	
		AUTOMOBILE PARKING	TRUCK ROUTE (HEAVY TRAFFIC)
SURFACE	HL.3 A/C (PG 58-28)	50	40
BINDER	HL.8 A/C (PG 58-28)	-	40
BASECOURSE	GRANULAR "A"	150	150
SUBBASE	GRANULAR "B" TYPE II	300	350

NOTE:
IN PREPARATION FOR PAVEMENT CONSTRUCTION AT THIS SITE, ANY SURFICIAL OR NEAR SURFACE/SUBGRADE LEVEL TOPSOIL AND ANY SOFT, WET OR DELETERIOUS MATERIALS SHOULD BE REMOVED FROM THE PROPOSED PAVED AREAS. THE EXPOSED SUBGRADE SHOULD BE INSPECTED AND APPROVED BY GEOTECHNICAL PERSONNEL AND ANY SOFT AREAS EVIDENT SHOULD BE SUBEXCAVATED AND REPLACED WITH SUITABLE EARTH BORROW APPROVED BY THE GEOTECHNICAL ENGINEER. THE SUBGRADE SHOULD BE SHAPED AND CROWNED TO PROMOTE DRAINAGE OF THE SITE C.B.S. FOLLOWING APPROVAL OF THE PREPARATION OF THE SUBGRADE, THE PAVEMENT GRANULARS MAY BE PLACED.

LEGEND:

- PROPERTY LINE
- PROPOSED CURB
- PROPOSED DEPRESSED CURB
- PROPOSED TERRACING (3:1 MAX. SLOPE)
- PROPOSED DOOR ENTRANCE/EXIT
- EXISTING GRASS AREA TO REMAIN
- PROPOSED CONCRETE FEATURES (SIDEWALK AND LOADING RAMP)
- PROPOSED HEAVY DUTY ASPHALT
- PROPOSED LIGHT DUTY ASPHALT
- ASPHALT TO BE REINSTATED TO MATCH EXISTING CONDITIONS
- 0.3m WIDE (MIN.) STEP JOINT
- PROPOSED ELEVATION
- PROPOSED DEPRESSED CURB ELEVATION
- PROPOSED BOTTOM OF CURB ELEVATION
- PROPOSED TOP OF CURB ELEVATION
- PROPOSED TOP OF GRATE ELEVATION
- MATCH INTO EXISTING ELEVATION
- PROPOSED OVERLAND MAJOR FLOW ROUTE
- SAN PROPOSED SANITARY SEWER
- STM PROPOSED STORM SEWER
- WTR PROPOSED WATER SERVICE
- PROPOSED MANHOLE OR STORMSEPTIC
- PROPOSED CATCHBASIN OR CATCHBASIN-MANHOLE
- PROPOSED WATER VALVE
- PROPOSED PIPE REDUCER
- PROPOSED PIPE INSULATION
- PROPOSED 100 YEAR HIGH WATER LEVEL
- STORM WATERSHED EXTENT
- WATERSHED NAME
- RUNOFF COEFFICIENT
- AREA IN HECTARES

GENERAL CONDITIONS OF THE CONTRACT FOR CONSTRUCTION ARE PART OF THE CONTRACT DOCUMENTS AND DESCRIBE THE SCOPE AND INTENT OF THE DRAWINGS. THE CONTRACTOR SHALL BE RESPONSIBLE FOR OBTAINING ALL NECESSARY PERMITS AND APPROVALS FROM THE MUNICIPAL AUTHORITIES PRIOR TO COMMENCING CONSTRUCTION, SUCH AS, BUT NOT LIMITED TO: ROAD CUT PERMITS, SEWER PERMITS, WATER PERMIT, ETC. THE APPROVAL OF THIS PLAN DOES NOT EXEMPT THE CONTRACTOR FROM THE REQUIREMENTS TO OBTAIN THE VARIOUS PERMITS/APPROVALS REQUIRED TO COMPLETE THE CONSTRUCTION PROJECT.

BY USE OF THE DRAWINGS FOR CONSTRUCTION OF THE PROJECT, THE OWNER CONFIRMS THAT HE HAS REVIEWED AND APPROVED THE DRAWINGS. THE CONTRACTOR CONFIRMS THAT HE HAS VISITED THE SITE, FAMILIARIZED HIMSELF WITH THE LOCAL CONDITIONS, VERIFIED FIELD DIMENSIONS AND CORRELATED HIS OBSERVATIONS WITH THE REQUIREMENTS OF THE CONTRACT DOCUMENTS.

AS INSTRUMENTS OF SERVICE, ALL DRAWINGS, SPECIFICATIONS, CADD FILES OR OTHER ELECTRONIC MEDIA AND COPIES THERE OF FURNISHED BY THE ENGINEER ARE HIS PROPERTY. THEY ARE TO BE USED ONLY FOR THIS PROJECT AND ARE NOT TO BE USED ON ANY OTHER PROJECT, INCLUDING REPEATS OF THE PROJECT. CHANGES TO THE DRAWINGS MAY ONLY BE MADE BY THE ENGINEER.

UNLESS THE REVISION TITLE IS ISSUED FOR CONSTRUCTION, THESE DRAWINGS SHALL BE CONSIDERED PRELIMINARY AND SHALL NOT BE USED AS A CONSTRUCTION DOCUMENT.

THESE DRAWINGS ILLUSTRATE THE WORK TO BE DONE. THE ENGINEER IS NOT RESPONSIBLE FOR THE MEANS, METHODS, TECHNIQUES, SEQUENCES, AND PROCEDURES USED TO DO THE WORK, OR THE SAFETY ASPECTS OF CONSTRUCTION AND NOTHING ON THESE DRAWINGS EXPRESSED OR IMPLIED CHANGES THIS CONDITION. CONTRACTOR SHALL DETERMINE ALL CONDITIONS AT THE SITE AND SHALL BE RESPONSIBLE FOR KNOWING HOW THEY AFFECT THE WORK. SUBMITTAL OF A BID TO PERFORM THIS WORK IS ACKNOWLEDGEMENT OF THE RESPONSIBILITIES, AND THAT THEY HAVE BEEN FULLY CONSIDERED IN PLANNING OF THE WORK, AND THE BID PRICE. NO CLAIMS FOR EXTRA CHARGES DUE TO THESE CONDITIONS WILL BE FORTHCOMING.

UNAUTHORIZED CHANGES:
IN THE EVENT THE CLIENT, THE CLIENT'S CONTRACTORS OR SUBCONTRACTORS, OR ANYONE FOR WHOM THE CLIENT IS LEGALLY LIABLE MAKES OR PERMITS TO BE MADE ANY CHANGES TO ANY REPORTS, PLANS, SPECIFICATIONS OR OTHER CONSTRUCTION DOCUMENTS PREPARED BY LRL ASSOCIATES LTD. (LRL) WITHOUT OBTAINING LRL'S PRIOR WRITTEN CONSENT, THE CLIENT SHALL ASSUME FULL RESPONSIBILITY FOR THE RESULTS OF SUCH CHANGES. THEREFORE THE CLIENT AGREES TO WAIVE ANY CLAIM AGAINST LRL AND TO RELEASE LRL FROM ANY LIABILITY ARISING DIRECTLY OR INDIRECTLY FROM SUCH UNAUTHORIZED CHANGES.

IN ADDITION, THE CLIENT AGREES TO THE FULLEST EXTENT PERMITTED BY LAW, TO INDEMNIFY AND HOLD HARMLESS LRL FROM ANY DAMAGES, LIABILITIES OR COST, INCLUDING REASONABLE ATTORNEY'S FEES AND COST OF DEFENSE, ARISING FROM SUCH CHANGES.

IN ADDITION, THE CLIENT AGREES TO INCLUDE IN ANY CONTRACTS FOR CONSTRUCTION APPROPRIATE LANGUAGE THAT PROHIBITS THE CONTRACTOR OR ANY SUBCONTRACTORS OF ANY TIER FROM MAKING ANY CHANGES OR MODIFICATIONS TO LRL'S CONSTRUCTION DOCUMENTS WITHOUT THE PRIOR WRITTEN APPROVAL OF LRL AND THAT FURTHER REQUIRES THE CONTRACTOR TO INDEMNIFY BOTH LRL AND THE CLIENT FROM ANY LIABILITY OR COST ARISING FROM SUCH CHANGES MADE WITHOUT SUCH PROPER AUTHORIZATION.

GENERAL NOTES:
EXISTING SERVICES AND UTILITIES SHOWN ON THESE DRAWINGS ARE TAKEN FROM THE BEST AVAILABLE RECORDS, BUT MAY NOT BE COMPLETE OR TO DATE. CONTRACTOR SHALL VERIFY IN FIELD FOR LOCATION AND ELEVATION OF PIPES AND CHECK WITH THE UTILITY COMPANIES BEFORE DIGGING OR PERFORMING WORK.

CONTRACTOR IS ADVISED TO COLLECT INFORMATION ON SOIL CONDITIONS BEFORE START OF CONSTRUCTION.

THE ENGINEER WAIVES ANY AND ALL RESPONSIBILITY AND LIABILITY FOR PROBLEMS WHICH ARISE FROM FAILURE TO FOLLOW THESE PLANS, SPECIFICATIONS AND THE DESIGN INTENT THEY CONVEY, OR FOR PROBLEMS WHICH ARISE FROM OTHERS' FAILURE TO OBTAIN AND/OR FOLLOW THE ENGINEER'S GUIDANCE WITH RESPECT TO ANY ERRORS, OMISSIONS, INCONSISTENCIES AMBIGUITIES OR CONFLICTS WHICH ARE ALLEGED.

CONTRACTOR TO VERIFY ALL DIMENSIONS AND NOTIFY THE ENGINEER OF ANY DISCREPANCIES BEFORE WORK COMMENCES. DO NOT SCALE DRAWINGS.

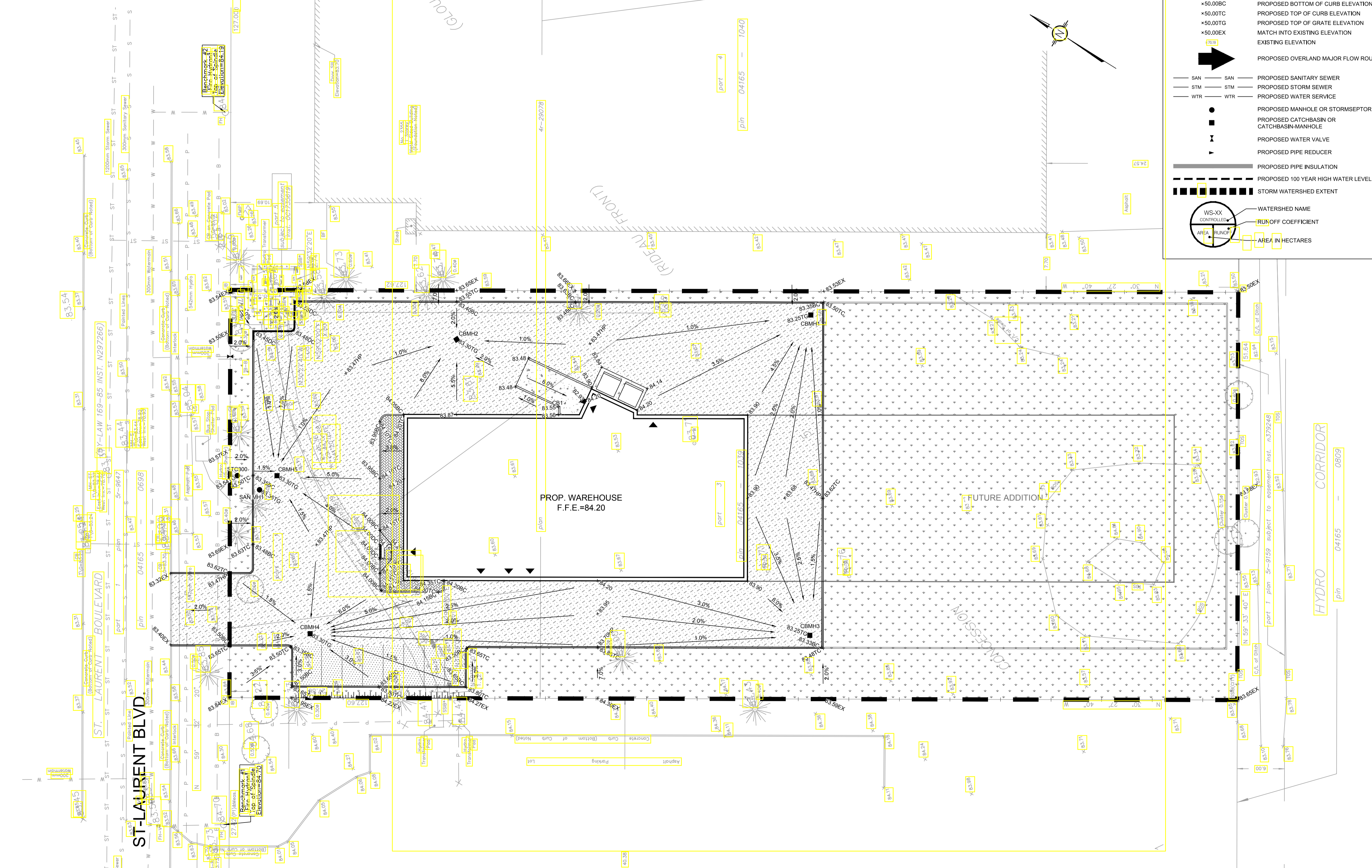
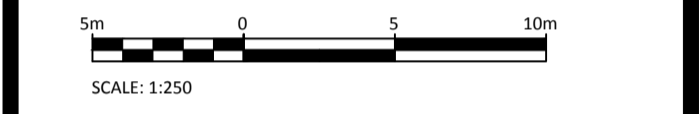

01	ISSUED FOR SPA	G.M.C.	13 DEC 2017
No.	REVISIONS	BY	DATE



NOT AUTHENTIC UNLESS SIGNED AND DATED

LRJ
ENGINEERING | INGÉNIÉRIE
5430 Canotek Road | Ottawa, ON, K1J 9G2
www.lrl.ca | (613) 842-3434

CLIENT
GRAEBECK CONSTRUCTION LTD.

DESIGNED BY: G.M.C. DRAWN BY: G.M.C. APPROVED BY: J.C.L.

PROJECT
**2465070 ONTARIO LTD.
2375 ST-LAURENT BLVD., OTTAWA, ON**

DRAWING TITLE
GRADING AND DRAINAGE PLAN

PROJECT NO.
170721

DATE
13 DEC 2017

C301

NOTES - GENERAL

- ALL EDGES OF DISTURBED PAVEMENT SHALL BE SAW CUT PRIOR TO PLACING NEW PAVEMENT. PAVEMENT REINSTATEMENT SHALL BE WITH STEP JOINTS OF 300mm WIDTH MINIMUM.
- OBTAIN AND PAY FOR ALL NECESSARY PERMITS AND APPROVALS FROM THE MUNICIPAL AUTHORITIES PRIOR TO COMMENCING CONSTRUCTION, SUCH AS, BUT NOT LIMITED TO, ROAD CUT PERMITS, SEWER PERMITS, WATER PERMIT, ETC. THE APPROVAL OF THIS PLAN DOES NOT EXEMPT THE CONTRACTOR FROM THE REQUIREMENTS TO OBTAIN THE VARIOUS PERMITS/APPROVALS REQUIRED TO COMPLETE THE CONSTRUCTION PROJECT.
- FILTER FABRIC TO BE INSTALLED AND MAINTAINED BETWEEN THE FRAME AND COVER OF ALL CATCHBASINS AND CATCHBASIN MANHOLES DURING THE CONSTRUCTION PERIOD TO MINIMIZE SEDIMENTS ENTERING THE STORM SEWER SYSTEM. ALL GRASSED AREAS MUST BE COMPLETED PRIOR TO THE REMOVAL OF THE FILTER FABRIC IN THE CATCH BASINS.
- REMOVE FROM SITE ALL EXCESS EXCAVATED MATERIAL UNLESS OTHERWISE DIRECTED FROM THE ENGINEER. EXCAVATE AND REMOVE ALL ORGANIC MATERIAL AND DEBRIS, IF ANY, LOCATED WITHIN THE PROPOSED BUILDING, PARKING AND ROADWAY LOCATIONS.
- AT PROPOSED CONNECTION POINTS AND CROSSINGS (I.E. STORM, SANITARY, WATERMAIN, HYDRO, BELL, ETC.) THE CONTRACTOR SHALL DETERMINE THE PRECISE LOCATION AND DEPTH OF EXISTING UTILITIES AND REPORT ANY DISCREPANCIES OR CONFLICTS TO THE ENGINEER BEFORE COMMENCING WORK.

NOTES - SEWER

- SEWER BEDDING AS PER PIPE TRENCH DETAIL WITH GRANULAR 'A' BEDDING COMPACTED TO 95% OF ITS SPMD.
- ALL WORK SHALL BE PERFORMED, AS APPLICABLE IN ACCORDANCE WITH OPSS 407, AND 410.
- CONTRACTOR TO CONFIRM ELEVATION OF EXISTING SEWERS AT PROPOSED CONNECTION POINTS AND REPORT ANY DISCREPANCIES TO THE ENGINEER BEFORE COMMENCING ANY WORK.
- ALL SEWERS WITH LESS THAN 2.0m OF COVER ARE SUBJECT TO THE INSULATION DETAIL ON PLAN C901.

LEGEND:

GENERAL CONDITIONS OF THE CONTRACT FOR CONSTRUCTION ARE PART OF THE CONTRACT DOCUMENTS AND DESCRIBE THE SCOPE AND INTENT OF THE DRAWING. THE CONTRACT DOCUMENTS INCLUDE NOT ONLY THE DRAWING, BUT ALSO THE OWNER/CONTRACTOR AGREEMENT, CONDITIONS OF THE CONTRACT, THE SPECIFICATIONS, ADDENDA, AND MODIFICATIONS ISSUED AFTER EXECUTION OF THE CONTRACT. THESE CONTRACT DOCUMENTS ARE COMPLEMENTARY, AND WHAT IS REQUIRED BY ANY ONE SHALL BE BINDING AS IF REQUIRED BY ALL WORK NOT COMPLETELY DELINEATED HEREON SHALL BE CONSIDERED OF THE SAME MATERIAL AND DETAIL UNLESS SHOWN MORE COMPLETELY ELSEWHERE IN THE CONTRACT DOCUMENTS.

BY USE OF THE DRAWINGS FOR CONSTRUCTION OF THE PROJECT, THE OWNER CONFIRMS THAT HE HAS REVIEWED AND APPROVED THE DRAWINGS. THE CONTRACTOR CONFIRMS THAT HE HAS VISITED THE SITE, FAMILIARIZED HIMSELF WITH THE LOCAL CONDITIONS, VERIFIED FIELD DIMENSIONS AND CORRELATED HIS OBSERVATIONS WITH THE REQUIREMENTS OF THE CONTRACT DOCUMENTS.

AS INSTRUMENTS OF SERVICE, ALL DRAWINGS, SPECIFICATIONS, CADD FILES OR OTHER ELECTRONIC MEDIA AND COPIES THERE OF FURNISHED BY THE ENGINEER ARE HIS PROPERTY. THEY ARE TO BE USED ONLY FOR THIS PROJECT AND ARE NOT TO BE USED ON ANY OTHER PROJECT, INCLUDING REPEATS OF THE PROJECT. CHANGES TO THE DRAWINGS MAY ONLY BE MADE BY THE ENGINEER.

UNLESS THE REVISION TITLE IS ISSUED FOR CONSTRUCTION, THESE DRAWINGS SHALL BE CONSIDERED PRELIMINARY AND SHALL NOT BE USED AS A CONSTRUCTION DOCUMENT.

THESE DRAWINGS ILLUSTRATE THE WORK TO BE DONE. THE ENGINEER IS NOT RESPONSIBLE FOR THE MEANS, METHODS, TECHNIQUES, SEQUENCES, AND PROCEDURES USED TO DO THE WORK, OR THE SAFETY ASPECTS OF CONSTRUCTION AND NOTHING ON THESE DRAWINGS EXPRESSED OR IMPLIED CHANGES THIS CONDITION. CONTRACTOR SHALL DETERMINE ALL CONDITIONS AT THE SITE AND SHALL BE RESPONSIBLE FOR KNOWING HOW THEY AFFECT THE WORK. SUBMITTAL OF A BID TO PERFORM THIS WORK IS AN ACKNOWLEDGMENT OF THE RESPONSIBILITIES, AND THAT THEY HAVE BEEN FULLY CONSIDERED IN PLANNING OF THE WORK, AND THE BID PRICE. NO CLAIMS FOR EXTRA CHARGES DUE TO THESE CONDITIONS WILL BE FORTHCOMING.

UNAUTHORIZED CHANGES:

IN THE EVENT THE CLIENT, THE CLIENT'S CONTRACTORS OR SUBCONTRACTORS, OR ANYONE FOR WHOM THE CLIENT IS LEGALLY LIABLE MAKES OR PERMITS TO BE MADE ANY CHANGES TO ANY REPORTS, PLANS, SPECIFICATIONS OR OTHER CONSTRUCTION DOCUMENTS PREPARED BY LRL ASSOCIATES LTD. (LRL) WITHOUT OBTAINING LRL'S PRIOR WRITTEN CONSENT, THE CLIENT SHALL ASSUME FULL RESPONSIBILITY FOR THE RESULTS OF SUCH CHANGES. THEREFORE THE CLIENT AGREES TO WAIVE ANY CLAIM AGAINST LRL AND TO RELEASE LRL FROM ANY LIABILITY ARISING DIRECTLY OR INDIRECTLY FROM SUCH UNAUTHORIZED CHANGES.

IN ADDITION, THE CLIENT AGREES TO INCLUDE IN ANY CONTRACTS FOR CONSTRUCTION APPROPRIATE LANGUAGE THAT PROHIBITS THE CONTRACTOR OR ANY SUBCONTRACTORS OF ANY TIER FROM MAKING ANY CHANGES OR MODIFICATIONS TO LRL'S CONSTRUCTION DOCUMENTS WITHOUT THE PRIOR WRITTEN APPROVAL OF LRL AND THAT FURTHER REQUIRES THE CONTRACTOR TO INDIcate BOTH LRL AND THE CLIENT FROM ANY LIABILITY OR COST ARISING FROM SUCH CHANGES MADE WITHOUT SUCH PROPER AUTHORIZATION.

GENERAL NOTES:

EXISTING SERVICES AND UTILITIES SHOWN ON THESE DRAWINGS ARE TAKEN FROM THE BEST AVAILABLE RECORDS, BUT MAY NOT BE COMPLETE OR TO DATE. CONTRACTOR SHALL VERIFY IN FIELD FOR LOCATION AND ELEVATION OF PIPES AND CHECK WITH THE UTILITY COMPANIES BEFORE DIGGING OR PERFORMING WORK.

CONTRACTOR IS ADVISED TO COLLECT INFORMATION ON SOIL CONDITIONS BEFORE START OF CONSTRUCTION.

THE ENGINEER WAIVES ANY AND ALL RESPONSIBILITY AND LIABILITY FOR PROBLEMS WHICH ARISE FROM FAILURE TO FOLLOW THESE PLANS, SPECIFICATIONS AND THE DESIGN INTENT. THE CONTRACTOR SHALL FOLLOW THE ENGINEER'S GUIDANCE WITH RESPECT TO ANY ERRORS, OMISSIONS, INCONSISTENCIES AMBIGUITIES OR CONFLICTS WHICH ARE ALLEGED.

CONTRACTOR TO VERIFY ALL DIMENSIONS AND NOTIFY THE ENGINEER OF ANY DISCREPANCIES BEFORE WORK COMMENCES. DO NOT SCALE DRAWINGS.

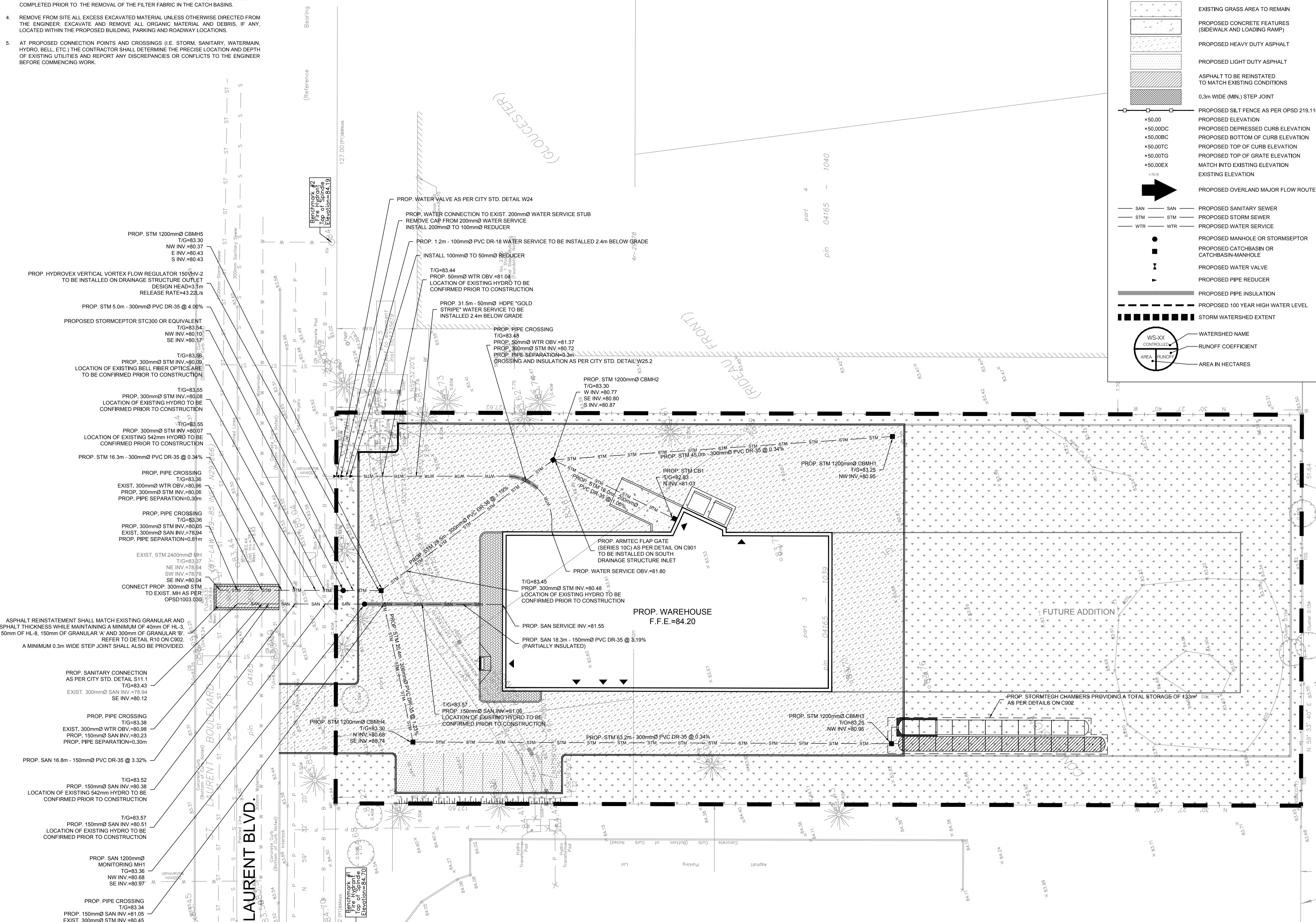

No.	ISSUED FOR SPA	G.M.C.	13 DEC 2017
	REVISIONS	BY	DATE

NOT AUTHENTIC UNLESS SIGNED AND DATED

LRJ
ENGINEERING & INGÉNIERIE
5430 Canotek Road | Ottawa, ON, K1J 9G2
www.lrl.ca | (613) 842-3434

CLIENT
GRAEBECK CONSTRUCTION LTD.

DESIGNED BY: G.M.C. DRAWN BY: G.M.C. APPROVED BY: J.C.L.

PROJECT
2465070 ONTARIO LTD.
2375 ST-LAURENT BLVD., OTTAWA, ON

DRAWING TITLE
SERVICING PLAN

PROJECT NO.
170721

DATE
13 DEC 2017

C401

LEGEND:

- PROPERTY LINE
- PROPOSED CURB
- PROPOSED DEPRESSED CURB
- PROPOSED TERRACING (3:1 MAX. SLOPE)
- PROPOSED DOOR ENTRANCE/EXIT
- EXISTING GRASS AREA TO REMAIN
- PROPOSED CONCRETE FEATURES (SIDEWALK AND LOADING RAMP)
- PROPOSED HEAVY DUTY ASPHALT
- PROPOSED LIGHT DUTY ASPHALT
- ASPHALT TO BE REINSTATED TO MATCH EXISTING CONDITIONS
- 0.3m WIDE (MIN.) STEP JOINT
- PROPOSED SILT FENCE AS PER OPSD 219.110
- PROPOSED ELEVATION
- PROPOSED DEPRESSED CURB ELEVATION
- PROPOSED BOTTOM OF CURB ELEVATION
- PROPOSED TOP OF CURB ELEVATION
- PROPOSED TOP OF GRATE ELEVATION
- MATCH INTO EXISTING ELEVATION
- EXISTING ELEVATION
- PROPOSED OVERLAND MAJOR FLOW ROUTE
- SAN SAN PROPOSED SANITARY SEWER
- STM STM PROPOSED STORM SEWER
- WTR WTR PROPOSED WATER SERVICE
- PROPOSED MANHOLE OR STORMSEPTOR
- PROPOSED CATCHBASIN OR CATCHBASIN-MANHOLE
- PROPOSED WATER VALVE
- PROPOSED PIPE REDUCER
- PROPOSED PIPE INSULATION
- PROPOSED 100 YEAR HIGH WATER LEVEL
- STORM WATERSHED EXTENT
- W5-XX CONTROLLED WATERSHED NAME
- AREA RUNOFF RUNOFF COEFFICIENT
- AREA IN HECTARES

GENERAL CONDITIONS OF THE CONTRACT FOR CONSTRUCTION ARE PART OF THE CONTRACT DOCUMENTS AND DESCRIBE THE SCOPE AND INTENT OF THE DRAWING. THE CONTRACT DOCUMENTS INCLUDE NOT ONLY THE DRAWING, BUT ALSO THE OWNER-CONTRACTOR AGREEMENT, SPECIFICATIONS, ADDENDA, AND MODIFICATIONS ISSUED AFTER EXECUTION OF THE CONTRACT. THESE CONTRACT DOCUMENTS ARE COMPLEMENTARY, AND WHAT IS REQUIRED BY ANY ONE SHALL BE BINDING AS IF REQUIRED BY ALL. WORK NOT COMPLETELY DELINEATED HEREON SHALL BE CONSTRUCTED OF THE SAME MATERIALS AND DETAIL SHOWN AS WORK SHOWN MORE COMPLETELY ELSEWHERE IN THE CONTRACT DOCUMENTS.

BY USE OF THE DRAWINGS FOR CONSTRUCTION OF THE PROJECT, THE OWNER CONFIRMS THAT HE HAS REVIEWED AND APPROVED THE DRAWINGS. THE CONTRACTOR CONFIRMS THAT HE HAS VISITED THE SITE, FAMILIARIZED HIMSELF WITH THE LOCAL CONDITIONS, VERIFIED FIELD DIMENSIONS AND CORRELATED HIS OBSERVATIONS WITH THE REQUIREMENTS OF THE CONTRACT DOCUMENTS.

AS INSTRUMENTS OF SERVICE, ALL DRAWINGS, SPECIFICATIONS, CADD FILES OR OTHER ELECTRONIC MEDIA AND COPIES THERE OF FURNISHED BY THE ENGINEER ARE HIS PROPERTY. THEY ARE TO BE USED ONLY FOR THIS PROJECT AND ARE NOT TO BE USED ON ANY OTHER PROJECT, INCLUDING REPEATS OF THE PROJECT. CHANGES TO THE DRAWINGS MAY ONLY BE MADE BY THE ENGINEER.

UNLESS THE REVISION TITLE IS ISSUED FOR CONSTRUCTION, THESE DRAWINGS SHALL BE CONSIDERED PRELIMINARY AND SHALL NOT BE USED AS A CONSTRUCTION DOCUMENT.

THESE DRAWINGS ILLUSTRATE THE WORK TO BE DONE. THE ENGINEER IS NOT RESPONSIBLE FOR THE MEANS, METHODS, TECHNIQUES, SEQUENCES, AND PROCEDURES USED TO DO THE WORK, OR THE SAFETY ASPECTS OF CONSTRUCTION, AND NOTHING ON THESE DRAWINGS EXPRESSED OR IMPLIED CHANGES THIS CONDITION. CONTRACTOR SHALL DETERMINE ALL CONDITIONS AT THE SITE AND SHALL BE RESPONSIBLE FOR KNOWING HOW THEY AFFECT THE WORK. SUBMITTAL OF A BID TO PERFORM THIS WORK IS ACKNOWLEDGEMENT OF THE RESPONSIBILITIES, AND THAT THEY HAVE BEEN FULLY CONSIDERED IN PLANNING OF THE WORK, AND THE BID PRICE. NO CLAIMS FOR EXTRA CHARGES DUE TO THESE CONDITIONS WILL BE FORTHCOMING.

UNAUTHORIZED CHANGES:

IN THE EVENT THE CLIENT, THE CLIENT'S CONTRACTORS OR SUBCONTRACTORS, OR ANYONE FOR WHOM THE CLIENT IS LEGALLY LIABLE MAKES OR PERMITS TO BE MADE ANY CHANGES TO ANY REPORTS, PLANS, SPECIFICATIONS OR OTHER CONSTRUCTION DOCUMENTS PREPARED BY LRL ASSOCIATES LTD. (LRL) WITHOUT OBTAINING LRL'S PRIOR WRITTEN CONSENT, THE CLIENT SHALL ASSUME FULL RESPONSIBILITY FOR THE RESULTS OF SUCH CHANGES. THEREFORE THE CLIENT AGREES TO WAIVE ANY CLAIM AGAINST LRL AND TO RELEASE LRL FROM ANY LIABILITY ARISING DIRECTLY OR INDIRECTLY FROM SUCH UNAUTHORIZED CHANGES.

IN ADDITION, THE CLIENT AGREES TO THE FULLEST EXTENT PERMITTED BY LAW, TO INDEMNIFY AND HOLD HARMLESS LRL FROM ANY DAMAGES, LIABILITIES OR COST, INCLUDING REASONABLE ATTORNEY'S FEES AND COST OF DEFENSE, ARISING FROM SUCH CHANGES MADE WITHOUT SUCH PROPER AUTHORIZATION.

GENERAL NOTES:

EXISTING SERVICES AND UTILITIES SHOWN ON THESE DRAWINGS ARE TAKEN FROM THE BEST AVAILABLE RECORDS, BUT MAY NOT BE COMPLETE OR TO DATE. CONTRACTOR SHALL VERIFY IN FIELD FOR LOCATION AND ELEVATION OF PIPES AND CHECK WITH THE UTILITY COMPANIES BEFORE DIGGING OR PERFORMING WORK.

CONTRACTOR IS ADVISED TO COLLECT INFORMATION ON SOIL CONDITIONS BEFORE START OF CONSTRUCTION.

THE ENGINEER WAIVES ANY AND ALL RESPONSIBILITY AND LIABILITY FOR PROBLEMS WHICH ARISE FROM FAILURE TO FOLLOW THESE PLANS, SPECIFICATIONS AND THE DESIGN INTENT. THE CLIENT OR FOR PROBLEMS WHICH ARISE FROM OTHERS' FAILURE TO OBTAIN AND/OR FOLLOW THE ENGINEER'S GUIDANCE WITH RESPECT TO ANY ERRORS, OMISSIONS, INCONSISTENCIES AMBIGUITIES OR CONFLICTS WHICH ARE ALLEGED.

CONTRACTOR TO VERIFY ALL DIMENSIONS AND NOTIFY THE ENGINEER OF ANY DISCREPANCIES BEFORE WORK COMMENCES. DO NOT SCALE DRAWINGS.

No.	ISSUED FOR SPA	G.M.C.	13 DEC 2017
01	ISSUED FOR SPA	G.M.C.	13 DEC 2017
No.	REVISIONS	BY	DATE

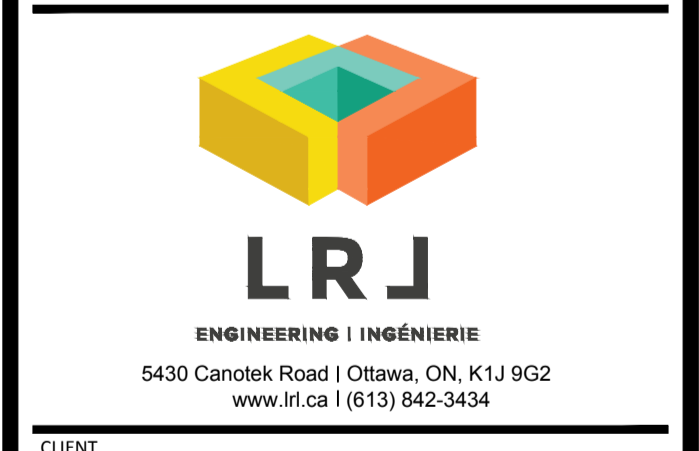
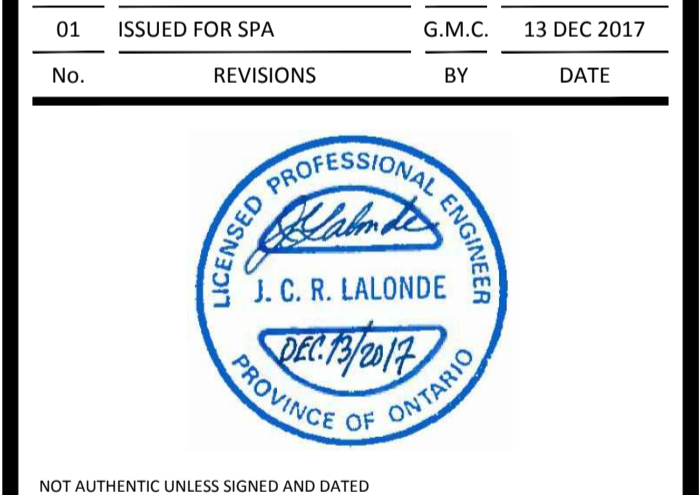

CLIENT
GRAEBECK CONSTRUCTION LTD.

DESIGNED BY: G.M.C. DRAWN BY: G.M.C. APPROVED BY: J.C.L.

PROJECT
**2465070 ONTARIO LTD.
2375 ST-LAURENT BLVD., OTTAWA, ON**

DRAWING TITLE
STORMWATER MANAGEMENT PLAN

PROJECT NO.
170721

DATE
13 DEC 2017

C601

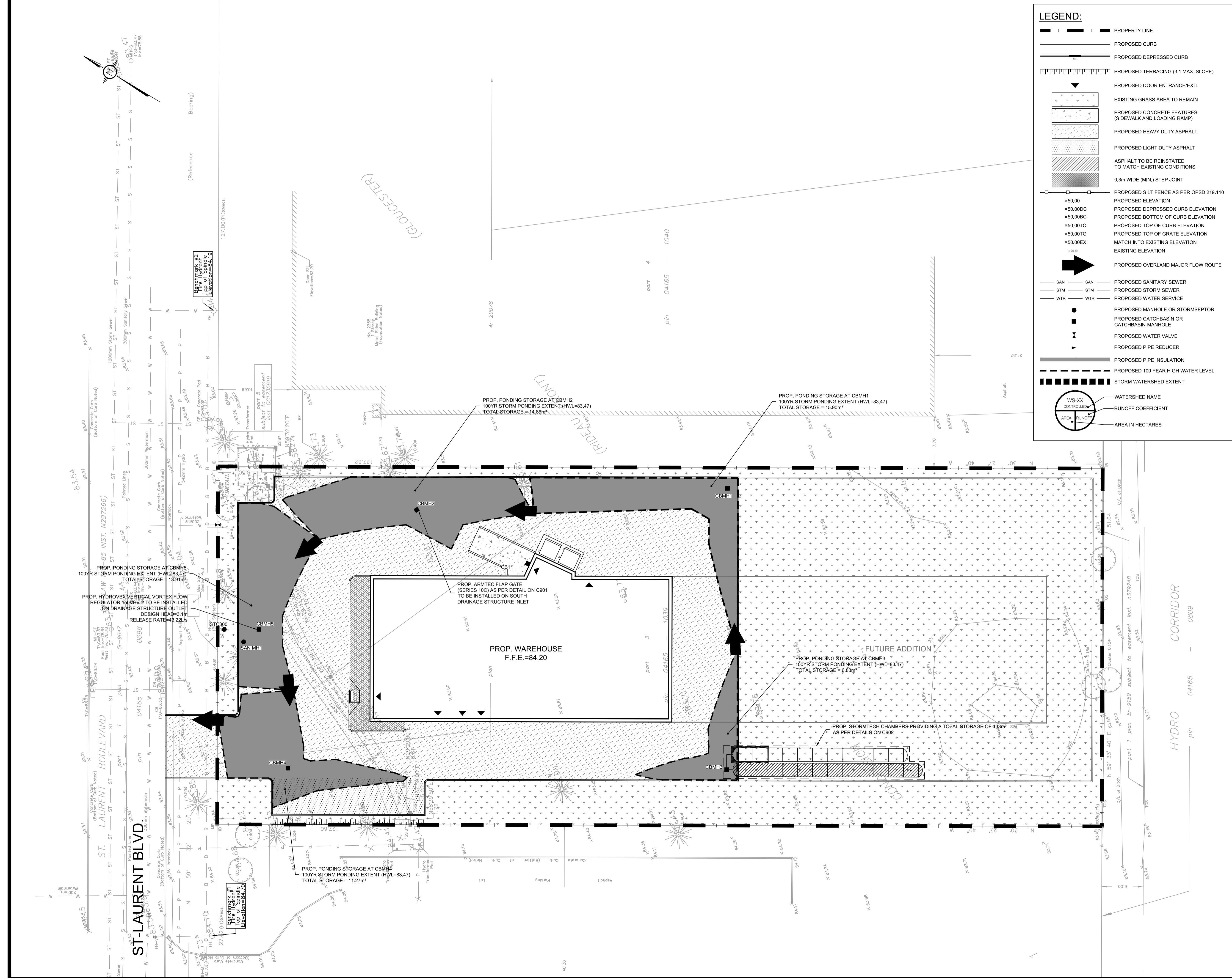

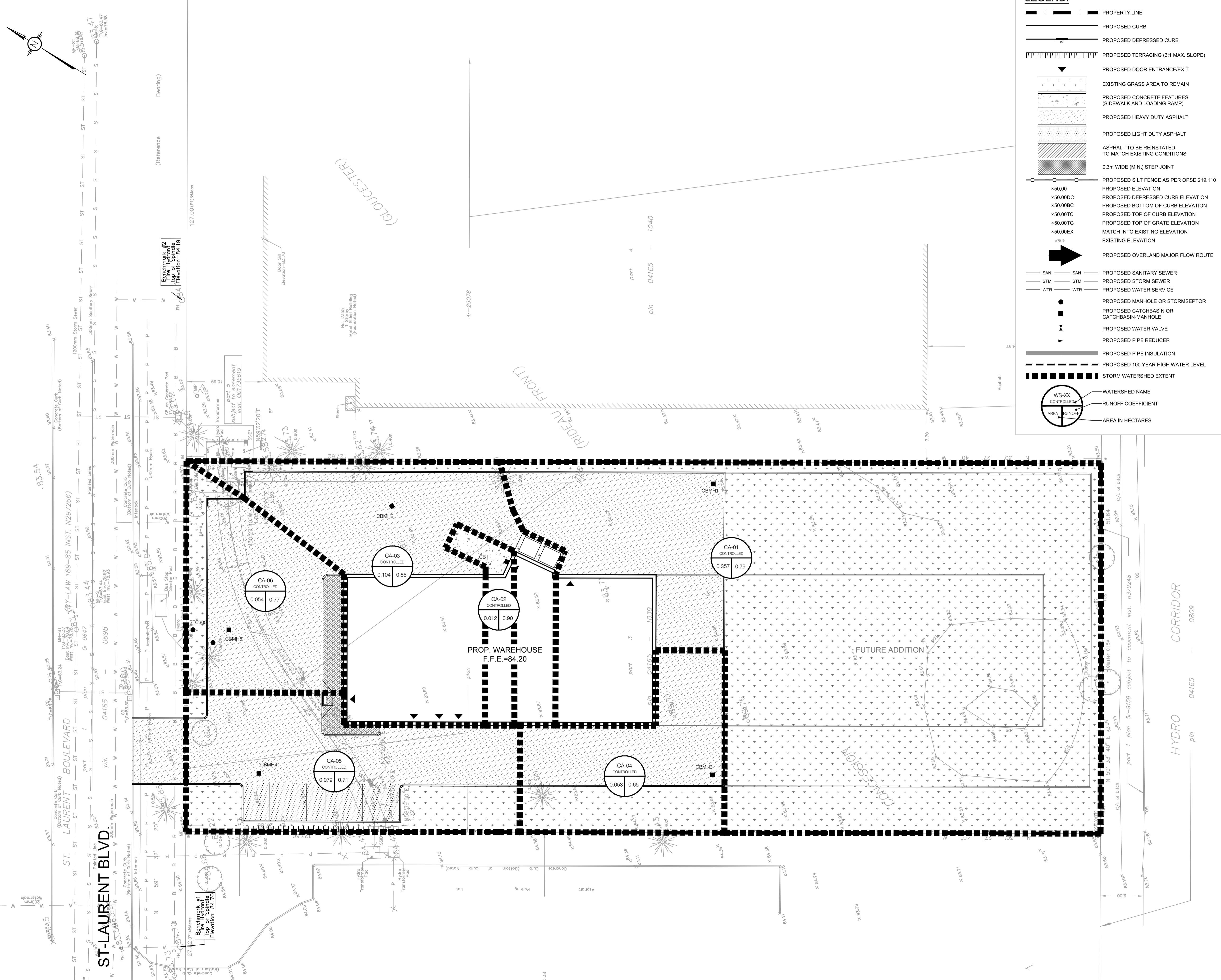

LEGEND:

- — — — — PROPERTY LINE
- ===== PROPOSED CURB
- ===== PROPOSED DEPRESSED CURB
- ===== PROPOSED TERRACING (3:1 MAX. SLOPE)
- ▼ PROPOSED DOOR ENTRANCE/EXIT
- EXISTING GRASS AREA TO REMAIN
- PROPOSED CONCRETE FEATURES (SIDEWALK AND LOADING RAMP)
- PROPOSED HEAVY DUTY ASPHALT
- PROPOSED LIGHT DUTY ASPHALT
- ASPHALT TO BE REINSTATED TO MATCH EXISTING CONDITIONS
- 0.3m WIDE (MIN.) STEP JOINT
- PROPOSED SILT FENCE AS PER OPSD 219.110
- PROPOSED ELEVATION
- PROPOSED DEPRESSED CURB ELEVATION
- PROPOSED BOTTOM OF CURB ELEVATION
- PROPOSED TOP OF CURB ELEVATION
- PROPOSED TOP OF GRATE ELEVATION
- MATCH INTO EXISTING ELEVATION
- EXISTING ELEVATION
- PROPOSED OVERLAND MAJOR FLOW ROUTE
- SAN — SAN — PROPOSED SANITARY SEWER
- STM — STM — PROPOSED STORM SEWER
- WTR — WTR — PROPOSED WATER SERVICE
- PROPOSED MANHOLE OR STORMSEPTOR
- PROPOSED CATCHBASIN OR CATCHBASIN-MANHOLE
- ▼ PROPOSED WATER VALVE
- ▲ PROPOSED PIPE REDUCER
- ===== PROPOSED PIPE INSULATION
- PROPOSED 100 YEAR HIGH WATER LEVEL
- ===== STORM WATERSHED EXTENT
- WS-XX CONTROLLED AREA RUNOFF
- WATERSHED NAME
- RUNOFF COEFFICIENT
- AREA IN HECTARES

GENERAL CONDITIONS OF THE CONTRACT FOR CONSTRUCTION ARE PART OF THE CONTRACT DOCUMENTS AND DESCRIBE THE SCOPE AND INTENT OF THE DRAWING. THE CONTRACTOR SHALL BE RESPONSIBLE FOR OBTAINING ALL NECESSARY PERMITS AND APPROVALS FROM THE LOCAL AUTHORITIES AND FOR OBTAINING ALL NECESSARY INFORMATION FROM THE LOCAL AUTHORITIES AND FOR OBTAINING ALL NECESSARY INFORMATION FROM THE LOCAL AUTHORITIES.

UNAUTHORIZED CHANGES:

IN THE EVENT THE CLIENT, THE CLIENT'S CONTRACTORS OR SUBCONTRACTORS, OR ANYONE FOR WHOM THE CLIENT IS LEGALLY LIABLE MAKES OR PERMITS TO BE MADE ANY CHANGES TO ANY REPORTS, PLANS, SPECIFICATIONS OR OTHER CONSTRUCTION DOCUMENTS PREPARED BY LRL ASSOCIATES LTD. (LRL) WITHOUT OBTAINING LRL'S PRIOR WRITTEN CONSENT, THE CLIENT SHALL ASSUME FULL RESPONSIBILITY FOR THE RESULTS OF SUCH CHANGES. THEREFORE THE CLIENT AGREES TO WAIVE ANY CLAIM AGAINST LRL AND TO RELEASE LRL FROM ANY LIABILITY ARISING DIRECTLY OR INDIRECTLY FROM SUCH UNAUTHORIZED CHANGES.

GENERAL NOTES:

EXISTING SERVICES AND UTILITIES SHOWN ON THESE DRAWINGS ARE TAKEN FROM THE BEST AVAILABLE RECORDS, BUT MAY NOT BE COMPLETE OR TO DATE. CONTRACTOR SHALL VERIFY IN FIELD FOR LOCATION AND ELEVATION OF PIPES AND CHECK WITH THE UTILITY COMPANIES BEFORE DIGGING OR PERFORMING WORK.

CONTRACTOR IS ADVISED TO COLLECT INFORMATION ON SOIL CONDITIONS BEFORE START OF CONSTRUCTION.

THE ENGINEER WAIVES ANY AND ALL RESPONSIBILITY AND LIABILITY FOR PROBLEMS WHICH ARISE FROM FAILURE TO FOLLOW THESE PLANS, SPECIFICATIONS AND THE DESIGN INTENT. THE ENGINEER SHALL NOT BE RESPONSIBLE FOR ANY AND ALL PROBLEMS WHICH ARISE FROM OTHERS' FAILURE TO OBTAIN AND/OR FOLLOW THE ENGINEER'S GUIDANCE WITH RESPECT TO ANY ERRORS, OMISSIONS, INCONSISTENCIES, AMBIGUITIES OR CONFLICTS WHICH ARE ALLEGED.

CONTRACTOR TO VERIFY ALL DIMENSIONS AND NOTIFY THE ENGINEER OF ANY DISCREPANCIES BEFORE WORK COMMENCES. DO NOT SCALE DRAWINGS.

No.	ISSUED FOR SPA	G.M.C.	13 DEC 2017
01	ISSUED FOR SPA	G.M.C.	13 DEC 2017
No.	REVISIONS	BY	DATE

NOT AUTHENTIC UNLESS SIGNED AND DATED

J.C.R. LALONDE
LICENSED PROFESSIONAL ENGINEER
PROVINCE OF ONTARIO

LRJ
ENGINEERING | INGENIERIE
5430 Canotek Road | Ottawa, ON, K1J 9G2
www.lrl.ca | (613) 842-3434

CLIENT
GRAEBECK CONSTRUCTION LTD.

DESIGNED BY: G.M.C. DRAWN BY: G.M.C. APPROVED BY: J.C.L.

PROJECT
2465070 ONTARIO LTD.
2375 ST-LAURENT BLVD., OTTAWA, ON

DRAWING TITLE
POST-DEVELOPMENT WATERSHED PLAN

PROJECT NO.
170721

DATE
13 DEC 2017

C701

STANDARD CIRCULAR FRAME FOR MAINTENANCE HOLES (MODIFIED OPSD-401.020)

DATE: MAY 2001
 SET: MARCH 2008
 DWG No.: S25

NOTES:
 1. MATERIAL: GREY IRON
 2. FOR MAINTENANCE HOLE COVER SEE Dwg S24, S24.1, S24.2
 3. OPSD 400.001-002/003 ARE ALSO APPLICABLE

HEAVY DUTY "FISH" TYPE ROUND CATCH BASIN COVER (MODIFIED OPSD-400.07)

DATE: MAY 2005
 SET: MARCH 2007
 DWG No.: S19

NOTES:
 1. ALL DIMENSIONS SHOWN ARE FOR FORMED CASTINGS ONLY. PATTERN MAKERS AND CASTING SHOP SHOULD MAKE ALLOWANCES ACCORDINGLY.
 2. ALL DIMENSIONS ARE IN MILLIMETRES UNLESS SHOWN OTHERWISE.
 3. FOR NEW CONSTRUCTION WHERE SURFACE INLETS ARE SPECIFIED.
 4. COMPANES WITH GRATE DIMENSIONS NOT EXACTLY THE SAME AS SHOWN ABOVE WILL ALSO BE CONSIDERED.
 5. ALTERNATE SOLID COVER TO HAVE EYE 25mm DIA. HOLE WITH 25mm APPROVED PLUG

STANDARD CIRCULAR SANITARY & COMBINED MAINTENANCE HOLE COVER

DATE: MARCH 2008
 SET: MARCH 2017
 DWG No.: S24

NOTES:
 1. FIN TO BE SET
 2. FOR FRAME DETAILS SEE Dwg No. S25
 3. ALL DIMENSIONS ARE IN MILLIMETRES UNLESS OTHERWISE SHOWN

PRECAST CONCRETE MAINTENANCE HOLE 1200mm DIAMETER

DATE: NOV 2009
 SET: MARCH 2010
 DWG No.: OPSD 701.010

NOTES:
 1. The sump is measured from the lowest invert.
 2. Granular backfill shall be placed to a minimum thickness of 300mm all around the maintenance hole.
 3. Precast concrete components shall be according to OPSD 701.030, 701.031, and 701.032.
 4. Structure exceeding 5.0m in depth shall include safety platform according to OPSD 708.020.
 5. For benching and pipe opening details, see OPSD 701.021.
 6. For adjustment unit and frame installation, see OPSD 704.010.
 7. All dimensions are nominal.
 8. All dimensions are in millimetres unless otherwise shown.

PRECAST CONCRETE CATCH BASIN 600x600mm

DATE: NOV 2009
 SET: MARCH 2010
 DWG No.: OPSD 705.010

NOTES:
 1. Outlet hole size 525mm diameter maximum.
 2. 200mm diameter knockout to accommodate waterline. Knockout shall be 60mm deep.
 3. All dimensions are nominal.
 4. Granular backfill shall be placed to a minimum thickness of 300mm all around the catch basin.
 5. Frame, grate, and adjustment unit shall be installed according to OPSD 704.010.
 6. Pipe support shall be according to OPSD 708.020.
 7. All dimensions are in millimetres unless otherwise shown.

SEWER SERVICE CONNECTIONS FOR FLEXIBLE MAIN SEWER PIPE (MODIFIED OPSD-1006.020)

DATE: MARCH 2008
 SET: MARCH 2013
 DWG No.: S11.1

NOTES:
 1. ALL DIMENSIONS OF SERVICE CONNECTIONS TO FLEXIBLE MAIN SEWER SHALL BE MADE USING APPROVED TEE OR WYE FITTINGS.
 2. SERVICE PIPES TO BE 150mm OR 200mm DIAMETER TO BE SHOWN FOR NEW REVISIONS UNLESS SPECIFIED OTHERWISE.
 3. APPROVED CONTROLLED SETTLEMENT JOINTS SHALL BE USED FOR SERVICE CONNECTIONS TO MAIN EXCEPT UP TO 10m DEEP, WHERE APPROVED CONNECTIONS TO SERVICE OVER 10m DEEP REQUIRE APPROVED CONTROLLED SETTLEMENT JOINTS.
 4. CAP OR PLUG AT THE PROPERTY LINE SHALL BE RESISTANTLY BRACED TO WITHSTAND TESTING PRESSURE.
 5. ALL DIMENSIONS ARE IN MILLIMETRES UNLESS OTHERWISE SHOWN.

INTERNAL DROP STRUCTURE FOR EXISTING MAINTENANCE HOLES

DATE: NOV 2016
 SET: MARCH 2017
 DWG No.: OPSD 1003.030

NOTES:
 1. At the elbow, a stainless steel strap is required at bottom of bell.
 2. A internal drop structure shall be used on existing maintenance holes 1500mm diameter and larger with a minimum height of 600mm from the inlet pipe invert to the top of benching. The existing benching shall be modified as required.
 3. Drop pipe shall be one size smaller than the incoming sewer with a minimum 150mm diameter and maximum of 375mm diameter. A maximum of 300mm diameter for 1500mm maintenance holes.
 4. Straps shall not be placed within 150mm of any maintenance hole section joint.
 5. All dimensions are in millimetres unless otherwise shown.

Series 10C, 20C, 50C Flow Control Gates

DATE: MARCH 2008
 SET: MARCH 2017
 DWG No.: S24

SIZE	A	B	C	D	Pivot Radius
102	228	114	114	76	152
202	444	228	228	152	304
302	660	342	342	228	456
354	762	381	381	255	510
406	864	430	430	282	564
458	966	479	479	309	618
510	1068	528	528	336	672
562	1170	577	577	363	726
614	1272	626	626	390	780
666	1374	675	675	417	834
718	1476	724	724	444	888
770	1578	773	773	471	942
822	1680	822	822	498	996
874	1782	871	871	525	1050
926	1884	920	920	552	1104
978	1986	969	969	579	1158
1030	2088	1018	1018	606	1212
1082	2190	1067	1067	633	1266
1134	2292	1116	1116	660	1320
1186	2394	1165	1165	687	1374
1238	2496	1214	1214	714	1428
1290	2598	1263	1263	741	1482

VORTEX ICD INSTALLATION

DATE: MARCH 2009
 SET: MARCH 2009
 DWG No.: S4.1

NOTES:
 1. VORTEX ICDs ARE USED TO RESTRICT FLOW BELOW THE 2.0m MINIMUM RESTRICTION.
 2. CURVES ARE AVAILABLE FROM THE MANUFACTURER SEE MS - 22.5 FOR APPROVED PRODUCTS.
 3. 200mm MINIMUM SPACING BETWEEN VORTEX ICDs SHALL BE MAINTAINED UNLESS OTHERWISE SPECIFIED.
 4. ALL DIMENSIONS ARE IN MILLIMETRES UNLESS OTHERWISE SHOWN.

STANDARD TRENCH REINSTATEMENT IN PAVED SURFACE

DATE: MAY 2001
 SET: MARCH 2007
 DWG No.: R10

NOTES:
 1. ALL DIMENSIONS ARE IN MILLIMETRES UNLESS OTHERWISE SHOWN.
 2. TRENCH DEPTH SHALL BE AS SHOWN.
 3. TRENCH DEPTH SHALL BE AS SHOWN UNLESS OTHERWISE SPECIFIED.
 4. TRENCH DEPTH SHALL BE AS SHOWN UNLESS OTHERWISE SPECIFIED.

FLEXIBLE PIPE EMBEDMENT AND BACKFILL EARTH EXCAVATION

DATE: NOV 2010
 SET: MARCH 2011
 DWG No.: OPSD 802.010

NOTES:
 1. Height of fill is measured from the finished surface to top of pipe.
 2. The pipe bed shall be compacted and shaped to receive the bottom of the pipe.
 3. Pipe culvert frost treatment shall be according to OPSD 803.030 and 803.031.
 4. Condition of excavation is symmetrical about centreline of pipe.
 5. Granular material placed in the haunch area shall be compacted prior to placing and compacting the remainder of the embedment material.
 6. Soil types as defined in the Occupational Health and Safety Act and Regulations for Construction Projects.

CONCRETE BARRIER CURB

DATE: JANUARY 2001
 SET: MARCH 2010
 DWG No.: SC1.1

NOTES:
 1. THE FULL CURB DEPTH SHALL BE CARRIED THROUGH THE DEPRESSURE CROSSING.
 2. A CONCRETE SURFACE IS REQUIRED WHERE NEARLY ADJACENT TO THE SIDEWALK.
 3. IF AN EXTENDED CURBING MACHINE IS USED, THE #10 CHAINS ARE TO BE PLACED AT THE END OF THE EXTRUSION.
 4. ALL DIMENSIONS ARE IN MILLIMETRES UNLESS SHOWN OTHERWISE.
 5. DOWNY JOINTS SHALL BE 25mm DEEP FRONT, BACK AND TOP OF SECTION AT JOINTS.
 6. FOR DEPRESSURE CURBS AT ENTRANCES USE (20).
 7. DEPRESSURE CURB HEIGHT FOR PEDESTRIAN CURB RAMP IS TO 6mm AND FOR PRIVATE ENTRANCES TO 20mm.

MONOLITHIC CONCRETE CURB AND SIDEWALK

DATE: MAY 2001
 SET: MARCH 2010
 DWG No.: SC2

NOTES:
 1. ALL DIMENSIONS ARE IN MILLIMETRES UNLESS SHOWN OTHERWISE.
 2. THE MAXIMUM SLOPE IS NOT TO EXCEED 2%.
 3. FOR CURB RAMP SLOPE OF 2% TO 3% MAXIMUM IS 3%.
 4. EXPANSION AND DOWNY JOINTS AS PER ICS.
 5. ALL DIMENSIONS ARE IN MILLIMETRES UNLESS SHOWN OTHERWISE.
 6. DEPRESSION TO BE THE INVERT OF THE MAIN WATERMAIN OR SEWER CENTERLINE PLUS 10mm.

WATERMAIN CROSSING OVER SEWER

DATE: MAY 2001
 SET: MARCH 2008
 DWG No.: W25.2

NOTES:
 1. BARREL TO BARREL SEPARATION (D) SHALL BE 200mm MINIMUM.
 2. TRENCH DEPTH FOR MAIN UNDER TRENCH SHALL BE 150mm FOR SPECIAL DESIGN.
 3. FOR 300mm INTERNAL AND 400mm EXTERNAL BARRELS BENCH SHALL BE MAX 20° 30'.
 4. CONCRETE FOR TRENCH BLOCKS SHALL BE 20MPa.
 5. REFER TO ICS FOR TRENCH BLOCK REQUIREMENTS.
 6. REFER TO ICS FOR TRENCH BLOCK REQUIREMENTS.
 7. ALL DIMENSIONS ARE IN MILLIMETRES UNLESS SHOWN OTHERWISE.
 8. DEPRESSION TO BE THE INVERT OF THE MAIN WATERMAIN OR SEWER CENTERLINE PLUS 10mm.

VALVE BOX ASSEMBLY

DATE: MAY 2001
 SET: MARCH 2008
 DWG No.: W24

NOTES:
 1. ALL DIMENSIONS ARE IN MILLIMETRES UNLESS SHOWN OTHERWISE.
 2. FOR 200 AND 300mm VALVES AND BENCHING FROM THE CONCRETE BLOCKS AS REQUIRED TO RAISE BELL HIGH ENOUGH TO PREVENT CONTACT WITH THE VALVE BONNET.

GENERAL CONDITIONS OF THE CONTRACT FOR CONSTRUCTION ARE PART OF THE CONTRACT DOCUMENTS AND DESCRIBE THE SCOPE AND INTENT OF THE DRAWING. THE CONTRACT DOCUMENTS INCLUDE NOT ONLY THE DRAWING, BUT ALSO THE OWNER-CONTRACTOR AGREEMENTS, CONDITIONS OF THE CONTRACT, THE SPECIFICATIONS, ADDENDA, AND MODIFICATIONS ISSUED AFTER EXECUTION OF THE CONTRACT. THESE CONTRACT DOCUMENTS ARE COMPLEMENTARY, AND WHAT IS REQUIRED BY ANY ONE SHALL BE BINDING AS IF REQUIRED BY ALL. WORK NOT COMPLETED HEREON SHALL BE CONSIDERED TO BE OF THE SAME MATERIALS AND DETAILED SIMILARLY AS WORK SHOWN MORE COMPLETELY ELSEWHERE IN THE CONTRACT DOCUMENTS.

BY USE OF THE DRAWINGS FOR CONSTRUCTION OF THE PROJECT, THE OWNER CONFIRMS THAT HE HAS REVIEWED AND APPROVED THE DRAWINGS. THE CONTRACTOR CONFIRMS THAT HE HAS VISITED THE SITE, FAMILIARIZED HIMSELF WITH THE LOCAL CONDITIONS, VERIFIED FIELD DIMENSIONS AND CORRELATED HIS OBSERVATIONS WITH THE REQUIREMENTS OF THE CONTRACT DOCUMENTS.

AS INSTRUMENTS OF SERVICE, ALL DRAWINGS, SPECIFICATIONS, CAD FILES OR OTHER ELECTRONIC MEDIA AND COPIES THEREOF OR FURNISHED BY THE ENGINEER ARE HIS PROPERTY. THEY ARE TO BE USED ONLY FOR THIS PROJECT AND ARE NOT TO BE USED ON ANY OTHER PROJECT, INCLUDING REPEATS OF THE PROJECT. CHANGES TO THE DRAWINGS MAY ONLY BE MADE BY THE ENGINEER.

UNLESS THE REVISION TITLE IS ISSUED FOR CONSTRUCTION, THESE DRAWINGS SHALL BE CONSIDERED PRELIMINARY AND SHALL NOT BE USED AS A CONSTRUCTION DOCUMENT.

THESE DRAWINGS ILLUSTRATE THE WORK TO BE DONE. THE ENGINEER IS NOT RESPONSIBLE FOR THE MEANS, METHODS, TECHNIQUES, SEQUENCES, AND PROCEDURES USED TO DO THE WORK, OR THE SAFETY ASPECTS OF CONSTRUCTION, AND NOTHING ON THESE DRAWINGS EXPRESSED OR IMPLIED CHANGES THIS CONDITION. CONTRACTOR SHALL DETERMINE ALL CONDITIONS AT THE SITE AND SHALL BE RESPONSIBLE FOR KNOWING HOW THEY AFFECT THE WORK. SUBMITTAL OF A BID TO PERFORM THIS WORK IS ACKNOWLEDGEMENT OF THE RESPONSIBILITIES, AND THAT THEY HAVE BEEN FULLY CONSIDERED IN PLANNING OF THE WORK, AND THE BID PRICE. NO CLAIMS FOR EXTRA CHARGES DUE TO THESE CONDITIONS WILL BE FORTHCOMING.

UNAUTHORIZED CHANGES:
 IN THE EVENT OF THE CLIENT, THE CLIENT'S CONTRACTORS OR SUBCONTRACTORS, OR ANYONE FOR WHOM THE CLIENT IS LEGALLY LIABLE MAKES OR PERMITS TO BE MADE ANY CHANGES TO ANY REPORTS, PLANS, SPECIFICATIONS OR OTHER CONSTRUCTION DOCUMENTS PREPARED BY LRL ASSOCIATES LTD. (LRL) WITHOUT OBTAINING LRL'S PRIOR WRITTEN CONSENT, THE CLIENT SHALL ASSUME FULL RESPONSIBILITY FOR THE RESULTS OF SUCH CHANGES. THEREFORE THE CLIENT AGREES TO WAIVE ANY CLAIM AGAINST LRL AND TO RELEASE LRL FROM ANY LIABILITY ARISING DIRECTLY OR INDIRECTLY FROM SUCH UNAUTHORIZED CHANGES.

IN ADDITION, THE CLIENT AGREES TO INCLUDE IN ANY CONTRACT FOR CONSTRUCTION APPROPRIATE LANGUAGE THAT PROHIBITS THE CONTRACTOR OR ANY SUBCONTRACTORS OF ANY TIER FROM MAKING ANY CHANGES OR MODIFICATIONS TO LRL'S CONSTRUCTION DOCUMENTS WITHOUT THE PRIOR WRITTEN APPROVAL OF LRL AND THAT FURTHER INQUIRES THE CONTRACTOR TO INQUIRE BOTH LRL AND THE CLIENT FROM ANY LIABILITY OR COST ARISING FROM SUCH CHANGES MADE WITHOUT SUCH PROPER AUTHORIZATION.

GENERAL NOTES:
 EXISTING SERVICES AND UTILITIES SHOWN ON THESE DRAWINGS ARE TAKEN FROM THE BEST AVAILABLE RECORDS, BUT MAY NOT BE COMPLETE OR TO DATE. CONTRACTOR SHALL VERIFY IN FIELD FOR LOCATION AND ELEVATION OF PIPES AND CHECK WITH THE UTILITY COMPANIES BEFORE DIGGING OR PERFORMING WORK.

CONTRACTOR IS ADVISED TO COLLECT INFORMATION ON SOIL CONDITIONS BEFORE START OF CONSTRUCTION.

THE ENGINEER WAIVES ANY AND ALL RESPONSIBILITY AND LIABILITY FOR PROBLEMS WHICH ARISE FROM FAILURE TO FOLLOW THESE PLANS, SPECIFICATIONS AND THE DESIGN INTENT THEY COVER, OR FOR PROBLEMS WHICH ARISE FROM OTHERS' FAILURE TO OBTAIN AND/OR FOLLOW THE ENGINEER'S GUIDANCE WITH RESPECT TO ANY ERRORS, OMISSIONS, INCONSISTENCIES AMBIGUITIES OR CONFLICTS WHICH ARE ALLEGED.

CONTRACTOR TO VERIFY ALL DIMENSIONS AND NOTIFY THE ENGINEER OF ANY DISCREPANCIES BEFORE WORK COMMENCES. DO NOT SCALE DRAWINGS.

01 ISSUED FOR SPA G.M.C. 13 DEC 2017

No. REVISIONS BY DATE

LICENCED PROFESSIONAL ENGINEER
 J. C. R. LALONDE
 DEC 13/2017
 PROVINCE OF ONTARIO

NOT AUTHENTIC UNLESS SIGNED AND DATED

ENGINEERING | INGENIERIE
 5430 Canotek Road | Ottawa, ON, K1J 9G2
 www.lrl.ca | (613) 842-3434

CLIENT
 GRAEBECK CONSTRUCTION LTD.

DESIGNED BY: G.M.C. DRAWN BY: G.M.C. APPROVED BY: J.C.L.

PROJECT
 2465070 ONTARIO LTD.
 2375 ST-LAURENT BLVD., OTTAWA, ON

DRAWING TITLE
 CONSTRUCTION DETAIL PLAN

PROJECT NO.
 170721

DATE
 13 DEC 2017

C901



2465070 ONTARIO LTD
2375 ST-LAURENT BLVD., OTTAWA, ON

STORMTECH CHAMBER SPECIFICATIONS

- CHAMBERS SHALL BE STORMTECH MC-3000 OR APPROVED EQUIV.
- CHAMBERS SHALL BE MADE FROM VIRGIN, IMPACT MODIFIED POLYPROPYLENE COPOLYMERS.
- CHAMBER JOINTS SHALL PROVIDE CONTINUOUS, UNINTERRUPTED INTERNAL SPACE WITH NO INTERNAL SUPPORT PANELS THAT WOULD IMPIDE FLOW OR LIMIT ACCESS FOR INSPECTION.
- THE STRUCTURAL DESIGN OF THE CHAMBERS, THE STRUCTURAL BACKFILL, AND THE INSTALLATION REQUIREMENTS SHALL ENSURE THAT THE LOAD FACTORS SPECIFIED IN THE AASHTO LRFD BRIDGE DESIGN SPECIFICATIONS, SECTION 12.12, ARE MET FOR 1) LONG-DURATION DEAD LOADS AND 2) SHORT-DURATION LIVE LOADS, BASED ON THE AASHTO DESIGN TRUCK WITH CONSIDERATION FOR IMPACT AND MULTIPLE VEHICLE PRESENCE.
- CHAMBERS SHALL MEET THE REQUIREMENTS OF ASTM F2419, "STANDARD SPECIFICATION FOR POLYPROPYLENE (PP) CORRUGATED WALL STORMWATER COLLECTION CHAMBERS".
- CHAMBERS SHALL BE DESIGNED AND ALLOWABLE LOADS DETERMINED IN ACCORDANCE WITH ASTM F1977, "STANDARD PRACTICE FOR STRUCTURAL DESIGN OF THERMOPLASTIC CORRUGATED WALL STORMWATER COLLECTION CHAMBERS".
- ONLY CHAMBERS THAT ARE APPROVED BY THE SITE DESIGN ENGINEER WILL BE ALLOWED. THE CHAMBER MANUFACTURER SHALL SUBMIT THE FOLLOWING UPON REQUEST TO THE SITE DESIGN ENGINEER FOR APPROVAL BEFORE ERECTING CHAMBERS TO THE PROJECT SITE:
 - A STRUCTURAL EVALUATION PERFORMED BY A REGISTERED PROFESSIONAL ENGINEER THAT DEMONSTRATES THAT THE SAFETY FACTORS ARE GREATER THAN OR EQUAL TO 1.5 FOR DEAD LOAD AND 1.75 FOR LIVE LOAD, THE MINIMUM REQUIRED BY ASTM F1977 AND BY AASHTO FOR THERMOPLASTIC.
 - A STRUCTURAL EVALUATION PERFORMED BY A REGISTERED PROFESSIONAL ENGINEER THAT DEMONSTRATES THAT THE LOAD FACTORS SPECIFIED IN THE AASHTO LRFD BRIDGE DESIGN SPECIFICATIONS, SECTION 12.12, ARE MET, THE 10-YEAR CREEP MODULUS DATA SPECIFIED IN ASTM F2419 MUST BE USED AS PART OF THE AASHTO STRUCTURAL EVALUATION TO VERIFY LONG-TERM PERFORMANCE.
 - STRUCTURAL CROSS SECTION DETAILS, ON WHICH THE STRUCTURAL EVALUATION IS BASED.
- CHAMBERS AND END CAPS SHALL BE PROCESSED AT AN ISO 9001 CERTIFIED MANUFACTURING FACILITY.

IMPORTANT - NOTES FOR THE BIDDING AND INSTALLATION OF MC-3500 CHAMBER SYSTEM

- STORMTECH MC-3000 CHAMBERS SHALL NOT BE INSTALLED UNTIL THE MANUFACTURER'S REPRESENTATIVE HAS COMPLETED A PRE-CONSTRUCTION MEETING WITH THE INSTALLERS.
- STORMTECH MC-3000 CHAMBERS SHALL BE INSTALLED IN ACCORDANCE WITH THE "STORMTECH MC-3000/MC-4000 CONSTRUCTION GUIDE".
- CHAMBERS ARE NOT TO BE BACKFILLED WITH A DOZER OR AN EXCAVATOR SITUATED OVER THE CHAMBERS.
 - STORMTECH RECOMMENDS 3 BACKFILL METHODS:
 - STONE BACKFILL LOCATED OUTSIDE THE CHAMBER BED.
 - BACKFILL AS SHOWN ARE BEHIND AN EXCAVATOR ON THE EXCAVATION SIDE OR SUBGRADE.
 - BACKFILL FROM OUTSIDE THE EXCAVATION USING A LONG BOOM HOE EXCAVATOR.
 - THE FOUNDATION STONE SHALL BE LEVELLED AND COMPACTED PRIOR TO PLACING CHAMBERS.
- JOINTS BETWEEN CHAMBERS SHALL BE PROPERLY BEATED PRIOR TO PLACING STONE.
- MAINTAIN WORKING 2" (50 mm) SPACING BETWEEN THE CHAMBER ROWS.
- INLET AND OUTLET MANHOLES MUST BE NESTED A MINIMUM OF 12" (305 mm) INTO CHAMBER END CAPS.
- EMBEDMENT STONE SURROUNDING CHAMBERS MUST BE A CLEAN, CRUSHED, ANGULAR STONE 3/4" (20.0 mm) MEETING THE AASHTO M3 DESIGNATION OF #3 OR #4 1/2.
- STONE MUST BE PLACED ON THE TOP CENTER OF THE CHAMBER TO ANCHOR THE CHAMBERS IN PLACE AND PRESERVE ROW SPACING. 1) USE OF A DOZER TO PUSH EMBEDMENT STONE BETWEEN THE ROWS OF CHAMBERS MAY CAUSE DAMAGE TO CHAMBERS AND IS NOT AN ACCEPTABLE BACKFILL METHOD. ANY CHAMBERS DAMAGED BY USING THE "DOZER AND PUSH" METHOD ARE NOT COVERED UNDER THE STORMTECH STANDARD WARRANTY.

NOTES FOR CONSTRUCTION EQUIPMENT

- STORMTECH MC-3000 CHAMBERS SHALL BE INSTALLED IN ACCORDANCE WITH THE "STORMTECH MC-3000/MC-4000 CONSTRUCTION GUIDE". 1) THE USE OF EQUIPMENT OVER MC-3000 CHAMBERS IS LIMITED TO:
 - NO EQUIPMENT IS ALLOWED ON CHAMBER CHAMBERS.
 - NO TRUCKS, TRACTORS, OR EXCAVATORS ARE ALLOWED UNTIL PROPER FILL DEPTH IS REACHED IN ACCORDANCE WITH THE "STORMTECH MC-3000/MC-4000 CONSTRUCTION GUIDE".
 - WEIGHT LIMITS FOR CONSTRUCTION EQUIPMENT CAN BE FOUND IN THE "STORMTECH MC-3000/MC-4000 CONSTRUCTION GUIDE".
- FULL 30" (762 mm) OF STABILIZED COVER MATERIAL OVER THE CHAMBERS IS REQUIRED FOR DUMP TRUCK TRAVEL OR DRIVING. 1) USE OF A DOZER TO PUSH EMBEDMENT STONE BETWEEN THE ROWS OF CHAMBERS MAY CAUSE DAMAGE TO CHAMBERS AND IS NOT AN ACCEPTABLE BACKFILL METHOD. ANY CHAMBERS DAMAGED BY USING THE "DOZER AND PUSH" METHOD ARE NOT COVERED UNDER THE STORMTECH STANDARD WARRANTY.

CONTACT STORMTECH AT 1-888-886-2884 WITH ANY QUESTIONS ON INSTALLATION REQUIREMENTS OR WEIGHT LIMITS FOR CONSTRUCTION EQUIPMENT.

CONCEPTUAL LAYOUT

(SEE STORMTECH MC-3000 CHAMBERS) (SEE STORMTECH MC-3500 END CAPS) INSTALLED WITH 200 mm COVER STONE, 229 mm BASE STONE, 40% STONE VOID INSTALLED WITH VOLUME: 133 m³ AREA OF SYSTEM: 133 m² PERIMETER OF SYSTEM: 66 m

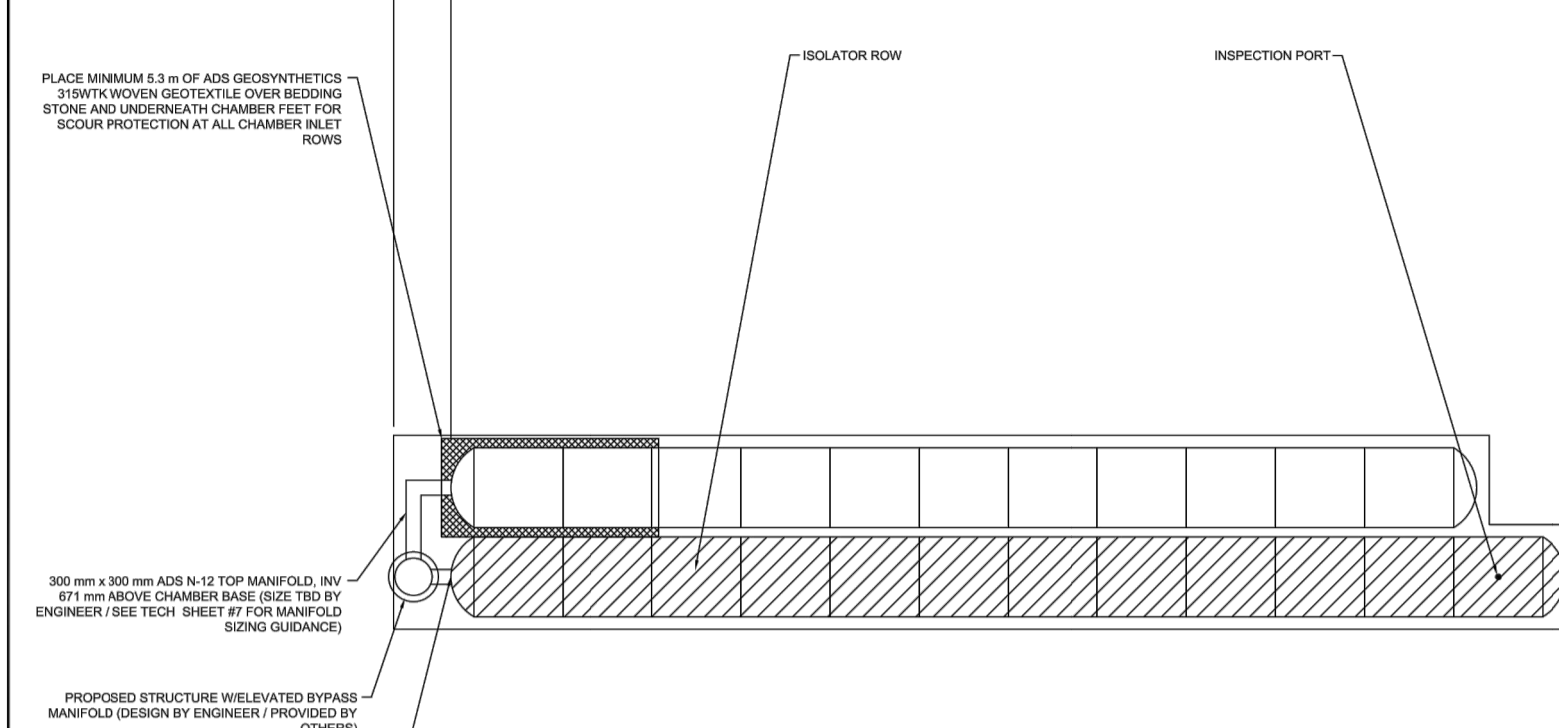

PLACE MINIMUM 1.5 m OF ADE GEOTEXTILES 319WTV WOVEN GEOTEXTILE OVER BEDDING STONE AND UNDER CHAMBER SET FOR SCOUR PROTECTION AT ALL CHAMBER INLET ROWS.

300 mm x 300 mm AAS N-12 TOP MANHOLE, HW 871 mm ABOVE CHAMBER BASE (822 T80 BY ENGINEER (SEE TECH. SHEET #7) FOR MANHOLE (SEE GUIDANCE))

PROPOSED STRUCTURE WELVEATED BY BAYAS MANHOLE DESIGN (IF ENGINEER PROVIDED OTHERS)

600 mm COVERED END CAP PART# MC3000EPPBC TYP FOR ALL MC-3000 600 mm CONNECTIONS AND ISOLATOR ROWS

ACCEPTABLE FILL MATERIALS: STORMTECH MC-3000 CHAMBER SYSTEMS

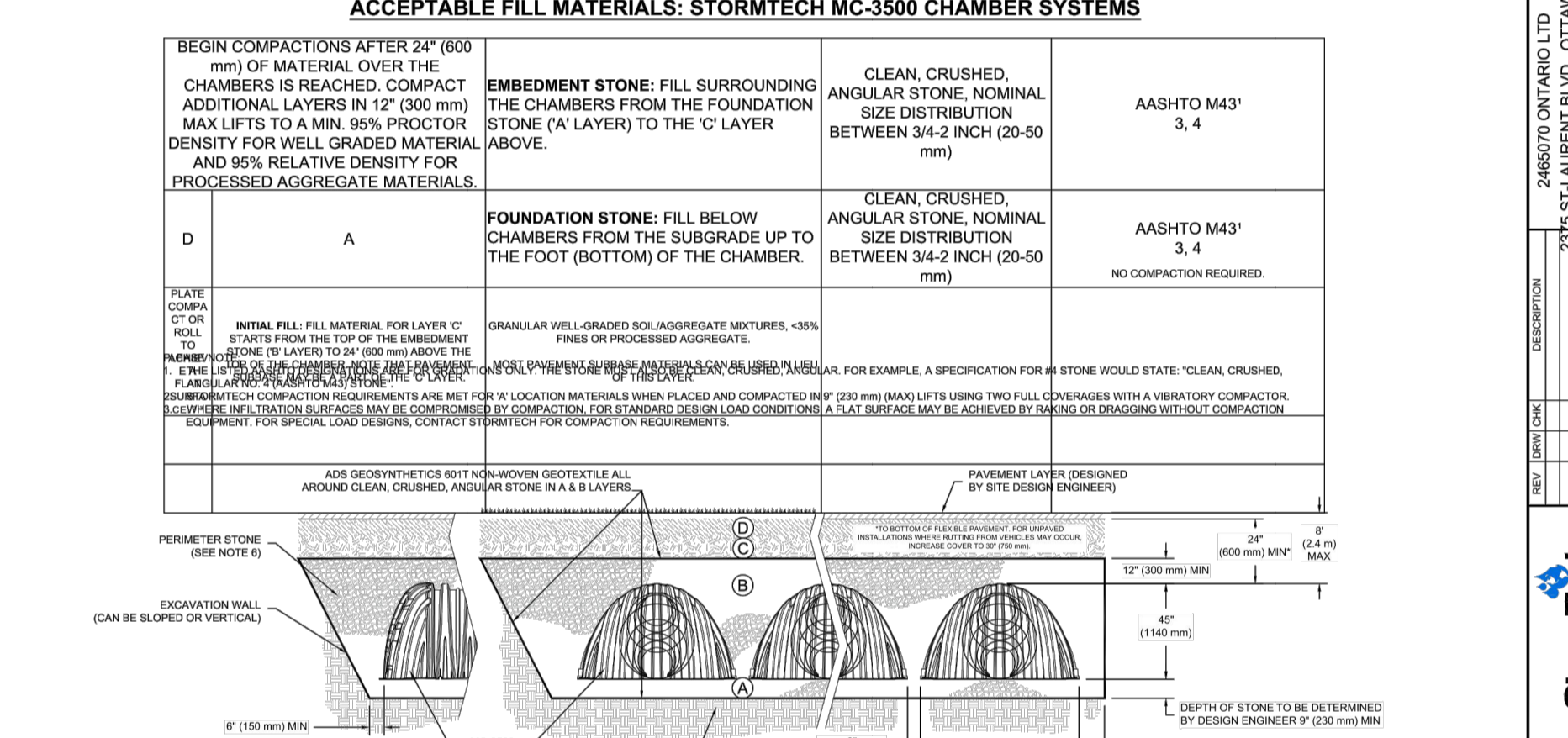

- NOTES:**
- MC-3000 CHAMBERS SHALL CONFORM TO THE REQUIREMENTS OF ASTM F2419, "STANDARD SPECIFICATION FOR POLYPROPYLENE (PP) CORRUGATED WALL STORMWATER COLLECTION CHAMBERS".
 - MC-3000 CHAMBERS SHALL BE DESIGNED IN ACCORDANCE WITH ASTM F1977, "STANDARD PRACTICE FOR STRUCTURAL DESIGN OF THERMOPLASTIC CORRUGATED WALL STORMWATER COLLECTION CHAMBERS".
 - "ACCEPTABLE FILL MATERIALS" TABLE ABOVE PROVIDES MATERIAL, LOCATION, DESCRIPTION, GRADATIONS, AND COMPACTION REQUIREMENTS FOR FOUNDATION, EMBEDMENT, AND FILL MATERIALS. 1) THE SITE DESIGN ENGINEER'S RESPONSIBILITY FOR THE DESIGN AND LAYOUT OF THE STORMTECH CHAMBERS FOR THIS PROJECT.
 - THE SITE DESIGN ENGINEER IS RESPONSIBLE FOR ASSESSING THE BEARING RESISTANCE (ALLOWABLE BEARING CAPACITY) OF THE SUBGRADE SOILS AND THE DEPTH OF FOUNDATION STONE WITH CONSIDERATION FOR THE RANGE OF EXPECTED SOIL MOISTURE CONDITIONS. 1)
 - FOUNDATION STONE MUST BE EXTENDED HORIZONTALLY TO THE EXCAVATION WALL FOR BOTH VERTICAL AND SLOPED EXCAVATION WALLS.
 - ONCE LAYER 'C' IS PLACED, ANY SOIL MATERIAL CAN BE PLACED IN LAYER 'D' UP TO THE FINISHED GRADE. MOST PAVEMENT SUBBASE SOILS CAN BE USED TO REPLACE THE MATERIAL REQUIREMENTS OF LAYER 'C' OR 'D' AT THE SITE DESIGN ENGINEER'S DISCRETION.

MC-3500 ISOLATOR ROW DETAIL

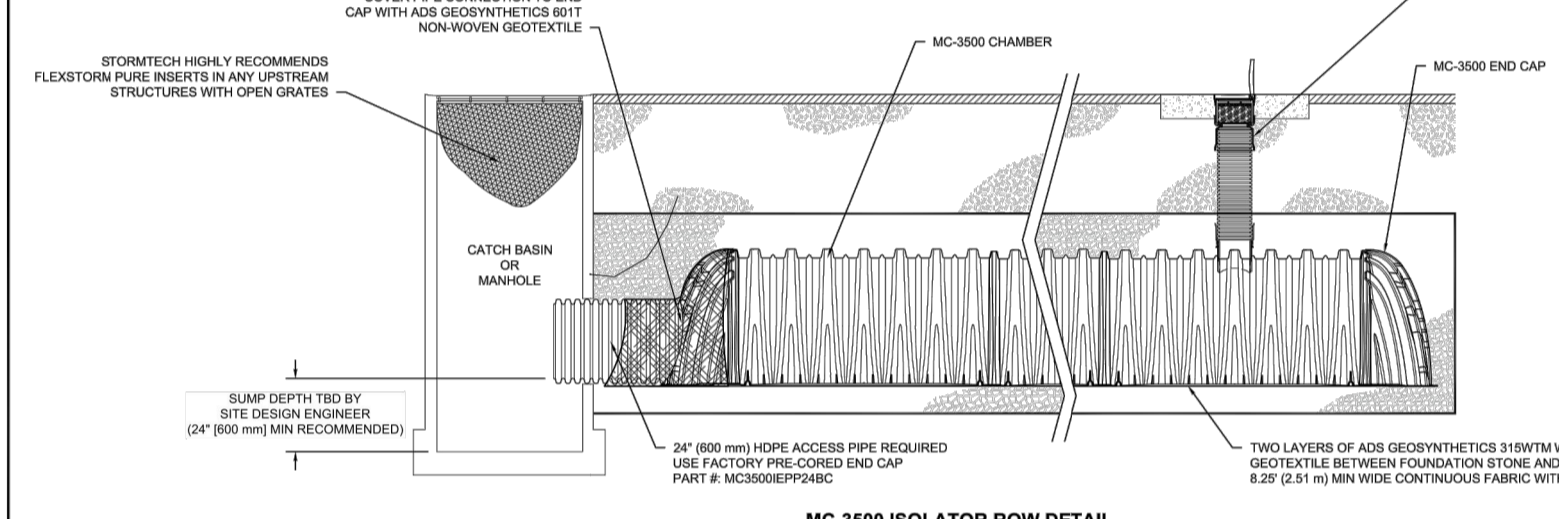

INSPECTION & MAINTENANCE

- STEP 1) INSPECT ISOLATOR ROW FOR SEDIMENT
- REMOVE SEDIMENT FROM ISOLATOR ROW.
 - REMOVE AND CLEAN EXISTING FILTER IF INSTALLED.
 - USING A FLASHLIGHT AND STADIUM ROD, MEASURE DEPTH OF SEDIMENT AND RECORD ON MAINTENANCE LOG.
 - COVER CAMERA INTO ISOLATOR ROW FOR VISUAL INSPECTION OF SEDIMENT LEVELS (OPTIONAL).
 - IF SEDIMENT IS AT OR ABOVE 75 mm (3") PROCEED TO STEP 2. IF NOT, PROCEED TO STEP 3.
- STEP 2) CLEAN OUT ISOLATOR ROW USING THE AT-VAC PROCESS
- A FLEXIBLE CLEANING NOZZLE WITH REAR FACING BRUSH OF 40" (1.1 m) OR MORE IS PREFERRED.
 - APPLY MULTIPLE PASSES OF AT-VAC BACKLASH WATER IS CLEAN.
 - VACUUM STRUCTURE SLUMP AS REQUIRED.
- STEP 3) REPLACE ALL COVER GRATES, FILTERS, AND LIDS. RECORD OBSERVATIONS AND ACTION.
- STEP 4) INSPECT AND CLEAN BASINS AND MANHOLES UPSTREAM OF THE STORMTECH SYSTEM.

NOTES

- INSPECT EVERY 6 MONTHS DURING THE FIRST YEAR OF OPERATION. ADJUST THE INSPECTION INTERVAL BASED ON PREVIOUS OBSERVATIONS OF SEDIMENT ACCUMULATION AND WATER ELEVATIONS. 1)
- CONDUCT SETTING AND VACUUMING ANNUALLY OR WHEN INSPECTION SHOWS THAT MAINTENANCE IS NECESSARY.

INSERT TEE DETAIL

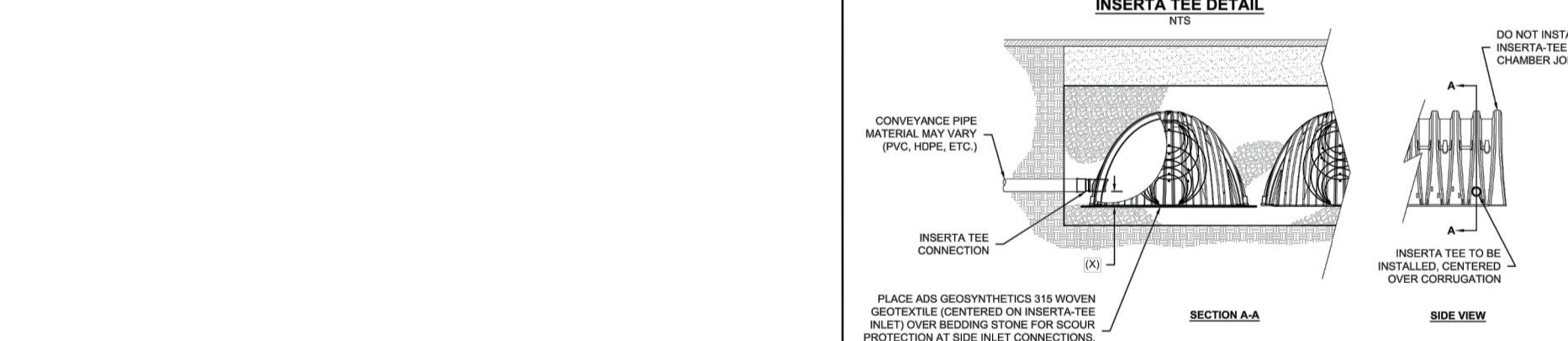

DO NOT INSTALL INSERT TEE AT CHAMBER JOINTS

PLACE ADE GEOTEXTILES 319 WOVEN GEOTEXTILES CENTERED ON INSERT TEE (SEE NOTE 3)

NOTE: INSERT TEE FITTINGS AVAILABLE FOR SCH 40, SCH 80, SCH 40S, GASKETED & SOLVENT WELD, N-12, HP STORM, C-300 OR OUTLET IRON

MC-SERIES END CAP INSERTION DETAIL

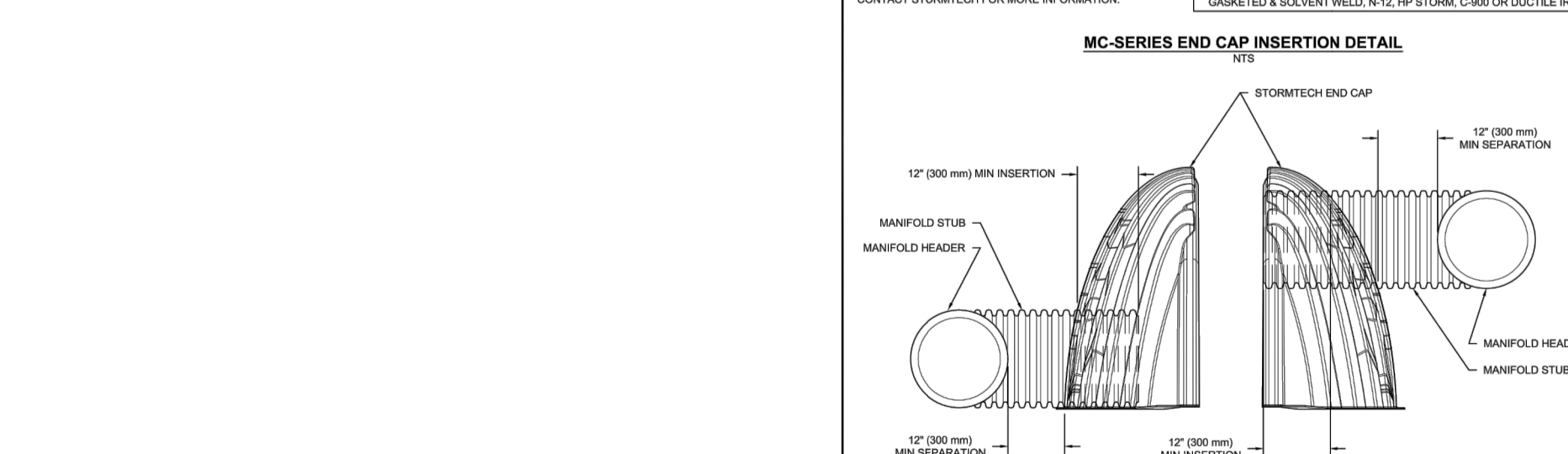

NOTE: MANHOLE STUB MUST BE LINED HORIZONTAL FOR A PROPER FIT IN END CAP OPENING

MC-3500 TECHNICAL SPECIFICATION

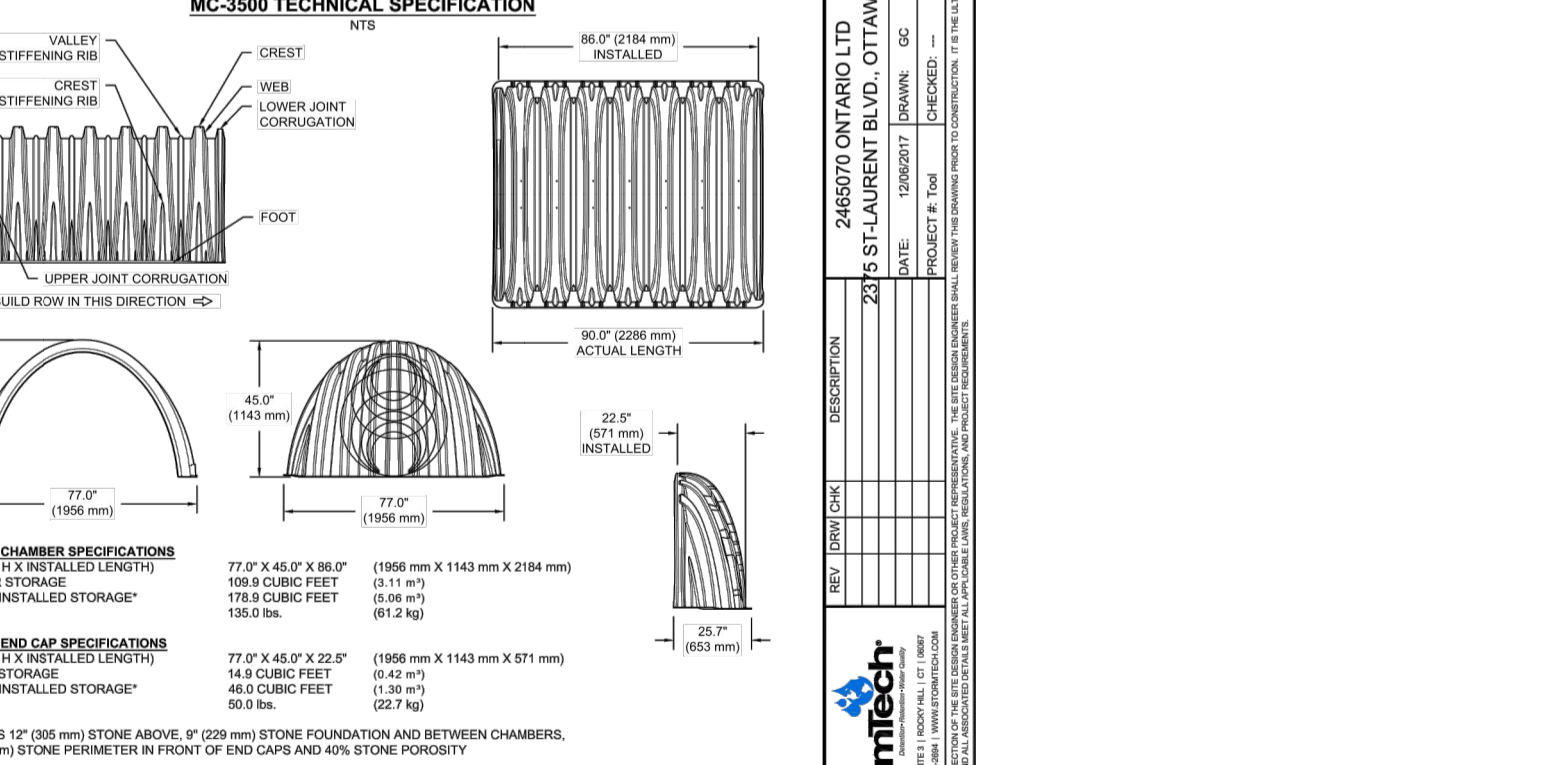

*ASSEMBLE 12" (305 mm) STONE ABOVE, 8" (203 mm) STONE FOUNDATION AND BETWEEN CHAMBERS. 12" (305 mm) STONE PERIMETER IN FRONT OF END CAPS AND 40% STONE POROSITY

STUBS AT BOTTOM OF END CAP FOR PART NUMBERS ENDING WITH "B"

PART #	STUB	B	C
MC3500EPP0BT	6" (150 mm)	33 21" (844 mm)	—
MC3500EPP0BT	8" (200 mm)	31 18" (791 mm)	0.68" (17 mm)
MC3500EPP1BT	10" (250 mm)	29 04" (738 mm)	0.87" (22 mm)
MC3500EPP1BT	12" (300 mm)	26 50" (678 mm)	0.87" (22 mm)
MC3500EPP1BT	14" (350 mm)	24 36" (619 mm)	1.30" (34 mm)
MC3500EPP1BT	16" (400 mm)	22 22" (562 mm)	1.87" (48 mm)
MC3500EPP1BT	18" (450 mm)	20 08" (505 mm)	1.77" (45 mm)
MC3500EPP1BT	20" (500 mm)	17 54" (450 mm)	2.56" (65 mm)

NOTE: ALL DIMENSIONS ARE NOMINAL

CUSTOM PRECISED INVERTS ARE AVAILABLE UPON REQUEST. INVENTORIED MANHOLES INCLUDE 12" (305 mm) MIN. SIZE ON SIDE AND 14" (355 mm) MIN. SIZE ON END. END CAP OUT IN THE FIELD ARE NOT RECOMMENDED FOR PIPE SIZES GREATER THAN 12" (305 mm).

THE INVERT LOCATION IN COLUMN B ARE THE HIGHEST POSSIBLE FOR THE PIPE SIZE.

2465070 ONTARIO LTD
2375 ST-LAURENT BLVD., OTTAWA, ON
PROJECT # 2465070
SHEET 2 OF 5

2465070 ONTARIO LTD
2375 ST-LAURENT BLVD., OTTAWA, ON
PROJECT # 2465070
SHEET 4 OF 5

2465070 ONTARIO LTD
2375 ST-LAURENT BLVD., OTTAWA, ON
PROJECT # 2465070
SHEET 5 OF 5

GENERAL CONDITIONS OF CONTRACT FOR CONSTRUCTION

GENERAL CONDITIONS OF THE CONTRACT FOR CONSTRUCTION ARE PART OF THE CONTRACT DOCUMENTS AND DESCRIBE THE USE AND INTENT OF THE DRAWING. THE CONTRACT DOCUMENTS INCLUDE NOT ONLY THE DRAWING, BUT ALSO THE OWNER-CONTRACTOR AGREEMENTS, CONDITIONS OF THE CONTRACT, THE SPECIFICATIONS, ADDENDA, AND MODIFICATIONS ISSUED AFTER EXECUTION OF THE CONTRACT. THESE CONTRACT DOCUMENTS ARE COMPLEMENTARY, AND WHAT IS REQUIRED BY ANY ONE SHALL BE BINDING AS IF REQUIRED BY ALL. WORK NOT COMPLETELY DELINEATED HEREON SHALL BE CONSTRUCTED OF THE SAME MATERIALS AND DETAIL AS SHOWN MORE COMPLETELY ELSEWHERE IN THE CONTRACT DOCUMENTS.

BY USE OF THE DRAWINGS FOR CONSTRUCTION OF THE PROJECT, THE OWNER CONFIRMS THAT HE HAS REVIEWED AND APPROVED THE DRAWINGS. THE CONTRACTOR CONFIRMS THAT HE HAS VISITED THE SITE, FAMILIARIZED HIMSELF WITH THE LOCAL CONDITIONS, VERIFIED FIELD DIMENSIONS AND CORRELATED HIS OBSERVATIONS WITH THE REQUIREMENTS OF THE CONTRACT DOCUMENTS.

AS INSTRUMENTS OF SERVICE, ALL DRAWINGS, SPECIFICATIONS, CADD FILES OR OTHER ELECTRONIC MEDIA AND COPIES THEREOF FURNISHED BY THE ENGINEER ARE HIS PROPERTY. THEY ARE TO BE USED ONLY FOR THIS PROJECT AND ARE NOT TO BE USED ON ANY OTHER PROJECT, INCLUDING REPEATS OF THE PROJECT. CHANGES TO THE DRAWINGS MAY ONLY BE MADE BY THE ENGINEER.

UNLESS THE REVISION TITLE IS ISSUED FOR CONSTRUCTION, THESE DRAWINGS SHALL BE CONSIDERED PRELIMINARY AND SHALL NOT BE USED AS A CONSTRUCTION DOCUMENT.

THESE DRAWINGS ILLUSTRATE THE WORK TO BE DONE. THE ENGINEER IS NOT RESPONSIBLE FOR THE MEANS, METHODS, TECHNIQUES, SEQUENCES, AND PROCEDURES USED TO DO THE WORK, OR THE SAFETY ASPECTS OF CONSTRUCTION, AND NOTHING ON THESE DRAWINGS EXPRESSED OR IMPLIED CHANGES THIS CONDITION. CONTRACTOR SHALL DETERMINE ALL CONDITIONS AT THE SITE AND SHALL BE RESPONSIBLE FOR KNOWING HOW THEY AFFECT THE WORK. SUBMITTAL OF A BID TO PERFORM THIS WORK IS ACKNOWLEDGEMENT OF THE RESPONSIBILITIES, AND THAT THEY HAVE BEEN FULLY CONSIDERED IN PLANNING OF THE WORK, AND THE BID PRICE. NO CLAIMS FOR EXTRA CHARGES DUE TO THESE CONDITIONS WILL BE FORTHCOMING.

UNAUTHORIZED CHANGES

IN THE EVENT THE CLIENT, THE CLIENT'S CONTRACTORS OR SUBCONTRACTORS, OR ANYONE FOR WHOM THE CLIENT IS LEGALLY LIABLE MAKES OR PERMITS TO BE MADE ANY CHANGES TO ANY REPORTS, PLANS, SPECIFICATIONS OR OTHER CONSTRUCTION DOCUMENTS PREPARED BY LRL ASSOCIATES LTD. (LRL) WITHOUT OBTAINING LRL'S PRIOR WRITTEN CONSENT, THE CLIENT SHALL ASSUME FULL RESPONSIBILITY FOR THE RESULTS OF SUCH CHANGES. THEREFORE THE CLIENT AGREES TO WAIVE ANY CLAIM AGAINST LRL AND TO RELEASE LRL FROM ANY LIABILITY ARISING DIRECTLY OR INDIRECTLY FROM SUCH UNAUTHORIZED CHANGES.

IN ADDITION, THE CLIENT AGREES TO THE FULLEST EXTENT PERMITTED BY LAW, TO INDEMNIFY AND HOLD HARMLESS LRL FROM ANY DAMAGES, LIABILITIES OR COSTS, INCLUDING REASONABLE ATTORNEY'S FEES AND COST OF DEFENSE, ARISING FROM SUCH CHANGES.

GENERAL NOTES:
EXISTING SERVICES AND UTILITIES SHOWN ON THESE DRAWINGS ARE TAKEN FROM THE BEST AVAILABLE RECORDS, BUT MAY NOT BE COMPLETE OR TO DATE. CONTRACTOR SHALL VERIFY IN FIELD FOR LOCATION AND ELEVATION OF PIPES AND CHECK WITH THE UTILITY COMPANIES BEFORE DIGGING OR PERFORMING WORK.

CONTRACTOR IS ADVISED TO COLLECT INFORMATION ON SOIL CONDITIONS BEFORE START OF CONSTRUCTION.

THE ENGINEER WAIVES ANY AND ALL RESPONSIBILITY AND LIABILITY FOR PROBLEMS WHICH ARISE FROM FAILURE TO FOLLOW THESE PLANS, SPECIFICATIONS AND THE DESIGN INTENT THEY CONVEY, OR FOR PROBLEMS WHICH ARISE FROM OTHERS' FAILURE TO OBTAIN AND/OR FOLLOW THE ENGINEER'S GUIDANCE WITH RESPECT TO ANY PERMITS, OMISSIONS, INCONSISTENCIES AMBIGUITIES OR CONFLICTS WHICH ARE ALLEGED.

CONTRACTOR TO VERIFY ALL DIMENSIONS AND NOTIFY THE ENGINEER OF ANY DISCREPANCIES BEFORE WORK COMMENCES. DO NOT SCALE DRAWINGS.

No.	ISSUED FOR SPA	G.M.C.	13 DEC 2017
01	ISSUED FOR SPA	G.M.C.	13 DEC 2017



NOT AUTHENTIC UNLESS SIGNED AND DATED

LRJ
ENGINEERING | INGENIERIE
5430 Canotek Road | Ottawa, ON, K1J 9G2
www.lrl.ca | (613) 842-3434

CLIENT: GRAEBECK CONSTRUCTION LTD.

DESIGNED BY: G.M.C. DRAWN BY: G.M.C. APPROVED BY: J.C.L.

PROJECT: 2465070 ONTARIO LTD.
2375 ST-LAURENT BLVD., OTTAWA, ON

DRAWING TITLE: CONSTRUCTION DETAIL PLAN

PROJECT NO. 170721
DATE 13 DEC 2017
C902

APPENDIX H

St-Laurent Blvd. As-Built Drawings



Notes:
Utilities shown are taken from best available records. Contractor is requested to check with all utility companies before digging.
Soil information shown is not guaranteed and contractors are advised to collect additional soil information as deemed necessary.
Reference bench mark:

Notes (Sewer Construction Only)
A minimum of 450 mm vertical clearance to be maintained between sewers and watermains where practical.
Borehole soil descriptions are not based on sieve analysis but on visual inspection only, except where otherwise noted.
Soil information taken from:
Date of television inspection:
This plan supersedes (in whole or in part) plan no:
Actual rock line recorded during construction of existing sewer.
Registered plan no:
See additional notes on sheet # 1.
Proposed storm and sanitary sewers may be constructed in a common trench provided that a minimum horizontal distance of 450mm is maintained between outside barrels of pipe.

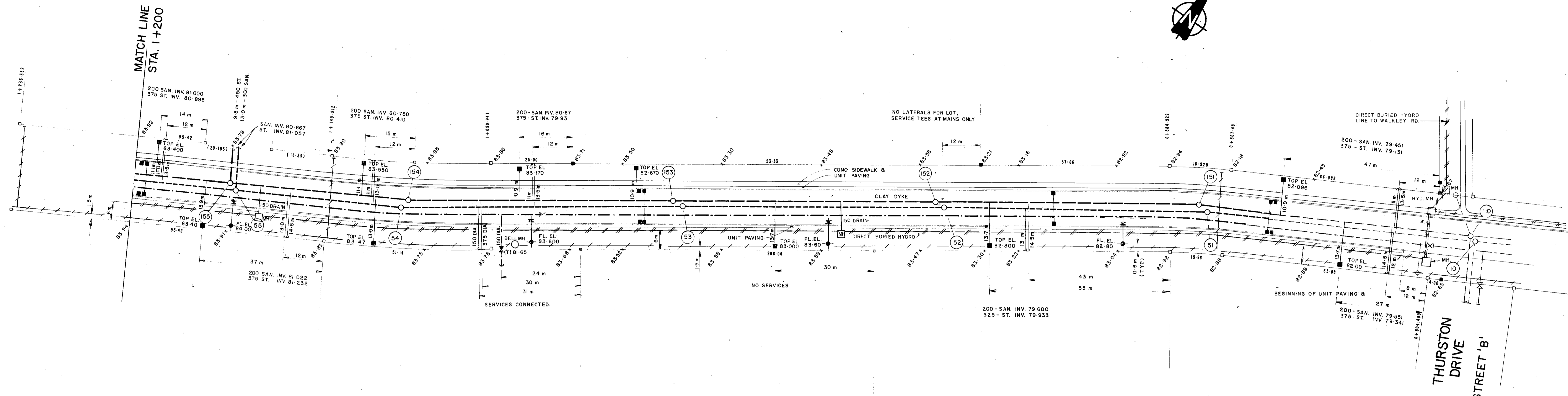

ST. LAURENT BLVD. (EXTENSION)

THURSTON DRIVE
STREET 'B'

DEC. 1985

J.L. Richards & Associates Limited
Consulting Engineers & Planners
J.L.R. JOB NO. 84 - 8460

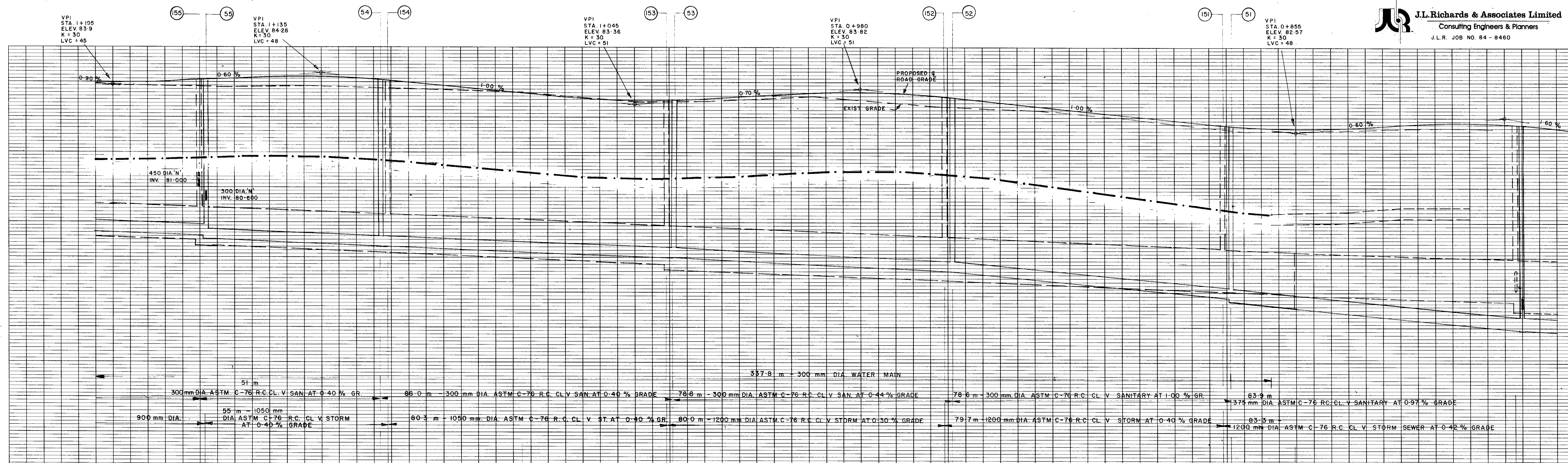

Legend:	EXISTING	PROPOSED
STORM SEWER		
SANITARY SEWER		
STREET LINE		
LOT LINE		
ROADS & DRIVEWAYS		
Curbs		
Asphalt or Concrete		
Surface Treated		
WALKS		
Concrete or Asphalt		
Gravel/Grass or Dirt		
DEPRESSED ACCESS		
On Curb		
On Sidewalk		
WATERMAIN		
GASMAIN & VALVE		
BELL		
HYDRANT		
FIRE ALARM		
CABLEVISION		
STEAM LINE		
HYDRANT		
WATER VALVE		
STAND PIPE		
WATER VALVE CHAMBER		
SEWER TRAFFIC LIGHT & BELL		
MANHOLE		
TRAFFIC HANDHOLE		
GUARD RAIL		
RETAINING WALL		
FENCE		
HYDRO POLE		
HYDRO POLE & LIGHT		
BELL POLE		
TRAFFIC LIGHT		
LIGHT STANDARD		
TRAFFIC SIGN		
STREET SIGN		
CULVERT & DITCH		
STANDARD CATCH-BASIN & LEAD		
HEAVY DUTY CATCH-BASIN & LEAD		
CATCH BASIN TO BE REMOVED & REPLACED WITH STANDARD C.B.		
HEAVY DUTY CATCH-BASIN TO BE REMOVED & REPLACED WITH HEAVY DUTY CATCH-BASIN		
HOUSE OF CATCH-BASIN CONNECTION TAKEN FROM RECORDS		
RELOCATION		
REMOVAL		
SQUARE IRON BAR		
STANDARD IRON BAR		
ROUND IRON BAR		
TREE, SHRUB & HEDGE		
BOREHOLE		
ROCK		

Revisions:				
No	Date	Description	Drawn By	App'd By
1	MARCH 84	SAN SEWER SIZE	J.M.	A.E.F.
2	NOV. 84	RECORD DWS. (SEWER & WM ONLY)	I.T.	R.C.

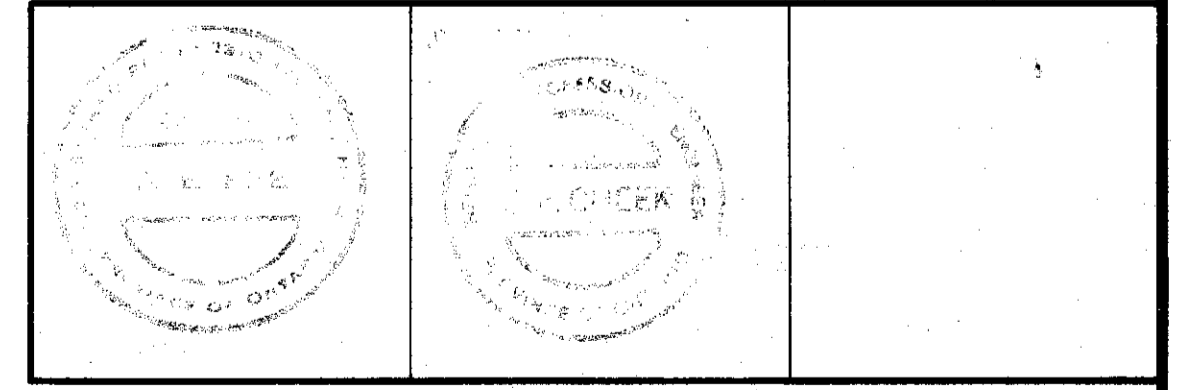

Existing Surface	Proposed Road	Top of Water Main	Type & Diameter (sewer)	Inverts Exist & Prop. (sewer)	Stations
81.7	81.7	81.7	HYDRANT & VALVE 50" DIA.	81.70	1+195
81.7	81.7	81.7	HYDRANT & VALVE 50" DIA.	81.70	1+175
81.7	81.7	81.7	HYDRANT & VALVE 50" DIA.	81.70	1+155
81.7	81.7	81.7	HYDRANT & VALVE 50" DIA.	81.70	1+135
81.7	81.7	81.7	HYDRANT & VALVE 50" DIA.	81.70	1+115
81.7	81.7	81.7	HYDRANT & VALVE 50" DIA.	81.70	1+095
81.7	81.7	81.7	HYDRANT & VALVE 50" DIA.	81.70	1+075
81.7	81.7	81.7	HYDRANT & VALVE 50" DIA.	81.70	1+055
81.7	81.7	81.7	HYDRANT & VALVE 50" DIA.	81.70	1+035
81.7	81.7	81.7	HYDRANT & VALVE 50" DIA.	81.70	1+015
81.7	81.7	81.7	HYDRANT & VALVE 50" DIA.	81.70	1+000
81.7	81.7	81.7	HYDRANT & VALVE 50" DIA.	81.70	0+980
81.7	81.7	81.7	HYDRANT & VALVE 50" DIA.	81.70	0+960
81.7	81.7	81.7	HYDRANT & VALVE 50" DIA.	81.70	0+940
81.7	81.7	81.7	HYDRANT & VALVE 50" DIA.	81.70	0+920
81.7	81.7	81.7	HYDRANT & VALVE 50" DIA.	81.70	0+900
81.7	81.7	81.7	HYDRANT & VALVE 50" DIA.	81.70	0+880
81.7	81.7	81.7	HYDRANT & VALVE 50" DIA.	81.70	0+860
81.7	81.7	81.7	HYDRANT & VALVE 50" DIA.	81.70	0+840
81.7	81.7	81.7	HYDRANT & VALVE 50" DIA.	81.70	0+820
81.7	81.7	81.7	HYDRANT & VALVE 50" DIA.	81.70	0+800
81.7	81.7	81.7	HYDRANT & VALVE 50" DIA.	81.70	0+780
81.7	81.7	81.7	HYDRANT & VALVE 50" DIA.	81.70	0+760
81.7	81.7	81.7	HYDRANT & VALVE 50" DIA.	81.70	0+740
81.7	81.7	81.7	HYDRANT & VALVE 50" DIA.	81.70	0+720
81.7	81.7	81.7	HYDRANT & VALVE 50" DIA.	81.70	0+700
81.7	81.7	81.7	HYDRANT & VALVE 50" DIA.	81.70	0+680
81.7	81.7	81.7	HYDRANT & VALVE 50" DIA.	81.70	0+660
81.7	81.7	81.7	HYDRANT & VALVE 50" DIA.	81.70	0+640
81.7	81.7	81.7	HYDRANT & VALVE 50" DIA.	81.70	0+620
81.7	81.7	81.7	HYDRANT & VALVE 50" DIA.	81.70	0+600
81.7	81.7	81.7	HYDRANT & VALVE 50" DIA.	81.70	0+580
81.7	81.7	81.7	HYDRANT & VALVE 50" DIA.	81.70	0+560
81.7	81.7	81.7	HYDRANT & VALVE 50" DIA.	81.70	0+540
81.7	81.7	81.7	HYDRANT & VALVE 50" DIA.	81.70	0+520
81.7	81.7	81.7	HYDRANT & VALVE 50" DIA.	81.70	0+500
81.7	81.7	81.7	HYDRANT & VALVE 50" DIA.	81.70	0+480
81.7	81.7	81.7	HYDRANT & VALVE 50" DIA.	81.70	0+460
81.7	81.7	81.7	HYDRANT & VALVE 50" DIA.	81.70	0+440
81.7	81.7	81.7	HYDRANT & VALVE 50" DIA.	81.70	0+420
81.7	81.7	81.7	HYDRANT & VALVE 50" DIA.	81.70	0+400
81.7	81.7	81.7	HYDRANT & VALVE 50" DIA.	81.70	0+380
81.7	81.7	81.7	HYDRANT & VALVE 50" DIA.	81.70	0+360
81.7	81.7	81.7	HYDRANT & VALVE 50" DIA.	81.70	0+340
81.7	81.7	81.7	HYDRANT & VALVE 50" DIA.	81.70	0+320
81.7	81.7	81.7	HYDRANT & VALVE 50" DIA.	81.70	0+300
81.7	81.7	81.7	HYDRANT & VALVE 50" DIA.	81.70	0+280
81.7	81.7	81.7	HYDRANT & VALVE 50" DIA.	81.70	0+260
81.7	81.7	81.7	HYDRANT & VALVE 50" DIA.	81.70	0+240
81.7	81.7	81.7	HYDRANT & VALVE 50" DIA.	81.70	0+220
81.7	81.7	81.7	HYDRANT & VALVE 50" DIA.	81.70	0+200
81.7	81.7	81.7	HYDRANT & VALVE 50" DIA.	81.70	0+180
81.7	81.7	81.7	HYDRANT & VALVE 50" DIA.	81.70	0+160
81.7	81.7	81.7	HYDRANT & VALVE 50" DIA.	81.70	0+140
81.7	81.7	81.7	HYDRANT & VALVE 50" DIA.	81.70	0+120
81.7	81.7	81.7	HYDRANT & VALVE 50" DIA.	81.70	0+100
81.7	81.7	81.7	HYDRANT & VALVE 50" DIA.	81.70	0+080
81.7	81.7	81.7	HYDRANT & VALVE 50" DIA.	81.70	0+060
81.7	81.7	81.7	HYDRANT & VALVE 50" DIA.	81.70	0+040
81.7	81.7	81.7	HYDRANT & VALVE 50" DIA.	81.70	0+020
81.7	81.7	81.7	HYDRANT & VALVE 50" DIA.	81.70	0+000

Design And Construction Division

C. Sim P. Eng. D.K. Donaldson P. Eng.

ROAD AND SITE SERVICES
ST. LAURENT BUSINESS PARK - PHASE II
ST. LAURENT BLVD (EXTENSION)
FROM STREET 'B' TO STATION 1+050

Contract No: 89-53 Survey Books: MOR, 1-500
Scale: VERT. 1-50
Sheet: 2304 of 8

APPENDIX I
Boundary Conditions

Guillaume Courtois

From: Baker, Adam <adam.baker@ottawa.ca>
Sent: December-13-17 9:18 AM
To: Guillaume Courtois
Cc: Oram, Cody
Subject: 2375 St-Laurent - Water Boundary Conditions
Attachments: 2375 St-Laurent Dec 2017.pdf

Follow Up Flag: Follow up
Flag Status: Flagged

Hi Guillaume,

Please find attached the boundary conditions requested for 2375 St-Laurent Blvd:

The following are boundary conditions, HGL, for hydraulic analysis at 2375 St-Laurent (zone 2C) assumed to be connected to the 305mm on St-Laurent (see attached PDF for location).

Minimum HGL = 124.5m

Maximum HGL = 130.6m

Max Day + Fire Flow (150 L/s) = 124.0m

These are for current conditions and are based on computer model simulation.

Disclaimer: The boundary condition information is based on current operation of the city water distribution system. The computer model simulation is based on the best information available at the time. The operation of the water distribution system can change on a regular basis, resulting in a variation in boundary conditions. The physical properties of watermains deteriorate over time, as such must be assumed in the absence of actual field test data. The variation in physical watermain properties can therefore alter the results of the computer model simulation.

If you have any questions, let me know.

Thanks,

Adam Baker, E.I.T.

Engineering Intern

Planning, Infrastructure and Economic Development Department - Services de la planification, de l'infrastructure et du développement économique

Development Review - South Branch

City of Ottawa | Ville d'Ottawa

110 Laurier Avenue West Ottawa, ON | 110, avenue. Laurier Ouest. Ottawa (Ontario) K1P 1J1

613.580.2424 ext./poste 26552, Adam.Baker@ottawa.ca

APPENDIX J
Overland Ponding Volume Table

Overland Ponding Volume Report

Generated: 2017-12-07 14:40:49
By user: gcourtois
Drawing: W:\FILES 2017\170721\06 CivilDesign\Drawings\LRL Civil Plans\W:\FILES 2017\170721\06 CivilDesign\Drawings\LRL Civil Plans\170721-02.dwg

Volume Summary							
Name	Type	Cut Factor	Fill Factor	2d Area (hectares)	Cut (Cu. M.)	Fill (Cu. M.)	Net (Cu. M.)
CBMH1 PONDING VOLUME HWL83.47	full	1.00	1.00	0.02	0.00	15.90	15.90<Fill>
CBMH2 PONDING VOLUME HWL83.47	full	1.00	1.00	0.02	0.00	14.87	14.86<Fill>
CBMH3 PONDING VOLUME HWL83.47	full	1.00	1.00	0.01	0.00	6.83	6.83<Fill>
CBMH4 PONDING VOLUME HWL83.47	full	1.00	1.00	0.02	0.00	11.27	11.27<Fill>
CBMH5 PONDING VOLUME HWL83.47	full	1.00	1.00	0.02	0.00	13.91	13.91<Fill>
Totals							
				2d Area (hectares)	Cut (Cu. M.)	Fill (Cu. M.)	Net (Cu. M.)
Total				0.09	0.01	62.78	62.78<Fill>

* Value adjusted by cut or fill factor other than 1.0