

LEGEND

	PROPOSED SPOT ELEVATION		PROPOSED HEAVY DUTY ASPHALT
	PROPOSED TOP OF CURB ELEVATION		PROPERTY LINE
	PROPOSED BOTTOM OF WALL ELEVATION		PROPOSED SAW CUT
	PROPOSED TOP OF WALL ELEVATION		PROPOSED BUILDING ENTRANCE
	PROPOSED TOP OF LID ELEVATION		MAJOR SYSTEM FLOW ROUTE
	EXISTING SPOT ELEVATION		MAX PONDING AREA
	PROPOSED GRADE AND DIRECTION		LIMIT OF CONSTRUCTION WORKS
	EXISTING GRADE AND DIRECTION		PROPOSED LANDSCAPE AREA
	PROPOSED/EXISTING SPOT ELEVATION		
	PROPOSED CATCH BASIN		
	PROPOSED CATCH BASIN MAINTENANCE HOLE		
	PROPOSED MAINTENANCE HOLE		
	PROPOSED SANITARY SEWER		

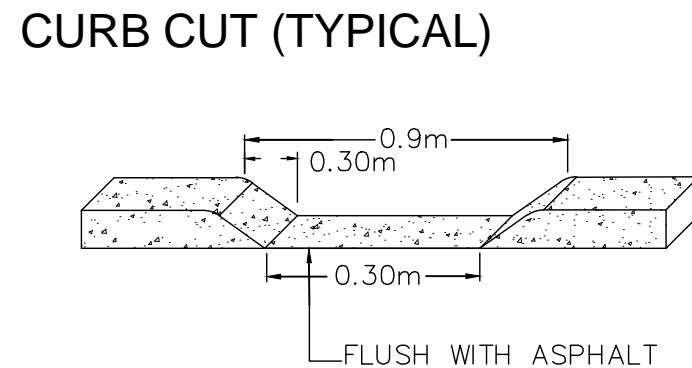

- GENERAL NOTES**
- ALL WORKS AND MATERIALS SHALL CONFORM TO THE LATEST REVISION OF THE STANDARDS AND SPECIFICATIONS FOR THE CITY OF OTTAWA, ONTARIO PROVINCIAL STANDARD DRAWINGS (OPSD) AND SPECIFICATIONS (OPSS), WHERE APPLICABLE. LOCAL UTILITY STANDARDS AND MINISTRY OF TRANSPORTATION STANDARDS WILL APPLY WHERE REQUIRED.
 - THE CONTRACTOR SHALL CONFIRM THE LOCATION OF ALL EXISTING UTILITIES WITHIN THE SITE AND ADJACENT WORK AREAS. THE CONTRACTOR SHALL BE RESPONSIBLE FOR PROTECTING ALL EXISTING UTILITIES TO THE SATISFACTION OF THE AUTHORITY HAVING JURISDICTION. THE CONTRACTOR SHALL BE RESPONSIBLE FOR THE REPAIR OR REPLACEMENT OF ANY SERVICES OR UTILITIES DISTURBED DURING CONSTRUCTION, TO THE SATISFACTION OF THE AUTHORITY HAVING JURISDICTION.
 - ALL DIMENSIONS SHALL BE CHECKED AND VERIFIED IN THE FIELD BY THE CONTRACTOR PRIOR TO THE START OF CONSTRUCTION. ANY DISCREPANCIES SHALL BE REPORTED IMMEDIATELY TO THE ENGINEER. LOST THE DUE TO FAILURE OF THE CONTRACTOR TO CONFIRM UTILITY LOCATIONS AND NOTIFY ENGINEER OF POSSIBLE CONFLICTS PRIOR TO CONSTRUCTION WILL BE AT THE CONTRACTOR'S EXPENSE.
 - ANY AREAS BEYOND THE LIMIT OF THE SITE DISTURBED DURING CONSTRUCTION SHALL BE RESTORED TO ORIGINAL CONDITION OR BETTER TO THE SATISFACTION OF THE AUTHORITY HAVING JURISDICTION AT THE CONTRACTOR'S EXPENSE.
 - RELOCATION OF EXISTING SERVICES AND/OR UTILITIES SHALL BE AS SHOWN ON THE DRAWINGS OR DIRECTED BY THE ENGINEER AT THE EXPENSE OF THE DEVELOPER.
 - ALL WORK SHALL BE COMPLETED IN ACCORDANCE WITH THE "OCCUPATIONAL HEALTH AND SAFETY ACT AND REGULATIONS FOR CONSTRUCTION PROJECTS". THE GENERAL CONTRACTOR SHALL BE DEEMED TO BE THE "CONTRACTOR" AS DEFINED IN THE ACT.
 - ALL CONSTRUCTION SIGNAGE MUST CONFORM TO THE MINISTRY OF TRANSPORTATION OF ONTARIO MANUAL OF UNIFORM TRAFFIC CONTROL DEVICES PER LATEST AMENDMENT.
 - THE CONTRACTOR IS ADVISED THAT WORKS BY OTHERS MAY BE ONGOING DURING THE PERIOD OF THIS CONTRACT. THE CONTRACTOR SHALL COORDINATE CONSTRUCTION ACTIVITIES TO PREVENT CONFLICTS.
 - ALL DIMENSIONS ARE IN METRES UNLESS SPECIFIED OTHERWISE.
 - THERE WILL BE NO SUBSTITUTION OF MATERIALS UNLESS PRIOR WRITTEN APPROVAL IS RECEIVED FROM THE ENGINEER.
 - ALL CONSTRUCTION SHALL BE CARRIED OUT IN ACCORDANCE WITH THE RECOMMENDATIONS MADE IN THE GEOTECHNICAL REPORT.
 - FOR DETAILS RELATING TO STORMWATER MANAGEMENT AND ROOF DRAINAGE REFER TO THE SITE SERVICING AND STORMWATER MANAGEMENT REPORT.
 - ALL SEWERS CONSTRUCTED WITH GRADES LESS THAN 1.0% SHALL BE INSTALLED USING LASER ALIGNMENT AND CHECKED WITH LEVEL INSTRUMENT PRIOR TO BACKFILLING.
 - THE CONTRACTOR IS RESPONSIBLE FOR OBTAINING ALL PERMITS REQUIRED AND TO BEAR THE COST OF THE SAME.
 - THE CONTRACTOR WILL BE RESPONSIBLE FOR ADDITIONAL BEDDING, OR ADDITIONAL STRENGTH PIPE IF THE MAXIMUM TRENCH WIDTH AS SPECIFIED BY OPSS IS EXCEEDED.
 - ALL PIPE / CULVERT SECTION SIZES REFER TO INSIDE DIMENSIONS.
 - SHOULD DEEPLY BURIED ARCHAEOLOGICAL REMAINS BE FOUND ON THE PROPERTY DURING CONSTRUCTION ACTIVITIES, THE HERITAGE OPERATIONS UNIT OF THE ONTARIO MINISTRY OF CULTURE MUST BE NOTIFIED IMMEDIATELY.
 - ALL NECESSARY CLEARING AND GRUBBING SHALL BE COMPLETED BY THE CONTRACTOR. REVIEW WITH CONTRACT ADMINISTRATOR AND THE CITY OF OTTAWA PRIOR TO ANY CUTTING / REMOVAL.
 - DRAWINGS SHALL BE READ IN CONJUNCTION WITH THE ARCHITECTURAL SITE PLAN.
 - THE CONTRACTOR SHALL PROVIDE THE PROJECT ENGINEER ONE SET OF AS CONSTRUCTED SITE SERVICING AND GRADING DRAWINGS.
 - BENCHMARKS: IT IS THE RESPONSIBILITY OF THE CONTRACTOR TO VERIFY THAT THE SITE BENCHMARK(S) HAS NOT BEEN ALTERED OR DISTURBED AND THAT ITS RELATIVE ELEVATION AND DESCRIPTION AGREES WITH THE INFORMATION DEPICTED ON THIS PLAN.

- SITE GRADING NOTES**
- PRIOR TO THE COMMENCEMENT OF THE SITE GRADING WORKS, ALL SILTATION CONTROL DEVICES SHALL BE INSTALLED AND OPERATIONAL PER EROSION CONTROL PLAN.
 - ALL GRANULAR AND PAVEMENT FOR ROADS/PARKING AREAS SHALL BE CONSTRUCTED IN ACCORDANCE WITH GEOTECHNICAL ENGINEER'S RECOMMENDATIONS.
 - ALL TOPSOIL AND ORGANIC MATERIAL SHALL BE STRIPPED WITHIN THE ROAD AND PARKING AREAS ALLOWANCE PRIOR TO THE COMMENCEMENT OF CONSTRUCTION.
 - CONCRETE CURBS SHALL BE IN ACCORDANCE WITH CITY OF OTTAWA STD. SC1.1. PROVISION SHALL BE MADE FOR CURB DEPRESSIONS AS INDICATED ON ARCHITECTURAL SITE PLAN. CONCRETE SIDEWALK SHALL BE IN ACCORDANCE WITH CITY OF OTTAWA STD. SC1.4. ALL CURBS, CONCRETE ISLANDS, AND SIDEWALKS SHOWN ON THIS DRAWING ARE TO BE PRICED IN THE SITEMARKS PORTION OF THE CONTRACT.
 - PAVEMENT REINSTATEMENT FOR SERVICE AND UTILITY CUTS SHALL BE IN ACCORDANCE WITH THE CITY OF OTTAWA STD. R10 AND OPSS 509.010, AND OPSS 310.
 - GRANULAR 'A' SHALL BE PLACED TO A MINIMUM THICKNESS OF 300mm AROUND ALL STRUCTURES WITHIN THE PAVEMENT AREA.
 - SUB-EXCAVATE SOFT AREAS AND FILL WITH GRANULAR 'B' COMPACTED IN MAXIMUM 300mm LIFTS.
 - ALL WORK ON THE MUNICIPAL RIGHT OF WAY AND EASEMENTS TO BE INSPECTED BY THE MUNICIPALITY PRIOR TO BACKFILLING.
 - CONTRACTOR TO OBTAIN A ROAD OCCUPANCY PERMIT 48 HOURS PRIOR TO COMMENCING ANY WORK WITHIN THE MUNICIPAL ROAD ALLOWANCE, IF REQUIRED BY THE MUNICIPALITY.
 - ALL PAVEMENT MARKING FEATURES AND SITE SIGNAGE SHALL BE PLACED PER ARCHITECTURAL SITE PLAN. LINE PAINTING AND DIRECTIONAL SYMBOLS SHALL BE APPLIED WITH MINIMUM OF TWO COATS OF ORGANIC SOLVENT PAINT.
 - REFER TO ARCHITECTURAL SITE PLAN FOR DIMENSIONS AND SITE DETAILS.
 - STEP JOINTS ARE TO BE USED WHERE PROPOSED ASPHALT MEETS EXISTING ASPHALT. ALL JOINTS MUST BE SEALED.
 - SIDEWALKS TO BE 20mm BELOW THE FINISHED FLOOR SLAB ELEVATION AT ENTRANCES UNLESS OTHERWISE NOTED.
 - WHERE APPLICABLE THE CONTRACTOR IS TO SUBMIT SHOP DRAWS FOR RETAINING WALL (INCLUDE RAILINGS IF APPLICABLE) TO THE ENGINEER FOR APPROVAL PRIOR TO CONSTRUCTION. SHOP DRAWS MUST BE SITE SPECIFIC, SHOWN SEALED BY A LICENSED STRUCTURAL ENGINEER. THE CONTRACTOR WILL ALSO BE REQUIRED TO SUPPLY STRUCTURAL AND GEOTECHNICAL CERTIFICATION OF THE AS-CONSTRUCTED RETAINING WALL TO THE ENGINEER PRIOR TO FINAL ACCEPTANCE.

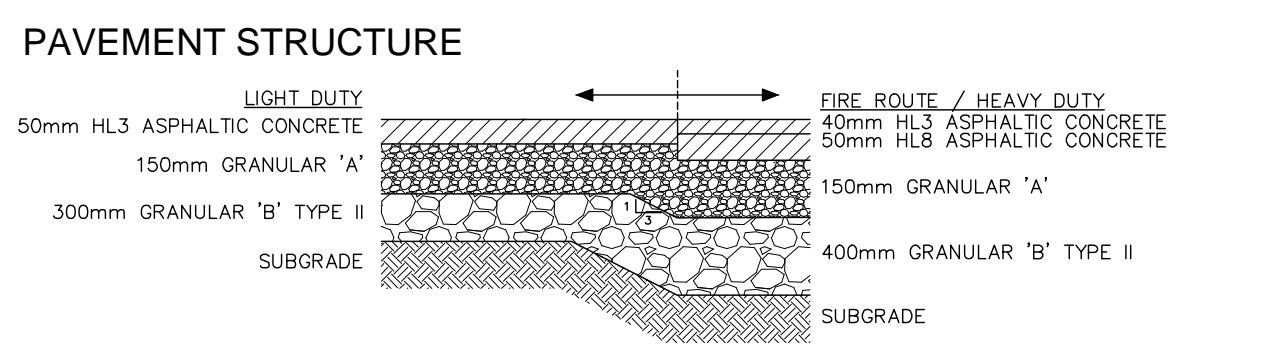

NOT FOR CONSTRUCTION

TOPOGRAPHIC INFORMATION
 TOPOGRAPHIC INFORMATION PROVIDED BY FAIRHALL MOFFATT AND WOODLAND LIMITED
 PROJ. NO. 117700
 DATE RECEIVED APRIL 11, 2017

SITE PLAN INFORMATION
 SITE PLAN PROVIDED BY FOTENI PLANNING AND DESIGN
 PROJ. NO. 17-914
 DATED APRIL 17, 2017

GEOTECHNICAL STUDY
 GEOTECHNICAL RECOMMENDATIONS PROVIDED BY PATERSON GROUP INC.
 PROJ. NO. PG3167-1
 DATED FEBRUARY 14, 2014

SITE SERVICING AND STORMWATER MANAGEMENT STUDY
 SERVICING AND STORMWATER MANAGEMENT RECOMMENDATIONS PROVIDED BY DSEL
 PROJ. NO. 17-914
 DATED NOVEMBER 2014 (AMENDED APRIL 2017)

BENCH MARK
 TOP OF MOST WESTERN BOLT ON TRAFFIC LIGHT LOCATED AT THE WEST CORNER OF BURRIS LANE AND MERIVALE ROAD
 BENCHMARK ELEVATION=96.12

No.	BY	YY.MM.DD	DESCRIPTION
1	S.L.M.	17.04.19	ISSUED FOR MUNICIPAL REVIEW

PROJECT No. 17-914

GRADING PLAN
 1450 & 1454 MERIVALE ROAD © DSEL

2620, rue de Salaberry
 MONTREAL, QC H3M 1L3

First Capital Asset Management ULC

DSEL
 david schaeffer engineering ltd
 SMART SUBDIVISIONS™

120 Iber Road Unit 203
 Stittsville, Ontario, K2S 1E9
 Tel. (613) 836-0856
 Fax. (613) 836-7183
 www.DSEL.ca

DRAWN BY:	B.N.C.	CHECKED BY:	A.D.F.	DRAWING NO.	SHEET NO.
DESIGNED BY:	B.N.C.	CHECKED BY:	A.D.F.	GP-1	2 of 4
SCALE:	1:300	DATE:	APRIL 2017		