

1 POOL HOUSE FLOOR PLAN
SCALE: 3/16" = 1'-0"

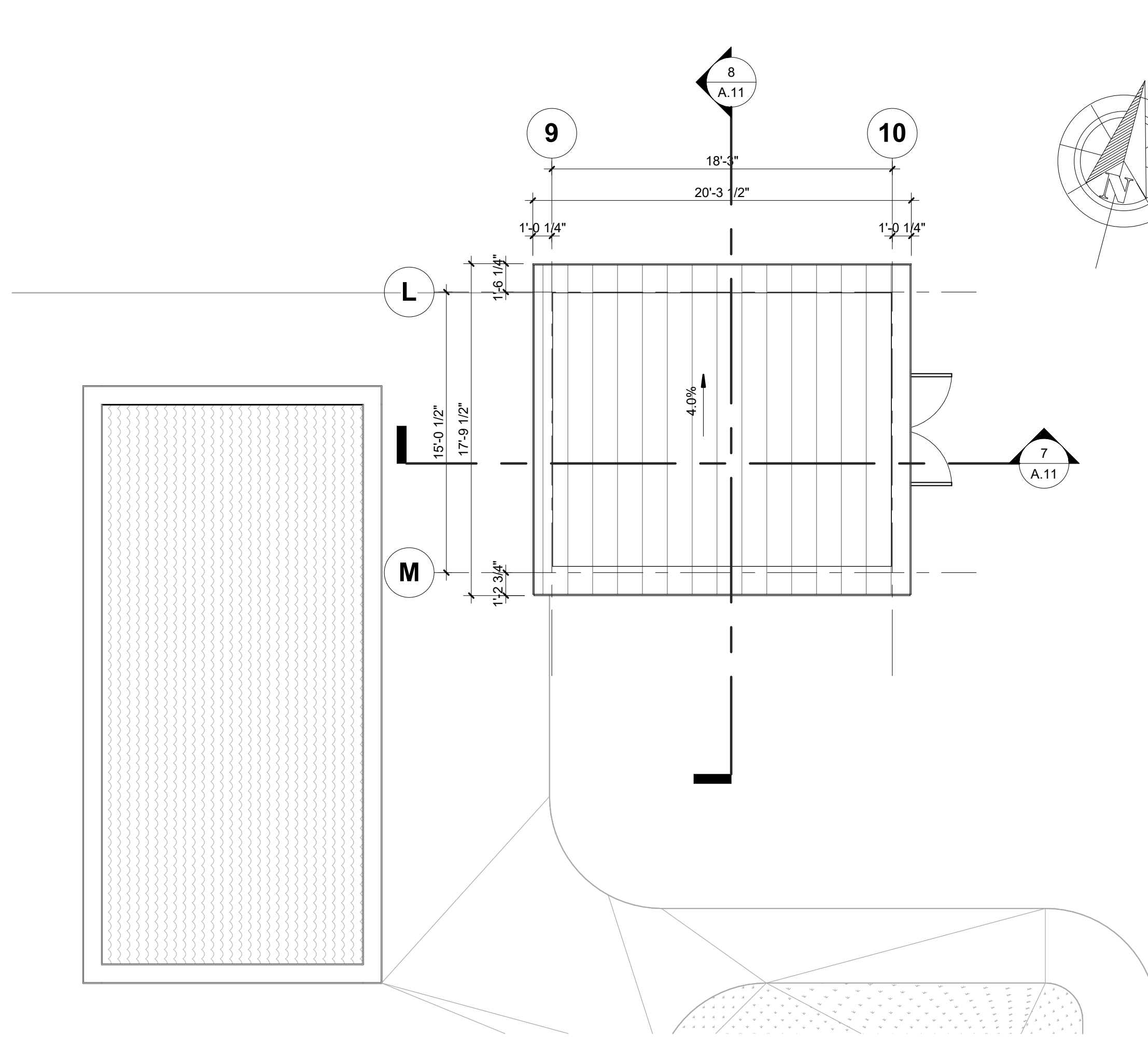

6 POOL HOUSE ROOF PLAN
SCALE: 3/16" = 1'-0"

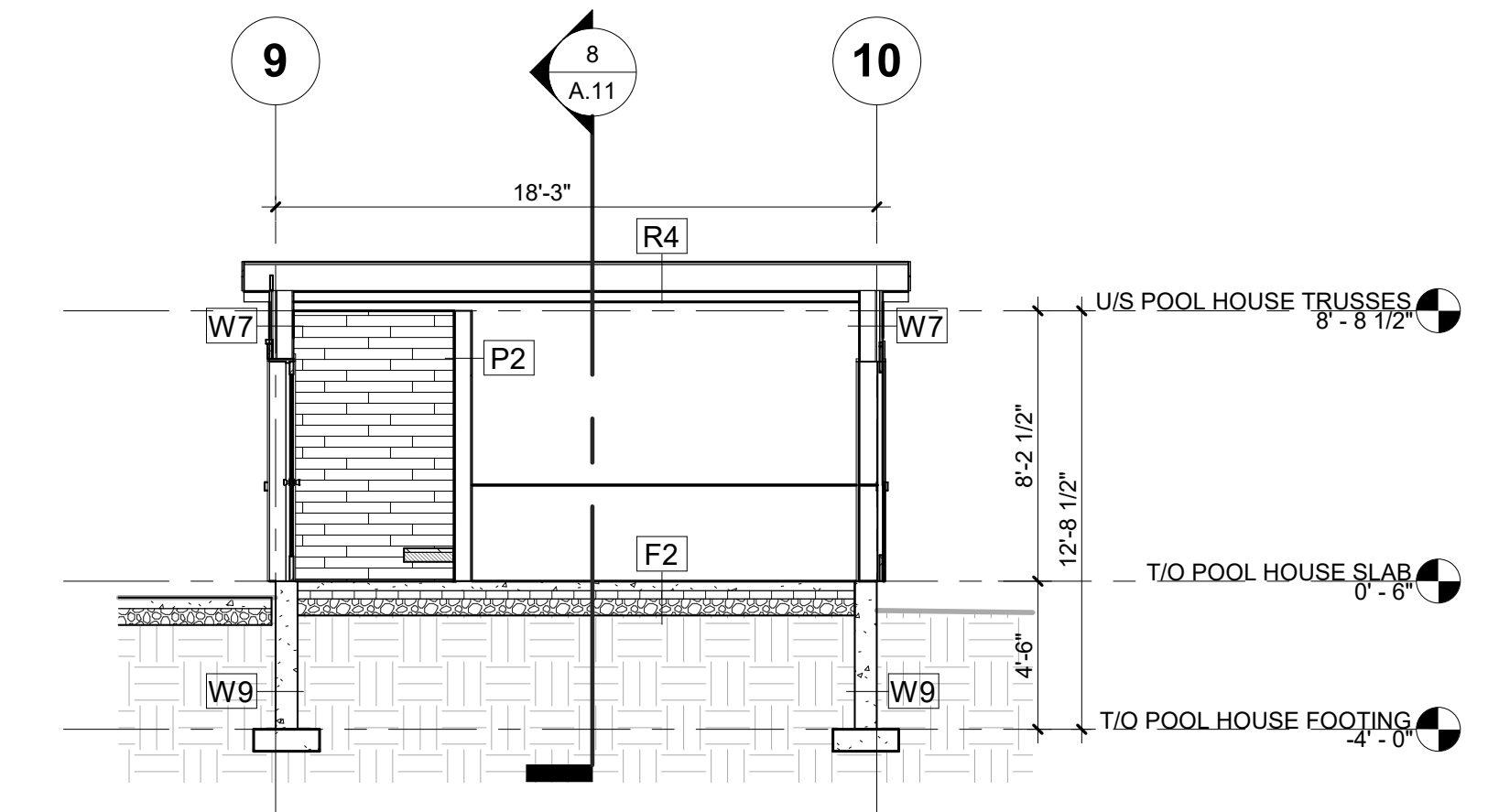

7 POOLHOUSE SECTION
SCALE: 3/16" = 1'-0"

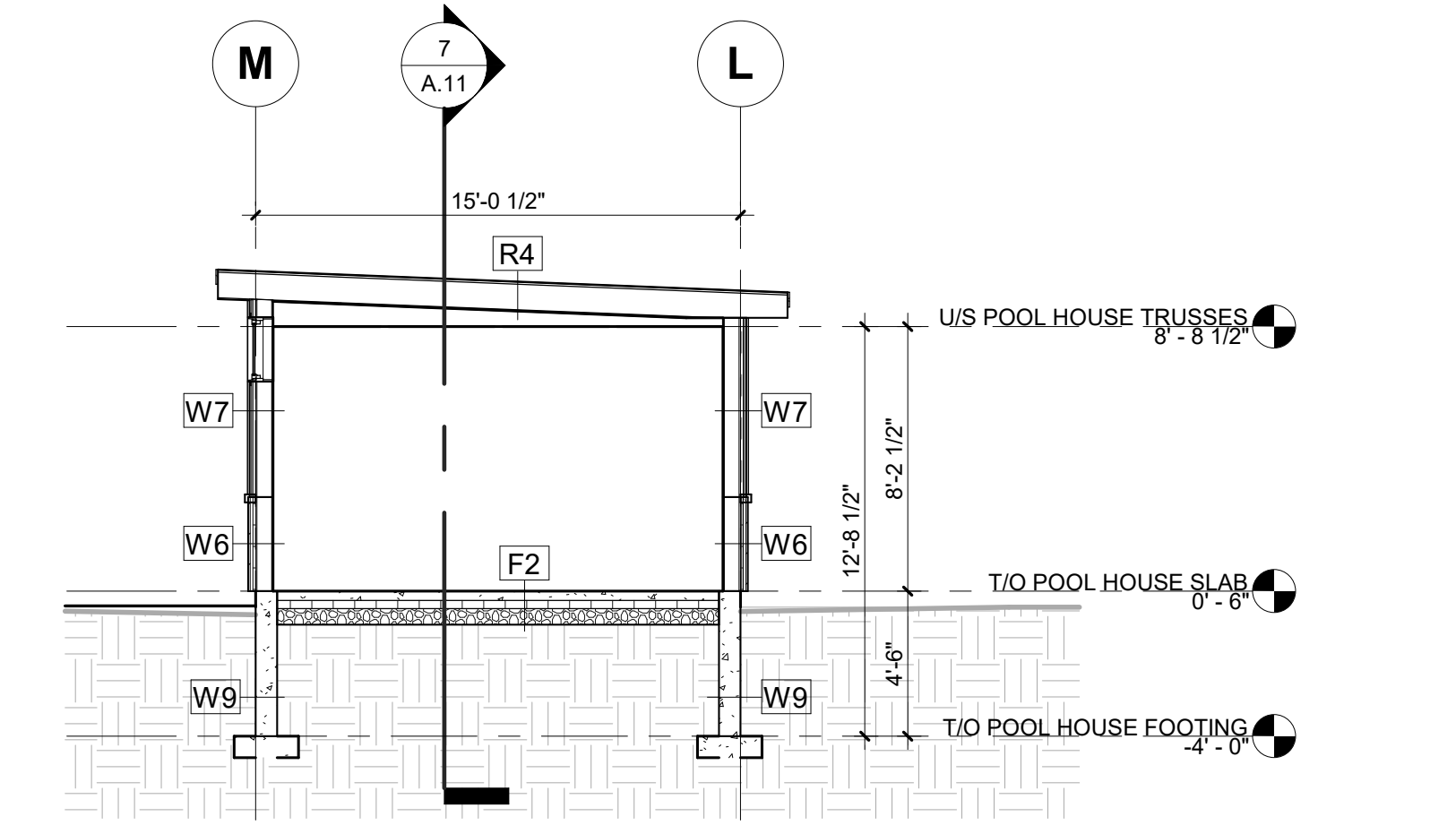

8 POOLHOUSE SECTION 2
SCALE: 3/16" = 1'-0"

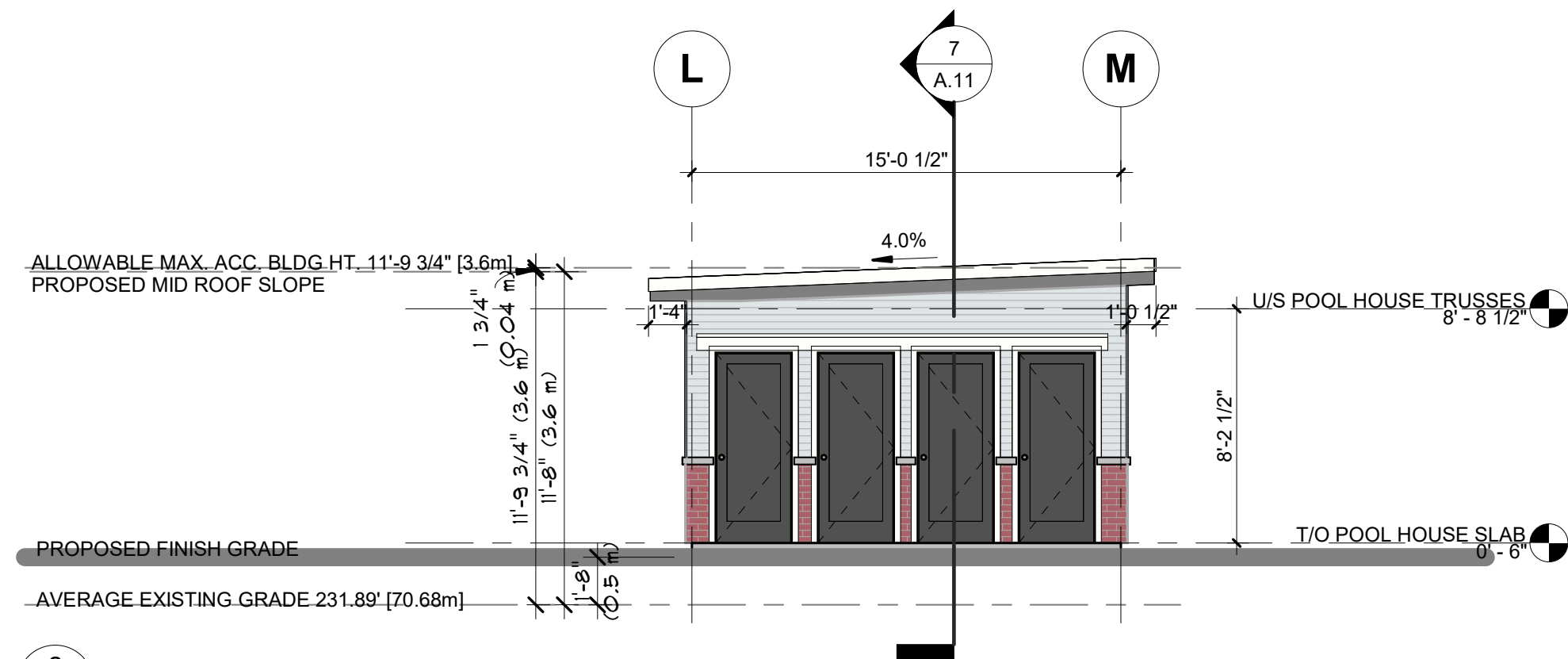

2 FRONT POOL HOUSE ELEV.
SCALE: 3/16" = 1'-0"

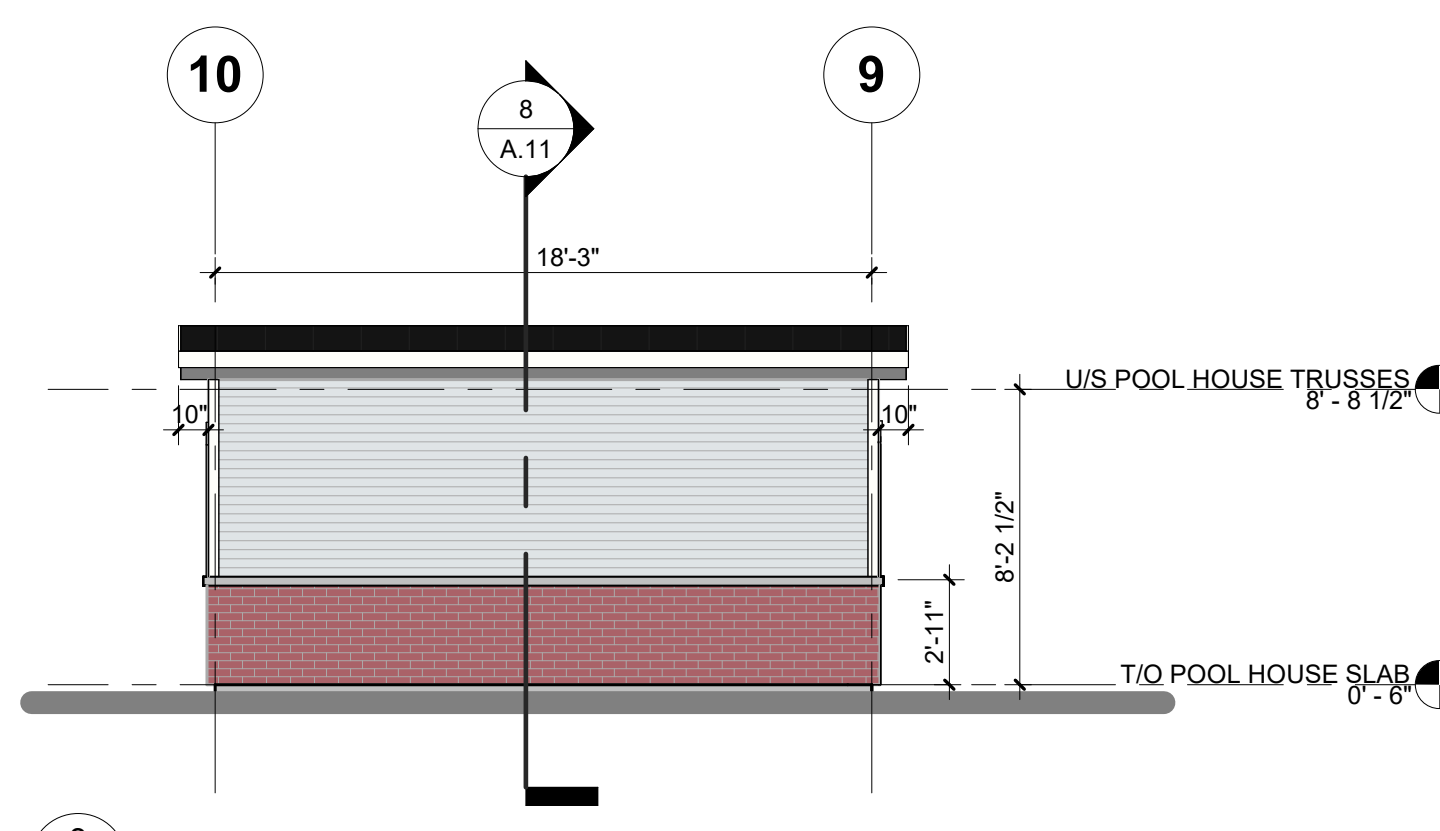

3 LEFT POOL HOUSE ELEV.
SCALE: 3/16" = 1'-0"

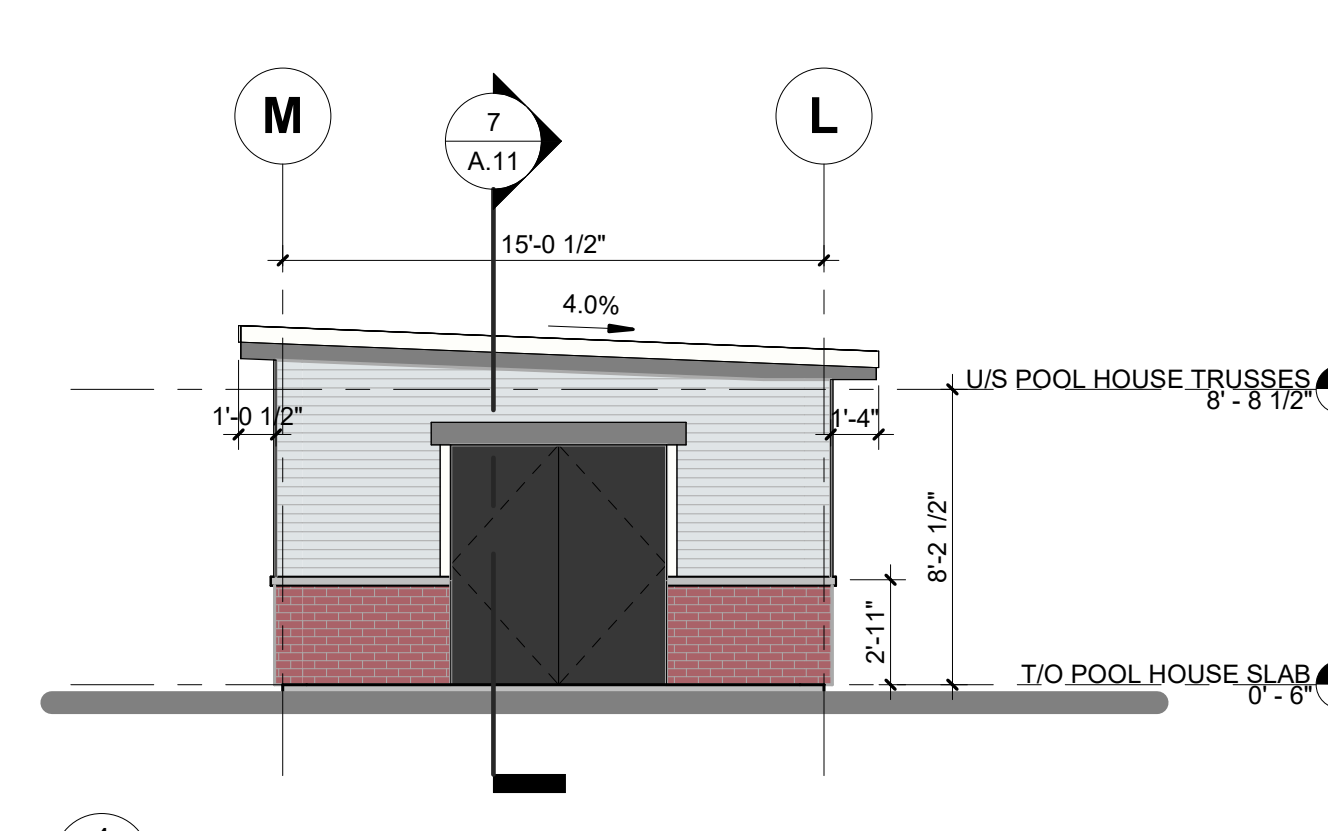

4 REAR POOL HOUSE ELEV.
SCALE: 3/16" = 1'-0"

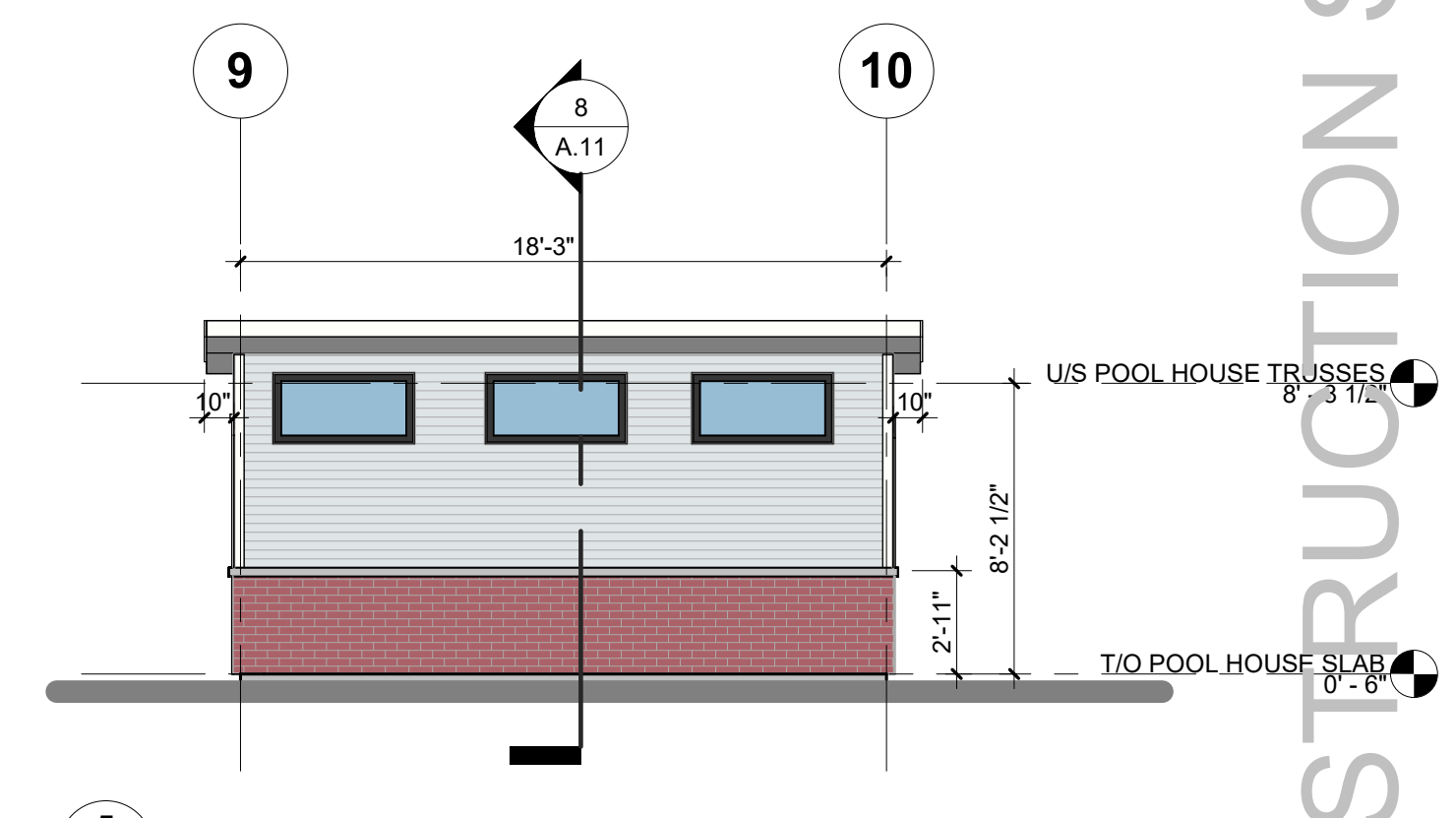

5 RIGHT POOL HOUSE ELEV.
SCALE: 3/16" = 1'-0"

AVERAGE EXISTING GRADE CALCULATION (POOL HOUSE): (EXISTING GRADE POINTS AT PERIMETER OF POOL HOUSE, SEE SITE PLAN) 231.92 [70.69m] 231.92 [70.69m] 231.79 [70.65m] 231.92 [70.69m] 927.65 [282.72m] / 4 = 231.89 [70.68m] AVERAGE EXISTING GRADE	MAX. BUILDING HEIGHT CALCULATION (POOL HOUSE): 231.89 [70.68m] [AVERAGE EXISTING GRADE] + 11'-9 3/4" [3.6m] =243.70' [74.28m] MAX. BUILDING HEIGHT
---	---

NOTES:
REFER TO GENERAL NOTES FOR ALL TYPICAL CONSTRUCTION NOTES
A DETAILS WHEN DRAWINGS OR NOTES REFERENCE D.C. IN ALL
CASES PLEASE REFER TO THE LATEST VERSION OF THE ONTARIO
BUILDING CODE 2012.

①	EXTERIOR DOOR & WINDOW TAG (SEE SCHEDULE ON A.0.a)
②	DOOR TAG (SEE SCHEDULE ON A.0.a)
W1	EXTERIOR WALL TYPE (SEE A.0.a)
P1	INTERIOR PARTITION WALL TYPE (SEE A.0.a)
F1	FLOOR TYPE (SEE A.0.a)
R1	ROOF TYPE (SEE A.0.a)
P1	POST TYPE (SEE A.0.a)
F1	PAD FOOTING TYPE (SEE A.0.a)
WF1	WALL FOOTING TYPE (SEE A.0.a)

Legend Cont:	SMOKE/CARBON DETECTOR TO O.B.C. 9.10.19
--------------	---

BELL
+ ASSOCIATES
ARCHITECTURE

• A 134 John Street
Port Hope, ON, K9A 1H7
613-279-0988
• 101-3108 Carp Road
Cobourg, ON, K9J 1G3
613-831-9688
• info@bell.ca
bellarchitecture.ca

VERSION NO.	13
DATE	05/22
SEAL:	

NOTES:
ALL CONSTRUCTION SHALL COMPLY WITH ALL CODES & REGULATIONS APPLICABLE TO THE PROJECT.
IT IS THE RESPONSIBILITY OF THE APPROVED CONTRACTOR TO OBTAIN A COPY OF ALL
APPLICABLE CODES & REGULATIONS AND TO ENSURE THAT ALL WORK IS IN ACCORDANCE WITH
THE SAME.
DO NOT SCALE DRAWINGS.
CONTRACTOR SHALL BE RESPONSIBLE FOR OBTAINING ALL NECESSARY PERMITS FOR CONSTRUCTION.
CONTRACTOR SHALL BE RESPONSIBLE FOR OBTAINING ALL NECESSARY INSURANCE COVERAGE.
CONTRACTOR SHALL BE RESPONSIBLE FOR OBTAINING ALL NECESSARY UTILITIES INFORMATION.
CONTRACTOR SHALL BE RESPONSIBLE FOR OBTAINING ALL NECESSARY EROSION CONTROL MEASURES.
CONTRACTOR SHALL BE RESPONSIBLE FOR OBTAINING ALL NECESSARY TRAFFIC CONTROL MEASURES.
CONTRACTOR SHALL BE RESPONSIBLE FOR OBTAINING ALL NECESSARY NEIGHBORHOOD NOTICES.
CONTRACTOR SHALL BE RESPONSIBLE FOR OBTAINING ALL NECESSARY ADJACENT PROPERTY NOTICES.
CONTRACTOR SHALL BE RESPONSIBLE FOR OBTAINING ALL NECESSARY PUBLIC WORKS NOTICES.
CONTRACTOR SHALL BE RESPONSIBLE FOR OBTAINING ALL NECESSARY UTILITIES CROSSING AGREEMENTS.
CONTRACTOR SHALL BE RESPONSIBLE FOR OBTAINING ALL NECESSARY EROSION CONTROL MEASURES.
CONTRACTOR SHALL BE RESPONSIBLE FOR OBTAINING ALL NECESSARY TRAFFIC CONTROL MEASURES.
CONTRACTOR SHALL BE RESPONSIBLE FOR OBTAINING ALL NECESSARY NEIGHBORHOOD NOTICES.
CONTRACTOR SHALL BE RESPONSIBLE FOR OBTAINING ALL NECESSARY ADJACENT PROPERTY NOTICES.
CONTRACTOR SHALL BE RESPONSIBLE FOR OBTAINING ALL NECESSARY PUBLIC WORKS NOTICES.
CONTRACTOR SHALL BE RESPONSIBLE FOR OBTAINING ALL NECESSARY UTILITIES CROSSING AGREEMENTS.

NO.	ITEM	DATE
11	ISSUED FOR B.P.	02/17/22
12	COORDINATION	02/21/22
13	CONSTRUCTION SET	05/22/22

PROJECT	UGANDA HIGH COMMISSION
CLIENT	STITTVILLE, ONTARIO
DRAWING	POOL HOUSE DRAWINGS

SCALE	3/16" = 1'-0"
DRAWN BY	CB
DATE	AUG. 8, 2022
CHECKED BY	JB
APPROVED BY	JB
PROJECT NO.	219-35
SHEET NO.	A.11

CONSTRUCTION SET