



February 9, 2026

JB Holdings Inc.
107 Pretoria Avenue
Ottawa, ON K1S 1W8
Attn. John Bassi – President

RE: TREE CONSERVATION REPORT FOR 443 ECHO DRIVE, OTTAWA

This Tree Conservation Report (TCR) was prepared in support of a site plan application for 443 Echo Drive in Ottawa. The need for this TCR is related to the proposed redevelopment of the subject property which is presently occupied by a three-storey apartment building with surface parking. A multi-storey apartment building with underground parking is now proposed.

The need for a TCR is related to trees protected under the City of Ottawa’s Tree Protection By-law (By-law No. 2020-340). Under the By-law, a TCR is required for all plans of subdivision, site plan control applications, common elements condominium applications, and vacant land condominium applications where there is a tree of 10 cm in diameter at breast height (DBH) or greater on a site and/or if there is a tree on an adjacent site that has a critical root zone (CRZ) extending onto a development site. Trees of any size on adjacent City land must also be documented in a TCR. A “tree” is defined in the By-law as any species of woody perennial plant, including its root system, which has reached or can reach a minimum height of at least 450 cm at physiological maturity. The CRZ is calculated as DBH x 10 cm.

The approval of this TCR by the by the City’s General Manager and the issuing of a permit authorizes the removal of approved trees. *Importantly, although this report may be used to support the application for a city tree removal permit, it does not by itself constitute permission to remove trees or begin site clearing activities. No such work should occur before a tree removal permit is issued authorizing the injury or destruction of a tree in accordance with the By-law. Importantly, prior written permission from adjacent property owners is required for the removal of shared or neighbouring trees if they will be lost or terminally damaged by construction activities.*

The inventory in this report details the assessment of all individual trees on the subject and adjacent private property, including trees on nearby City of Ottawa property. Field work for this report was completed in January 2026.

TREE SPECIES, CONDITION, SIZE AND STATUS

Table 1 on pages 2 and 3 details the species, condition, size (diameter), ownership and preservation status of each individual tree. Each tree is referenced by the numbers plotted on the tree conservation plans on pages 6 and 7 of this report. Pictures 1 to 6 on pages 10 through 14 show the trees on and adjacent to the subject property.



Table 1. Species, size, critical root and static zones, distance to excavation, ownership and condition of trees at 443 Echo Drive

Tree No.	Tree species	DBH ¹ (cm)	CRZ ² & SRZ ³ (m)	Distance to excavation (m)	Owner-ship ⁴	Age class, tree condition & notes; species origin; preservation status (to be removed or preserved and protected)
1	Norway maple (<i>Acer platanoides</i>)	34.5	3.5 & 1.1	-	Shared with city	Mature; fair; central stem with competing laterals and suppressed laterals starting at 1.75m; west side of upper crown moderately pruned from Hydro lines; introduced invasive species; to be removed (conflicts with excavation for proposed underground parking)
2	Norway maple (<i>Acer platanoides</i>)	32.5	3.2 & 1	-	Shared with city	Mature; fair; co-dominant stems at 3m, stems divergent; west side of upper crown moderately pruned from Hydro lines; introduced invasive species; to be removed (conflicts with excavation for proposed underground parking)
3	Manitoba maple (<i>Acer negundo</i>)	+/-25	2.5 & 0.75	<1	Private/shared	Maturing; poor; growth form divergent towards northeast; currently damaging fence; naturalized species (originated from seed); to be removed (poor condition and will not survive projected root loss in relation to proposed walkway)
4	Austrian pine (<i>Pinus nigra</i>)	+/-30	+/-3 & 0.9	2	Neighbour	Mature; good; central stem with competing leaders at 5.5m; good crown density, annual increment and needle colour; introduced species; to be preserved and protected
5	Black walnut (<i>Juglans nigra</i>)	45	4.5 & 1.4	2	Private/shared	Mature; fair; central dominant stem with competing leaders near crown apex; crown asymmetric towards north and east due to influence of tree #6; native species; to be preserved and protected
6	Norway maple (<i>Acer platanoides</i>)	49 (at 1m)	4.9 & 1.5	2	Private/shared	Mature; poor; co-dominant stems at 1.2m with major inclusion ridge within union; southwest stem bisects at 2.5m, northeast at 4m; generally upright form; major deadwood; to be removed (poor condition and will not survive projected root loss in relation to excavation for proposed underground parking)

Table 1. Cont.

Tree No.	Tree species	DBH ¹ (cm)	CRZ ² & SRZ ³ (m)	Distance to excavation (m)	Ownership ⁴	Age class, tree condition & notes; species origin; preservation status (to be removed or preserved and protected)
7	Black walnut (<i>Juglans nigra</i>)	74	7.4 & 2.2	<2	Private/ shared	Very mature; fair; central pedestal with co-dominant stems at 6.5m; south stems bisects at 8.5m, west at 10.5m; major competing and suppressed laterals starting at 6.5m; lower crown asymmetric towards south and east due to influence of tree #6; native species; to be removed (will not survive projected root loss in relation to excavation for proposed underground parking)
8	Hackberry (<i>Celtis occidentalis</i>)	54.4	5.4 & 1.6	5	Neighbour/ city	Mature; poor; pedestal holding multiple competing and suppressed stems starting at 2m; heavily pruned from overhead Hydro lines; native species; to be preserved and protected

¹ Diameter at breast height, or 1.4m from grade (unless otherwise indicated) ² The critical root zone (CRZ) is established as being 10 centimetres from the trunk of a tree for every centimetre of trunk diameter at breast height (DBH). The CRZ is calculated as DBH x 10 cm. ³ The static root zone (SRZ) is three times the diameter of the tree and is considered the distance within which no roots should be cut. ⁴ Tree location/ownership taken from the topographic survey prepared by Annis, O'Sullivan, Vollebakk Ltd.

FEDERAL AND PROVINCIAL REGULATIONS

Federal and provincial regulations can be applicable to trees on private property. In particular, the following two regulations are relevant in relation to this property:

- 1) Endangered Species Act (2007): No butternuts (*Juglans cinerea*) or black ash (*Fraxinus nigra*) were identified on the subject or adjacent properties. These species of tree are listed as threatened under the Province of Ontario's Endangered Species Act (2007) and so are protected from harm.
- 2) Migratory Bird Convention Act (1994): In the period between April and August of each year nest surveys must be performed by a suitably trained person no more than three (3) days before trees or other similar nesting habitat are to be removed.

TREE PROTECTION MEASURES

Preservation and protection measures intended to mitigate damage during construction will be applied for the trees to be retained. The following measures are the minimum required by the City of Ottawa to ensure tree survival during and following construction:

1. As per the City of Ottawa's tree protection barrier specification (included on page 8), erect a fence as close as possible to the CRZ of the trees.
2. Do not place any material or equipment within the CRZ of the tree.
3. Do not attach any signs, notices or posters to any tree.
4. Do not raise or lower the existing grade within the CRZ without approval.
5. Tunnel or bore when digging within the CRZ of a tree.
6. Do not damage the root system, trunk or branches of any tree.
7. Ensure that exhaust fumes from all equipment are NOT directed towards any tree's crown.

TREE PRESERVATION MEASURES

As excavation occurs within the CRZs of trees #4, 5 and 8, the following measures will be taken:

1. Hydro excavation along the edge of excavation in proximity to the tree to carefully expose roots. Exposed roots will then be cleanly cut and sealed before being reburied (see City of Ottawa root pruning detail on page 9). Excavation can then resume using traditional mechanical means. Sealing the cleanly cut root ends with a beeswax product will help prevent the loss of moisture and facilitate healing.
2. If the excavation is to be left open for any length of time a covering of at least three layers of moistened burlap is to be draped over the exposed face of excavation closet to the tree. A final covering of clear or white plastic will help retain moisture within the burlap. The use of burlap and plastic coverings will help reduce the loss of moisture from the soil surrounding the remaining roots.

This report is subject to the attached Limitations of Tree Assessments to which the reader's attention is directed.

Please do not hesitate to contact the undersigned with any questions concerning this report.

Yours,



Andrew K. Boyd, B.Sc.F, R.P.F. (#1828)
Certified Arborist #ON-0496A
Consulting Urban Forester

GENERAL NOTES

PLANS COMPLETED BY PROJECT STUDIO1 (02/12/25)

LEGEND

- TREE TO REMAIN
- CRITICAL ROOT ZONE
- PROTECTIVE FENCING
- TREE TO BE REMOVED
- CRITICAL ROOT ZONE

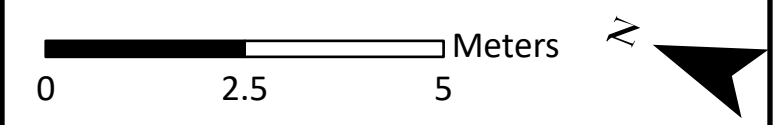

DRAWING: Tree Conservation Plan

PROJECT: 443 ECHO DRIVE
CITY OF OTTAWA



613-850-2475

Andrew K. Boyd, R.P.F.

SCALE:	1:95	4 4 3 E
DATE:	2026-02-05	
DRAWN BY:	SS	
SHEET NO.:	1	

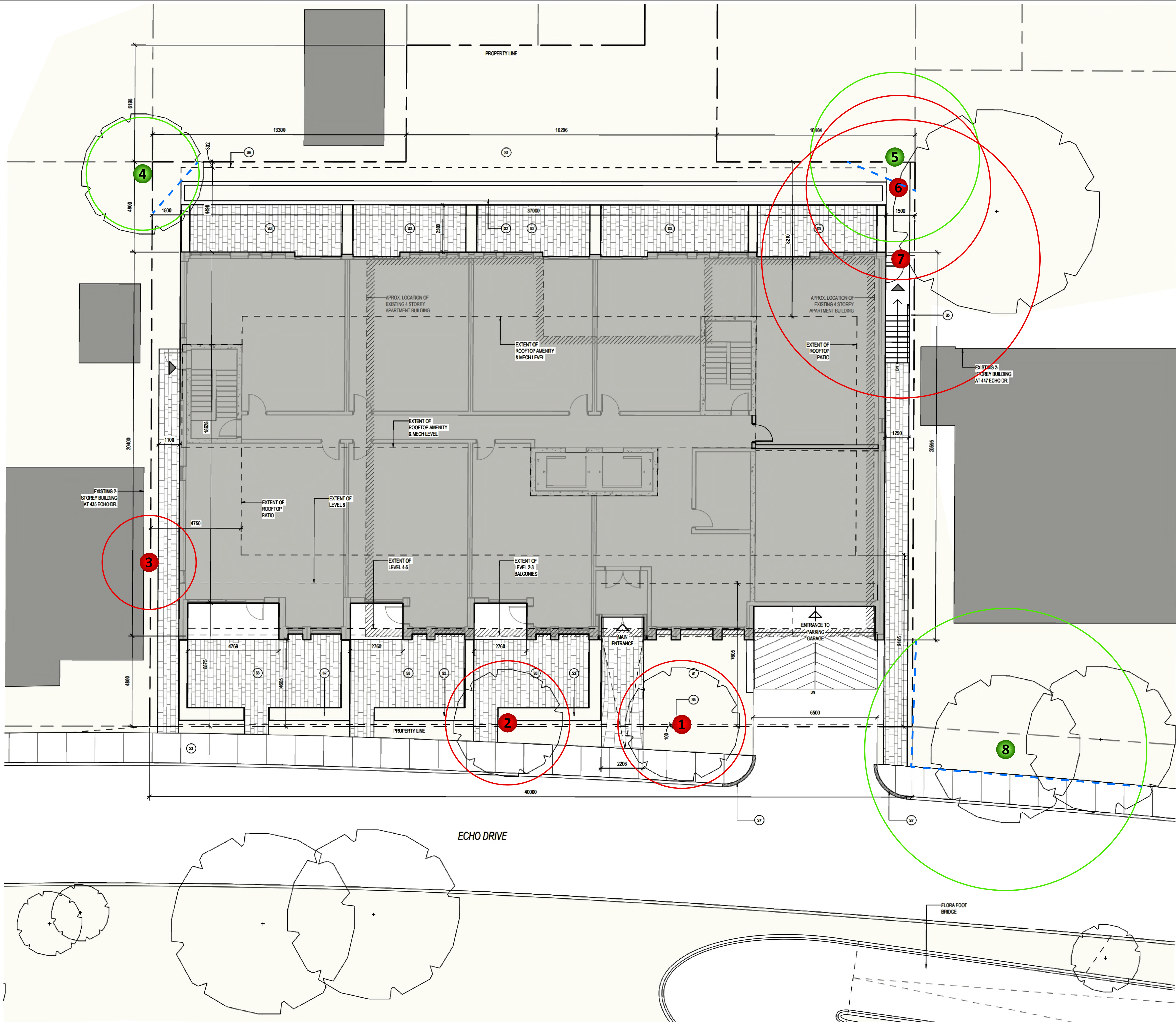



GENERAL NOTES

Microsoft, Vantor

LEGEND

- TREE TO REMAIN
- CRITICAL ROOT ZONE
- PROTECTIVE FENCING
- TREE TO BE REMOVED
- CRITICAL ROOT ZONE

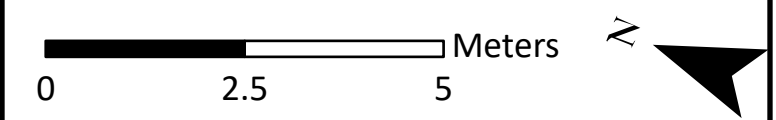

DRAWING:
Tree Conservation Plan

PROJECT:
443 ECHO DRIVE
CITY OF OTTAWA



Andrew K. Boyd
Andrew K. Boyd, R.P.F.

SCALE:	1:95	4 4 3 E
DATE:	2026-02-05	
DRAWN BY:	SS	
SHEET NO.:	1	
DRAWING NO.:		

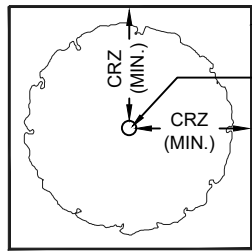

TREE PROTECTION FENCING
TREE TRUNK

PLAN VIEW

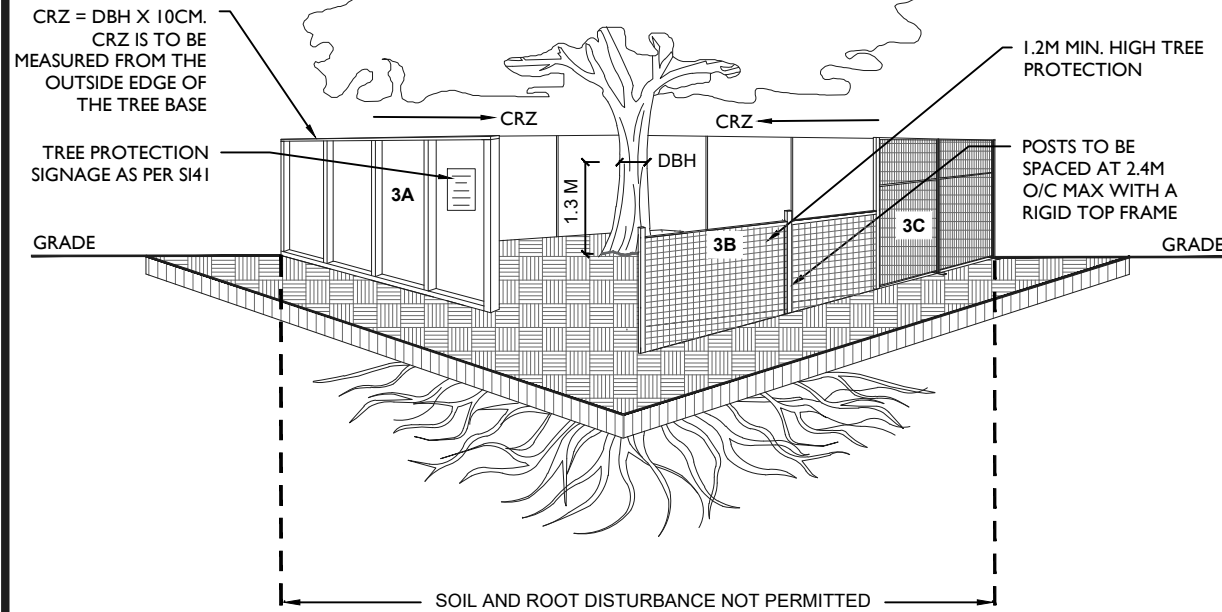

TREE PROTECTION REQUIREMENTS:

1. TREE PROTECTION FENCING MUST BE INSTALLED PER THE TREE CONSERVATION REPORT (TCR) OR THE TREE INFORMATION REPORT (TIR), WHICH EVER APPLIES, AND MUST BE DETERMINED BY AN ARBORIST AND APPROVED BY CITY FORESTRY STAFF PRIOR TO THE COMMENCEMENT OF THE WORK AND REMAIN IN PLACE UNTIL THE WORK IS COMPLETE.
 2. FOR WORK WITHIN THE TREE PROTECTION ZONE (TPZ):
 - DO NOT PLACE OR STORE ANY MATERIAL, FILL OR EQUIPMENT (INCLUDING OUTHOUSES)
 - DO NOT ATTACH ANY SIGNS, NOTICES OR POSTERS TO ANY TREE.
 - DO NOT RAISE OR LOWER THE EXISTING GRADE (SCRAPING OF THE TOP LAYER OF SOIL FOR FINAL GRADING MUST BE AVOIDED WITHIN THE CRZ, THIS INCLUDES FINAL LANDSCAPE/ REINSTATEMENT GRADING).
 - ENSURE THAT EXHAUST FUMES FROM ALL EQUIPMENT ARE DIRECTED AWAY FROM THE TREE CANOPY
 - DO NOT EXTEND/REINSTATE HARD SURFACE WITHIN THE CRZ
 - DO NOT DISPOSE OF WASTE OR VOLATILE MATERIALS, SUCH AS MINERAL SPIRITS, OIL OR PAINT THINNER
 - DO NOT OPERATE, PARK, REPAIR, OR REFUEL VEHICLES OR EQUIPMENT.
 - DO NOT DAMAGE THE ROOT SYSTEM, TRUNK OR BRANCHES OF ANY TREE
 - EXCAVATION SHALL BE CARRIED OUT BY TUNNELING, BORING OR HYDRO VAC
 3. TREE PROTECTION FENCING MUST BE AT LEAST 1.2M IN HEIGHT AND BE CONSTRUCTED OF RIGID OR FRAMED MATERIALS SUCH AS:
 - A. PLYWOOD HOARDING
 - B. SNOW FENCE
 - C. MODULAR STEEL PANELS
- INSTALLATION OF ALL FENCING TYPES, A, B OR C, MUST MINIMIZE DAMAGE TO EXISTING ROOTS.
4. ANY DEVIATION TO THE APPROVED TREE PROTECTION FENCING LOCATION MUST BE SUPERVISED BY AN ARBORIST AND APPROVED BY CITY FORESTRY STAFF. MODIFICATIONS MAY INCLUDE THE INSTALLATION OF PLYWOOD, WOOD CHIPS, OR STEEL PLATING OVER THE ROOTS, OR PERFORMING PROPER ROOT PRUNING AND CARE WHERE ROOTS ARE ENCOUNTERED.
 5. IF TREES ARE BEING AFFECTED BY CONSTRUCTION, A WATER AND FERTILIZING PROGRAM MAY BE REQUIRED.
 6. THE CITY OF OTTAWA'S TREE PROTECTION BY-LAW (NO. 2020-340) AND STANDARD F-8011 APPLY



Tree Protection

SCALE: NTS

DATE: JANUARY 2026

DRAWING NO.: F7

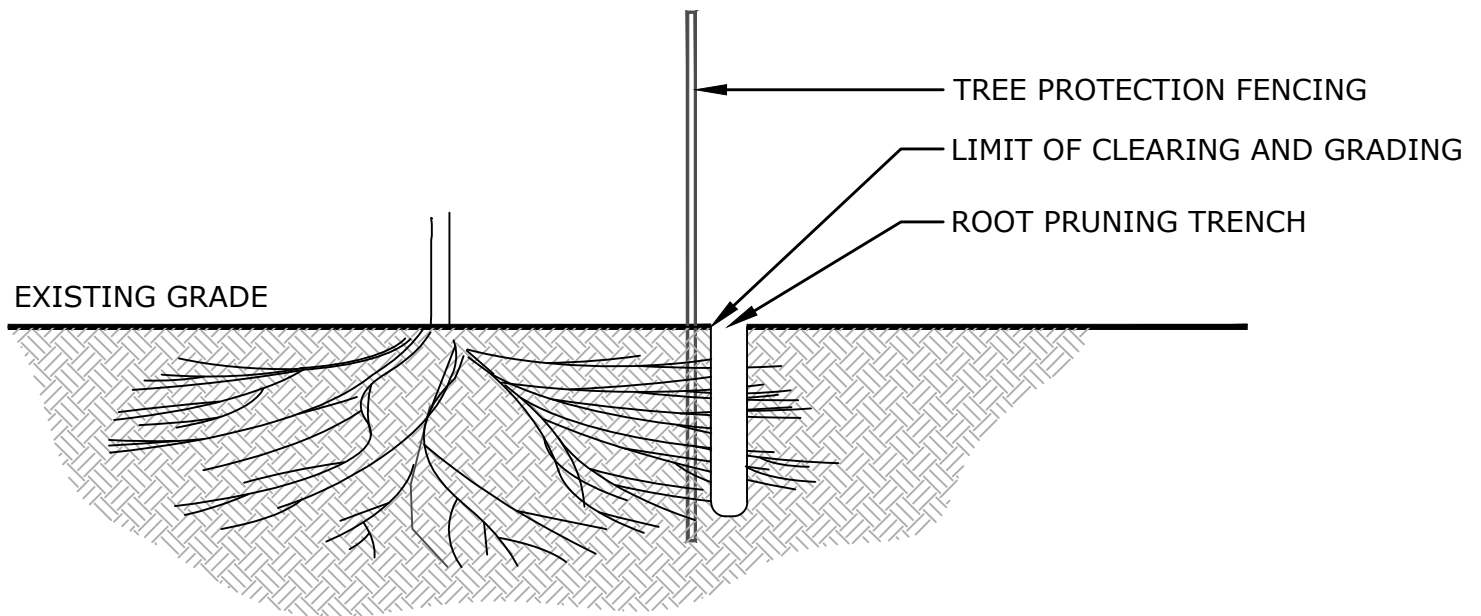

NOTES:

1. PROPER ROOT PRUNING TECHNIQUES REQUIRED WHEN TREE ROOTS ARE ENCOUNTERED DURING EXCAVATION.
2. EXCAVATION (ROOT PRUNING TRENCH) SHALL BE CARRIED OUT BY TUNNELING, BORING OR HYDRO VAC.
3. ROOTS ARE TO BE CLEANLY CUT AND THE AREA AROUND THE ROOTS SHALL BE BACKFILLED WITH SUITABLE MATERIAL, AS DETAILED IN THE CONTRACT DRAWINGS.
4. TREES SHALL BE PRUNED TO RESTORE TREE APPEARANCE AND/OR RESTORE THE BALANCE BETWEEN TOP GROWTH AND ROOTS.
5. LEADERS SHALL NOT BE PRUNED.



Picture 1. Tree #1, shared Norway maple tree 443 Echo Drive



Picture 2. Tree #2, shared Norway maple tree 443 Echo Drive



Picture 3. Tree #3, shared Manitoba maple tree 443 Echo Drive



Picture 4. Tree #4, neighbouring Austrian pine at 443 Echo Drive



Picture 5. Trees #5, 6 and 7 (left to right), black walnut and Norway maple trees at 443 Echo Drive



Picture 6. Tree #8, neighboring hackberry at 443 Echo Drive

LIMITATIONS OF TREE ASSESSMENTS & LIABILITY

GENERAL

It is the policy of *IFS Associates Inc.* to attach the following clause regarding limitations. We do this to ensure that our clients are clearly aware of what is technically and professionally realistic in assessing trees for retention.

This report was carried out by *IFS Associates Inc.* at the request of the client. The information, interpretation and analysis expressed in this report are for the sole benefit and exclusive use of the client. Possession of this report or a copy thereof does not imply right of publication or use for any purpose by any other than the client to whom it is addressed. Unless otherwise required by law, neither all or any part of the contents of this report, nor copy thereof, shall be conveyed by anyone, including the client, to the public through public relations, news or other media, without the prior expressly written consent of the author, and especially as to value conclusions, identity of the author, or any reference to any professional society or institute or to any initialed designation conferred upon the author as stated in his qualifications.

This report and any values expressed herein represent the opinion of the author; his fee is in no way contingent upon the reporting of a specified value, a stipulated result, nor upon any finding to be reported. Details obtained from photographs, sketches, *etc.*, are intended as visual aids and are not to scale. They should not be construed as engineering reports or surveys. Although every effort has been made to ensure that this assessment is reasonably accurate, the tree(s) should be reassessed at least annually. The assessment presented in this report is valid at the time of the inspection only. The loss or alteration of any part of this report invalidates the entire report.

LIMITATIONS

The information contained in this report covers only the tree(s) in question and no others. It reflects the condition of the assessed tree(s) at the time of inspection and was limited to a visual examination of the accessible portions only. *IFS Associates Inc.* has prepared this report in a manner consistent with that level of care and skill ordinarily exercised by members of the forestry and arboricultural professions, subject to the time limits and physical constraints applicable to this report. The assessment of the tree(s) presented in this report has been made using accepted arboricultural techniques. These include a visual examination of the above-ground portions of each tree for structural defects, scars, cracks, cavities, external indications of decay such as fungal fruiting bodies, evidence of insect infestations, discoloured foliage, the condition of any visible root structures, the degree and direction of lean (if any), the general condition of the tree(s) and the surrounding site, and the proximity of people and property. Except where specifically noted in the report, the tree(s) examined were not dissected, cored, probed or climbed to gain further evidence of their structural condition. Also, unless otherwise noted, no detailed root collar examinations involving excavation were undertaken.

While reasonable efforts have been made to ensure that the tree(s) proposed for retention are healthy, no warranty or guarantee, expressed or implied, are offered that these trees, or any parts of them, will remain standing. This includes other trees on or off the property not examined as part of this assignment. It is both professionally and practically impossible to predict with absolute certainty the behaviour of any single tree or groups of trees or their component parts in all circumstances, especially when within construction zones. Inevitably, a standing tree will always pose some risk. Most trees have the potential for failure in the event of root loss due to excavation and other construction-related impacts. This risk can only be eliminated through full tree removal.



Notwithstanding the recommendations and conclusions made in this report, it must be realized that trees are living organisms, and their health and vigour constantly change over time. They are not immune to changes in site conditions, or seasonal variations in the weather. It is a condition of this report that *IFS Associates Inc.* be notified of any changes in tree condition and be provided an opportunity to review or revise the recommendations within this report. Recognition of changes to a tree's condition requires expertise and extensive experience. It is recommended that *IFS Associates Inc.* be employed to re-inspect the tree(s) with sufficient frequency to detect if conditions have changed significantly.

ASSUMPTIONS

Statements made to *IFS Associates Inc.* in regards to the condition, history and location of the tree(s) are assumed to be correct. Unless indicated otherwise, all trees under investigation in this report are assumed to be on the client's property. A recent survey prepared by a Licensed Ontario Land Surveyor showing all relevant trees, both on and adjacent to the subject property, will be provided prior to the start of field work. The final version of the grading plan for the project will be provided prior to completion of the report. Any further changes to this plan invalidate the report on which it is based. *IFS Associates Inc.* must be provided the opportunity to revise the report in relation to any significant changes to the grading plan. The procurement of said survey and grading plan, and the costs associated with them both, are the responsibility of the client, not *IFS Associates Inc.*

LIABILITY

Without limiting the foregoing, no liability is assumed by *IFS Associates Inc.* for: 1) any legal description provided with respect to the property; 2) issues of title and/or ownership with respect to the property; 3) the accuracy of the property line locations or boundaries with respect to the property; 4) the accuracy of any other information provided by the client or third parties; 5) any consequential loss, injury or damages suffered by the client or any third parties, including but not limited to replacement costs, loss of use, earnings and business interruption; and, 6) the unauthorized distribution of the report.

INDEMNIFICATION

An applicant for a permit or other approval based on this report shall agree to indemnify and save harmless *IFS Associates Inc.* from any and all claims, demands, causes of action, losses, costs or damages that affected private landowners and/or the City of Ottawa may suffer, incur or be liable for resulting from the issuance of a permit or approval based on this report or from the performance or non-performance of the applicant, whether with or without negligence on the part of the applicant, or the applicant's employees, directors, contractors and agents.

Further, under no circumstances may any claims be initiated or commenced by the applicant against *IFS Associates Inc.* or any of its directors, officers, employees, contractors, agents or assessors, in contract or in tort, more than 12 months after the date of this report.

ONGOING SERVICES

IFS Associates Inc. accepts no responsibility for the implementation of any or all parts of the report, unless specifically requested to supervise the implementation or examine the results of activities recommended herein. In the event that examination or supervision is requested, that request shall be made in writing and the details, including fees, agreed to in advance.